

WR 325 BF Gas Fired Multipoint Water Heater

INSTALLATION AND SERVICING INSTRUCTIONS

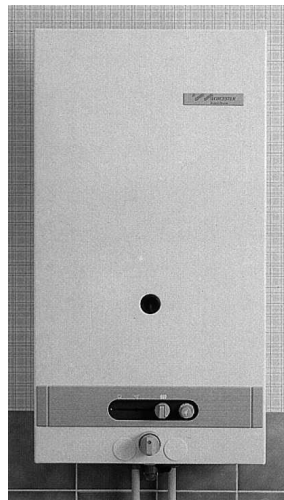

GC NUMBER 52 311 01

For your safety – if you smell gas:

1. Turn off the appliance
2. Open all windows and doors
3. Do not operate any electrical switches
4. Extinguish all naked flames
5. Contact the local Gas Region immediately

This appliance conforms to European Standard EN 26.

It is the law that all gas appliances are installed by competent persons.

The following instructions should be read carefully as the manufacturer cannot be held responsible for any damage to property, persons or animals caused by incorrect installation or operation of the appliance.

It is recommended that the appliance be serviced annually by a competent person or the local Gas Region.

The Users Instructions should be handed to the user and the function and operation of the appliance explained.

Contents

1. Installation Regulations.....	Page 2
2. General Information	Page 2
3. Technical Data	Page 5
4. Siting the Appliance	Page 5
3. Siting the Flue Terminal	Page 5
6. Air Supply	Page 6

7. Gas Supply	Page 6
8. Installation	Page 6
9. Commissioning	Page 7
10. Inspection and Servicing	Page 8
11. Replacement of Parts	Page 9
12. Fault Finding	Page 10
13. Short Parts List	Page 10

1. Installation Regulations

1.1 Gas Safety (Installation and Use) Regulations 1984:- All gas appliances must be installed by a competent person in accordance with the above regulations. Failure to install appliances correctly could lead to prosecution.

1.2 The manufacturer's notes must not be taken, in any way, as overriding statutory obligations.

1.3 The compliance with a British Standard does not, of itself, confer immunity from legal obligations. In particular the installation of this appliance must be in accordance with the relevant requirements of the Gas Safety (Installation and Use) Regulations 1984 (as amended), local Building Regulations, Building Standards (Scotland) (Consolidation), byelaws of the local Water Company and Health and Safety Document No. 635 (Electricity at Work Regulations 1989). It should be in accordance with the relevant recommendations of the following British Standards.

BS 6798:1987 Specification for Installation of gas fired hot water boilers of rated input not exceeding 60 kW.

BS 5546:1990 Installation of gas hot water supplies for domestic purposes.

BS 5440:1:1990 Flues and ventilation for gas appliances of rated input not exceeding 60 kW: Flues.

BS 5440:2:1989 Flues and ventilation for gas appliances of rated input not exceeding 60 kW: Air Supply.

BS 6891:1988 Installation of low pressure gas pipework installations up to 28 mm (R1).

1.4 To ensure that the installation will perform to the highest standards, the system and components should conform to any other relevant British Standards in addition to those mentioned in the instructions.

2. General Information

2.1 This appliance is available for use with natural gas. When installing the appliance for use with natural gas, please check 10 digit number on carton to ensure that the correct appliance has been specified. The 10 digit number for a natural gas appliance is 7 702 340 006.

2.2 This appliance is available for use with LPG. When installing the appliance for use with LPG, please check 10 digit number on carton to ensure that the correct appliance has been specified.

The 10 digit number for an LPG appliance is 7 702 440 007.

2.3 This appliance is not suitable for external installation.

2.4 The appliance is set to provide a maximum output of 21.4 kW and a minimum output of 7 kW.

2.5 The appliance has a permanent pilot.

2.6 PRINCIPLE APPLIANCE COMPONENTS

A low thermal capacity Gas to Water heat exchanger.

A stainless steel main gas burner.

A gas section.

A water section.

A thermoelectric safety valve.

2.7 PACKING

The appliance and flue components are packed in separate cartons.

2.8 GENERAL INSTALLATION

If the appliance is to be fitted into a compartment, the compartment must conform to the requirements of BS 6798:1987: Section 6.

The specified ventilation openings made into a wall or compartment door must not be obstructed.

Do not place anything on top of the appliance.

The clearances specified for servicing must be maintained.

2.9 FLUE

The appliance has a room-sealed balanced flue system to the rear.

The standard flue assembly will accommodate a wall thickness of between 260 mm and 430 mm. The 10 digit code number for the standard flue assembly is 7 709 000 423.

A short flue assembly is available and will accommodate a wall thickness of between 100 mm and 150 mm. The 10 digit code number for the short flue assembly is 7 709 000 425.

An extended flue assembly is available and will accommodate a wall thickness of between 410 mm and 570 mm. The 10 digit code number for the extended flue assembly is 7 709 000 424.

2.10 FACILITY TO FIT A SPOUT AND INTEGRAL TAP KIT

The appliance has the facility for a spout and integral tap kit to be fitted for oversink installation. If this type of installation is required, please order the following components as necessary:

Integral tap kit (incorporating hot and cold taps and handles)	7 709 000 406
Chrome plated swivel spout – 150 mm length	7 709 000 041
Chrome plated swivel spout – 250 mm length	7 709 000 042
Chrome plated swivel spout – 350 mm length	7 709 000 043

Fig. 1. Appliance water flow diagram

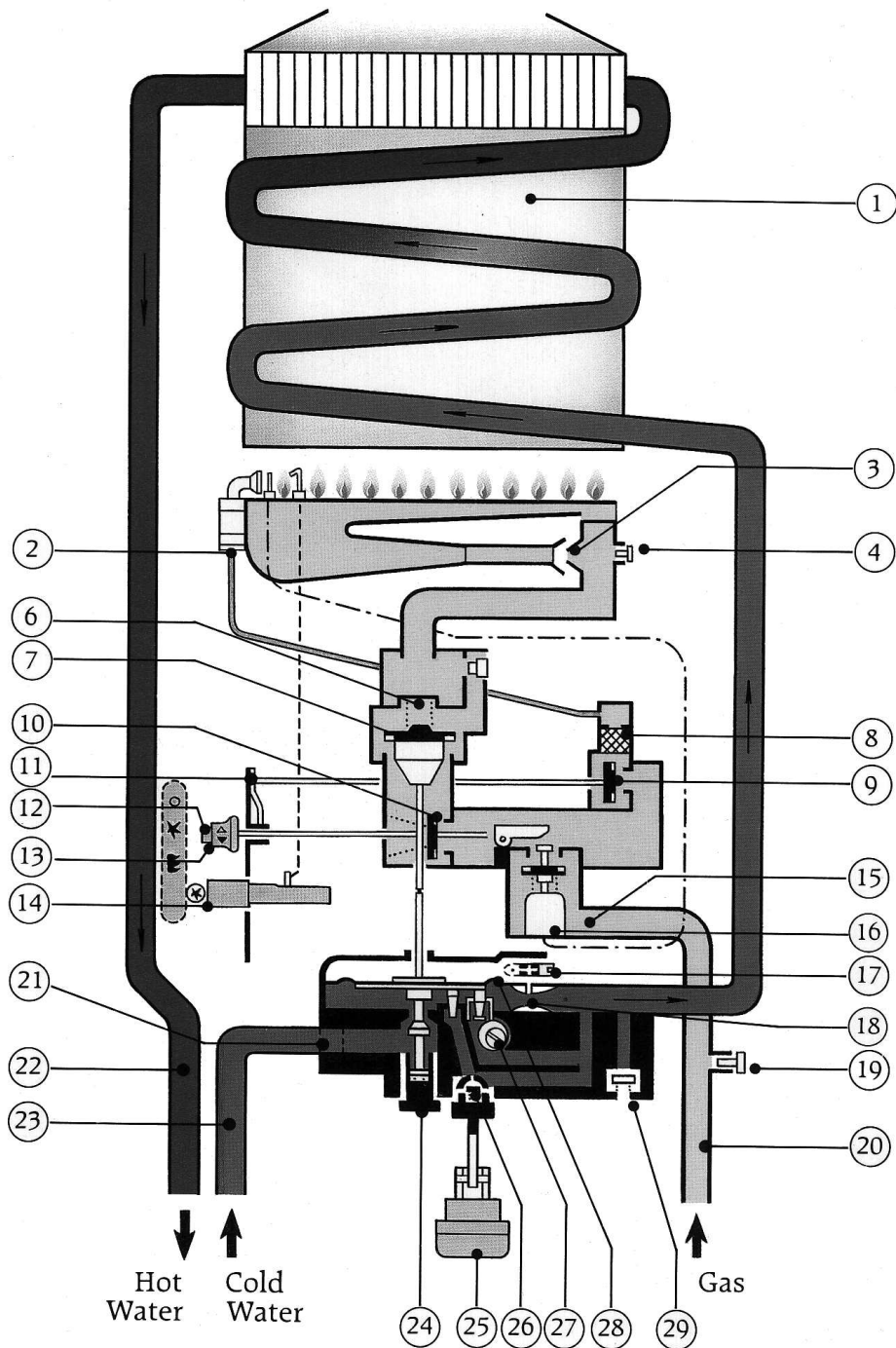

KEY TO COMPONENTS

- | | | |
|------------------------|--------------------------|---|
| 1. Heat exchanger | 11. Pilot gas valve stem | 21. Water strainer |
| 2. Pilot gas pipe | 12. Pilot gas button | 22. Hot water connecting pipe |
| 3. Gas injector nozzle | 13. Gas control slide | 23. Cold water connecting pipe |
| 4. Measuring point | 14. Piezo igniter | 24. Volumetric water governor |
| 6. Valve spring | 15. Gas filter | 25. Water flow selector |
| 7. Large gas valve | 16. Magnetic unit | 26. Relief valve |
| 8. Pilot gas filter | 17. Slow-ignition valve | 27. Correcting screw for minimum water flow |
| 9. Pilot gas valve | 18. Venturi | 28. Diaphragm |
| 10. Main gas valve | 19. Measuring point | 29. Blow-off valve |
| | 20. Gas inlet | |

Fig. 2. Appliance components

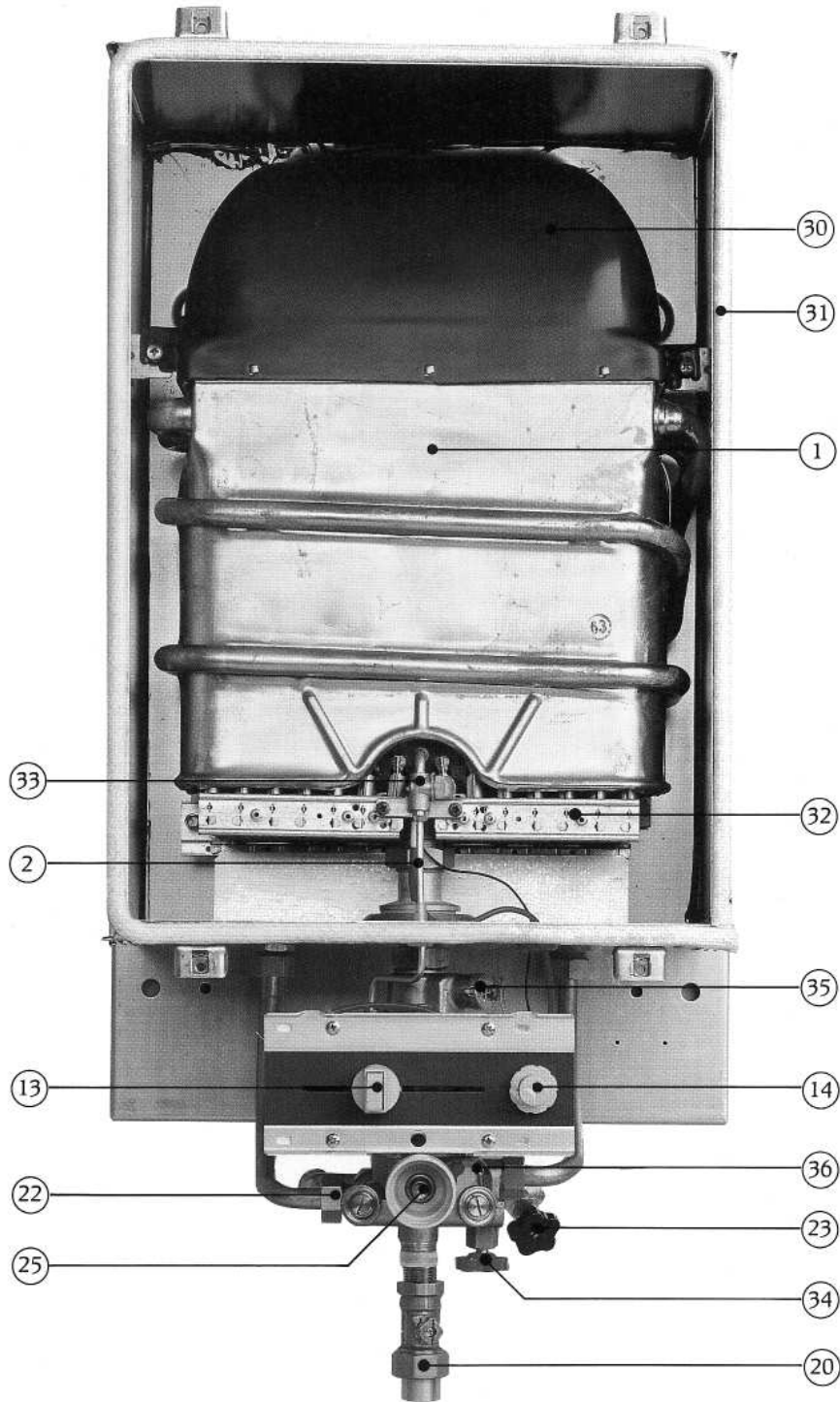

KEY TO COMPONENTS

- | | |
|---|-----------------------------|
| 1. Heat exchanger | 30. Flue hood |
| 2. Pilot gas pipe | 31. Combustion chamber seal |
| 13. Gas control slide | 32. Main gas burner |
| 14. Piezo igniter | 33. Pilot assembly |
| *20. Gas inlet – downward facing | 34. Drain valve |
| 22. Hot water connecting pipe – rear facing, left-hand side | 35. Gas section |
| 23. Cold water connecting pipe – rear facing, right-hand side | 36. Water section |
| 25. Water flow selector | |

* The gas inlet is situated towards the rear of the appliance.
Do not confuse with the spout connection which is part of the brass housing.

3. Technical Data

TABLE 1 – GENERAL

	Natural Gas	LPG
Minimum rated output	7 kW	7 kW
Maximum rated output	21.4 kW	21.4 kW
Rated input	25.5 kW	25.5 kW
Gas rate (maximum)	2.7 m ³ /hr	2.0 m ³ /hr
Number of injectors	14	14
Injector diameter	1.10 mm	0.74 mm
Pilot injector marking	5	49
Burner pressure	17 mbar	27 mbar
Height	755 mm	755 mm
Width	400 mm	400 mm
Depth	220 mm	220 mm
Dry weight	16 kg	16 kg
Gas connection	Rc 1/2	Rc 1/2
Hot/cold water connections	15 mm copper	15 mm copper

TABLE 2 – FLUE DETAILS

Wall hole size – width	224 mm (9 in.)
Wall hole size – height	326 mm (13 in.)
Standard flue – minimum length	260 mm (10.4 in.)
Standard flue – maximum length	430 mm (17.2 in.)
Short flue – minimum length	100 mm (4 in.)
Short flue – maximum length	150 mm (6 in.)
Extended flue – minimum length	410 mm (16.4 in.)
Extended flue – maximum length	570 mm (22.8 in.)

TABLE 3 – PERFORMANCE

Maximum cold water supply inlet pressure	12 bar (180 p.s.i.)
Minimum cold water supply inlet pressure to operate the appliance	0.1 bar (1.5 p.s.i.)
Minimum cold water supply inlet pressure for maximum domestic hot water flow	1.0 bar (15 p.s.i.)
Domestic hot water delivery with temperature control knob fully anticlockwise	4 to 12.3 litres/minute at 25°C temperature rise
Domestic hot water delivery with temperature control knob fully clockwise	2 to 6.1 litres/minute at 50°C temperature rise

4. Siting the Appliance

4.1 The appliance may be installed in any room which has an appropriate outside wall.

4.2 The appliance is not suitable for external installation.

4.3 The appliance does not require any special wall protection.

4.4 The wall must be capable of supporting the weight of the appliance. See Technical Data – Table 1.

4.5 If the appliance is to be fitted in a timber framed building, refer to the British Gas Publication “Guide for gas installations in timber framed housing”.

4.6 The following clearances must be available for installation and for servicing:

Above	50 mm
In front	600 mm
Below	150 mm
Right hand side	10 mm
Left hand side	10 mm

4.7 The appliance can be installed in a cupboard used for airing clothes provided that the requirements of BS 6798 and BS 5440:2 are strictly followed.

4.8 The airing space must be separated from the appliance space by a perforated non-combustible partition. Expanded metal or rigid wire mesh are acceptable provided that the major dimension is less than 13 mm. See BS 6798:1987.

4.9 No combustible surface must be within 75 mm of the casing. See BS 476:4.

4.10 The distance between the inner face of a cupboard door and the cabinet front should not be less than 75 mm.

5. Siting the Flue Terminal

See Fig. 3.

5.1 The flue must be installed as specified in BS 5440:Part 1.

5.2 The terminal must not cause an obstruction nor the discharge cause a nuisance.

5.3 If the terminal is fitted within 850 mm of a plastic or painted gutter or within 450 mm of painted eaves then an aluminium shield at least 750 mm long should be fitted to the underside of the gutter or painted surface.

5.4 If a terminal is fitted less than 2 metres above a surface to which people have access then a guard must be fitted.

5.5 The terminal guard must be evenly spaced about the flue terminal and fixed to the wall using plated screws.

5.6 In certain weather conditions a terminal may steam and siting where this could cause a nuisance should be avoided.

5.7 Take care to ensure that combustion products do not enter ventilated roof voids.

Fig. 3. Siting of the flue terminal.

MINIMUM SITING DIMENSIONS FOR POSITIONING THE BALANCED FLUE TERMINAL

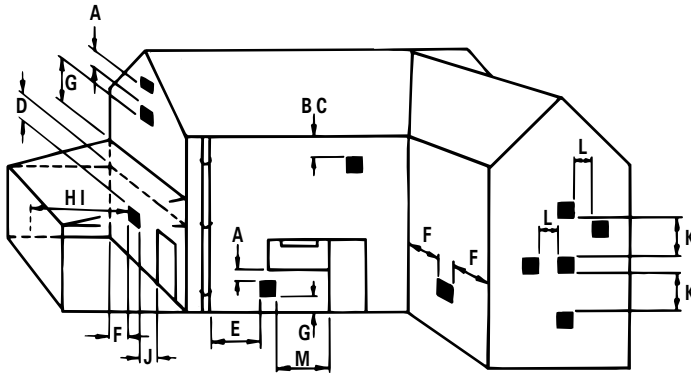

TERMINAL POSITION	MIN. DISTANCE
A- directly below an openable window or other opening e.g. air brick.	1500mm (60 in.)
B- Below gutters, soil pipes or drain pipes.	300 mm (12 in.)
C- Below eaves.	300 mm (12 in.)
D- Below balconies or car port roof.	600 mm (24 in.)
E- From vertical drain pipes and soil pipes.	75 mm (3 in.)
F- From internal or external corners.	600 mm (24 in.)
G- Above ground, roof or balcony level.	300 mm (12 in.)
H- From a surface facing a terminal.	600 mm (24 in.)
I- From a terminal facing a terminal	600 mm (24 in.)
J- From an opening in a car port (e.g. door window) into dwelling.	1200 mm (47 in.)
K- Vertically from a terminal on the same wall.	1500 mm (60 in.)
L- Horizontally from a terminal on the same wall.	300 mm (12 in.)
M- From door, window or air vent (achieve where possible).	300 mm (12 in.)

6. Air Supply

6.1 The appliance does not require a separate vent for combustion air.

6.2 Installations in cupboards or compartments require permanent vents for cooling purposes (one at high level and one at low level) either direct to outside air or to a room. Both vents must pass to the same room or be on the same wall to the outside air.

6.3 There must be sufficient clearance around the appliance to allow proper circulation of ventilation air. The clearances required for installation and servicing will normally be adequate for ventilation.

6.4 The minimum free areas required are given below.

Position of air vents	Air from the room	Air direct from outside
High Level	270 cm ² . (42 in ² .)	135 cm ² . (21 in ²)
Low Level	270 cm ² . (42 in ² .)	135 cm ² . (21 in ² .)

6.5 Refer to BS 6798 and BS 5440:2 for additional information.

7. Gas Supply

The appliance requires 2.7 m³/hr (95.4 ft³/hr) of gas. The gas meter and supply pipes must be capable of supplying this quantity of gas in addition to the demand from any other appliances being served. The following table gives an indication of limiting gas pipe lengths and the allowance to be made for fittings. Refer to BS 6891 for further information.

The meter governor should deliver a dynamic pressure of 20 mbar (8 in w.g.) at the appliance.

The complete installation, including the gas meter, must be tested for soundness and purged. Refer to BS 6891.

A gas service cock must be fitted before each appliance, a gas service cock is supplied with every natural gas appliance (not supplied with LPG model).

Important: If the 2.7m³/hr gas rate to the appliance cannot be reached, the specified hot water conditions will not be achieved. This could result in customer complaints. Always ensure that the gas supply is adequate.

TOTAL LENGTH OF GAS SUPPLY PIPE (metres)			Pipe Diameter (mm)
3	6	9	
Gas Discharge Rate (m ³ /h)			
2.9	–	–	15
8.7	5.8	4.6	22
18.0	12.0	9.4	28

Note: Each fitting used in the gas line from the meter is equivalent to a length of straight pipe which must be added to the straight pipe length to give the total length.

i.e. Elbow = 0.5 metres, Tee = 0.5 metres, 90° bend = 0.3 metres.

8. Installation

The installation must be carried out by competent persons.

On delivery, check to make sure that the packaging has not been damaged. If there is evidence of damage, contact your supplier immediately.

Check the 10 digit code number on the appliance carton to ensure that the correct appliance for the gas supply has been supplied.

The code number for a natural gas appliance is 7 702 340 006.

The code number for an LPG appliance is 7 702 440 007.

Before commencing work, check that the correct flue kit has been supplied. There are three different telescopic flue kits available for various wall thicknesses.

(See Technical Data – Table 2)

8.1 FLUE KIT INSTALLATION

Refer to flue kit installation instructions which are packed inside the flue kit carton.

8.2 APPLIANCE INSTALLATION

(a) Unpack the appliance and take care to remove the installation kit which is packed on top of the polystyrene packing.

The installation kit consists of the following:

One gas service cock (not supplied with LPG model)

One cold water isolating cock complete with fibre washer

One hot water outlet complete with fibre washer

Two 15 mm x 1/2 in. BSP female copper compression fittings

(b) Lay the appliance on its back and pull off the Temperature Control Knob.

(c) Unscrew the plastic Temperature Control Knob housing.

(d) Remove the four casing screw covers. Take out the four casing fixing screws and lift the casing clear.

(e) Remove the collector hood from the appliance by slackening the two fixing screws and lifting the hood clear.

(f) Lift the appliance on to the two mounting studs which are part of the flue kit assembly and fix in position using the two slotted nuts supplied.

If required, there are fixing holes situated on the appliance back plate. Mark the fixing hole positions on the wall. Remove the appliance. Drill and plug the wall and then re-fit the appliance.

(g) Push the flue gas connecting duct into the flue duct stub in the balanced flue assembly making sure it is fully home and resting against the stop protruding from the base of the stub duct. Ensure flue gas connecting duct has been cut to the correct size. See the Flue Kit Installation Instructions.

(h) Re-fit the collector hood making sure that the flue duct spigot on the collector hood enters the flue duct connector. Tighten the two collector hood fixing screws. Connect the gas supply pipe to the appliance via a gas service cock.

Note: The whole of the gas installation should be inspected and tested for soundness and purged in accordance with the recommendations of BS 6891.

(i) Fit the two chrome water fittings supplied using fibre washers. The fitting which includes the stop valve should be fitted onto the rear right hand connection (viewed from the front) and the other fitting onto the rear left hand connection (viewed from the front).

(j) Fit the two copper tails supplied to the chrome water fittings using a jointing compound suitable for use with potable water.

(k) Connect the appliance to the incoming cold water supply via the fitting which includes the stop valve.

(l) Connect the appliance to the domestic hot water remote draw off points via the other fitting.

(m) At the bottom centre of the water section assembly there is an additional 1/2 in. male threaded joint which is the connecting thread for when a spout is connected for an oversink installation. See General Information paragraph 2.10.

This outlet will not pass water until such time as an integral tap kit is installed on to the appliance and therefore, in a normal remote draw off installation, the 1/2 in. male threaded joint should be left unconnected and unplugged.

(n) Turn on the water supply to the appliance. Open the stop valve on the inlet fitting to the appliance and then open the highest hot water tap in the installation.

Allow water to pass in order to vent the system of air. Close the tap.

9. Commissioning

Before commissioning the appliance, the whole gas installation must be purged and tested for gas soundness in accordance with the current edition of BS 6891.

Important: Open all doors and windows. Extinguish naked lights and do not smoke while purging the gas line.

(a) Ensure that the gas service cock in the gas inlet pipe is turned off.

(b) Loosen screw A and connect a pressure gauge to the test point. See Fig. 4.

(c) Turn on the gas service cock.

(d) Move the gas control slide to the ignition position. See Fig. 5. Observe the pilot burner through the observation window. Press in the centre button of the control slide and hold depressed while pushing in the Piezo igniter button two or three times. The pilot

Fig. 4. Inlet pressure test point

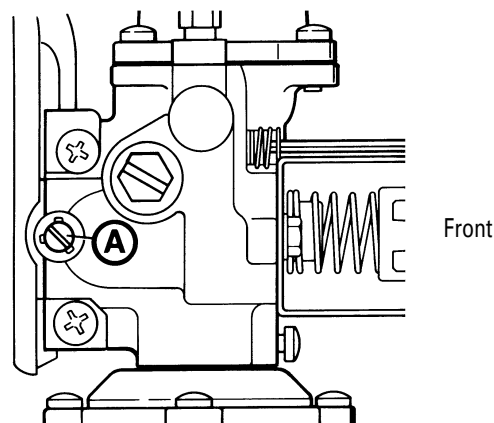

should light. Wait 20 seconds and then release the centre button of the control slide.

The pilot should remain alight. If the pilot is not established, repeat the operations until a flame is established.

Note: On initial light up, or after prolonged shut-down, the establishment of the pilot may take several attempts due to the presence of air in the gas supply pipe.

The pilot flame should envelope approximately 5 mm of the thermocouple head.

(e) Move the control slide fully to the right. See Fig. 6. Fully open any hot water tap. The main burner should light.

(f) Check the dynamic inlet gas pressure. The pressure for natural gas should be 20 mbar and the pressure for LPG should be 37 mbar.

Fig. 5. Gas control slide – ignition position

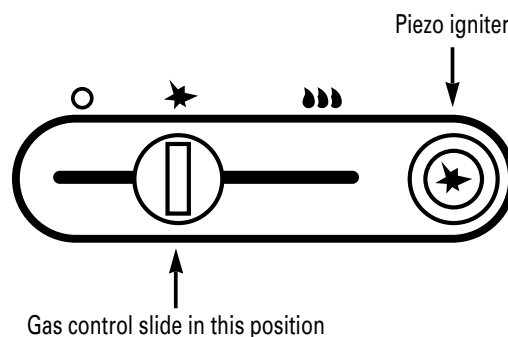

Fig. 6. Gas control slide – operating position

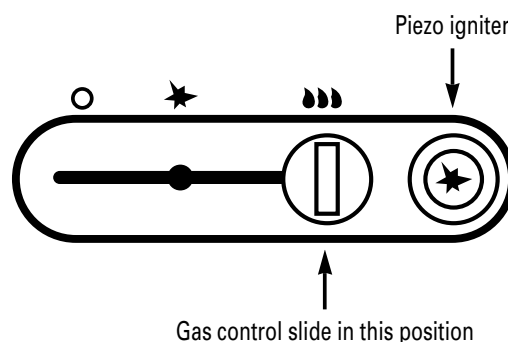
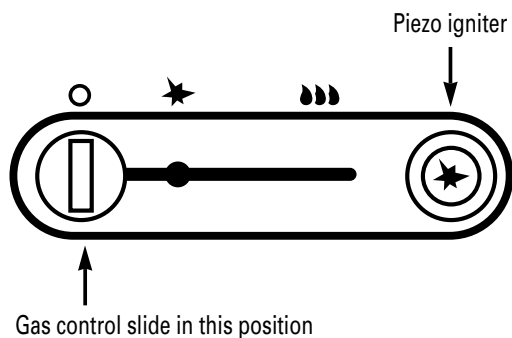

Fig. 7. Gas control slide – shut down position



If the pressure is not correct then check the gas supply to the appliance.

If the pressure is correct, turn off the hot water tap and move the control slide to the off position. See Fig. 7.

Turn off the gas service cock. Remove the pressure gauge and tighten screw A. See Fig. 4.

(g) Loosen screw D and connect a pressure gauge to the test point. See Fig. 8.

Re-light the appliance as described in paragraph 9 (d and e).

(h) Operate the appliance for at least 2 minutes then check that the burner pressure is as stated in Technical Data – Table 1.

(i) Turn off the hot water tap. Close the gas service cock. Remove the pressure gauge and tighten screw D.

(j) Re-fit the appliance casing using the four fixing screws. Fit the plastic Temperature Control Knob housing. Fit the Temperature Control Knob. Fit the four casing screw covers.

(k) On completion of the commissioning and testing of the system, the installer should hand over the appliance to the user with reference to the following:

1. Give the Users Operating Instructions leaflet to the user.
2. Explain and demonstrate the lighting and shutdown procedures.
3. Advise the user of the precautions necessary to prevent damage to the system and to the building in the event of the system remaining inoperative during frost conditions.
4. Stress the importance of an annual service by a competent heating engineer.

Fig. 8. Gas pressure test point

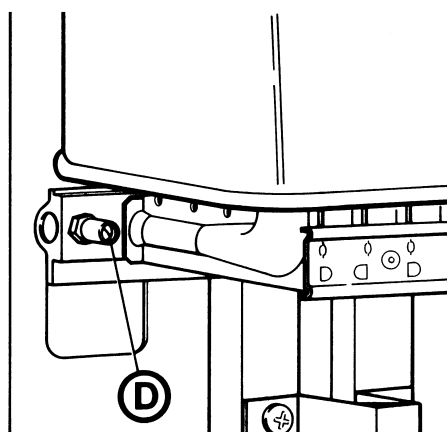

10. Inspection and Servicing

To ensure continued efficient operation of the appliance, it is recommended that it is checked and serviced as necessary at regular intervals.

The frequency of servicing will depend upon the particular installation conditions and usage but in general once a year should be adequate.

It is the law that any service work must be carried out by a competent person such as British Gas or other Corgi registered personnel.

Before commencing any service operation turn off the gas supply at the main gas service cock.

ACCESS FOR SERVICING

Remove the front casing by removing the four plastic screw covers and then remove the four fixing screws.

Pull off the Temperature Control Knob.

Unscrew Temperature Control Knob housing.

Lift the casing clear.

10.1 Heat exchanger

Remove the collector hood assembly by slackening the two retaining screws and pulling the hood out of the flue connector duct. If the connector duct comes away with the collector hood separate them and push the connector duct back into the stub in the balanced flue assembly making sure that it is fully home and resting against the two stops protruding from the sides of the stub duct.

Inspect and clean the heat exchanger flueways if necessary.

To remove the heat exchanger, isolate the appliance from the incoming cold supply and drain down the appliance via the drain cock fitted.

Disconnect the heat exchanger flow and return pipes at the water section and the base of the combustion chamber.

Remove the locknuts from the heat exchanger stubs and lift the heat exchanger clear.

In hard water areas it may be necessary to descale the heat exchanger body. Either a proprietary brand of descaler or a solution of 10 parts of water to 1 part of hydrochloric acid should be used. Fill the heat exchanger with this solution and leave until the solution stops bubbling. Drain and thoroughly wash out the exchanger with clean water.

Warning: Acid/water solutions must be used with extreme caution. Take care not to splash on to the skin or into the eyes. Wash any affected areas with large amounts of cold water and seek medical advice.

10.2 Pilot assembly

Inspect the pilot injector and clean if necessary.

Check the pilot burner and electrode are clean and undamaged. Clean or replace if necessary.

Pull off the pilot filter and clean.

10.3 Main burner

Disconnect the pilot gas pipe and thermocouple at the gas valve and pull off the red cable from the Piezo unit.

Disconnect the pilot gas pipe from the pilot burner and remove from the appliance complete with seal. Take care not to lose the pilot injector.

Remove the two screws retaining the pilot bracket and lift the complete assembly clear.

Undo the union connection below the burner. Lift the burner clear and remove.

Inspect and clean the injectors if necessary.

Inspect and clean the main burner bars if necessary.

10.4 Slow ignition valve

Screw out the slow ignition valve (which is located on the right hand side of the valve above the water flow pipe into the heat exchanger. Item 17, Fig. 1.

The ball within the valve should move freely. Check by shaking.

Check the O-ring and replace if necessary.

Re-assemble in reverse order.

10.5 Re-assembling the appliance

Re-assemble the appliance in reverse order ensuring the following:

1. The collector hood outlet duct correctly enters the flue connecting duct.
2. The washer in the main gas line union connection is correctly located.

3. The seals around the igniter cable/thermocouple and pilot gas pipe are correctly seated in the combustion chamber base and the pilot injector has been fitted.

Turn on the gas supply at the main gas service cock and check for gas soundness in accordance with the current edition of BS 6891 while the appliance is running.

Re-commission the appliance as detailed in Section 9.

11. Replacement of Parts

It is the law that any service work must be carried out by a competent person such as British Gas or other Corgi registered personnel.

Before commencing any service operation turn off the gas supply at the main gas service cock.

11.1 Pilot burner/injector

Disconnect the pilot gas pipe and thermocouple at the gas valve and pull off the red cable from the Piezo unit.

Disconnect the pilot gas pipe from the pilot burner and remove from the appliance complete with seal. Take care not to lose the pilot injector. Replace injector if necessary.

Remove the two screws retaining the pilot bracket and lift the complete assembly clear complete with the red seal.

Pull off the pilot filter. Undo the screw fixing the spark electrode /thermocouple retaining bar and lift these clear.

Replace the pilot burner/bracket and re-assemble in reverse order.

11.2 Spark electrode/thermocouple

Follow the instructions in Section 11.1 and replace the faulty component.

11.3 Main burner

Disconnect the pilot gas pipe and thermocouple at the gas valve and pull off the red cable from the Piezo unit.

Disconnect the pilot gas pipe from the pilot burner and remove from the appliance complete with seal. Take care not to lose the pilot injector.

Remove the two screws retaining the pilot bracket and lift the complete assembly clear.

Undo the union connection below the burner. Lift the burner clear of the union and push the front of the burner up into the combustion chamber so that it is standing vertically against the rear. Pull the rear of the burner forward so that the burner is now upside down and work out between the combustion chamber skirt and gas pipe.

Replace the burner and re-assemble in reverse order taking care that the seals around the igniter cable/thermocouple and pilot gas pipe are correctly seated in the combustion chamber base and the pilot injector has been fitted.

11.4 Heat exchanger

Remove the collector hood assembly by slackening the two retaining screws and pulling the hood out of the flue connector

duct. If the flue connector duct comes away with the collector hood, separate them and push the connector duct back into the stub in the balanced flue assembly making sure that it is fully home and resting against the two stops protruding from the sides of the stub duct.

Isolate the appliance from the incoming cold water supply and drain down the appliance via the fitted drain cock.

Disconnect the heat exchanger inlet and outlet pipes at the water section and at the base of the combustion chamber.

Remove the locknuts from the heat exchanger stubs and lift the heat exchanger clear.

Replace the heat exchanger and re-assemble in reverse order.

11.5 Piezo unit

Pull off the two wires from the rear of the unit, unscrew the plastic retaining nut on the control panel and push out the Piezo unit.

Replace and re-assemble in reverse order.

11.6 Water section

Isolate the appliance from the incoming cold water supply and drain down the appliance via the fitted drain cock.

Disconnect the four union connections.

Release the two screws between the water section and gas section and pull the water section clear.

The diaphragm within the valve can be replaced by removing the three fixing screws holding the valve body together.

The water filter fitted into the incoming cold water tapping can be cleaned or replaced by pulling it out.

Re-assemble in reverse order.

11.7 Gas valve

Remove the water section as described in Section 11.6.

Disconnect the pilot gas pipe and thermocouple from the gas valve.

Pull off the two cables from the rear of the Piezo unit.

Release the main gas pipe union connection below the combustion chamber and lift the valve clear complete with the control panel.

Remove the Piezo unit as described in Section 11.5.

Remove the control facia by taking out the four fixing screws and lifting clear complete with slider knob.

Prise out the slider bar and remove the two screws retaining the control frame and lift clear.

Replace the gas valve and re-assemble in reverse order.

12. Fault Finding

Problem	Cause	Solution
Incorrect water temperature	Incorrect gas rate	Check the gas supply to appliance gas service cock Open the gas service cock Check the burner pressure Check the inlet pressure
	Water section sticking or faulty	Clean or replace
Incorrect water flow rate	Incoming supply valve closed	Open supply valve
	Low water pressure	Check the water pressure is above 0.1 bar
	Water section sticking or faulty	Clean or replace
Noise	Scale in heat exchanger	Descale and service
	High gas rate	Check the burner pressure
	Low water flow rate	Check the water flow rate
Pilot flame will not stay alight	No gas supply	Connect gas supply
	Gas service cock closed	Open gas service cock
	Air in gas line	Purge the line
	Pilot injector blocked	Clean/replace the injector
	No spark	Clean or replace the electrode, Piezo unit or cable
Main burner will not light	Gas pressure low	Check the inlet and burner pressure
	Gas service cock partially closed	Open the gas service cock
	Low water rate	Check the water rate
	Water section diaphragm faulty	Replace the diaphragm
	Gas valve faulty	Replace the gas valve
Explosive ignition	Reduced pilot flame	Clean or replace the pilot injector assembly
	Faulty slow ignition valve	Replace the slow ignition valve

13. Short Parts List

	Part	Manufacturer's Reference		
	Pilot Burner	8 718 105 048		
	Pilot Injector	8 708 200 005		
	Thermocouple	8 747 202 039		
	Spark Electrode	8 708 107 002		
	Piezo Unit	8 748 108 023		
	Water Section	8 707 002 457		
	Diaphragm	8 700 503 051		
	Slow Ignition Valve	8 708 503 063		
	Gas Valve	8 707 011 028		
	Temperature Control Knob	8 702 000 111		
	Control Facia Plate	8 701 000 104		

Additional Information

1. CE Certification



MODEL	WR325-1AD...	WR325-1AV...
CE NUMBER	CE 0085 AQ 0293	
CATEGORIES	I _{2H}	I ₃₊
TYPE	C ₁₁	

2. Symbols on Data Plate

- P_n - Nominal useful output
- P_{min} - Minimum useful output
- Q_n - Nominal heat input
- Q_{min} - Minimum heat input
- P_w - Maximum service water pressure
- P_{wmin} - Minimum service water pressure

Type: C₁₁ - Natural draught appliances



*Worcester Heat Systems Limited, Cotswold Way, Warndon, Worcester WR4 9SW.
Telephone: (01905) 754624. Fax: (01905) 754619.*

This booklet is accurate at the date of printing but will be superseded and should be disregarded if specifications and/or appearances are changed in the interests of continued improvement.

All goods sold are subject to our official Conditions of Sale, a copy of which may be obtained on application.

PUBLICATION 6 720 603 494, ISSUE 1 –SEPTEMBER 2001