

GREENSTAR CAMRAY UTILITY & UTILITY SYSTEM

**FLOOR STANDING OIL FIRED CONDENSING BOILER
CONVENTIONAL FLUE & ROOM SEALED FLUE**

**FOR FULLY PUMPED OPEN VENT OR SEALED CENTRAL HEATING SYSTEMS AND
DOMESTIC HOT WATER CYLINDERS**

For use with the following Greenstar oil fired appliances:

Greenstar Camray Utility 12/18, 18/25, 25/32

Greenstar Camray Utility System 12/18, 18/25, 25/32

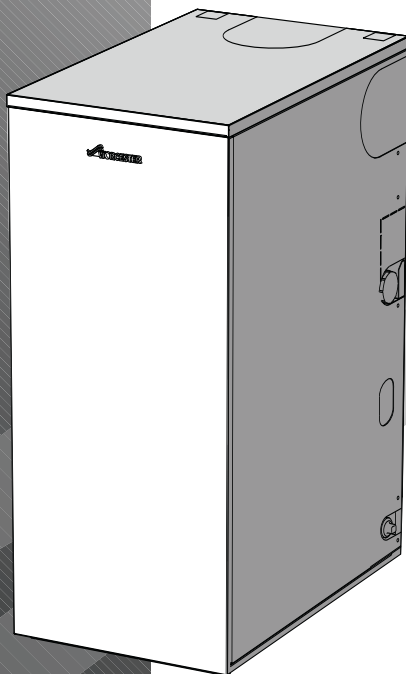

THE APPLIANCE IS FOR USE WITH 28
SECOND KEROSENE ONLY

GB

**WORCESTER**
Bosch Group

**USER INSTRUCTIONS
& CUSTOMER CARE GUIDE**

CONTACT INFORMATION

Worcester, Bosch Group:

Service call centres:

UK TEL: 08457 256206
FAX: 08457 757536

SCOTLAND ONLY FAX: 01506 441687

Other enquiries: TEL: FAX:
MAIN RECEPTION: 01905 754624 754619
TECHNICAL: 08705 266241
SPARES: 01905 752571
LITERATURE: 01905 752556
SALES: 01905 752640
WEBSITE: www.worcester-bosch.co.uk

WATER TREATMENT:

FERNOX 01799 550811

www.fernox.com

SENTINEL 0151 420 9595

www.betzdearborn.com/sentinel

FLUE TERMINAL GUARDS:

WORCESTER, BOSCH GROUP

OIL FIRING TECHNICAL ASSOCIATION:

OFTEC 0845 6585080

www.oftec.org

USER INSTRUCTIONS & CUSTOMER CARE GUIDE

PLEASE READ THESE INSTRUCTIONS CAREFULLY BEFORE OPERATING YOUR APPLIANCE.

THESE INSTRUCTIONS ARE APPLICABLE TO THE WORCESTER, BOSCH GROUP APPLIANCE MODEL(S) STATED ON THE FRONT COVER OF THIS MANUAL ONLY AND MUST NOT BE USED WITH ANY OTHER MAKE OR MODEL OF APPLIANCE.

IF YOU ARE IN ANY DOUBT CONTACT THE WORCESTER, BOSCH GROUP TECHNICAL HELPLINE.

PLEASE KEEP THESE INSTRUCTIONS WITH THE INSTALLATION AND SERVICING INSTRUCTIONS IN A SAFE PLACE OR WITH THE APPLIANCE AFTER INSTALLATION OR SERVICING.

DO NOT INTERFERE WITH ANY SEALED COMPONENTS.

ABBREVIATIONS:

Ø Diameter.
CH Central Heating.
DHW Domestic Hot Water.
TRV Thermostatic Radiator Valve.
IP Ingress Protection.
CF Conventional flue.
RS Room sealed flue.
N/A Not allowed.

SEDBUK Seasonal Efficiency for Domestic Boilers in the United Kingdom.

OFTEC Oil Firing Technical Association for the Petroleum Industry.

CONTENTS

INTRODUCTION

SAFETY PRECAUTIONS	2
EXCELLENCE COMES AS STANDARD	3
GENERAL INFORMATION	4-6

USING YOUR APPLIANCE

CONTROLS	7
OPERATING THE APPLIANCE	
Switching the boiler on/off	8
Setting the heating temperature	8
Controlling central heating	8
Fault conditions	9

ENERGY SAVING

TIPS ON ENERGY SAVING	10-11
-----------------------	-------

MAINTENANCE

MAINTAINING YOUR APPLIANCE	12
FAULT FINDING	13
FAULT OR BREAKDOWN	14

GUARANTEE

YOUR GUARANTEE	15
GUARANTEE REGISTRATION	16

OIL SMELLS, LEAKS OR FUMES FROM THE APPLIANCE:

- ▶ Extinguish any naked flames.
- ▶ Open windows and doors.
- ▶ Switch off the appliance electricity supply.
- ▶ Isolate the fuel supply to the boiler.
- ▶ Contact installer/service engineer.

HEALTH & SAFETY:

The appliance contains no asbestos and no substances have been used in the construction process that contravene the COSHH Regulations (Control of Substances Hazardous to Health Regulations 1988). Where applicable, the CE mark indicates compliance with relative EU Directives.

COMBUSTIBLE AND CORROSIVE MATERIALS:

Do not store or use any combustible materials (paper, thinners, paints etc.) inside or within the vicinity of the appliance.

The combustion air must be kept clear of chemically aggressive substances which can corrode the appliance and invalidate any warranty.

SAFETY PRECAUTIONS

FITTING & MODIFICATIONS:

Fitting the appliance and any controls to the appliance may only be carried out by a competent engineer in accordance with the relevant Installation Regulations.

Flue systems must not be modified in any way other than as described in the fitting instructions.

Any misuse or unauthorised modifications to the appliance, flue or associated components and systems could invalidate the warranty. The manufacturer accepts no liability arising from any such actions, excluding statutory rights.

This appliance is suitable for use with 28 second kerosene only, no other fuel must be used.

SERVICING:

The user must have the system regularly serviced by a competent, qualified OFTEC registered engineer using approved spares, to help maintain the economy, safety and reliability of the appliance.

The appliance should be serviced once each year after installation unless the installation conditions and usage demand more frequent services.

DO NOT OPERATE THE APPLIANCE WHEN:

- ▶ The appliance, flue or system is incorrectly fitted, faulty or damaged.
- ▶ The flue terminal outlet fitted on the outside wall or roof is obstructed or damaged.
- ▶ There are fumes, fuel leaks or fuel smells from the fuel supply, appliance or flue system.
- ▶ The system is empty, frozen or unpressurised (sealed systems).
- ▶ The condensate pipe is blocked or restricted.
- ▶ The appliance clearances are inadequate.
- ▶ The air supply is restricted or vents damaged.

EXCELLENCE COMES AS STANDARD

Thank you for purchasing a Greenstar oil fired condensing boiler from Worcester, Bosch Group. The company prides itself on manufacturing boilers to the strictest quality control standards throughout every stage of production.

Worcester, Bosch Group has led the field in innovative appliance design and performance for more than 40 years. This heritage means all products are of exceptional quality and proven reliability.

The condensing range in particular, is extremely energy efficient, converting more of the fuel consumed into heat offering you economical running costs and value for money. It sits in SEBUK band A, at the top of the energy rated appliances available.

There is also the assurance of our no-nonsense parts and labour guarantee - backed up by an optional servicing and maintenance contract to keep your boiler operating at peak condition and efficiency.

To find out more about Worcester, Bosch Group, use the 'Contact Information' shown on the inside front cover.

Read these instructions carefully to get the best from your appliance.

CENTRAL HEATING SYSTEMS:

During the first few hours of operation of the central heating system, check that all radiators are being heated at an even rate.

If the top of a radiator is at a lower temperature than the bottom then it should be vented by releasing air through the venting screw at the top of the radiator. Ask your installer to show you how this is done. Repeated venting will reduce the quantity of water in the system and this must be replenished for safe and satisfactory operation of the appliance.

When excessive venting or water leaks are found in the system you must contact a service engineer to inspect the installation and rectify any fault.

Only use additives compatible with the appliance and system. Use of incompatible additives can cause damage and will invalidate the appliance guarantee.

Frost protection:

Use a suitable anti-freeze/inhibitor at the correct strength to protect against freezing.

A frost thermostat should be fitted to the system where the system is most exposed and at risk of freezing.

Sealed heating systems:

Where the appliance is fitted to a sealed heating system your installer will inform you of the minimum and maximum pressure which must be indicated on the pressure gauge.

Regularly check the pressure is maintained and contact your installer or maintenance engineer if there is a noticeable, permanent drop in pressure. If the system loses pressure it should be repressurised and the cause of the loss investigated.

GENERAL INFORMATION

CONDENSATE:

This is a high efficiency appliance using condensing technology which will under normal operation produce a regular discharge of condensate to drain and at times, give out a plume of water vapour from the flue terminal.

ROOM THERMOSTAT:

A room thermostat must be fitted to control the central heating. Refer to instructions supplied with the room thermostat for information on siting and setting.

THERMOSTATIC RADIATOR VALVES:

It is recommended that this type of valve is fitted to all but one of the radiators (or at least those in the sleeping accommodation). The remaining radiator, which must be where the room thermostat is located, should be un-controlled and must be left open.

Pressure gauge on the Camray Utility System model.

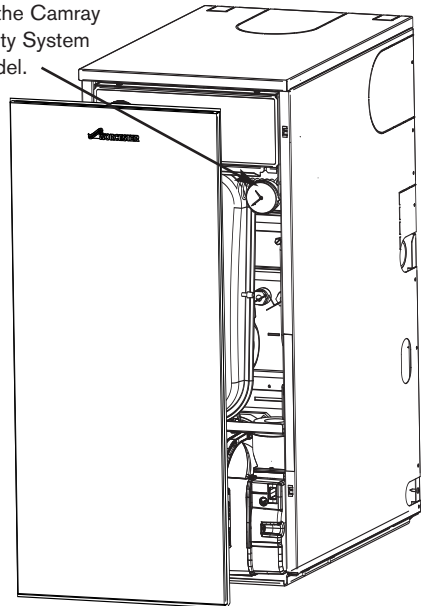

GENERAL INFORMATION

BOILER LOCATION:

This boiler is only suitable for installing internally within a property at a suitable location onto a fixed rigid surface at least the same size as the boiler and capable of supporting the boiler weight.

The boiler is not suitable for external installation unless a suitable enclosure is provided.

Roof space installations must fully conform to BS 5410 part 1 section 4.6.9.

**** The boiler can be installed under a worktop as long as:**

- ▶ The worktop above the boiler is removable for maintenance.
- ▶ There is at least 10mm clearance above the boiler.
- ▶ The front of the boiler is not enclosed.

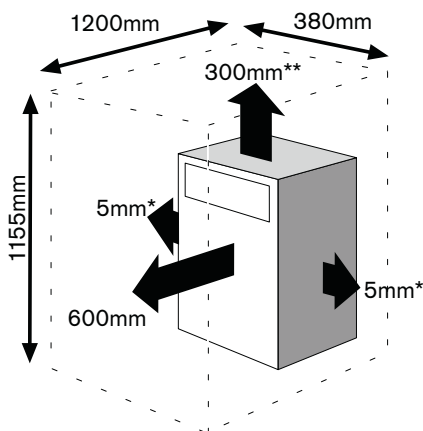

VENTILATION:

Air vents must be functional at all times and the air supply must not be restricted or contaminated.

The appliance clearances must meet the minimum shown opposite for servicing and venting purposes.

** If this clearance is less than 75mm the flue 'knock-out' panel sections must be removed to improve air circulation and cooling.*

Do not place clothes or objects to hinder the air circulation required by the appliance.

Conventional flue appliances require an adequate supply of fresh air which must be delivered to the boiler for combustion purposes through a permanent inlet, such as an air brick, into the area where the boiler is situated.

Conventional flued appliances:

Minimum area of of air inlet for combustion:

Model	Area (cm ²)
12/18	72
18/25	110
25/32	138

GENERAL INFORMATION

If a cupboard or compartment which is to be used for storage or airing is built around the appliance after installation there must be a non-combustible partition around the boiler. Further information can be found in BS 5410 which also describes venting requirements.

Venting compartments:

- ▶ Ventilation must be provided for boilers fitted into compartments as described in BS 5410
- ▶ A minimum of 2 air vents must be fitted, one at low level and another at high level onto the same wall using the same air for circulation.
- ▶ Combustion air must not be taken from a room or internal space containing a bath or shower and must not communicate with a protected area such as a hall, stairway, landing, corridor, lobby, shaft etc.
- ▶ Air vents must allow access for clean free air and must be sited to comply with the flue terminal position requirements.
- ▶ Air ducting runs must not exceed 3m.
- ▶ Low level air vents must be less than 450mm from the floor.
- ▶ A warning label must be added to the vents with a statement to the effect: "Do not block this vent. Do not use for storage".

MINIMUM AIR VENT AREA (cm²) FOR APPLIANCES INSTALLED IN A COMPARTMENT:

¹Internal air to and from a space/room inside the building.

²External air to and from directly outside the building.

Conventional flue:

Model	Internal ¹ ventilation		External ² ventilation	
	High Level	Low Level	High Level	Low Level
12/18	143	215	72	143
18/25	220	330	110	220
25/32	275	413	138	275

Room Sealed flue:

Model	Internal ¹ ventilation		External ² ventilation	
	High Level	Low Level	High Level	Low Level
12/18	143	143	72	72
18/25	220	220	110	110
25/32	275	275	138	138

CONTROLS

UTILITY & UTILITY SYSTEM MODELS:

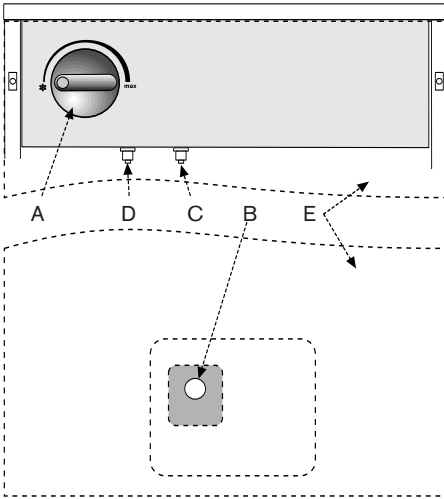

- A Temperature control.
- B Reset button - burner lock-out indicator/reset button (*on the burner control box behind the front panel*).
- C Reset button - boiler overheat thermostat (*behind front panel*).
- D Reset button - flue overheat thermostat (*behind front panel*).
- E Front panel.

OPERATING THE APPLIANCE

TEMPERATURE CONTROL:



SWITCHING THE BOILER ON/OFF:

- ▶ To switch on the boiler; turn ON the water, oil and electricity supply to the boiler.
- ▶ Check the programmer/timer is correct and it is set to ON.
- ▶ Set the room thermostat to the desired setting.
- ▶ Open and set thermostatic radiator valves as required.
- ▶ Turn the boiler water temperature control to the required setting.
- ▶ To switch off the boiler; turn the programmer/timer to OFF for heating and hot water. *If the appliance is left unused and exposed to freezing conditions; shut off all the mains supplies, isolate the boiler and drain the system and boiler.*

SETTING HEATING TEMPERATURE:

- ▶ Turn the control clockwise to increase the radiator temperature.
- ▶ Turn the control anti-clockwise to reduce the radiator temperature.

The minimum and maximum ranges of the heating control positions are approx. 55°C to 81°C.

CONTROLLING CENTRAL HEATING:

- ▶ Set the programmer/timer to the correct time with the required ON/OFF periods.
- ▶ Turn the room thermostat to the temperature required.
- ▶ Set thermostatic radiator valves to the required temperature for each room.

a), c)

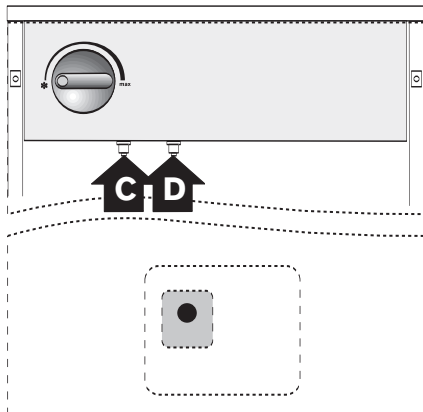

b)

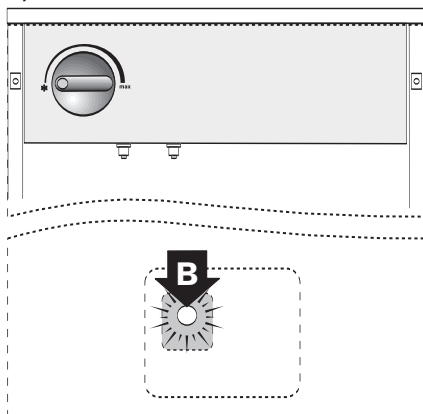

ACCESSING RESET BUTTONS:

PULL BOTTOM OF FRONT PANEL OUT AND LIFT TO REMOVE.

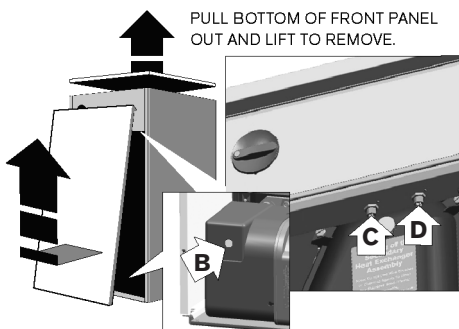

OPERATING THE APPLIANCE

FAULT CONDITIONS:

The burner lockout indicator/reset button can indicate some basic faults:

Normal operation:

a) Lockout indicator OFF:

The burner will cycle on and off under the control of the programmer/timer and the thermostats.

Lockout indicator light:

b) Light ON, boiler not firing:

1. Check oil level in the oil storage tank.
2. Press button (B). Boiler should fire.
3. If no response, wait 2 minutes - press reset button (B) again.
4. If lockout light stays on, do not attempt further resets. Contact your service engineer for advice.

c) Light OFF, boiler not on, no heating/hot water:

1. Ensure there is a power supply to the boiler.
2. Check the programmer is set to ON for heating.
3. Check the setting of the room thermostat, boiler temperature control/tank thermostat.
4. Press reset buttons (C and D).
5. If the boiler stays off contact your service engineer for advice.

TIPS ON ENERGY SAVING

Heating economically:

The boiler is designed to provide a high level of comfort while keeping oil consumption and the resulting environmental effect as low as possible.

The temperature control on the boiler should be set as low as possible while still maintaining a comfortable room temperature.

The temperature of each room can be set individually using the thermostatic radiator valves (except the primary room with the room thermostat).

Roof insulation:

Around 30% of the heat loss from a property is through the roof. Replace any old insulation with new insulation, preferably to a minimum thickness of 200mm.

Window frames:

Single glazed windows, particularly those with steel frames, can lose a great deal of heat.

Consideration should be given to replacement with PVCu or wooden framed double glazed units.

Curtains:

Lined curtains, or heavier full length curtains can provide excellent insulation. However, always ensure that the curtains do not drape over radiators.

Draughts:

Try to ensure that draughts around doors, windows, letterboxes and keyholes etc., are reduced by using a suitable draught excluder.

Warning: do not block or seal any air vents that are installed to ensure the central heating boiler (or other appliance) operate safely.

TIPS ON ENERGY SAVING

Room thermostats:

Reducing the setting of the room thermostat by 1°C can reduce fuel consumption by up to 10%.

New control systems:

Upgrade your heating control system with the latest equipment available. The minimum level of control for a heating system is a programmer/timer, interlocking room thermostat and thermostatic radiator valves.

Radiators:

More often than not radiators will be sited underneath a window, so the warm air from the radiator heats the colder incoming air from the window.

The performance of the radiator will be affected if the curtains are allowed to drape over the radiator or shelves are fitted above it.

The positioning of furniture and tables in front of the radiator should also be avoided.

It is advisable to manually adjust all radiator valves every 2-3 months to prevent them from sticking. It is also important that the plastic tops of all valves are always in position and not cracked or damaged to help prevent accidents. Care should be taken when vacuum cleaning carpets to avoid damage to valves and pipework.

The heating system and the outputs of the radiators have been carefully selected by your installer. The temperature obtainable in any given room is dependent on all radiators being operated at the same time. If you decide to turn off radiators in unused rooms, spare bedrooms etc., you may experience slightly lower room temperatures in rooms adjacent to unheated rooms.

MAINTAINING YOUR APPLIANCE

Your new appliance represents a long term investment in a reliable, high quality product.

In order to realise its maximum working life and to ensure it continues to operate at peak efficiency and performance, it is essential that servicing and maintenance checks are performed at least once a year by a competent person.

If you would like to know more about servicing options from Worcester, Bosch Group please visit **www.worcester-bosch.co.uk**. Please tick the appropriate box on your warranty registration card for further details on the Worcester, Bosch Group service contract.

In addition to the service contract we are pleased to offer a one-off annual service or breakdown cover.

When your appliance requires servicing please contact the Worcester, Bosch Group contact centre (see inside front cover for details).

Maintenance tips:

Regularly check the oil level in the tank.

Regularly check the system pressure, ask your installer for guidance.

Do not obstruct the flue outlet or the air inlet.

FAULT FINDING

Problem	Cause	Remedy
Desired room temperature is not reached	Thermostatic radiator valve(s) set too low	Increase thermostatic radiator valve setting(s)
	Room thermostat set too low	Increase room thermostat setting
	Temperature control for flow on boiler set too low	Increase temperature control setting
	Air trapped in heating system	Bleed radiators, if fitted to a sealed system recharge heating system
Desired room temperature exceeded by large amount	Radiators are too hot	Turn down thermostatic radiator valves / room stat
Temperature rises instead of falling	Clock is incorrectly set	Check setting
No display or display unit does not respond	Momentary power failure	Switch off appliance at master switch, wait a few seconds then switch on again
Hot water temperature too low	Hot water tank temperature set too low	Check setting
	Hot water not in timed period on the programmer	Check programmer settings
	Temperature control on boiler set too low	Check setting

FAULT OR BREAKDOWN

This appliance is supported in the UK by Worcester, Bosch Group, part of BBT Thermotechnology UK Ltd.

Specialist factory trained Service Engineers are available to attend in the unlikely event that a breakdown occurs on this appliance.

No charge will be made for parts and/or labour providing:

- ▶ An appliance fault is found and the appliance has been installed within the past 24 months
- ▶ Reasonable evidence of this must be supplied on request
- ▶ **A call-out charge will be made where:**
- ▶ The appliance has been installed for over 24 months OR
- ▶ Our Field Service Engineer finds no fault with the appliance (see Note). OR
- ▶ Evidence cannot be provided that the first year service inspection has been carried out. (i.e. an entry in the service interval record found at the rear of the appliance installation and servicing manual). OR
- ▶ The cause of breakdown is misuse or with other parts of your plumbing/heating system, or with equipment not supplied by BBT Thermotechnology UK Ltd.

Note: NO APPLIANCE FAULT IS FOUND ON OVER 30% OF ALL SERVICE CALL OUTS.

Please read this guide carefully to gain a good understanding of the operation of your appliance. In the case of a suspected fault, refer to the fault finding section of this guide.

If in doubt contact Worcester, Bosch Group quoting the boiler serial and model number. These numbers are printed on a Data Label which is located as shown opposite. (You can record this information on the inside back cover of this manual.)

In the unlikely event of an appliance fault or breakdown please call the contact centre (see inside front cover for details). Your service administrator will arrange for an Engineer to call with the minimum of delay. Under normal

circumstances this will be from 1 to 3 working days (excluding weekends) for priority breakdown situations (no hot water and/or heating).

Invoices for attendance and repair work carried out on this appliance by any third party will not be accepted.

Utility and Utility System models:

APPLIANCE DATA LABEL

The data label can be found on the inside of the right hand side panel.

To access first remove the front panel:

- ▶ Gently pull front panel to release lugs and remove from appliance.

To replace front panel:

- ▶ Gently push the panel in to place (from the edges so as not to damage the panel) until the studs locate in their connectors.

DATA LABEL

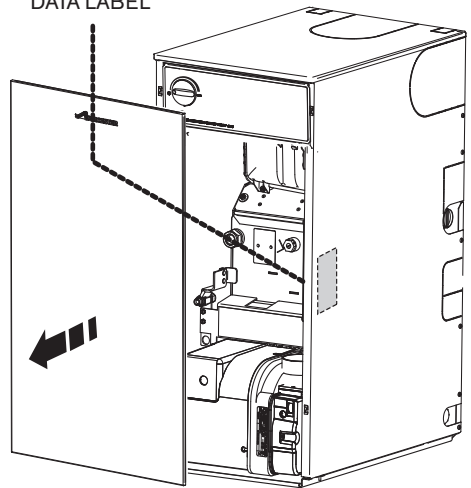

Utility shown.

YOUR GUARANTEE

This appliance is guaranteed against faulty materials or workmanship for a period of 24 calendar months (60 months for the primary heat exchanger) from the date of installation subject to the following conditions:

- ▶ That during the period of this guarantee any components of the unit which are proved to be faulty or defective in manufacture will be exchanged or repaired free of material charges and free of labour charges if repaired directly by BBT Thermotechnology UK Ltd. Invoices for attendance and repair of this appliance by third parties will not be accepted for payment by BBT Thermotechnology UK Ltd.
- ▶ That the householder may be asked to prove the date of installation, that the appliance was correctly commissioned and that the 12 month service has been carried out to the satisfaction of BBT Thermotechnology UK Ltd, when requested. The guarantee card must then be returned within 30 days of installation.
- ▶ That any product or part thereof returned for servicing under the guarantee must be accompanied by a claim stating the Model, Serial Number and Date of Installation.
- ▶ That BBT Thermotechnology UK Ltd will not accept responsibility for damage caused by faulty installation, neglect, misuse, accidental damage or non-observance of the instructions contained in the Installation and Users Instructions leaflets.
- ▶ That the appliance has been used only for normal domestic purposes, for which it was designed.
- ▶ That this guarantee applies only to equipment purchased and used in mainland Great Britain.

This guarantee is given in addition to all your normal statutory rights.

Worcester, Bosch Group is a trading name of BBT Thermotechnology UK Ltd.

GUARANTEE REGISTRATION

You should complete and return the postpaid Guarantee Registration Card within 30 days of installation.

Returning your card will register you as the owner of your new appliance and will assist us in maintaining an effective and efficient customer service by establishing a reference and permanent record for your boiler.

This does not affect your statutory rights.

For your own record:

Model _____

Serial No. _____

(See identity label inside appliance casing)

Type / size _____

Date of installation _____

Installer details _____

NOTES

NOTES

USER INSTRUCTIONS & CUSTOMER CARE GUIDE

EXCELLENCE COMES AS STANDARD

Worcester, Bosch Group

Cotswold Way, Warndon, Worcester WR4 9SW.

Tel. 01905 754624 Fax. 01905 754619

www.worcester-bosch.co.uk

Worcester, Bosch Group is a brand name of BBT Thermotechnology UK Ltd.

8 716 111 983a (02.07)



WORCESTER
Bosch Group