

**V E R I N E**  
FIRES ✦ TO ✦ INSPIRE

# Meridian MK2

**CONVENTIONAL FLUE LOG EFFECT GAS FIRE**

**Installation, Maintenance & User Instructions**

**Hand these instructions to the user**

**Model No's NHEL\*\*RN2 is only for use on Natural Gas (G20) at a supply pressure of 20 mbar in G.B. / I.E.**

**Model No's NHEL\*\*RP2 is only for use on Propane Gas (G31) at a supply pressure of 37 mbar in G.B. / I.E.**

**\*\* denotes cosmetic variant**

# CONTENTS

<b>Section 1</b>	<b>Information and Requirements</b>	<b>PAGE</b>
1.0	Appliance Information	3
1.1	Conditions of Installation	4
1.2	Flue and chimney suitability	4
1.3	Fireplace / surround suitability	5
1.4	Shelf position	5
1.5	Chimney inspection	5
1.6	Fire place opening / catchment space	6-7
1.7	Fitting to Chair bricks	7
1.8	Metal Flue boxes	7
1.9	Hearths	7-8
1.10	Wall Mounting	8
1.11	Spillage Monitoring System	9
<b>Section 2</b>	<b>Installation of Fire</b>	
2.1	Unpacking the fire	10
2.2	Installing the fire box	10-17
2.3	Fitting the batteries to the receiver unit & handset	17
2.4	Gas tightness and inlet pressure	18
<b>Section 3</b>	<b>Assembling Fuel Bed and Commissioning</b>	
3.1	Fitting the log fuelbed	19-23
3.2	Lighting the appliance	24-25
3.3	Checking for clearance of combustion products	26
3.4	Removal / re-fitting the restrictor baffle	27
3.5	Removal / re-fitting the trim assembly	28-29
<b>Section 4</b>	<b>Maintenance</b>	
4.1	Removal of the burner assembly	30
4.2	Removal of the control valve	30
4.3	Removal of the oxypilot	31
4.4	Removal of the receiver unit	31
	Spare parts shortlist	32
<b>Section 5</b>	<b>User Instructions Section</b>	
5.1	Conditions of installation / about your new gas fire	33-34
5.2	Operating the fire	35-36
5.3	Removal / re-fitting the glass frame assembly	37-38
5.4	Removal / replacement of the fuelbed	39-43
5.5	Cleaning the fire	43-44
5.6	Removal / re-fitting the trim	45
	User replaceable parts	46

This appliance is manufactured by :-

BFM Europe Ltd.  
Trentham Lakes,  
Stoke-on-Trent, ST4 4TJ.

## SECTION 1 INFORMATION AND REQUIREMENTS

### 1.0 APPLIANCE INFORMATION

Model	NHEL**RN2	NHEL**RP2
	** denotes cosmetic variant of product	
	NG	LPG
Gas Type	G20	G31
Main injector (1 off)	Size 380	Size 120
Pilot Type	Seagas P4-29D	Seagas P5-30
Max. Gross Heat Input :	6.2 kW	5.4 kW
Min. Gross Heat Input :	4.8 kW	3.5 kW
Cold Pressure :	20.0 +/-1.0 mbar	37.0 +/-1.0 mbar
Ignition :	6V Battery Ignition	6V Battery Ignition
Electrode Spark Gap	4.0mm	4.0mm
Packed Weight	35 kg	35 kg

#### **Fire box Dimensions (with trim fitted)**

Width :	(with trim fitted)	600mm
Height :	(with trim fitted)	752mm
Depth :	(from mounting face to rear panel)	205mm

Gas Connection :            8mm Compression            (Supplied with fire)

#### **Appliance Efficiency Declaration**

**The efficiency of this appliance has been measured as specified in BS 7977-1 : 2002 and the result is 68%.**

**The gross calorific value of the fuel has been used for this efficiency calculation.**

**The test data from which it has been calculated has been certified by BSI. The efficiency value may be used in the UK Government's Standard Assessment Procedure (SAP) for energy rating of dwellings.**

# INSTALLATION REQUIREMENTS

## 1.1 CONDITIONS OF INSTALLATION

It is the law that all gas appliances are installed only by a GAS SAFE Registered Installer, in accordance with these installation instructions and the Gas Safety (Installation and Use) Regulations 1998 as amended. Failure to install appliances correctly could lead to prosecution. It is in your own interest and that of safety to comply with the law.

The installation must also be in accordance with all relevant parts of the Local and National Building Regulations where appropriate, the Building Regulations (Scotland Consolidation) issued by the Scottish Development Department, and all applicable requirements of the following British Standard Code of Practice.

1. B.S. 5871 Part 2 Installation of Inset Fuel Effect Gas Fires
2. B.S. 6891 Installation of Gas Pipework
3. B.S. 5440 Parts 1 & 2 Installation of Flues and Ventilation
4. B.S. 1251 Open fire place components
5. B.S. 715 Metal flue pipes for gas appliances
6. B.S. 6461 Part 1 Installation of Chimneys and flues
7. B.S. E.N. 1858 Chimneys Components & Concrete Flue Blocks
8. I.S. 813 : 1996 Domestic Gas Installation (Republic of Ireland)

**No purpose made additional ventilation is normally required for this appliance, when installed in G.B. When installing in I.E. please consult document I.S. 813 : 1996 Domestic Gas Installation, which is issued by the National Standards Authority of Ireland. If installing in Northern Ireland, please consult local building regulations. Any purpose made ventilation must be checked periodically to ensure that it is free from obstruction.**

## 1.2 FLUE AND CHIMNEY SUITABILITY

This appliance is designed for use with conventional brick built or lined chimneys and fabricated flues conforming to BS 715. All flues must conform to the following minimum dimensions.

<b>Minimum diameter of circular flues</b>	<b>125 mm (Without Flue Restrictor Fitted)</b>
<b>Minimum effective height of all flue types</b>	<b>3 metres</b>

**When fitting to conventional chimneys or 175mm flues it may be desirable to leave the flue restrictor baffle (supplied) in place to reduce the flue flow and increase the efficiency of the fire. Safe clearance of products must always be checked by carrying out a smoke match test as described.**

### 1.3 FIREPLACE / SURROUND SUITABILITY

The fire must only be installed on a hearth it **must not be installed directly onto carpet or other combustible floor materials.** The fire is suitable for fitting to non-combustible fire place surrounds with a temperature rating of at least 150<sup>o</sup>c. (Class "O")

**If a heating appliance is fitted directly against a wall without the use of a fire surround or fire place all combustible material must be removed from behind the trim. Soft wall coverings such as blown vinyl, wall paper etc. could be affected by the rising hot air and scorching and/or discoloration may result. Due consideration should be made to this when installing or decorating.**

### 1.4 SHELF POSITION

The fire may be fitted below a combustible shelf providing there is a minimum distance of 200mm above the top of the fire and the shelf does not project more than 150mm. If the shelf overhangs more than 150mm the distance between the fire and the shelf must be increased by 15mm for every 25mm of additional overhang over 150mm.

### 1.5 FLUE / CHIMNEY INSPECTION

Before commencing installation, a flue or chimney should be inspected to ensure that all the following conditions are satisfied.

1. Check that the chimney / flue only serves one fire place and is clear of any obstruction. Any dampers or register plates must be removed or locked in the open position.
2. Brick/stone built chimneys or any chimney or flue which has been used for an appliance burning fuel other than gas must be thoroughly swept. The base of the chimney / flue must also be thoroughly cleared of debris etc.
3. Any under-floor air supply to the fire place must be completely sealed off.
4. Ensure that the inside of the chimney / flue is in good condition along its length and check that there is no leakage of smoke through the structure of the chimney during and after the smoke pellet test. **With pre-cast flues it is especially important to check the inside of the flue for extruded cement / sealant protruding from the joints between the flue blocks. If present, these should be removed by rodding the flue before proceeding with the installation.**
5. **Using a smoke pellet, check that there is an up-draught in the chimney / flue and that the smoke can be seen issuing from the terminal / chimney pot outside.**

**There must be no leakage of smoke through the structure of the chimney during or after the smoke pellet test and it is important to check inside upstairs rooms adjacent to the chimney / flue.** Check the chimney pot / terminal and general condition of the brickwork or masonry. If the chimney or flue is in poor condition or if there is no up-draught do not proceed with the installation. If there is a history of down-draught conditions with the chimney / flue, a tested and certificated flue terminal or cowl suitable for the relevant flue type should be considered.

6. **A spillage test must always be carried out during commissioning of the appliance.**

### 1.6 FIRE PLACE OPENING AND CHIMNEY CATCHMENT SPACE

The front opening of the fire place must be between 550 and 565mm wide, and between 720 and 730mm high. If the opening exceeds these dimensions then a surround must be constructed from suitable non-combustible material to produce a correct size opening. Any surround must be suitably sealed to the fire place to prevent leakage. See below in fig.1

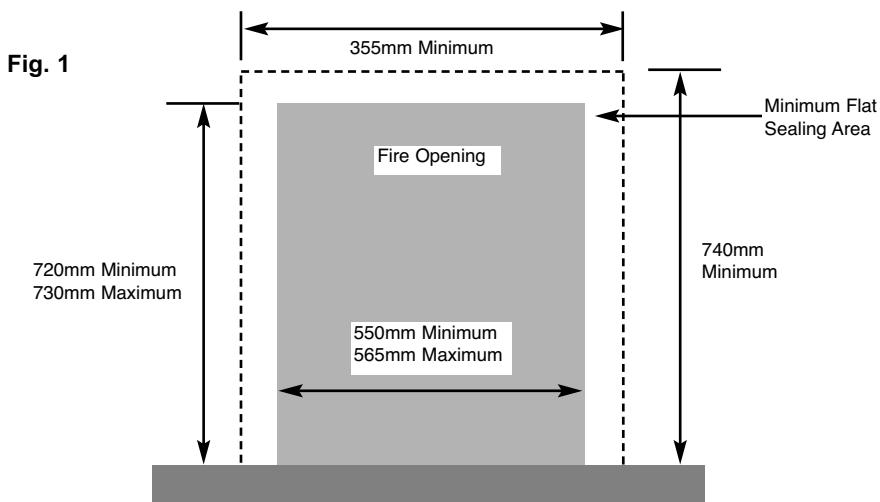

When installing into a brick built chimney, you must ensure that there is sufficient depth to accommodate any debris which may fall from the chimney. This depth must be sufficient to accommodate 12 litres of volumetric space in a conventional brick built chimney.

**Table A - Installation Depth Requirements for a Verine Meridian being installed into a brick built chimney, requiring 12.0 litres of debris collection volume (fig. 2).**

Opening Width (mm)	Minimum Depth Required (mm)
550-565mm	265mm

**Fig. 2**

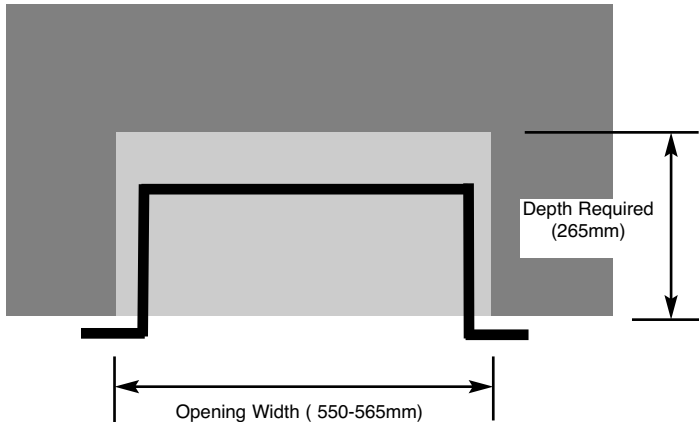

**1.7 FITTING TO FIREPLACES WITH EXISTING CHAIRBRICKS AND CONVENTIONAL BRICKBUILT CHIMNEYS**

This appliance is not suitable for use in fireplaces fitted with an existing chairbrick without the removal of the chairbrick.

**1.8 FITTING TO PRE-FABRICATED TWIN WALL METAL FLUE BOXES**

The appliance may be fitted to twin wall metal flue boxes conforming to the constructional requirements of BS 715. The box must have a minimum flue diameter of 125mm internal and minimum internal dimensions of 235mm deep by 720mm high by 550mm wide. The top face of the box must be insulated with a minimum thickness of 50mm of non-combustible mineral wool insulation or similar material. The flue box must stand on a non-combustible base of minimum thickness 12mm.

**1.9 HEARTHES**

This appliance must only be installed on to a concrete or non-combustible hearth. The hearth material must be a minimum thickness of 12mm with the top surface at least 50mm above the floor. The hearth must be fitted symmetrically about the fire

opening and have a minimum width of 760mm and a minimum projection of 300mm forwards from the fire opening. If you wish to fit the product in a “hole in the wall” style installation, please consult section 1.10

### 1.10 WALL / HEARTH MOUNTING

This appliance must be fitted on a flat, non-combustible base of minimum thickness 12mm. In addition, a non-combustible hearth or physical barrier should be provided in front of the fire.

With “hole in the wall” type installations, where it may be desirable not to fit a hearth panel or physical barrier, the product may be installed in accordance with Document J of the building regulations so that every part of the flame or incandescent material is at least 225mm above the floor level. For the customers safety, and in accordance with BS 5871-2, the fitting of a hearth panel or physical barrier should be carried out. Should this advice not be followed however, please give consideration to the safety of the occupants in the room to which the appliance is installed.

Any hearth panel or physical barrier that is fitted should project a minimum of 300mm forwards from the fire opening and 150mm either side of the fire opening, as shown below in Fig. 3. Any physical barrier must be securely fixed and be of robust design.

Fig. 3

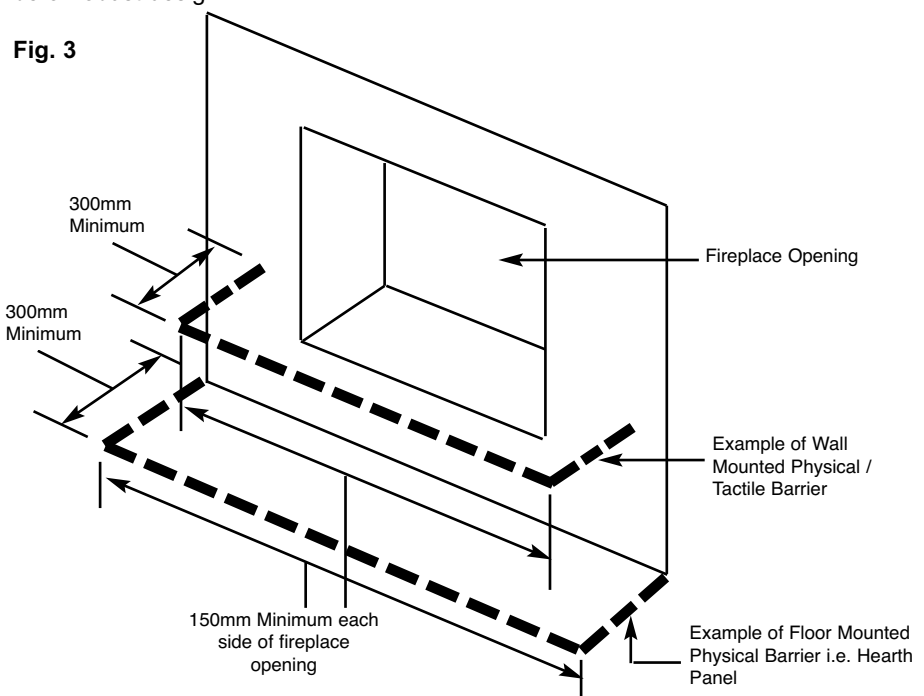



## 1.10 SPILLAGE MONITORING SYSTEM

This appliance is fitted with an atmosphere sensing spillage monitoring system in the form of an oxygen sensing burner. This is designed to shut the fire off in the event of a partial or complete blockage of the flue causing a build up of combustion products in the room in which the fire is operated. **The following are important warnings relating to this spillage monitoring system :-**

- 1) The spillage monitoring system must not be adjusted by the installer.
- 2) The spillage monitoring system must not be put out of operation.
- 3) When the spillage monitoring system is exchanged only a complete original manufacturers part may be fitted.

## SECTION 2 INSTALLATION OF FIRE

### 2.1 UNPACKING THE FIRE

Carefully lift the fire out of the carton. Remove the loose item packaging carefully from the front of the appliance. Check the contents as listed :-

#### Packing Check List - All Models

- 1 off Firebox / burner assembly
- 1 off Boxed ceramic log effect fuel-bed (packed inside combustion chamber)
- 1 off Cosmetic trim
- 1 off Loose items bag inc handset, 4 off 1.5V batteries & 1 off 9V battery
- 1 off Trim (colour / finish dependent upon model chosen)
- 1 off Installation / user book (combined)

### 2.2 INSTALLING THE FIRE BOX

Establish which type of flue you are intending to install the fire in to :-

**225 x 225mm (9 inch x 9 inch) brick built chimneys**

**175mm (7 inch) diameter lined brick or stone flue, or insulated pre-fabricated metal flue box to B.S. 715.**

**When installing into 125mm (5 inch) diameter lined brick or stone flue, or insulated pre-fabricated metal flue box to B.S. 715 and pre-cast flues the restrictor baffle must not be fitted.**

**A spillage test must always be carried out to check satisfactory clearance of flue products, regardless of the type of flue the appliance is being fitted to.**

- a) Remove the glass panel by undoing the retaining clips at the base of the glass frame as shown below in Fig. 4

**Fig. 4**

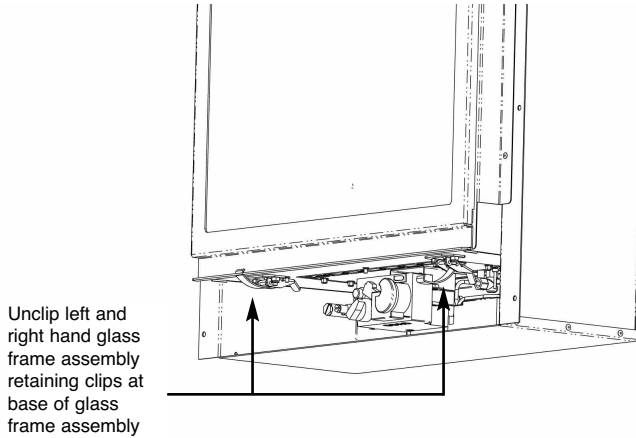

- b) Remove the glass frame assembly by tilting forwards then lifting as shown in Fig. 5 below

**Fig. 5**

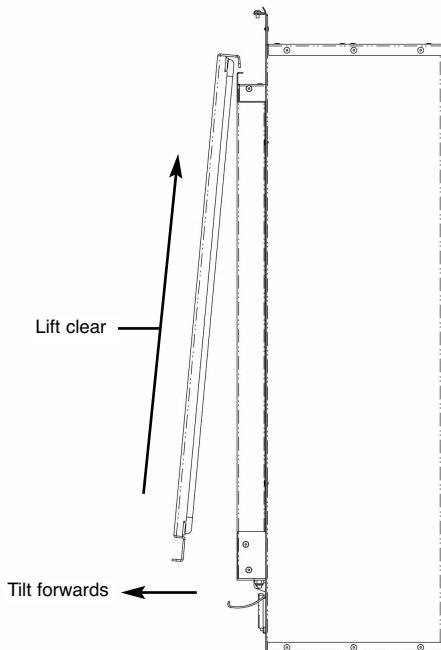

- c) Remove the burner. To allow burner removal, the ceramic support panel must be removed to allow access to the burner fixings. Remove the 4 off ceramic support retaining screws as shown below in Fig. 6

**Fig. 6**

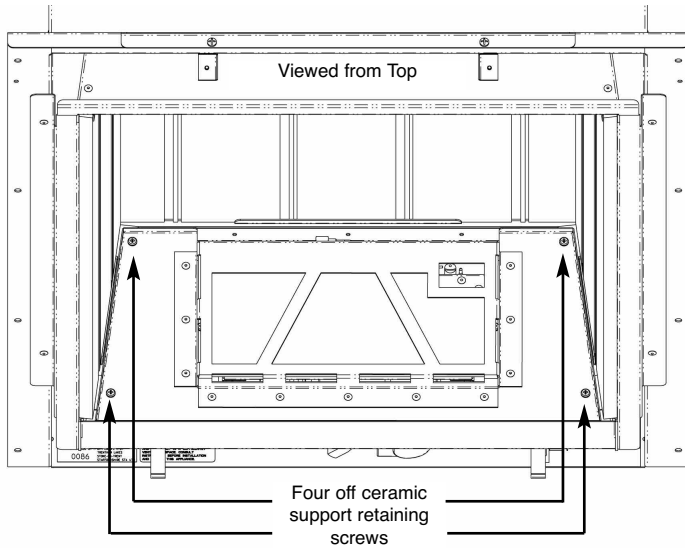

- d) Remove the 7 off screws that hold the burner in position, see Fig. 7 below.

**Fig. 7**

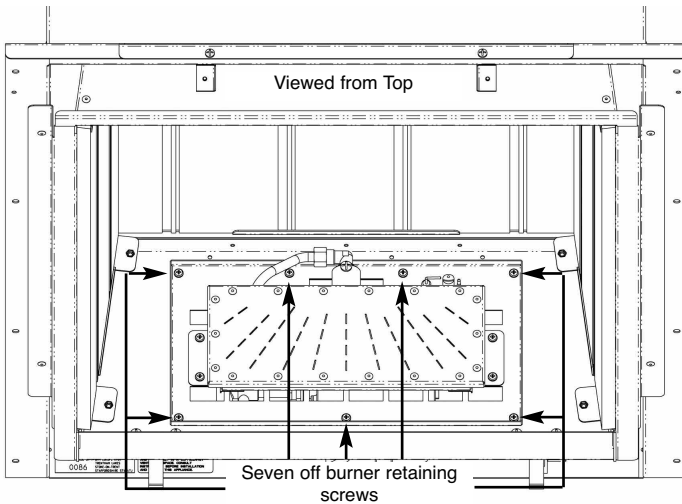

- e) Remove the burner by lifting clear from the combustion chamber as shown below in Fig. 8, take care to also lift out the receiver unit and wiring loom, (the receiver unit is held in position with velcro).

**Fig. 8**

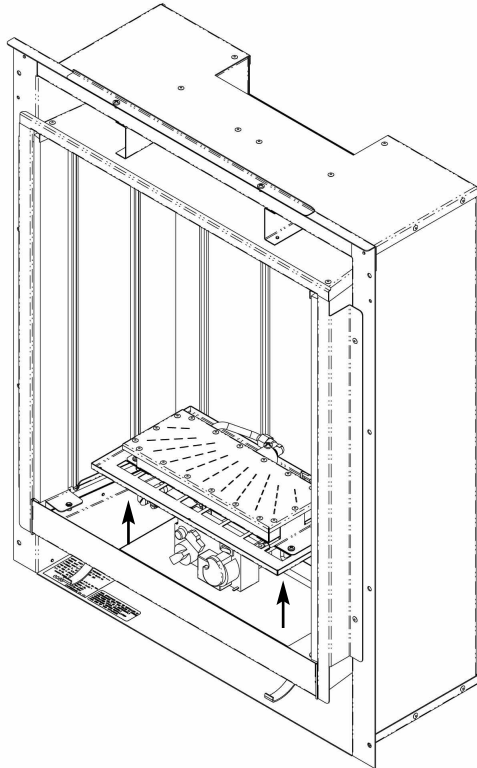

- f) Store the burner unit in a safe position.
- g) Ensure that the hearth is protected from damage and carefully lift the fire box into the fire opening, then slide it back into position. Check that the fire box flange fits flush to the sealing face of the fire surround or wall with no gaps present.

**Continue as follows for all models :-**

- h) Whilst the fire box is still in position, decide which side the gas supply is to enter the fire from. If concealed pipe work is required plan the pipe run to enter the fire box through one of the openings in the sides or rear of the fire box below the fuelbed support panel and connect to the isolating / inlet elbow. The gas connection to the appliance should be made to the isolating / inlet elbow using 8mm rigid tubing. There must be no soldered joints within the firebox. See fig. 9 & 10 below for suggested concealed pipe layouts.

**Fig. 9**

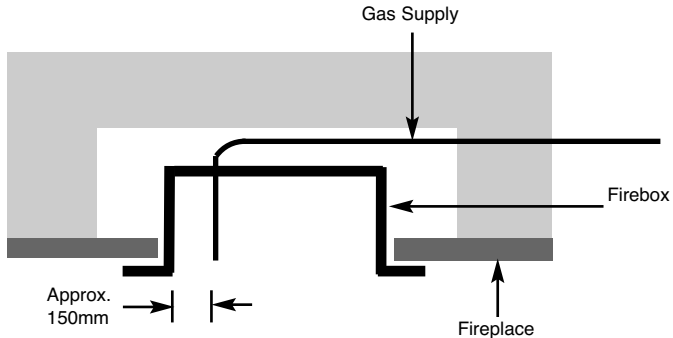

**Fig. 10**

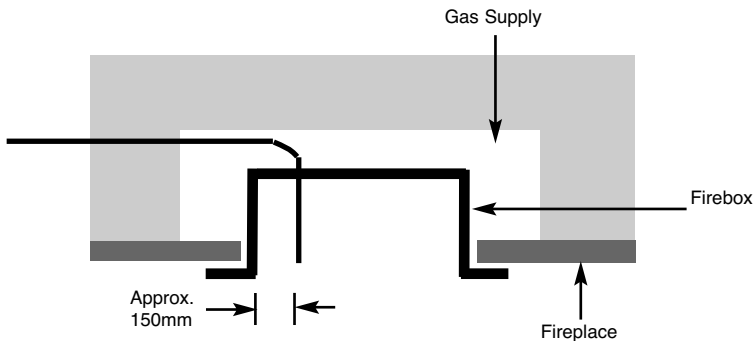

**Note : Before breaking into the gas supply a pressure drop test should be carried out to establish that the existing pipework is sound.**

- i) Carefully withdraw the fire box from the opening to enable the gas supply and fire fixing to be completed.

There is a choice of methods of fixing the firebox which are provided to enable the installer to deal with any type of installation.

**The preferred method of fixing which is suitable for almost all situations is the cable fixing method which is described in the following section in detail.**

The fire may be secured using the cable method as described below, or alternatively, in installations where the cable method is not suitable (eg. loose masonry in rear of fire opening) the fire box can be directly secured to the fire surround using screw fixings (not provided).

To fit using the **preferred** cable method proceed as follows-

- j) Mark out and drill 4 off No 14 (7mm) holes in the back face of the fire opening in the positions shown below in fig. 11

**Fig. 11**

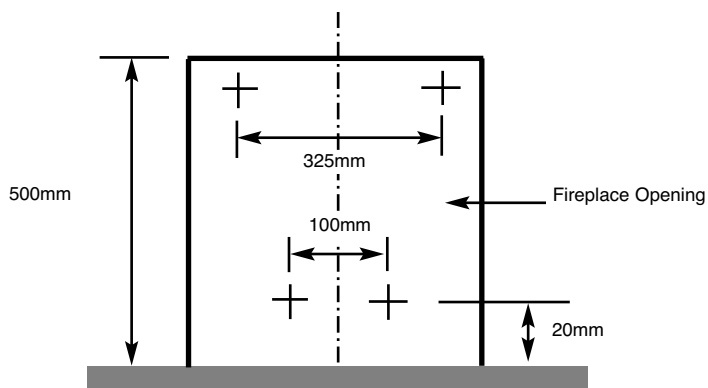

Fit the wallplugs provided and screw the fixing eyes securely into the rear of the fire opening. If the clearance at the rear of the fire is at the minimum specified for a precast flue application, it may be necessary to bend over the lower fixing eyes after screwing them fully in to the rear of a pre-cast starter block.

- k) Uncoil the two fire fixing cables and thread one end of each of the cables through one of the two holes on each side of the flue outlet shroud.
- l) Position the fire carefully on the (protected) surface of the hearth and reach into the fire opening. Thread each of the cables vertically

downwards through the pair of fixing eyes on the same side of the fire. Thread the free end of the cables through the corresponding circular hole on each side of the lower rear of the fire. Carefully slide the fire box back into the fire opening and pull both cables tight.

- m) Thread a tensioning screw over each of the cables and ensure that the tensioning nut is screwed fully up against the hexagon shoulder of the tensioning screw (this provides maximum travel for the tensioning nut).
- n) Fit a screwed nipple on to each of the cables and pull hand tight up against the tensioning screw, then secure each nipple with a flat bladed screwdriver. See fig. 12 below

Fig. 12

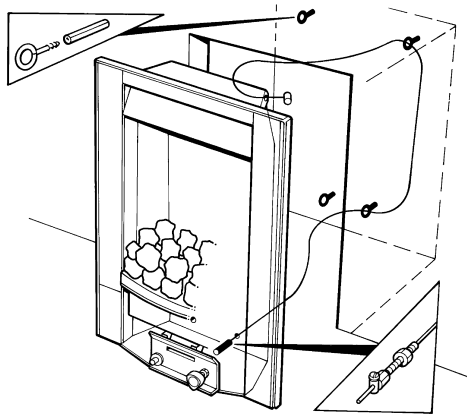

- o) Evenly tighten the tensioning nuts to tension both cables and pull the fire snugly against the wall. Do not overtighten, it is only necessary to pull the seal up against the sealing face of the wall, it does not need to be compressed. Check that there are no gaps behind the seal.
- p) With the fire securely in place, if a concealed gas connection has been made through either of the access holes in the sides or rear of the fire, the holes should be closed around the pipe to prevent leakage of air through the gap around the pipe.
- q) Refit the burner. Fit the 7 off retaining screws and check that the burner is correctly locked into position, then re-fit the ceramic support panel via 4 off screws.
- r) **Before making the final gas connection, thoroughly purge the gas supply pipework to remove all foreign matter, otherwise serious damage may be caused to the gas control valve on the fire.**



The other firebox fixing method is as follows :-

- s) In installations where the cable method is not suitable (e.g. loose masonry in rear of fire opening) the firebox can be secured to the fire surround using four screws and wall plugs (not provided). Below (Fig. 13) is a diagram to indicate the hole centre positions available on the firebox to facilitate the screw fixing to the fireplace / surround.

**Fig. 13**

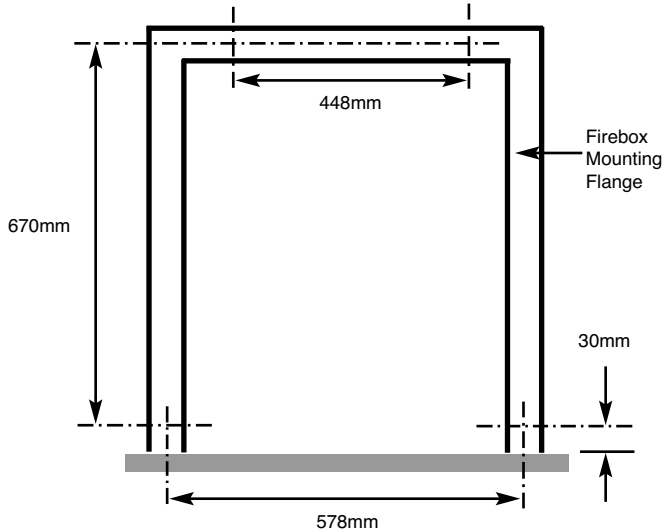

### **2.3 FITTING THE BATTERIES TO THE RECEIVER UNIT & HANDSET**

- a) 4 off AA 1.5V batteries (found in the loose items pack) are to be fitted to the battery holder located on the base of the fire below the combustion chamber.
- b) To remove the receiver unit, slide the unit forwards from it's retaining bracket.
- c) Slide off the cover from the reciever unit.
- d) Fit the 4 off AA batteries to the unit, then re-fit the cover.
- e) Replace the receiver into it's retaining bracket at the base of the fire.
- f) Fit the 1 off 9V battery to the handset by removing the rear cover, connecting the battery then replacing the cover.

## 2.4 GAS TIGHTNESS AND INLET PRESSURE

- a) Remove the pressure test point screw from the inlet elbow and fit a manometer.
- b) Turn on the main gas supply and carry out a gas tightness test.
- c) Depress both the round buttons on the handset. The fire will then commence its ignition sequence and will light to high. See section 3.2 for full details of the operating method for the fire.
- d) Check that the gas pressure is **20.0 mbar (+/- 1.0mbar) 8.0 in w.g.(+/- 0.4 in w.g.) for G20 (NG) models or 37.0 mbar (+/- 1.0mbar) 8.0 in w.g.(+/- 0.4 in w.g.) for G31 (LPG) models.**
- e) Turn off the fire, remove the manometer and refit the pressure test point screw. Check the pressure test point screw for gas tightness with the appliance turned on using a suitable leak detection fluid or detector.

## SECTION 3

### 3.1 ASSEMBLING THE LOG FUEL-BED

- a) Place the L/H and R/H ceramic base pieces onto the ceramic support panel as shown below in Fig. 14

Fig. 14



- b) Place the front ceramic base piece onto the ceramic support ensuring the location tabs fit into the L/H & R/H ceramic base pieces as shown below in Fig. 15

Fig. 15



- c) Place the base log onto the ceramic support panel as shown below in Fig. 16, ensuring the spacer locating blocks on the rear face are fitted flush up against the rear panel.

**Fig. 16**

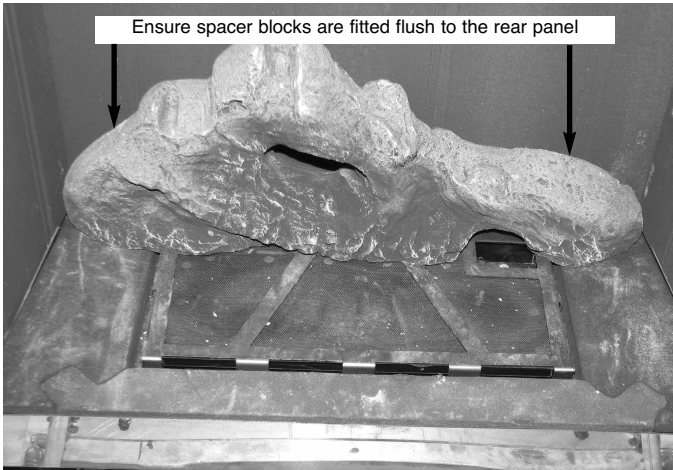

- d) Cover the burner and fuel-bed base ceramic in a single, even layer of bark chippings as shown below in Fig. 17

**Fig. 17**



- e) Position log “H” onto the base log using the location lug on the back face of log “H” and the groove on the base log to find the correct location, as shown below in Fig. 18

**Fig. 18**



- f) Position log “E” onto the base log using the location lug on the back face of log “E” and the groove on the base log to find the correct location as shown below in Fig. 19

**Fig. 19**

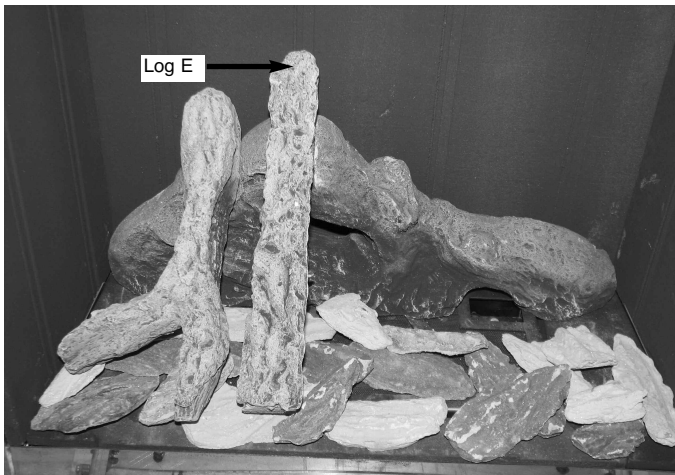

- g) Position log "B" onto the base log using the location lug on the back face of log "B" and the groove on the base log to find the correct location as shown below in Fig. 20

**Fig. 20**



- h) Position log "G" onto the base log using the location lug on the back face of log "G" and the groove on the base log to find the correct location as shown below in Fig. 21

**Fig. 21**



- i) Re-fit the glass frame assembly as shown on page 11 before proceeding to section 3.2

**Warning : Use only the log fuel-bed supplied with the fire. When replacing the log fuel-bed remove the old log fuel-bed and discard it. Fit a complete log fuel-bed from the manufacturer, only use genuine replacements.**

**THE FOLLOWING STATEMENT IS APPLICABLE TO ALL FUEL-BED TYPES**

**This appliance uses fuel effect pieces containing Refractory Ceramic Fibres (R.C.F.), which are man-made vitreous silicate fibres. Excessive exposure to these materials may cause temporary irritation to eyes, skin and respiratory tract. Consequently, it makes sense to take care when handling these articles to ensure that the release of dust is kept to a minimum. To ensure that the release of fibres from these R.C.F. articles is kept to a minimum, during installation & servicing we recommend that you use a HEPA filtered vacuum to remove any dust and soot accumulated in and around the fire, before and after working on the fire. When replacing these articles we recommend that the replaced items are not broken up, but are sealed within a heavy duty polythene bag, clearly labelled as “RCF waste”. This is not classified as “hazardous waste” and may be disposed of at a tipping site licensed for the disposal of industrial waste. Protective clothing is not required when handling these articles, but we do recommend you follow the normal hygiene rules of not smoking, eating or drinking in the work area, and always wash your hands before eating or drinking.**

**This appliance does not contain any component manufactured from asbestos or asbestos related products.**

### 3.2 LIGHTING THE APPLIANCE

- a) The control valve is positioned centrally below the burner unit of the fire when viewed from the front.
- b) To operate the appliance automatically via the remote control handset, ensure that the on / off switch is switched to the “on” position as shown below in Fig. 22

**Fig. 22**

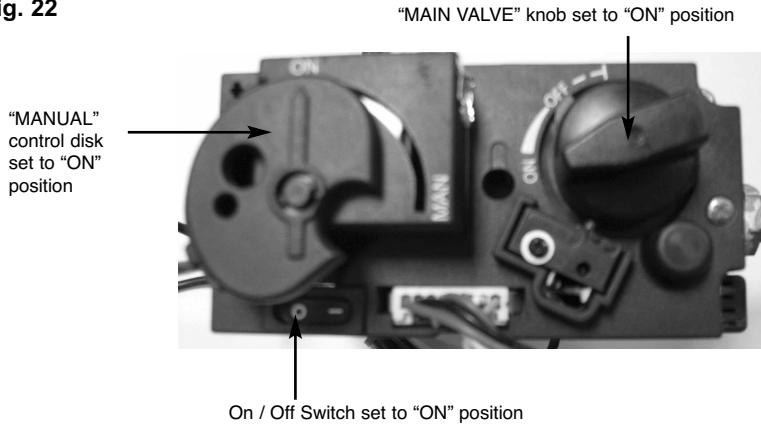

- c) Switch the MANUAL control disc to the “on” position, (as shown above in Fig. 22)
- d) Switch the main valve knob to the “ON” position. (as shown above in Fig. 22)
- e) Press and hold the “STAR” button and “UP” button on the remote handset simultaneously, see Fig. 23 overpage for image of handset.
- f) The valve will then emit an audible beep and commence its ignition sequence. When the pilot flame has been established, the control will continue to beep whilst the thermocouple heats up. When the thermocouple has reached operating temperature, it will allow gas to flow to the burner and the burner will light at high rate heat input (6.2kW NG models, 5.4kW LPG models).



- g) To reduce the heat input, press the “DOWN / STANDBY” button until the flame reduces to the low rate heat input setting (4.8kW NG models, 3.5kW LPG models). If you continue to hold the “DOWN / STANDBY” button, the burner flame will extinguish, and only the pilot flame will remain lit. If you wish to turn off the fire altogether, press the “STAR” / “OFF” button.

**AFTER THE PILOT FLAME HAS BEEN EXTINGUISHED, IF YOU WISH TO RE-LIGHT THE APPLIANCE YOU MUST WAIT AT LEAST THREE MINUTES BEFORE TRYING TO RE-LIGHT THE FIRE.**

- h) Should the handset be misplaced, you can turn the fire off by switching the “ON / OFF” switch to the “OFF” position.

**Fig. 23**

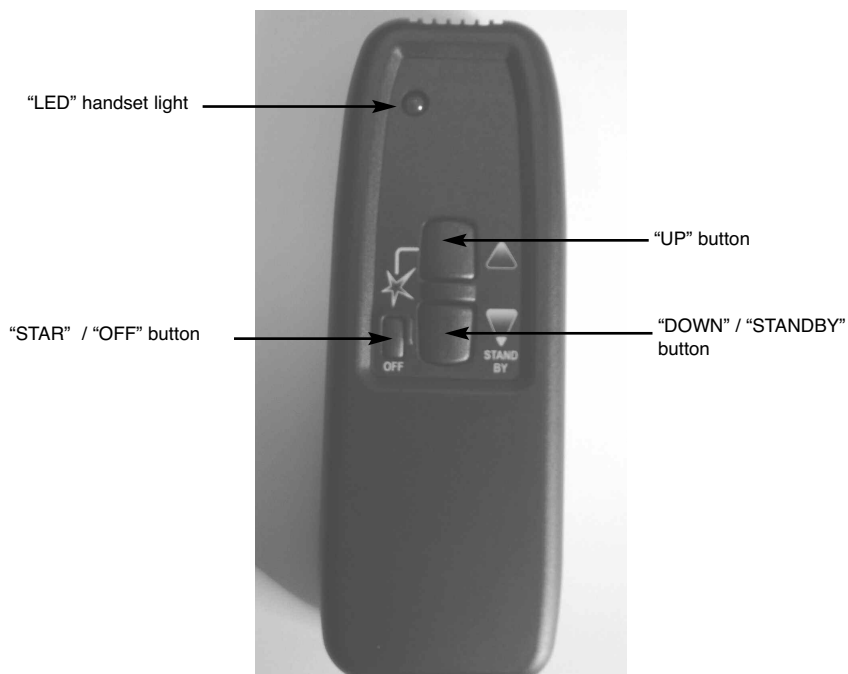

### 3.3 CHECKING FOR CLEARANCE OF COMBUSTION PRODUCTS

- a) Close all doors and windows in the room.
- b) Light the fire and allow to run for approximately 5 minutes on high position.
- c) After approximately 5 minutes hold a smoke match just 10mm inside and below the centre of the lower front edge of the top of the fire, as shown below in Fig. 24 (It is recommended that a suitable smoke match holder is used when checking for clearance of combustion products). All smoke generated should be drawn back into the flue. If slight spillage occurs or if in doubt, repeat the test after a further 5-10 minutes. **If the test indicates that spillage is occurring and the flue restrictor baffle has been fitted, it should be removed as shown in section 3.4 and the test repeated after the fire has cooled.**
- d) If spillage persists, the flue is not functioning correctly and a fault exists. If, after investigation the fault cannot be traced and rectified, the fire must be disconnected from the gas supply and expert advice obtained.
- e) If there is an extractor fan fitted any where in the vicinity of the appliance, or in adjacent rooms the spillage test should be repeated with the fan running on maximum and all interconnecting doors open.
- f) After ensuring that the fire is safe to use it should be left on high position to fully warm up. During this time a slight odour may be noticed, this is due to the “newness” of the fire and will soon disappear. Finally, hand the Installation and Maintenance Instructions and the Users Instructions over to the customer and explain the operation of the fire.

Fig. 24

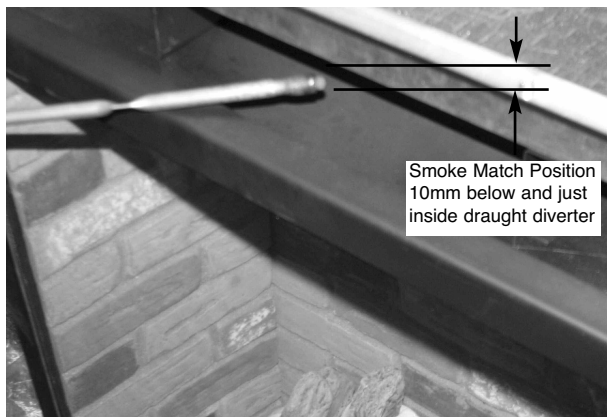

### 3.4 REMOVING / RE-FITTING THE FLUE RESTRICTOR BAFFLE

- a) The restrictor baffle is secured with 2 off screws to the spigot area of the fire.
- b) Remove the fire if necessary from the fireplace opening and unscrew or re-fit the baffle as shown below in Fig. 25

Fig. 25

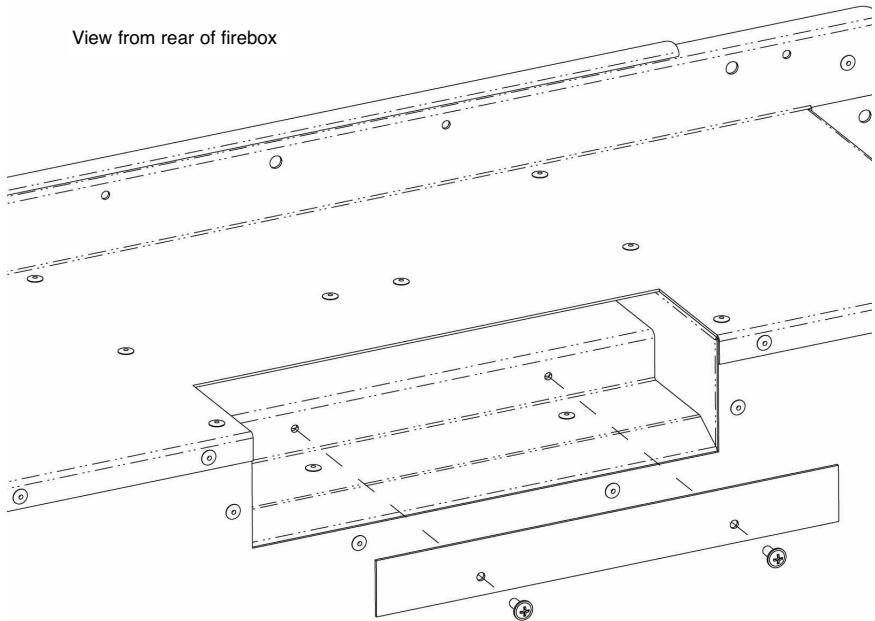

- c) Re-check the spillage test as required.

### 3.5 REMOVING / RE-FITTING THE TRIM ASSEMBLY & COSMETIC TRIM

- a) The trim is secured by hooking the trim over the bracket on the top flange of the firebox as shown below in Fig. 26. The bracket is adjustable to ensure the fit is correct.

Fig. 26

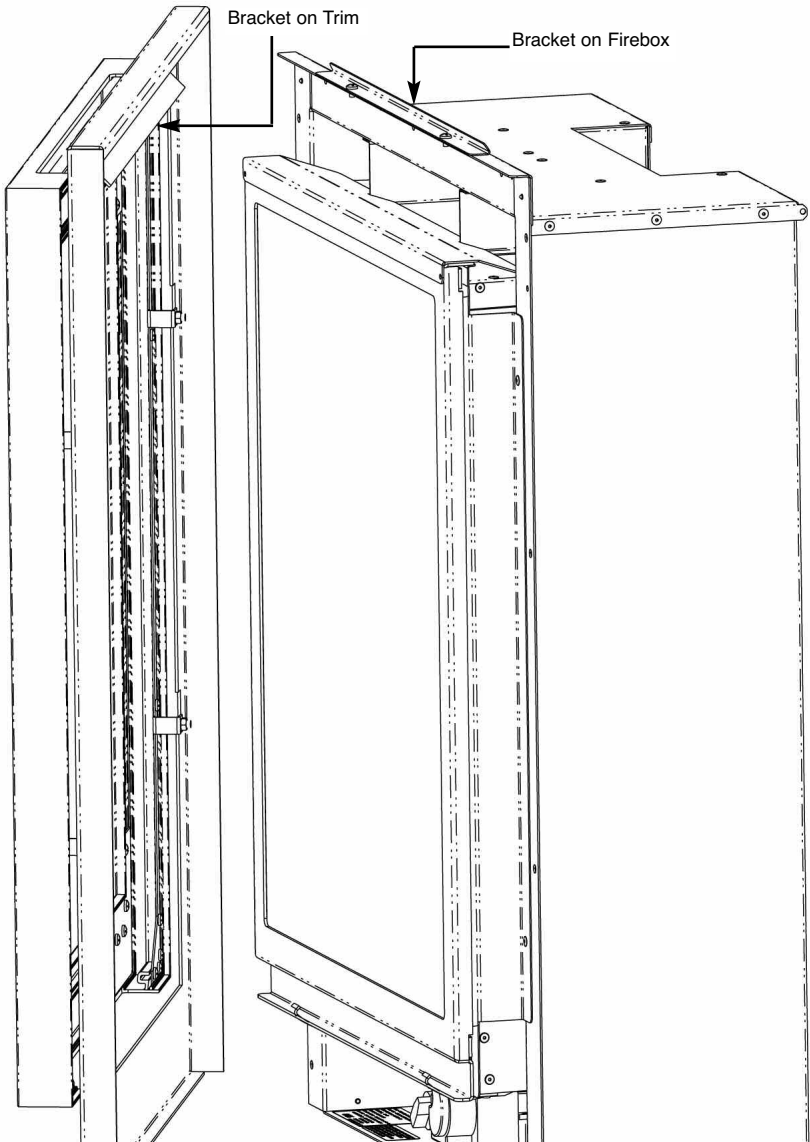

- b) Fit the cosmetic trim over the glass frame assembly as shown below in Fig. 27

**Fig. 27**

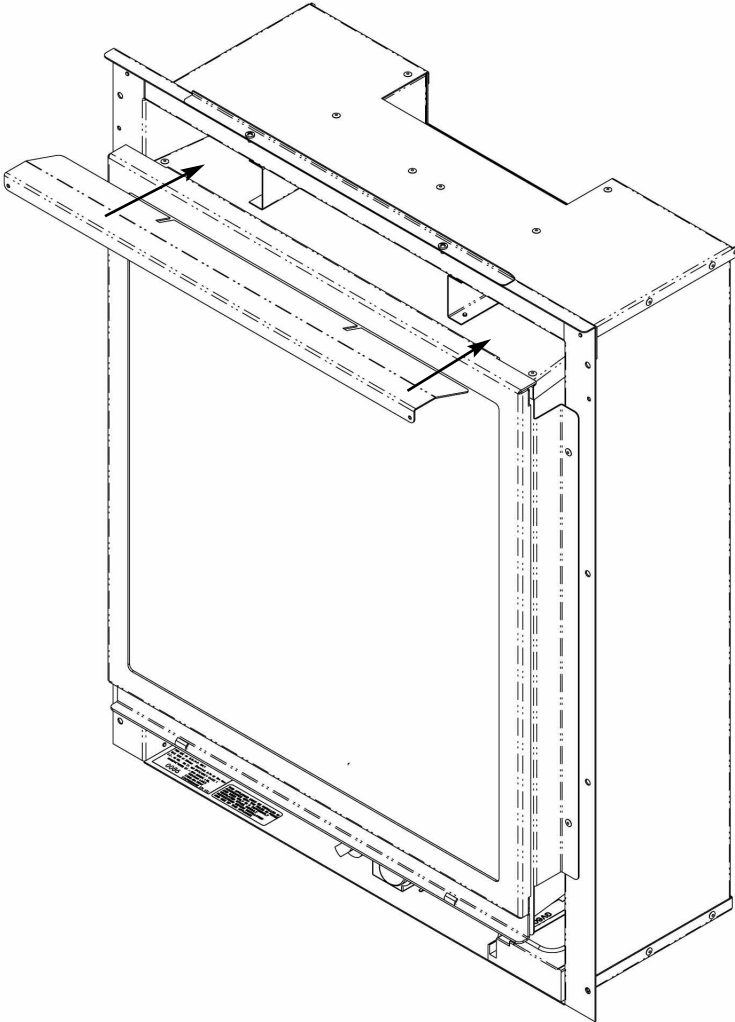

## SECTION 4 MAINTENANCE

### Servicing Notes

Servicing should be carried out annually by a competent person such as a GAS SAFE registered engineer. **This is a condition of the Verine guarantee schemes.**

The service should include visually checking the chimney and fire opening for accumulations of debris and a smoke test to check for a positive up-draught in the chimney. The oxypilot on the burner unit must also be changed as a condition of the guarantee. The condition of the fuel-bed should be checked and **if necessary the whole item should be replaced with a genuine replacement item.** The burner assembly is designed to be removed as a complete unit for ease of access. **After any servicing work a gas tightness check must always be carried out.**

### For Diagrams refer to Section 2

#### 4.1 Removing the burner assembly from the fire.

4.1.1 Prepare work area (lay down dust sheets etc.)

4.1.2 Remove the trim. Remove the glass assembly, remove the ceramic logs.

4.1.3 Isolate the gas supply and remove the supply pipe from the appliance inlet elbow. Unscrew and remove the four screws which retain the ceramic support plate to the base, then lift clear. Remove the seven screws which hold the burner in position & then remove the burner assembly from the fire.

4.1.4 To refit the burner assembly, locate the burner unit and refit the seven screws. Refit the ceramic support plate and four screws. Refit the gas supply pipe and carry out a gas tightness test. Refit the fuel-bed referring to section 3 for the correct log positions. The trim and cosmetic trim can now be re-fitted.

#### 4.2 Removing the Gas Control Valve

4.2.1 Remove the burner assembly as detailed in section 4.1

4.2.2 Remove the thermocouple retaining nut from the valve, remove the main pipe, inlet pipe, pilot pipe and thermocouple interrupter / wires from the valve.

4.2.3 Remove the valve retaining screws and remove the valve. Re-assemble in reverse order and carry out a gas tightness test.

### **4.3 Removing the Pilot Assembly.**

**Note : Because this appliance is fitted with an atmosphere sensing 'Oxy-Pilot' it is not possible to replace the thermocouple separately, because the thermocouple position is factory set to a tight tolerance. Any replacement of parts on the pilot requires a complete new pilot assembly.**

- 4.3.1 Prepare work area (lay down dust sheets etc.)
- 4.3.2 Remove the trim from the product and put it in a safe location.
- 4.3.3 Remove the glass frame assembly as shown in section 3.5 and put it in a safe location.
- 4.3.4 Loosen the pilot nut and remove the two screws retaining the pilot assembly. Unscrew the thermocouple from the gas valve.
- 4.3.4 Re-assemble in reverse order and carry out a gas tightness test.

### **4.4 Replacing the Radio Frequency Receiver or its Batteries**

- 4.4.1 Prepare work area (lay down dust sheets etc.)
  - 4.4.2 Remove the trim from the product and put it in a safe location.
  - 4.4.3 The RF receiver is located on the combustion chamber base on the R/H/S of the product, below the burner assembly. Remove the RF receiver (held in position with velcro). Slide the battery cover off and replace the batteries as necessary, if replacing disconnect the wiring looms. Re-assemble in reverse order.
  - 4.4.4 Replace in reverse order and check correct operation of the appliance.
  - 4.4.5 The trim can now be re-fitted.
- NB The handset uses one LR61 (9v) and should be replaced by removing the cover on the rear of the handset.

**ENSURE THE BATTERIES ARE CONNECTED TO THE CORRECT POLARITY POSITIVE (+), NEGATIVE (-)**

## **PARTS SHORTLIST**

Replacement of any other parts must be carried out by a competent person such as a GAS SAFE registered gas installer. The part numbers of the main replaceable parts are as follows, these are available from your local Verine stockist, whose details can be found on the BFM Europe website, in the “stockist” section.

Gas Control Valve	B-92200
Ignition Lead	B-50380
Thermocouple Interrupter	B-93310
On / Off Switch & Supply Wires	B-93320
Meridian glass seal	B-139420
Meridian glass panel	CV-102111
Meridian glass frame assembly	1133-139410
Meridian base fibre centre section	B-137240
Meridian fibre right hand section	B-141710
Meridian fibre left hand section	B-141720
Meridian set bark chippings	B-142900
Meridian rear log	B-142130
Meridian complete log set	B-142120
Meridian log “B” only	B-134080
Meridian log “E” only	B-134110
Meridian log “G” only	B-134130
Meridian log “H” only	B-134140
Meridian NG ODS pilot assy	B-128100
Meridian LPG ODS pilot assy	B-128110



## SECTION FIVE - USER INSTRUCTIONS

### 5.1 Installation Information

#### Conditions of Installation

It is the law that all gas appliances are installed only by a competent (e.g. GAS SAFE) Registered Installer, in accordance with the installation instructions and the Gas Safety (Installation and Use) Regulations 1998. Failure to install appliances correctly could lead to prosecution. It is in your own interest and that of safety to comply with the law.

The fire may be fitted below a combustible shelf provided that the shelf is at least 200mm above the top of the appliance and the depth of the shelf does not exceed 150mm.

The fire may be installed below combustible shelves which exceed 150mm deep providing that the clearance above the fire is increased by 15mm for each 25mm of additional overhang in excess of 150mm.

**No purpose made additional ventilation is normally required for this appliance when installed in G.B. When installed I.E. please consult document I.S. 813 : 1996 Domestic Gas Installation which is issued by the National Standards Authority of Ireland. Any purpose made ventilation should be checked periodically to ensure that it is free from obstruction.**

If the chimney or flue has been previously used by appliances burning fuels other than gas they must be swept prior to the installation of this fire.

If this appliance is fitted directly on to a wall without the use of a fireplace or surround, soft wall coverings such as wallpaper, blown vinyl etc. could be affected by the heat and hot air and may discolour or scorch. This should be considered when installing or decorating.

The Model number of this appliance is as stated on the rating plate affixed to the control panel of the fire and the appliance is manufactured by:-

BFM Europe Ltd.  
Trentham Lakes  
Stoke on Trent  
ST4 4TJ

## About your Verine Meridian

The Verine Meridian range of log effect gas fires incorporates a unique and highly developed fuel bed which gives the realism of a loose log layout combined with realistic flames and glow. The use of durable ceramic material in the construction of the fuel-bed components ensures long and trouble free operation.

When first using the new fire a slight smell may be noticed. This is due to starch used in the manufacture of the soft ceramic logs, it is non-toxic and will soon disappear.

Please take the time to fully read these instructions as you will then be able to obtain the most effective and safe operation of your fire.

## IMPORTANT SAFETY INFORMATION

### WARNING

**This appliance has a naked flame and as with all heating appliances a fireguard should be used for the protection of children, the elderly and infirm. Fireguards should conform to B.S. 8423 : 2002 (Fireguards for use with gas heating appliances).**

It is important that this appliance is serviced at least once a year by a GAS SAFE registered gas installer and that during the service the fire is removed from the fire opening and the chimney or flue visually checked for fallen debris or blockages which must be removed. The chimney should also be checked to ensure clearance of flue products. **These are conditions of the manufacturers guarantee. After installation or during servicing a spillage test must always be carried out.**

THE FIRE MUST NOT BE OPERATED WITH THE GLASS CRACKED, BROKEN OR REMOVED. Any debris or deposits should be removed from the fuel-bed from time to time. This may be carried out by referring to the cleaning section as described later in this book.

Only the log fuel-bed must be used and only complete and genuine replacement fuel-bed logs must be sourced from BFM Europe Ltd.

The appliance must only be used with the log fuel-bed supplied and must not be used with other log fuel-beds.

Always keep furniture and combustible materials well clear of the fire and never dry clothing or items either on or near to the fire. Never use aerosols or flammable cleaning products near to the fire when it is in use.

**The ceramic fuel-bed remains hot for a considerable period after use and sufficient time should be allowed for the fire to cool before cleaning etc. The fire must only be operated with the trim and fret supplied with the fire.**

## **5.2 LIGHTING THE APPLIANCE**

- a) The control valve is positioned centrally below the burner unit of the fire when viewed from the front.
- b) To operate the appliance automatically via the remote control handset, ensure that the on / off switch is switched to the “on” position as shown below in Fig. 1

**Fig. 1**

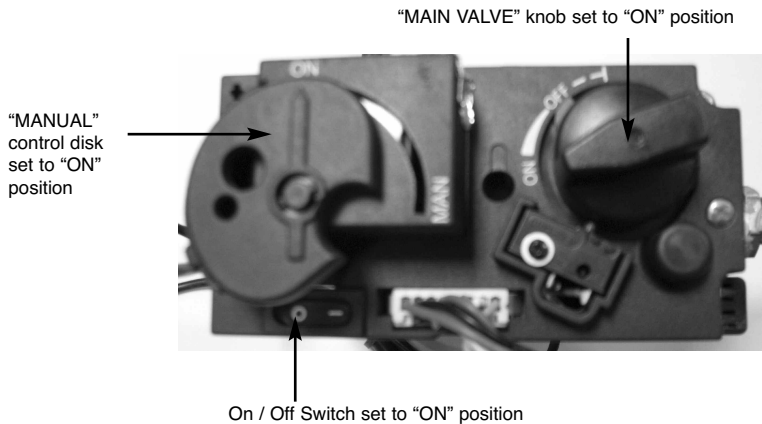

- c) Switch the MANUAL control disc to the “on” position, (as shown above in Fig. 1)
- d) Switch the main valve knob to the “ON” position. (as shown above in Fig. 1)
- e) Press and hold the “STAR” button and “UP” button on the remote handset simultaneously, see Fig. 2 overpage for image of handset.
- f) The valve will then emit an audible beep and commence its ignition sequence. When the pilot flame has been established, the control will continue to beep whilst the thermocouple heats up. When the thermocouple has reached operating temperature, it will allow gas to flow to the burner and the burner will light at high rate heat input (6.2kW NG models, 5.4kW LPG models).

- g) To reduce the heat input, press the “DOWN / STANDBY” button until the flame reduces to the low rate heat input setting (4.8kW NG models, 3.5kW LPG models). If you continue to hold the “DOWN / STANDBY” button, the burner flame will extinguish, and only the pilot flame will remain lit. If you wish to turn off the fire altogether, press the “STAR” / “OFF” button.

**AFTER THE PILOT FLAME HAS BEEN EXTINGUISHED, IF YOU WISH TO RE-LIGHT THE APPLIANCE YOU MUST WAIT AT LEAST THREE MINUTES BEFORE TRYING TO RE-LIGHT THE FIRE.**

- h) Should the handset be misplaced, you can turn the fire off by switching the “ON / OFF” switch to the “OFF” position.

**Fig. 2**

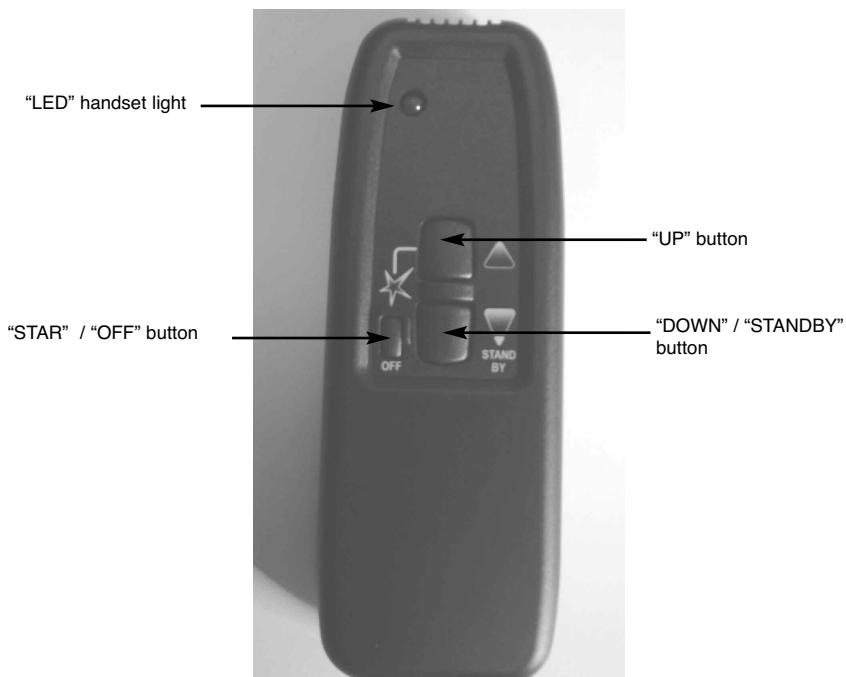

### 5.3 REMOVAL / RE-FITTING THE GLASS FRAME ASSEMBLY

- a) Remove the cosmetic trim which is held by lifting clear as shown below in Fig. 3

**Fig. 3**

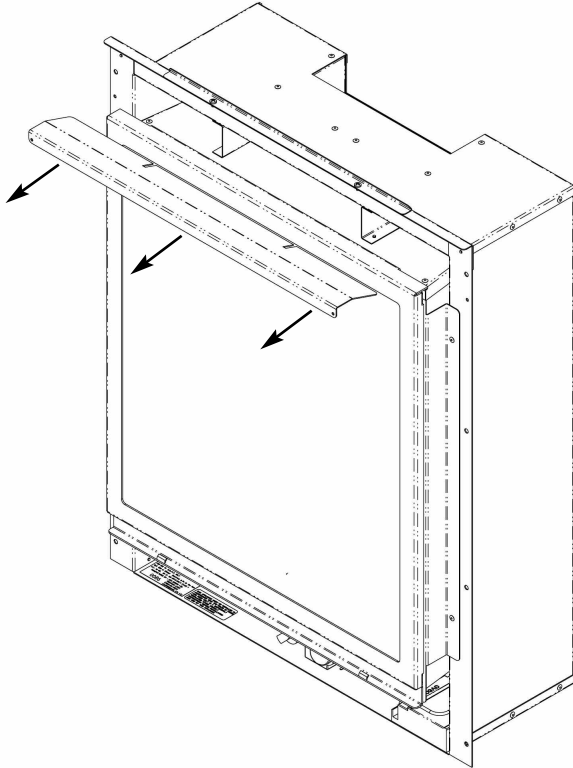

- b) Release the glass panel assembly by undoing the retaining clips at the base of the glass frame as shown below in Fig. 4

**Fig. 4**

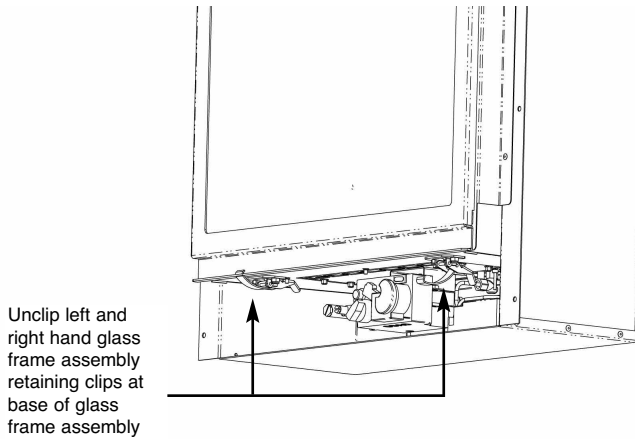

- c) Remove the glass frame assembly by tilting forwards then lifting as shown in Fig. 5 below

**Fig. 5**

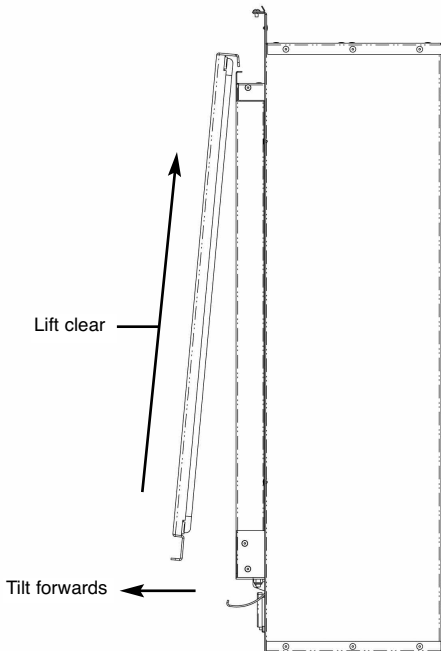

## 5.4 RE-LAYING THE FUEL-BED

- a) Place the L/H and R/H ceramic base pieces onto the ceramic support panel as shown below in Fig. 6

**Fig. 6**



- b) Place the front ceramic base piece onto the ceramic support ensuring the location tabs fit into the L/H & R/H ceramic base pieces as shown below in Fig. 7

**Fig. 7**



- c) Place the base log onto the ceramic support panel as shown below in Fig. 8, ensuring the spacer locating blocks on the rear face are fitted flush up against the rear panel.

**Fig. 8**

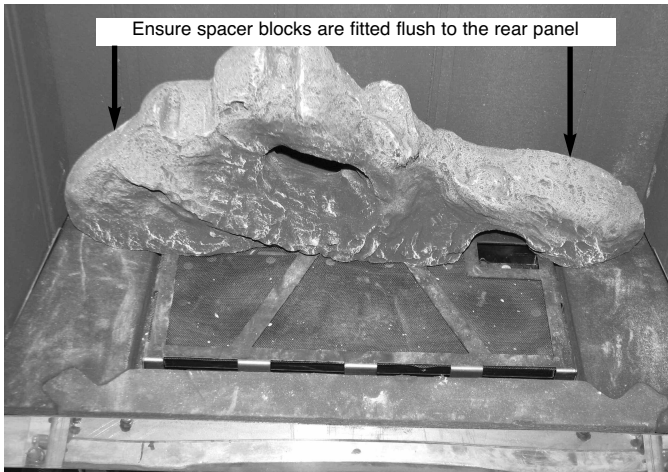

- d) Cover the burner and fuel-bed base ceramic in a single, even layer of bark chippings as shown below in Fig. 9

**Fig. 9**





- e) Position log “H” onto the base log using the location lug on the back face of log “H” and the groove on the base log to find the correct location, as shown below in Fig. 10

**Fig. 10**



- f) Position log “E” onto the base log using the location lug on the back face of log “E” and the groove on the base log to find the correct location as shown below in Fig. 11

**Fig. 11**

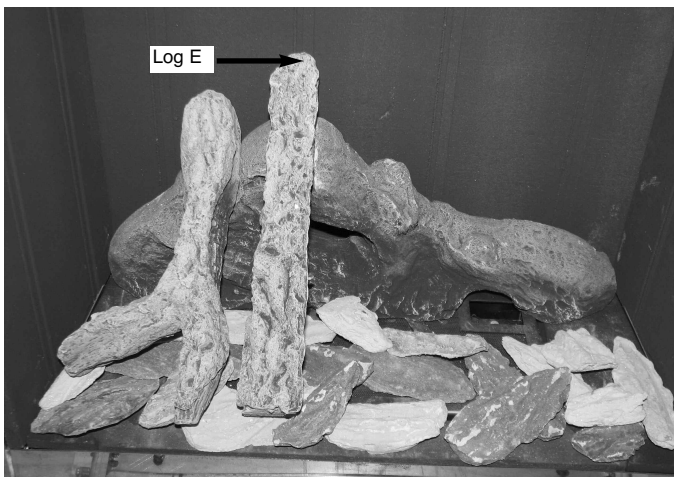

- g) Position log “B” onto the base log using the location lug on the back face of log “B” and the groove on the base log to find the correct location as shown below in Fig. 12

**Fig. 12**



- h) Position log “G” onto the base log using the location lug on the back face of log “G” and the groove on the base log to find the correct location as shown below in Fig. 13

**Fig. 13**



- i) Re-fit the glass frame assembly before proceeding to section 3.2

**Warning : Use only the log fuel-bed supplied with the fire. When replacing the log fuel-bed remove the old log fuel-bed and discard it. Fit a complete log fuel-bed from the manufacturer, only use genuine replacements.**

### **THE FOLLOWING STATEMENT IS APPLICABLE TO ALL FUEL-BED TYPES**

This appliance uses fuel effect pieces containing Refractory Ceramic Fibres (R.C.F.), which are man-made vitreous silicate fibres. Excessive exposure to these materials may cause temporary irritation to eyes, skin and respiratory tract. Consequently, it makes sense to take care when handling these articles to ensure that the release of dust is kept to a minimum. To ensure that the release of fibres from these R.C.F. articles is kept to a minimum, during installation & servicing we recommend that you use a HEPA filtered vacuum to remove any dust and soot accumulated in and around the fire, before and after working on the fire. When replacing these articles we recommend that the replaced items are not broken up, but are sealed within a heavy duty polythene bag, clearly labelled as “RCF waste”. This is not classified as “hazardous waste” and may be disposed of at a tipping site licensed for the disposal of industrial waste. Protective clothing is not required when handling these articles, but we do recommend you follow the normal hygiene rules of not smoking, eating or drinking in the work area, and always wash your hands before eating or drinking.

**This appliance does not contain any component manufactured from asbestos or asbestos related products.**

### **5.5 CLEANING - WARNING**

Before attempting any cleaning operation ensure that the fire has been allowed to fully cool. The trim is best cleaned in position on the fire when the appliance is not running and is cool. Black painted metal parts should be gently cleaned with a damp cloth.

To clean the glass panel, please remove it from the product as described on page 12. Use a clean damp cloth and ceramic glass cleaner to remove any stains or deposits from the glass panel. Do not use scouring pads as this may scratch the surface finish of the glass panel.

**PLEASE NOTE** :- The glass will require cleaning periodically. Condensation produced by the products of combustion will create marks on the inside face of the glass panel.

## CLEANING THE FUELBED

We do not recommend cleaning of the logs or fuelbed components as these are fragile and damage may result. **None of these parts must be washed or exposed to any cleaning agents or water.** Any damaged parts must be replaced by contacting your dealer or telephoning BFM Europe Ltd. on the number stated on the rear cover of this book. The log fuel-bed must only be replaced with a complete and genuine replacement item and the fire must never be run with a damaged item. The fuel-bed must be carefully fitted as stated in section 5.3.

## 5.6 REMOVAL / RE-FITTING THE TRIM

- a) The trim is secured by hooking the trim over the bracket on the top flange of the firebox as shown below in Fig. 14. The bracket is adjustable to ensure the fit is correct.

**Fig. 14**

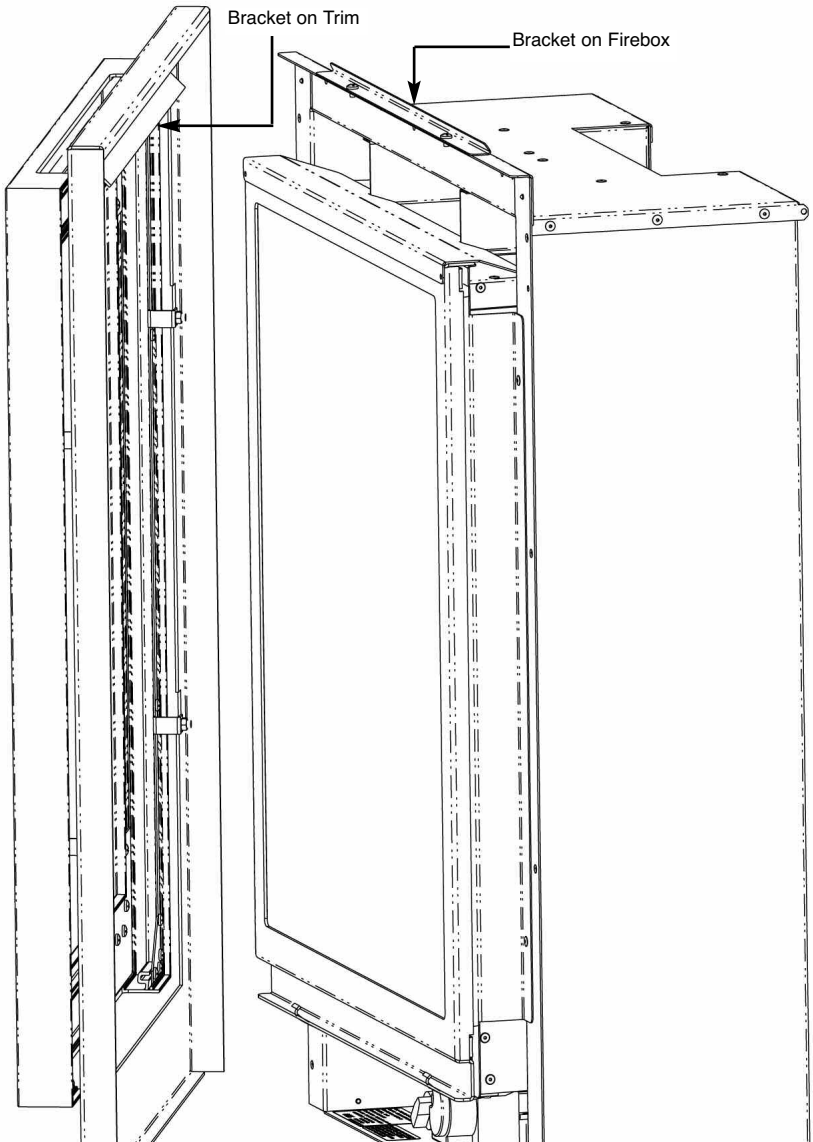

## USER REPLACEABLE PARTS

The only user replaceable parts on this fire are the fuelbed components and logs which may be replaced as described in the above section. Replacement of any other parts must be carried out by a competent person such as a GAS SAFE registered gas installer. The part numbers of the user replaceable parts are as follows, these are available from BFM Europe Ltd. who may be contacted at the number on the rear cover of this book.

Meridian base fibre centre section	B-137240
Meridian fibre right hand section	B-141710
Meridian fibre left hand section	B-141720
Meridian set bark chippings	B-142900
Meridian rear log	B-142130
Meridian complete log set	B-142120
Meridian log "B" only	B-134080
Meridian log "E" only	B-134110
Meridian log "G" only	B-134130
Meridian log "H" only	B-134140

Due to our policy of continual improvement and development the exact accuracy of descriptions and illustrations cannot be guaranteed.

Part No. B-143170  
Issue 2

VERINE  
FIRES ✦ TO ✦ INSPIRE

BFM Europe Ltd.  
Trentham Lakes  
Stoke-on-Trent  
Staffordshire  
ST4 4TJ

[www.bfm-europe.com](http://www.bfm-europe.com)

**Telephone - General Enquiries :**  
**Telephone - Service :**

**(01782) 339000**  
**(0844) 7700169**