

# Instructions for Converting Squirrel Open Flue Gas Stove (Model 551) from Natural Gas to LPG

This conversion must be in accordance with these instructions. The conversion must be undertaken by a competent person.

Before conversion, ensure that the local distribution conditions (identification of the type of gas and pressure) and the adjustment of the appliance are compatible.

## Kit No 555111 Contents

- 1 Pilot injector (Marked 27)
- 1 Burner unit including elbow injector (Cat 92 Size 160) and aeration shutter (See figure 1 for identification)
- 1 Control unit adjustment screw (Marked 0.65)
- 1 Pilot shield
- 1 Data conversion label

## Conversion Procedure

1. The appliance window is secured by a locking screw. Remove the screw with the Allen key supplied with the appliance. See figure 2. Open the window fully.
2. Detach the burner module by removing four screws. See figure 3.
3. Disconnect the burner elbow injector from the burner pipe. See figure 4.
4. Detach the burner supports from the module tray by removing five screws. See figure 5.
5. Detach the burner supports from the burner by removing two nuts. See figure 6.
6. Detach the coal locator by removing two nuts. See figure 7.
7. Detach the pilot support bracket by removing four screws. See figure 8.
8. Disconnect the pilot from the pilot pipe by undoing the pipe nut. Ease the pipe clear to get access to the pilot injector. See figure 9.

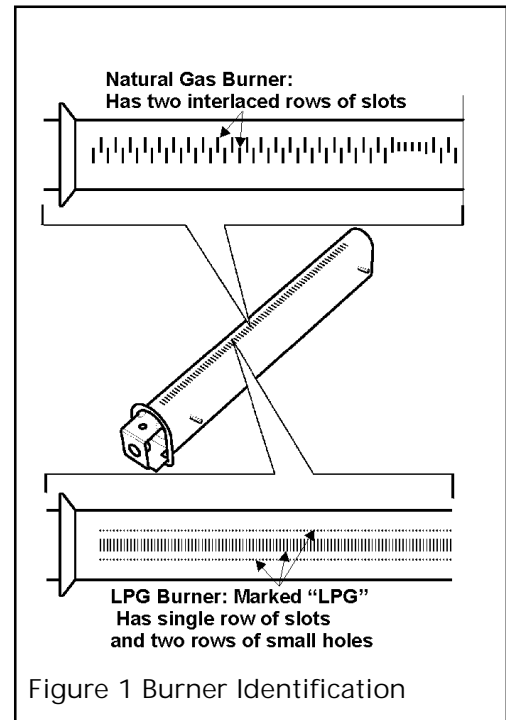

Figure 1 Burner Identification

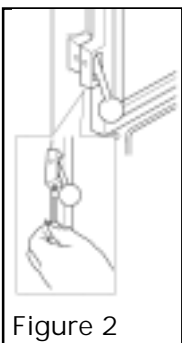

Figure 2

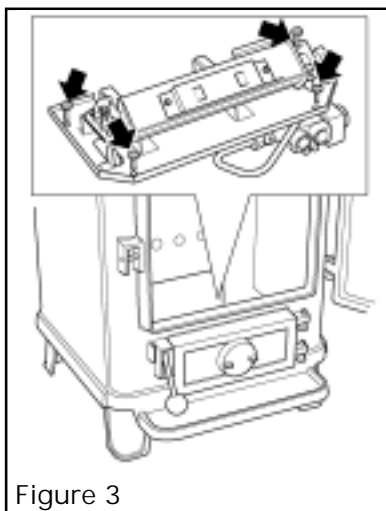

Figure 3

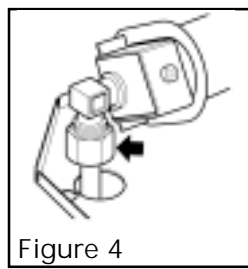

Figure 4

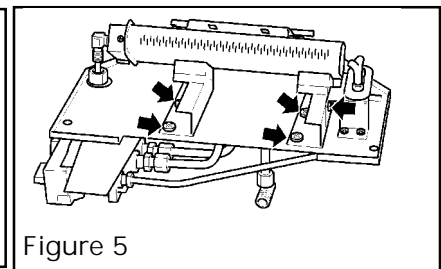

Figure 5

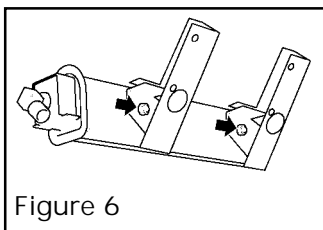

Figure 6

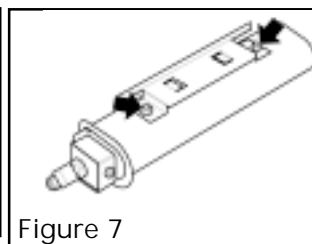

Figure 7

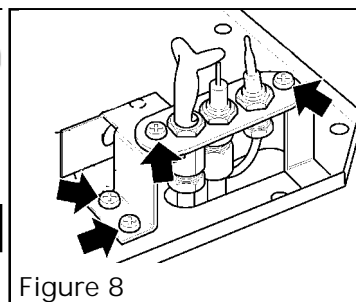

Figure 8

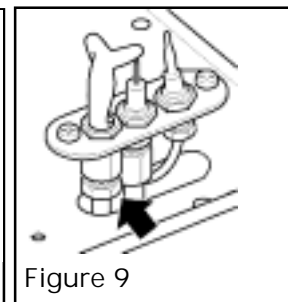
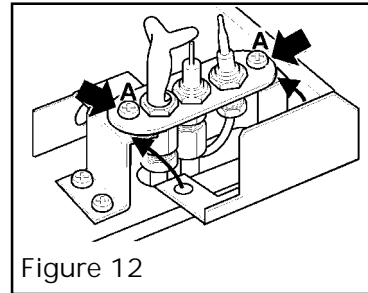
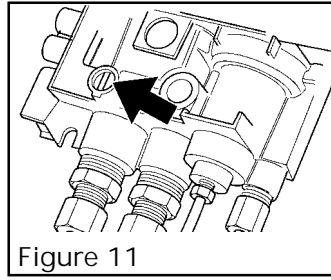
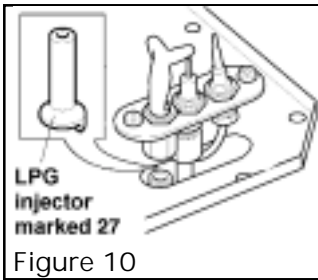

Figure 9

9. Remove the pilot injector. Replace with the LPG injector. See figure 10.
10. Remove the control unit adjustment screw. Replace with the LPG screw marked 0.65. See figure 11.
11. Refit the pilot bracket together with the additional pilot shield. The pilot shield should be located between the pilot support bracket and the pilot unit plate and secured with the two screws "A" in figure 12.
12. Reassemble the rest of the module and refit to the appliance.
13. Check the system for leaks and the setting pressure as described in the installer's guide.
14. Fit the data conversion label over the existing data label.
15. Check that the appliance operates correctly. Refer to the installer's guide.



**Important** – The air gap between the aeration collar and the burner should be set to the distance shown in figure 13. This can be done by loosening the screw on top of the collar. The collar will now slide. Once the required gap is achieved simply tighten the screw and re-check the gap.

