

INSTALLER GUIDE

LPG (PROPANE) CONVERSION KIT 0595211.

About this kit

- This conversion kit is supplied in two packs. Pack 'A' is for use with metal burners. Pack 'B' is for use with burners that have a ceramic top surface.
- Examine the burner on the gas fire and decide which pack to use.
If using pack 'A' dispose of pack 'B'.
If using pack 'B' dispose of pack 'A' and this installer guide. Pack 'B' contains a set of instructions.

Contents: -

Description	Spares Number	Quantity	Reference
Pilot injector	5108552	1	Copreci RBM 180 -02 (Stamped 225)
Injector alignment gauge	5108894	1	
Injector and carrier assembly	5108558	1	(Injector stamped 132)
Aeration plate	3003170	1	
Aeration shutter	5109806	1	
Data plate label	5108443	1	

Always turn off the gas supply and allow the appliance to cool completely before commencing any servicing. (The inlet 'T' connector for this appliance incorporates an isolating valve).

Installing the kit

Pilot injector. See figure 1.

You may note that the installer guide supplied with the gas fire states that the pilot must be replaced as a whole assembly and that its individual components are not separately replaceable. When fitting this conversion kit this can be ignored.

1. Support the pilot injector. Unscrew and remove the pilot pipe from the pilot assembly.
2. Support the pilot body. Unscrew and remove the pilot injector.
3. Fit the LPG pilot injector contained in pack 'A'.
4. Re-connect the pilot pipe.

Aeration plate and shutter

1. Remove the burner. For instructions, please refer to the 'Servicing and parts replacement' section of the installer guide supplied with the appliance.
2. Unscrew the natural gas injector.
3. Remove the shutter plate and aeration plate from the end of the burner. To do this remove the four screws (See figure 2)

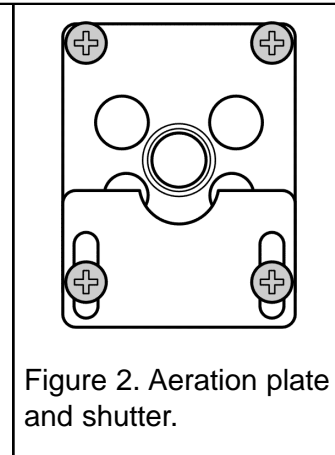
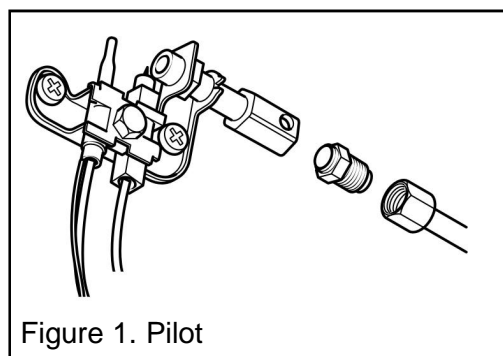

4. A replacement aeration plate and shutter are supplied in pack 'A'. Remove these from the pack and locate to the burner using the four screws removed previously (See figure 3).

Injector

1. Replace the natural gas injector with the LPG injector.

2. The kit contains an injector alignment gauge. It is important that this gauge is used to ensure that the injector is correctly aligned with the burner. Failure to check may result in poor combustion. After re-fitting the burner place the gauge into the cut out at the side of the burner tray. The slot in the gauge should surround the injector as in figure 4. If the gauge will not fit, the injector alignment will require correction. To do this, support the top of the injector and gently rotate it. Continue to rotate and check with the gauge until correct.

Data label

1. The data plate is located below the burner. The data label supplied in the kit must cover the relevant / similar information only. Peel off the backing on the LPG data label supplied in pack 'A'. Place this on top of the relevant area of the data plate.

Important: Always ensure gas soundness, sealing, spillage test and performance are satisfactory in accordance with installer guide supplied with the appliance and with current regulations.

