

VALOR FIRES

INSTALLER AND OWNER GUIDE

MODEL 846

Fitted with one of the following fascias:

CLASSICA,
INNOVA or
REGALIA

(G.C. No. EF-032-39)



This guide is intended to help you install and care for your Valor heater.

Please read thoroughly before using and keep for future reference.

However, if further information is required, our Valor Fires Technical Helpline will be pleased to help. Telephone 0844 8711 565

(National call rates apply in the United Kingdom).

In the Republic of Ireland Telephone 0044 844 8711 565.

Please keep this guide in a safe place for future reference

DON'T FORGET

To register your guarantee!

Call 0800 032 7244

Visit www.heateam.co.uk

DI501228/0606



DIMENSION

INSTALLER AND OWNER GUIDE

© Baxi Heating U.K. Limited 2008.

All rights reserved. No part of this publication may be reproduced in any material form (including photocopying), stored in any medium by electronic means (including in any retrieval system or database) or transmitted, in any form or by any means, whether electronic, mechanical, recording or otherwise, without the prior written permission of the copyright owner.

Applications for the copyright owner's permission to reproduce any part of this publication should be made, giving details of the proposed use, to the following address: The Company Secretary, Baxi Heating UK Limited, The Wyvern Business Park, Stanier Way, Derby, DE21 6BF.

Warning: Any person who does any unauthorised act in relation to a copyright work may be liable to criminal prosecution and civil claims for damages.

VALOR FIRES

Valor Fires, Erdington, Birmingham B24 9QP.
www.firesandstoves.co.uk

Because our policy is one of constant development and improvement, details may vary slightly from those given in this publication

INSTALLER AND OWNER GUIDE

Safety First.

Valor Fires heaters are CE Approved and designed to meet the appropriate British Standards and Safety Marks.



Quality and Excellence.

All Valor Fires heaters are manufactured to the highest standards of quality and excellence and are manufactured under a BS EN ISO 9001 quality system accepted by the British Standards Institute.



CUSTOMER CARE

Thank you for choosing Valor Fires

All Valor Fires heaters are designed to meet the most stringent quality, performance and safety requirements to provide our customers with many years of trouble free service. This guide aims to improve your understanding and appreciation of your new Valor Fires heater, by providing simple and informative instructions to enable you to install it and to ensure that you benefit from the excellent performance and features it has to offer.

If you require further assistance, the **Valor Fires Technical Helpline** will be pleased to help.

Please telephone **0844 8711 565** (local rates apply in the United Kingdom). In the Republic of Ireland please telephone **0044 844 8711 565**.

INSTALLER AND OWNER GUIDE

1. HANDLING AND UNPACKING

Before continuing any further with the installation of this heater please read the following:

Important instructions.

- A carry handle is fitted to the top of the heater. We recommend that this is used when moving the heater.
- The approximate lifting weights (kg) of the heater parts are listed below: -

<u>Model</u>	<u>Heat engine</u>	<u>Fascia</u>	<u>Spacer</u>
Classica	8.21	9.73	1.0*
Innova	8.21	7.88	1.0*
Regalia	8.21	5.40	N/A**

* Although the heater is supplied with a spacer frame, an optional spacer frame kit is obtainable either from your heater supplier or direct from Valor Fires Sales. The kit is a 71mm spacer kit (Kit number 0584081). This spacer when added to the one supplied with the heater enables the heater to be flat wall fixed.

** The Regalia model is not intended for wall mounting or installations requiring the use of a spacer frame.

- One person should be sufficient to lift the heater. If for any reason this weight is considered too heavy then obtain assistance.
- When lifting always keep your back straight. Bend your legs and not your back.
- Avoid twisting at the waist. It is better to reposition your feet.
- Avoid upper body / top heavy bending. Always bend from the knees rather than the waist. Do not lean forward or sideways whilst handling the heater.
- Always grip with the palm of the hand. Do not use the tips of fingers for support.
- Always keep the heater as close to the body as possible. This will minimise the cantilever action.
- Use gloves to provide additional grip.
- Always use assistance if required.

2. SAFETY

This appliance is not intended for use by persons (including children) with reduced physical, sensory or mental capabilities, or lack of experience and knowledge, unless they have been given supervision or instruction concerning use of the appliance by a person responsible for their safety.

INSTALLER AND OWNER GUIDE

Always

- **Always** install the heater in accordance with this guide. If in doubt obtain expert advice.
- **Always** make sure the electrical socket is accessible and located adjacent to, but not above or behind the heater.
- **Always** disconnect the heater from the electrical supply before carrying out cleaning or maintenance.
- **Always** use a fireguard when young children and infirm persons can come into contact with the heater.
- **Always** use genuine Valor Fires spares.

Never

- **Never** leave children unsupervised in a room where the heater is ON and unguarded.
- **Never** obstruct or cover the fan outlet or force items into heater openings.
- **Never** install or use the heater anywhere where water is in use, i.e. Bathrooms, Kitchens, Shower Rooms and Swimming Pools etc.
- **Never** use aerosols or steam cleaners on or around the heater.
- **Never** route the electric cable under carpet etc.
- **Never** install the heater close to curtains or combustible materials.
- **Never** use the heater to dry clothes etc.
- **Never** sit or stand on the heater.
- **Never** use the heater with a timer switch or similar device.

Important Electrical Safety

The heater must **not** be located in front of or under an electrical socket, the socket must always be accessible in order to disconnect the heater from the electrical supply for maintenance and cleaning.

CAUTION: In order to avoid a hazard due to inadvertent resetting of the thermal cut out, this appliance must **not** be supplied through an external switching device, such as a timer, or connected to a circuit that is regularly switched on and off by the utility.

Important! This heater must be earthed.



- The heater is supplied with a 3 pin 13 Amp fused re-wireable plug with 1mm² 3 core cable.
- The wires in the cable are coloured in accordance with the following code:-
Live = Brown
Neutral = Blue
Earth = Green /Yellow
- The electric supply must be safely routed from the heater to an electrical socket. If the electric cable is damaged, to avoid a hazard it must be replaced by a Valor Fires authorised service agent, or similarly qualified person. All external wiring between the heater and the electrical supply shall comply with current IEE regulations. Extension leads should not be used.

INSTALLER AND OWNER GUIDE

3. OPTIONAL KITS

The following kits are obtainable either from your heater supplier or direct from Valor Fires Sales.

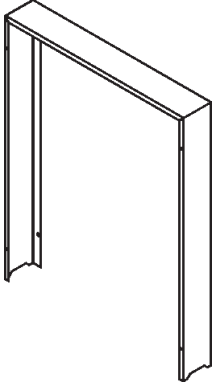
Spacer frame kit 0584081 (This kit is not applicable for the Regalia model).

Contents	Quantity	(Illustrations are not to scale)
Spacer frame	1	
No 8 x 3/8 Self-tapping screws	4	

Elevated installation kit 0584091 (This kit is not applicable for the Regalia model).

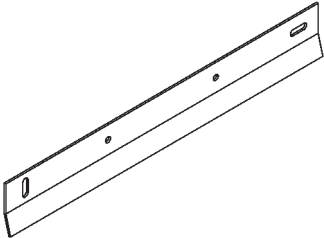
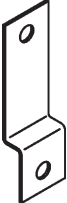
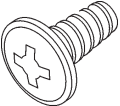
Contents	Quantity	(Illustrations are not to scale)
Wall mounting bracket	2	
Lower securing bracket	1	
No.8 x 5/16 Pan head pozi screws	5	

4. FITTING THE HEATER

Please read this section thoroughly before positioning the heater.

Do I need any tools?

Depending upon the chosen method of installation you may need the following tools: -

- For Spacer frame or screw fixed installations you will need **A Pozidrive / Phillips / cross head screwdriver**. This should have a number 2 size tip.
- If wire fixing and drilling into brickwork you will need a power drill (preferably with hammer action) and appropriate size drill bit for the wall plugs supplied.

Where and how can you fit the heater?

Q Can the heater be installed into a 'hole in the wall' (elevated opening)?

A The heater is suitable for 'hole in the wall' installations; these being installations where the heater is recessed into a builders opening. This is **not** referring to the heater being hung on the wall. It is important that the electrical socket is accessible and located adjacent to, but not above or behind the heater. (The Classica and Regalia fascias have been designed for traditional installations where the base of the fascia sits on a hearth or similar surface. For this reason we recommend that a plinth be fitted under the heater).

Q Do you want to fit the heater into a surround or fireplace opening without the spacer frame?

A The minimum rebate / depth required is 145mm.

Q What opening size do you need in the surround or fireplace opening?

A This heater can be fitted into fireplaces or surrounds where the following dimensions are available.

Width	395mm - 450 mm
Height	555mm - 590 mm
Depth	At least 145mm

Q Do you want to fit the heater into a surround using the spacer frame supplied with the heater?

A The minimum rebate required is 71mm. This method is not applicable on the Regalia model.

Q Do you want to fit the heater against a flat wall with the base of the heater on a hearth or similar surface?

A You will need to purchase the optional spacer frame kit (kit number 0584081). This spacer when added to the one supplied with the heater enables the heater

INSTALLER AND OWNER GUIDE

to be flat wall fixed. The depth of the combined spacer frames is 145mm. This method is not applicable on the Regalia model.

Q Do you want to wall mount the heater against a flat wall?

A You will need to purchase the **Optional spacer frame kit** (kit number 0584081) and an **Elevated installation kit** (kit number 0584091). The optional spacer when added to the one supplied with the heater covers the full depth of the heater rear (145mm). This method is not applicable on the Regalia model.

General notes to read before fitting your heater.

There should be at least 50mm clearance between the top of the fascia and anything such as a shelf, fireplace surround or mantel etc. This will allow the fascia to be lifted off or removed during servicing. To check the shelf clearance gently place the fascia against the surface to which it is to be fixed and measure the distance from the top of the fascia.

If fitting the heater onto a reflective or shiny surface such as a hearth we recommend that this surface does not extend further than 300mm from the fixing plane (wall). Reflective or shiny surfaces that project further than 300mm may reflect an image of the internal light source.

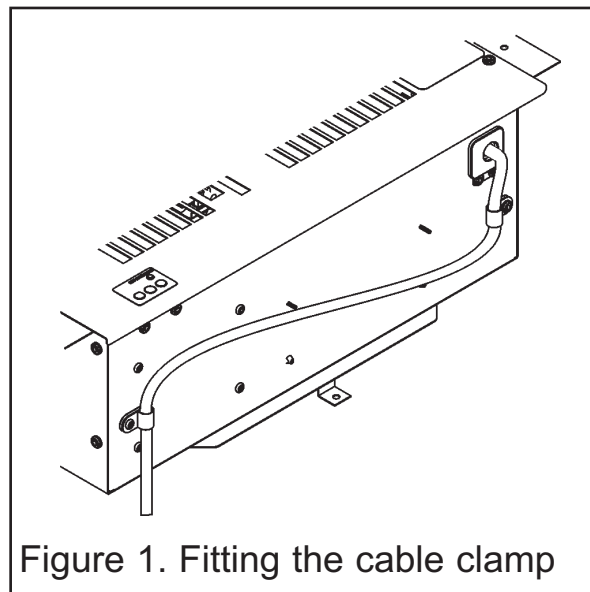

Figure 1. Fitting the cable clamp

Fitting the cable clamp.

If the mains cable is to be routed to the left hand side of the heater there is a cable clamp supplied with the heater to hold the cable in place. This prevents the cable being trapped under the heater during installation. Fit the cable clamp as in figure 1.

Fitting the batteries to the Remote Control Handset.

The remote control handset uses 2 x 1.5V AAA type batteries. For longer battery life use only alkaline batteries. To install the batteries, slide the cover down on the rear of the handset and remove (See figure 2). The polarity of the batteries is marked on the inside of the battery compartment.

If the heater does not respond to the remote control handset commands, it is likely that the batteries are faulty or require replacement.

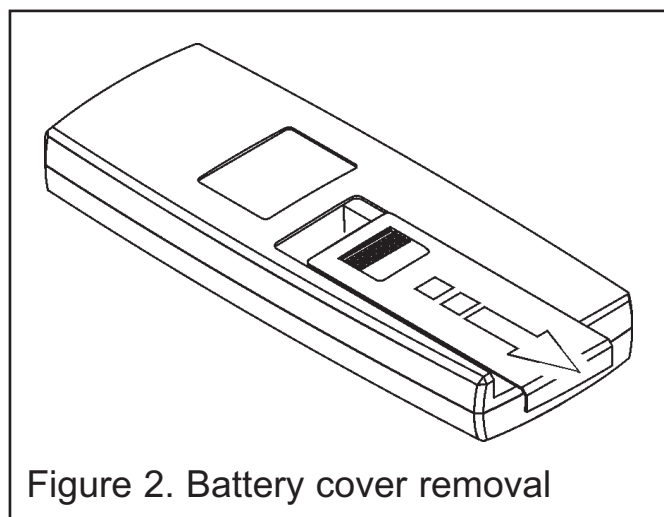

Figure 2. Battery cover removal

INSTALLER AND OWNER GUIDE

Securing the heater.

The contents have been identified in figure 3 (Fascias are not included).







Contents	Quantity	(Illustrations are not to scale)
Heater	1	
Spacer frame (Not included with Regalia model)	1	
No. 8 x 3/8 pan head screw	5	
Tension wire	1	
Screweye	1	
Wood screw	5	
Wall plug	5	
'AAA' Battery	2	
Cable clamp	1	
Handset	1	

Figure 3. Contents

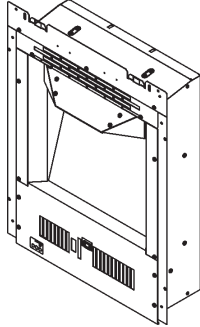
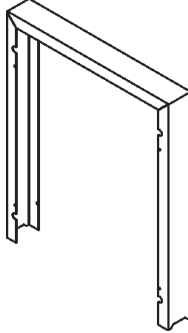
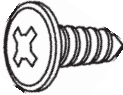
INSTALLER AND OWNER GUIDE

The heater must be secured into position to prevent it from being tipped over. The following securing options are available:

- **Method A** - Securing the heater with **Screws**.
- **Method B** - Securing the heater with **Wire**.
- **Method C** - Securing the heater using the **Spacer Frame** supplied with the heater (Not applicable on Regalia model).
- **Method D** - Securing the heater using the **Optional Spacer Frame** (kit number 0584081) (Not applicable on Regalia model).
- **Method E** - Securing the heater in an elevated position using the **Optional Spacer Frame kit** (kit number 0584081) and the **Elevated Installation kit** (kit number 0584091) (Not applicable on Regalia model).

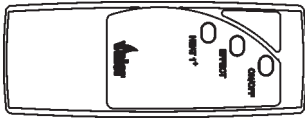
(The Classica fascia has been designed for traditional installations where the base of the fascia sits on a hearth or similar surface. For this reason we do not recommend the Classica model for wall mounting).

If fitting the heater into a fireplace or surround opening, try the heater in the opening to ensure that it will fit.

If fitting the heater onto a decorative hearth surface such as marble or tile it is advisable to protect the hearth surface. Do not drag the heater as the surface finish may be damaged.

Method A - Securing with screws.

Note - If fixing to marble it is recommended that Method B - 'Securing with wire' is used. Drilling marble without the correct tools and experience may result in the marble cracking.

1. Place the heater into the fireplace or surround opening. Make sure that the heater is in the middle of the surround or fireplace.
2. There are two slotted holes in the top of the heater and four holes in the side flanges (See figure 4). We recommend the use of two upper holes and two lower holes. Mark through the required holes so that their position is clear when the heater is removed.
3. Remove the heater.
4. Drill an appropriate size hole in each of the marked positions for the wall plugs supplied. Insert wall plugs into the drilled holes.
5. Place the heater so that the holes are in line with the wall plugs in the fixing surface.
6. Screw and secure the heater with four wood screws - (See figure 3 and 4).

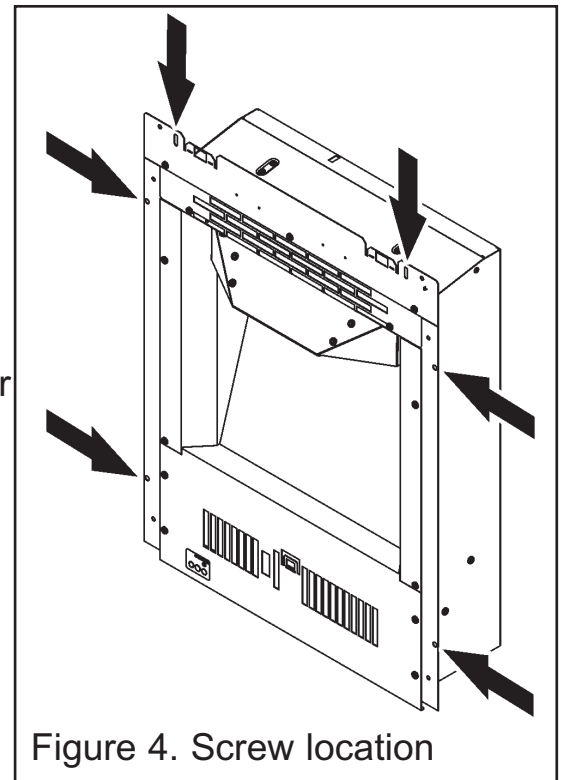

Figure 4. Screw location

INSTALLER AND OWNER GUIDE

Method B - Securing with wire.

This method of securing is recommended where the wall / brickwork is in poor condition or where marble back panels / surrounds are used.

Although this section deals with fireplace openings without a spacer, this method of securing the heater can also be used with the spacer frame supplied with the heater (See point 7 and figure 8 of method C). It can also be used with the optional spacer frame (See point 7 and figure 9 of method D).

1. The fixing kit supplied with the heater includes a steel wire and eyescrew. These can be used to secure the heater to the back of a surround / fireplace opening.
2. Mark the eyescrew position on the centre line at the back of the fireplace opening and at a height of 565-575mm (See figure 5).

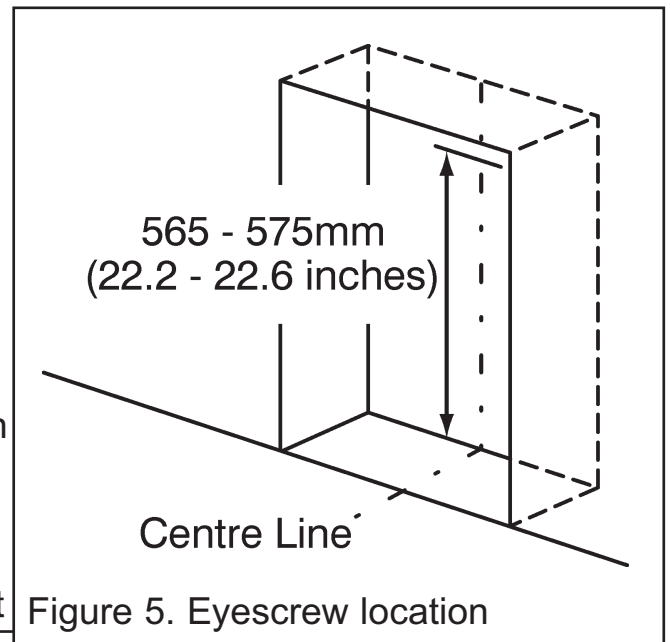

Figure 5. Eyescrew location

3. Drill an appropriate size hole in the marked position.
4. Insert a wall plug into the drilled hole.
5. Screw the eyescrew into the wall plug.
6. Position the heater in front of the fireplace opening.
7. At the top of the heater there are four small holes, two each side of the heater. From the front of the heater, thread about 50mm of the steel wire into the

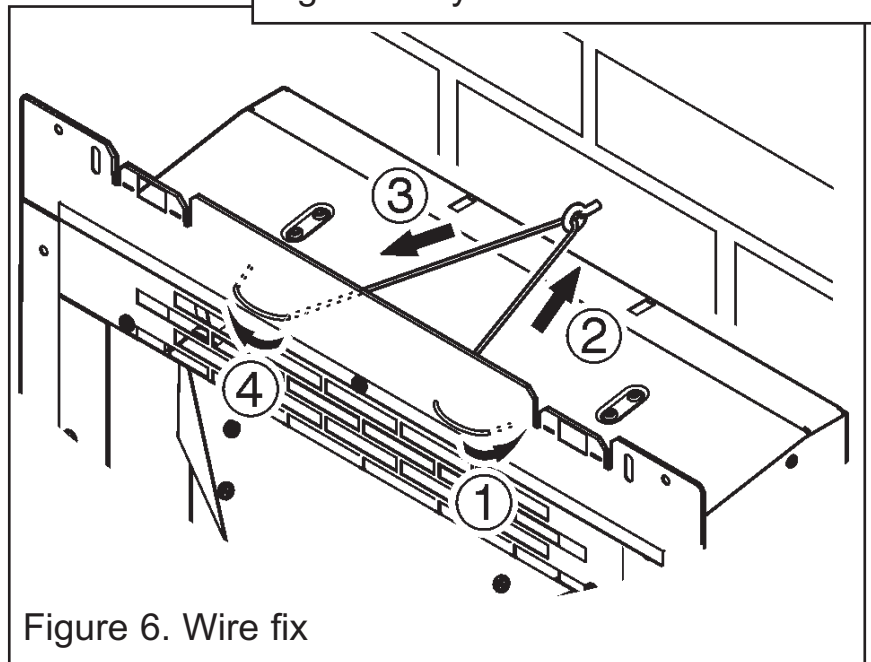

Figure 6. Wire fix

- outside small hole on the right side of the heater (See point 1 - figure 6).
8. Thread the other end of the wire through the remaining small hole to the left. Continue to push the wire through this hole until there is only a small loop of wire at the front of the heater (See point 2 - figure 6).
9. At the back of the heater there will be a long piece and a short piece of wire coming through the two holes. Hold the short piece and give the long piece a gentle tug. This will secure the steel wire. Take the long piece and thread this through the eyescrew in the back of the fireplace opening (See figure 6).
10. From the back of the heater thread the long piece of steel wire through the inner small hole on the left hand side of the heater (See figure 6).

INSTALLER AND OWNER GUIDE

11. Locate the heater in the fireplace opening, then from the front of the heater, gently pull the steel wire on the right hand side to gather up the excess until the heater is secure. Thread the wire through the remaining small hole to lock the wire and heater in place (See point 4 - figure 6).

Method C - Securing with the Spacer Frame supplied with the heater.

The spacer frame is for use in installations where the chimney recess or rebate in the surround / mantle is not deep enough to take the full depth of the heater. The minimum rebate / depth required is 71mm.

For your safety the frame and heater must be securely fixed to the rear wall.

The rear of the spacer has two screw location slots in the top flange. These should be to the rear when fitting.

1. Position the spacer frame against the wall. Ensure that the spacer frame is central to the fireplace.

2. The top rear flange of the spacer frame has two screw locations. Mark the positions of the two screw locations on the rear wall (See figure 7).

3. Remove the spacer frame from the fireplace and place away from the work area.

4. Drill the locations using a suitably sized masonry drill bit for the wall plugs supplied.

5. Insert two wall plugs provided into the holes.

6. Insert a wood screw into each hole (See figure 3) and screw in until there is approximately 6mm of screw protruding from the wall.

7. Secure the spacer frame to the heater using four No.8 x 3/8 screws supplied (See figures 8 and 3).

8. Carefully lift the heater and locate the slots on the rear of the spacer frame onto the screws in the wall. The screws can be adjusted to ensure a tight fit. When mounting to decorative surfaces such as wallpaper care should be taken not to drag the heater down the wall as this may damage the decorative surface.

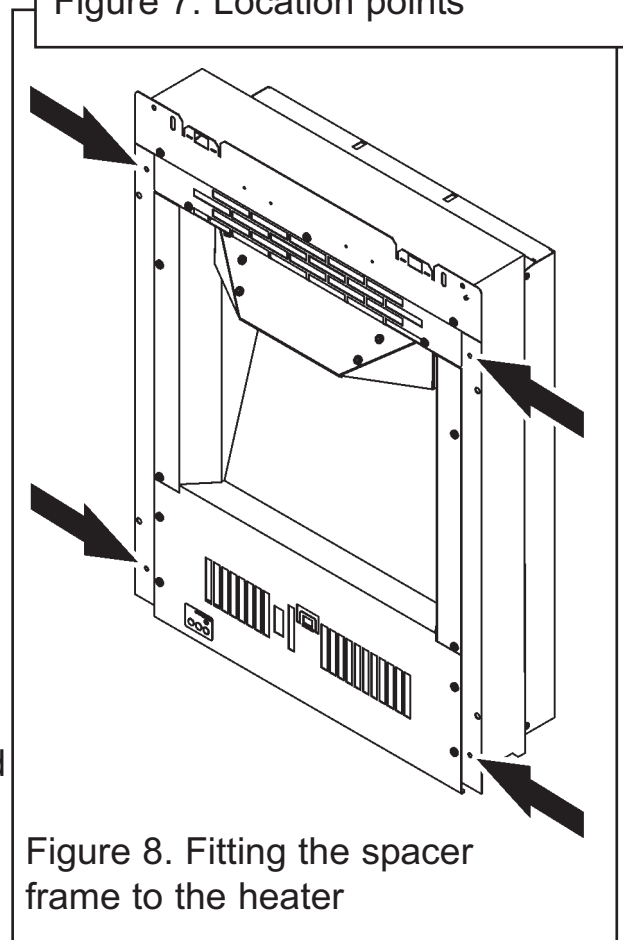
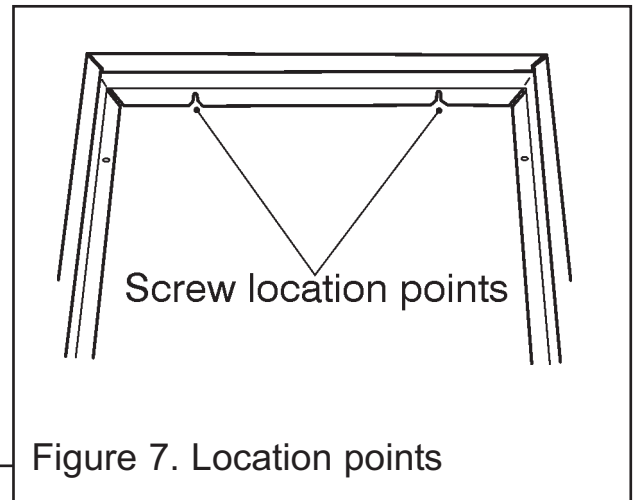

INSTALLER AND OWNER GUIDE

Method D - Securing with the optional spacer frame supplied in kit 0584081.

The optional spacer is for use where a flat wall installation is required (Not applicable on Regalia model).

1. There are four screws supplied with the optional spacer frame. The narrow flange of the optional spacer should be placed against the spacer supplied with the heater. Screw the optional spacer frame to the one supplied with the heater (See figure 9).

Note: The optional spacer is smaller than the one supplied with the heater.

2. The top rear flange of the spacer frames has two screw locations. Mark the positions of the two screw locations on the rear wall (See figure 7- This only shows one spacer).

3. Remove the spacer frames from the fireplace and place away from the work area.

4. Drill the screw locations using a suitably sized masonry drill bit for the wall plugs supplied.

5. Insert two wall plugs provided into the holes.

6. Insert a wood screw into each hole (See figure 3) and screw in until there is approximately 6mm of screw protruding from the wall.

7. Secure the spacer frames to the heater using four No.8 x 3/8 screws supplied (See figures 9 and 3).

8. Carefully lift the heater and locate the slots on the rear of the spacer frame onto the screws in the wall. The screws can be adjusted to ensure a tight fit. When mounting to decorative surfaces such as wallpaper be careful not to drag the heater down the wall as this may damage the decorative surface.

Step 1

Screw the optional spacer to the spacer supplied with the heater.

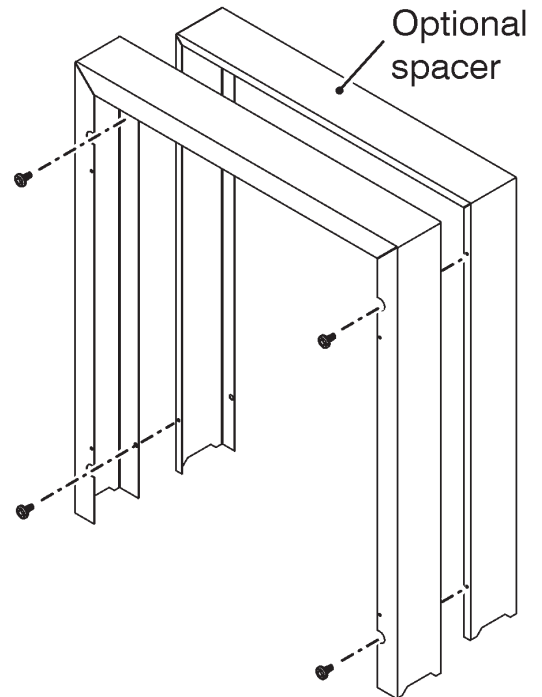

Step 7

Screw the spacers to the heater.

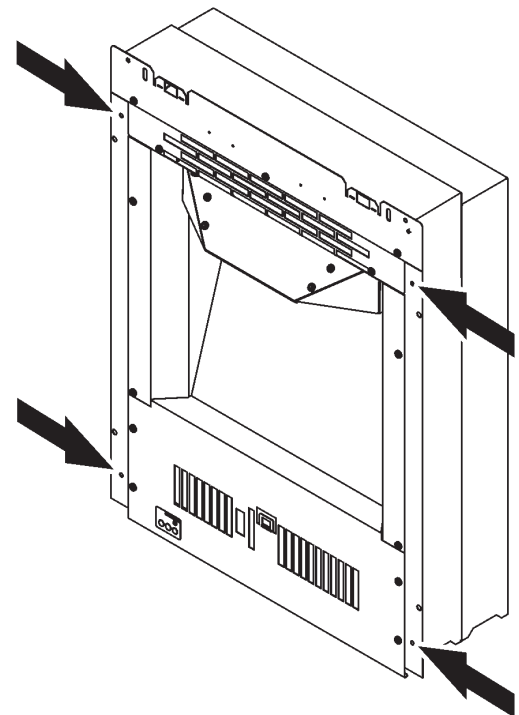

Figure 9. Fitting the optional spacer frame to the heater

INSTALLER AND OWNER GUIDE

Method E - Wall mounting with the optional spacer frame kit (0584081) and Elevated Installation kit supplied in kit (0584091).

The Optional Spacer Frame and Elevated Installation kit are required where a wall mounted installation is required (Not applicable on Regalia model).

(The Classica fascia has been designed for traditional installations where the base of the fascia sits on a hearth or similar surface. For this reason we do not recommend the Classica model for wall mounting).

Fitting a wall mounting bracket to the wall.

When wall mounting your heater we recommend that the heater be mounted no more than 240mm from the floor. To achieve this, the hole centres in the wall mounting bracket must be no more than 700mm from the floor (See figure 10). Mounting the heater above this may affect the visual appearance of the fuel effect.

If fitting to a conventional brick wall then use the outer slotted holes in the bracket. If fitting to a plasterboard wall that has a wooden frame behind it then use all four fixing holes in the bracket. This is required to spread the load. If the wall plugs supplied are not satisfactory, purpose made plasterboard fixings can be purchased from DIY outlets.

1. Mark the positions of the hanging bracket holes on the wall. We recommend the use of a spirit level to ensure that the bracket is level.
2. Drill the marked positions using a suitable sized masonry drill bit for the wall plugs supplied.
3. Insert the wall plugs and secure the bracket to the wall using wood screws (See figure 3).

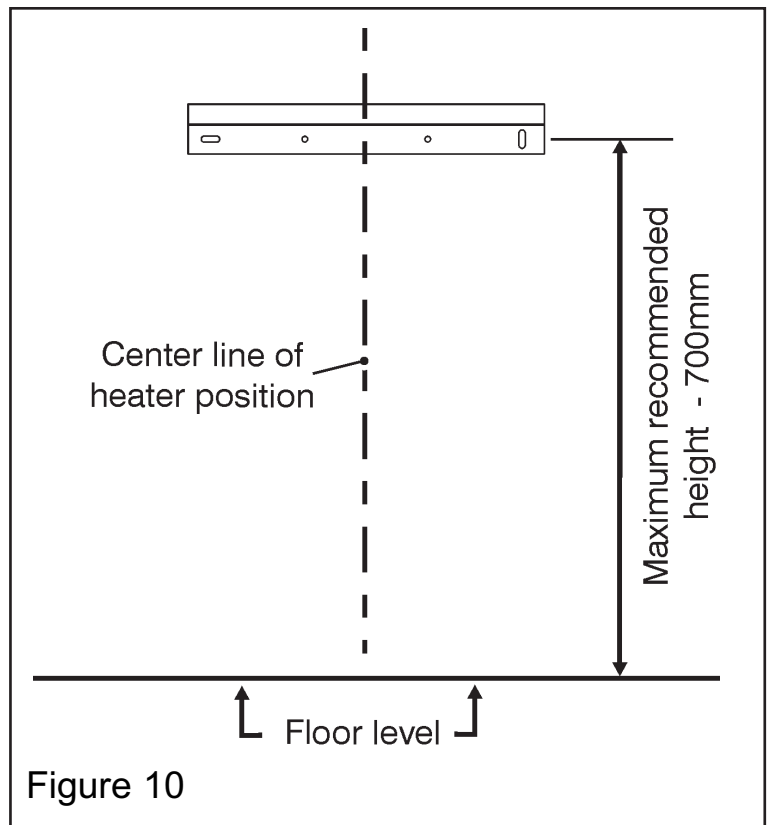

INSTALLER AND OWNER GUIDE

Fitting the brackets to the heater.

1. Secure the spacer frames to the heater as in steps 1 and 7 of METHOD D (See figure 9).

2. The Elevated Installation kit contains two wall mounting brackets and one lower bracket. Secure one of the wall mounting brackets to the rear of the heater using two of the No.8 x 3/8 screws supplied. Ensure that the bracket is correctly orientated before securing (See figure 11).

3. Secure the lower bracket to the rear of the heater using one of the No.8 x 3/8 screws supplied (See figure 12).

4. Hang the heater body on the wall hanging bracket.

5. Underneath the heater, mark on the wall the position of the hole in the lower support bracket.

6. Lift the heater off the wall.

7. Drill the marked position using a suitable sized masonry drill bit for the wall plugs supplied.

8. Insert the wall plug.

9. Hang the heater body on the wall hanging bracket. Secure the bottom of the heater using a wood screw (See figure 3).

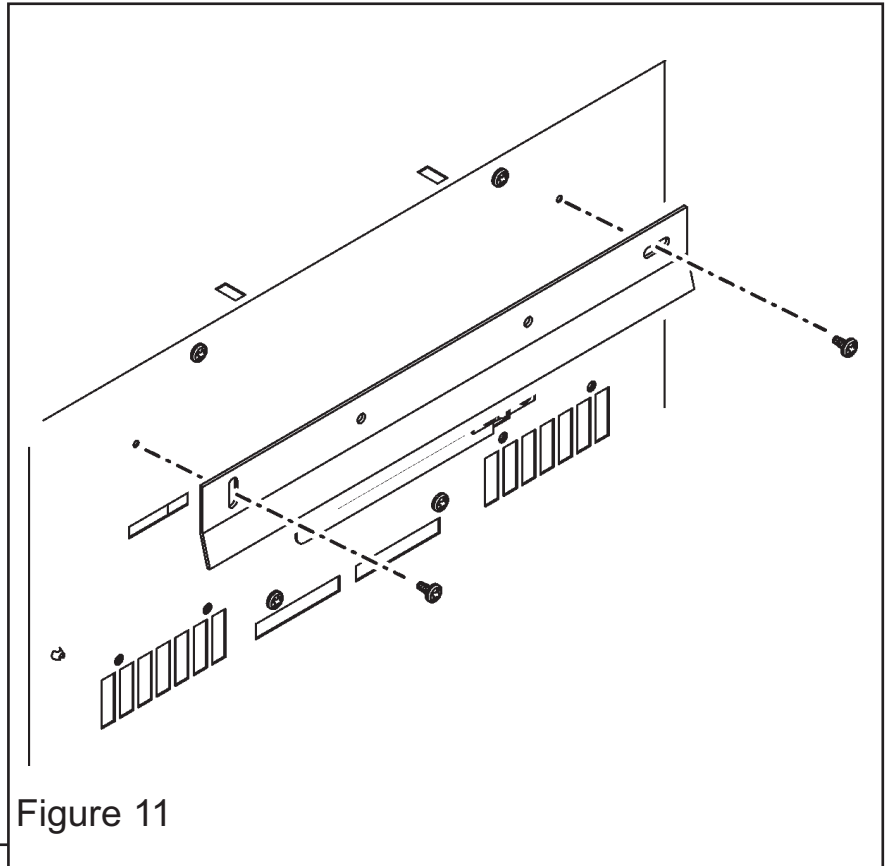

Figure 11

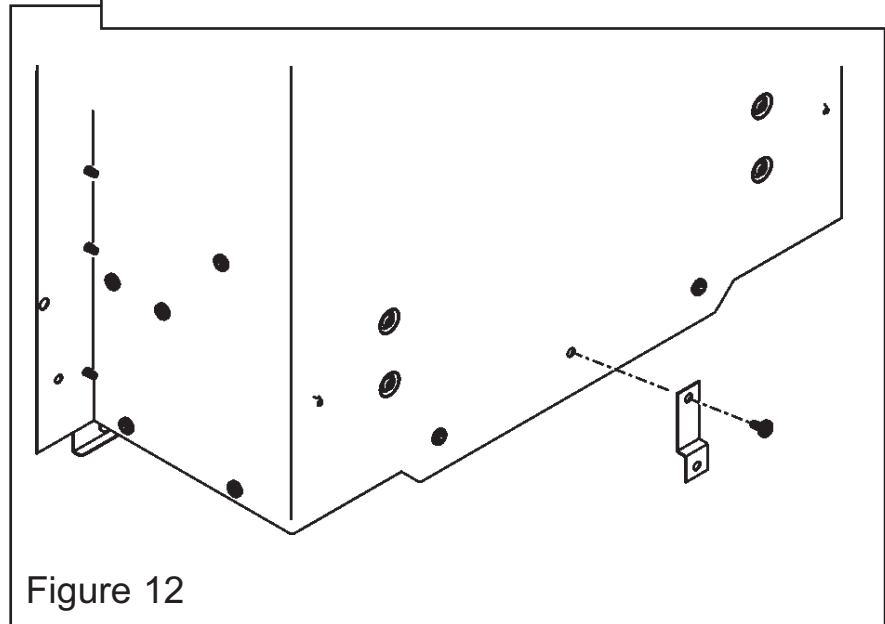

Figure 12

5. FITTING THE FASCIA

Fitting the Classica fascia.

1. Remove the fascia from its packaging.
2. There are two magnets on the lower raised areas of the fascia (See figure 13). Ensure that they are located correctly before fitting the fascia.
3. Supplied with the fascia is a black decorative moulding. Remove the two screws from the rear of the fascia (See figure 13), locate the moulding and secure using the two screws removed previously.
4. Hold the fascia firmly and lift into place. Keeping the magnets away from the body of the heater, locate the fascia hanging brackets into those on top of the heater (See figure 13). Lower the fascia into place and swing the bottom of the fascia towards the heater to engage the magnets.

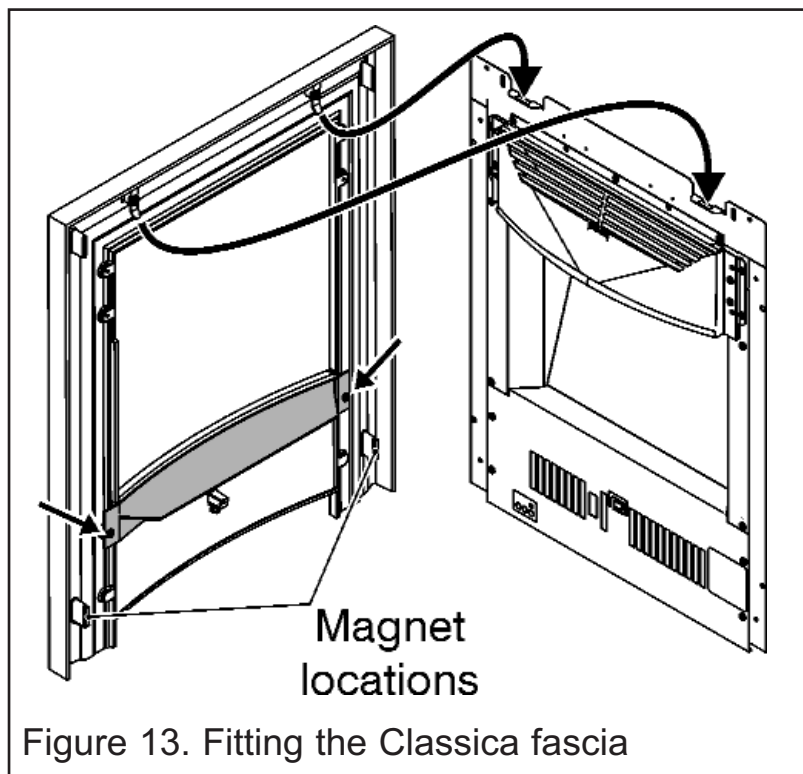

Figure 13. Fitting the Classica fascia

Fitting the Regalia fascia.

1. Remove the fascia from its packaging.
2. Supplied with the fascia is a black decorative moulding. Remove the two screws from the rear of the fascia (See figure 14), locate the moulding and secure using the two screws removed previously.
3. Hold the fascia firmly and lift into place. Locate the fascia hanging brackets into those on top of the heater (See figure 14). Lower the fascia into place and swing the bottom of the fascia towards the heater.

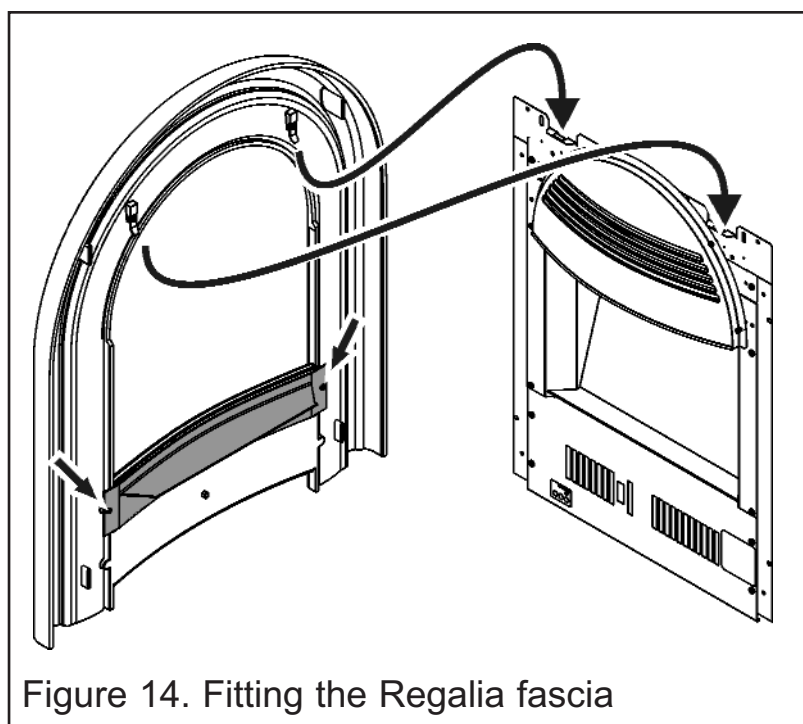

Figure 14. Fitting the Regalia fascia

INSTALLER AND OWNER GUIDE

Fitting the Innova fascia.

If fitting the Innova into an elevated position please see the next section on page 17.

1. Remove the fascia from its packaging.
2. There are two magnets on the lower rear of the fascia. They should rest against the outer edge of the two raised sections (See figure 15). Ensure that they are located correctly before fitting the fascia.
3. Hold the fascia firmly and lift into place. Keeping the magnets away from the body of the heater, locate the fascia hanging brackets into those on top of the heater (See figure 15). Lower the fascia into place and swing the bottom of the fascia towards the heater to engage the magnets.

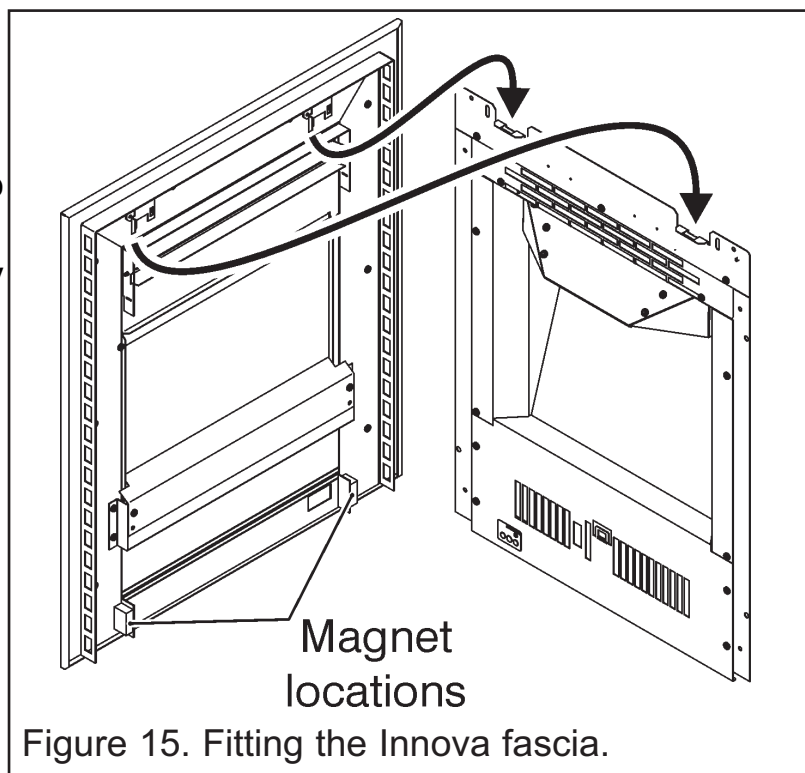

Fitting the Innova baffle.

When fitting the Innova into an **elevated position** there is baffle supplied with the Elevated Installation kit. This baffle will improve the flame effect in elevated positions. Although supplied in the kit, a baffle may have already been fitted to the rear of the Innova fascia; if so, ignore this section.

1. Lay the fascia face down on a flat surface.
2. Secure the baffle to the rear of the fascia as in figure 16 using the two No.8 x 5/16 screws supplied.

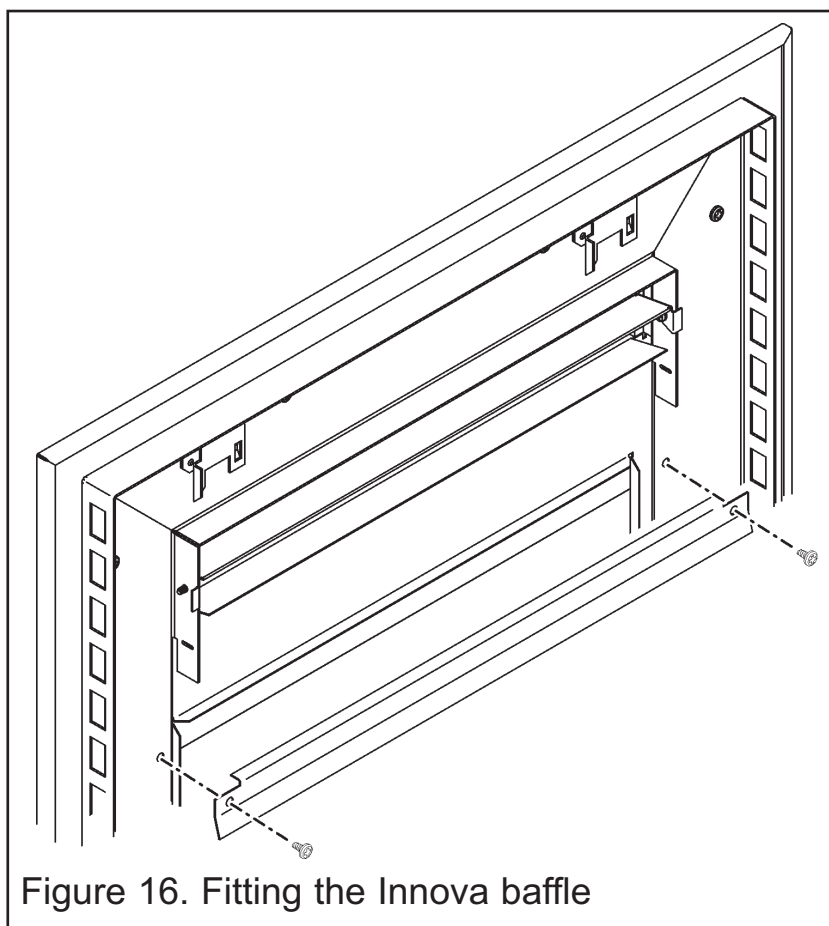

6. OPERATING THE HEATER

Never cover the heater or obstruct the opening at the base of the heater, this could cause overheating and consequent risk of fire.

The appliance can be controlled by the manual control located on the lower left hand side of the heater or by using the remote control handset.

How does the heating element operate?

The heating element on the heater has a fixed 2kW output, and is controlled by an electronic thermostat. The heating element operates to reach a preset temperature, which when achieved, will result in the heating element and heater fan switching off. When the thermostat detects a temperature below the preset temperature, the heater fan and heating element will switch on automatically, according to room temperature and chosen thermostat setting. The heater fan and element will therefore cycle off and on during normal operation.

Remote Control - What do the buttons do?

Pressing the red 'ON/OFF' button.

To activate the remote handset it is necessary to press the red ON/OFF button. The status lamp on the heater will turn green - see illustration on page 19).

Pressing the 'EFFECT' button.

This turns the DIMENSION effect on and turns the status lamp amber. Press the button again to turn the DIMENSION effect off.

Pressing the Heat⁺ button.

This turns the DIMENSION effect and heater on. Both the status lamp and thermostat lamp turn red. The heater is now on high setting.

Pressing and holding the button will adjust the thermostat setting and thermostat lamp as below:

Thermostat lamp colour

Green

Amber

Red

Thermostat setting

Low

Medium

High

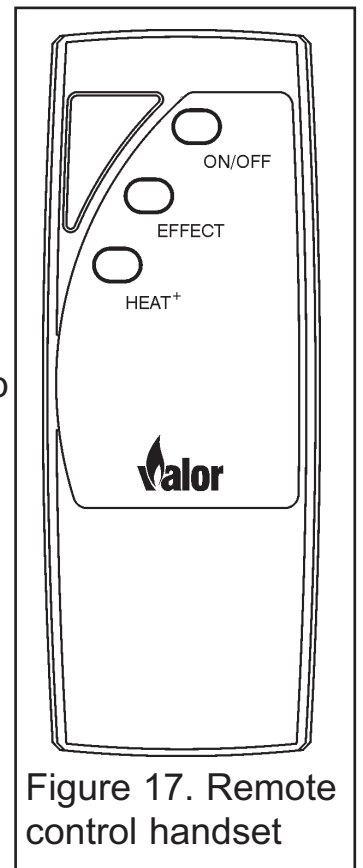

Figure 17. Remote control handset

INSTALLER AND OWNER GUIDE

Pressing the red 'ON/OFF' button.

Pressing this button at any time whilst the DIMENSION effect and heater are in operation will turn the DIMENSION effect and heater off.

Manual Control - What is it and why is it there?

The manual control is there as a back up. If the remote control has been damaged, lost, or the batteries life has expired, the manual control is will enable the DIMENSION effect and heater to be operated.

The control is located at the bottom left hand corner of the heater.

What does the button do?

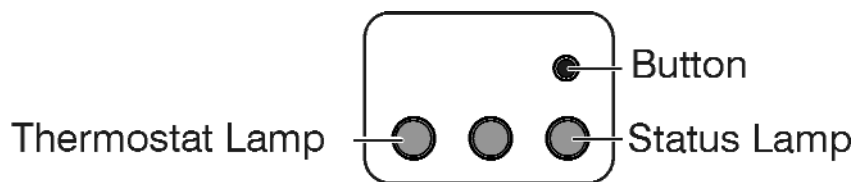

Press the button once.

This turns the DIMENSION effect on and turns the status lamp amber.

Press the button a second time.

This turns the DIMENSION effect and heater on. Both the status lamp and thermostat lamp turn red. The heater is now on high setting.

Pressing and holding the button will adjust the thermostat range and thermostat lamp as below:

Thermostat lamp colour

Green
Amber
Red

Thermostat setting

Low
Medium
High

Press the button a third time.

This turns heater DIMENSION effect off.

7. CLEANING AND MAINTAINING THE HEATER

Important Safety.

Before undertaking maintenance always disconnect the heater from the electricity supply by removing the 3 pin plug and allowing the heater to cool.

How do I Clean my heater?

The heater and plastic parts need only to be wiped clean with a dry soft cloth; do not use polishes or abrasive materials. This is especially important when cleaning the effects screen.

I have a problem with my heater!

1. My remote control does not work.

The batteries in the remote control handset probably need replacing - See section 4 and figure 2. The heater can be operated manually as on page 19.

2. My heater is switched on but there is no light or heat.

The first thing to do is check the wall socket. To do this plug in a known working appliance. If the appliance you have plugged in works then there is a good chance that the problem lies with the 13 Amp fuse in the heater plug. If either fuse or socket is suspected, have them checked by an electrician.

3. My heater is on but there is no heat and the heater fan has stopped.

The heating element on the heater has a fixed 2kW output, and is controlled by an electronic thermostat. The heating element operates to reach a preset temperature, which when achieved, will result in the heating element and heater fan switching off. When the thermostat detects a temperature below the preset temperature, the heater fan and heating element will switch on automatically, according to room temperature and chosen thermostat setting. The heater fan and element will therefore cycle off and on during normal operation.

- Alternatively check the thermostat lamp setting. It may be that you want the room warmer and need to increase the thermostat setting.

<u>Thermostat lamp colour</u>	<u>Thermostat setting</u>
Green	Low
Amber	Medium
Red	High

- Alternatively a cut out device is fitted to the heater to prevent damage due to over heating. If it operates due to an obstruction in the airflow, the heater must be turned off and allowed to cool for 15 minutes and the obstruction removed before restarting.

INSTALLER AND OWNER GUIDE

4. I have a problem that is different to those in the previous examples 1- 4.

For general advice about your heater, to report faults, arrange for your heater to be serviced, or for sales and product information call 0844 8711 565. Callers in the Republic of Ireland please telephone 0044 844 8711 565.

For spares inquiries

Spare parts are available nationwide via the 'interpart stockist network'. For your local stockist consult Yellow pages under 'Central Heating'.

When ordering spare parts please have the below information available. This will help us to deal with your call quicker and avoid you having to make a second call.

- Your Post Code
- Type of Heater (Electric or gas)
- The fault, problem or request.
- Model, Name and serial number (This information can be found on a small label attached to the lower right of the heater (See figure 18) and should also have been recorded on the last page of this guide.

8. ENVIRONMENT

Environmental Protection.

Waste electrical products should not be disposed of with household waste. Please recycle where facilities exist. Check with your local authority or retailer for recycling advice.

What should I do when I'm ready to dispose of my heater?



The plug should be removed from the mains cable and the mains cable cut from the heater. These should be disposed of with the heater.

Information for the customer

Standard Warranty Terms & Conditions

The warranty is for 12 months subject to contract.

In the United Kingdom servicing can be carried out either by a **heateam** service engineer or a suitably qualified person.

You must register your heater with **heateam**, the service division of Baxi Heating UK Limited, either by completing and returning the registration card or calling our free telephone registration line on **0800 032 72 44**.

Our promise to you

If you experience a fault with your new heater, we aim to provide a safe and high quality repair service supported by our dedicated national network of highly skilled engineers. Nothing in this warranty will affect your statutory rights.

What you need to do if you experience a problem with the operation of the heater;

Read section 7 of this guide “Cleaning and maintaining the heater”. If the problem cannot be resolved simply call our service division **heateam** on **08706 090 081** to book an engineer visit or for any general advice that you may need. Our contact centre is open Monday to Friday 8am – 6pm, weekends and Bank Holidays 8.30am – 2pm, excluding Christmas Day and New Years day.

When calling **heateam**, it would be helpful if you could have the following information to hand:-

1. Heater serial number
2. Heater brand and model number
3. Date of installation
4. Proof of purchase (If you do not have the heater serial number)

Note: details 1 – 3 can be found on the last page of this guide.

What this warranty covers

Free of charge repair or replacement of components found to be of faulty manufacture.

Free of charge replacement of the complete unit providing the failure is related to a manufacturing fault that cannot be repaired or is uneconomic to repair.

INSTALLER AND OWNER GUIDE

What this warranty does not cover

Repairs to heaters which haven't been installed properly and as set out in this guide.

Faults caused by inadequate supply of electricity.

Reimbursement of any third party repair or replacement costs that we haven't been told about or agreed with you in advance.

Compensation or consequential losses (e.g. loss of earnings, business losses, stress and inconvenience) arising from a production breakdown, including repair delays caused by factors outside our reasonable control.

INSTALLER AND OWNER GUIDE

INSTALLER AND OWNER GUIDE

INSTALLER AND OWNER GUIDE

To be completed by the customer:

Model

Serial number (Can be found on the information label - See figure 18)

A LABEL CONTAINING THE SERIAL NUMBER MAY HAVE BEEN PLACED INSIDE THIS BOX.

Fascia name (Block Capitals)

Fascia code - Can be found close to the information label (Block Capitals)

A LABEL CONTAINING THE FASCIA CODE MAY HAVE BEEN PLACED INSIDE THIS BOX.

Brand (Please tick)

Baxi

Valor

Wonderfire Other.....

Date of Installation

D D M M Y Y

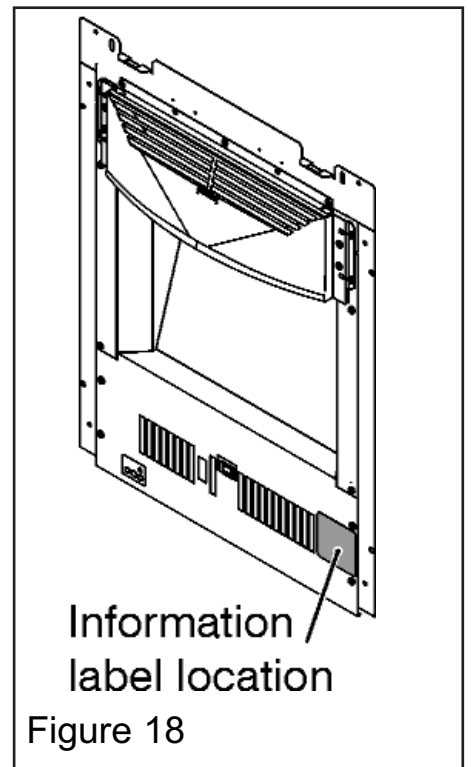



www.valordimension.co.uk