

VALOR FIRES

INSTALLATION AND OWNER GUIDE

Model 754

INSET LIVE FUEL EFFECT GAS FIRE

Fitted with one of the following fascia.

Amour, Aspect, Aspect Glass,
Eclipse, Fascination, Landscape,
Serenity, Tranquility or
Visia

(GC No. 32-032-59)



We trust that this guide gives sufficient details to enable this appliance to be installed and maintained satisfactorily. However, if further information is required, our **Valor Fires Technical Helpline** will be pleased to help.

Telephone **0844 8711 565** (National call rates apply in the United Kingdom).

In the Republic of Ireland
Telephone **0044 844 8711 565**.



BAXI • VALOR • WONDERFIRE

INSTALLER: Please leave this guide with the owner

INSTALLER GUIDE

THIS APPLIANCE IS FOR USE WITH NATURAL GAS (G20).

**WHEN CONVERTED USING CONVERSION KIT NUMBER 05754M1 THE
'FASCINATION' MODEL IS FOR USE WITH PROPANE GAS (G31).**

**THIS APPLIANCE IS SUITABLE ONLY FOR INSTALLATION IN THE UNITED
KINGDOM (GB) AND THE REPUBLIC OF IRELAND (IE).**

© Baxi Heating U.K. Limited 2008.

All rights reserved. No part of this publication may be reproduced in any material form (including photocopying), stored in any medium by electronic means (including in any retrieval system or database) or transmitted, in any form or by any means, whether electronic, mechanical, recording or otherwise, without the prior written permission of the copyright owner.

Applications for the copyright owner's permission to reproduce any part of this publication should be made, giving details of the proposed use, to the following address: The Company Secretary, Baxi Heating UK Limited, The Wyvern Business Park, Stanier Way, Derby, DE21 6BF.

Warning: Any person who does any unauthorised act in relation to a copyright work may be liable to criminal prosecution and civil claims for damages.

VALOR FIRES

Valor Fires, Erdington, Birmingham B24 9QP
www.firesandstoves.co.uk

Because our policy is one of constant development and improvement, details may vary slightly from those given in this publication

INSTALLER GUIDE

Safety First.

Valor Fires fires are CE Approved and designed to meet the appropriate British Standards and Safety Marks.



Quality and Excellence.

All Valor Fires fires are manufactured to the highest standards of quality and excellence and are manufactured under a BS EN ISO 9001 quality system accepted by the British Standards Institute.



The Highest Standards

Valor Fires is a member of SBGI and HHIC (Heating and Hot water Industry Council) that work to ensure high standards of safety, quality and performance.



Careful Installation

Valor Fires is a CORGI registered company. All our gas fires must be installed by a competent CORGI Registered Installer in accordance with our Installer Guide and should not be fitted directly on to a carpet or floor of combustible material.



INSTALLER GUIDE

FOR OWNER GUIDE SEE PAGES 44 TO 59

INSTALLER GUIDE

CONTENTS

<u>Section</u>	<u>Heading</u>	<u>Page</u>
	INSTALLER GUIDE	4 - 43
	OWNER GUIDE	44 - 59
1.	SAFETY	6
2.	ACCESSORY LIST	6
3.	APPLIANCE DATA	7
4.	GENERAL INSTALLATION REQUIREMENTS	9
5.	PACK CONTENTS	17
6.	FIREPLACE CHECK	19
7.	IGNITION CHECK	21
8.	GAS SUPPLY CONNECTION	21
9.	PREPARING APPLIANCE FOR INSTALLATION	22
10.	HOTBOX INSTALLATION	24
	10.1 Method 1 - Front fixing to fireplace surround.	24
	10.2 Method 2 - Cable retention and floor fixing.	25
	10.3 Sealing floor front - all installations.	27
11.	BURNER & SUPPLY PIPE INSTALLATION	27
12.	FITTING THE CERAMIC FUEL EFFECT	29
13.	FULL OPERATING CHECKS	29
	13.1 Check the control settings.	29
	13.1.1 Lighting the burner.	29
	13.1.2 Operating the burner.	30
	13.2 Check for spillage.	30
	13.3 Flame supervision and spillage monitoring system.	31
14.	FASCIA INSTALLATION	31
15.	FINAL REVIEW	36
16.	SERVICING & PARTS REPLACEMENT	38
	16.1 To remove the fascia.	39
	16.2 To remove the burner unit.	40
	16.3 To remove the pilot unit.	41
	16.4 To remove the gas valve.	41
	16.5 To remove the piezo generator.	42
	16.6 To grease the control tap.	42
	16.7 To replace the burner.	42
	16.8 To remove the main burner injector.	43
	16.9 To remove the appliance from the fireplace.	43

INSTALLER GUIDE

1. SAFETY

Installer

Before continuing any further with the installation of this appliance please read the following guide to manual handling:

- The approximate lifting weight (kg) of this appliance is as below:

<u>Model</u>	<u>Heat Engine</u>	<u>Fascia</u>	<u>Total</u>
Amour	7.21	3.79	11.0
Aspect	7.21	3.79	11.0
Aspect Glass	7.21	5.75	12.96
Eclipse	7.21	3.79	11.0
Fascination	7.21	8.79	16.0
Landscape	7.21	6.89	14.1
Serenity	7.21	7.76	14.97
Tranquility	7.21	3.79	11.0
Visia	7.21	6.11	13.32

- One person should be sufficient to lift the fire. If for any reason this weight is considered too heavy then obtain assistance.
- When lifting always keep your back straight. Bend your legs and not your back.
- Avoid twisting at the waist. It is better to reposition your feet.
- Avoid upper body/top heavy bending. Do not lean forward or sideways whilst handling the fire.
- Always grip with the palm of the hand. Do not use the tips of fingers for support.
- Always keep the fire as close to the body as possible. This will minimise the cantilever action.
- Use gloves to provide additional grip.
- Always use assistance if required.

2. ACCESSORY LIST

The following accessories are available: -

Description

Part Number

Pre cast and clay flue block spacer kit

05654K1

LPG conversion kit for '**Fascination**' model **only**

05754M1

INSTALLER GUIDE

3. APPLIANCE DATA

Gas	Natural (G20)	Propane (G31)*
Inlet Pressure	20mbar	37mbar
Aspect, Amour, Eclipse, Landscape, Serenity and Visia - Input Max. (Gross)	5.1kW (17,400 Btu/h)	Not available
Aspect, Amour, Eclipse, Landscape, Serenity and Visia - Input Min. (Gross)	3.0kW (10,236 Btu/h)	Not available
Aspect Glass and Tranquility Input Max. (Gross)	5.2kW (17,400 Btu/h)	Not available
Aspect Glass and Tranquility Input Min. (Gross)	3.1kW (10,236 Btu/h)	Not available
Fascination - Input Max. (Gross)	5.5kW (18,766 Btu/h)	5.0kW (17,060 Btu/h)
Fascination - Input - Min. (Gross)	3.1kW (10,577 Btu/h)	4.6kW (15,695 Btu/h)
Inlet Test Pressure (Cold)	20.0 ± 1.0mbar (8.0 ± 0.4in w.g.)	37.0 ± 1.0mbar (14.85 ± 0.4in w.g.)
Gas Connection	8mm pipe	8mm pipe
Burner Injector	Stereomatic Cat. 82 Size 065	StereomaticSize 110
Pilot & Atmosphere Sensing Device	Copreci Ref. O.D.S 21500/166	Copreci Ref. O.D.S 21500/166 Fitted with RBM 180 - 02 injector
Ignition	Integral piezo (Mounted on gas valve)	Integral piezo (Mounted on gas valve)
Aeration	Non-adjustable	Non-adjustable

* When converted using conversion kit number 05754M1.

The appliance information label is located on a plate at the base of the fire. This can be seen by lowering the bottom front cover of the fascia.

INSTALLER GUIDE

The efficiency of this appliance has been measured as specified in BS 7977 - 1 and the result is as below :

<u>Model</u>	<u>Efficiency % (Gross)</u>
Amour, Aspect, Eclipse, Landscape, Serenity and Visia.	51
Aspect Glass, Tranquility and Fascination.	45
Fascination when converted to LPG.	46

The gross calorific value of the fuel has been used for this efficiency calculation. The test data from which it has been calculated has been certified by Advantica Certification services (0087). The efficiency value may be used in the UK Government's Standard Assessment Procedure (SAP) for energy rating of dwellings.

The conversion of **net** efficiency to **gross** was achieved by multiplying the net efficiency by the following conversion factor from Table E3 of SAP 2005, rounding down to the nearest whole number.

Gas	Conversion factor from net to gross efficiency
Natural Gas	0.901
LPG	0.921

This product uses fuel effect pieces containing Refractory Ceramic Fibres (RCF), which are man-made vitreous silicate fibres. Excessive exposure to these materials may cause irritation to eyes, skin and respiratory tract. Consequently, it is important to take care when handling these articles to ensure that the release of dust is kept to a minimum. To ensure that the release of fibres from these RCF articles is kept to a minimum, during installation and servicing we recommend that you use a HEPA filtered vacuum to remove any dust and soot accumulated in and around the fire before and after working on the fire. When replacing these articles we recommend that the replaced items are not broken up, but are sealed within a heavy duty polythene bag, clearly labelled as RCF waste. RCF waste is classed as a stable, non-reactive hazardous waste and may be disposed at a landfill licensed to accept such waste. Protective clothing is not required when handling these articles, but we recommend you follow the normal hygiene rules of not smoking, eating or drinking in the work area and always wash your hands before eating or drinking.

This appliance does not contain any component manufactured from asbestos or asbestos related products.

4. GENERAL INSTALLATION REQUIREMENTS

4.1 The installation must be in accordance with these instructions.

For the user's protection, in the United Kingdom it is the law that all gas appliances are installed by competent persons in accordance with the current edition of the Gas Safety (Installation and Use) Regulations. Failure to install the appliance correctly could lead to prosecution. CORGI requires its members to work to recognised standards.

In the United Kingdom the installation must also be in accordance with:

All the relevant parts of local regulations.

All relevant codes of practice.

The relevant parts of the current editions of the following British Standards:-

BS EN 1856 Part 1 which replaces BS 715.

BS EN 1858 which replaces BS 1289 Part 1.

BS EN 1806 which replaces BS 1289 Part 2.

BS EN 1856 Part 1 which replaces BS 4543 Part 2.

BS 5440 Part 1.

BS 5440 Part 2.

BS 6461 Part 1.

BS 1251.

BS EN 1806.

BS 5871 Part 2.

BS 6891.

BS 8303.

In England and Wales, the current edition of the Building Regulations issued by the Department of the Environment and the Welsh Office.

In Scotland, the current edition of the Building Standards (Scotland) Regulations issued by the Scottish Executive.

In Northern Ireland, the current edition of the Building regulations (Northern Ireland) issued by the Department of the Environment for Northern Ireland.

In the republic of Ireland the installation must also conform to the relevant parts of:

a) The current edition of IS 813 "Domestic gas installations"

b) All relevant national and local rules in force.

Where no specific instructions are given, reference should be made to the relevant British Standard Code of Practice.

4.2 In the United Kingdom, as supplied, the appliance can be installed in the following situations:

4.2.1 To a fireplace complete with surround and hearth as shown in figure 1 and complying with BS1251 after removal of the fireback and sufficient material behind the fireback for a debris catchment space. The required fireplace, hearth, debris catchment area and clearance dimensions are shown in figure 1.

INSTALLER GUIDE

4.2.1.1 'Hole-in-the-wall' installations.

- It is recommended that a hearth should be installed as in figure 1. If a hearth is not fitted, the fire must be installed so that the distance from the base of the fireplace opening in the wall to the finished floor level is at least 85mm. Where there is no floor covering or carpet and the floor is of a type that is likely to be covered in such a way in the future then the distance from the base of the fireplace opening in the wall to the floor level should be increased to at least 160mm. The minimum shelf height will have to be taken from the base of the fireplace opening.

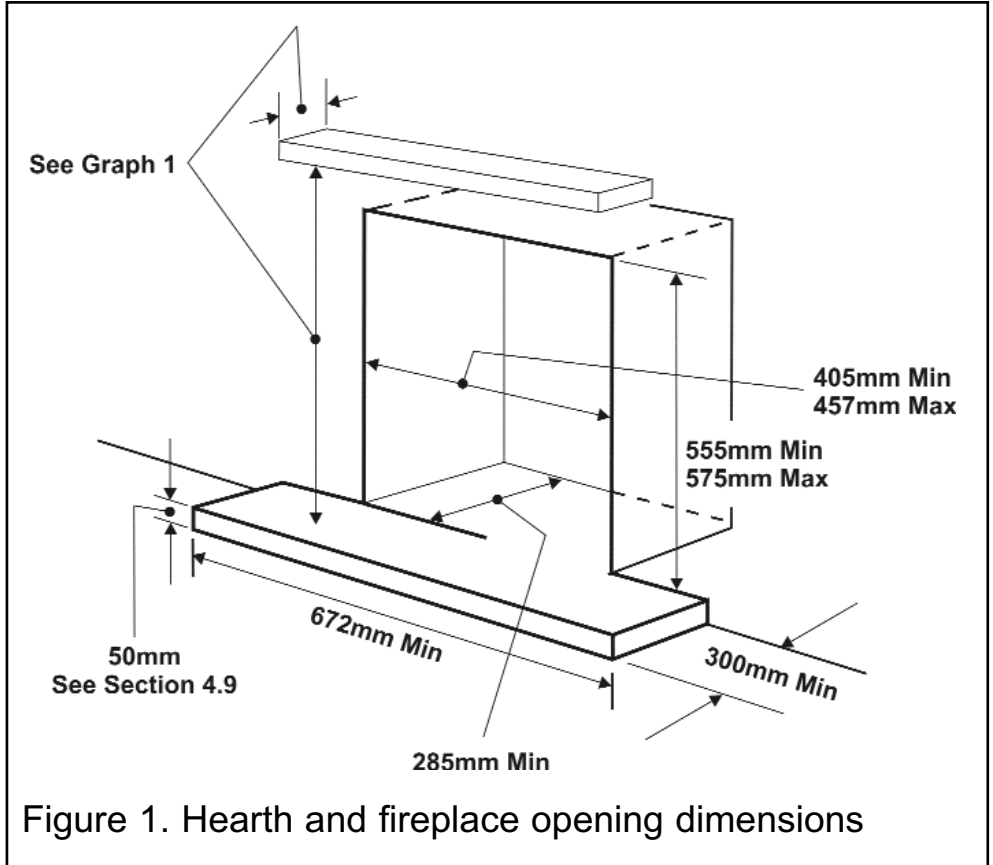

Figure 1. Hearth and fireplace opening dimensions

- (All models except Fascination, Tranquility and Aspect Glass that are glass fronted appliances).

To protect from the risk of burns and ignition of clothing a tactile separator shall be used. The hearth detailed in section 4.9 meets the requirements for a tactile separator. If this is not used then a 672mm long fender, kerb, horizontal bar, or other barrier, being fixed not less than 50mm above floor level and positioned 300mm in front of the fixing plane of the fire will meet the requirement.

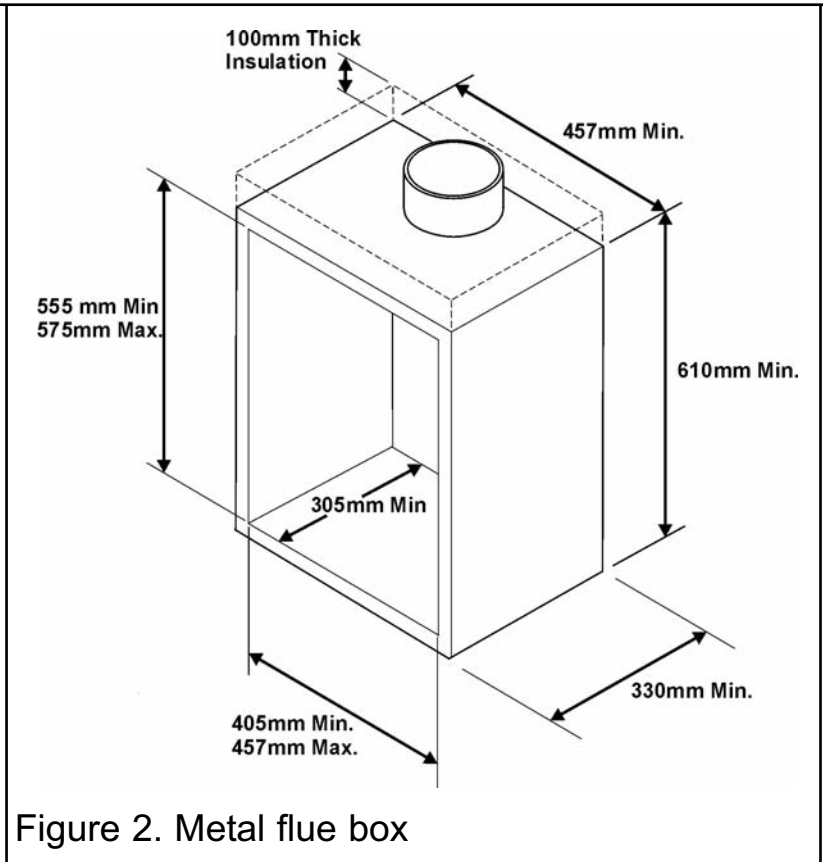

Figure 2. Metal flue box

INSTALLER GUIDE

4.2.2 To a fireplace incorporating a metal flue box complying with the constructional requirements of the current edition of BS EN 1856 Part 1 or BS715. The dimensions of the flue box must conform to those shown in figure 2.

4.2.3 A precast concrete or clay flue block system conforming to BS1289 or BS EN 1806 with dimensions as in figure 3 or using a 05654K1 spacer kit (Installation Instructions part number 3003095). BS EN 1806 and BS1289 recommend that there should be an air space or insulation between the flue blocks and the plaster because heat transfer may cause cracking on directly plastered flues. However, generally this appliance is suitable for installations under all circumstances unless there is a history of cracking problems. Remember that faults such as cracking may be caused by poorly built and restrictive flues, e.g. mortar extrusions, too many bends, flue heights below three metres, restrictive terminations etc (See figure3).

4.2.4 If the fireplace opening is greater than the acceptable dimensions given in this guide, do not use the back of a fire surround or marble to reduce the opening. This may cause cracking of the surround back or marble.

4.3 Suitable flues and minimum flue sizes are as follows: -

It should be noted that, as with many appliances, sharp bends or horizontal runs in metal flues at the top of the system can be a cause of problems in these types of installation.

- 225mm x 225mm conventional brick flue.
- 175mm diameter lined brick or stone flue.
- 200mm diameter factory made insulated flue manufactured to BS EN 1856 Part 1 or BS4543.
- 175mm diameter flue pipe. See BS6461 Part 1 for suitable materials.
- Single wall, twin wall or flexible flue liner with a minimum diameter of 125mm. The

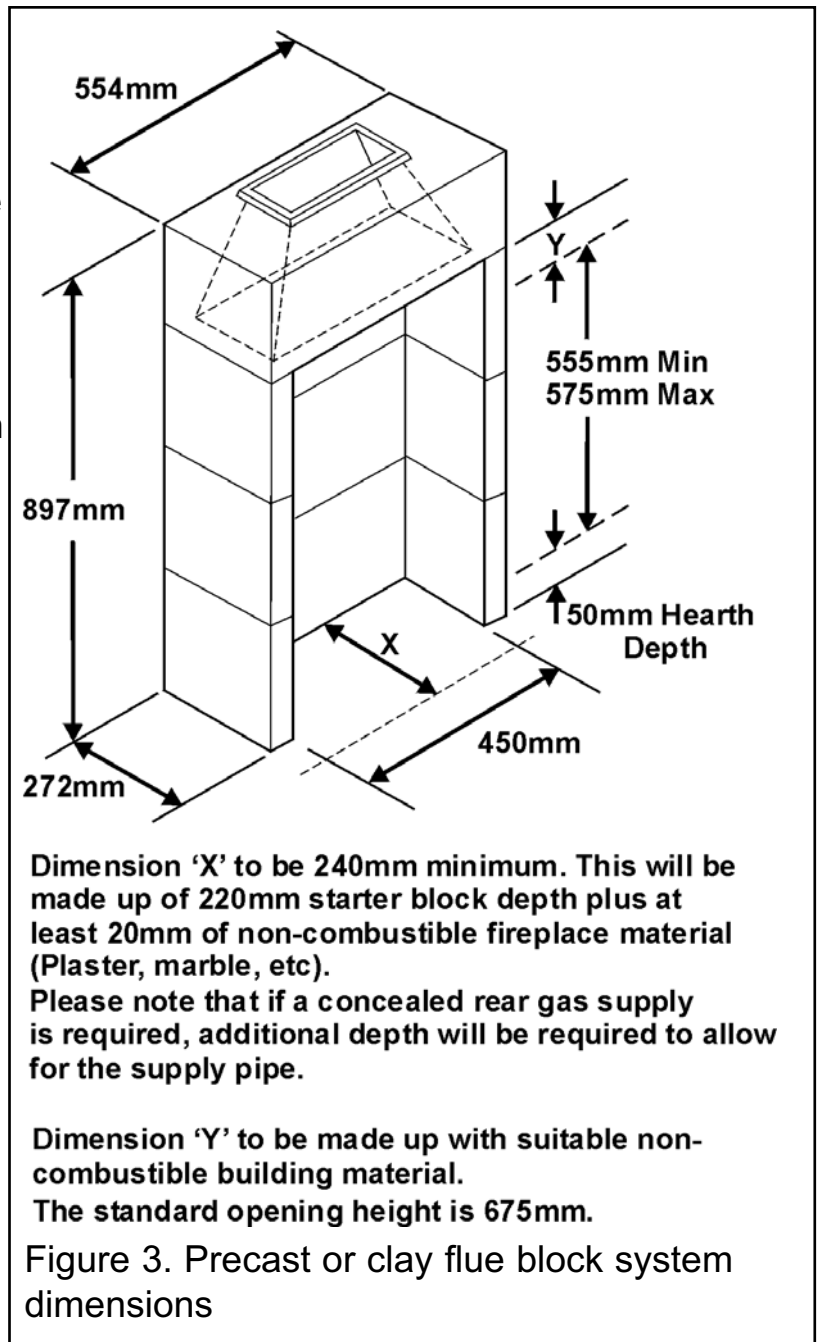

INSTALLER GUIDE

materials to be used are stainless steel or aluminium as specified in BS EN 1856 Part 1 or BS715. The liner must be sealed to the surrounding area above the fireplace opening and to the top of the chimney. An approved terminal must be fitted.

- A properly constructed precast concrete or clay flue system conforming to BS1289 or BS EN 1806. This system is only suitable if the conditions stated in section 4.2.3 are met.

4.4 The flue must conform to BS 5440: Part 1 in design and installation.

The flue, measured from the bottom of the fireplace opening to the bottom of the terminal, shall be not less than 3m in actual vertical height. When calculated in accordance with BS 5440: Part 1 Annex A, the minimum **equivalent** height of the flue shall be 2.0m of 125mm-dia. flue pipe.

4.5 The flue must not be used for any other appliance or application.

4.6 Any chimney damper or restrictor should be removed. If removal is not possible, they must be secured in the open position.

4.7 If the appliance is intended to be installed to a chimney that was previously used for solid fuel, the flue must be swept clean prior to installation. All flues should be inspected for soundness and freedom from blockages.

4.8 If the fireplace opening is an underfloor draught type, it must be sealed to stop any draughts.

4.9 The appliance must be mounted behind a non-combustible hearth unless the conditions of section 4.2.1.1 are met (N.B. conglomerate marble hearths are considered as non-combustible). The appliance can be fitted to a purpose made proprietary class "O"-150°C surround. The hearth material must be at least 12mm thick. The periphery of the hearth (or fender) should be at least 50mm above floor level to discourage the placing of carpets or rugs over it.

The surface of the hearth must be sufficiently flat to enable the bottom of the fascia and the bottom front cover to be aligned horizontally. Any excessive unevenness (uneven tiles, Cotswold stone, etc.) should be rectified.

The appliance must not stand on combustible materials or carpets.

4.10 The front face of the fireplace should be reasonably flat over the area covered by the hotbox top and side flange seals to ensure good sealing. These faces should be made good if necessary.

The fireplace floor should be reasonably flat to ensure that a good seal with the hotbox can be made.

4.11 Note that soft wall coverings (e.g. embossed vinyl, etc.) are easily affected by heat. They may scorch or become discoloured when close to a heating appliance. Please bear this in mind when installing.

INSTALLER GUIDE

4.12 This appliance must not be installed in any room that contains a bath or shower or where steam is regularly present.

4.13 An extractor fan may only be used in the same room as this appliance, or in any area from which ventilation for the appliance is taken, if it does not affect the safe performance of the appliance. Note the spillage test requirements detailed further on in this manual. If the fan is likely to affect the appliance, the appliance must not be installed unless the fan is permanently disconnected.

4.14 The minimum height from the base of the fireplace opening to the underside of any shelf made from wood or other combustible materials is shown below: -

- For a shelf up to 150mm deep
Minimum height = 700mm.
- For a shelf deeper than 150mm
Minimum height = 700mm + 12.5mm for every 25mm depth over 150mm.
(See graph 1).

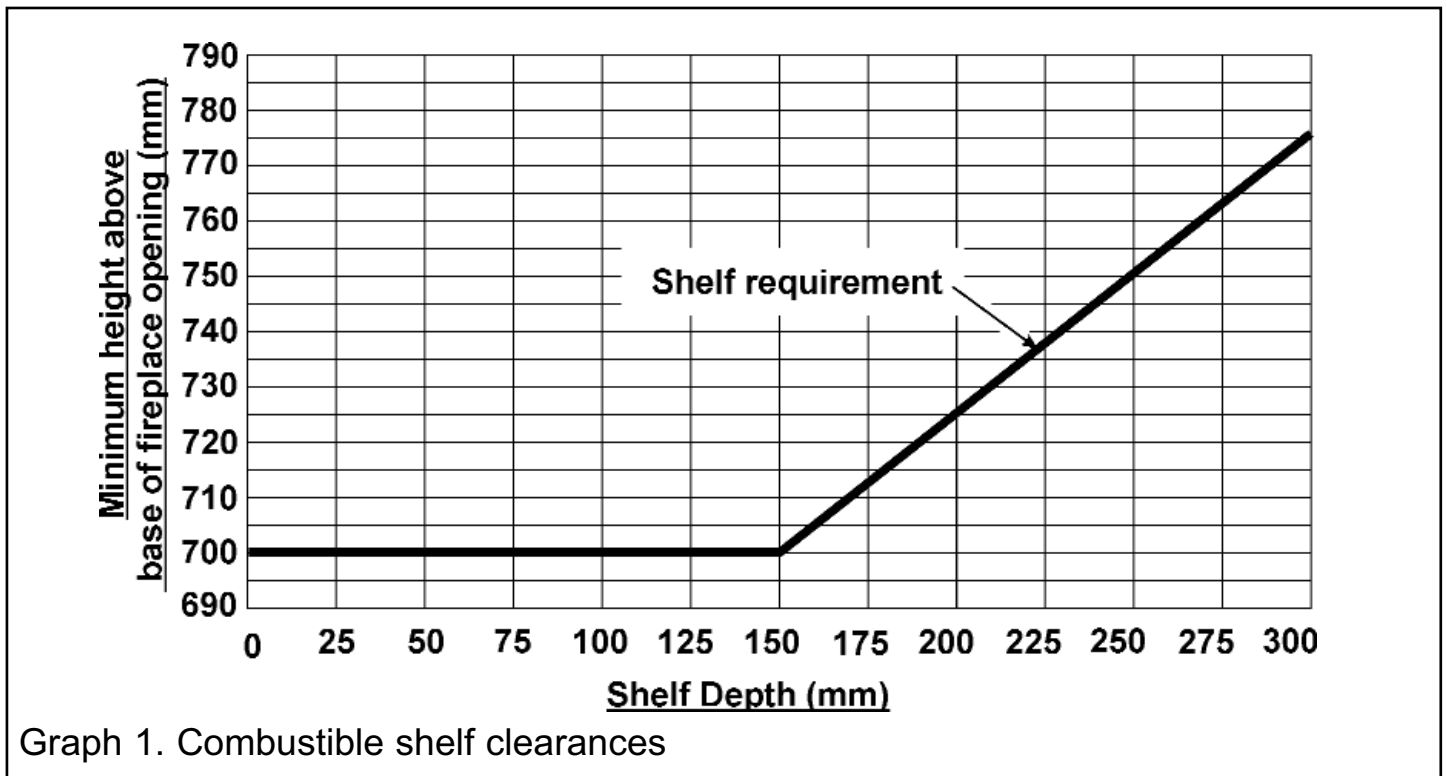

Graph 1. Combustible shelf clearances

4.15 Normal adventitious ventilation is usually sufficient to satisfy the ventilation requirements of this appliance. In GB reference should be made to BS 5871 Part 2 and in IE reference should be made to the current edition of IS 813 "Domestic Gas Installations" which makes clear the conditions that must be met to demonstrate that sufficient ventilation is available.

4.16 If the appliance is to be fitted against a wall with combustible cladding, the cladding must be removed from the area covered by the fascia. The cladding must also not touch the fascia (See figure 4). We suggest that the actual fascia is used as a template to mark the area for combustible cladding removal and that this area is

INSTALLER GUIDE

increased by at least 2mm all round. If the cladding projects forward from the fixing plane of the fire the clearance at the top of the appliance must be increased to a minimum 15mm. This will allow for fascia removal.

4.17 Proprietary terminals must comply with BS EN 1856 Part 1 / BS 715 or BS EN 1858 / BS 1289. Any terminal or termination must be positioned in accordance with BS 5440 Part 1 to ensure that the products of combustion can be safely dispersed into the outside atmosphere. Where the appliance is connected to an unlined brick

chimney it is generally unnecessary for the chimney pot to be replaced or for a terminal to be fitted unless the flue has a diameter smaller than 170mm.

4.18 The appliance is fitted with an A.S.D (Atmosphere sensing device). If the appliance closes down after a period of operation for no apparent reason, the consumer should be informed to stop using the appliance until the installation and appliance have been thoroughly checked. The A.S.D will shut the appliance down if an unacceptable amount of harmful products of combustion accumulate. Under no circumstances should the A.S.D be altered or bypassed in any way. Only a genuine manufacturers replacement part should be fitted. The individual A.S.D components are not replaceable.

4.19 A fireguard complying with BS 8423 should be fitted for the protection of young children, the elderly, or the infirm.

'Fascination', 'Tranquility' and 'Aspect Glass' fascia: The glass panel is a working surface and is hot during normal operation of the fire and whilst cooling. A fireguard complying with BS 8423 should be fitted for the protection of young children, the elderly, or the infirm.

4.20 The minimum allowable distance from the outside of the appliance fascia to a corner wall having combustible material or any other combustible surface which projects beyond the front of the appliance is shown in figure 5.

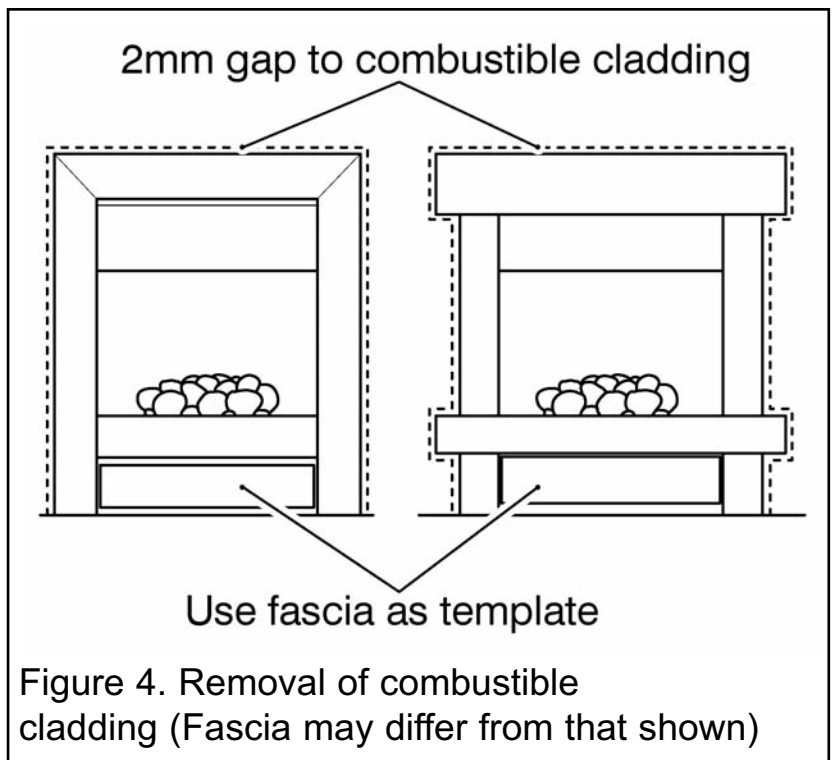

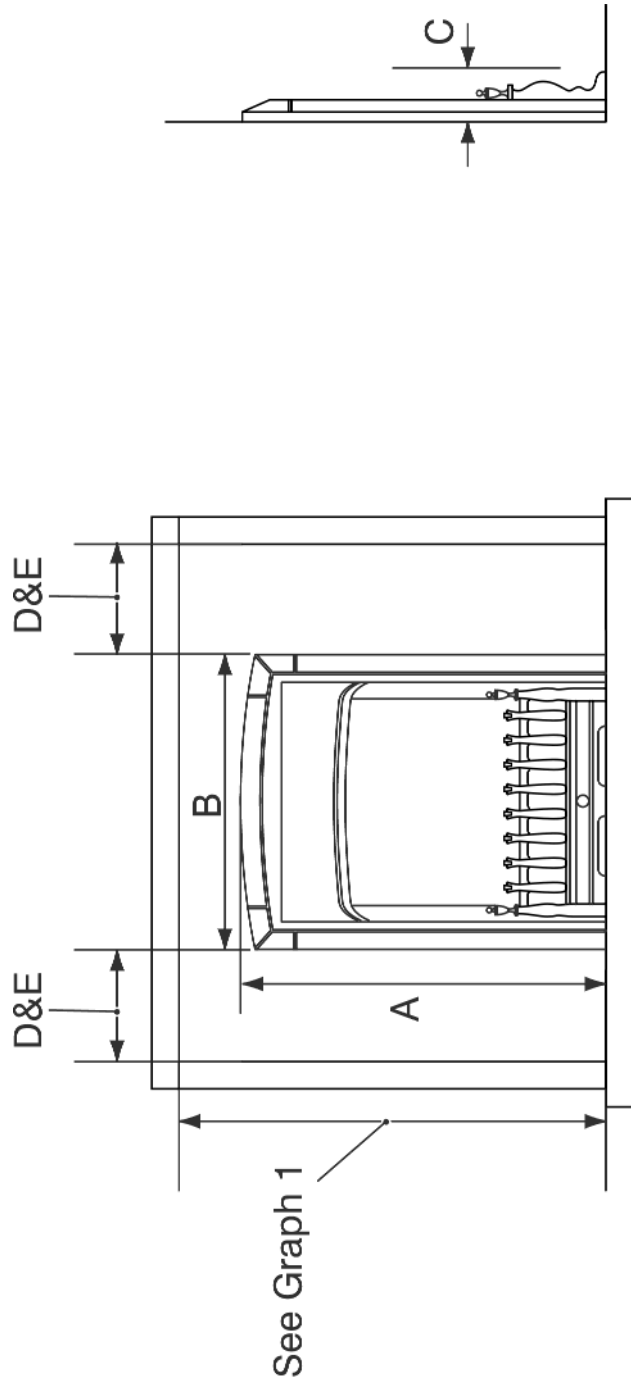

Figure 5. Appliance dimensions and clearances - SEE TABLE ON NEXT PAGE (Fascia may differ from that shown)

INSTALLER GUIDE

Key	Description	Model							
		Amour	Aspect	Eclipse	Fascination	Landscape & Serenity	Visia	Tranquility & Aspect Glass	
A	Appliance height (mm)	610	612	599	599	607	640	612	
B	Appliance width (mm)	560	505	520	520	976	930	505	
C	Appliance depth into room (mm)	30	13	25	61	72	40	50	
D	Minimum mandatory clearance to combustible surfaces projecting beyond the front of appliance (mm).	10	10	10	10	10	10	10	
E	Recommended clearance to non-combustible surfaces for access purposes (mm).	10	10	10	10	10	10	10	

Figure 5 continued. Appliance dimensions and clearances

INSTALLER GUIDE

5. PACK CONTENTS

- 1 Burner & Hotbox Unit.
- 1 Nut & olive for 8mm inlet pipe.
- 1 Inlet 'T' Connector.
- 1 Flue restrictor plate.
- 2 Screws (For flue restrictor).
- 2 Fireback spacing brackets.
- 2 Screws (For Fireback spacing brackets).
- 1 Ceramic fuel effect pack (Not shown).
- 2 Small "U" seals for hotbox side flanges.
- 1 Strip of floor sealing tape.
- 2 Black self tapping screws (For securing top of 'Landscape' and 'Serenity' fascia).
- 2 Self tapping screws (For securing the sides of 'Landscape', 'Serenity' and 'Visia' fascia).
- 6 Fibre plugs.
- 4 Woodscrews.
- 2 Fascia securing brackets and screws (For the 'Landscape', 'Serenity' and 'Visia' models).
- 2 Fire retaining cables.
- 2 Cable clamps.
- 4 Eyebolts.
- 1 Rubber grommet.
- 1 Smoke match tube.
- 1 Length of self adhesive foam seal.
- 1 Literature pack.
- 1 Fascia.
- 1 Lower hotbox baffle for Fascination.
- 4 Self tapping screws (For securing the heat baffle on 'Landscape', 'Serenity' and 'Visia' fascia).

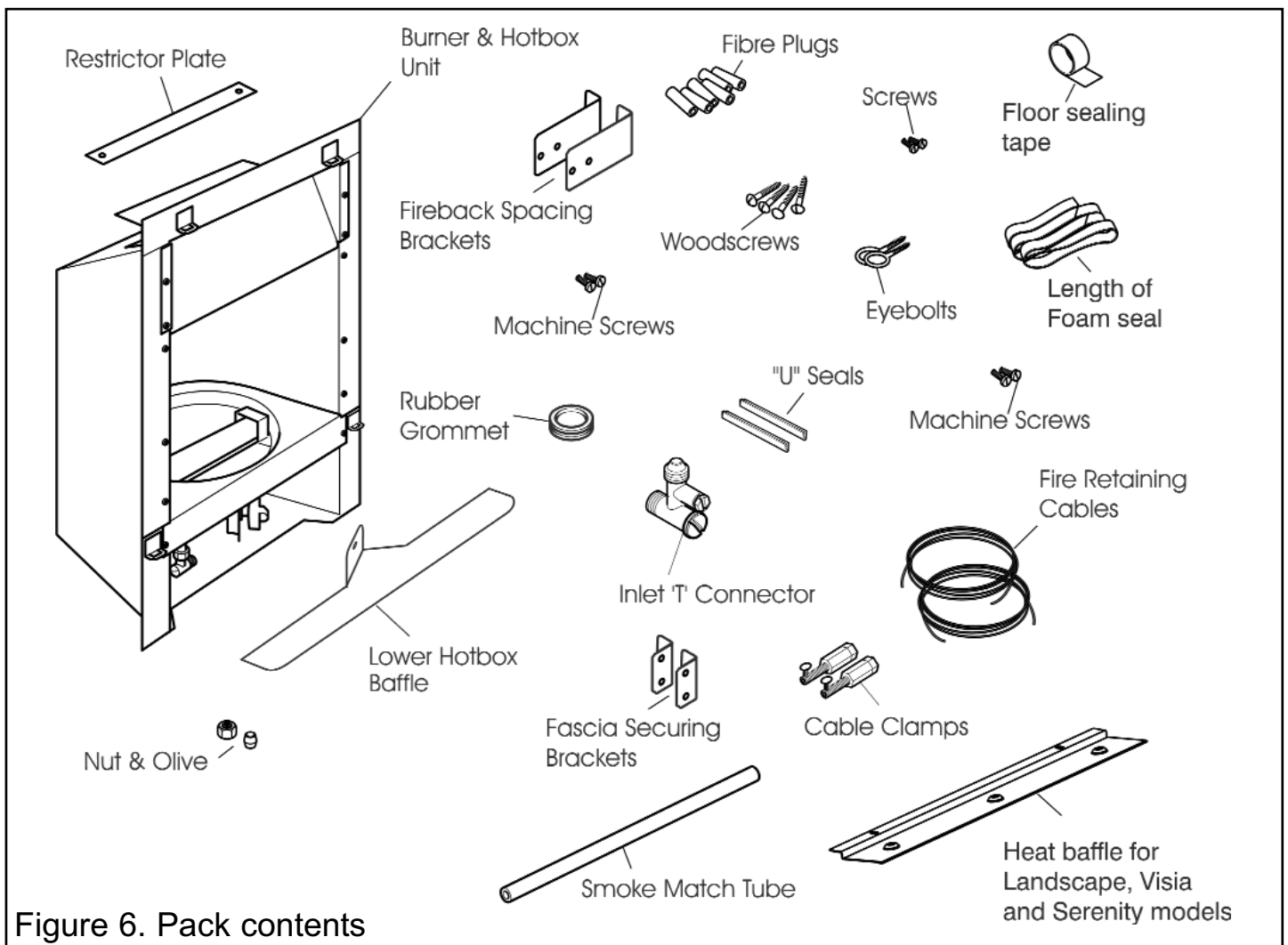

INSTALLER GUIDE

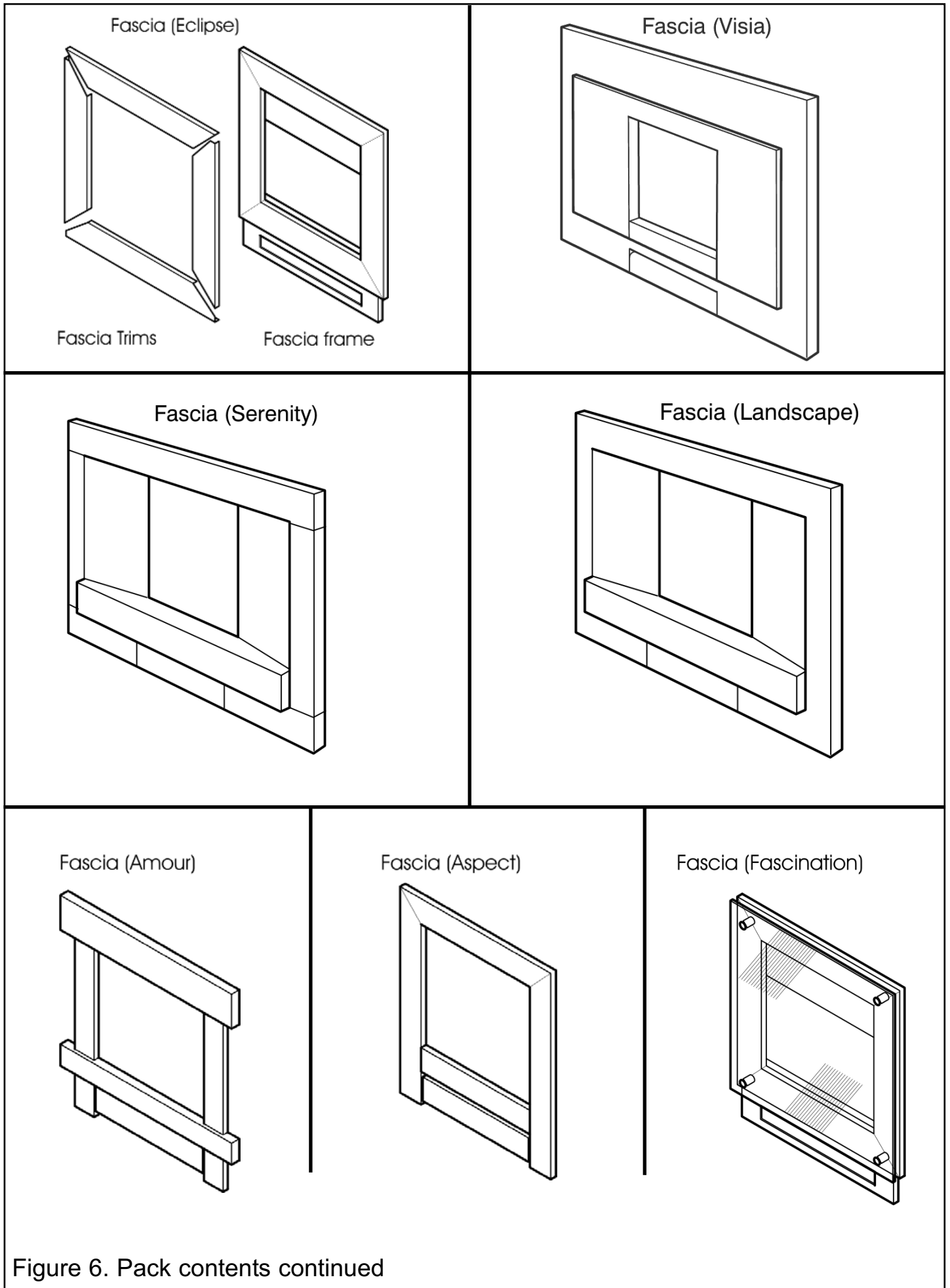
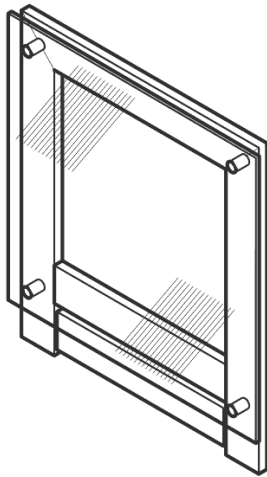

Figure 6. Pack contents continued

INSTALLER GUIDE

Fascia (Aspect Glass)



Fascia (Tranquility)

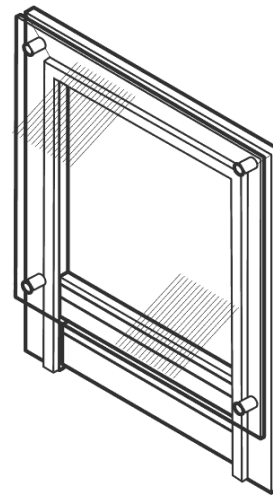

Figure 6. Pack contents continued

Carefully remove all the contents. Take special care in handling the ceramic fuel effects. Check that all the listed parts are present and in good condition. The pack may contain additional components to that stated above. These can be discarded.

6. FIREPLACE CHECK

6.1 Fireplace check.

6.1.1 Fireplace size

The fireplace must comply with the requirements described in section 4.2. This will probably entail removing the fireback and infill material behind the fireback. The debris catchment area shown in figure 7 must be kept clear of obstructions.

6.1.2 Fireplace general condition

The fireplace floor should be reasonably flat to ensure that the hotbox can be installed without it rocking and so that a good seal can be made at the bottom front of the box. The front face of the fireplace should be reasonably flat over the area covered by the hotbox top and side flange seals to ensure good sealing. These faces should be made good if necessary. If the appliance is to be fitted against a wall with combustible cladding, the cladding must be removed from

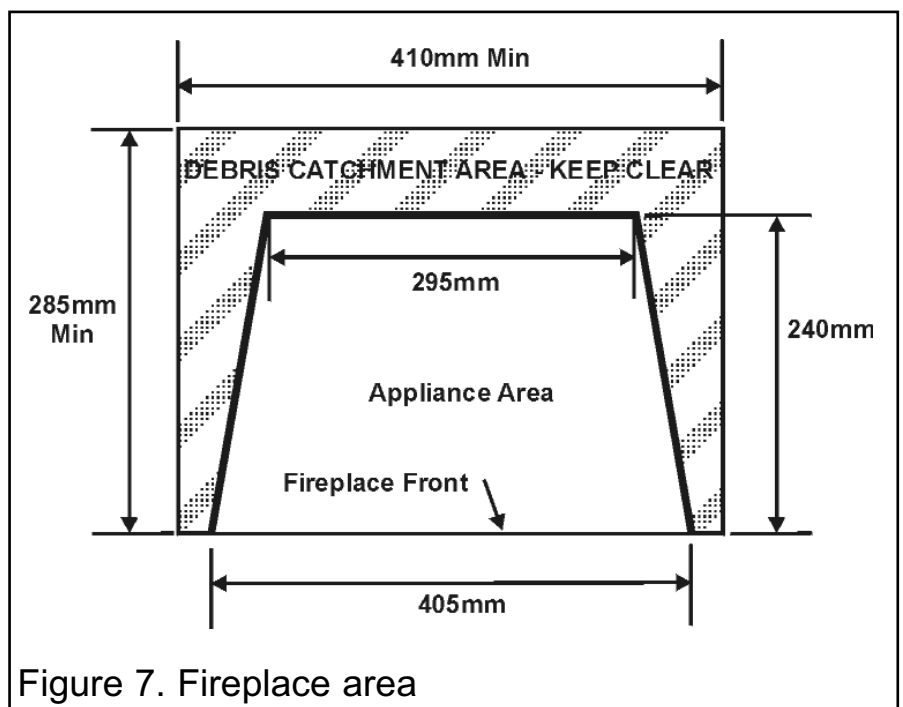

Figure 7. Fireplace area

INSTALLER GUIDE

the area covered by the fascia. The cladding must also not touch the fascia (See figure 4). We suggest that the actual fascia is used as a template to mark the area for combustible cladding removal and that this area is increased by at least 2mm all round.

6.1.3 Soundness for appliance attachment

Two primary methods of retaining the appliance are provided: -

- 1) By fixing to the fireplace front surround.
- 2) Using concealed tension cables fixed to the rear of the fireplace opening together with secondary fixing to the fireplace floor.

The methods are detailed in section 10 of this manual. Before selecting the retention method, consult with the customer. Method 2 is provided for instances where drilling holes in the front surface of the fireplace surround is unacceptable to the customer or otherwise impractical. *N.B. It is unwise to attempt to drill into marble without the proper tools and equipment.*

If method 1 is chosen, make sure that the front surround area is sound enough to take the fibre plugs and woodscrews. If necessary, make sound with suitable cement. If method 2 is chosen, make sure that the areas at the back and towards the centre of the fireplace floor are sound enough to take the eyebolts and screws. If these areas have deteriorated due to prolonged use, they should be made sound with suitable cement.

6.1.4 Installations using a metal flue box

The whole of the top surface of the metal flue box must be covered with a 100mm layer of mineral wool or equivalent insulation (See figure 2).

6.2 Fireplace flue pull.

Close all doors and windows in the room in which the appliance is to be installed. After confirming with a match that smoke is drawn into the flue, light a 13 gram smoke pellet and check that there is a definite flow through the flue. Verify outside that the smoke exits from one terminal only and that the termination is suitable. Observe where possible, upstairs rooms and loft spaces for signs of escaping smoke indicating a defective flue. If there is not a definite flow warm the flue for a few minutes and repeat the smoke pellet test. If there is still no definite flow the flue may need remedial work – **Do not fit the appliance until there is a definite flow through the flue.**

INSTALLER GUIDE

7. IGNITION CHECK

Before attempting to install, it is worth checking that the ignition system performs satisfactorily. Set the control knob to the off position. Depress the control knob and rotate it anticlockwise to the pilot ignition position. A 'click' will be heard as the integral piezo operates. A spark should be seen between the electrode and pilot tip. If there is no spark check the following: -

- Ensure that the electrode lead is connected to the terminal at the base of the electrode.
- If the above is correct, check for damage to the electrode lead.

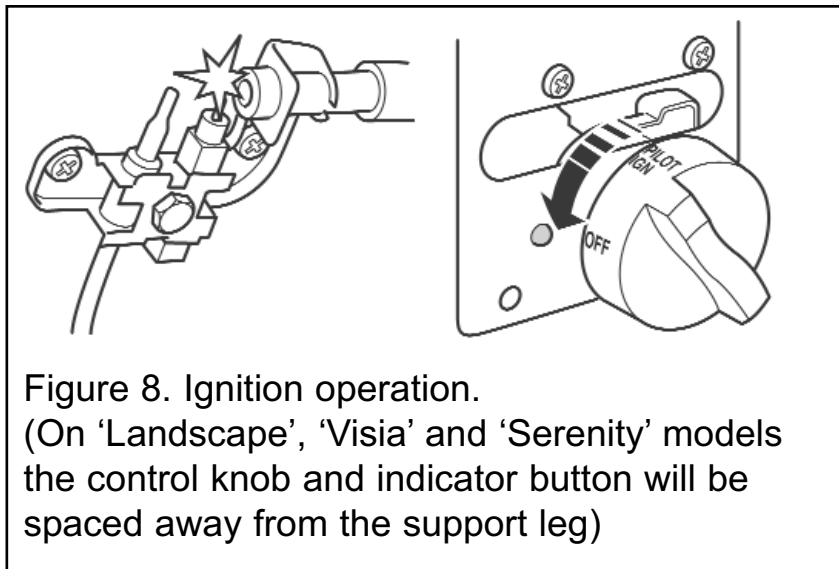

Figure 8. Ignition operation.
(On 'Landscape', 'Visia' and 'Serenity' models the control knob and indicator button will be spaced away from the support leg)

8. GAS SUPPLY CONNECTION

A nut and olive are provided for an 8mm pipe inlet connection to the 'T' connector at the bottom front of the appliance. The 'T' connector can be rotated to allow a connection from any rear-concealed connection. The 'T' connector includes a valve for isolating the gas supply and a pressure test point.

The supply pipe must be rigid material. Flexible pipe must not be used.

Concealed supply pipe connection.

If a concealed connection from inside the fireplace is required then, **before the appliance is fitted into the fireplace** it will be necessary to extend the supply line so that it will project through the hole in the back of the hotbox and run to the 'T' connector at the front. The pipe run from the supply line up to the rear opening in the hotbox must be kept away from the area which will be taken by the hotbox when it is installed. Note that the centre of the appliance inlet 'T' connector is 25mm above the fireplace floor. The inlet 'T' connector should be fitted to the supply pipe at this stage.

9. PREPARING APPLIANCE FOR INSTALLATION

1. Detach the spillage plate from the hotbox by removing the four screws (See figure 9).
2. Remove the protective film (where fitted) from the spillage plate. Place the spillage plate in a safe place away from the work area.

3. Remove the six screws from the side of the inner reflector (See figure 10).

4. Carefully lift the inner reflector and pull forward to remove. **Be careful not to scratch the top surface of the burner cover (See figure 10). The reflector may 'spring' a little. For this reason it is important to hold the edges firmly when removing.**

5. Remove the protective film from the inner reflector. Place the inner reflector in a safe place away from the work area.

6. Remove the two screws to the side of the burner cover (See figure 11)

7. Detach the burner cover by lifting clear of the burner module (See figure 11)

8. Remove the protective film (where fitted) from the burner cover. Place the burner cover in a safe place away from the work area.

9. Detach the burner unit from the hotbox by lifting clear.

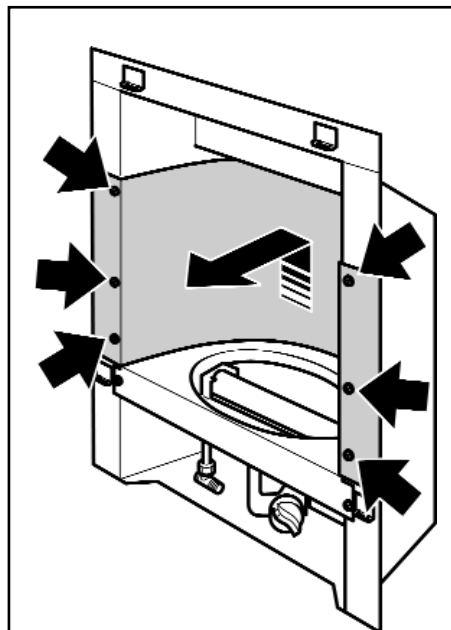

Figure 10. Removal of inner reflector

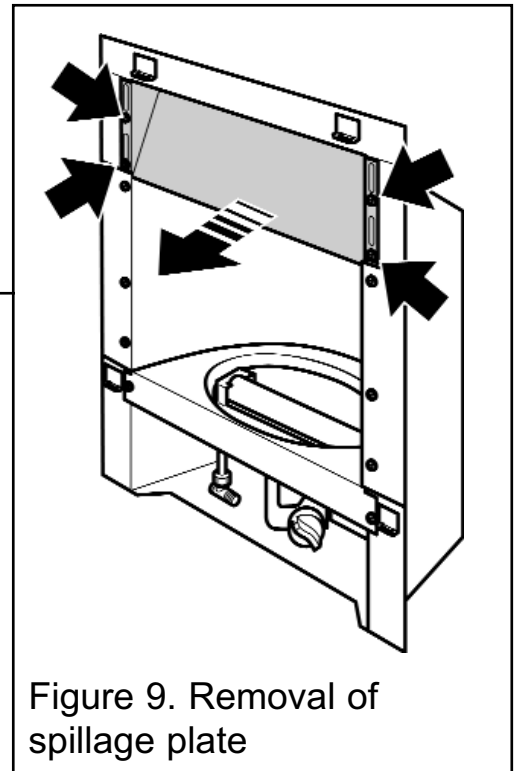

Figure 9. Removal of spillage plate

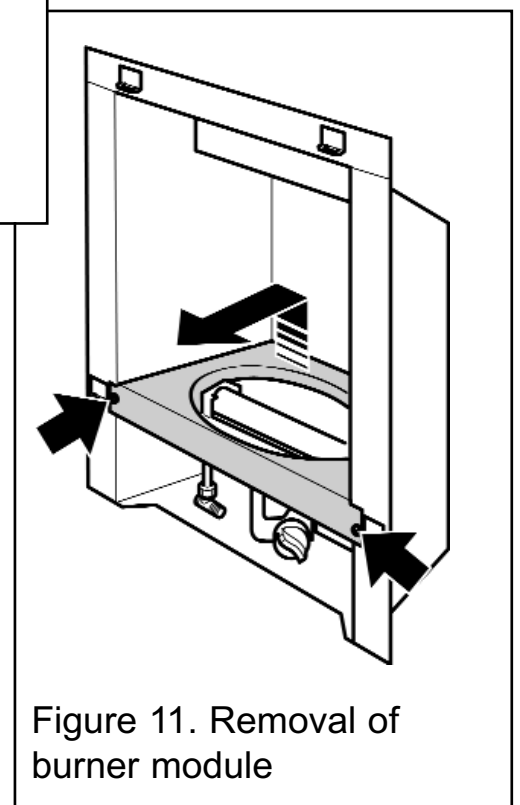

Figure 11. Removal of burner module

INSTALLER GUIDE

10. Fit the two “U” section seals to the bottom edges of the hotbox side flanges (See figure 12).

11. It is important that the grommet supplied in the loose parts pack is fitted to the hole in the rear of the convection box.

12. For concealed connection only: Pierce the grommet to allow the pipe to pass through it. The grommet should envelop the pipe. If the hole is larger than the pipe, seal it with tape. **Do not pierce the grommet unless the supply pipe is to pass through it.**

13. The appliance is supplied with two fireback spacers. **Do not fit the fireback spacers if the fire is to be installed into a precast or clay flue block system as in section 4.2.3.** These should extend backwards to ensure sufficient clearance from the back of the fireplace. Remove the label and retaining screws from the rear sides of the hotbox. Position the fireback spacer as shown in figure 13.

Secure the fireback spacers using the screws removed previously and the two supplied with the fire. **14.** This appliance is supplied with a flue restrictor for use where the flue draught is excessive. The restrictor must NOT be fitted where a precast flue or a flue liner is used. For all other installations the restrictor should be fitted. There may however, be certain exceptional circumstances where fitting the restrictor causes the fire to fail the spillage test. In such cases the restrictor will have to be removed. After removal conduct the spillage check again. The restrictor is packed loose with the appliance and is fixed with two screws (See figure 14).

‘Fascination’, ‘Aspect Glass’ and ‘Tranquility’ models.: The restrictor has two location holes and a notch along one edge. It is important that the notch is positioned to the top.

15. There is a length of self adhesive foam seal supplied with the fire. This will need to be

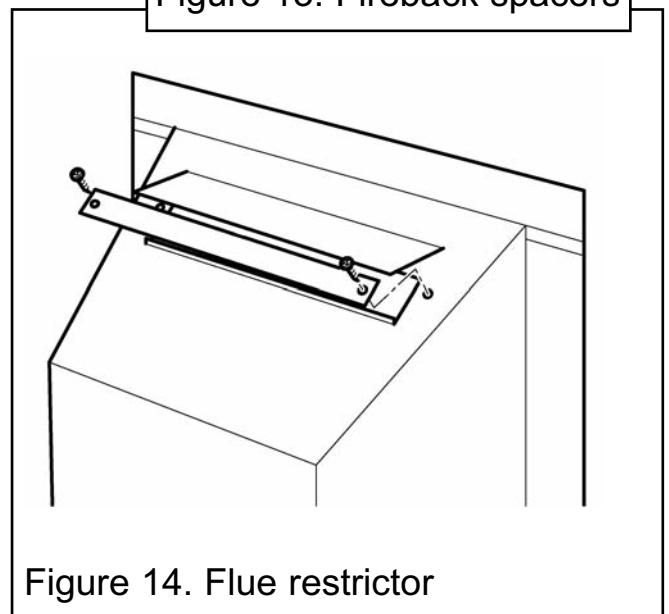
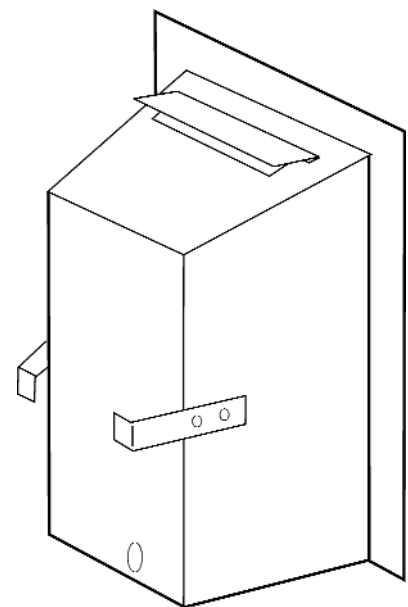
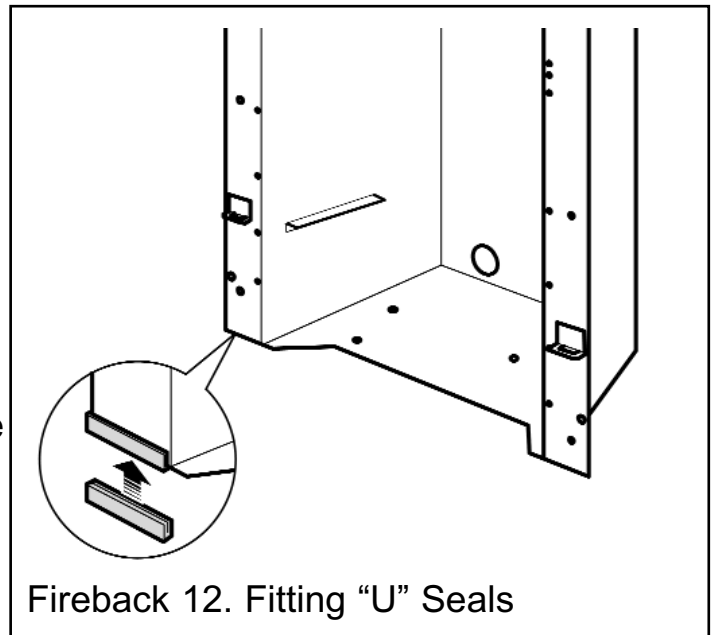

INSTALLER GUIDE

fitted to the outer rear edges of the side and top flanges of the hotbox. Cut a 485mm length of foam seal. Be careful not to stretch the seal when measuring. Remove the protective backing from the foam seal and fit this to the rear of the top flange (See figure 15). Cut two 580mm lengths. Fit these to the rear outer edges of the side flanges. Ensure that there is no gap between the foam seals where they meet at the top flange (See figure 15).

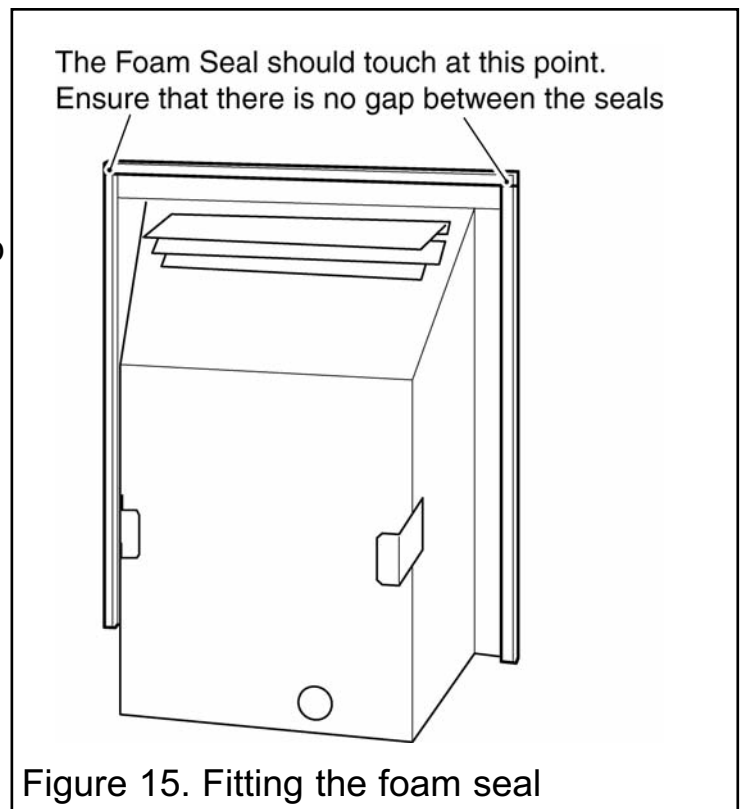

10. HOTBOX INSTALLATION

10.1 Method 1 - Front fixing to fireplace surround.

1. Make sure that the fireplace front surround area is sound enough to take the fibre plugs and woodscrews. If necessary, make sound with suitable cement.
2. Place the hotbox centrally in the fireplace in the position in which it is to be permanently installed. If a concealed connection is being used, insert the hotbox into the fireplace feeding the supply pipe through the pierced hole in the rear grommet.
3. Mark the fireplace front surround through the four fixing holes in the side flanges of the hotbox (See figure 16).
4. Remove the hotbox. Drill four holes in the fireplace front surround at the marked positions using a suitably sized masonry drill for the fibre plugs supplied.
5. Insert a fibre plug into each hole.
6. Place the hotbox back in position in the fireplace.
7. Fit a woodscrew through each hole in the hotbox flanges and tighten to seal the box to the fireplace surround.

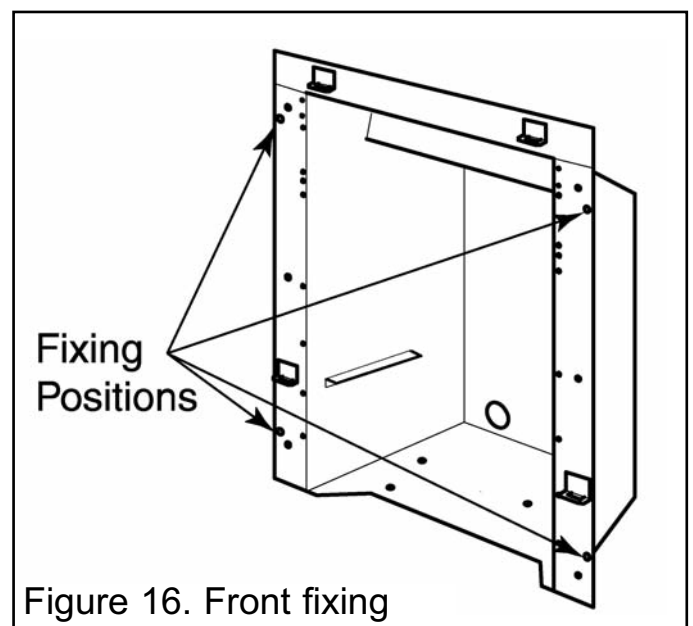

INSTALLER GUIDE

10.2 Method 2 - Cable retention and floor fixing.

1. Make sure that the relevant areas at the fireplace back or floor are sound enough to take the eyebolts and screws. If these areas have deteriorated due to prolonged use they should be made sound with suitable cement.

2. Drill four holes in the rear wall of the fireplace for the fibre plugs. The holes should be drilled within the range of positions shown in figure 17 using a suitably sized masonry drill for the fibre plugs supplied. The holes should be equidistant each side of the centre line of the fireplace to ensure that the appliance finishes centrally in the opening when tension is applied to the cables.

3. Insert a fibre plug into each hole. Use the fibre plugs supplied with this appliance - **Never use plastic plugs instead of the fibre plugs supplied.**

Screw the eyebolts into the plugs. Make sure that the bolts are secure.

4. Place the hotbox unit close to the fireplace but allow sufficient access into the fireplace opening so that the cables can be threaded through the eyebolts and returned through the back of the hotbox. If a concealed connection is being used, insert the hotbox into the fireplace feeding the supply pipe through the pierced hole in the rear grommet.

5. The hotbox has two holes at each side of the spillage plate. Insert one end of each cable (one cable each side) from the back through the lower of the two holes and return the end through the upper of the holes (See figure 18). Give the cables a pull so that they grip against the hotbox flanges.

6. Thread the cables through the eyebolts. Return the cables through the holes near the bottom of the hotbox back panel (See figure 19) (**For precast or clay block flue systems return the cables through the slotted holes in the side of the hotbox.**)

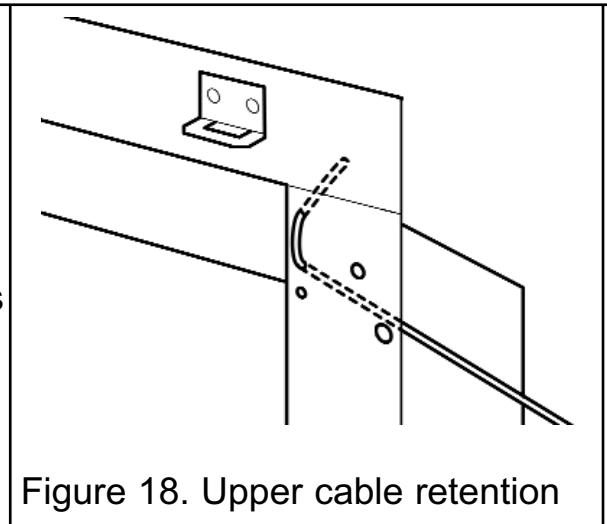
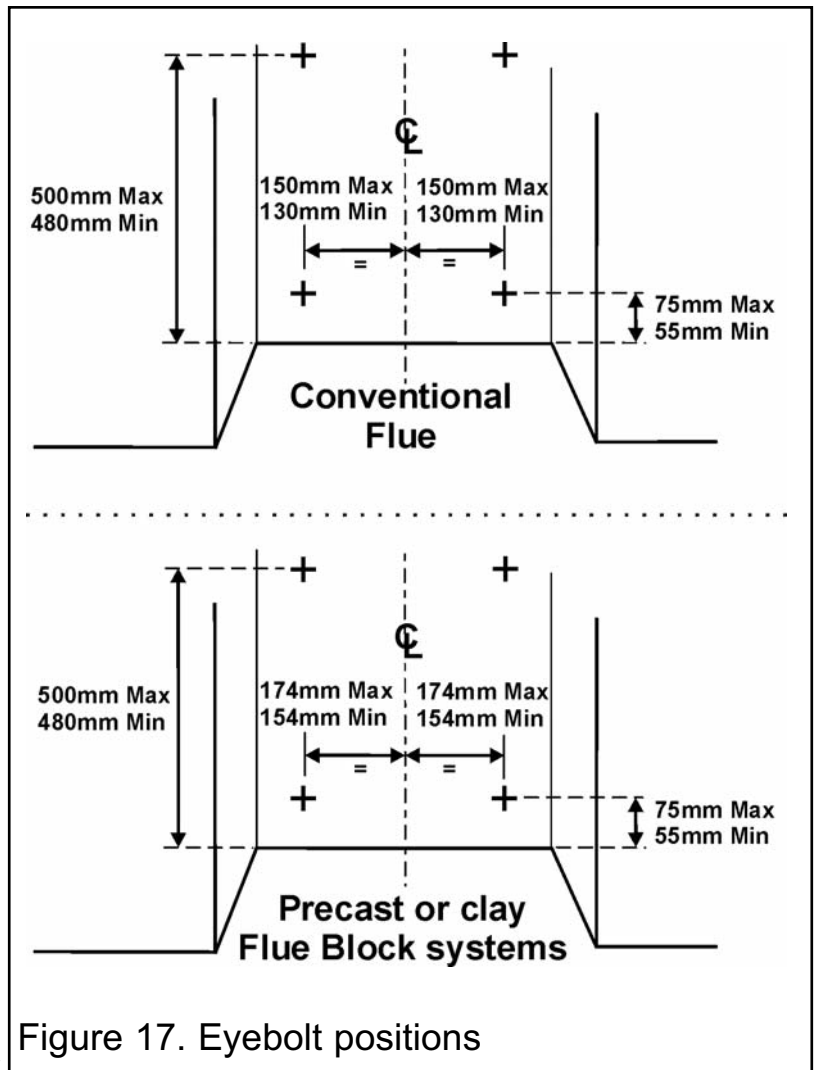

INSTALLER GUIDE

7. Place the hotbox fully back into the fireplace opening so that it is sealed against the fireplace front surround.
8. Drill a hole into the fireplace floor through each of the two holes in the base of the hotbox using a suitably sized masonry drill for the fibre plugs supplied (See figure 20).
9. Insert a fibre plug into each hole. Use the fibre plugs supplied with this appliance - **Never use plastic plugs instead of the fibre plugs supplied.** Fit a woodscrew in each plug and tighten.

Always screw the base into position before applying tension to the cables. This will ensure a tight seal between the top of the hotbox and wall

10. Fit a cable retainer over the bottom end of each cable.
11. Pull each cable taut. Push the cable retainers hard up against the back panel. The end of the cable adjuster will pass into the hole. Tighten the screws in the retainers so that they clamp the cables in position. Apply tension to the cables by turning the hexagonal adjusters by hand (See figure 21).
12. Inspect the installation of the hotbox against the fireplace surround. If the hotbox is aligned squarely and the sealing is satisfactory, fully tighten the cable retainers.

13. If the hotbox is not correctly aligned, release the tension on the cables by slackening the screws and turning the hexagonal adjusters fully anticlockwise. The hotbox should then automatically realign itself. Pull each cable taut again and push the cable retainers back against the back panel. Again, tighten the screws in the retainers and apply tension to the cables by turning the hexagonal adjusters clockwise as far as possible.

14. Feed the free length of the cables into the gap between the inner and outer back panels so that they are available to allow easy removal and refitting of the appliance during subsequent service calls. **Do not cut off the free lengths of cable.** On precast flue installations feed the cables into the small holes at the base of the side panels.

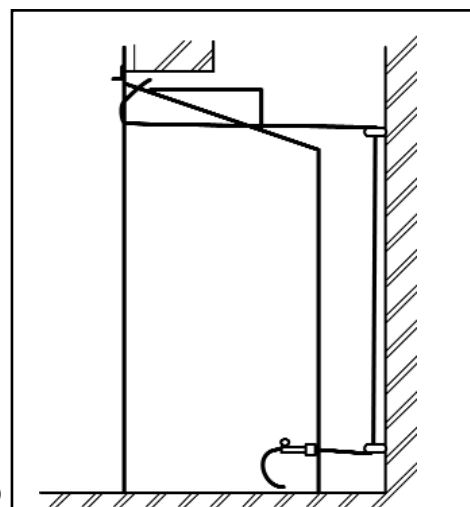

Figure 19. Cable route

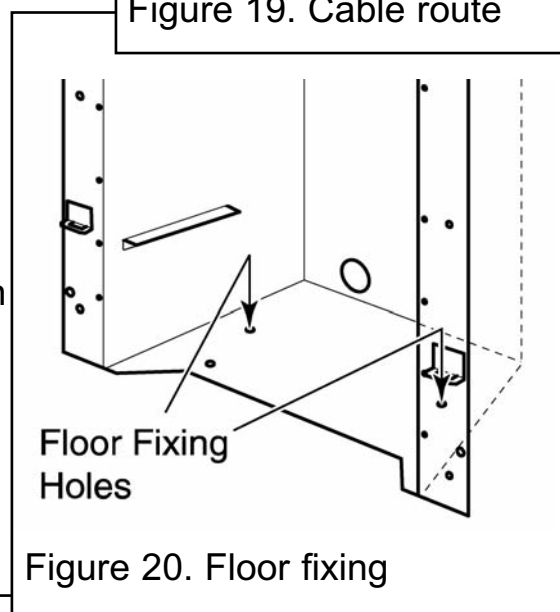

Figure 20. Floor fixing

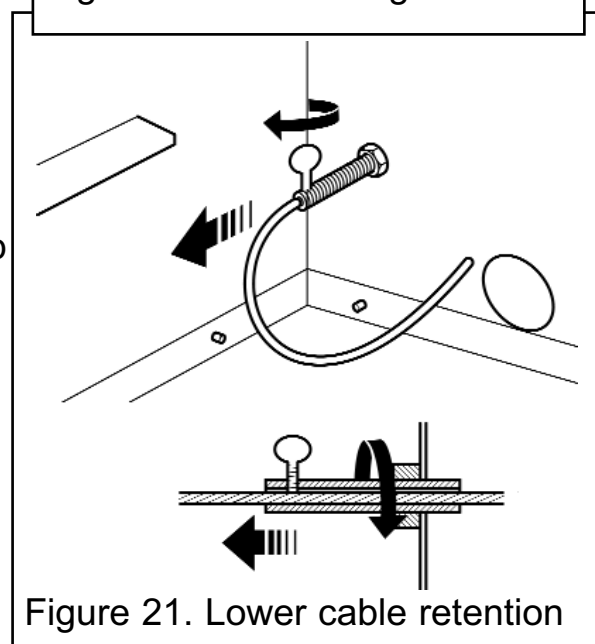

Figure 21. Lower cable retention

INSTALLER GUIDE

10.3 Sealing floor front - all installations.

Using the floor sealing tape supplied, seal the bottom of the hotbox to the fireplace and hearth floor (See figure 22).

Make sure that the whole length of the front edge of the hotbox is fully sealed.

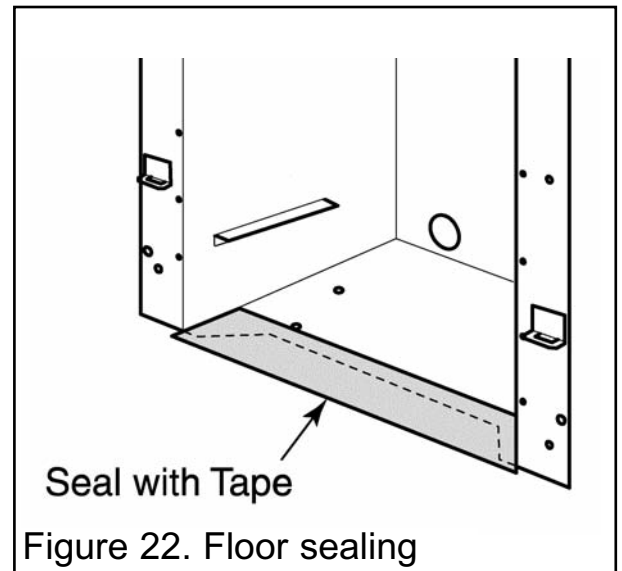

11. BURNER & SUPPLY PIPE INSTALLATION

11.1 Fitting the burner.

1. Place the burner module into the hotbox.
2. Refit the burner cover by lowering it onto the burner module. The front edge of the burner cover should locate in front of the burner module. The sides of the burner cover should locate behind the front of the burner module. Secure with two screws removed previously (See figure 23)
3. Refit the Inner Reflector into the hotbox. Be careful not to scratch the top surface of the burner cover. Secure using six screws removed previously.
4. Refit the spillage plate. Secure using the four screws removed previously.

11.2 Supply pipe installation.

A nut and olive is provided for an 8mm-pipe inlet connection directly to the gas control. The isolating 'T' connector can be rotated to allow a connection from any direction. The 'T' connector includes a valve for isolating the gas supply.

The supply pipe must be rigid material. Flexible pipe must not be used. Connect the supply line to the appliance.

Turn on the gas supply and pressure check the installation pipework for gas soundness. In the United Kingdom (GB) check in accordance with the current edition of BS 6891. In the Republic of Ireland check in accordance with the current edition of IS 813 "Domestic Gas Installations".

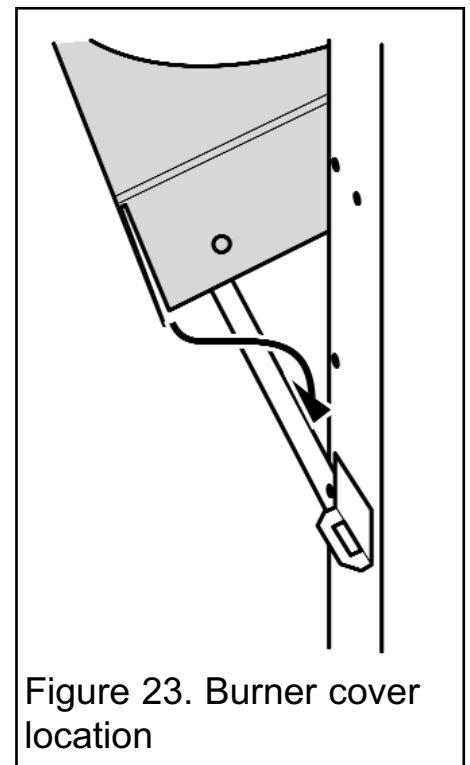

INSTALLER GUIDE

11.3 Preliminary burner checks.

Some burner operations can be checked at this stage. Checking now will mean that less disassembly will be required if any problems are found. ***A full check should still be made, however, after final installation.***

11.3.1 Lighting the fire.

If closed, open the isolating 'T' connector valve. Depress the control knob and rotate it anticlockwise to the pilot ignition position. A 'click' will be heard as the integral piezo operates. A spark should be seen between the electrode and pilot tip. Turn the control knob clockwise to the 'Off' position. Repeat this operation until a flame appears at the pilot. There may be a delay before the pilot lights due to air being purged from the system. When a flame appears at the pilot keep the control knob depressed and hold the pilot ignition position for five seconds. When the control knob is released the pilot flame should remain lit.

If there are no sparks check that the electrode lead is connected to the electrode tag.

11.3.2 Operating the burner.

When the pilot burner is operating properly, gradually turn the control knob anticlockwise to 'HIGH' (Depress the knob slightly to get past the pilot ignition position). The main burner should now light. Depress the control knob slightly to release from the 'HIGH' position and turn back (clockwise) to 'LOW'. While turning, the burner flames should gradually become lower but remain alight. Depress the control knob slightly to release from the 'LOW' position and turn back (clockwise) to the Pilot ignition position. The main burner should extinguish but the pilot should remain alight. Depress the control knob slightly and turn back (clockwise) to turn OFF.

This will extinguish the pilot.

11.4 Check inlet pressure.

The appliance is pre-set to give the correct heat input at the inlet pressure shown in section 2 of this manual. No adjustment is necessary.

1. Check the inlet pressure by fitting a pressure gauge at the test point. The test point is on the inlet 'T' connector (See figure 24). Check the pressure with the appliance alight and set at maximum output.

2. After checking, turn off the appliance. Remove the pressure gauge and replace the test point sealing screw.

3. Relight the appliance. Turn to the maximum output position and test around the sealing screw for gas soundness with a suitable leak detection fluid.

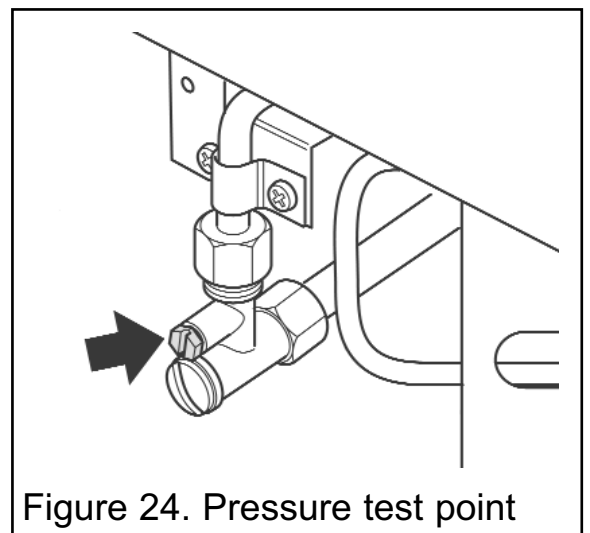

Figure 24. Pressure test point

INSTALLER GUIDE

11.5 Fitting the lower hotbox baffle to the 'Fascination' model.

The lower hotbox baffle is supplied for use when fitting the 'Fascination' model into elevated builders openings or 'Hole in the wall' installations.

1. Locate the baffle as in figure 25.
2. Secure the baffle using the screw supplied.

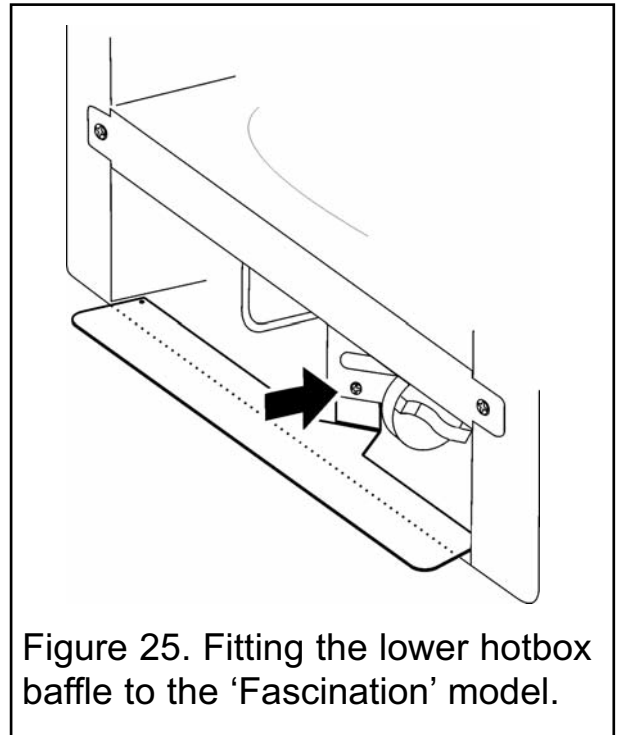

Figure 25. Fitting the lower hotbox baffle to the 'Fascination' model.

12. FITTING THE CERAMIC FUEL EFFECT

The installer and owner guide for the ceramic fuel effect is supplied with the ceramic fuel effect. It is important that the guide for the ceramic fuel effect be placed inside or attached to this guide and handed to the customer following completion of the 'final review' section.

13. FULL OPERATING CHECKS

13.1 Check the control settings.

Please note:

When first turned on from cold, the flames will appear predominantly blue.

When operating the fire for the first time, some vapours may be given off which could set off smoke alarms in the vicinity. These vapours are quite normal with new appliances. They are totally harmless and will disappear after a few hours use.

13.1.1 Lighting the burner.

Open the isolating valve on the 'T' connector. Screw on the end cap and test for leaks.

Depress the control knob and rotate it anticlockwise to the pilot ignition position. A 'click' will be heard as the integral piezo operates. A flame should appear at the pilot to the left hand side of the ceramic fuel effect. When a flame appears at the pilot keep the control knob depressed and hold the pilot ignition position for five seconds. When the control knob is released the pilot flame should remain lit.

If there are no sparks check the spark gap between electrode wire and pilot tip.

INSTALLER GUIDE

13.1.2 Operating the burner.

Turn the control knob anti-clockwise to 'HIGH' (Depress the knob slightly to get past the pilot ignition position). The main burner should now light. Depress the control knob slightly to release from the 'HIGH' position and turn back (clockwise) to 'LOW'. While turning, the burner flames should gradually become lower but remain alight. Depress the control knob slightly to release from the 'LOW' position and turn back (clockwise) to the Pilot ignition position. The main burner should extinguish but the pilot should remain alight. Depress the control knob slightly and turn back (clockwise) to turn OFF. This will extinguish the pilot.

13.2 Check for spillage.

A spillage check must be made before leaving the installed appliance with the customer. Make this with all the ceramic fuel effect pieces in position.

1. Close all doors and windows in the room containing the appliance.
2. Light the appliance and set the control to the 'High' position.
3. Leave the appliance on for five minutes.
4. The smoke match should be placed horizontally into the hotbox at the right hand side (See figure 26).

The installation is satisfactory if the smoke is drawn into the appliance.

If the smoke is not drawn into the appliance leave the appliance alight at the maximum setting for a further ten minutes and then repeat the test. If the smoke is still not drawn into the appliance inspect the sealing to the fireplace surround. If the sealing is satisfactory but the appliance is installed with the flue restrictor (See section 9 point 14) remove the restrictor, reseal the appliance and retest. If smoke is still not drawn into the appliance **disconnect the appliance and seek expert advice.**

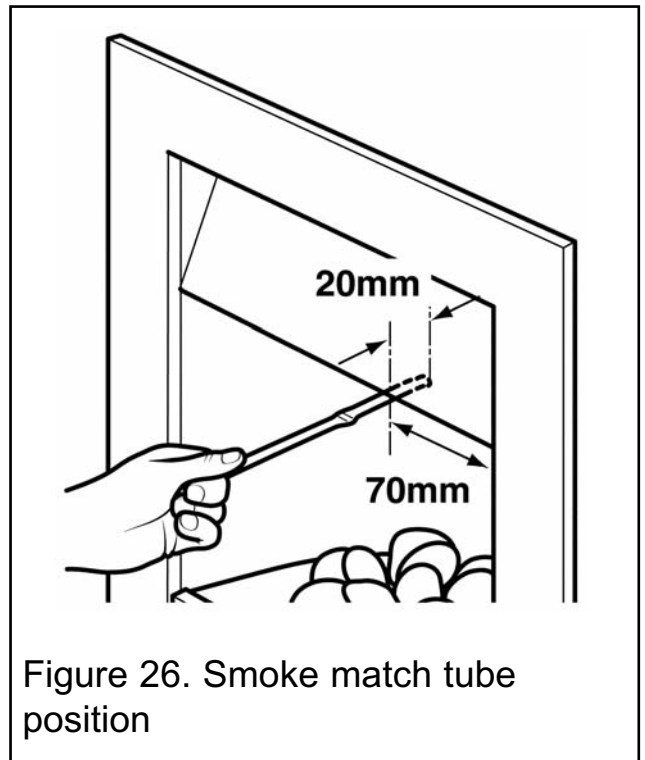

Figure 26. Smoke match tube position

5. If the above test is satisfactory open all internal connecting doors, hatches, etc. in the room. Keep all doors and windows that open to the outside of the building closed. Recheck for spillage as above. If an extractor fan is installed in the same room as the appliance or a connecting room, check that spillage does not occur with the fan operating and all doors and other openings between the fan and the appliance open. If the smoke is drawn into the appliance, continue with the installation. If the test is not satisfactory **disconnect the appliance and advise the customer of the cause of failure.**

INSTALLER GUIDE

13.3 Flame supervision and spillage monitoring system.

This pilot unit includes a system that will automatically shut off the gas supply if the pilot flame goes out or if there is insufficient oxygen due to spillage or poor ventilation. Check that the system operates properly as follows: -

- Light the appliance. Set at the “HIGH” position and leave for one minute.
- Turn back to “OFF” to extinguish the pilot. **Note the time when the pilot goes out.** Listen for a snap sound at the gas tap. **Note the time when the sound is heard.** This sound is caused by an electromagnetic valve shutting off the gas supply through the tap. The valve is located in the body of the tap. The valve should operate **within 60 seconds of the pilot going out.** If the valve does not operate within this time limit do not allow the appliance to be used until the fault has been corrected. **This monitoring system must not be adjusted, bypassed or put out of operation.**

This monitoring system or any of its parts must only be exchanged using Valor Fires authorised parts.

14. FASCIA INSTALLATION

14.1 Fitting the Eclipse fascia.

1. Remove any protective film from the fascia.
2. Carefully lift the fascia. Place the fascia against the fireplace front surface so that the four retaining plates at the back of the fascia are directly above the four retaining brackets of the hotbox. There are two at the top of the hotbox and two to the side of the burner module. Lower the fascia unit making sure that the retaining plates locate fully into the brackets on the hotbox (See figure 27).

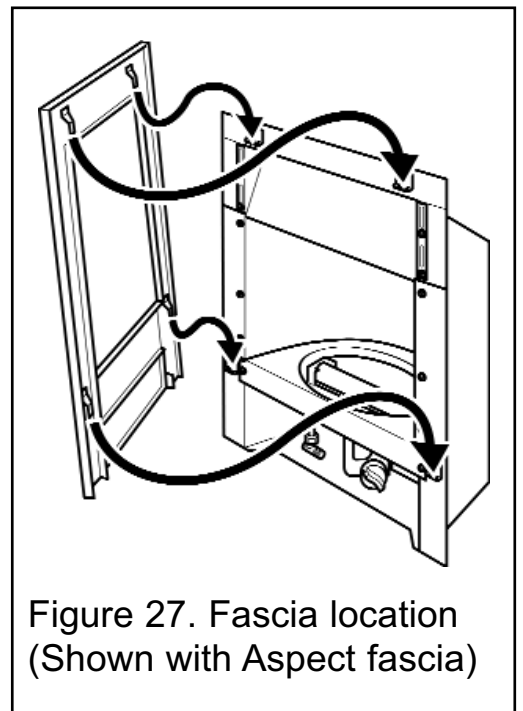

Figure 27. Fascia location
(Shown with Aspect fascia)

INSTALLER GUIDE

3. The fascia decorative trim is made up of four sections. A bottom and top section of equal length and two shorter sections of equal length that are the side sections. These can be identified as in figure 28.

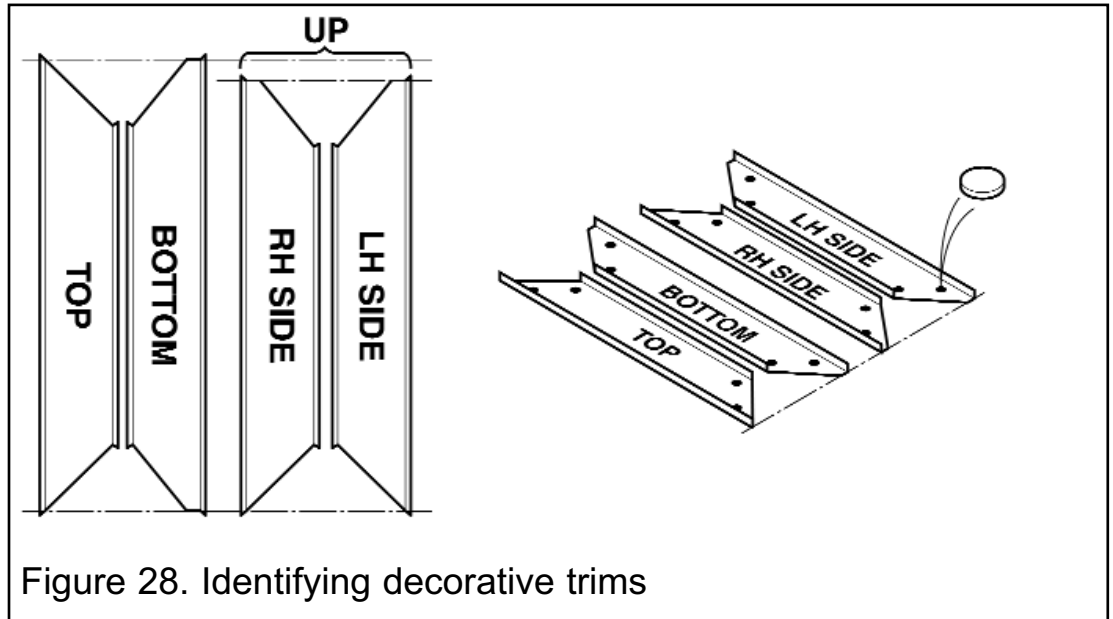

Figure 28. Identifying decorative trims

4. Remove any

protective film from the trim sections

5. The trim sections are held in place using 16 magnets. Position the magnets as in figure 28.

The order in which the trims are fitted is important.

6. Locate the bottom trim as in figure 29.

7. Locate the two side trims as in figure 30.

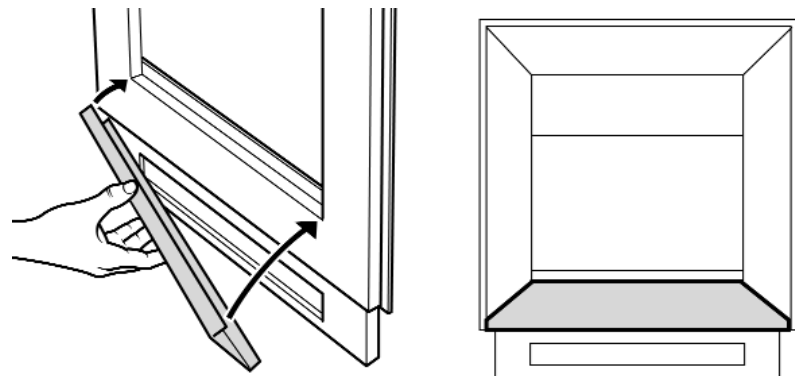

Figure 29 Fitting the bottom trim.

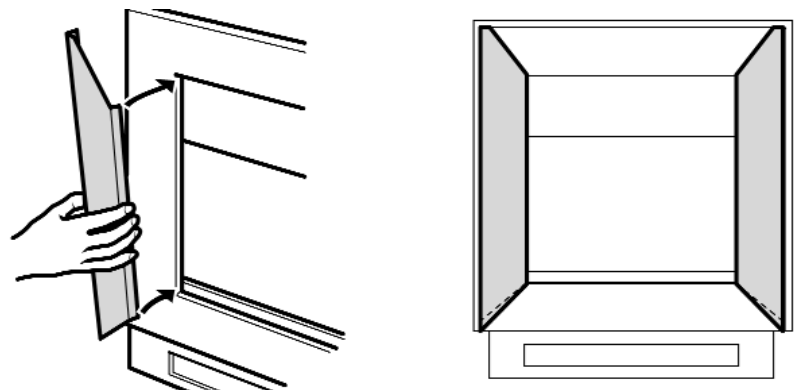
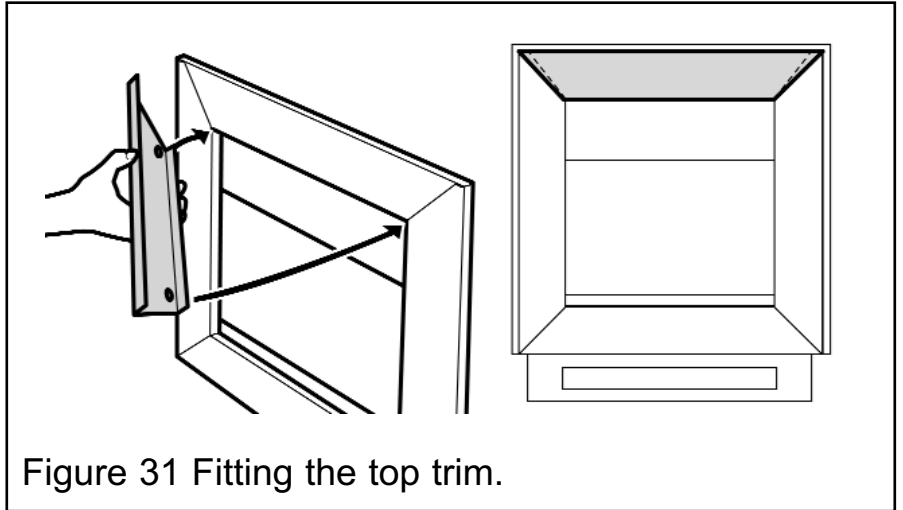

Figure 30 Fitting the side trims.

INSTALLER GUIDE

8. Locate the top trim as in figure 31.



14.2 Fitting the Landscape, Visia and Serenity fascia.

1. Supplied with the fire are two fascia securing brackets and two machine screws. Secure the brackets to the hotbox using the machine screws supplied (See figure 32).

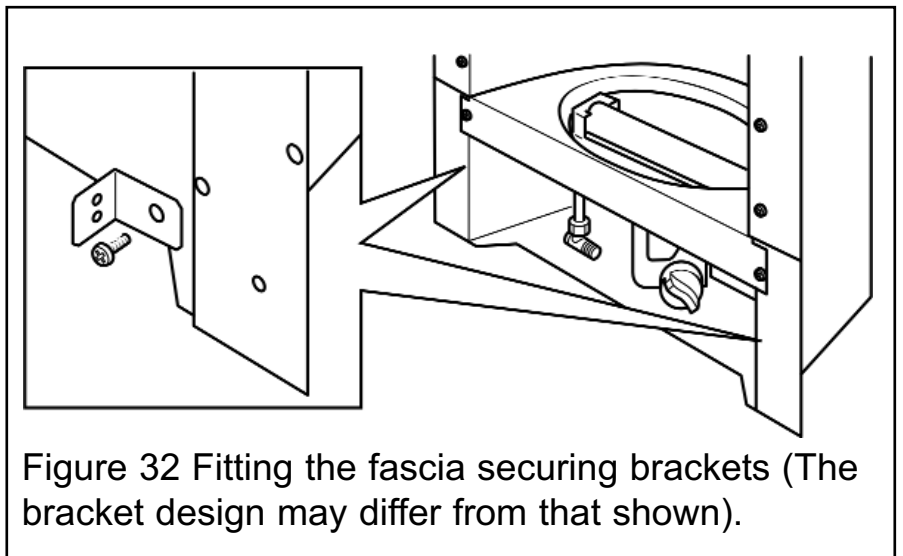

2. Insert two black self tapping screws into the holes at the top of the spillage plate leaving about 1.5mm gap between the underside of the screw head and the spillage plate (See figure 33)

3. At the top of the fascia there are two cut-outs. Locate the cut-outs on to the screws at the top of the spillage plate (See figure 34).

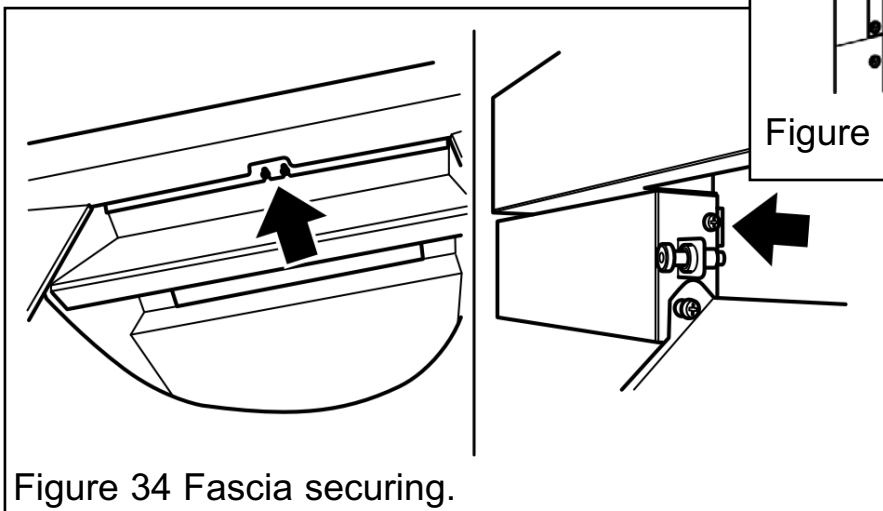
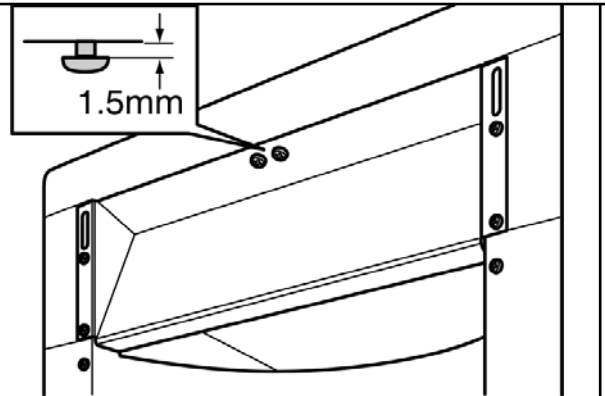

INSTALLER GUIDE

4. The lower inner sides of the fascia should sit on top of the fascia securing brackets. The fascia will need to be re-positioned if the fascia sides fall behind the brackets (See figure 34). Secure the fascia using two self tapping screws supplied (See figure 34)

5. Tighten the two screws in the top of the fascia.

6. *Serenity model only* - Where fitted, remove the protective film from the fascia trims.

6. *Visia model only* - Supplied with the fire is a heat baffle. This baffle must be fitted to the underside of the spillage hood.

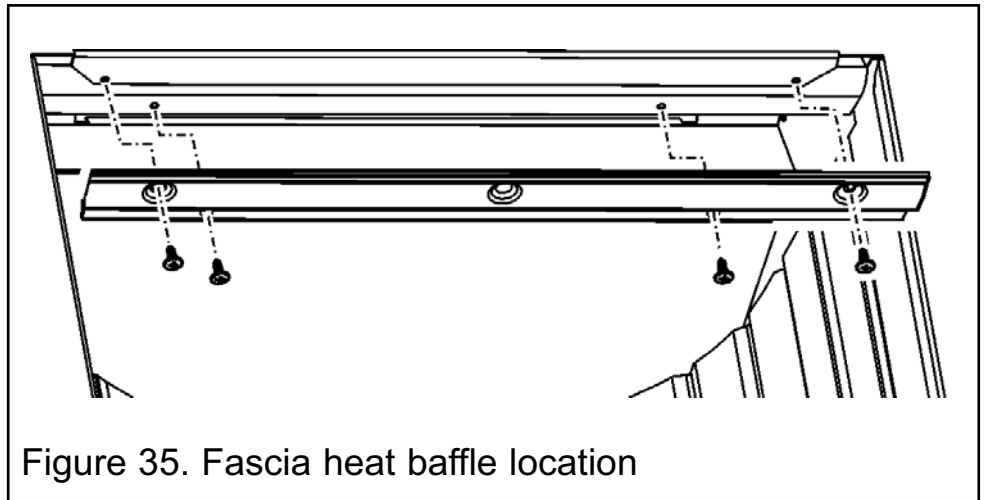

Figure 35. Fascia heat baffle location

● Secure the baffle to the underside of the spillage hood using the two screws supplied (See figure 35). The centre hole does not require a screw.

14.3 Fitting the trims to the Fascination fascia.

1. Remove any protective film from the fascia.

2. Lay the fascia frame on a flat surface with its front facing up.

3. The fascia decorative trim is made up of four sections. A bottom and top section of equal length and two shorter sections of equal length that are the side sections. These can be identified as in figure 36.

4. Remove any protective film from the trim sections

5. Locate the side trims as in figure 37.

6. Locate the bottom and top trims as in figure 38.

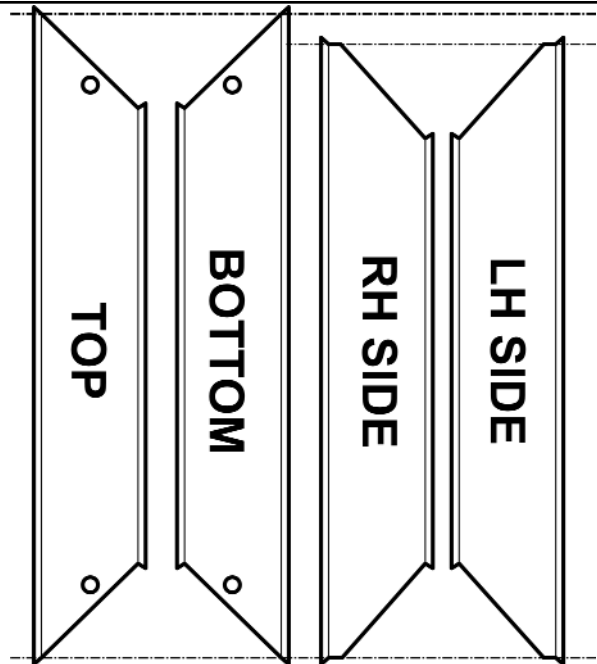

Figure 36. Identifying decorative trims

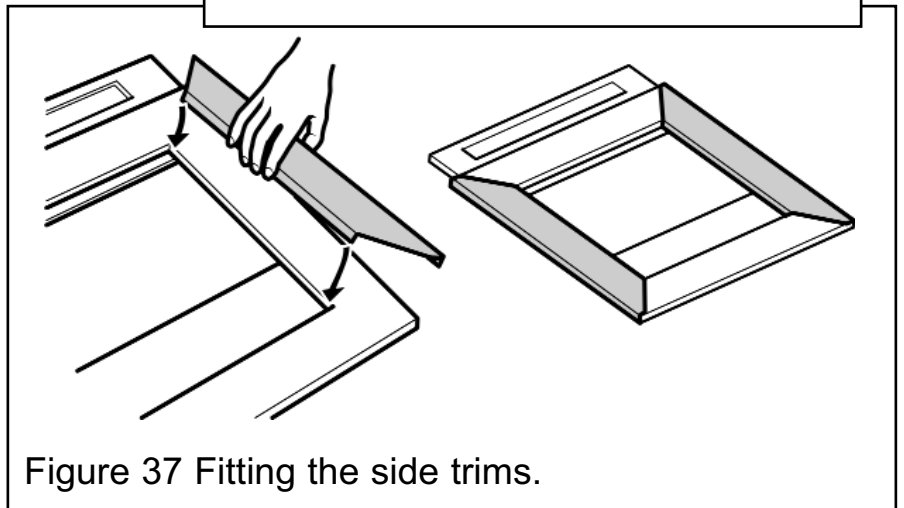
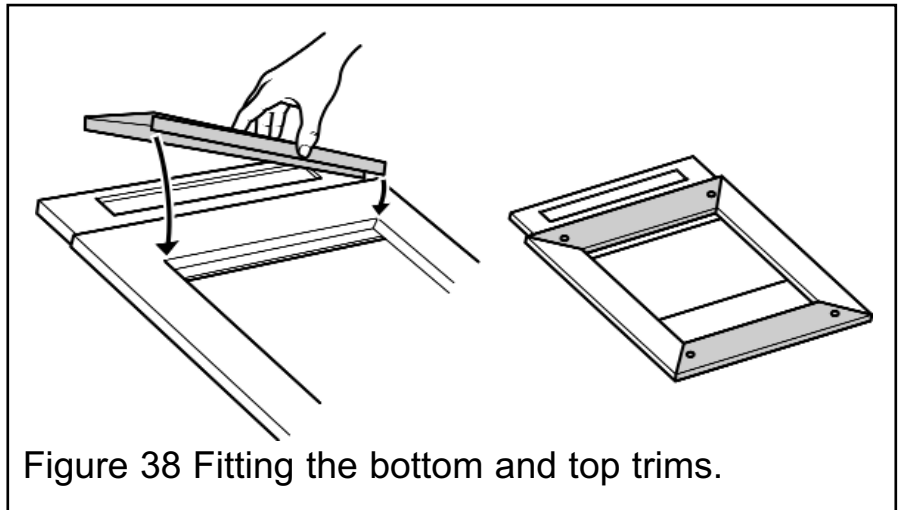

Figure 37 Fitting the side trims.

INSTALLER GUIDE



14.4 Fitting the Glass panel to the 'Fascination', 'Tranquility' and 'Aspect Glass' fascia (See figure 39).

1. Supplied with the trim pack are four cylindrical spacers and four screws to secure them in place. On the 'Fascination' model the spacers also secure the fascia trims in place. Place the spacers over the holes in the trim / fascia. Secure in place with the screws supplied (Do not use the mirror screws as these are for the front of the fascia. These have a

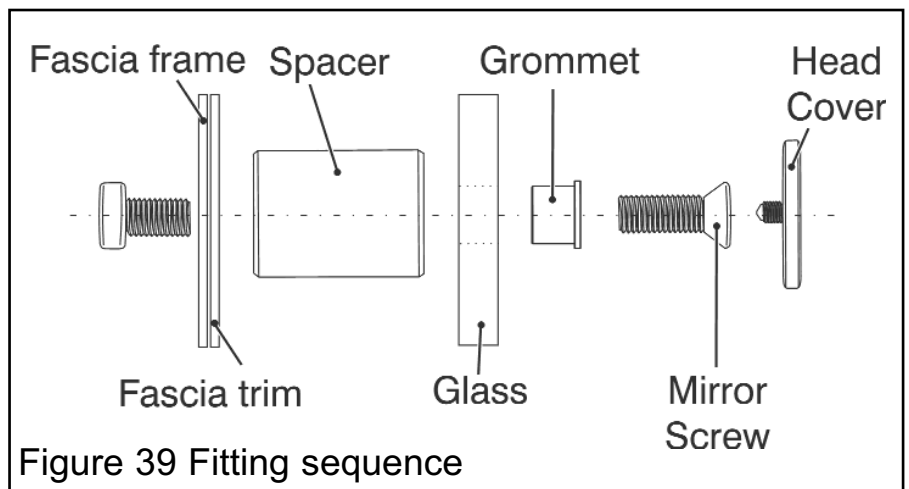

countersunk head that has a threaded hole in the centre).

2. Ensure that the fascia is layed on a flat surface with its front facing up. Carefully unpack the fascia glass panel.

3. Locate the glass panel onto the spacers. Align the holes in the glass with the spacers.

4. Supplied with the trim pack are four nylon grommets. Locate a nylon grommet into each hole in the glass panel.

5. Supplied with the trim pack are four 'mirror' screws. These have a countersunk head that has a threaded hole in the centre. Secure the glass panel in place with the four 'mirror' screws supplied.

Important - Do not over tighten the screws. The screws only need to be tightened sufficiently to retain the glass panel. Excess pressure may cause the glass panel to break, for this reason we recommend the use of a suitably sized coin or washer to tighten the mirror screws in place of a screwdriver.

6. Supplied with the trim pack are four head covers for the 'mirror' screws. Locate these by placing onto the heads of the 'mirror' screws and turning clockwise.

INSTALLER GUIDE

Important: The spacers provided with the trim pack must always be fitted. Never reduce the depth of the spacers in any way. Always replace the spacers with authorised spares (See figure 40).

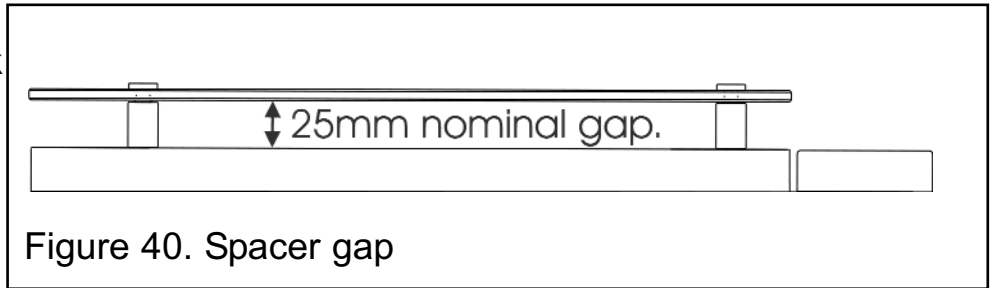

14.5 Fitting the Amour, Tranquility, Aspect and Aspect Glass fascia.

1. Remove any protective film from the fascia.
2. Carefully lift the fascia.

Place the fascia against the fireplace front surface so that the four retaining plates at the back of the fascia are directly above the four retaining brackets of the hotbox. There are two at the top of the hotbox and two to the side of the burner module. Lower the fascia unit making sure that the retaining plates locate fully into the brackets on the hotbox (See figure 41).

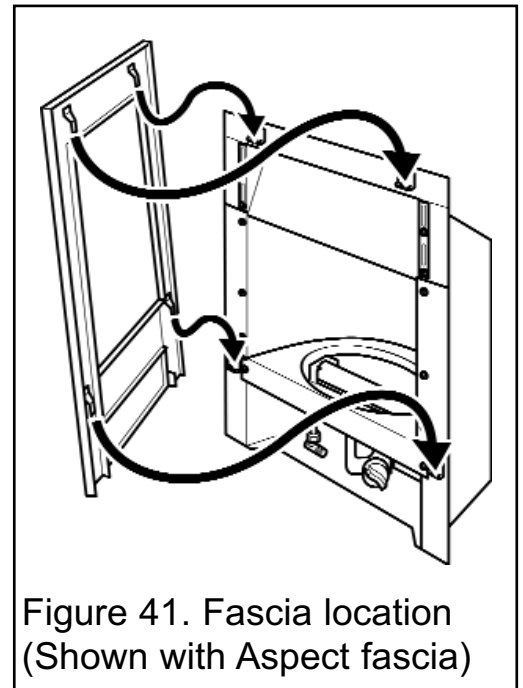

15. FINAL REVIEW

1. COMPLETE THE INFORMATION IN THE WARRANTY AND SERVICE SECTION OF THE OWNER GUIDE (See last pages of the OWNER guide).
2. Visually inspect the appliance. Clean off any marks incurred during installation. The fire should be 'off' and allowed to cool completely before cleaning.

Metal parts.

- Clean the metal parts with a slightly damp lint free non-abrasive cloth and then dry.
- Do not use abrasive cleaners as these will scratch the fire surface.
- **Fascia** - Clean the metal parts with a slightly damp cloth and then dry. If this does not work apply a very small amount of 'baby oil' to a lint free non-abrasive cloth and wipe over the surface. Use a clean cloth to wipe off the oil.

Glass parts.

- Marks and stains on the glass can be removed using non-abrasive glass cleaner. Non-abrasive ceramic hob cleaner can be used to remove stains.

INSTALLER GUIDE

3. Advise the customer how to operate the appliance. Point out that lighting instruction details are on the metal plate attached at the bottom of the appliance. Explain to the customer that the appliance has a flame failure & spillage monitoring system. Point out the explanation of this system shown in the owner guide under “Operating the fire”. Advise that if the fire goes out for any reason; wait at least three minutes before relighting. Stress that if the monitoring system repeatedly shuts off the fire, the appliance should be switched off and a specialist should be consulted.
4. Advise the customer that they should read their owner guide before operating the fire and always follow the advice in the section headed “Cleaning your fire”.
5. **Stress that no extra fuel effect pieces must be added over and above those supplied with the appliance and that any replacements must only be the authorised spares. Warn that ignoring this advice could cause incomplete clearance of the products of combustion with consequent health hazards.**
6. Advise the customer that the appliance will operate to its maximum potential if the flue is primed during the first 20 – 30 minutes of use. To do this, simply turn the control to its ‘HIGH’ setting. This will also burn off any carbon deposits that may have formed during previous use.
If using the appliance for long periods it is beneficial to change between settings. This will also help to remove any carbon deposits that may form during use.
7. Recommend that the appliance should be serviced by a competent person at least annually.
8. If the appliance is in premises in the United Kingdom occupied by a tenant, point out that by law a landlord must have any gas appliance, flue and pipework which is situated in a tenant’s premises checked for safety at least every 12 months.
9. Advise that the fire may give off a slight odour while new. This is quite normal and it will disappear after a short period of use.
10. **Inform the customer that the Serial number for the appliance is located on the information label located behind the lower cover and attached underneath the burner module.**
11. Hand the literature pack with this guide to the customer.

16. SERVICING & PARTS REPLACEMENT

- Always turn off the gas supply before commencing any servicing (The appliance inlet “T” connector incorporates an isolating valve).
- It is recommended that, at least once a year, the appliance is disconnected and the fireplace opening checked and cleared of any debris.
- This product uses fuel effect pieces containing Refractory Ceramic Fibres (RCF), which are man-made vitreous silicate fibres. Excessive exposure to these materials may cause irritation to eyes, skin and respiratory tract. Consequently, it is important to take care when handling these articles to ensure that the release of dust is kept to a minimum. To ensure that the release of fibres from these RCF articles is kept to a minimum, during installation and servicing we recommend that you use a HEPA filtered vacuum to remove any dust and soot accumulated in and around the fire before and after working on the fire. When replacing these articles we recommend that the replaced items are not broken up, but are sealed within a heavy duty polythene bag, clearly labelled as RCF waste. RCF waste is classed as a stable, non-reactive hazardous waste and may be disposed at a landfill licensed to accept such waste. Protective clothing is not required when handling these articles, but we recommend you follow the normal hygiene rules of not smoking, eating or drinking in the work area and always wash your hands before eating or drinking.
- Check that the appliance is clean and that soot or debris is not blocking the gaps between the ceramic fuel effect pieces causing an imperfect flame.
- Check that soot or debris is not impairing the electrode spark or pilot burner.
- Check that soot or debris is not blocking any of the holes in the main burner.
- After servicing, make sure that the ceramic fuel effect pieces are replaced correctly as described in the installation instructions.
- **Always test for gas soundness and spillage after servicing the appliance.**

INSTALLER GUIDE

16.1 To remove the fascia.

(Amour, Aspect, Aspect Glass, Eclipse, Tranquility and Fascination models).

- 1. Eclipse model only-** Remove the upper fascia trim, side fascia trims and lower fascia trim. These are held by magnets.
2. The fascia is held in place by four retaining plates at the back of the fascia. These slot into four retaining brackets on the hotbox. To remove the fascia, hold the sides of the fascia and lift upward and forward. The fascia should lift clear of the hotbox (See figure 42).
3. Replace in the reverse order.

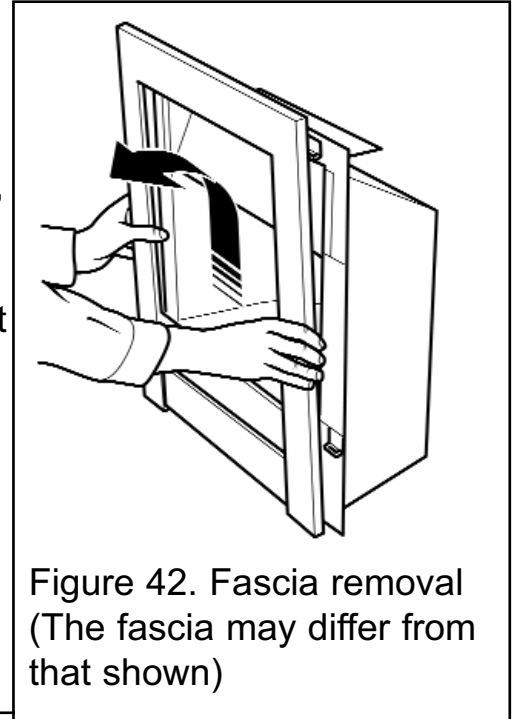

Figure 42. Fascia removal
(The fascia may differ from that shown)

(Landscape, Visia and Serenity models).

1. Visia model only.
There is a heat baffle that is screwed to the fascia and spillage plate (See figure 43). Unscrew and remove this heat baffle.

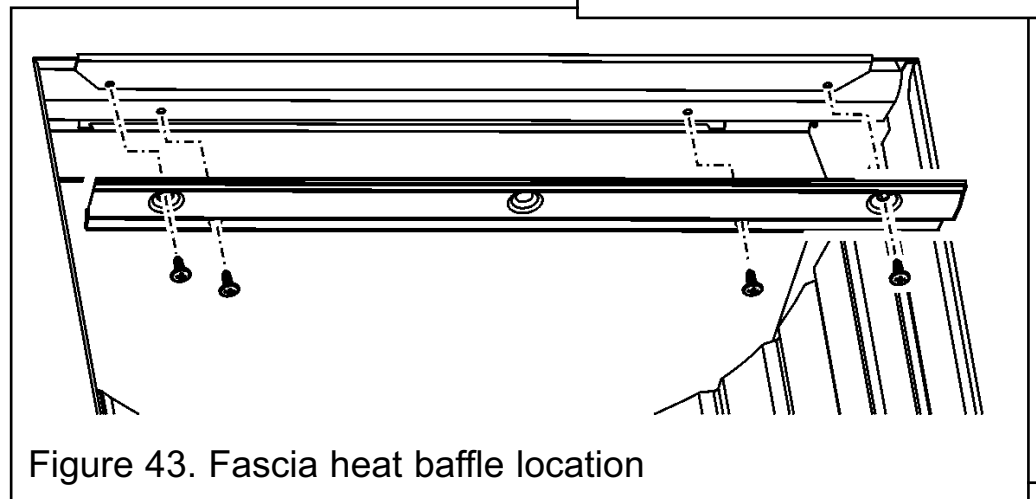

Figure 43. Fascia heat baffle location

2. Remove the two screws from the base of the fascia (See figure 44).

3. Support the fascia and release the two screws from the top of the spillage plate. Do not remove the screws but release them sufficiently to allow the fascia to be lifted off. Lift the fascia clear of the hotbox.

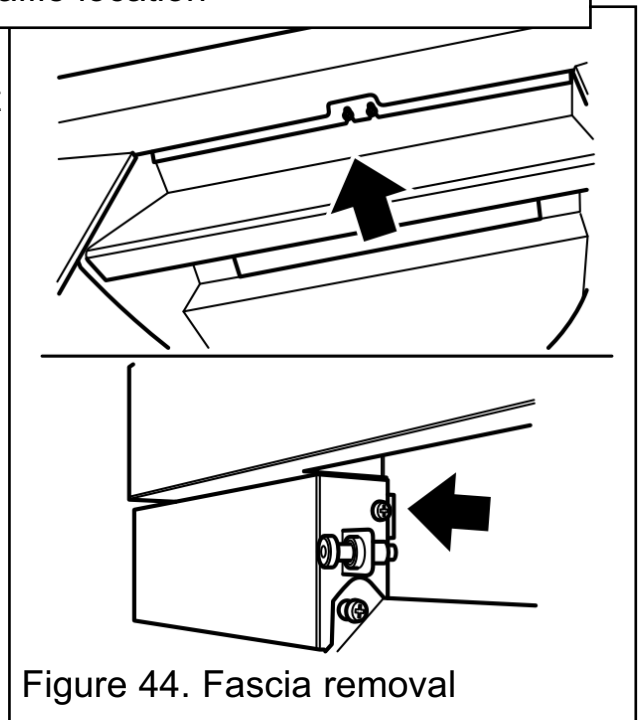

Figure 44. Fascia removal

INSTALLER GUIDE

16.2 To remove the burner unit.

1. Remove the fascia as in section 16.1.
2. Remove the ceramic fuel effect pieces.
3. Detach the spillage plate from the hotbox by removing the four screws (See figure 45). Place the spillage plate in a safe place away from the work area.
4. Remove the six screws from the side of the inner reflector (See figure 46).
5. Carefully lift the inner reflector and pull forward to remove.

Be careful not to scratch the top surface of the burner cover. Place the inner reflector in a safe place away from the work area.

6. Remove the two screws to the side of the burner cover (See figure 47)
7. Detach the burner cover by lifting clear of the burner module (See figure 47). Place the burner cover in a safe place away from the work area.
8. Isolate the gas supply at the inlet isolating 'T' connector
9. Support the inlet 'T' connector to avoid straining the pipework and disconnect the appliance from the inlet 'T' connector.
10. Detach the burner unit from the hotbox by lifting clear
11. Replace in the reverse order.

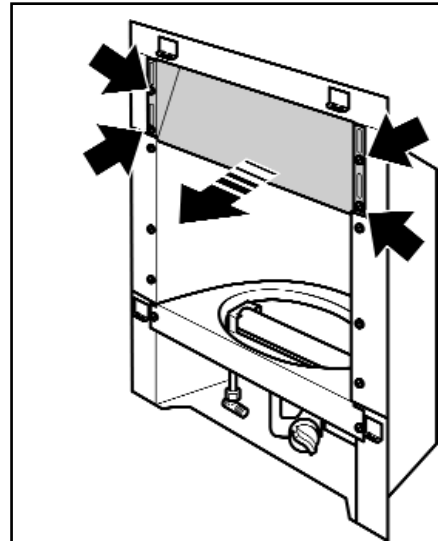

Figure 45. Spillage plate removal

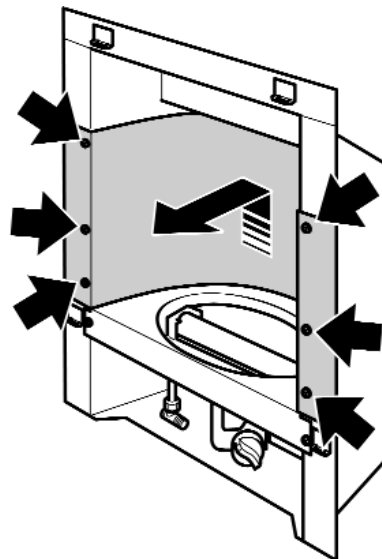

Figure 46. Removal of inner reflector

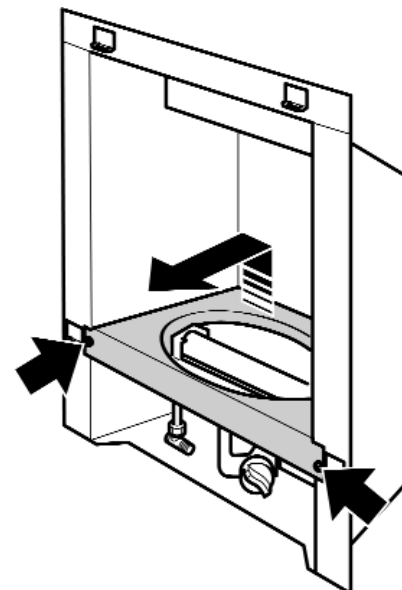

Figure 47. Removal of burner module

INSTALLER GUIDE

16.3 To remove the pilot unit.

1. Remove the burner unit (See section 16.2).
2. If lying the burner on its back, ensure that the work surface is suitably protected. This will avoid damage to the work surface. Detach the pilot pipe from the pilot unit.
3. Detach the thermocouple from the gas valve.
4. Detach the electrode lead from the underside of the electrode tab.
6. Remove the two screws securing the pilot unit (See figure 48).
7. Refit in the reverse order.

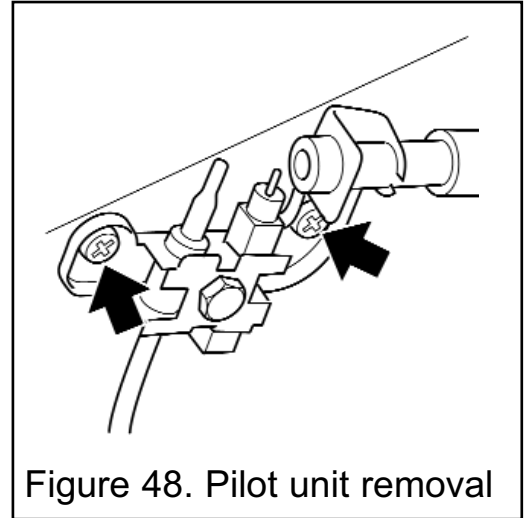

Figure 48. Pilot unit removal

Note: 1. The pilot unit is an atmosphere sensing device. It must be replaced as a whole assembly. Its individual components are not separately replaceable.

16.4 To remove the gas valve.

(See figure 49).

1. Remove the burner unit (See section 16.2).
2. If lying the burner on its back, ensure that the work surface is suitably protected. This will avoid damage to the work surface. Turn the burner unit upside down. Detach the thermocouple from the tap.
3. Detach the pilot pipe from the tap.
4. Detach the inlet pipe.
5. Detach the injector pipe.
6. Detach the electrode lead from the base of the electrode.
7. Remove the control knob by pulling forward.
8. Unscrew and remove the control spindle extension (where fitted).
8. Remove the thermocouple by unscrewing the thermocouple nut at the gas valve.
9. Remove the hexagonal nut securing the gas valve to the mounting bracket.
10. Remove the gas valve.
11. Refit in the reverse order.

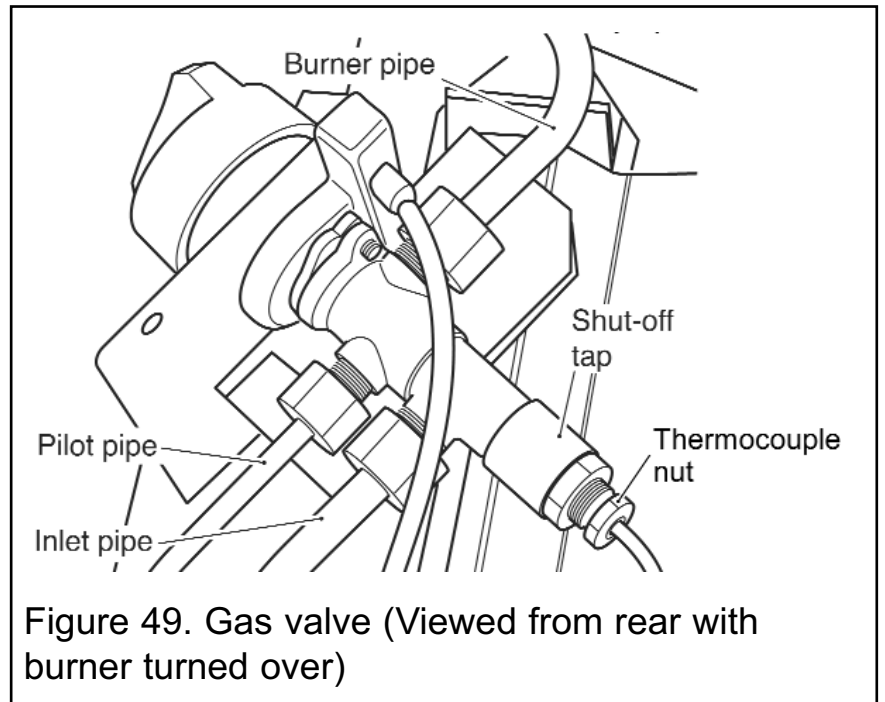

Figure 49. Gas valve (Viewed from rear with burner turned over)

INSTALLER GUIDE

16.5 To remove the piezo generator.

1. Remove the gas valve as section 16.4.
2. Make sure that the tap is in the off position.
3. Remove the circlip holding the piezo unit to the tap. Remove the piezo unit.
4. Replace in the reverse order.

16.6 To grease the control tap.

1. Detach the tap and remove the piezo generator as section 16.5 making sure that the tap is in the 'off' position.
2. Remove the two screws from the head of the tap. Remove the niting head and spindle complete with collar and spring.
3. Note the position of the slot in the plug - mark its position on the tap body.
4. Remove the plug rotating slightly while pulling.
5. Clean and grease the plug lightly with suitable grease. Do not apply excessive grease. Particularly, make sure that the gas ports in the tap are not restricted by grease.
6. Push the plug into the tap body and position the slot in line with the mark previously made on the tap body.
7. Reassemble the niting head and spindle complete with collar and spring making sure that the components are correctly engaged. Check the operation of the tap.
8. Refit the piezo generator.

16.7 To replace the burner.

(See figure 50).

1. Remove the burner unit (See section 16.2).
2. Support the elbow injector and unscrew the injector nut.
3. Remove the two screws from the burner clamping plate (See figure 50)
4. Lift the right hand side of the burner, slide it to the right and lift clear
5. Refit in reverse order.

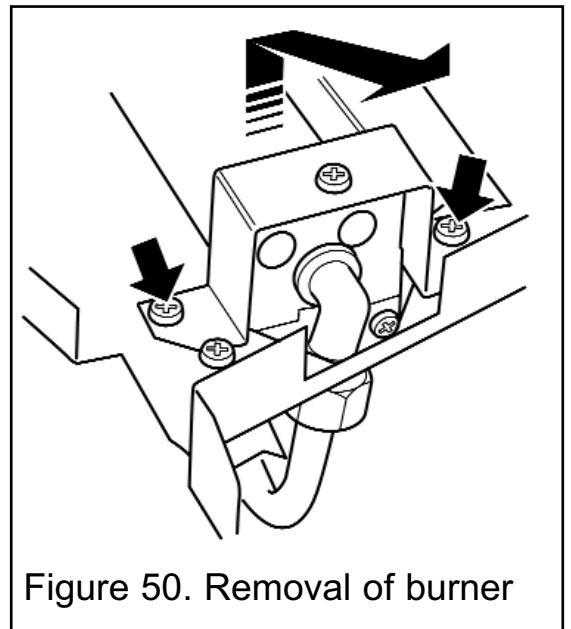

INSTALLER GUIDE

16.8 To remove the main burner injector.

(See figure 51).

1. Remove the burner (See section 16.7).
2. Remove the burner clamping screw (See figure 51)
3. Unscrew the injector from the burner.
4. Refit in the reverse order.

16.9 To remove the appliance from the fireplace.

1. Remove the burner unit (See section 16.2).
2. If the fire retention is as method 1 (See section 10.1 of installation instructions), remove the screws. If the fire retention is as method 2 (See section 10.2 of installation instructions), slacken the hexagonal adjusters on the cable retainers and unscrew the thumbscrews to release the cables.
3. Refit as described in the relevant installation sections. Make sure gas soundness, sealing, spillage test and performance are satisfactory.

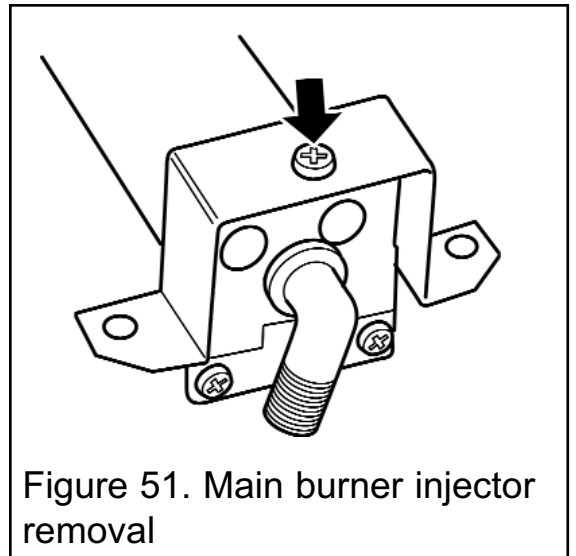

Figure 51. Main burner injector removal

OWNER GUIDE

FOR WARRANTY AND SERVICE INFORMATION
SEE PAGES 55 TO 59

OWNER GUIDE

LIST OF CONTENTS

<u>Section</u>	<u>Page</u>
SAFETY	46
APPLIANCE DIMENSIONS	47
GAS CONSUMPTION	49
OPERATING YOUR FIRE	50
The Oxysafe flame sensing and flue blockage safety system.	50
To gain access to the control knob.	50
To light the fire.	51
Glass bowing.	52
Lighting with a taper (For models that do not have glass panels).	52
To turn off.	52
CLEANING YOUR FIRE	53
Glass parts.	53
Metal Parts.	53
Ceramic fuel effect.	53
Burner.	54
FUEL BED REFITTING	54
MAINTENANCE	55
WARANTY AND SERVICE	55

This gas fire is designed to meet the most stringent quality, performance and safety requirements to provide you with many years' trouble-free service.

This guide aims to improve your understanding and appreciation of your gas fire by providing simple and informative instructions to ensure that you benefit from the excellent performance and features it has to offer.

OWNER GUIDE

SAFETY

IF YOU SMELL GAS

- **DON'T SMOKE.**
- **EXTINGUISH ALL NAKED FLAMES.**
- **DON'T TURN ELECTRICAL SWITCHES ON OR OFF.**
- **TURN OFF THE GAS SUPPLY AT THE METER OR TANK AS APPROPRIATE.**
- **OPEN DOORS AND WINDOWS TO GET RID OF THE GAS.**
- **IMMEDIATELY CALL THE GAS EMERGENCY SERVICE FROM A NEIGHBOURS PHONE - SEE YOUR LOCAL TELEPHONE DIRECTORY.**

Do have the fire installed by a competent person. In the United Kingdom, installation must be in accordance with the latest edition of the Gas Safety (installation & use) Regulations. In the Republic of Ireland, installation must be in accordance with all national and local regulations in force.

Do have the chimney swept prior to installation if it was previously used for solid fuel.

Do have the fire installed in accordance with the installation instructions.

Do provide a minimum clearance of 700mm from the base of the fireplace opening to any shelf made of wood or other combustible material where the shelf is not more than 150mm deep. For a shelf deeper than 150mm, add 12.5mm to the clearance for every 25mm of additional shelf depth (See graph1).

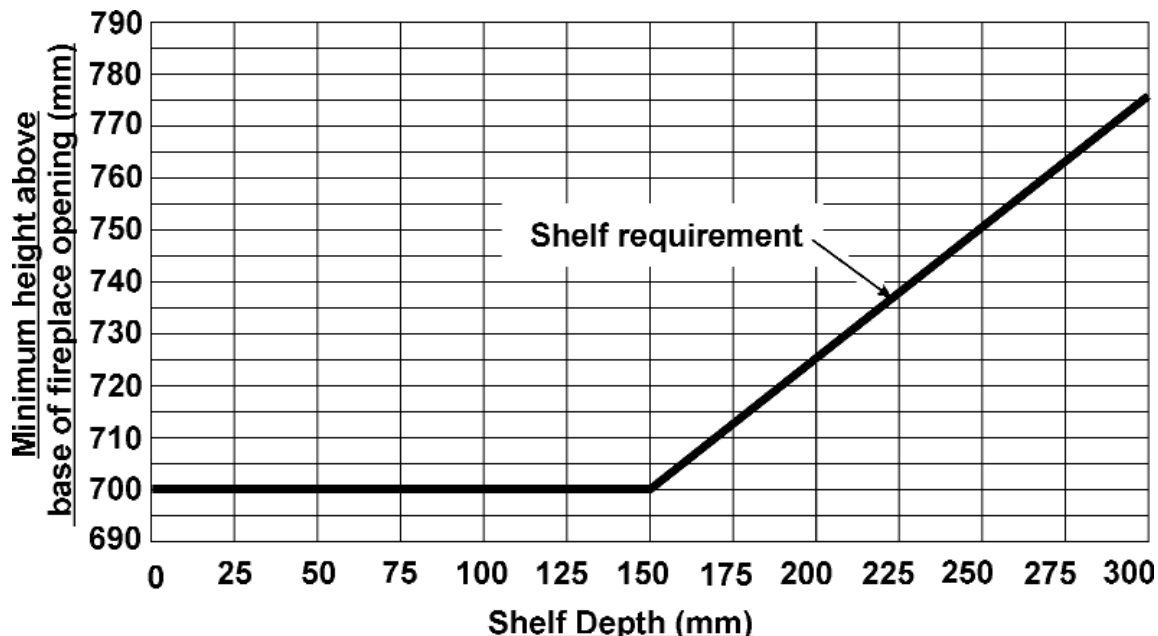

Graph 1. Combustible shelf clearances

Do wait three minutes before attempting to relight if the fire is switched off or the flames are extinguished for any reason. (Your fire is fitted with a safety device that will automatically shut off the gas supply to the fire if, for any reason, the flames go out).

Do get advice about the suitability of any wall covering near your fire. Soft wall coverings (e.g. embossed vinyl, etc.) which have a raised pattern are easily affected

OWNER GUIDE

by heat. They may, therefore, scorch or become discoloured when close to a heating appliance. Please bear this in mind whenever you are considering redecorating.

Do provide a minimum side clearance as detailed in figure 1. Please bear this in mind if ever you are considering altering the room.

Do provide a suitable guard that complies with BS 8423 for the protection of young children, the elderly, the infirm and pet animals. (The glass panel on the 'Fascination', 'Aspect Glass' and 'Tranquility' models conform to the requirements of B.S. 1945:1971 and satisfies the Heating Appliances (Fireguard) (Safety) Regulations 1991. The glass panel is very hot when the appliance is in use and should not be touched. It does not give full protection for young children, the elderly, the infirm or pet animals. The appliance should not be used if the glass is broken).

Don't hang clothing, towels or any other fabrics over the fire.

Don't add any extra ceramic fuel effect pieces above the number stated in the fuel effect installer and owner guide supplied with the ceramic fuel effect. This could cause incomplete combustion and safety hazard.

Don't put paper or any other material on the fire.

Don't place any combustible material (rugs, carpet, plastic tiles, etc.) on the hearth.

Don't attempt to clean or service the fire until it has been switched off and allowed to cool completely.

APPLIANCE DIMENSIONS

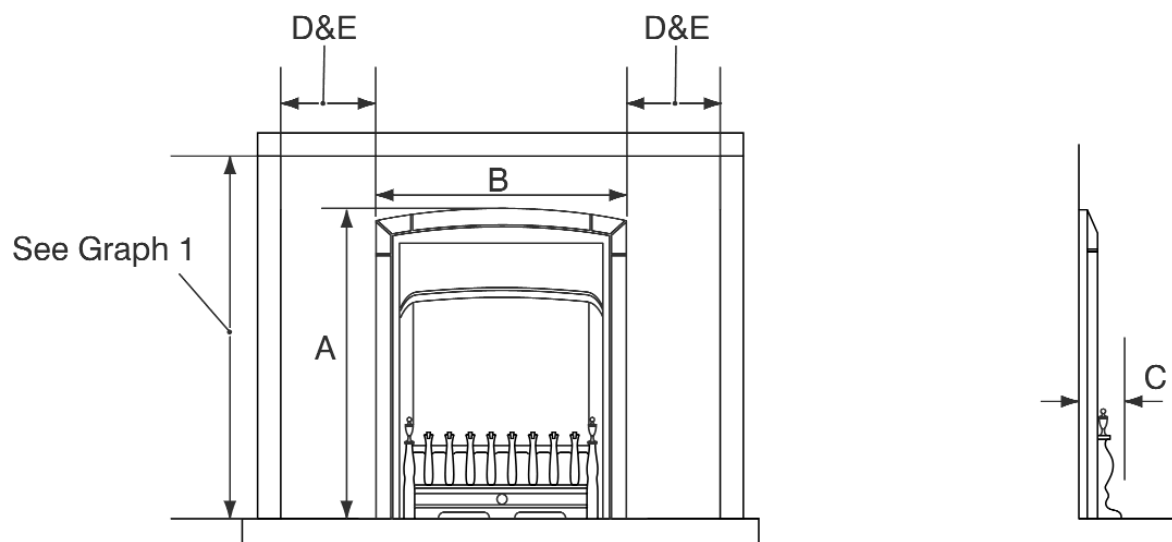

Figure 1. Appliance dimensions and clearances - SEE TABLE ON NEXT PAGE (Fascia may differ from that shown)

OWNER GUIDE

Key	Description	Model							
		Amour	Aspect	Eclipse	Fascination	Landscape & Serenity	Visia	Tranquility & Aspect Glass	
A	Appliance height (mm)	610	612	599	599	607	640	612	
B	Appliance width (mm)	560	505	520	520	976	930	505	
C	Appliance depth into room (mm)	30	13	25	61	72	40	50	
D	Minimum mandatory clearance to combustible surfaces projecting beyond the front of appliance (mm).	10	10	10	10	10	10	10	
E	Recommended clearance to non-combustible surfaces for access purposes (mm).	10	10	10	10	10	10	10	

Figure 1 continued. Appliance dimensions and clearances continued

OWNER GUIDE

GAS CONSUMPTION

Model 754 when fitted with Amour, Aspect, Eclipse, Landscape, Serenity and Visia fascia.

Has a maximum natural gas input of 5.1kW (Gross)

Has a maximum natural gas output of 2.6kW

Has a minimum natural gas input of 3.0kW (Gross)

Has a minimum natural gas output of 1.5kW

Model 754 when fitted with Aspect Glass and Tranquility fascia.

Has a maximum natural gas input of 5.2kW (Gross)

Has a maximum natural gas output of 2.4kW

Has a minimum natural gas input of 3.1kW (Gross)

Has a minimum natural gas output of 1.4kW

Model 754 when fitted with Fascination fascia.

Has a maximum natural gas input of 5.5kW (Gross)

Has a maximum natural gas output of 2.4kW

Has a minimum natural gas input of 3.1kW (Gross)

Has a minimum natural gas output of 1.4kW

Model 754 when fitted with Fascination fascia and converted to LPG with kit 05754M1.

Has a maximum natural gas input of 5.0kW (Gross)

Has a maximum natural gas output of 2.3kW

Has a minimum natural gas input of 4.6kW (Gross)

Has a minimum natural gas output of 2.1kW

OWNER GUIDE

OPERATING YOUR FIRE

PLEASE NOTE

When operating your fire for the first time, some vapours may be given off which may cause a slight odour and could possibly set off any smoke alarms in the immediate vicinity. These vapours are quite normal with new appliances. They are totally harmless and will disappear after a few hours use.

The Oxysafe flame sensing and flue blockage safety system.

For your safety, this appliance is fitted with a flue blockage safety device which will shut down the appliance in the event of abnormal flue conditions. ***This device is NOT a substitute for an independently mounted Carbon Monoxide detector.***

The device will also automatically shut off the gas supply to the fire if the pilot flame goes out due to lack of oxygen or for any other reason.

If this device starts to repeatedly shut off the gas, get expert advice.

This device incorporates a probe which senses that the heat from the pilot flame is correct. If this probe is cool, the device will prevent any gas flow unless the control knob is held in at the ignition position.

If, for any reason, the flames go out when the fire is hot or if the fire is turned off when hot, always ***wait at least three minutes before attempting to relight.***

To gain access to the control knob.

Aspect, Aspect Glass and Tranquility models.

To gain access to the control knob lower the bottom front cover. To do this, support the top and bottom of the lower front cover (See figure 2).

Amour model.

To gain access to the control knob lower the bottom front cover. To do this, hold the knob on the bottom front cover and pull gently.

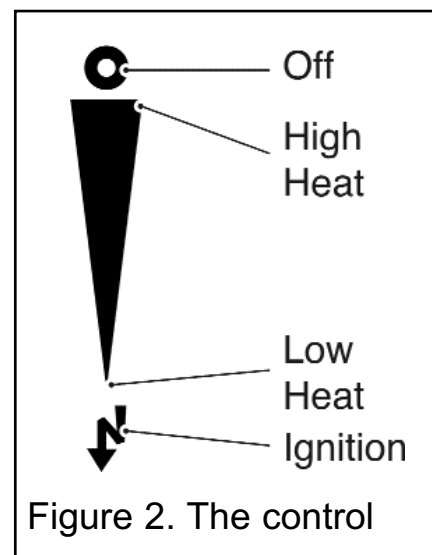

OWNER GUIDE

Eclipse and Fascination models.

To gain access to the control knob lower the bottom front cover. To do this, support the top edges of the lower front cover and pull gently (See figure 3).

Landscape, Serenity and Visia models.

To gain access to the control knob lower the bottom front cover. To do this, gently push the top of the front cover with the fingertips. The magnetic catch will release the front cover (See figure 4).

To light the fire.

- Depress the control knob and turn anticlockwise towards the PILOT/IGN position (See figure 5). A spark should be generated at the pilot while turning. The spark should ignite the pilot. The pilot flame can be seen at the left side of the fuel effect.

Keep the button at the PILOT/IGN position for a further ten seconds. This will prevent the flame sensing device from shutting off the gas while its probe warms up as explained previously.

- If the pilot does not ignite quickly repeat the procedure.

If after 10 seconds pilot ignition has not occurred, turn the control knob back to the “Off” position, wait for 3 minutes and then repeat the ignition procedure.

- When the pilot is alight and stable, partially depress the knob and turn to “LOW”. The pilot should then light the main burner at its low setting. There may be a delay of up to four seconds between the pilot lighting and ignition of the gas at the main burner. This is normal and is due to the time required to fill the main burner compartment with sufficient gas for ignition.

- When the main burner is alight at its low setting, partially depress the knob and gradually turn it anti-clockwise until the burner is at your desired level. The burner flames will gradually increase until

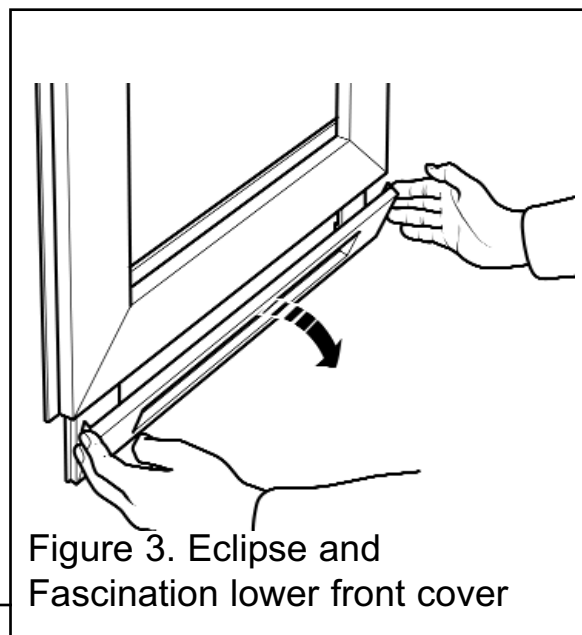

Figure 3. Eclipse and Fascination lower front cover

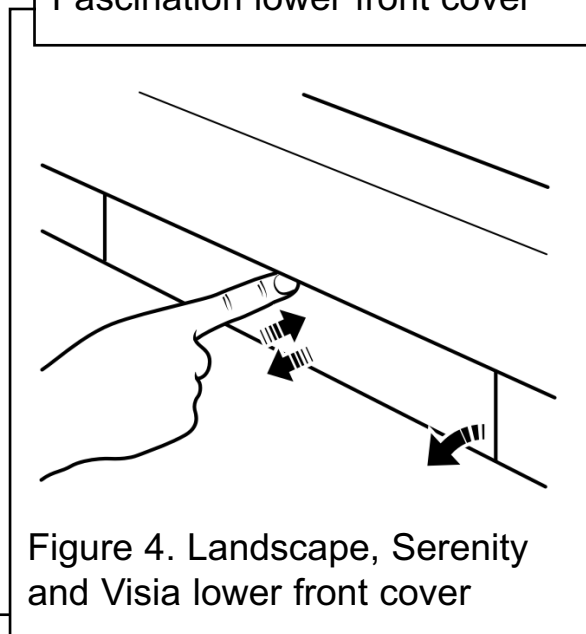

Figure 4. Landscape, Serenity and Visia lower front cover

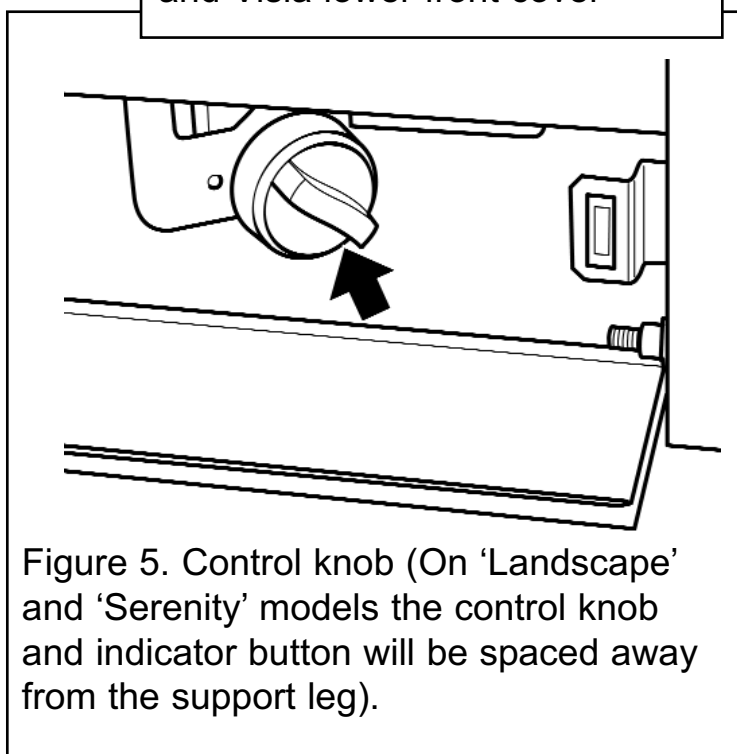

Figure 5. Control knob (On 'Landscape' and 'Serenity' models the control knob and indicator button will be spaced away from the support leg).

OWNER GUIDE

the knob reaches the “HIGH” position.

Note:

- i) If the flames go out while setting the control, repeat the full lighting procedure. If the flames repeatedly go out have the fire serviced.
- ii) Please note. When first turned on the flames will appear predominantly blue. The fuel effect will take time to warm up. Although some glow will be seen after approximately ten minutes, the full visual effect will only be apparent after a somewhat longer time.
- iii) The appliance will operate to its maximum potential if the flue is primed during the first 20 – 30 minutes of operation. To do this, simply set the control knob to its ‘HIGH’ setting. This will also burn off any carbon deposits that may have formed during previous operations.
- iv) If operating the appliance for long periods it is beneficial occasionally to change the settings. This will also help to remove any carbon deposits that may form during operation.

Glass bowing.

It is normal for the glass panel on the fascia to bow slightly when hot.

Lighting with a taper (For models that do not have glass panels).

(See figure 6).

In the unlikely event of failure of the ignition spark, the pilot can be lit by a taper or long spill. Insert the taper or spill into the gap in the fuel effect at the left hand side. Depress the control knob, turn it to PILOT/IGN.

To turn off.

- To turn the main burner off but leave the pilot alight, partially depress the knob and turn to PILOT/IGN.
- To turn the fire fully off, partially depress the knob and turn to OFF.
- **Wait at least three minutes before relighting.**
- **While cooling, the fuel effect may make some crackling noises. This is quite normal.**

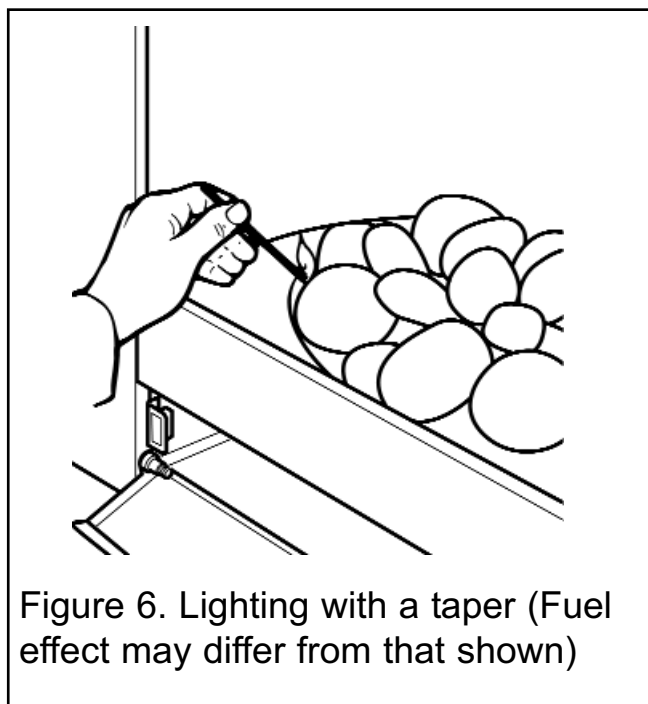

Figure 6. Lighting with a taper (Fuel effect may differ from that shown)

OWNER GUIDE

CLEANING YOUR FIRE

To maintain the high performance and quality finish of your fire please follow these guidelines:

- Before attempting to clean the fire, please remember to turn off the fire and wait for the appliance to cool completely. The fire will retain heat for some time before cleaning can begin.
- If any pieces of debris are found in the hotbox, have the chimney inspected before further use.

Metal Parts.

- Clean the metal parts with a slightly damp, lint free non-abrasive cloth and then dry.
- Do **not** use abrasive cleaners, as these will scratch the fire surface.
- **Fascia** - Clean the metal parts with a slightly damp cloth and then dry. If this does not work apply a very small amount of 'baby oil' to a lint free, non-abrasive cloth and wipe over the surface. Use a clean non-abrasive cloth to wipe off the oil.

Glass parts.

- Marks and stains on the glass can be removed using non-abrasive glass cleaner. Non-abrasive ceramic hob cleaner can be used to remove stains.
- Note: The decorative metal surfaces within the firebox are exposed to high temperatures. Great care has been taken to ensure that discolouration is kept to a minimum. However, the combination of heat and variable flue conditions may result in small amounts of discolouration or staining.

Ceramic fuel effect.

● On 'Aspect Glass', 'Fascination' and 'Tranquility' models the fascia will have to be removed to gain access to the ceramic fuel effect. The fascia is held in place by four retaining plates at the back of the fascia. These slot into four retaining brackets on the hotbox. To remove the fascia, hold the sides of the fascia and lift upward and forward. The fascia should lift clear of the hotbox (See figure 7). The fascia can be replaced in the reverse order.

- **This product uses fuel effect pieces containing Refractory Ceramic Fibres (RCF), which are man-made vitreous silicate fibres. Excessive exposure to this material may cause irritation to eyes, skin and respiratory tract. Consequently, it is important to take care when handling these articles to ensure that the release of dust is kept to a minimum.**

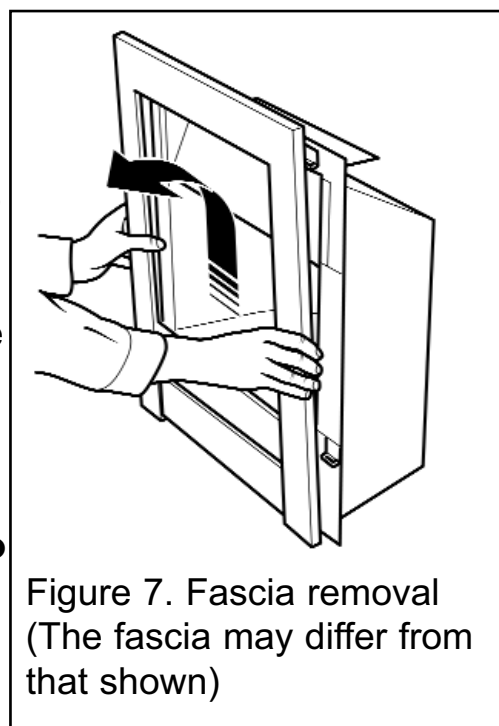

Figure 7. Fascia removal
(The fascia may differ from that shown)

OWNER GUIDE

- In the unlikely event of soot forming, light coatings will usually be burnt off during the normal operation of the fire.
- Should any soot accumulation become excessive, the fuel effect pieces should be removed from the fire for cleaning.
- Cleaning should be carried out in a well ventilated area or in the open air by gently brushing with the pieces held away from your face so that you avoid inhaling the dust.
- We do not recommend the use of a normal domestic vacuum cleaner which may blow dust back into the air.
- We suggest that you remove the ceramic fuel effect in the reverse order to that shown in the ceramic fuel effect installer and owner guide. This should have been left inside or attached to this guide by the installer.

Burner.

Remove any deposits of soot or other foreign matter from the solid areas of the burner with a dry soft brush. Be careful not to brush any particles into the open holes. Remove any particles from the holes with a vacuum cleaner fitted with a soft brush attachment. **Do not poke wire, etc. into the holes in the burner.**

FUEL BED REFITTING

- On 'Aspect Glass', 'Fascination' and 'Tranquility' models the fascia will have to be removed to gain access to the ceramic fuel effect. The fascia is held in place by four retaining plates at the back of the fascia. These slot into four retaining brackets on the hotbox. To remove the fascia, hold the sides of the fascia and lift upward and forward. The fascia should lift clear of the hotbox (See figure 7). The fascia can be replaced in the reverse order.

The installer and owner guide for the ceramic fuel effect is separate from this guide. The installer may have attached it to this guide or placed it inside. It is important that the installer and owner guide for the ceramic fuel effect is followed correctly. If replacing the ceramic fuel effect, where a new guide is supplied, follow the installer and owner guide supplied with the replacement fuel effect. Keep the replacement installer and owner guide with this owner guide for future reference.

OWNER GUIDE

MAINTENANCE

Regular maintenance.

In order to achieve and maintain high levels of personal safety and performance efficiency, it is essential that the opening at the back of the fire and the flue are kept clear of any form of obstruction. It is possible that deposits of mortar or soot could fall and accumulate causing the flue to be blocked or restricted and so preventing proper clearance of dangerous exhaust fumes.

In the United Kingdom it is the law that a landlord must have any gas appliance, flue and pipework which is situated in a tenant's premises checked for safety at least every twelve months by a competent person (In the U.K, a CORGI registered installer).

We recommend that all gas appliances and their flues, wherever situated, are checked annually.

WARRANTY AND SERVICE

Standard Warranty Terms & Conditions

The warranty is for 12 months subject to contract.

In the United Kingdom servicing can be carried out either by a **heateam** service engineer or a **CORGI** registered installer.

You must register your fire with **heateam**, the service division of Baxi Heating UK Limited, either by completing and returning the registration card or calling our free telephone registration line on **0800 032 72 44**.

It is also a requirement of the warranty that the fire has an annual service (every 12 months) in accordance with the installation and servicing instructions, performed by a CORGI registered engineer. If you would like **heateam** to carry this out this service, please call on **08700 60 30 60**.

Our promise to you

If you experience a fault with your new fire, we aim to provide a safe and high quality repair service supported by our dedicated national network of highly skilled engineers. If your installer can't resolve the problem for you, we will do everything we can to get an engineer out to you as quickly as possible. Nothing in this warranty will affect your statutory rights.

OWNER GUIDE

What you need to do if you experience a problem with the operation of the fire:

- You should always contact your installer first, because the cause of the fault may not be related to the fire.
- If your installer confirms that the fault is with the fire and they can't repair it, our friendly customer service team is on hand to help.
- Simply call our service division heateam on 08706 090 081 to book an engineer visit or for any general advice that you may need. Our contact centre is open Monday to Friday 8am – 6pm, weekends and Bank Holidays 8.30am – 2pm, excluding Christmas Day and New Years day.

When calling **heateam**, it would be helpful if you could have the following information to hand:-

1. Fire serial number and fascia code (Located on the information label - See figure 8 on page 59).
2. Date of installation.
3. Your installer name and address details.
4. Fire make and model number.
5. Proof of purchase (if you do not have the fire serial number).

Note: details 1 – 4 should be recorded on pages 58 & 59 at the end of this guide.

What this warranty covers

Free of charge repair or replacement of components found to be of faulty manufacture.

Free of charge replacement of the complete unit providing the failure is related to a manufacturing fault that cannot be repaired or is uneconomic to repair.

What this warranty does not cover

Repairs to fires which haven't been installed and commissioned properly and as set out in the installation instructions.

Faults caused by inadequate supply of gas or electricity (where applicable).

Reimbursement of any third party repair or replacement costs that we haven't been told about or agreed with you in advance.

Compensation or consequential losses (e.g. loss of earnings, business losses, stress and inconvenience) arising from a production breakdown, including repair delays caused by factors outside our reasonable control.

OWNER GUIDE

OWNER GUIDE

Installer Details (Block Capitals)

Installer Name	
Corgi Registration Number.	
Company Name.	
Company Address	
Company Telephone number	
Company Fax number	

OWNER GUIDE

Model

Serial number (Can be found on the information label - See figure 8)

A LABEL CONTAINING THE SERIAL NUMBER MAY HAVE BEEN PLACED INSIDE THIS BOX.

Fascia name (Block Capitals)

Fascia code - Can be found close to the information label (Block Capitals)

A LABEL CONTAINING THE FASCIA CODE MAY HAVE BEEN PLACED INSIDE THIS BOX.

Brand (Please tick)

Baxi

Valor

Wonderfire

Other.....

Date of Installation

D D M M Y Y

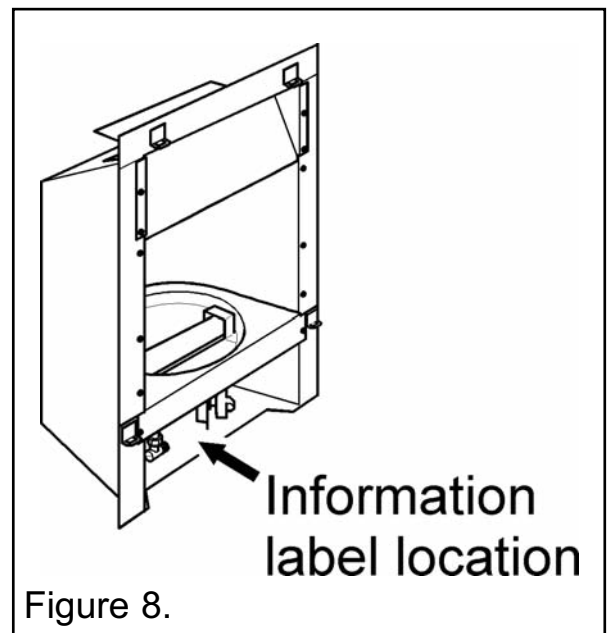

VALOR FIRES