

**Wonderfire**

**I N S T A L L E R G U I D E**

**For**

**MODEL 5403**

**LINCOLN**

**Room sealed  
Radiant / Convector  
Gas Fire**

**(G.C. 32-032-20)**

*Please keep in a safe place for future reference*

**Please leave this Installer Guide with the user**

This appliance is for use with natural gas (G20)  
This appliance is for use in the United Kingdom  
(GB) and the Republic of Ireland (IE) only.

**C U S T O M E R C A R E**

This Installer Guide gives sufficient details to enable the appliance to be installed and maintained. If further information is required, our **Wonderfire Service Department** will be pleased to help.

**Please telephone 0121 386 6203**  
**In the Republic of Ireland call 353183 75114**

# C O N T E N T S

<b>1</b>	<b>APPLIANCE DATA.....</b>	<b>4</b>
<b>2</b>	<b>GENERAL INSTALLATION REQUIREMENTS.....</b>	<b>6</b>
<b>3</b>	<b>PRELIMINARY CHECKS .....</b>	<b>8</b>
3.1	Unpacking .....	8
3.2	Window & Fuel Bed Removal .....	8
3.3	Preliminary Checks .....	8
<b>4</b>	<b>GAS SUPPLY INSTALLATION .....</b>	<b>9</b>
<b>5</b>	<b>WALL PREPARATION.....</b>	<b>9</b>
5.1	Select Appliance Position.....	9
5.2	Constructing a Recessed Opening.....	9
5.3	Combustible Wall Materials.....	10
5.4	Cut the Flue Hole – Brick, Stone etc. Building.....	10
5.5	Cut the Flue Hole –Timber Frame Buildings .....	11
5.6	Prepare appliance Fixing holes .....	11
<b>6</b>	<b>FLUE TERMINAL INSTALLATION.....</b>	<b>12</b>
6.1	Cutting Flue to size .....	12
6.2	Fitting to Wall.....	13
6.3	Fitting Terminal Guard .....	13
<b>7</b>	<b>GAS CONNECTION, FUEL BED &amp; WINDOW FITTING.....</b>	<b>14</b>
7.1	Connect the Gas Supply Pipe.....	14
7.2	Fit the Ceramic Fuel Bed .....	14
7.3	Refit the Window.....	14
<b>8</b>	<b>FULL OPERATIONAL CHECKS .....</b>	<b>15</b>
8.1	Check for Leaks.....	15
8.2	Check Control Operation .....	15
8.3	Check Reference Pressure .....	15
<b>9</b>	<b>FITTING FRONT UNIT .....</b>	<b>16</b>
<b>10</b>	<b>FINAL REVIEW.....</b>	<b>17</b>
<b>11</b>	<b>SERVICING &amp; PARTS REPLACEMENT .....</b>	<b>18</b>
11.1	To Remove Front Unit.....	18
11.2	To Remove Window Unit .....	18
11.3	To Remove The Ceramic Fuel Bed & Rear Wall .....	18
11.4	To Remove & Replace the Ceramic Burner plaques .....	19
11.5	To Remove Burner Can and Plaque Unit .....	19
11.6	To Remove the Complete Burner Module.....	19
11.7	To Remove the Injector.....	20
11.8	To Remove the Pilot Unit.....	20
11.9	To Remove The Gas Valve.....	20
11.10	To Remove Switch & Wiring Loom.....	21
11.11	Short List of Spares .....	22

## 1 APPLIANCE DATA

This product uses a burner compartment rear wall and gaskets containing Refractory Ceramic Fibres (RCF), which are man-made vitreous silicate fibres. Excessive exposure to these materials may cause temporary irritation to eyes, skin and respiratory tract. Consequently, it makes sense to take care when handling these articles to ensure that the release of dust is kept to a minimum. To ensure that the release of fibres from these RCF articles is kept to a minimum, during installation and servicing we recommend that you use a HEPA filtered vacuum to remove any dust and soot accumulated in and around the fire before and after working on the fire. When replacing these articles we recommend that the replaced items are not broken up, but are sealed within a heavy duty polythene bag, clearly labelled as RCF waste. This is not classified as "hazardous waste" and may be disposed of at a tipping site licensed for the disposal of industrial waste. Protective clothing is not required when handling these articles, but we recommend you follow the normal hygiene rules of not smoking, eating or drinking in the work area and always wash your hands before eating or drinking.

This appliance does not contain any component manufactured from asbestos or asbestos related products.

The appliance data label is on a plate on a tie below the burner and visible when the bottom front cover is removed.

<b>Main Burner:</b>	Simplex aerated
<b>Gas Connection:</b>	8mm Pipe.
<b>Gross Gas Consumption:</b>	3.65kW at maximum position.
<b>Maximum output:</b>	2.7kW
<b>Burner Injector:</b>	Bray Cat. 960 Size 270.
<b>Pressure Setting (Cold):</b>	19.0 ± 0.75mbar
<b>Aeration Adjustment:</b>	None required.
<b>Controls:</b>	Manual pilot and main burner off/on control (Right control). Separate variable control (Left control) for main burner can be operated by its control knob or from the high level rocker switch. Fitted with flame supervision device and integral piezo igniter
<b>Pilot Unit:</b>	Left side of firebox. Combined Pilot jet thermocouple sensor and electrode. SIT Ref.. OP9706.
<b>Battery</b>	4 x 1.5V AA
<b>Walls:</b>	Minimum 102mm (4in.) thick Maximum 660mm (26in.) thick for standard appliance Maximum 965mm (38in.) thick with optional flue extension kit no. 595149

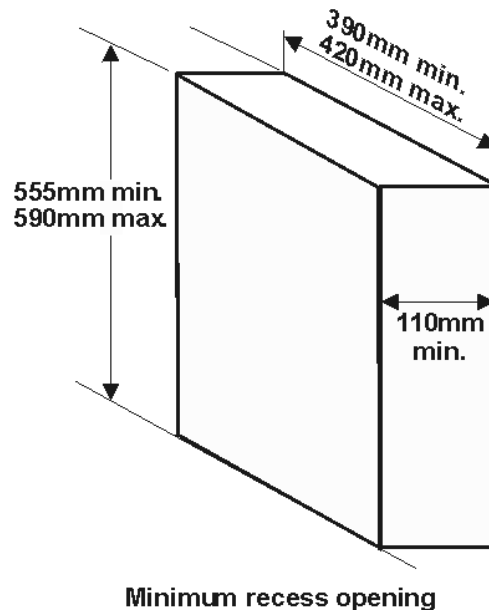
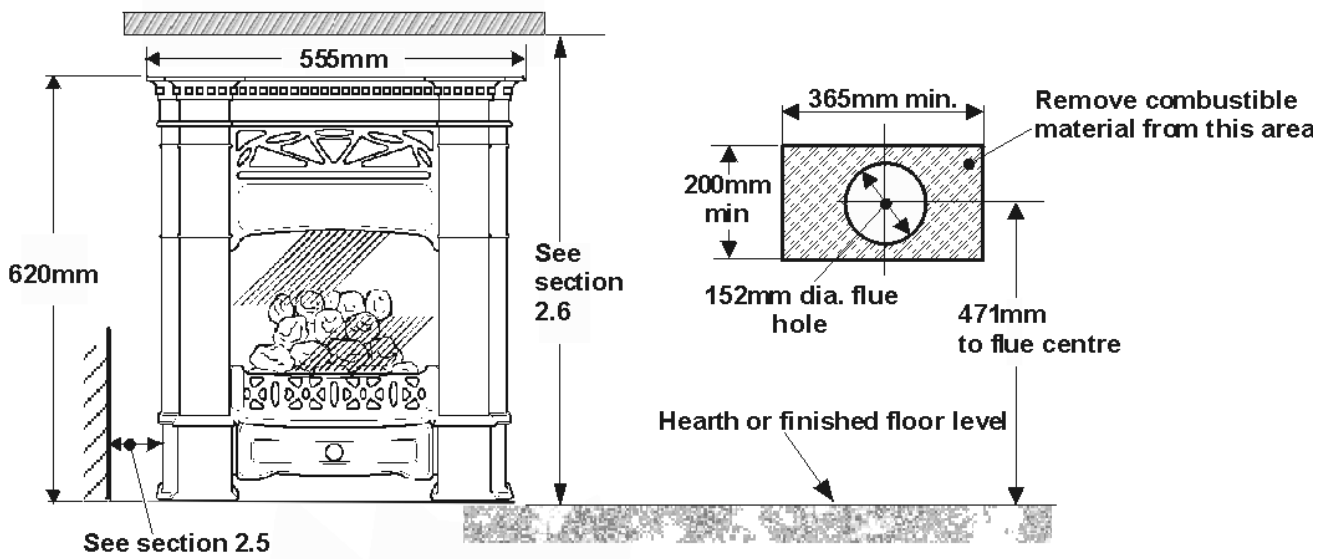

Figure 1

## 2 GENERAL INSTALLATION REQUIREMENTS

**2.1** The appliance can be installed into the following :-

- a) A minimum 4.5in rebate surround or Valor 5in. spacer kit Part No 595129. Where either of these are mounted to a combustible wall make sure that there is no combustible material or combustible cladding in the area indicated on the wall fixing template.
- b) A 2in rebate surround in conjunction with the Valor spacer kit Part No 595139. Where the surround is mounted to a combustible wall make sure that there is no combustible material or combustible cladding in the area indicated on the wall-fixing template.
- c) Recessed into a builder's opening or cavity of a non- combustible wall. The minimum cavity size is shown in figure 1. A lintel may be required above the recess opening. If in doubt seek expert building advice. Lintel construction details are given in section 5 of this guide. ***This appliance must not be recessed into a combustible wall***

**2.2** Note that soft wall coverings (e.g. embossed vinyl etc.) are easily affected by heat. They may therefore, scorch or become discoloured when close to a heating appliance. Please bear this in mind when installing.

**2.3** Installation to a timber-framed building should be in accordance with the relevant sections of The Institute of Gas Engineers publication IGE/UP/7 "Gas installations in timber frame buildings". Please note that advice should be sought before installing in a timber frame building since the alterations required may nullify any NHBC cover relating to the property. If in doubt, guidance should be requested from your local authority planning or building department. ***Under no circumstances is the fire to be recessed into Timber frame constructions. For timber framed installations see section 5.***

**2.4** The installation must be in accordance with these instructions.

For the user's protection, in the United Kingdom it is the law that all gas appliances are installed by competent persons in accordance with the current edition of the Gas Safety (Installation and Use) Regulations. Failure to install the appliance correctly could lead to prosecution. The Council for the Registration of Gas Installers (CORGI) requires its members to work to recognised standards.

In the United Kingdom the installation must also be in accordance with:

All the relevant parts of local regulations.

The current edition of the Building Regulations issued by the Department of the Environment and the Welsh Office or the Building Standards (Scotland) (Consolidation) Regulations issued by the Scottish Development Department.

All relevant codes of practice.

The relevant parts of the current editions of the following British Standards:-

BS 5440 Part 1

BS 5871 Part 1

BS 6891

In the republic of Ireland the installation must also conform to:

- a) The relevant parts of the current edition of IS 813
- b) All applicable national and local rules in force.

**2.5** A minimum clearance of 51mm should be maintained at each side of the fire for servicing access.

Any combustible side wall or other combustible projection must be at least 102mm clear from direct exposure to the radiant surface of the appliance unless suitably protected.

**2.6** The minimum height from the top surface of the hearth or finished floor to the underside of any shelf made from wood or other combustible materials is as follows:-

- For a shelf up to 150mm deep  
Minimum height = 780mm.
- For a shelf deeper than 150mm  
780mm + 12.5mm for every 25mm depth over 150mm.

There is no restriction on the position or depth of non-combustible projections for all normal installations but a space of at least 30mm should be allowed above the top of the appliance to enable removal of the front castings. Installation into an unusually tightly restricted recess, however, could cause the temperature of the appliance surfaces to become unacceptably high..

**2.7** It is advisable that combustible fabrics such as curtains are not fitted above the fire. If, however, this is unavoidable, the extreme bottom edge of the fabric must be at least 780mm above the top surface of the hearth or finished floor.

**2.8** This appliance does not require a non-combustible hearth. It can be installed on any hard surface. This surface should be level and sufficiently flat to enable the bottom of the front casing and castings to be aligned horizontally. Any unevenness (Uneven tiles, Cotswold stone etc.) should be rectified.

***The appliance must not stand on carpet or other textured surfaces which may interfere with the flow of convection air through the bottom of the appliance.*** The floor surface that must be free of carpets, rugs or other fabric coverings should be at least as wide as the appliance outer case and project forward at least 300mm from the rear wall. In order to prevent carpet etc. being placed within this area, we strongly recommend that the appliance is installed on a raised hearth or that the periphery of this area is bordered by a fender.

2.9 The appliance can be fitted to a purpose made proprietary class “O” 150° surround.

2.10 A hole 152mm (6in) dia. is required through the wall for the flue unit.  
The height of the hole centre is shown in figure 1 and on the wall-fixing template supplied with the appliance.

2.11 This appliance has exposed battery and electric motor components. It is not recommended, therefore, that it be used in a room containing a bath or shower or where steam is regularly present due to the possibility of corrosion or electrical shorting.

2.12 Minimum allowable distances from the terminal are shown in figure 2 and table 1:-

TABLE 1		
	Terminal Position	Minimum Distance (mm)
A	Directly below an openable window or other opening e.g. air brick	300
B	Below gutters, soil pipes or drain pipes	300
C	Below eaves	300
D	Below balconies or car port roof	600
E	From vertical drain pipes and soil pipes	75
F	From internal or external corners	600
G	Above ground, roof or balcony level	300
H	From a surface facing a terminal	600
I	From a terminal facing a terminal	600
J	From an opening in a car port (e.g. door, window) into dwelling	1200
K	Vertically from a terminal on the same wall	1500
L	Horizontally from a terminal on the same wall	300

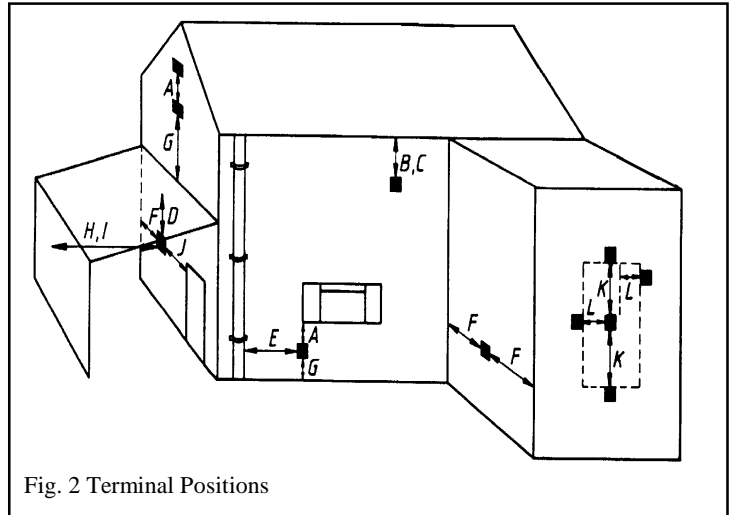

2.13 A terminal guard is supplied with this appliance.  
In England and Wales the Building Regulations require a terminal guard to be fitted if the terminal could come into contact with people near the building or be subject to damage. We recommend that the guard is fitted where contact with or damage to the terminal is possible even if regulations do not demand it.

2.14 A concealed gas supply connection can be made through the rear left panel. Visible front connection can be from the left or right side.

2.15 No special ventilation bricks or vents into the room containing the appliance are required.

## 3 PRELIMINARY CHECKS

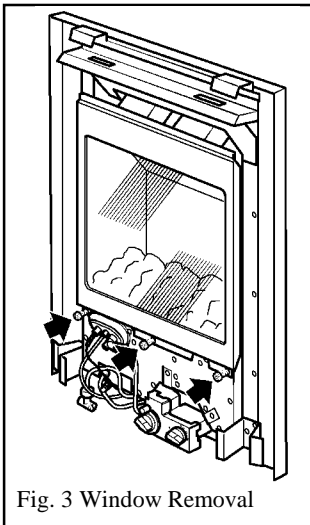

Fig. 3 Window Removal

### 3.1 Unpacking

This appliance is supplied in two cartons:-

#### Pack 1

- 1 Main fire assembly
- 1 Ceramic fuel bed (Packed inside the fire)
- 1 Nut & olive for 8mm inlet pipe
- 1 Flue unit
- 1 Wall fixing template
- 2 Fire retaining cables
- 2 Eyebolts
- 2 Fibre wall plugs
- 2 No 6 tapping screws
- 8 Woodscrews
- 8 Plastic wall plugs
- 1 Length of flue sealing tape
- 1 Literature pack

4 Batteries 1.5V AA

1 Fascia bottom infill apron (Black)

#### Pack 2

**This pack weighs around 20kg (44lbs). To avoid any risk of injury, if you have any doubt about your ability to safely lift this pack and its contents, ask someone to assist you.**

1 Fascia casting assembly including ash pan.

1 Bag containing various metal brackets, supports, shields and screws – **Discard these parts. They are not required for use with this model (Model 5403)**

Remove all the items carefully to prevent damage. Some items may be contained in the packaging fitments - Examine the packaging carefully before discarding. Check that all the items are present and undamaged.

3.0mm -4.0mm

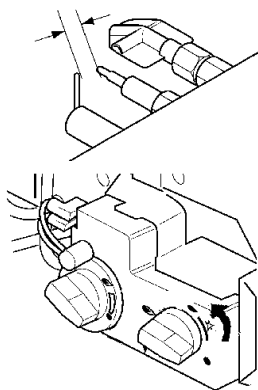

Figure 4 Ignition check

### 3.2 Window & Fuel Bed Removal

- Unscrew and remove the three spring loaded window fixing screws and washers from the base of the window frame. See figure 3. Keep the screws and washers in a safe place.
- Gently swing the base of the window frame forward while lifting the frame upwards. The window should lift clear of the fire. Put the window in a safe place away from your immediate work area.
- Carefully remove the ceramic coal fuel bed in its packaging. The ceramic coal is a single piece. Put the coal in a safe place away from your immediate work area.

### 3.3 Preliminary Checks

#### 3.3.1 Check Ignition Spark

See figure 4.

The pilot burner and electrode unit is at the left front corner of the burner.

Push in the right hand control knob and turn anticlockwise through the ignition

position marked and up to the pilot position marked .

A spark should flash across from the pilot electrode to the pilot burner hood. If there is no spark, check that the spark gap is as shown.

#### 3.3.2 Check Flame Control Motor

See figure 5

- Lift the plastic battery holder out of its metal support situated at the lower right corner.
- Fit the four 1.5V batteries and replace the battery holder.
- Depress the top half of the rocker switch located at the right side of the appliance

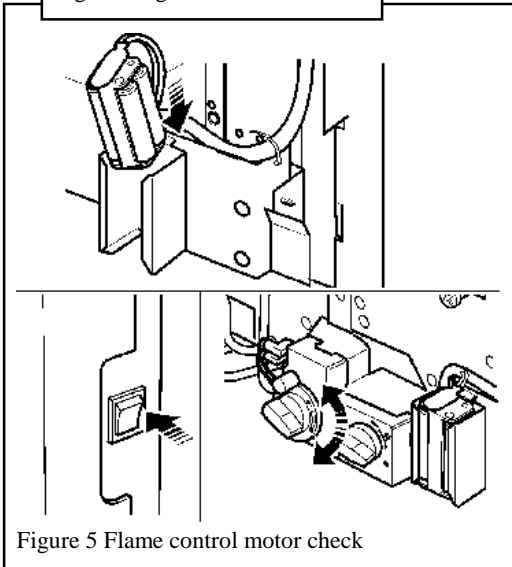

Figure 5 Flame control motor check

case. This should cause the flame control knob (The left-hand control knob) to rotate anticlockwise until it is vertical. Depressing the bottom half of the rocker switch should then cause the knob to rotate almost 180° clockwise. A clicking sound will be heard while the flame control knob is rotating.



## 4 GAS SUPPLY INSTALLATION

A nut & olive are provided for an 8mm pipe inlet connection to the elbow at the bottom front of the appliance. The elbow can be rotated to allow a connection from any direction. The elbow includes a valve for isolating the gas supply. The supply pipe must be rigid material. Flexible pipe must not be used.

### Concealed Supply pipe connecting from rear of the appliance

Before the appliance is installed it will be necessary to extend the supply line so that it will project through the sealed opening at the back of the fire case and run to the elbow at the front.

Make sure that the supply line run up to the rear opening is kept away from the area that will be taken by the appliance case when it is installed. Note that the centre of the appliance inlet elbow is 25mm above the floor.

The inlet elbow should be removed from the appliance and fitted to the supply pipe at this stage.

Cut a slit in the seal at the back of the appliance case. The seal must envelop the pipe. **Do not slit the seal unless the supply pipe is to pass through it.**

*Cap the open end of any supply pipe installed before the wall is drilled to prevent any debris or dust etc. entering the pipe.*

## 5 WALL PREPARATION

### 5.1 Select Appliance Position

The flue must be installed so that it is at right angles to the back panel of the fire all round the flue circumference.

For timber framed buildings make sure that the flue opening will be between studs. When being recessed into a non-combustible wall or builders opening the fire itself should be fitted vertically against a flat wall. Where this is difficult to achieve due to building inaccuracies care should be taken to ensure that the back of the fire is not stressed in any way due to distortion of the appliance when tightening the fixing screws. Where necessary, non-combustible packing pieces should be used to provide a satisfactory fixing surface.

### 5.2 Constructing a Recessed Opening

***Under no circumstances is the fire to be recessed into Timber frame constructions or any other combustible wall.***

The recess in the wall for the appliance should be to the size shown in figure 1. The bottom of the recess should be at the same level as the finished floor in front of the appliance.

A lintel may be required above the recess for the convection box. If in doubt, seek expert building advice before commencing to cut the recess.

#### 5.2.1 Fitting a lintel

Whenever a lintel is required to support the recess in the inner leaf of a brick/blockwork building, follow the method outlined below. See figures 6 & 7. The lintel should be either steel (Catnic) or reinforced precast concrete. It should be 750mm long x 75mm deep x inner leaf thickness.

- The opening should be, as near as possible, centrally below a joint in the inner leaf block.
- Cut out the opening for the lintel.
- Where cutting through masonry, drill pilot holes and then cut out the slot using a mechanical cutter. This will minimise damage to the surrounding structure.
- Insert the lintel. Bed the lintel on mortar. Don't dry bed. Slate pin to ensure the lintel and structure above is secure and safe
- Make the opening below the lintel by removing the masonry and clearing debris. If the cavity has loose fill (e.g. granular) insulation material, pack the edges of the opening with Rockwool as you proceed to hold back the insulating material.

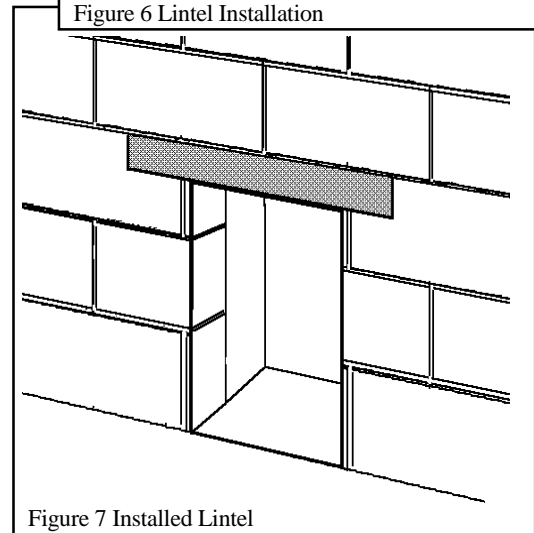
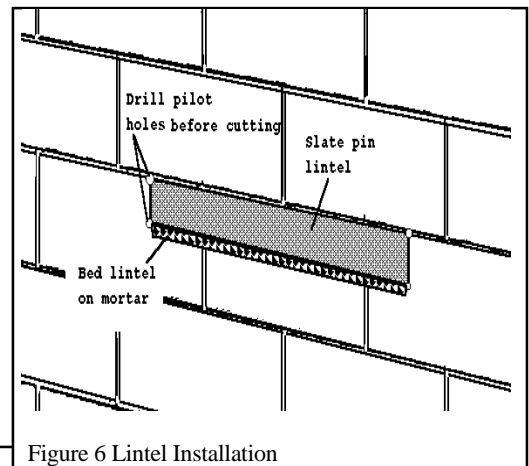

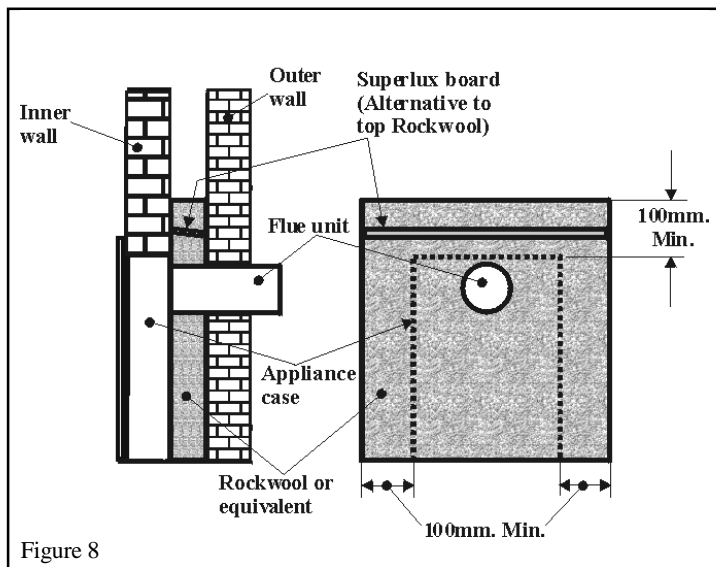

Figure 8

usual 12.5mm thick plasterboard plus a 12.5mm thick sheet of non-combustible insulating material (e.g. fibre cement board). As an option, a pre-cut insulating sheet is available from your appliance supplier or direct from Wonderfire – Ask for Wonderfire part no. 591229. The insulating sheet can be used to seal the annular gap between the flue unit and the inner leaf sleeve – see section 5.5. Do not permanently fix the insulating sheet to the wall at this stage – see section 6.2.

## 5.4 Cut the Flue Hole – Brick, Stone etc. Building

Cut the hole for the flue unit. Make sure that it is straight and level. Though a hammer and chisel can be used, using a core drill is by far the quickest and simplest method for normal brickwork.

- Before cutting the hole in the wall make sure that the height to the top surface of the finished floor or hearth is known. The height from this surface to the flue hole centre is shown in figure 1. The terminal position must also comply with the location requirements given in section 2.12.
- Place dust sheets on the floor and over any furnishings etc.
- Place the template against the wall. Make sure that the centre of the flue hole is as shown in figure 1.
- Pierce the template at the centre of the screw fixing holes and the flue hole and mark the positions on the wall. Remove the template.

### 5.4.1 Core Drilling

- Drill a pilot hole through the wall. Inspect the hole to ensure that it is in the brickwork and not in mortar. If it is in mortar, it is advisable to reposition the hole approximately 25mm away - Make sure that the minimum side clearances and height are complied with. Remember to reposition the screw fixing holes.
- Drill the flue hole with a 152mm (6in) core drill. Where practical, it is recommended that the hole is drilled from inside the building to about half the wall depth with the remainder drilled from outside. This ensures that the edges of the hole are clean on both sides.

### 5.4.2 Hammer & Chisel Cutting

- Mark a 152mm (6in) diameter circle for the flue hole. Chisel out the area marked.
- It may be necessary to make good both the internal and external wall faces. To achieve a neat finish and to make any future removal of the flue unit easier, it is recommended that a cardboard cylinder is formed around the flue unit and inserted in the hole while making good. Remove the cardboard cylinder after making good.

### 5.4.3 Leaving a Hole - Building under Construction

- It will be convenient to use a non-corrosive metal tube 160mm diameter built into the wall at the correct position for the flue unit.

## 5.2.2 Preparing a Wall Cavity

- The wall cavity must not be bridged other than by the flue unit. The appliance case must not project into the cavity between the inner and outer walls by more than 10mm.
- The cavity should be sealed where the opening has been cut. We recommend filling fully across the cavity with Rockwool or equivalent to at least 100mm above and each side of the recess opening. See figure 8.
- An alternative to rockwool **above** the opening is to seal across the top of the cavity with superlux board or equivalent. The board should slope downwards to the back so that any moisture will be channelled to the outside. See figure 8.

## 5.3 Combustible Wall Materials

- For brick or other non-combustible wall constructions, be sure to remove any combustible wall cladding material from the area shown in figure 1.
- For Timber frame buildings, the back surface of the appliance case must be separated from the timber frame by 25mm of non-combustible material. This can consist of the

## 5.5 Cut the Flue Hole – Timber Frame Buildings

- Drill the pilot hole and hole in outer wall as section 5.4.
- Since the flue will pass through combustible material in the inner leaf of the wall, a non-combustible sleeve 203mm (8in.) diameter will be required round the flue. See figure 9.
- Cut a hole through the inner leaf to accommodate a non-combustible sleeve 203mm (8in.) outside diameter. To minimise the effect of breaking through the vapour control layer (VCL), if possible, cut the hole approximately 10mm undersize in so that the sleeve will be forced through the layer. A recommended technique for cutting the inner leaf is shown in figure 9.
- Fit the non-combustible sleeve to the inner leaf. The sleeve must extend to be at least flush with the breather membrane/timber sheathing but must not protrude more than 10mm into the cavity.

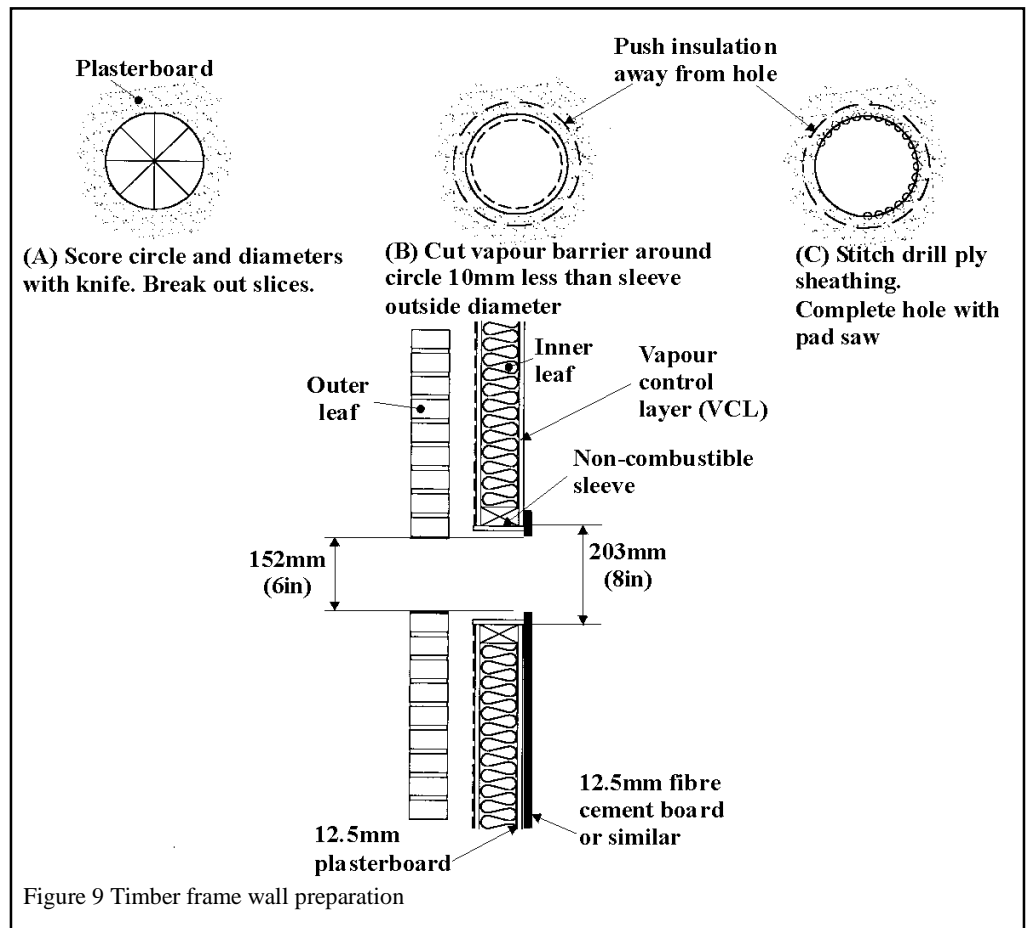

- The annular gap between the flue unit and the sleeve must be sealed to prevent air heat and moisture passing along it. The 12.5mm insulating sheet (See section 5.3) can be used for this. Do not permanently fix the insulating sheet to the wall at this stage – see section 6.2

## 5.6 Prepare appliance Fixing holes

### 5.6.1 Screwing case to wall

- Recheck the position of the screw fixing holes relative to the flue hole.
- Drill the four fixing holes to a minimum depth of 42mm using a 7mm diameter masonry drill.
- Insert four plastic wall plugs supplied.

### 5.6.2 Using cable retention

- Thread the two tension cables through the appliance case side holes as shown in figure 9a.
- Move the appliance towards the recess and mark on the recess back wall the position for the two eyebolt holes.
- Remove the appliance and drill at the marked positions using a no.12 masonry drill.
- Insert the two fibre wall plugs supplied.
- Fit the two eyebolts.

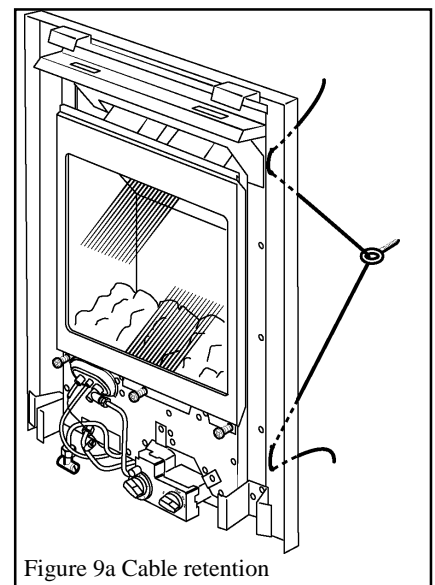

## 6 FLUE TERMINAL INSTALLATION

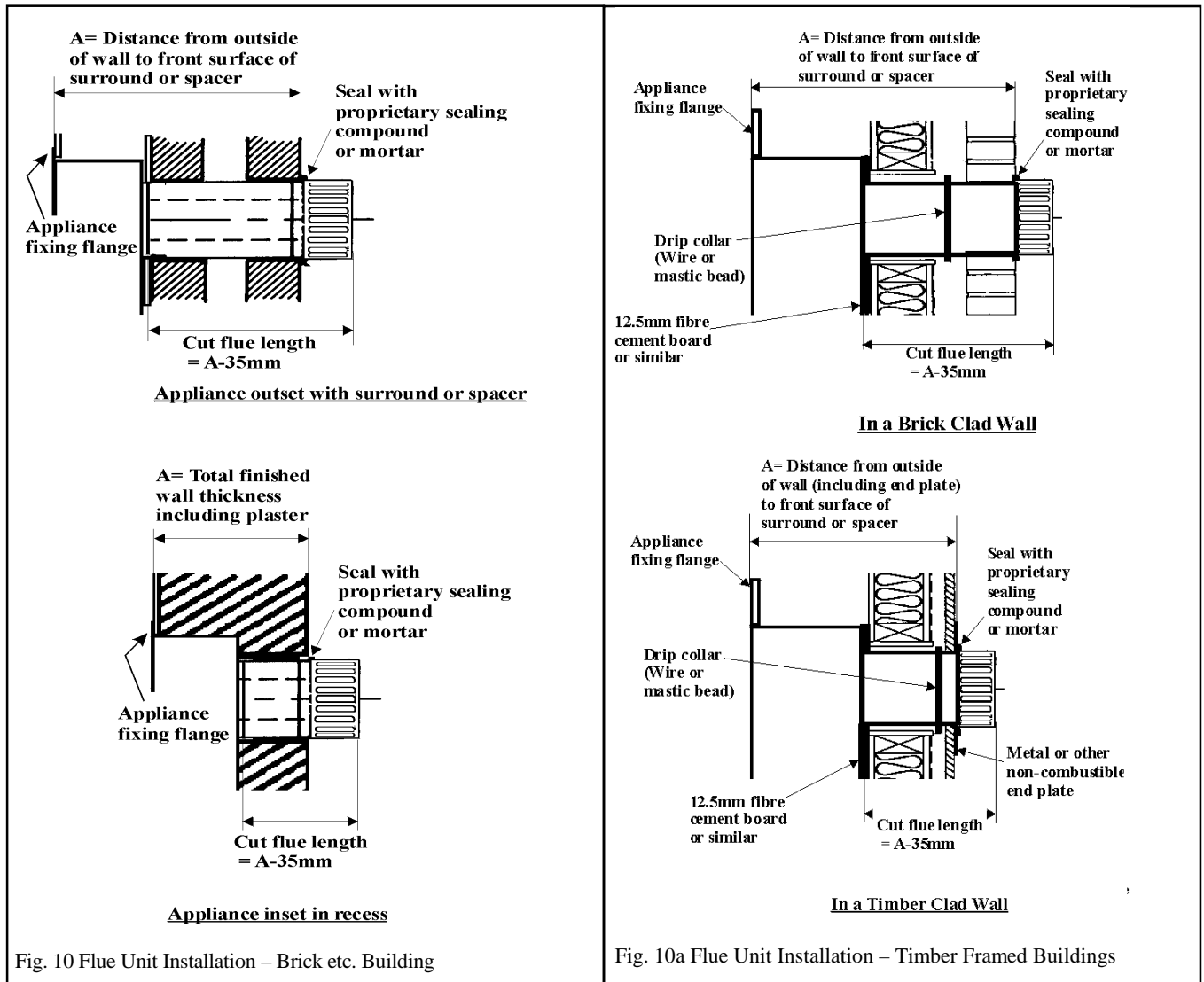

### 6.1 Cutting Flue to size

- For outset appliances with surround or spacer**

Measure the total wall thickness from the outside surface of the wall to the inside face of the surround or spacer. Deduct 35mm from this measurement to obtain the correct length of flue unit required. See figures 10 & 10a .

**For appliances inset in a recess**

Measure the total finished wall thickness including plaster etc. Deduct 35mm from this measurement to obtain the correct length of flue unit required.

See figure 10.
- Mark off the flue length on the outer (air) tube measuring from the end of the terminal.
- Insert the polystyrene ring between the inner and outer tubes to support them. Cut both tubes squarely at the marked distance. **Important: Remove all polystyrene from the flue unit after cutting.**

## 6.2 Fitting to Wall

- Fit the flue tubes firmly over the spigots at the rear of the fire. Make sure that the seam on the flue tube is not at the bottom. Push on until the outer (air) tube just covers the slots in the appliance outer spigot. See figure 11
- Secure the flue to the fire by drilling through the outer flue tube and outer spigot at a distance of between 6mm & 7mm from the cut end of the outer flue tube and securing with the two no.6 self tapping screws supplied. See figure 11.
- Seal the flue unit all round the circumference of the outer spigot with the tape supplied.
- **Timber frame buildings:** Offer the fire complete with flue unit through the insulating sheet (mentioned in section 5.3). Fit a drip collar round the flue positioned so that it will be located in the centre of the wall cavity – see figure 10a. The drip collar can be made by wrapping a non-corrosive wire round the flue or moulding a bead of mastic round the flue.
- **Case fixing to wall:** Offer the fire complete with flue unit through the wall, Insert the four fixing screws and tighten.
- **Cable retention** Fit the eyebolts onto the cables. Thread the cables through the appliance case sides as shown in figure 9a. Offer the fire complete with flue unit through the wall. Pull the cables taut
- **Timber frame building with combustible outer leaf (e.g. shiplap boarding):** A metal or other non-combustible end plate must be fitted on the outside of the wall. The plate must be concentric with the flue and at least 254mm (10in) square or diameter. See figure 10a.
- Seal the outer flue tube to the outside surface of the wall with fireclay or cement. Make sure that the slots in the flue terminal are not closer than 8mm to the wall and are not obstructed by cement.

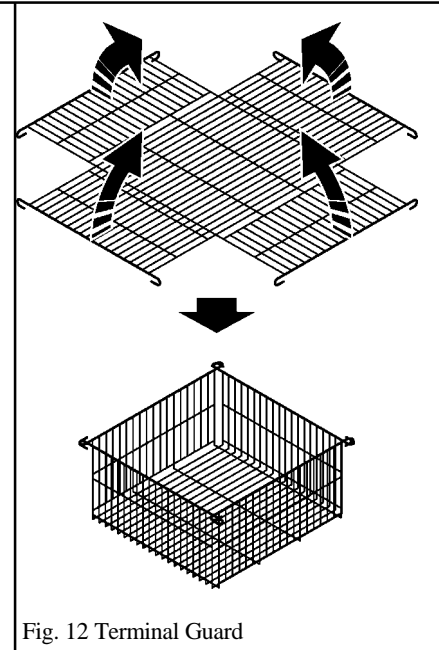
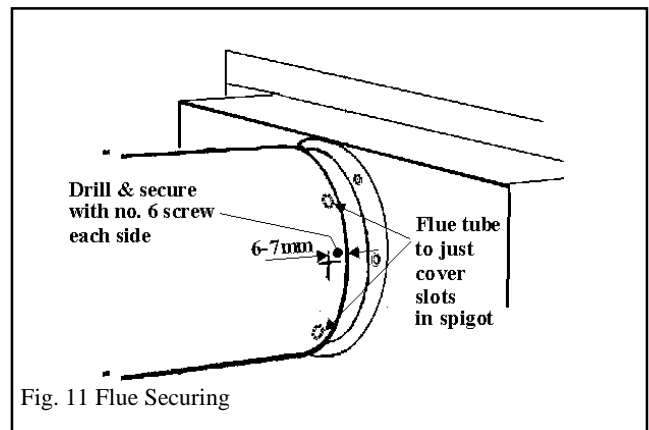

## 6.3 Fitting Terminal Guard

- Fold the terminal guard as shown in figure 12.
- Place the guard centrally over the flue terminal.
- Holding the guard in position and using it as a template, mark on the wall the positions of the four fixing holes.
- Remove the guard. Drill and plug the holes with the four plugs supplied.
- Replace the guard and fix with four woodscrews supplied.

## 7 GAS CONNECTION, FUEL BED & WINDOW FITTING

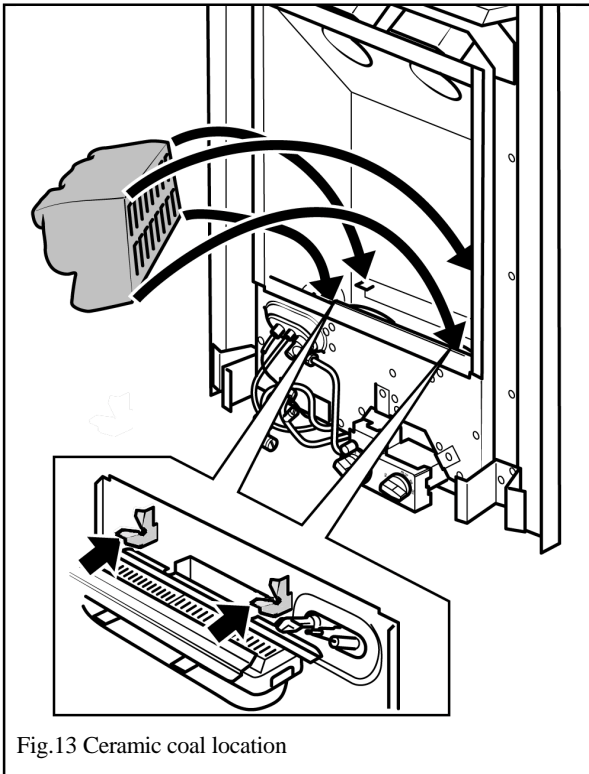

Fig.13 Ceramic coal location

### 7.1 Connect the Gas Supply Pipe

- Complete the supply pipe connection  
**For concealed rear connection**, the pipe run should have been extended as section 4 of this guide. Connect the isolating elbow to the appliance inlet pipe.  
**For Side Connection**, the pipe should be routed to pass through the cut-out at the side of the casting or case. For right side connection, the pipe should also be formed to clear the control unit.
- Pressure test the installation pipework for gas soundness in accordance with the current edition of BS 6891.

### 7.2 Fit the Ceramic Fuel Bed

- Fit the ceramic coal into the fire above the burner. The front of the ceramic coal should locate on the horizontal faces but behind the vertical faces of the two location brackets positioned at the front of the burner module. See figure 13.

### 7.3 Refit the Window

- Locate the channel at the top of the window over the top of the firebox opening.
- Refit the three spring loaded screws and washers. Tighten sufficiently to seal the firebox.
- **Pull the bottom of the window forward and release to check that the window opens slightly and returns in the event of a delayed ignition explosion.**

## 8 FULL OPERATIONAL CHECKS







### 8.1 Check for Leaks

- Turn on the gas supply and check all joints up to the appliance gas tap for gas soundness using a soap solution or leak detection fluid.

### 8.2 Check Control Operation

*If the fire is turned off or the flames go out, wait at least 3 minutes before attempting to relight. A safety device in the control stops the fire being turned back on until it is safe.*

See figure 14

- Depress the bottom half of the rocker switch located at the right side of the appliance case. This should cause the flame control knob (The left-hand control knob) to rotate clockwise until its bar is pointing vertically downwards. A clicking sound will be heard while the flame control knob is rotating.
- Push in the right control knob and, while keeping it depressed, turn anticlockwise through the ignition position marked  and up to the pilot position marked . The spark should light the pilot. The pilot flame can be seen by looking through the gap near the left side of the coal front.
- If the pilot does not ignite, keep the knob depressed for a few seconds to purge air from the supply pipes. Then turn back to the off position marked  and repeat the ignition procedure.
- When the pilot has lit, keep the right hand control knob depressed for a few seconds to allow the pilot flame to stabilise then release it. If the pilot does not remain alight ensure that the air has been purged.
- Partially depress the right control knob and turn to the main burner position marked .
- The left-hand knob is for burner flame adjustment. In its fully clockwise position it turns the main burner off. Depressing top half of the rocker switch should cause the flame control knob to rotate anticlockwise direction. This should light the main burner and gradually increase the flame height. The maximum flame height should be achieved when the bar of the flame control knob is pointing vertically upwards.
- After checking up to maximum flame height, depress the bottom half of the rocker switch until the main burner is extinguished.
- The flame control rocker switch does not have to be operated every time the fire is lit or turned off. The main burner setting will remain at its previously chosen position enabling the customer to use the right hand control only to ignite the burner at that setting and to turn the fire off.
- After checking turn the right hand knob to off. Depress the control knob partially at the pilot position () , turn clockwise to off () and release the knob. If any resistance is felt when turning, release the downwards pressure on the knob before continuing to turn.

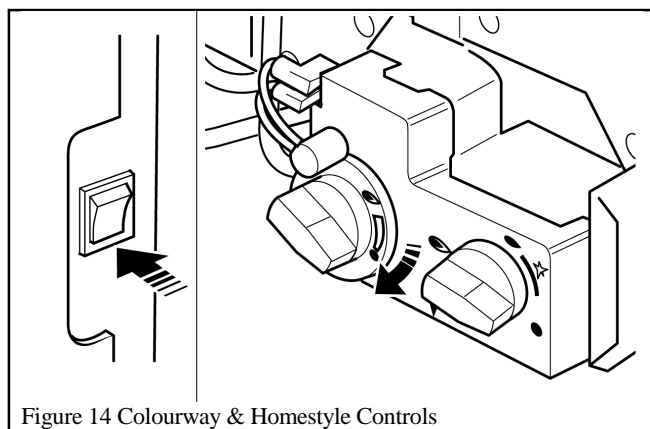

Figure 14 Colourway & Homestyle Controls

### 8.3 Check Reference Pressure

The burner aeration is non-adjustable. The appliance is preset to give the correct heat input on Natural Gas at 20 mbar (8in w.g) inlet pressure and no further adjustment is necessary. The burner pressure should be checked at the pressure test point located on the pipe connecting the gas tap to the main burner (See figure 15). The pressure check should be carried out using a calibrated pressure gauge after removing the test point screw. The fire should be alight and the left hand control knob at its fully anticlockwise setting (Maximum flame height). The pressure setting should be within the limits shown in section 1 of this manual (Appliance data). After checking the pressure, turn off the fire, remove the pressure gauge and replace the pressure test sealing screw. Relight the fire and test all gas joints for soundness using a suitable leak detection fluid.

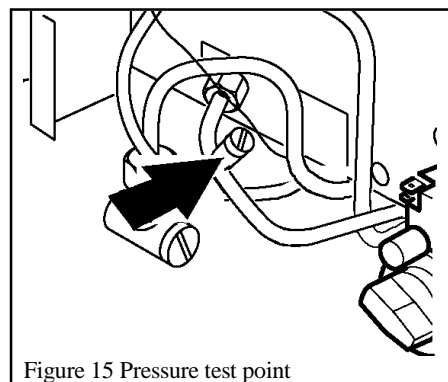

Figure 15 Pressure test point

## 9 FITTING FRONT UNIT

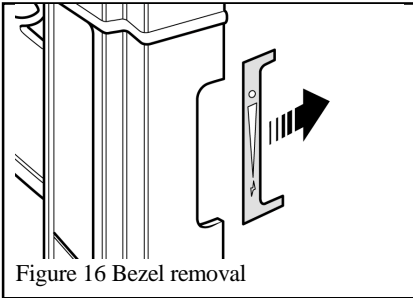

Figure 16 Bezel removal

The front unit pack weighs around 20kg (44lbs). To avoid any risk of injury, if you have any doubt about your ability to safely lift this pack and its contents, ask someone to assist you.

Having assistance when installing this front will also reduce the risk of damaging the front or anything nearby. We suggest that the cardboard packaging or similar is used to protect the fireplace surround and floor.

**The metal brackets, supports, shields and screws contained in the bag supplied with this front are not required for this appliance.**

- The side control bezel is not applicable for this appliance. Remove the bezel from the right side of the front unit by firmly pulling it back from the side casting. See figure 16. Be careful not to scratch the paint.

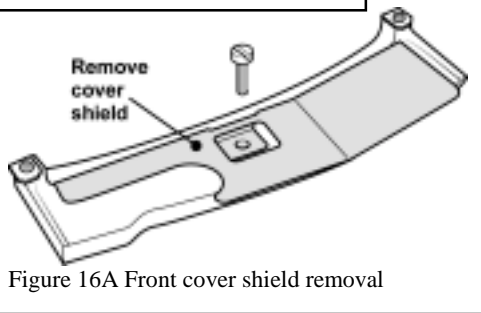

Figure 16A Front cover shield removal

- The shield at the back of the bottom front cover is not applicable for this appliance. It may prevent the front cover from being able to be placed properly in position. Unscrew the knob retaining screw to remove it. See figure 16A.
- Remove the two screws securing the brass finials to the lower cross member of the front casting. Fit the bottom infill apron behind the finial brackets. Secure with the two screws. See figure 17.

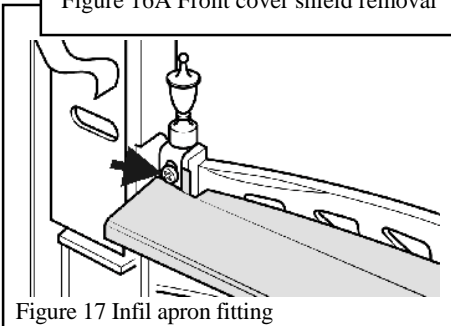

Figure 17 Infill apron fitting

- The front has a location plate at the rear of the mantle shelf and a location bracket near the bottom rear of each vertical column. These locate into the convection box. Carefully lift the cast front into position squarely with the convection box. Holding the cast front a little above the top surface of the convection box, locate the two lower location brackets into the lower case brackets and the upper location plate into the two slots in the upper case support. Gently lower the cast front making sure that it causes no damage to the floor. The cast front should sit squarely on the floor and be evenly spaced each side of the black appliance case surround. See figure 18.

- Fit the bottom front cover.

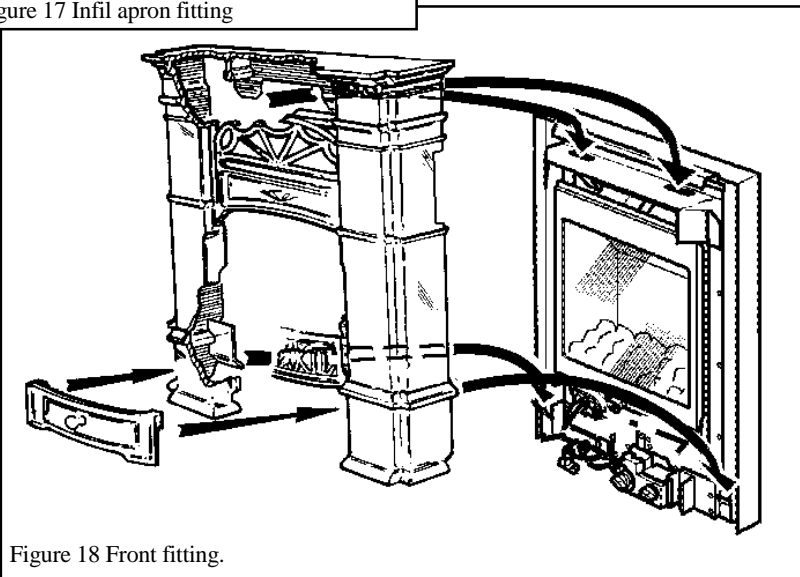

Figure 18 Front fitting.



## 10 FINAL REVIEW

- Recheck the pilot ignition and operation of the fire through the range of settings.
- Visually inspect the appliance. Clean off any marks incurred during installation
- Advise the customer to read their Owner's Guide before operating the fire and to always follow the advice in the section headed "Cleaning Your Fire".
- ***Stress that no loose coals must be added to the ceramic fuel bed supplied with the appliance and that any replacement fuel bed must only be the authorised spare.***
- Advise the customer how to operate the appliance. Take the customer through the full operating sequence step by step. Point out that lighting instruction details are contained on the plate attached at the bottom of the appliance. Leave the plate visible in front of the bottom front cover as a reminder to the customer.
- Advise the customer that the pilot flame can be viewed to ensure that it is alight. Show the user where to view the pilot and point out the illustration in the users instructions showing how to view the pilot.
- Advise the customer that the pilot can be left alight but mention that if the premises are to be left unoccupied for a lengthy period, it is advisable to turn the pilot off.
- ***Emphasise that if the glass panel is broken or damaged, the fire should be turned off and not used until the window unit is refitted with an authorised replacement***
- Recommend that the appliance should be serviced by a competent person (*In the UK preferably a CORGI registered person*) at least annually. *If the appliance is in premises in the United Kingdom occupied by a tenant, point out that by law a landlord must have any gas appliance, flue and pipework which is situated in a tenant's premises checked for safety at least every 12 months*
- Hand over to the customer this guide and the owner's guide.

## 11 SERVICING & PARTS REPLACEMENT

- Always turn off the gas and make sure that the appliance is cool before commencing any servicing. (The inlet elbow on this appliance incorporates an isolating valve)
- Always test for gas soundness after refitting the appliance.
- This product uses a burner compartment wall and gaskets containing Refractory Ceramic Fibres (RCF), which are man-made vitreous silicate fibres. Excessive exposure to these materials may cause temporary irritation to eyes, skin and respiratory tract. Consequently, it makes sense to take care when handling these articles to ensure that the release of dust is kept to a minimum. To ensure that the release of fibres from these RCF articles is kept to a minimum, during installation and servicing we recommend that you use a HEPA filtered vacuum to remove any dust and soot accumulated in and around the fire before and after working on the fire. When replacing these articles we recommend that the replaced items are not broken up, but are sealed within a heavy duty polythene bag, clearly labelled as RCF waste. This is not classified as "hazardous waste" and may be disposed of at a tipping site licensed for the disposal of industrial waste. Protective clothing is not required when handling these articles, but we recommend you follow the normal hygiene rules of not smoking, eating or drinking in the work area and always wash your hands before eating or drinking.

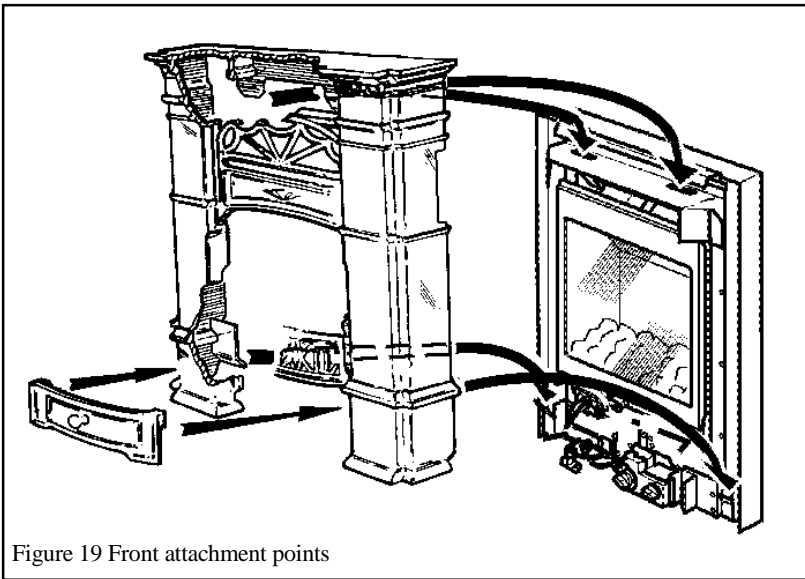

Figure 19 Front attachment points

### 11.1 To Remove Front Unit.

*The front casting weighs around 20kg (44lbs). To avoid any risk of injury, if you have any doubt about your ability to safely lift this front, ask someone to assist you.*

- Remove the bottom front casting.
- Raise the front casting unit so that the bottom location brackets and the top location plate are released from the locations in the main fire case. See figure 19

### 11.2 To Remove Window Unit

- Remove the front unit. See section 11.1.
- Unscrew and remove the three spring-loaded window-fixing screws and washers from the base of the window frame. See figure 20.
- Gently swing the base of the window frame forward while lifting the frame upwards. The window should lift clear of the fire. Put the window in a safe place away from your immediate work area.

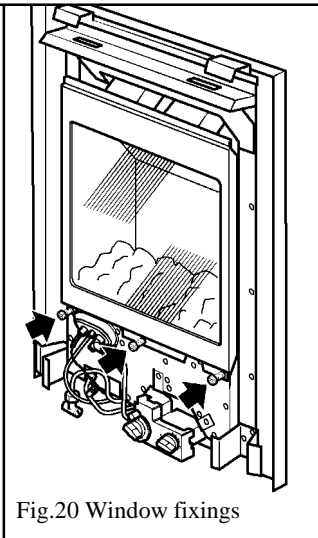

Fig.20 Window fixings

### 11.3 To Remove The Ceramic Fuel Bed & Rear Wall

- Remove the front unit. See section 11.1.
- Remove the window unit. See section 11.2
- Lift out the ceramic fuel bed.
- Remove the rear wall by Carefully sliding it upwards to clear the retaining channel and then swinging the top slightly forwards.

## 11.4 To Remove & Replace the Ceramic Burner plaques

See figure 21

- Remove the front unit. See section 11.1.
- Remove the window unit. See section 11.2
- Lift out the ceramic fuel bed & rear wall. See section 11.3
- Remove the plaque clamping strips by detaching 6 screws.
- Remove the plaques and the combination gasket between and under the plaques. If necessary remove the gauze and the gasket underneath it.
- If necessary fit a new gasket below the gauze. Clean and replace the gauze – make sure that the gas inlet baffle is in the burner can. Fit a new combination gasket below the plaques. Push the gasket ends inwards to form a dividing gasket between the plaques.
- Place the new left hand plaque in position. The left side of the plaque must touch the inside edge of the retaining flange at the left side of the burner well.
- Place the new right hand plaque in position. Make sure that the centre section of the combination gasket is between the two plaques. If there is any play between the plaques and the end retaining flanges, push the plaques firmly to the left squeezing the centre section of the combination gasket between the two plaques. Any gap should be between the right side of the plaque and the right side retaining flange.
- Fit the front and rear plaque clamping strips. The long strip is the front clamp. Make sure that the plaques are as far to the left as possible. *It is important that the left side plaque is accurately positioned so that it has the correct relationship to the pilot.* Fully tighten the clamping strips.

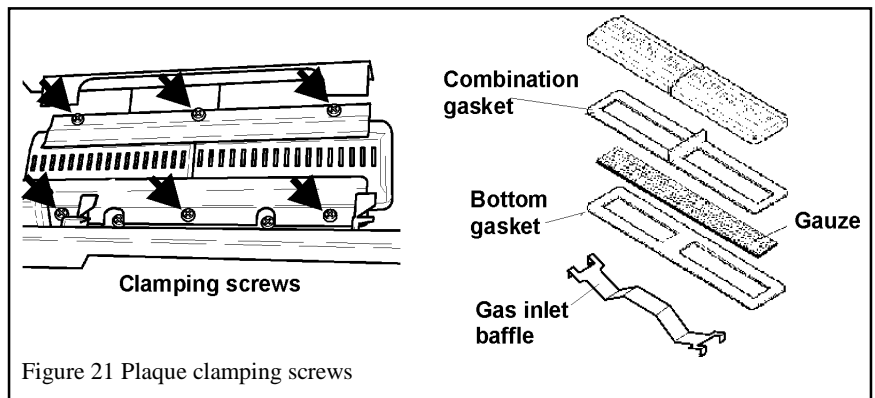

Figure 21 Plaque clamping screws

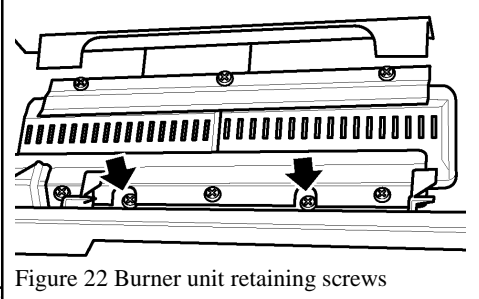

Figure 22 Burner unit retaining screws

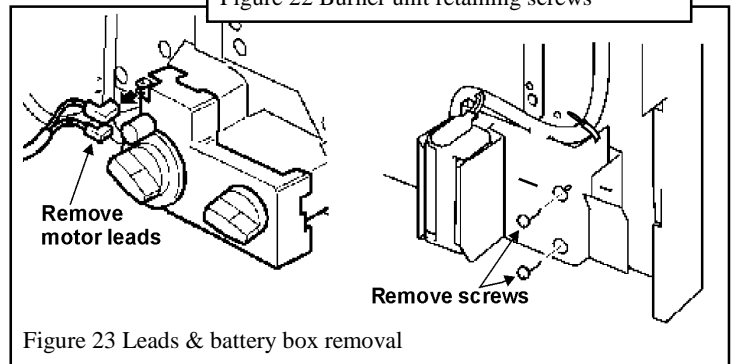

Figure 23 Leads & battery box removal

## 11.5 To Remove Burner Can and Plaque Unit

- Remove the front unit. See section 11.1.
- Remove the window unit. See section 11.2
- Lift out the ceramic fuel bed & rear wall. See section 11.3
- The front plaque clamp has two cutouts. Below these cutouts are two screws. Remove these two screws. See figure 22.
- The burner unit can now be removed. To do this gently manipulate the burner back and forth whilst moving it to the right.
- Replace in reverse order.

## 11.6 To Remove the Complete Burner Module

- Remove the front unit. See section 11.1.
- Remove the window unit. See section 11.2
- Lift out the ceramic fuel bed & rear wall. See section 11.3
- Isolate the gas supply using the inlet elbow on the appliance.
- Unscrew the nut from the top of the inlet elbow
- Disconnect the two motor leads from the top left of the gas valve. See figure 23.
- Detach the battery box from the fire unit by removing two screws. See figure 23.
- Detach the burner front cover by unscrewing the 10 screws at the front of the burner module shown in figure 24.
- Slowly ease the burner module forward and clear ensuring that the thermocouple does not catch on the bottom of the firebox.
- Replace in reverse order.

When replacing, make sure that the wiring loom runs above and to the left of the battery box and behind the control valve. See figure 25. The motor lead connectors are two different sizes. They will only fit to the correct motor terminals.

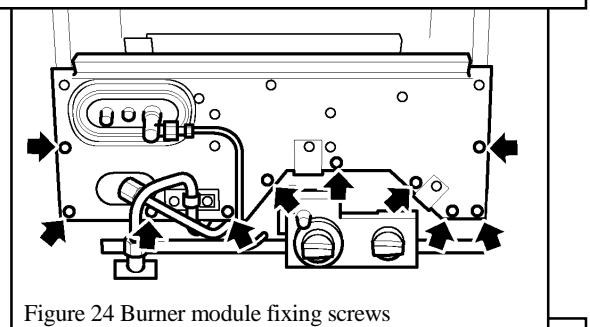

Figure 24 Burner module fixing screws

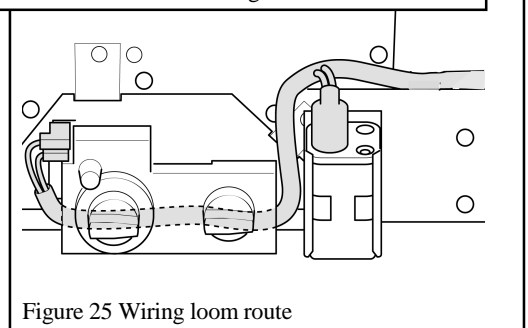

Figure 25 Wiring loom route

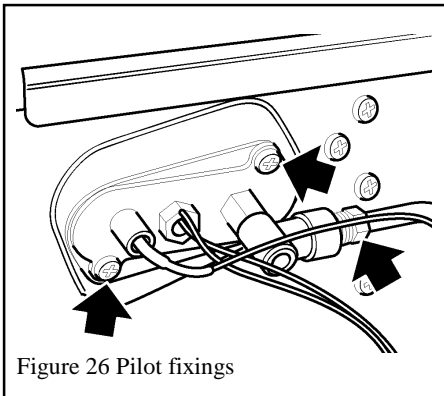

Figure 26 Pilot fixings

### 11.7 To Remove the Injector

- Remove the front unit. See section 11.1.
  - Remove the window unit. See section 11.2
  - Lift out the ceramic fuel bed & rear wall. See section 11.3.
  - Remove the complete burner module. See section 11.6.
  - Detach the burner can & plaque unit by removing the two screws shown in figure 22.
  - Remove the injector from the carrier
  - Replace in reverse order.
- When replacing the injector use a small amount of suitable thread sealant to prevent leakage of gas.
- When replacing, make sure that the wiring loom runs above and to the left of the battery box and behind the control valve. See figure 25. The motor lead connectors are two different sizes. They will only fit to the correct motor terminals.

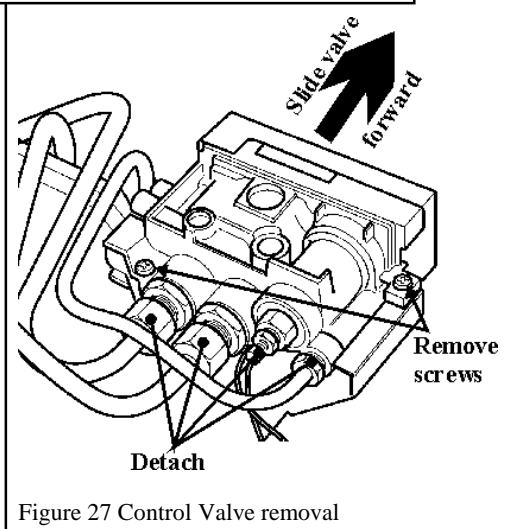

Figure 27 Control Valve removal

### 11.8 To Remove the Pilot Unit

See figure 26.

*Note: The Pilot unit must be replaced as a whole assembly. Its individual components are not separately replaceable.*

- Remove the front unit. See section 11.1.
- Remove the window unit. See section 11.2
- Lift out the ceramic fuel bed & rear wall. See section 11.3.
- Remove the complete burner module. See section 11.6.
- Remove the electrode lead at the pilot. Do this by holding the lead as close to the electrode as possible. This will limit the possibility of damaging the lead connection.
- Unscrew the nut connecting the pilot to the pilot pipe.
- Unscrew the thermocouple at the rear of the gas valve.
- Unscrew the two screws securing the pilot to the module front.
- If the pilot gasket is damaged in any way it must be replaced.
- Replace in reverse order.

When replacing, make sure that the wiring loom runs above and to the left of the battery box and behind the control valve. See figure 25. The motor lead

connectors are two different sizes. They will only fit to the correct motor terminals.

### 11.9 To Remove The Gas Valve

- Remove the front unit. See section 11.1.
- Remove the window unit. See section 11.2
- Lift out the ceramic fuel bed & rear wall. See section 11.3.
- Remove the complete burner module. See section 11.6.
- Remove the electrode lead at the pilot. Do this by holding the lead as close to the electrode as possible. This will limit the possibility of damaging the lead connection.
- Unscrew the thermocouple at the rear of the gas valve.
- Undo the inlet, outlet and pilot nuts on the gas valve.
- Remove the two mounting screws on the underside of the gas valve. See figure 27.
- Remove the valve by sliding it forward.
- Replace in reverse order.

When replacing, make sure that the wiring loom runs above and to the left of the battery box and behind the control valve. See figure 25. The motor lead connectors are two different sizes. They will only fit to the correct motor terminals.

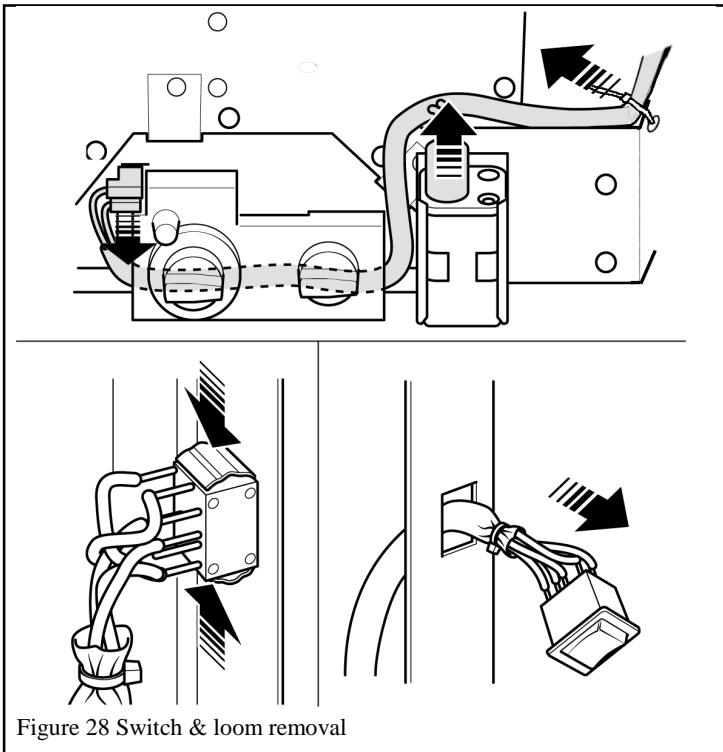

Figure 28 Switch & loom removal

## 11.10 To Remove Switch & Wiring Loom

See figure 28

- Remove the front unit. See section 11.1.
- Disconnect the two motor leads from the top left of the gas valve.
- Cut the cable tie securing the loom to the battery box bracket. Pull the loom out from behind the control valve.
- Detach the two leads from the plastic battery holder.
- Press firmly inwards the two retaining claws on the inside of the rocker switch. Remove the loom through the switch aperture in the surround side.
- Replace in the reverse order.
  - When replacing the switch make sure that the white printing on the switch side faces the back of the fire. If the printing faces the front, pressing the upper half of the switch will lower the flame height.
  - When replacing, make sure that the wiring loom runs above and down to the left of the battery box and behind the control valve. See figure 25.
  - Secure the loom to the battery box bracket with the cable tie supplied with the new loom – check that there is sufficient free length of loom wire to allow the battery holder to be removed from & replaced in the battery box before securing the cable tie.
  - The motor lead connectors are two different sizes. They will only fit to the correct motor terminals.

## 11.11 Short List of Spares

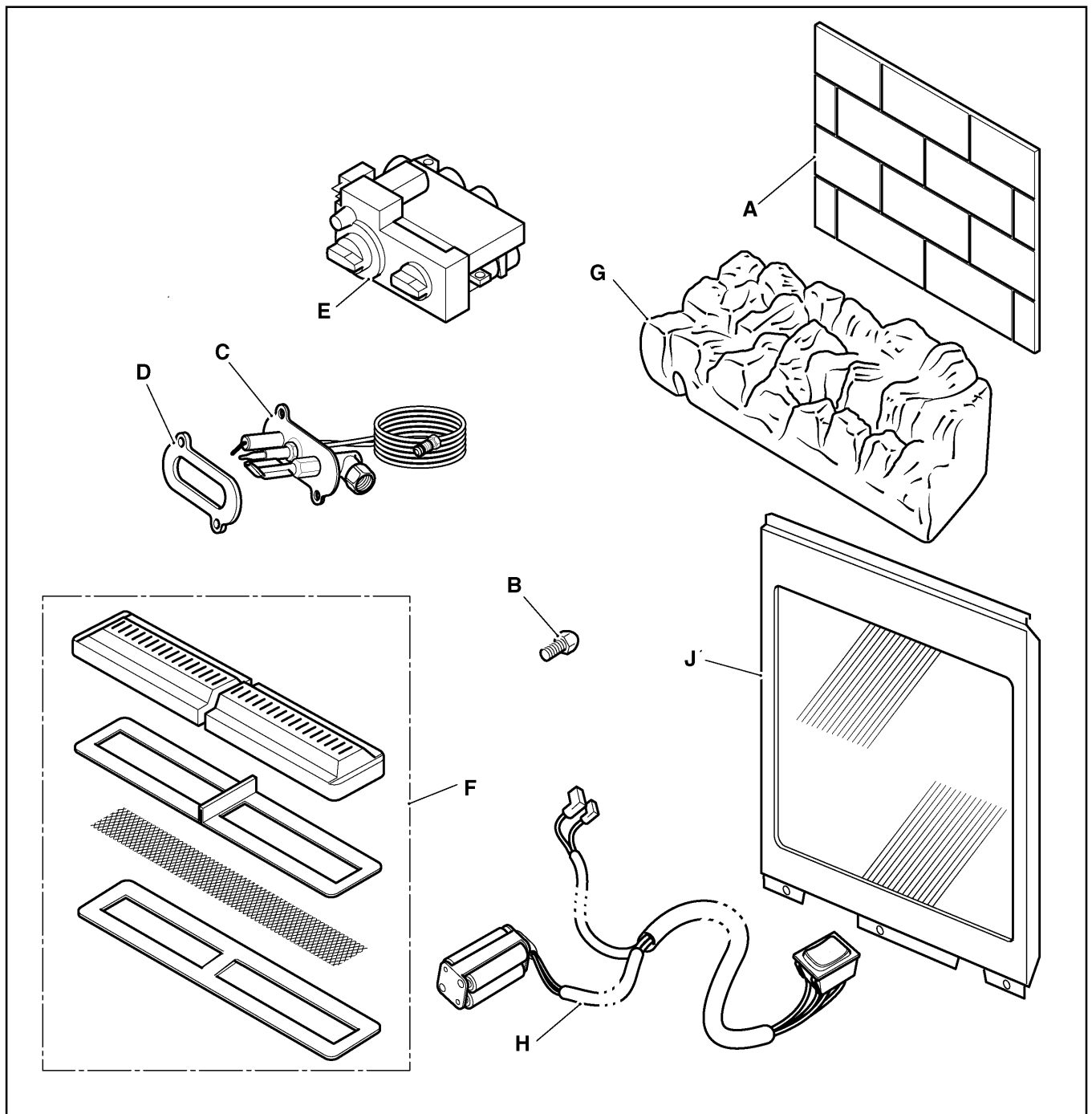

Key	Description	No. Off	Part No.
A	Ceramic rear wall	1	571789
B	Injector-Main burner – Bray Cat.960 Size 270	1	571799
C	Pilot Unit SIT Ref. OP9706	1	571809
D	Pilot Gasket	1	571819
E	Control valve	1	571859
F	Burner plaque & gasket set	1	569439
G	Ceramic fuel bed	1	571839
H	Switch & wire loom	1	571869
J	Window unit	1	571849

All Wonderfire appliances are CE Approved and designed to meet the appropriate British Standards.



All Wonderfire appliances are manufactured to the highest standards of quality and excellence under the BS EN ISO 9001 quality system accepted by the British Standards Institute.

All Wonderfire gas appliances must be installed by a competent person in accordance with the Installer Guide. If in doubt always use the services of a CORGI Registered Installer

Please fill in the following information for your own future reference. The information should always be quoted in any correspondence with your original supplier or Wonderfire service department.

In the United Kingdom please telephone **0121 386 6203**.

In the Republic of Ireland please telephone **353 183 75114**

Model **Lincoln Model 5403**

Supplier's Name

Supplier's Address

Telephone No.

Date of Purchase

Guarantee Card No.



MANUFACTURED BY WONDERFIRE  
Wood Lane, Erdington, Birmingham B24 9QP

Because our policy is one of constant development and improvement, details may vary slightly from those given in this publication