



**Masters of the living flame.**

**I N S T A L L E R   G U I D E**



**VALOR COSYFLAME  
TURBOCHIM\*  
(MODEL 528)  
VALOR SECRET  
TURBOCHIM\*  
(MODEL 527)  
&  
HEARTHMASTER  
(MODEL 527w)  
Rear Fan Flued  
Inset Gas Fires  
with Live Fuel Effect**

*\*Patent applied for*

***Please keep in a safe place for future reference***

**Please leave this Installer Guide with the user**

This appliance is for use with natural gas (G20)  
This appliance is for use in the United Kingdom  
(GB) and the Republic of Ireland (IE) only.

**C U S T O M E R C A R E**

This Installer Guide gives sufficient details to enable the appliance to be installed and maintained. If further information is required, our **Valor AdviceLine** will be pleased to help.

**Please telephone 0345 626341** (Local call rates apply)

# C O N T E N T S

PART1: APPLIANCE DATA .....	4
PART2: GENERAL INSTALLATION REQUIREMENTS .....	4
PART 3: UNPACKING.....	9
PART 4: PREPARING FOR INSTALLATION .....	10
PART 5: WALL PREPARATION .....	10
General .....	10
Brick, Stone Etc. Building. Main Case In Front Of Wall .....	10
Brick, Stone Etc. Building. Main Case Recessed Into Wall.....	11
Timber frame building. Firebox in front of wall.....	11
Wall preparation for flue tube. ....	12
Core drilling.....	12
Hammer and chisel cutting.....	12
Fixing the appliance in position .....	13
Provision for main loom.....	13
Prepare flue assembly .....	13
PART 6: INSTALLATION OF ELECTRICS, FIREBOX AND FAN BOX .....	14
Securing firebox to wall - cable retention.....	15
Securing firebox to wall using fixing brackets.....	15
Fan box installation .....	16
Electrical installation .....	17
Refit the burner unit .....	17
Electrical test.....	18
Terminal guarding.....	18
PART 7: GAS SUPPLY INSTALLATION .....	19
Preliminary Burner Checks .....	19
Check Reference Pressure .....	20
PART 8: FITTING THE CERAMICS.....	20
PART 9: CHECKS.....	22
Recheck Control Settings.....	22
Check for spillage.....	23
Flame supervision & spillage monitoring system .....	23
PART 10: FRONT CASTING ASSEMBLY & FINAL REVIEW .....	24
Front casting assembly for model 527 .....	24
Final review.....	24
PART 11: SERVICING PARTS AND REPLACEMENT .....	25
To replace the burner plaques .....	25
To Remove The Pilot Unit .....	25
To Completely Remove The Burner Unit.....	26
To Remove The Gas Tap/F.S.D & Solenoid Assembly.....	26
To Remove The Piezo Generator.....	26
To Remove The Main Burner Elbow Injector.....	26
To Remove an “On” or “Off” Switch .....	26
To Gain Access to the Electrical Control Components .....	27
To Remove the Distribution block.....	27
To Remove the Fan.....	27
To remove the pressure switch .....	27
Pressure switch strip down .....	27
Short List Of Spares.....	28

## PART1: APPLIANCE DATA

This appliance does not contain any component manufactured from asbestos or asbestos related products.

The appliance data label and wiring diagram are on a plate chained below the burner and visible when the control cover is removed.

Gas:	Natural (G20)
Inlet pressure:	20mbar (8in w.g.)
Gross input:	Max. 6.0kW (20,500 Btu/h) Min.2.2kW (7,500Btu/h)
Burner test pressure (cold):	18.2±0.75mbar (7.3±0.3 in w.g.)
Gas connection:	8mm pipe
Burner injector:	Bray cat. 82 size 360
Pilot & atmosphere sensing device:	SIT ref. OP9044
Ignition:	Piezo electric. Integral with gas tap
Aeration:	Non-adjustable
Electrical supply:	230V ~ 50Hz AC
Fan motor rating:	55W
Fuse rating:	3A 

## PART2: GENERAL INSTALLATION REQUIREMENTS

The installation must be in accordance with these instructions.

For the user's protection, in the United Kingdom it is the law that all gas appliances are installed by competent persons in accordance with the current edition of the Gas Safety (Installation and Use) Regulations. Failure to install the appliance correctly could lead to prosecution. The Council for the Registration of Gas Installers (CORGI) requires its members to work to recognised standards.

In the United Kingdom, all electrical supply installation must be installed in accordance with the current edition of the IEE Wiring Regulations (BS7671).

In the United Kingdom the installation must also be in accordance with:

- All the relevant parts of local regulations.
- The current edition of the Building Regulations issued by the Department of the Environment and the Welsh Office or the Building Standards (Scotland) (Consolidation) Regulations issued by the Scottish Development Department.

All relevant codes of practice.

- The relevant parts of the current editions of the following British Standards:-  
BS 5440 Part 1  
BS 5871 Part 2 & 3  
BS 6891

In the republic of Ireland the installation must also conform with:

- The current editions of:-  
IS 813  
ICP3
- All relevant national and local rules in force.
- The current ETCI National Rules for Electrical Installation.

Electrical isolation of the unit should be by means of a switched 3A fuse spur that should be readily accessible to the user, easily identifiable and sited within reach of the mains cable provided. It should only connect this appliance.

This fire is a fan flued appliance for installation on an outward facing wall of a conventional home which does not have a purpose built flue or chimney.

As supplied, the appliance is suitable for homes constructed of brick, stone, etc., the appliance can be installed into walls up to a maximum thickness as shown below.

If the fire box is in front of the finished wall surface: 600mm (23 5/8in) max.

*These dimensions are from the finished internal wall surface (including any surround material) to the external wall surface.*

Installation to a timber framed building should be in accordance with the relevant sections of Institute of Gas Engineers publication IGE/UP/7 "Gas installations in timber frame buildings". **Please note that advice should be sought before installing in a timber frame building since the alterations required may nullify any NHBC cover relating to the property. If in doubt, guidance should be requested from your local authority planning or building department.**

This appliance must be mounted with a non-combustible hearth (N.B. conglomerate marble hearths are considered as non-combustible). The fire box must be mounted on a non-combustible surface level with the hearth. The hearth must project at least 345mm forward of the fire box front and be at least 625mm wide (see illustrations in "wall preparation" section). The hearth material must be at least 12mm thick. The periphery of the hearth (or fender) should be at least 50mm above floor level to discourage the placing of carpets or rugs over it.

The surface of the hearth must be sufficiently flat to enable the bottom of the front casting to be aligned horizontally. Any excessive unevenness (uneven tiles, Cotswold stone, etc.) should be rectified.

**The appliance must not stand on combustible materials or carpets.**

**The appliance must not be fitted directly against a combustible wall.** If the appliance is to be fitted against a wall with combustible cladding or skirting board, such materials must be removed from the area covered by the metal outer surround of the appliance. We suggest that the actual surround is used as a template to mark the area for combustible cladding removal.

The appliance can be fitted to a purpose made proprietary class "O" 150°C surround. The opening in the surround or wall recess for the fire box must be within the limits shown in figure 1.

The front face of the wall should be reasonably flat over the area which will be covered by the fire box top and side flanges to ensure a good seal. The minimum height from the top surface of the hearth to the underside of any shelf made from wood or other combustible materials is as follows:-

- For a shelf up to 150mm deep  
Minimum height = 750mm.
- For a shelf deeper than 150mm  
Minimum height = 750mm + 12.5mm for every 25mm depth over 150mm.

Note that soft wall coverings (e.g. embossed vinyl, etc.) are easily affected by heat. They may scorch or become discoloured when close to a heating appliance. Please bear this in mind when installing.

The appliance must not be installed in any room which contains a bath or shower or where steam is regularly present.

An extractor fan may only be used in the same room as this appliance, or in any area from which ventilation for the appliance is taken, if it does not affect the safe performance of the appliance. Note the spillage test requirements detailed further on in this manual. If the fan is likely to affect the appliance, the appliance must not be installed unless the fan is permanently disconnected, or provision is made to ensure that the fan and the appliance cannot be used at the same time.

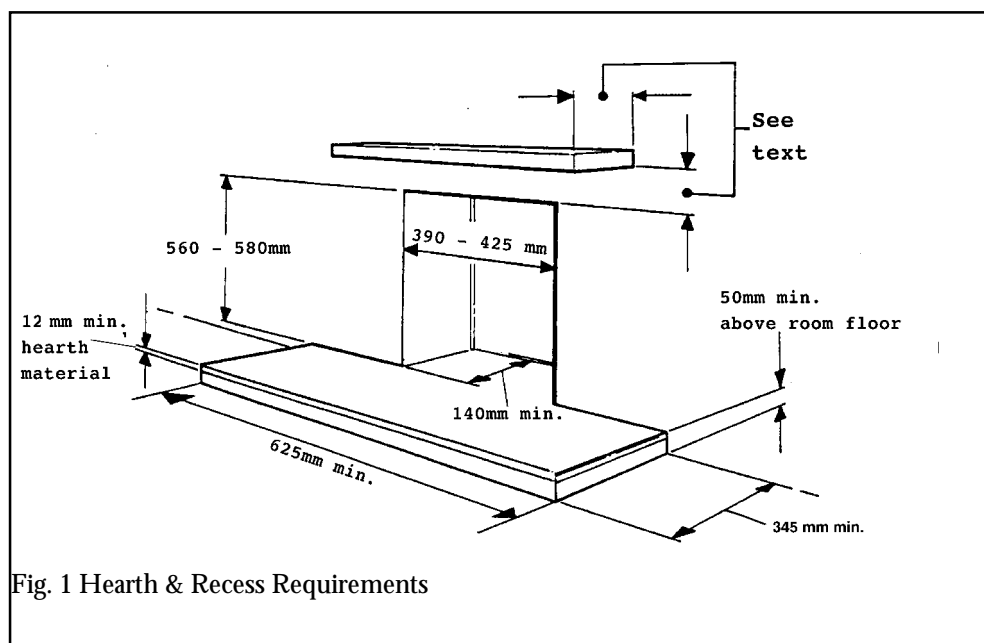

Fig. 1 Hearth & Recess Requirements

A fan-powered flue system tends to depressurise the room containing the appliance. Normally no additional ventilation should be required. In exceptional circumstances, however the spillage check (See further on in this guide) may indicate a need for further ventilation in order to ensure that there is adequate air replacement. If necessary seek expert advice.

In the Republic of Ireland (IE), permanent ventilation must comply with the rules currently in force.

The flue terminal should be located so that the wind can blow freely across it at all times and where any blockage due to leaves, snow, etc. is unlikely. The minimum allowable distances from the terminal are shown in figure 2 and the table.

*Note: The distances are from the edge of the vertical exit slots in the terminal not from the edges of the rectangular box (See figure 2).*

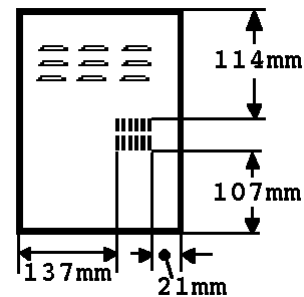
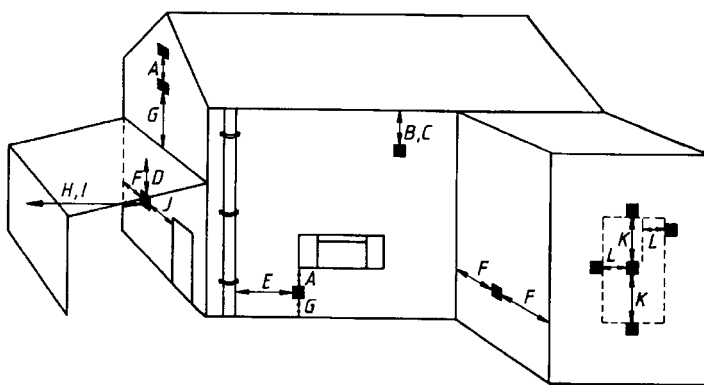

Minimum distances for terminal positions shown in the table are from slot openings.

Dimension	Terminal Position	Minimum Distance
A	Directly below an opening, air brick, windows, etc.	300mm
B	Below gutters, soil pipes or drain pipes	75mm
C	Below eaves	200mm
D	Below balconies or car port roof	200mm
E	From a vertical drain pipe or soil pipe	75mm
F	From an internal or external corner	200mm
G	Above ground, roof or balcony level	300mm
H	From a surface facing the terminal	600mm
I	From a terminal facing the terminal	1200mm
J	From an opening in a car port (e.g. door, window) into dwelling	1200mm
K	Vertically from a terminal on the same wall	1500mm
L	Horizontally from a terminal on the same wall	300mm
-	Projection outwards from wall	55mm

Fig. 2 Allowable Terminal Positions

This appliance is supplied with a terminal guard. In England and Wales, the Building Regulations require that the terminal guard is fitted if the flue terminal can come in contact with people near the building or be subject to damage. Even if the regulations do not demand it, we recommend that the guard is fitted to prevent damage or blockage of the flue system by leaves etc.

A concealed gas supply connection can be made through the rear panel. Visible front connection can be from the left or right side.

Electrical connection is from the left side.

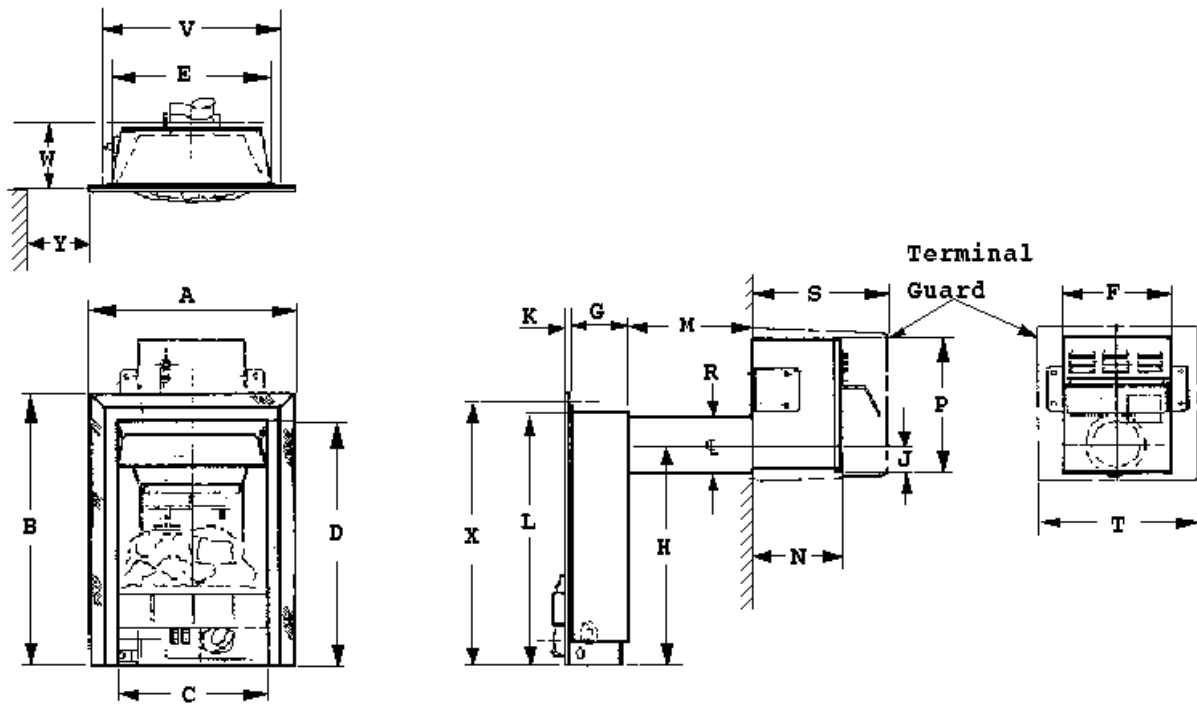

A	470mm
B	600mm
C	325mm
D	525mm
E	350mm
F	235mm
G	125mm
H	475mm
J	53mm
K	5mm
L	550mm
M	600mm max. (Flue tube uncut) 150mm min.
N (Fan box projection)	205mm when sited outside wall 55mm when recessed in outer wall
P	285mm
R (Flue tube diameter)	125mm
S (Terminal guard projection)	305mm
T	355mm
V (Recess width)	390mm min. 425mm max.
W (Recess depth)	140mm min.
X (Recess height)	560mm min. 580mm max.
Y (Clearance to wall etc. projecting forward of appliance firebox)	190mm min.

Fig. 3 Appliance dimensions



## PART 3: UNPACKING

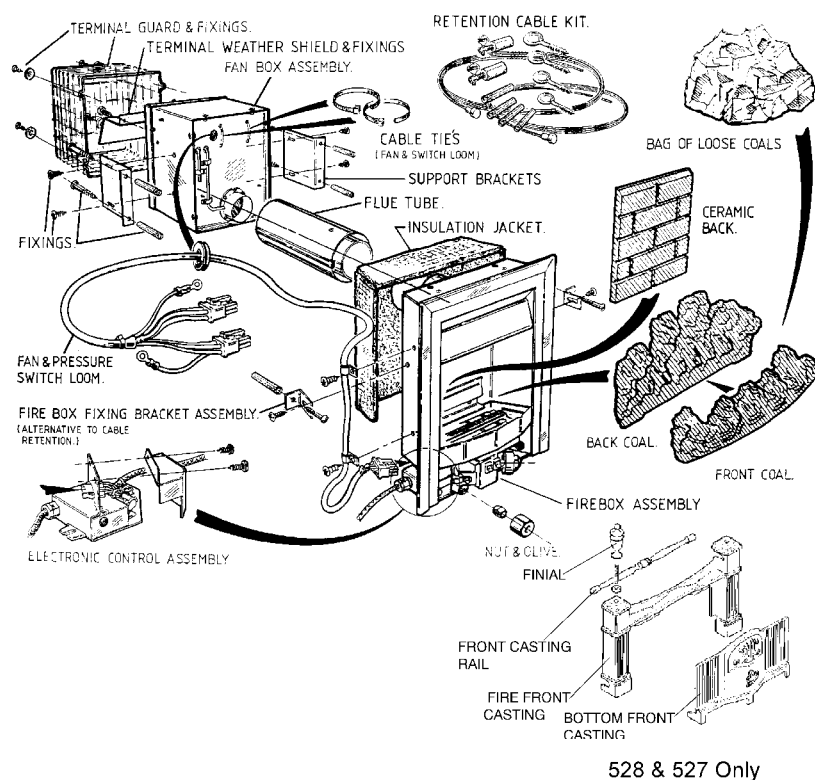

528 & 527 Only

Fig. 4 Appliance units

The pack contains:

- |  |  |
|--|--|
| <ul style="list-style-type: none"> <li>1 Burner &amp; firebox unit with attached Rockwool jacket</li> <li>1 Fan box assembly</li> <li>1 Flue duct</li> <br/> <li>1 Ceramic back wall</li> <li>1 Front base coal</li> <li>1 Rear base coal</li> <li>1 Pack of 9 loose coals</li> <br/> <li>1 Terminal weather shield</li> <br/> <li>1 Fire front casting</li> <li>2 Casting finials, bolts &amp; nuts (model 527)</li> <li>1 Front casting rail (model 527)</li> <li>1 Bottom front cover casting</li> <br/> <li>1 Template</li> <li>1 Literature pack</li> <li>1 Smoke match tube</li> <li>1 Fan and pressure switch loom</li> <br/> <li>2 Rolls aluminium tape</li> </ul> | <ul style="list-style-type: none"> <li>1 Nut &amp; olive for 8mm inlet pipe</li> <li>1 Retention kit ( 4 wall plugs, 4 eye bolts, 2 tension adjusters and two cable assemblies).</li> <li>10 Wall plugs</li> <li>10 Woodscrews</li> <li>2 Taptite screws (For fan box)</li> <li>1 Rockwool jacket top section</li> <li>2 Cable ties</li> <li>1 Firebox fixing bracket assembly (2 brackets, 4 "P" clips &amp; 6 self tapping screws)</li> <li>1 Terminal guard fixing assembly (4 screws &amp; washers ) (Terminal guard in separate pack)</li> </ul> <p>Carefully remove the contents. Take special care in handling the ceramic fireback and the coals. Check that the listed parts are present and in good condition.</p> |
|--|--|

## PART 4: PREPARING FOR INSTALLATION

True gap  
3.0-5.0 mm

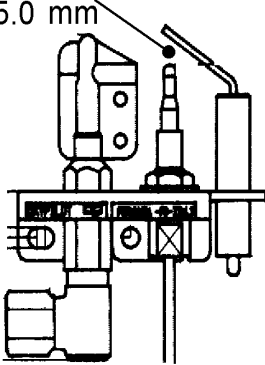

Figure 5 Pilot Ignition System

### Check ignition spark

Before attempting to install, it is worth checking that the piezo electric spark ignition system operates satisfactorily.

To initiate the spark, depress the control knob and while keeping it depressed, turn anticlockwise through approximately 60° to the "PILOT/IGN" position. A spark should track from the electrode pin to the thermocouple tip. If there is no spark or incorrect tracking, check the spark gap between the electrode wire and thermocouple tip (see figure 5). If the spark gap is correct, check the ignition wiring.

In the majority of cases, the burner unit will need to be detached. (see page 26) Detach the burner unit from the firebox, by removing the support bracket fixing screw at the lower front region of the burner unit. Lift and withdraw the unit. (See figure 6).

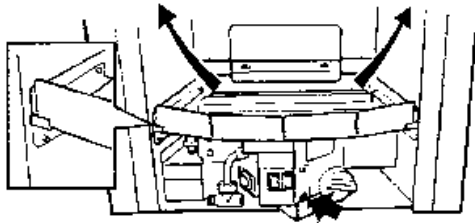

Fig. 6 Burner unit removal

## PART 5: WALL PREPARATION

### General

Make sure that the installation will comply with all the relevant requirements in part 2 of this manual.

Attempt to keep the hole sizes as close to the minimum dimensions as possible in order to minimise the sealing required

Make sure that the or any electrical wiring, piping etc. in the wall is not affected when cutting the installation hole.

Any gas supply pipe installed in the wall, floor or cavity of a cavity wall must be continuous and enclosed in a factory fitted gas tight sleeve (Ref: Gas safety (Installation & Use) Regulations 1994 as amended & Certificate of exemption no.1 1996)

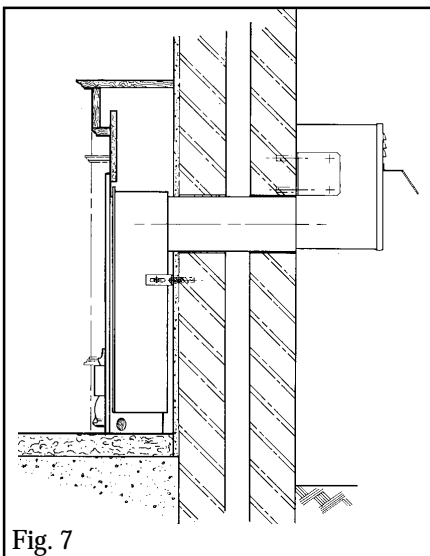

Fig. 7

### Brick, Stone Etc. Building. Main Case In Front Of Wall (Figure 7)

This installation is for use with a fire surround or false chimney breast having a minimum depth of 140mm (5¼in.). The flue length may be cut to suit the wall thickness. (see prepare flue assembly section) Combustible material within a false chimney breast must be at least 75mm from the fire box.

The non-combustible hearth must project at least 345mm in front of the convection box front flanges and be at least 625mm wide (Figures 1 & 7).

The cavity should be sealed where the flue tube hole has been cut. We recommend filling fully across the cavity with Rockwool or equivalent to at least 100mm around the opening. (See figure 11 )

## Brick, Stone Etc. Building. Main Case Recessed Into Wall (Figure 8)

This installation has the fire box recessed into the inner wall of the building. The front flanges of the fire box and the appliance metal decorative surround will abut the front surface of the wall.

The non-combustible hearth must project at least 345mm in front of the convection box front flanges and be at least 625mm wide (Figure 1).

The recess in the inner wall for the fire box should be to the size shown in figure 1. The bottom of this recess should be at the same level as the top surface of the hearth.

**A lintel may be required above the recess for the fire box. If in doubt, seek expert building advice before commencing to cut the recess.**

Whenever a lintel is required to support the recess in the inner leaf of a brick/blockwork building, follow the method outlined below. See figures 9 and 10.

1. The lintel should be either steel (Catnic) or reinforced precast concrete. It should be 750mm long x 75mm deep x inner leaf thickness.
2. The opening should be, as near as possible, centrally below a joint in the inner leaf block.
3. Cut out the opening for the lintel.

Where cutting through masonry, drill pilot holes and then cut out the slot using a mechanical cutter. This will minimise damage to the surrounding structure.

4. Insert the lintel. Bed the lintel on mortar. **Don't dry bed.** Slate pin to ensure the lintel and structure above is secure and safe

5. Make the opening below the lintel by removing the masonry and clearing debris. If the cavity has loose fill (e.g. granular) insulation material, pack the edges of the opening with Rockwool as you proceed to hold back the insulating material.

The wall cavity must not be bridged other than by the flue tube assembly. The fire box must not project into the cavity between the inner and outer walls by more than 10mm.

**See wall preparation for flue tube.**

The cavity should be sealed where the opening has been cut. We recommend filling fully across the cavity with Rockwool or equivalent to at least 100mm all around the flue tube. Fill at the bottom of the opening to the level of the hearth/fireplace floor. It may be simplest to back fill the cavity with the insulation material and then cut through the insulation to the size of the flue box hole.

## Timber frame building. Firebox in front of wall

This installation is for use in timber framed buildings in conjunction with a fire surround having a minimum depth of 140mm (5 5/8in).

The non-combustible hearth must project at least 345mm in front of the convection box flanges and be at least 625mm wide. For this type of installation the hearth must be at least 50mm thick over its total area. (Figure 1).

Installation must be in accordance with the current edition of Institute of Gas Engineers publication IGE/UP/7.

The back surface of the firebox and flue tube assembly must be separated from the timber frame by 25mm of non-combustible material. This can consist of the usual 13mm plasterboard wall lining plus 12mm of "Superlux" or similar non-combustible material. The opening should be between studs.

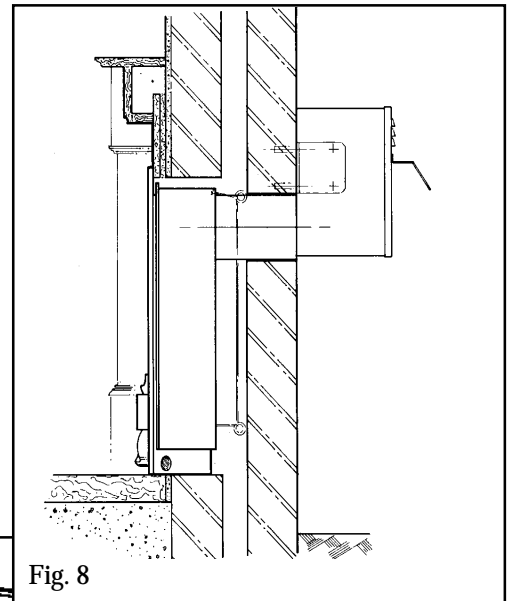

Fig 8

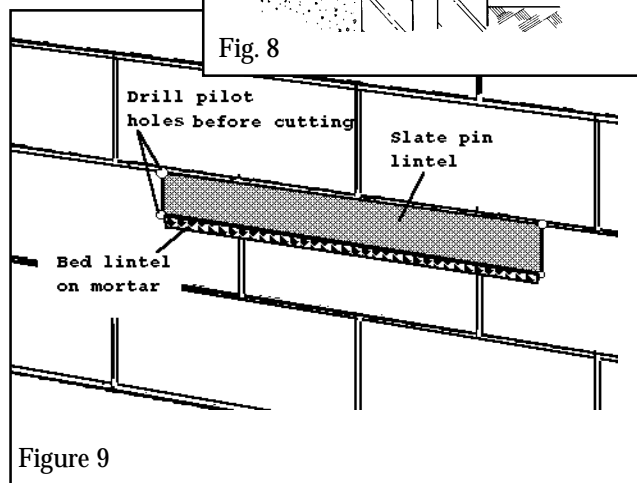

Figure 9

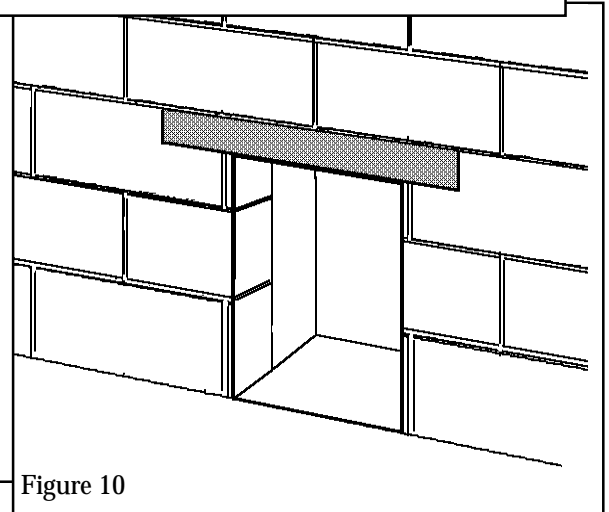

Figure 10

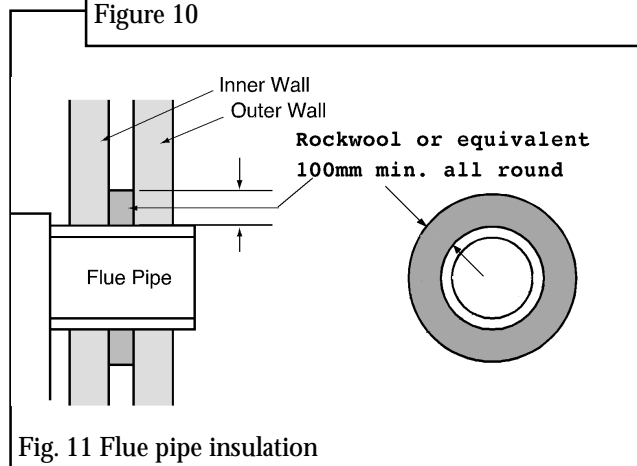

Fig. 11 Flue pipe insulation

## Wall preparation for flue tube.

The flue must be installed so that it is at right angles to the back panel of the fire all round the flue circumference. The fire itself should be fitted vertically against a flat wall. Where this is difficult to achieve due to building inaccuracies care should be taken to ensure that the back of the fire is not stressed in any way due to distortion of the assembly when tightening the fixing screws. Where necessary, non-combustible packing pieces should be used to provide a satisfactory fixing surface.

Before cutting the hole in the wall make sure that the height to the top surface of the finished floor is known. The height from this surface to the flue hole centre is shown in figure 13.

If a loose hearth or plinth is to be used, the height from its top surface must be used when determining the flue height.

Place dust sheets on the floor and over any furnishings etc.

Make sure that the centre of the flue hole is as shown in figure 13.

Now cut the hole for the flue unit.

## Core drilling

Drill a pilot hole through the wall. Inspect the hole to ensure that it is in the brickwork and not in mortar. If it is in mortar, it is advisable to reposition the hole approximately 25mm away (Ensuring that all other clearances to firebox are complied with.).

Remember to reposition the screw fixing holes.

Drill the flue hole with a 5in. (127mm) core drill.

Remove any combustible wall cladding material from the area behind the firebox as described previously.

## Hammer and chisel cutting

Mark a 127mm (5in) diameter circle for the flue hole. Chisel out the area marked.

It may be necessary to make good both the internal and external wall faces. To achieve a neat finish and to make any future removal of the flue unit easier, it is recommended that a cardboard cylinder is formed around the flue unit and inserted in the hole whilst making good. Remove the cardboard cylinder after making good.

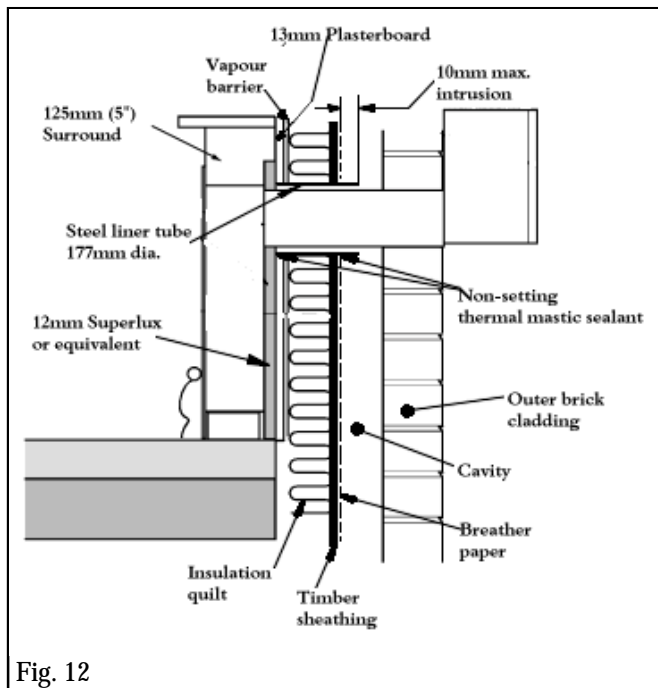

Fig. 12

## Combustible walls (wood, fibreboard, plasterboard etc.)

Building regulations require that the outer surface of the flue tube and terminal must not be closer than 25mm to combustible material and must be lined with steel sleeve not less than 0.5mm thick. (see figure 12). The sleeve can be made by coiling a piece of sheet steel to between 125mm & 127mm outside dia. and fitting it to the combustible parts of the construction.

Mark out and cut a hole 177mm diameter through the plasterboard. Cut a hole of about 165mm in the vapour barrier. Clear the insulation quilt from the hole area and cut a 177mm dia. hole in the timber sheathing and breather paper. Drill a 127mm diameter hole through a non-combustible (brick etc.) outer wall.

Fit the steel sleeve. The sleeve should not protrude more than 10mm into the cavity. The sleeve should be sealed to the inner leaf of the wall at both ends with a non-setting thermal mastic sealant.

If the outer wall is combustible drill a 177mm hole and fit the liner sleeve through to this wall.

Cover the hole with a steel plate size 500mm x 235mm, not less than 1.5mm thick with a 127mm diameter hole in the

middle. Fix with suitable screws and plugs.

Where the whole wall is of combustible material a non-corrosive plate 455mm square with a 127mm diameter hole in the centre must be fitted to the outer face of the wall.



## PART 6: INSTALLATION OF ELECTRICS, FIREBOX AND FAN BOX

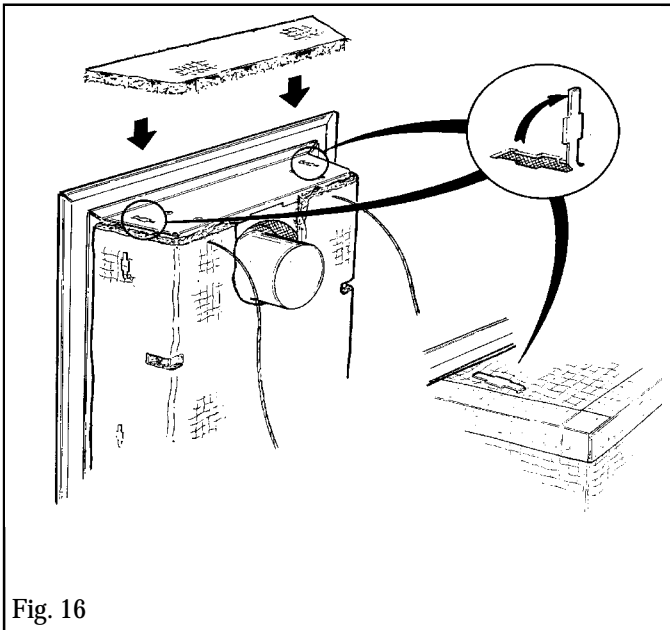

Fig. 16

**Important :** Under no circumstances should the electrical loom be fed between the inner and outer sections of the flue tube.

Obtain the wiring loom and lay the loom through hole in the wall ensuring that the end with two connectors and earthing tags is outside the building.

Ensure the Mains electrical supply to the appliance is in place **and is isolated**.

**Important :** We strongly recommend that a dust mask and protective gloves are worn in order to minimise exposure to Rockwool fibre whilst fitting the insulation jacket .

Ensure the Rockwool insulation jacket is securely positioned on the back of the firebox.

Fit the top part of the jacket to the top of the firebox by securing with two tags as shown below in fig. 16.

**Note :** Use aluminium tape provided to seal adjoining edges of the jacket as shown, unless cable fixing method is to be used, in which case, tape up

**after cables are in position.**

Now connect the wiring loom at the firebox end, the eight pin connector is located on the lower left hand side of the appliance. Take two 'P' clips from the loose parts bag, and use them to secure the loom to the upper left hand side of the firebox. Two fixing holes can be found in this area of the firebox.

Use the fixing screws provided and now secure the 'P' clips and the loom over the top of the insulation jacket ensuring that approximately 250mm of slack exists between the eight pin connector and the first 'P' clip.

***This slack is necessary to allow removal of the electrical control unit in future servicing.***

Obtain the previously prepared flue tube and attach to the spigot on the back of the firebox.

***Ensure that the flue pipe is not fitted in reverse. i.e. The stepped end is the firebox end.***

Now offer the complete assembly as a unit to the wall.

Take care not to damage the wiring loom as the flue pipe is inserted through the wall.

Now it is necessary to secure the firebox to the wall.

## Securing firebox to wall - cable retention

Assemble retention cables into firebox. Insert cables into cable anchor points in upper rear of firebox and then tape together adjoining edges of the jacket as shown in figure 16. Offer the firebox up to the wall and feed the retention cable through the installed eyebolts. Return the cables through the holes provided at the lower back of the firebox. Assemble adjusters and tension as in figure 17.

## Securing firebox to wall using fixing brackets

Loose assemble the two fixing brackets provided (see figure 18) using the screws provided. Offer fire up to wall. Establish the final location of firebox, and secure fixing brackets accordingly. Mark off the wall, drill two holes using no.10 drill bit. Insert wall plugs. Firebox is now ready to secure using wood screws provided.

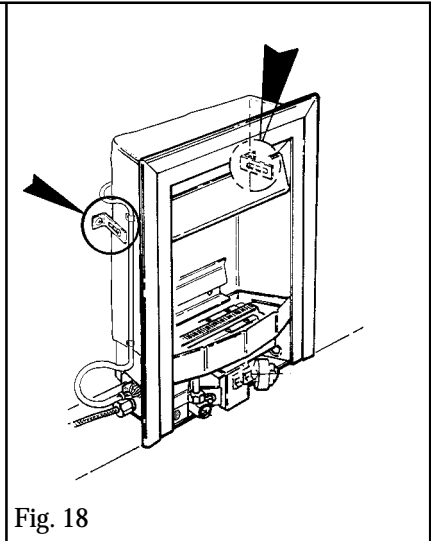
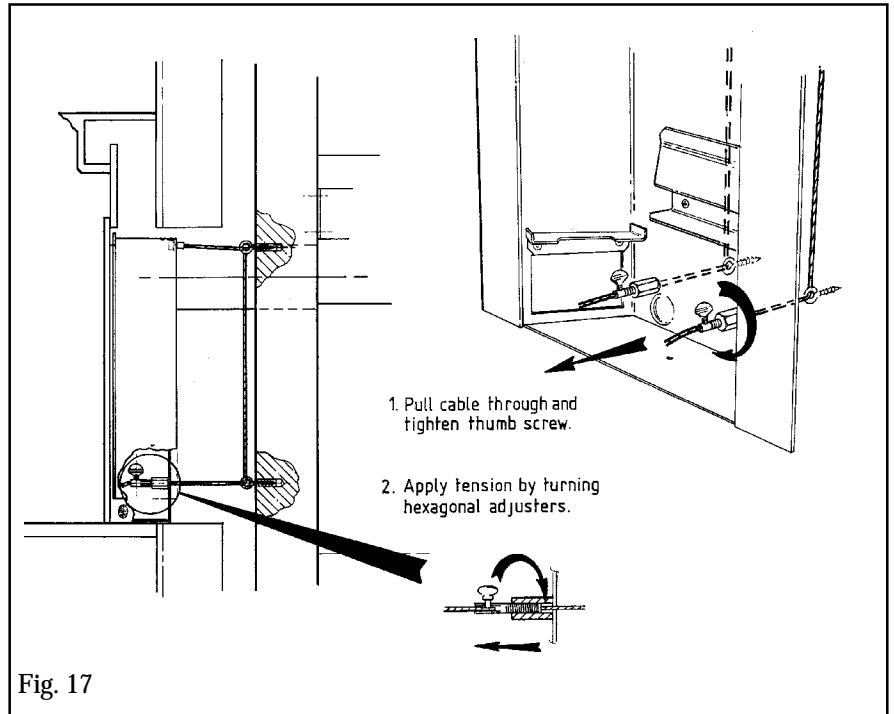

## Fan box installation

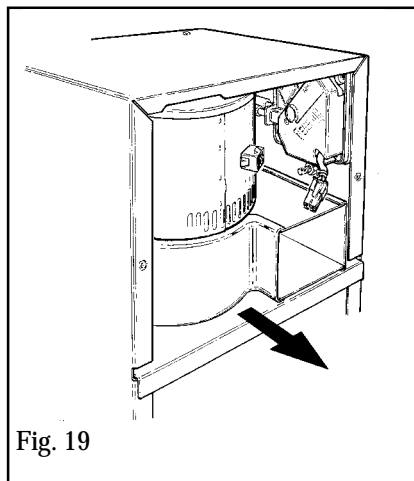

Fig. 19

Before installation can proceed it will be necessary to remove the fan unit from the fan box.

Remove the 2 cover retaining screws and withdraw the fan unit. See figure 19 .

Checking inside for any loose unwanted packaging

For transit purposes the weather shield is supplied as a loose part.

Remove this from the loose parts pack and fit to the fan box as described below.

If the fan box is to be sited totally outside the wall fit the brackets with the short flanges flush with the air intake end of the fan box (see figure 20).

The fan box may be recessed 150mm into the wall. If this is the case, then fit the brackets with the short legs 50mm from the air outlet face of the fan box (see figure 21).

Use a hammer and chisel to cut an aperture of 230mm by 280mm.

Place the fanbox in position with the spigot located in the flue pipe. Ensure the box is firmly located and correctly aligned against the wall, and mark off the four screw fixing positions on the wall.

Remove the fanbox, Drill at the marked positions four holes using a number 10 drill and plug.

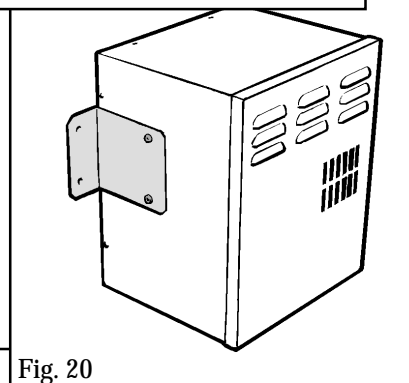

Fig. 20

Locate cable ties and position fan box to the wall. Feed the electrical cable through and secure rubber grommet in access hole of fan box. Carefully draw the loom through the grommet until all excess cable length is contained within the fan compartment. (see fig.22)

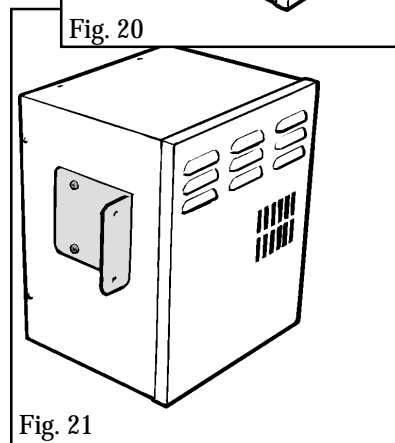

Fig. 21

Replace the fan box to the wall, ensuring that the flue pipe and fan box spigot are fully engaged, and taking care not to snag or otherwise damage the electrical loom. Align and secure the fan box to the wall and fix using the screws supplied. Make good around the fan box, ensuring that no gaps appear between the box and wall.

Stow the excess cable as shown in figure 23. Leave about 200mm of free length for fan motor connection. Secure the stowed cable inside the fan box with cable ties.

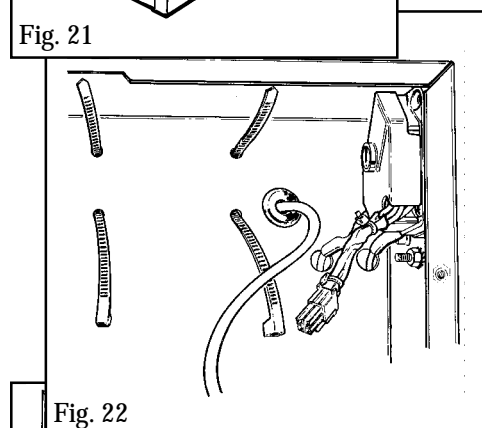

Fig. 22

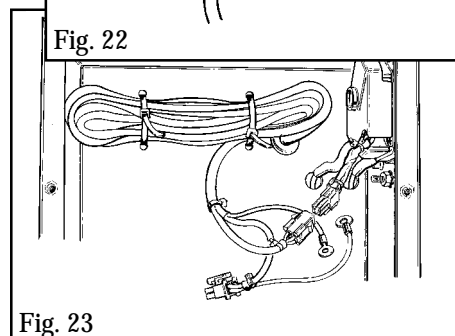

Fig. 23



## Electrical installation

Install a power supply at a switched fuse having a minimum separation of 3mm at all poles. The spur should be readily accessible to the user, easily identifiable and preferably sited adjacent to the appliance. It should only connect this appliance.

**WARNING : Ensure the supply is isolated before proceeding.**

Withdraw the electrical control unit and its heatshield by removing the two fixing screws. See figure 24.

Ensuring continued isolation of mains supply, withdraw end of mains cable through the large rectangular aperture in the firebox. **Note : Under no circumstances should the mains cable provided be removed from the appliance.**

Connect the end of the mains lead to the fused spur. If it is necessary for the mains lead to be routed behind the appliance, then it can be fastened to the lower part of the outer heatshield using two 'p' clips. If this is the case, remember to leave 200mm of slack as with the control loom (see page 14).

With the electrical supply and fan box loom now connected, the enclosure can be replaced as shown in figure 24.

Locate the cable loom earth tags and secure to the fan box earth stud using the M4 nut and shakeproof washer supplied. Connect the cable loom to the pressure switch - see figure 26.

Replace the fan unit taking care not to snag or otherwise damage the electrical fittings. Connect the cable loom to the fan unit. (See figure 52 in section entitled "To remove the pressure switch").

Upon completion of cable installation ensure that the loom and cables do not touch the horizontal surface of the fan casing immediately above the rectangular flue gas outlet. If cables run close or are in contact with this surface they should be held clear using the additional cable ties provided.

Upon completion ensure a neat and tidy installation before replacing the fan box cover .

Replace the fan box cover and weather shield (figure 28) and secure using the two screws provided.

## Refit the burner unit

Replacing the burner unit, is the reverse of removal. See text, "preparing for installation".

In addition the burner loom is to be secured to the burner support bracket using the fixing clip supplied. (See figure 27).

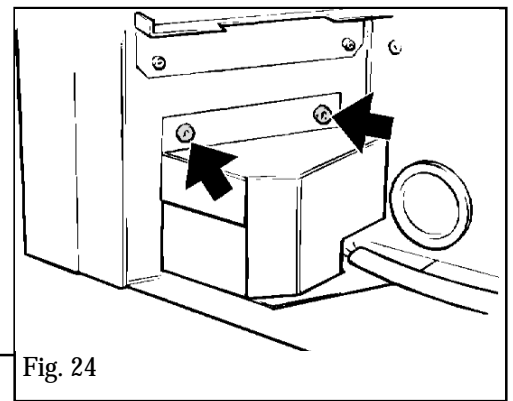

Fig. 24

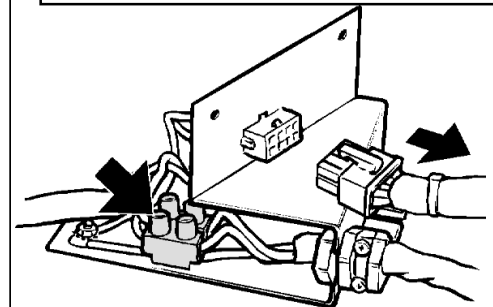

Fig. 25

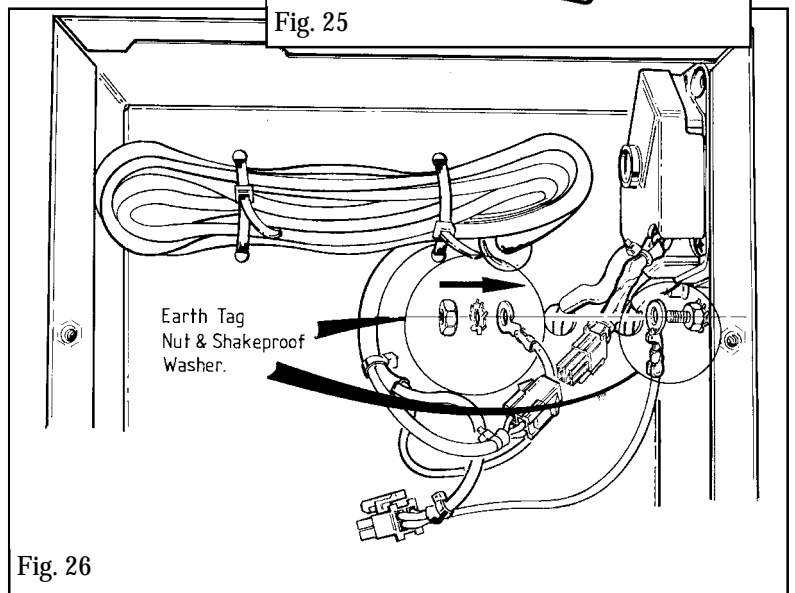

Fig. 26

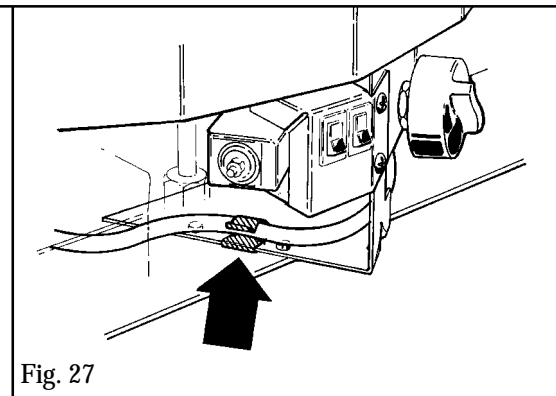

Fig. 27

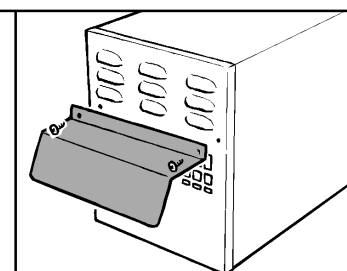

Fig. 28

## Electrical test

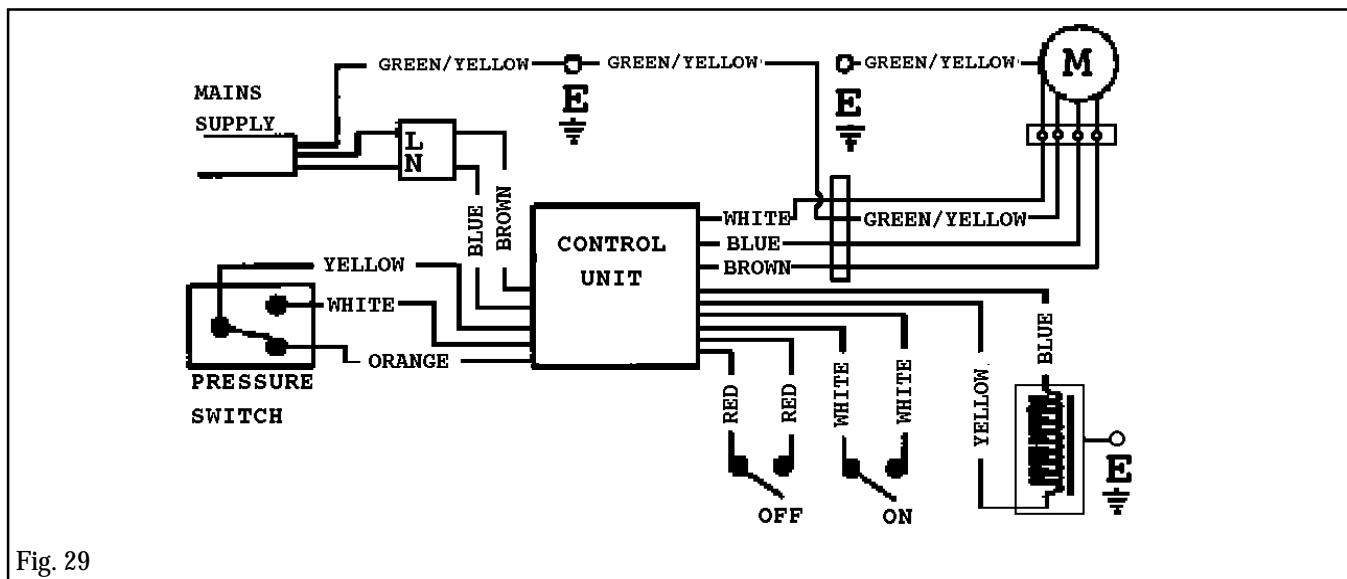

Fig. 29

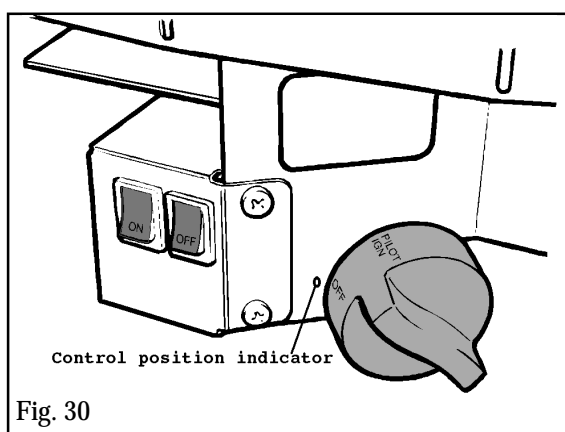

Fig. 30

Switch on power supply to the appliance. The red indicator light at the left side of the burner should be on.

Press and hold in the “on” switch at the front of the burner. Within a few seconds, the Fan motor should start and the indicator light should go out.

Release the “on” switch. The fan should continue to run.

Press the “off” switch. The fan should stop and the indicator light should come on.

The fan has a “boost” speed intended to clear any minor exhaust obstructions. To check its operation:

- i. Switch the fan on.
- ii. Go outside the building and place a hand over the rectangular exhaust outlet of the terminal. The fan should be heard to increase to “boost” speed within approximately two seconds.
- iii. Remove the hand. The fan should revert to normal speed after approximately three seconds.

The unit includes a blocked flue sensor system. To check its operation:

- i. Switch the fan on.
- ii. Block off the rectangular exhaust outlet of the terminal. The system should shut down and the indicator should light within ten seconds.
- iii. After checking remove the flue blockage and turn off the electrical supply to the appliance. If the above tests are not satisfactory, refer to the servicing section of this manual.

### Terminal guarding

Position the terminal guard to wall, align and ensure equal clearances around fan box. Mark off the four fixing positions on wall. Remove the terminal guard and drill at the marked positions, four holes using a no. 10 drill. Insert wall plugs, reposition the terminal guard and secure to wall using four screws supplied.

## PART 7: GAS SUPPLY INSTALLATION

Connect the supply line to the appliance.

Unless the supply pipe connection is from the left front side, the supply pipe will have to be formed to avoid various components below the burner. An installation template is supplied which contains a diagram for bending this supply pipe.

If gas supply is to the rear of the appliance, then entry is via the large grommet, at the lower left hand side of the back face. Pierce the grommet to allow pipe entry. Gas supply can also be accommodated at the lower right hand side of the appliance. This small grommet will require removal or a careful incision for pipe entry. (See figure 31).

Check the installation pipework for gas soundness in accordance with the current edition of BS6891. **Do not use leak detection sprays on this appliance. Sprays may affect the operation of electrical components. Keep all liquid detection fluids clear of electrical components.** A long brush may be required to reach some joints .

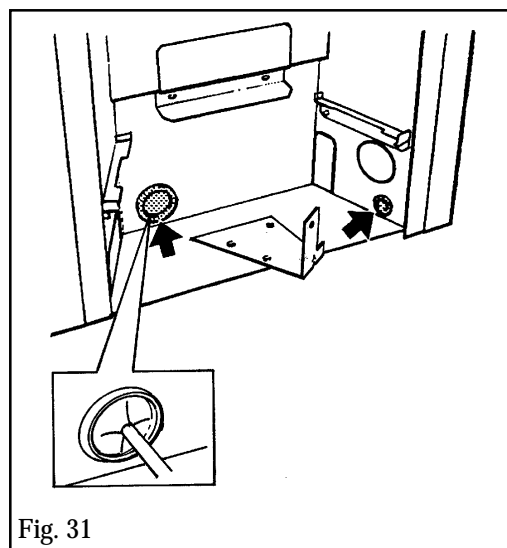

Fig. 31

### Preliminary Burner Checks

Some burner operations can be checked at this stage. Checking now will mean that less disassembly will be required if any problems are found. **A full check should still be made, however, after final installation.**

- Switch on electrical power supply to the appliance. The red indicator light at the left side of the burner should come on.
- If closed, open the isolating valve at the inlet elbow.
- Press and hold in the “on” switch. Within two seconds, the Fan motor will start and the indicator light should go out.
- Release the “on” switch. The fan should continue to run.
- Depress the control knob and turn anticlockwise partially towards the “PILOT/IGN” position until some resistance is felt. Keep depressed at this position to purge air from the system then, while keeping it depressed, turn fully to the “PILOT/IGN” position. A spark should be generated at the pilot while turning. The spark should ignite the pilot.
- When pilot ignition has been achieved, keep the control knob depressed for approximately ten seconds to allow the thermocouple probe to warm up and then release it. If the pilot does not remain alight, ensure that the air has been purged, that the pilot orifice is clear and that the thermocouple connections are sound. Replace the pilot unit if necessary (see servicing section of this manual).
- When the pilot is alight and stable, partially depress the knob and turn to “LOW”. The pilot should then light the main burner at its low setting. There may be a slight delay between the pilot lighting and ignition of the gas at the main burner. This is normal and is due to the time required to fill the main burner compartment with sufficient gas for ignition.
- With the burner at “LOW”, partially depress the control knob and gradually turn it anti-clockwise. The burner flames should gradually increase until the knob reaches the “HIGH” position. **When the above checks have been completed partially depress the control knob and turn to “OFF” position.**
- Press the “off” switch. The fan should stop and the indicator light should come on.
- If the above checks are satisfactory, continue with the installation. If not, check the control and ignition circuitry and components as described in the servicing section of this manual.

## Check Reference Pressure .

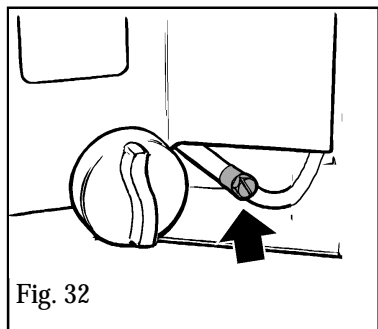

Fig. 32

The appliance is pre-set to give the correct setting pressure as shown in part 1 of this manual. No adjustment is necessary. Check the burner pressure by fitting a pressure gauge at the test point. The test point is on the pipe situated below the bottom right corner of the burner unit (See figure 32). Check the pressure with the fan on, the appliance alight and set at maximum input.

After checking, turn off the appliance. Remove the pressure gauge and replace the test point sealing screw. Relight the appliance. Turn to the maximum input position and test around the sealing screw for gas soundness with a suitable leak detection fluid. **Do not use leak detection sprays on this appliance. Sprays may affect the operation of electrical components. Keep all liquid detection fluids clear of electrical components.**

## PART 8: FITTING THE CERAMICS

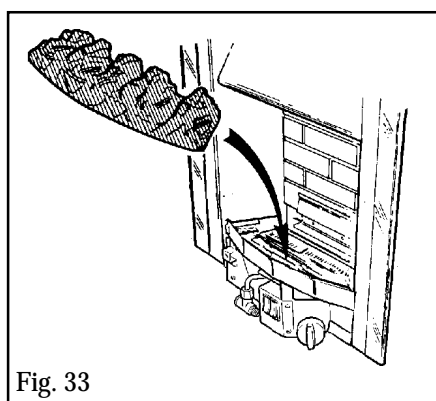

Fig. 33

Place the front base coal in the burner compartment so that it rests on the ledges at the sides and front. Pull the coal forward so that it is immediately behind the front rim of the burner compartment. (See Fig 33 and 34).

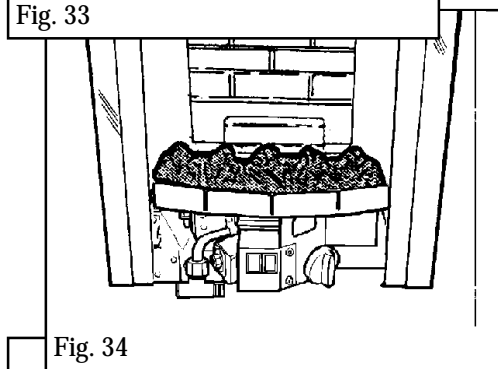

Fig. 34

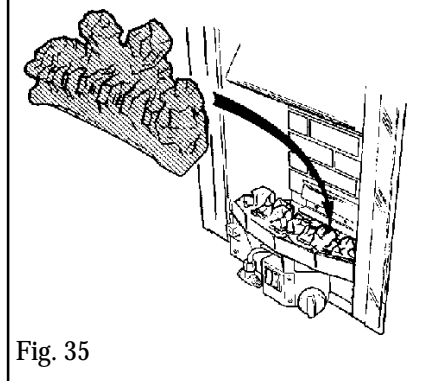

Fig. 35

Place the rear base coal in the burner compartment behind the front coal. It should rest on the ledge at the back of the burner compartment and its rear face should touch the rear ceramic wall (See figure 35 and 36).

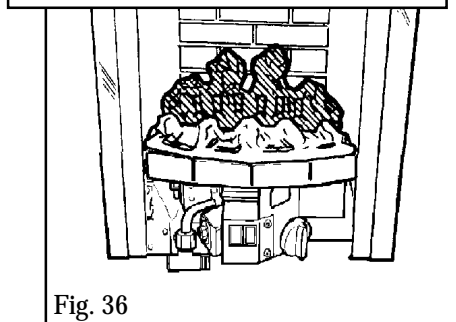

Fig. 36

Install the 9 loose coals as follows. The smooth surfaces of the coals should be at the bottom and back. Select the two smallest coals and put them aside until all the other coals are installed. Place four of the medium size coals in the four valleys of the front coal. Place the left side coal so that the customer will be able to see the pilot flame. See figures 37 and 38.

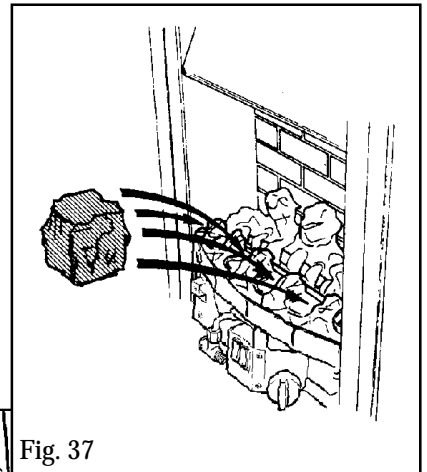

Fig. 37

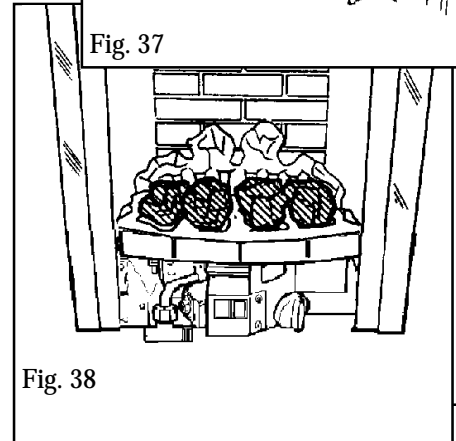

Fig. 38

Place the three remaining medium size coals behind and approximately midway between each of the coals in the front row. See figures 39 and 40.

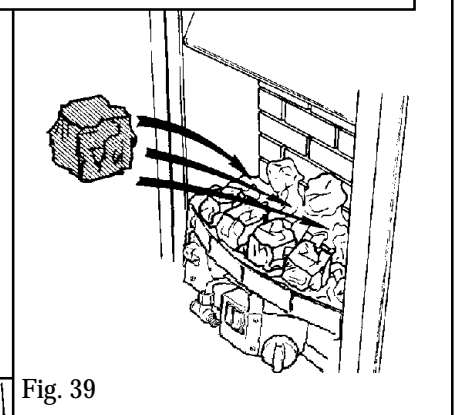

Fig. 39

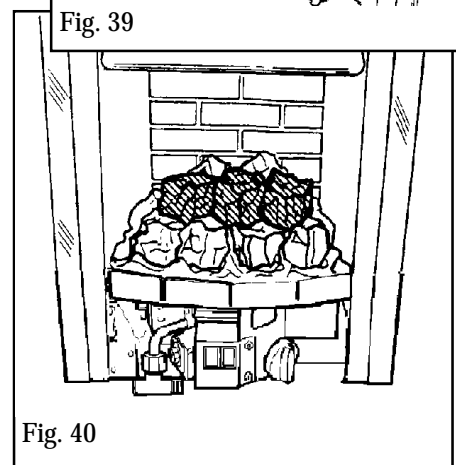

Fig. 40

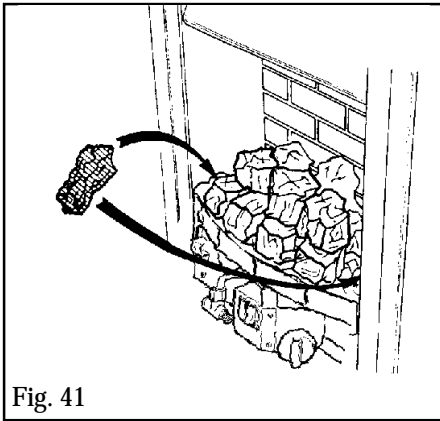

Fig. 41

Place the two remaining small coals alongside the main coals as per figures 41 and 42.

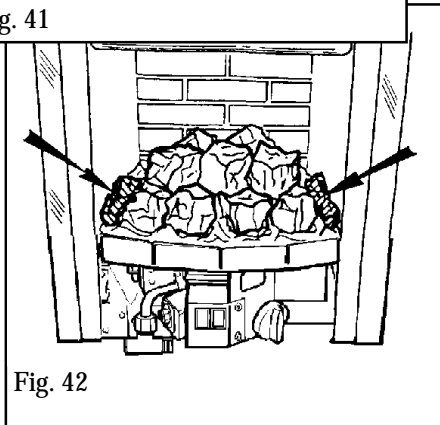

Fig. 42

## PART 9: CHECKS

### Recheck Control Settings

Now that all the ceramic fuel effects are in position, the control operation must be fully rechecked.

- Make sure that the isolating valve at the inlet elbow is open and that the electrical power supply is on (the indicator light should glow).
- Press and hold in the “on” switch. Within two seconds, the Fan should start and the indicator light should go out.
- Release the “on” switch. The fan should continue to run.
- Depress the control knob and turn anticlockwise partially towards the “PILOT/IGN” position until some resistance is felt. Keep depressed at this position to purge air from the system then, while keeping it depressed, turn fully to the “PILOT/IGN” position. A spark should be generated at the pilot while turning. The spark should ignite the pilot. Check that the pilot flame is visible.
- When pilot ignition has been achieved, keep the control knob depressed for approximately ten seconds to allow the thermocouple probe to warm up and then release it. If the pilot does not remain alight, ensure that the pilot orifice is clear.
- When the pilot is alight and stable, partially depress the knob and turn to “LOW”. The pilot should then light the main burner at its low setting. There may be a delay of up to four seconds between the pilot lighting and ignition of the gas at the main burner. This is normal and is due to the time required to fill the main burner compartment with sufficient gas for ignition.
- When the burner is lit, partially depress the knob and gradually turn it anticlockwise. The burner flames should gradually increase until the knob reaches the “HIGH” position.
- Partially depress the control knob and turn back to “PILOT/IGN”. The main burner flames should be extinguished but the pilot should remain alight.
- Partially depress the control knob and turn to “OFF”. The pilot should be extinguished.
- Press the “off” switch to turn off the fan (the indicator light should glow).

## Check for spillage

***A spillage check must be made before leaving the installed appliance with the customer. Make this check with the appliance fully installed with the ceramic fuel effects and front surround in position.***

- Close all doors and windows in the room containing the appliance.
- Turn on the fan. Light the appliance and turn the control knob to “HIGH”.
- Leave the appliance on for five minutes.
- Place the smoke match tube into the burner box below the hood (see figure 43).
- The installation is satisfactory if the smoke is drawn into the appliance. If the smoke is not drawn into the appliance the fan powered extraction system is not operating correctly. ***Do not allow the appliance to be used until the fault is corrected.***
- If the above test is satisfactory, open all internal connecting doors, hatches, etc. in the room. Keep all doors and windows that open to the outside of the building closed. Recheck for spillage as above. If an extractor fan or other air circulating system is installed in the same room as the appliance or a connecting room, check that spillage does not occur with the fan operating and all doors and other openings between the fan and the appliance open.
- If the smoke is drawn into the appliance, continue with the installation. If the test is not satisfactory, ***Disconnect the appliance and seek expert advice***
- If any other non-sealed gas appliances are installed in connecting rooms, check to ensure that there is no spillage from these appliances when Model 527 \ 528 is operating with its fan on. Check these other appliances by the procedure supplied by the manufacturer.

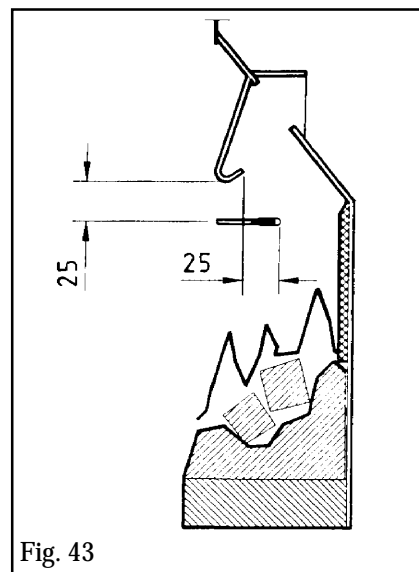

## Flame supervision & spillage monitoring system

The pilot unit incorporates a system which will automatically shut off the gas supply if the pilot flame goes out or if there is insufficient oxygen due to spillage or lack of ventilation.

Check that the system operates properly as follows;

- Turn on the fan. Light the appliance and turn the control knob to “HIGH”. Leave for one minute.
- Turn back to “OFF” to extinguish the pilot. ***Note the time when the pilot goes out.*** Listen for a snap sound at the gas tap. ***Note the time when the sound is heard.*** This sound is caused by an electromagnetic valve shutting off the gas supply through the tap. The valve is located in the body of the tap. The valve should operate ***within 60 seconds of the pilot going out.*** If the valve does not operate within this time limit do not allow the appliance to be used until the fault has been corrected.

***The spillage monitoring system must not be adjusted, bypassed or put out of operation. This monitoring system, or any of its parts, must only be exchanged using Valor Authorised parts.***

## PART 10: FRONT CASTING ASSEMBLY & FINAL REVIEW

### Front casting assembly for model 527 (See fig. 44)

- Remove the nut from the threaded stud on the brass finials
- Locate the brass bar in the slots at the top of the front casting.
- Insert the threaded studs through the holes at the top of the casting to trap the brass bar in position
- Fit the nuts to the studs underneath the casting and tighten.
- Place the front casting unit between the sides of the front surround and place the bottom front casting underneath.

#### Final review

- Hand these instructions and the owner's guide and the smoke match tube to the customer.
- Visually inspect the appliance. Clean off any marks incurred during installation.
- Advise the customer how to operate the appliance.
- Explain to the customer that the appliance has a flame failure & spillage monitoring system. Point out the explanation of this system shown in the owner's guide under "Operating the Fire. Advise that if the fire goes out for any reason, wait at least three minutes before relighting.
- Stress that if the monitoring system repeatedly shuts off the fire, the appliance should be switched off and a specialist should be consulted.
- Advise the customer that the castings, front surround, firebox and ceramic pieces can be cleaned as described in the user's instructions and that the coal pieces must be replaced as described in those instructions.
- ***Stress that no extra coals must be added over and above those supplied with the appliance and that any replacements must only be the authorised spares. Warn that ignoring this advice could cause incomplete clearance of the products of combustion with consequent health hazards.***
- Recommend that the appliance should be serviced by a competent person at least annually.

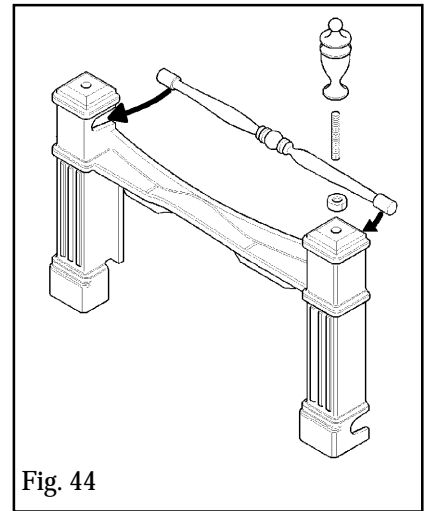



## PART 11: SERVICING PARTS AND REPLACEMENT

- **Always turn off the gas and isolate the electric supply before commencing any servicing and make sure that the appliance is cold. (The inlet elbow for this appliance incorporates an isolating valve).**
- Check that the appliance is clean and that soot or debris is not blocking the gaps between the coals causing an imperfect flame.
- Check that soot or debris is not impairing the electrode spark or pilot burner.
- Check that soot or debris is not blocking any of the slots in the main burner.
- Remove any lint from the components
- After servicing, make sure that the ceramic fireback and coals are replaced correctly as described in the installation instructions.
- **Always test for gas soundness and spillage after servicing the appliance and check operation of all controls. (Do not use leak detection sprays on this appliance. Sprays may affect the operation of electrical components. Keep all liquid detection fluids clear of electrical components.)**

### To replace the burner plaques

- Remove the 9 loose coals, front base coal, rear base coal and ceramic back wall. The plaques can be then be removed as follows without removing the front surround or front casting.
- Remove the plaques clamping strips by detaching 6 screws shown in figure 45.
- Remove the plaques, centre gasket and bottom gasket.
- Fit a new bottom gasket.
- Place the new left hand plaque in position. The left side of the plaque must touch the inside edge of the retaining flange at the left side of the burner well.
- Place the new right hand plaque in position. Fit a new centre gasket between the plaques. If there is any play between the plaques and the end retaining flanges, push the plaques and gasket firmly to the left squeezing the gasket between the two plaques. Any gap should be between the right side of the plaque and the right side retaining flange.
- Fit the front and rear plaque clamping strips. Make sure that the plaques are as far to the left as possible. **It is important that the left side plaque is accurately positioned so that it has the correct relationship to the pilot.** Fully tighten the clamping strips.
- Refit the ceramic fuel effects as described in part 8 of this manual.

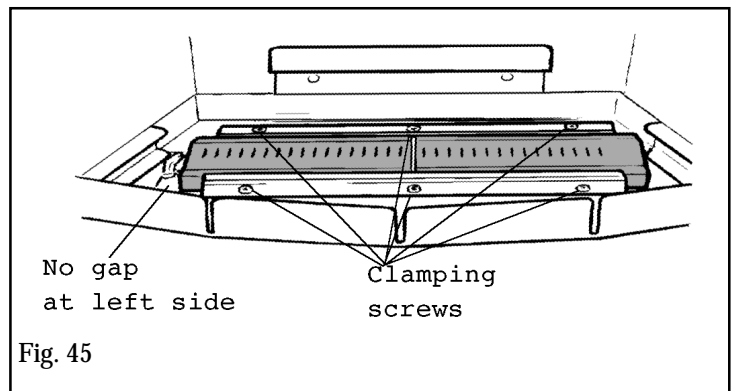

### To Remove The Pilot Unit

- Remove the 9 loose coals, front base coal, rear base coal and ceramic back wall.
- Remove the front cover castings.
- Support the inlet isolating elbow to avoid straining the pipework and disconnect the appliance from the elbow.
- Detach the burner unit from the fire box (see following section) Carefully lift the burner unit forward making sure that the unit does not snag on any leads. Rest the burner on its front face to allow access to the pilot and gas tap.
- Disconnect the electrode lead from tab underneath the electrode.
- Undo the thermocouple nut at the gas tap.
- Disconnect the pilot pipe from the pilot unit elbow.
- Detach the pilot unit from the burner unit by removing two screws (see figure 46). Lift the pilot unit clear.
- Refit in the reverse order. Make sure no leads are trapped.

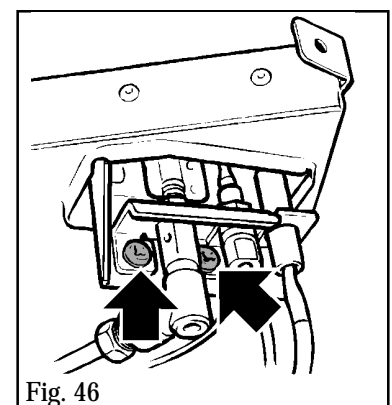

## To Completely Remove The Burner Unit

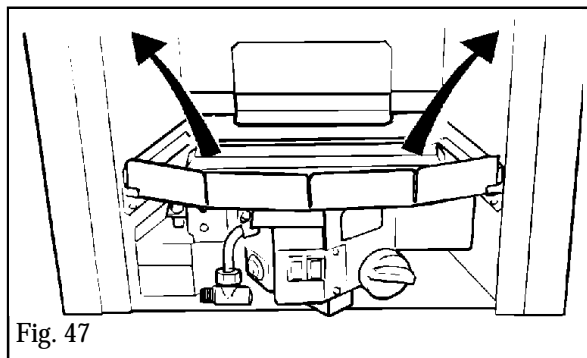

- Remove the ceramics, remove the front cover castings, disconnect the appliance at the isolating valve, and detach the burner unit from the fire box.
- Detach the burner wiring loom connection at the right side of the burner (see figure 48).
- Refit in the reverse order. Make sure no leads are trapped.

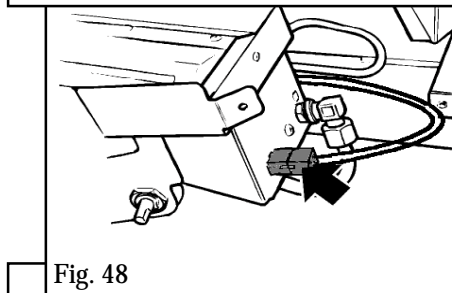

## To Remove The Gas Tap/F.S.D & Solenoid Assembly.

- Remove the burner unit as described above.
  - Disconnect the electrode lead from tab underneath the electrode.
  - Undo the thermocouple nut at the gas tap.
  - Disconnect the inlet pipe at the solenoid junction.
  - Disconnect the main burner pipe at the tap end.
  - To gain access to the pilot pipe connection, detach the fan switch bracket from the burner control bracket by removing two screws (see figure 49).
  - Disconnect the pilot pipe at the tap end.
  - Pull off the control knob.
  - Remove the gas tap fixing nut.
  - Disconnect the two burner wiring loom leads from the solenoid unit.
  - Disconnect the earth lead from the solenoid unit.
  - Pull the tap & solenoid unit clear.
  - To separate the tap from the solenoid, detach the solenoid unit at the gas tap end
- Replace in the reverse order.

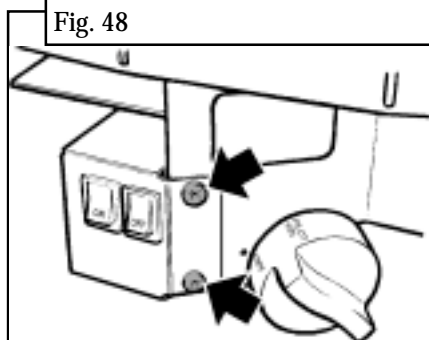

## To Remove The Piezo Generator

- Remove the gas tap, FSD & solenoid unit as described above.
- Make sure that the tap is in the off position.
- Remove the circlip holding the piezo unit to the tap.
- Remove the piezo unit.
- Replace in the reverse order.

## To Remove The Main Burner Elbow Injector

- Detach the burner unit from the fire box as described above.
- Disconnect the main burner pipe from the elbow injector. If necessary, loosen the pipe at the gas tap end to swing the pipe clear of the injector.
- Unscrew the elbow injector from the support bracket.
- Refit in the reverse order. Make sure that no leads are trapped.

## To Remove an “On” or “Off” Switch

- Detach the fan switch bracket from the burner control bracket by removing two screws (see figure 49). Carefully pull clear of the burner unit.
- Detach the two leads from the switch which is to be removed.
- Press in the plastic spring grips at the ends of the switch and pull the switch clear of the bracket.
- Replace in the reverse order. Make sure the correct leads go to each switch (see wiring diagram figure 29). Make sure that no leads are trapped.

## To Gain Access to the Electrical Control Components

- Remove the burner unit as described above.
- Detach the control unit from the fire box (left hand side) flange by removing two screws (see figure 50). Carefully withdraw the unit.
- Detach the fan wiring loom connection. (see figure 51).
- The control unit can be pulled forward as far as the slack in the mains lead will allow. **Do not stress the mains lead.**
- When replacing the unit make sure that all the leads are correctly and firmly connected (see wiring diagram figure 29), and that no leads are trapped.

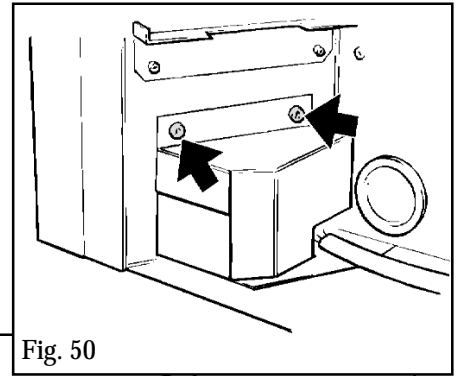

Fig. 50

## To Remove the Distribution block

- See section “To Gain Access to the Electrical Control Components” above .
- Remove the two screws fixing the block to the control bracket.
- Disconnect the earth lead from the control bracket.
- Disconnect the two leads (Brown & blue) from the mains cable connection block. (See figure 51)
- Replace in the reverse order. Make sure that all the leads are correctly and firmly connected (see wiring diagram figure 29) and that no leads are trapped.

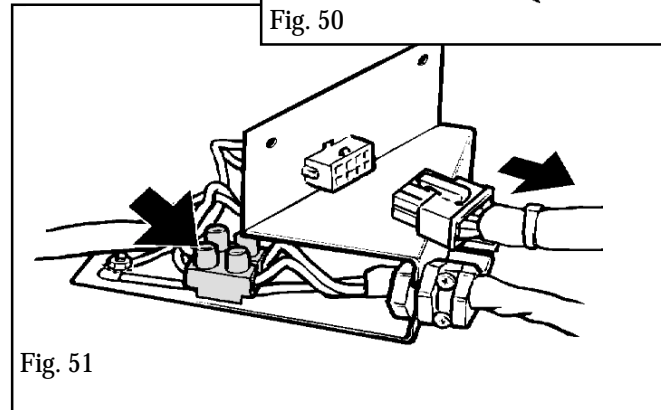

Fig. 51

## To Remove the Fan

- Remove the terminal guard basket, and then the weather shield and front plate of the fan box (2 screws).
- Disconnect the wiring loom connector at the fan motor casing.
- Withdraw the fan unit from the fan box taking care not to snag or damage the wiring loom. (See figure 52).
- Replace in reverse order.

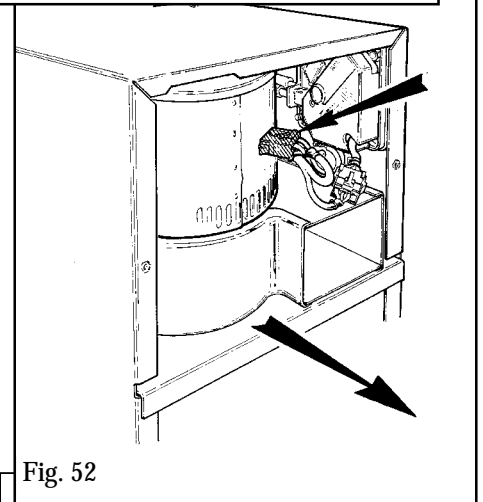

Fig. 52

## To remove the pressure switch

- Access to the pressure switch is gained by first removing the fan. (See preceding text - fan removal procedure).
- Disconnect the wiring loom to pressure switch connector.
- Remove the two pressure switch fixing screws, and carefully prise free the two rubber sensing tubes whilst withdrawing the pressure switch from the fan box. *Note : Ensure that the tube ends secured to the metal sensing pipes at the back of the box are not disturbed.* Refer to figures 22 & 23 in section “Fan box installation”.
- Replace in reverse order.  
When replacing...
  1. Ensure that the vacuum tubes are connected to the correct sensing points. The positive sensing point (⊕ marked on the switch) runs to the metal sensing pipe positioned nearest to the side of the fan box. *Note :* When fitted correctly, both leads will run neatly, but if incorrectly fitted, they will twist across each other.
  2. Ensure the electrical connector is correctly and firmly connected.

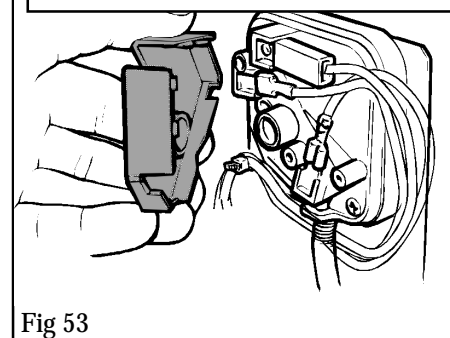
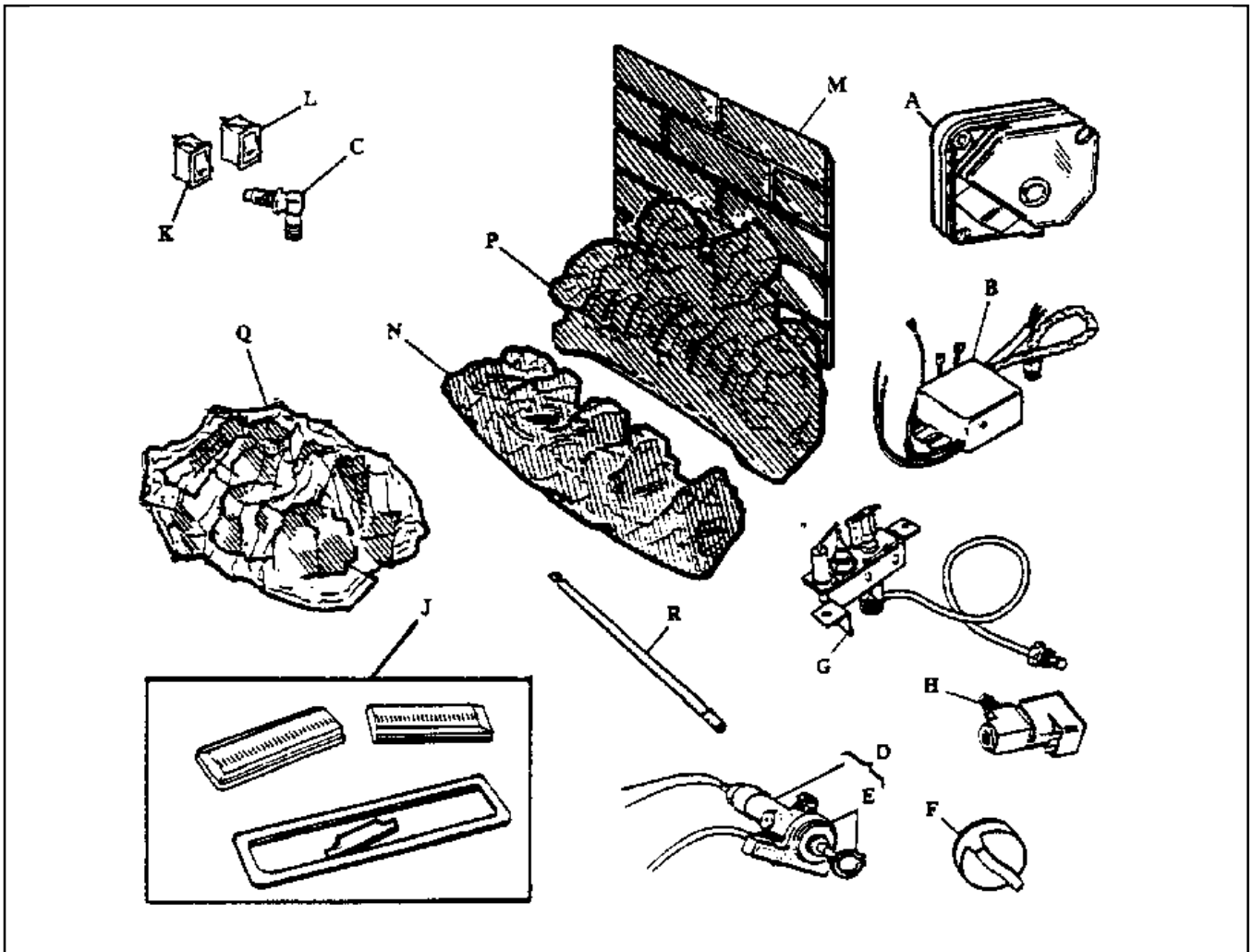

Fig 53

## Pressure switch strip down

- Remove the cover from the pressure switch to gain access. (See figure 53).
- Disconnect the three leads, yellow, orange and white.
- Replace in reverse order. Ensure that all three leads are firmly connected

## Short List Of Spares



Key No.	Description	No. off	Part No.
A	Air pressure switch	1	567359
B	Electrical control unit	1	567369
C	Injector (Elbow type) Bray cat 82 size 360	1	545959
D	Gas tap & spark generator	1	545969
E	Spark generator	1	521069
F	Control knob	1	545979
G	Pilot unit	1	545949
H	Solenoid valve	1	559719
J	Burner plaque & gasket set	1	545989
K	"On" switch	1	559729
L	"Off" switch	1	559739
M	Ceramic rear wall	1	545999
N	Front coal	1	566389
P	Rear base coal	1	566399
Q	Pack of loose coals	1	566409
R	Smoke match tube	1	541169

### **Safety First.**

Valor fires are CE Approved and designed to meet the appropriate British Standards and Safety Marks.



### **Quality and Excellence.**

#### **At the heart of every Valor fire.**

All Valor fires are manufactured to the highest standards of quality and excellence and are manufactured under a BS EN ISO 9001 quality system accepted by the British Standards Institute.



### **The Highest Standards**

Valor is a member of the Society of British Gas Industries which works to ensure high standards of safety, quality and performance.



### **Careful Installation**

Valor is a Corgi registered company. All our gas fires must be installed by a competent Installer in accordance with our Installer Guide and should not be fitted directly on to a carpet or floor of combustible material.

Valor Heating, Erdington, Birmingham B24 9QP

Because our policy is one of constant development and improvement, details may vary slightly from those given in this publication