

# climaVAIR

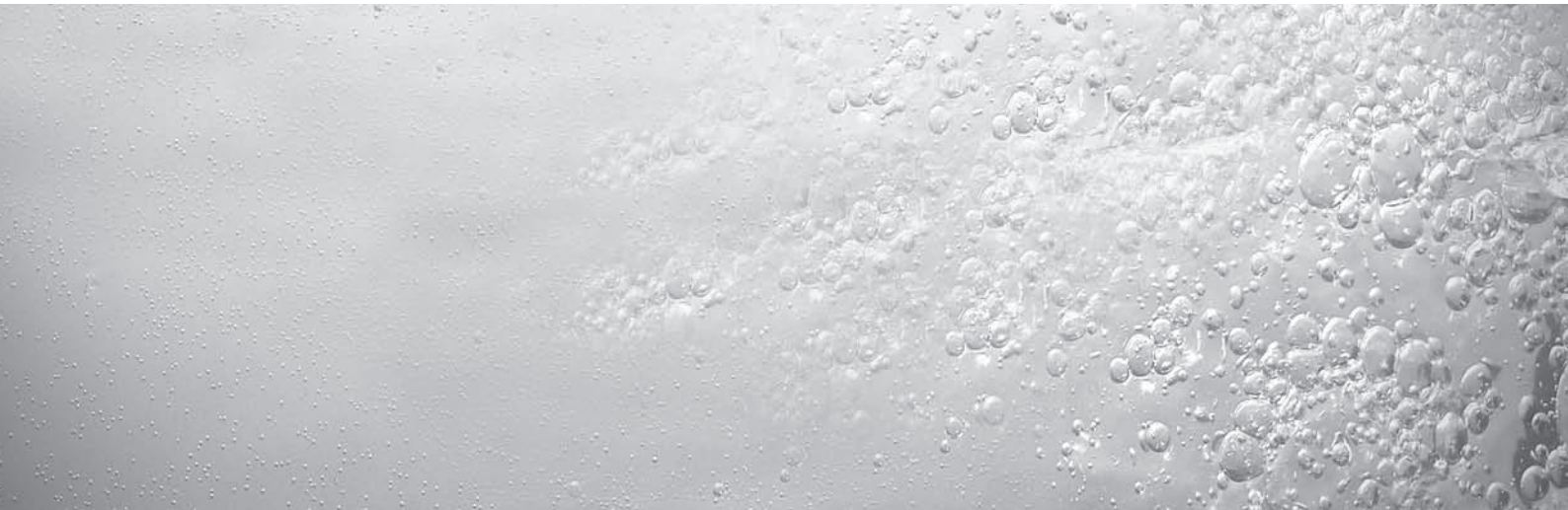

VA 6-060 MXNHO  
VA 6-085 MXNHO  
VA 6-105 MXNHO

VA 6-020 MXNHI  
VA 6-025 MXNHI  
VA 6-035 MXNHI  
VA 10-020 MXNHI  
VA 10-025 MXNHI  
VA 10-035 MXNHI  
VA 6-035 MXNHKI  
VA 6-050 MXNHKI  
VA 6-035 MXNHDI  
VA 6-050 MXNHDI

For the fitter

Installation Manual

# Air-conditioner - climaVAIR

Multi Split Type

VA 6-060 MXNHO  
VA 6-085 MXNHO  
VA 6-105 MXNHO

VA 6-020 MXNHI  
VA 6-025 MXNHI  
VA 6-035 MXNHI  
VA 10-020 MXNHI  
VA 10-025 MXNHI  
VA 10-035 MXNHI  
VA 6-035 MXNHKI  
VA 6-050 MXNHKI  
VA 6-035 MXNHDI  
VA 6-050 MXNHDI

# Contents

## Contents

<b>1</b>	<b>Your Safety</b> .....	<b>3</b>	10.5	Installation of the Coolant Pipes .....	18
1.1	Symbols used .....	3	10.5.1	Handling the Coolant Pipes .....	18
1.2	Proper Use of the Unit .....	3	10.5.2	Laying of the Coolant Pipes .....	18
<b>2</b>	<b>Extreme Operating Conditions</b> .....	<b>3</b>	10.6	Installation of the Fresh Air and Bypass Lines ..	19
<b>3</b>	<b>Identification of the Unit</b> .....	<b>3</b>	10.7	Indoor unit Assembly in the Ceiling .....	19
<b>4</b>	<b>Declaration of Conformity</b> .....	<b>4</b>	10.8	Connections .....	20
<b>5</b>	<b>Description of the Unit</b> .....	<b>4</b>	10.9	Installation of the decorative panel .....	20
5.1	Wall mounted type Indoor Unit .....	4	<b>11</b>	<b>Installation of the Duct Indoor Unit</b> .....	<b>21</b>
5.2	Cassette type Indoor Unit .....	5	11.1	Initial check .....	21
5.3	Duct type Indoor Unit .....	5	11.2	Attachment of the indoor unit .....	21
5.4	Outdoor Unit .....	6	11.3	Installation of the indoor unit .....	21
5.5	Remote Controller .....	7	11.4	Installation of the drainage pipe .....	21
5.6	Connections and Channels .....	7	11.5	Hanging the indoor unit .....	21
5.7	Wall mounted type unit Accessories .....	7	<b>12</b>	<b>Installation of the Outdoor Unit</b> .....	<b>22</b>
5.8	Cassette type unit Accessories .....	7	12.1	Selecting the Assembly Location .....	22
5.9	Duct type unit Accessories .....	7	12.2	Planning the Coolant Return .....	23
5.10	Technical Specifications .....	8	12.3	Connection of the Coolant Pipes .....	23
<b>6</b>	<b>Transport</b> .....	<b>9</b>	12.4	Connection of the Pipe for the Drainage of the Condensed Water .....	23
<b>7</b>	<b>Unpacking</b> .....	<b>9</b>	<b>13</b>	<b>Electric Wiring</b> .....	<b>24</b>
<b>8</b>	<b>Installation</b> .....	<b>9</b>	13.1	Safety Precautions .....	24
8.1	Qualification of the Installation Personnel .....	9	13.2	Remark with regard to Directive 89/336/EEC .....	24
8.2	General precautions to be taken into account before starting the installation .....	9	13.3	Electric Connection of the Indoor Unit .....	25
8.3	General Installation Diagram with Wall mounted type units .....	10	13.4	Electric Characteristics .....	27
8.4	General Installation Diagram with Cassette type units .....	10	<b>14</b>	<b>Communication between the Indoor and Outdoor Units</b> .....	<b>28</b>
8.5	General Installation Diagram with Duct Type units .....	11	14.1	Address setting for Cassette and V6 Wall Indoors by using the remote .....	28
<b>9</b>	<b>Installation of the Wall mounted Indoor Unit</b> .....	<b>12</b>	14.2	Address setting for Cassette and Duct Indoor units by using Dip switches .....	29
9.1	Selecting the Assembly Location .....	12	14.3	Address setting for Wall units when using the dip switches .....	29
9.2	Fixing the Assembly Plate .....	12	14.4	Address setting for Wall Indoors V 10 by using the remote and the LCD display board .....	30
9.3	Installation of the Pipes .....	12	<b>15</b>	<b>Preparation for Use</b> .....	<b>31</b>
9.3.1	Methods for the Correct Discharge of the Condensed Water .....	12	15.1	Checking for Leaks .....	31
9.3.2	Handling the Coolant Pipes .....	13	15.2	Purging the Installation .....	31
9.3.3	Handling the Condensed Water Pipe .....	13	15.3	Start Up .....	32
9.3.4	Making Holes for the Pipes .....	14	15.4	Troubleshooting .....	32
9.3.5	Laying the Pipes .....	15	<b>16</b>	<b>Error Codes</b> .....	<b>33</b>
9.3.6	Installation of the Indoor Unit Body .....	15	16.1	Cassette .....	33
<b>10</b>	<b>Installation of the Cassette Indoor Unit</b> .....	<b>16</b>	16.2	Duct .....	34
10.1	General Warnings .....	16	16.3	Wall .....	36
10.2	Selecting the Assembly Location .....	16	16.4	Outdoor .....	37
10.3	Recommended Installation Process .....	17			
10.4	Installation of the Condensed Water Pipe .....	17			
10.4.1	Handling the Condensed Water Pipe .....	17			
10.4.2	Laying of the Condensed Water Pipe .....	17			

## 1 Your Safety

### 1.1 Symbols used



**Danger!**  
 Direct danger for life and health.



**Danger!**  
 Danger of electric shock.



**Warning!**  
 Potentially dangerous situation for the product and the environment.



**Note!**  
 Useful information and indications.

### 1.2 Proper Use of the Unit

This unit has been designed and manufactured for acclimatisation purposes by means of air conditioning. The use thereof for other domestic or industrial purposes shall be the exclusive responsibility of the persons projecting, installing or using them in that way.

Prior to handling, installing, start up, using or performing maintenance on the unit, the persons assigned to perform these tasks should be familiar with all the instructions and recommendations set forth in the unit's installation manual.



**Note!**  
 Keep the manuals throughout the service life of the unit.



**Note!**  
 The information relating to this unit is divided between two manuals: installation manual and user manual.



**Note!**  
 This equipment contains R-410A refrigerant. Do not vent R-410A into atmosphere: R-410A, is a fluorinated greenhouse gas, covered by Kyoto Protocol, with a Global Warming Potential (GWP) = 1975.



**Note!**  
 The refrigerant fluid contained in this equipment must be properly recovered for recycling, reclamation or destruction before the final disposal of the equipment.



**Note!**  
 The relevant personnel performing any service of maintenance operations involving the handling of the refrigerant fluid must have the necessary certification to comply with all local and international regulations.

## 2 Extreme Operating Conditions

This unit has been designed to operate within the range of temperatures indicated on Figure 2.1. Ensure that these ranges are not exceeded.

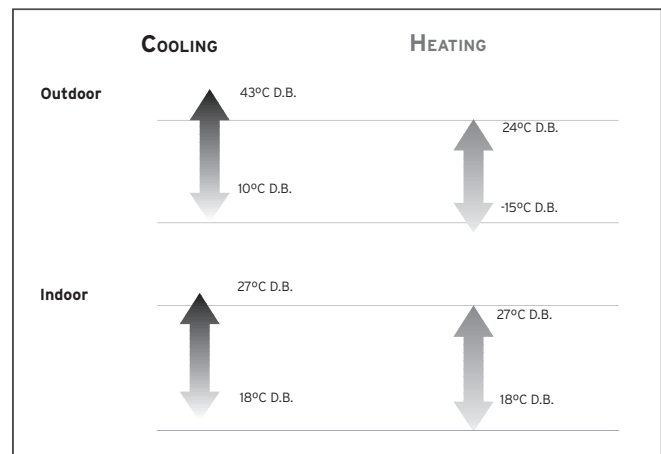

**Fig. 2.1** Operating ranges of the unit.

### Legend

D.B. Temperature measured by dry bulb

## 3 Identification of the Unit

This manual is valid for the Split system series. In order to know the specific model of your unit please refer to the unit nameplates.

The nameplates are located on the outdoor and indoor units.

## 4 Declaration of Conformity

## 5 Description of the Unit

### 4 Declaration of Conformity

The manufacturer declares that this unit has been designed and constructed in compliance with the standard in force with regard to obtaining the CE Marking.

### 5 Description of the Unit

This unit is comprised of the following elements:

- Indoor unit.
- Outdoor unit.
- Remote controller and holder.
- Connections and channels.
- Accessories.

Figure 5.1 shows the unit components.

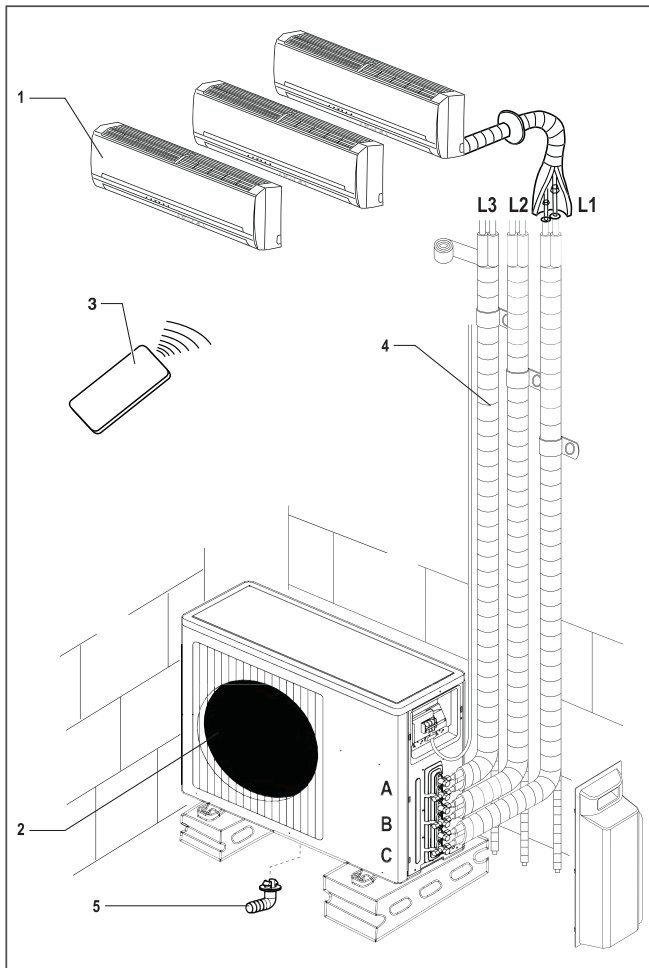

**Fig. 5.1** Unit components.

#### Legend

- 1 Indoor Unit
- 2 Outdoor Unit
- 3 Remote controller and holder
- 4 Connections and channels
- 5 Condensed water drainage pipe

### 5.1 Wall mounted type Indoor Unit

The indoor unit provides acclimatised air inside the room to be acclimatised.

The dimensions and weights of the indoor unit are shown on Figure 5.2 and Table 5.1, depending on the model (please consult the model nameplate). The dimensions are given in mm.

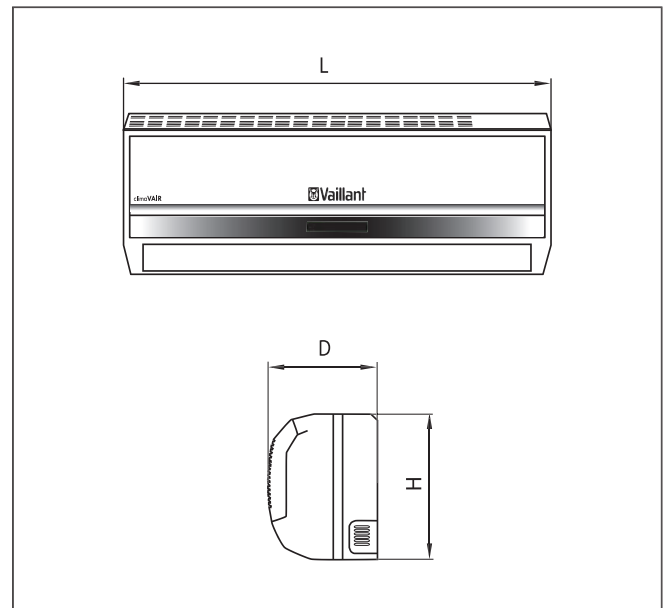

**Fig. 5.2** Dimensions of the indoor unit.

#### Legend

- H Height
- L Width
- D Depth

MODEL	H	L	D	kg
VA 6-020 MXNHI	285	760	182	8.6
VA 6-025 MXNHI	285	760	182	8.6
VA 6-035 MXNHI	285	760	182	8.6
VA 10-020 MXNHI	265	795	197	7.6
VA 10-025 MXNHI	265	795	197	7.6
VA 10-035 MXNHI	265	795	197	7.6

**Table 5.1** Dimensions and weights of the indoor unit.

### 5.2 Cassette type Indoor Unit

The indoor unit provides acclimatised air inside the room to be acclimatised.

The dimensions and weights of the indoor unit are shown on Figure 5.3 and 5.4 and Table 5.2 and 5.3, depending on the model (please consult the model nameplate).

The dimensions are given in mm.

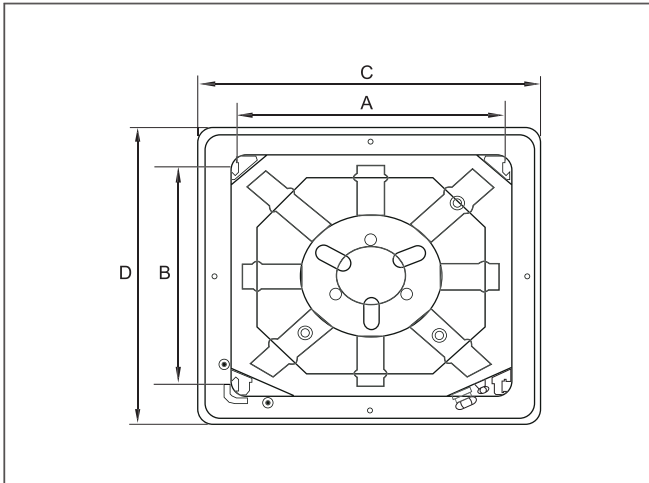

Fig. 5.3 Dimensions of the Indoor Unit (plant).

MODEL	A	B	C	D	Kg
VA 6-035 MXNHKI	570	570	700	700	17
VA 6-050 MXNHKI	580	580	700	700	19

Table 5.2 Dimensions and Weights of the Indoor Unit (plant).

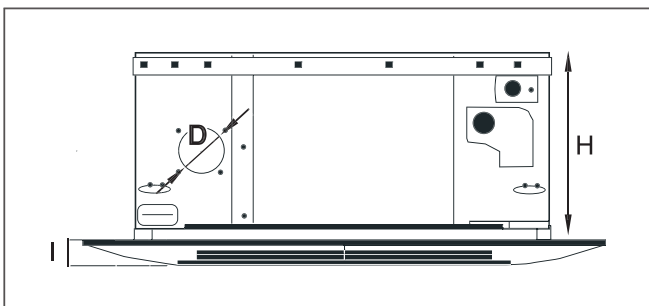

Fig. 5.4 Dimensions of the Indoor Unit (lateral).

MODEL	H	I	ØD
VA 6-035 MXNHKI	260	60	100mm
VA 6-050 MXNHKI	260	60	100mm

Table 5.3 Dimensions of the Indoor Unit (lateral).

### 5.3 Duct type Indoor Unit

The indoor unit provides acclimatised air inside the room to be acclimatised.

The dimensions and weights of the indoor unit are shown on Figure 5.5 and Table 5.4, depending on the model (please consult the model nameplate).

The dimensions are given in mm.

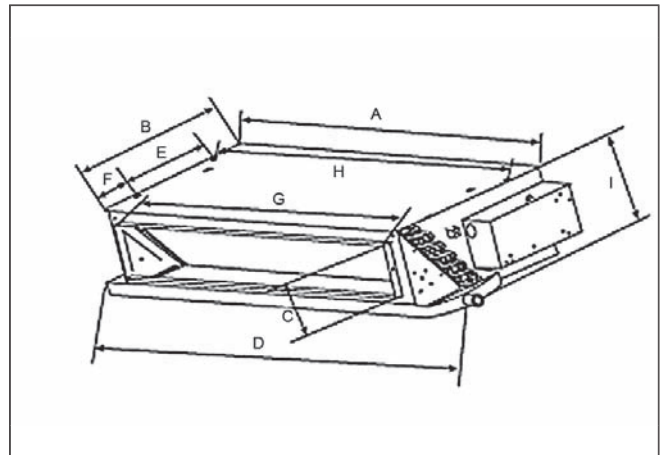

Fig. 5.5 Dimensions of the Indoor Unit.

MODEL	A	B	C	D	E	F	G	H	I
VA 6-035 MXNHDI	538	483.5	131	610	255	105	418	508	220
VA 6-050 MXNHDI	1002	483.5	131	1105	255	105	880	970	220

Table 5.4 Dimensions and Weights of the Indoor Unit.

## 5 Description of the Unit

### 5.4 Outdoor Unit

The outdoor unit ensures that the absorbed air is released to the outside from the room during operation in cooling mode and that the heat introduced into the room during operation in heat pump mode is taken from the outside.

The dimensions and weights of the outdoor unit are shown on Figure 5.6 and Table 5.5, depending on the model (please consult the model nameplate). The dimensions are given in mm.

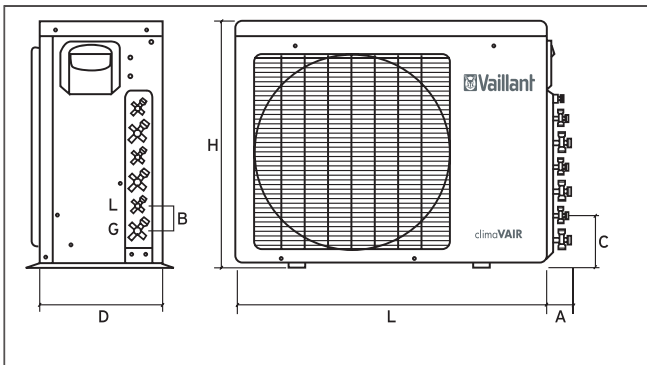

**Fig. 5.6 Dimensions of the outdoor unit.**

#### Legend

- H Height
- L Length
- D Depth
- A Length of valves
- B Distance between valves
- C Distance from the second valve to the floor

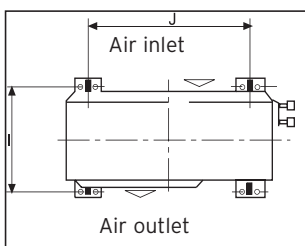

MODEL	H	L	D	A	B	C	I	J	Kg
VA 6-060 MXNHO	680	928	288	54	51	147	319,5	583	54
VA 6-085 MXNHO	840	1068	340	45,8	58,2	158,4	380	580	74
VA 6-105 MXNHO	840	1068	340	45,8	58,2	158,4	380	580	75

**Table 5.5 Dimensions and weights of the outdoor unit.**

### 5.5 Remote Controller

The remote control allows using the unit

### 5.6 Connections and Channels

This unit has the following connections and channels:

- Gas (G) and liquid channels (L): they carry the cooling agent between the outdoor and indoor unit.
- Discharge channels for condensed water (in the outdoor and indoor unit): they allow the water to be properly discharged which condenses during the normal operation of the unit.
- Electric connections: they supply electric energy to the unit.

### 5.7 Wall mounted type unit Accessories

This unit is provided with the accessories shown on Table 5.6.











No.	Accessory	Quantity
1	 Remote Control	1
2	 Remote Controller Bracket	1
3	 Batteries	2
4	 Mounting plate	1
5	 Piping support plate	1
6	Cushion	4
7	 Drainage elbow	1
8	 Cover	1
9	 Drain tube	1
10	 Steel nail, cement	6
11	 Screw caps	2
12	Wireclamp	1
13	Installation Manual	1
14	User Manual	1
15	Warranty cards	2

Table 5.6 Accessories supplied with the unit.

### 5.8 Cassette type unit Accessories

This unit is provided with the accessories shown on Table 5.7.







No.	Accessory	Quantity
1	 Remote Control	1
2	 Remote Controller Bracket	1
3	 Batteries	2
4	 Cushion	4
5	 Drainage elbow	1
6	 Screw caps	2
7	 Wireclamp	1
8	Installation Manual	1
9	User Manual	1
10	Warranty cards	2

Table 5.7 Accessories supplied with the unit.

### 5.9 Duct type unit Accessories

This unit is provided with the accessories shown on Table 5.8.



No.	Accessory	Quantity
1	 Wired remote control	2
2	 Screw caps	2
3	User Manual	2

Table 5.8 Accessories supplied with the unit.



## 5 Description of the Unit

### 5.10 Technical Specifications

Indoor Units	Units	VA 6-020 MXNHI	VA 6-025 MXNHI	VA 6-035 MXNHI	VA 10-020 MXNHI	VA 10-025 MXNHI
<b>Wall</b>						
<b>Capacity</b>						
Cooling Capacity	kW	<b>2.00</b>	<b>2.50</b>	<b>3.50</b>	<b>1,94</b>	<b>2.36</b>
Heating Capacity	kW	<b>2.30</b>	<b>2.90</b>	<b>3.80</b>	<b>2.26</b>	<b>2.76</b>
Air Flow	m <sup>3</sup> /h	450/400/370	500/450/400	600/550/500	380/430/480	390/450/520
Sound Power level	dB(A)	56/52/45	56/52/45	56/52/45	30/33/36	31/34/38
Net Dimensions (HxLxD)	mm	285x760x182	285x760x182	285x760x182	265x795x197	265x795x197
Net Weight	kg	8.6	8.6	8.6	7.6	7.6
Panel Net Weight	kg	/	/	/	/	/
Air Drop (static pressure)	Pa	/	/	/	/	/
<b>Pipe Connections</b>						
Pipe Connection liq/gas	inches	1/4-3/8	1/4-3/8	1/4-3/8	1/4-3/8	1/4-3/8

Indoor Units	Units	VA 10-035 MXNHI	VA 6-035 MXNHKI	VA 6-050 MXNHKI	VA 6-035 MXNHDI	VA 6-050 MXNHDI
		<b>Wall</b>	<b>Cassette</b>		<b>Duct</b>	
<b>Capacity</b>						
Cooling Capacity	kW	<b>3.10</b>	<b>3.24</b>	<b>5.03</b>	<b>3.61</b>	<b>5.15</b>
Heating Capacity	kW	<b>2.80</b>	<b>3.45</b>	<b>5.47</b>	<b>3.85</b>	<b>5.65</b>
Air Flow	m <sup>3</sup> /h	430/480/550	630/530/450	670/600/550	[550]/[500/450/400]	[1270]/[1160/1020/900]
Sound Power level	dB(A)	33/36/39	57/53/50	57/53/50	[56]/[53/51/48]	[59]/[57/53/51]
Net Dimensions (HxLxD)	mm	265x795x197	260x570x570	260x580x580	220x610x500	220x1090x500
Net Weight	kg	7.6	17	19	14	25
Panel Net Weight	kg	/	2.8	2.8		
Air Drop (static pressure)	Pa	/	/	/	20	20
<b>Pipe Connections</b>						
Pipe Connection liq/gas	inches	1/4-3/8	1/4-3/8	1/4-1/2 (includes connector for OU)	1/4-3/8	1/4-1/2 (includes connector for OU)

**Table 5.9 Technical specifications Indoor Unit.**

Outdoor Unit	Units	VA 6-060 MXNHO	VA 6-085 MXNHO	VA 6-105 MXNHO
Power Supply	V/Ph/Hz	230/1/50	230/1/50	230/1/50
Cooling Capacity	kW	<b>5.55</b>	<b>8.20</b>	<b>10.27</b>
Power Input	kW	1.72	2.47	3.27
Operating current	A	8,60	12,30	16,30
<b>Performance</b>				
Air Flow volume	m <sup>3</sup> /h	3200/2300/1600	4000/3200/2300	4300/3500/2600
Sound Power level	dB(A)	66/63/60	66/63/60	68/65/62
Refrigerant			R410A	
Refrigerant charge heat pump	gr	2000	2600	3000
Expansion system			Electronic expansion valve	
Dimensions (HxLxD)	mm	680x928x288	840x1068x340	840x1068x340
Net Weight	kg	54	74	75
<b>Pipe Connections</b>				
Pipe connection liq/gas		1/4-3/8	1/4-3/8	1/4-3/8
Max. Piping length (L1)	m	25	25	25
Max. L1+L2+L3+(L4 for the 4x1)	m	45	60	60
Max. Height IU under OU	m	10	10	10
Max. Height OU under IU	m	15	15	15
Chargeless length	m	30	40	40
Additional charge per m.	gr	20	20	20

**Table 5.10 Technical specifications Outdoor Unit.**

#### Note!

As part of its policy for ongoing improvements of its products, Vaillant reserves the right to modify these specifications without prior notice.

## 6 Transport



**Danger of injury and physical damage!**  
During transport and unloading, the unit could fall and injure anyone within the immediate vicinity. To avoid this:

- Use transport and lifting gear with suitable load capacity for the unit weight.
- Use the transport and lifting gear correctly (consult the respective user manuals).
- Use the slinging points provided for such a purpose on the unit.
- Secure the unit correctly.
- Use suitable personal protection equipment (helmet, gloves, safety boots and protective glasses).

## 7 Unpacking



**Danger of injury and physical damage!**  
During unpacking you could get cut and bruised. To avoid this:

- Use lifting gear with suitable load capacity for the unit weight.
- Use the transport and lifting gear correctly (consult the respective user manuals).
- Use the slinging points provided for such a purpose on the unit.
- Use suitable personal protection equipment (helmet, gloves, safety boots and protective glasses).

Unpack the unit and check that:

- The supply is complete.
  - All the elements are in perfect condition.
- Failing this, contact the manufacturer.



**Warning!**  
Protect the environment. Dispose of the packaging following the local standards in force. Do not dispose of it without the proper controls.

## 8 Installation

### 8.1 Qualification of the Installation Personnel

Ensure that this unit is installed by authorised personnel.

The personnel authorised by Vaillant must be suitably qualified and able to install the unit correctly.

### 8.2 General precautions to be taken into account before starting the installation



**Danger of injury and physical damage!**  
During unpacking you could get cut and bruised. To avoid this:

- Use lifting gear with suitable load capacity for the unit weight.
- Use the transport and lifting gear correctly (consult the respective user manuals).
- Use the slinging points provided for such a purpose on the unit.
- Use suitable personal protection equipment (helmet, gloves, safety boots and protective glasses).



**Danger of injury and physical damage!**  
The unit should be installed in accordance with the Regulations and Standards for refrigerator, electrical and mechanical installation prevailing in relation to the location of such installations.



**Danger!**  
**Danger of electric shock.**  
Connect the earth cable to the right line (not to the gas pipe, water pipe, lightning conductor or telephone line).



**Danger!**  
**Danger of electric shock.**  
Install differentials to avoid short-circuits.



**Warning!**  
Danger of breakdowns or malfunction.  
Use the pipes specifically intended for coolant for the cooling installation. Never use plumbing pipes.

## 8 Installation

### 8.3 General Installation Diagram with Wall mounted type units

**Warning!**  
 Danger of breakdowns or malfunction.  
 Observe the minimum assembly distances  
 indicated in Figure 8.1.

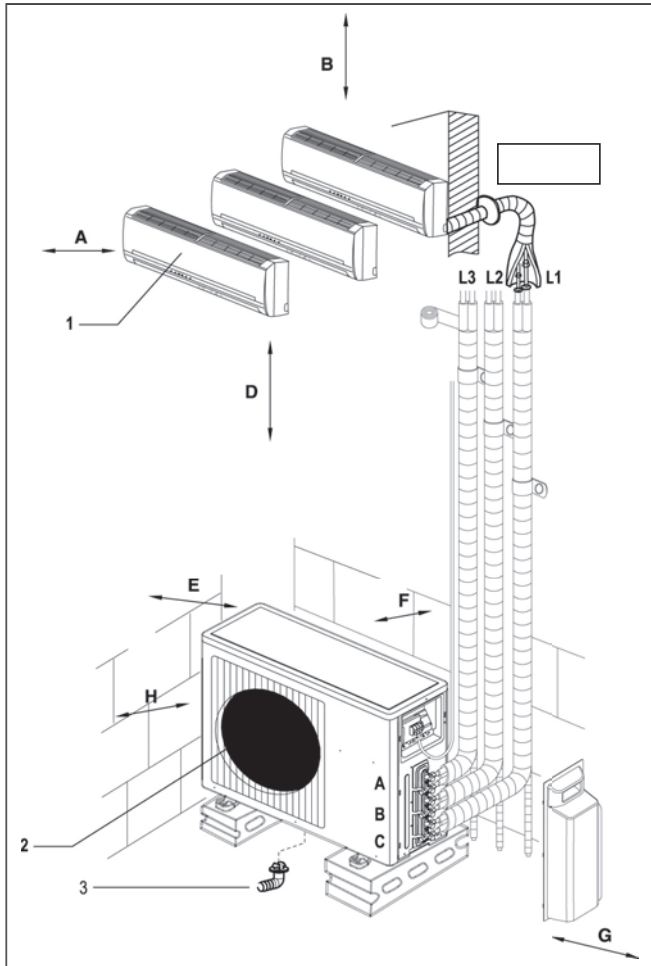

**Fig. 8.1** General diagram of the installation and the minimum assembly distances.

#### Legend

- 1 Indoor Unit
- 2 Outdoor Unit
- 3 Pipe for draining the condensed water
- A Front separation (minimum 10 cm)
- B Top separation in relation to the ceiling (minimum 5 cm)
- D Height in relation to the floor (minimum 2 m)
- E Side separation opposite side connections (minimum 10 cm)
- F Rear separation (minimum 10 cm)
- G Side separation connections side (minimum 15 cm)
- H Front separation (minimum 60 cm)

### 8.4 General Installation Diagram with Cassette type units

**Warning!**  
 Danger of breakdowns or malfunction.  
 Observe the minimum assembly distances  
 indicated in Figure 8.2 and 8.4.

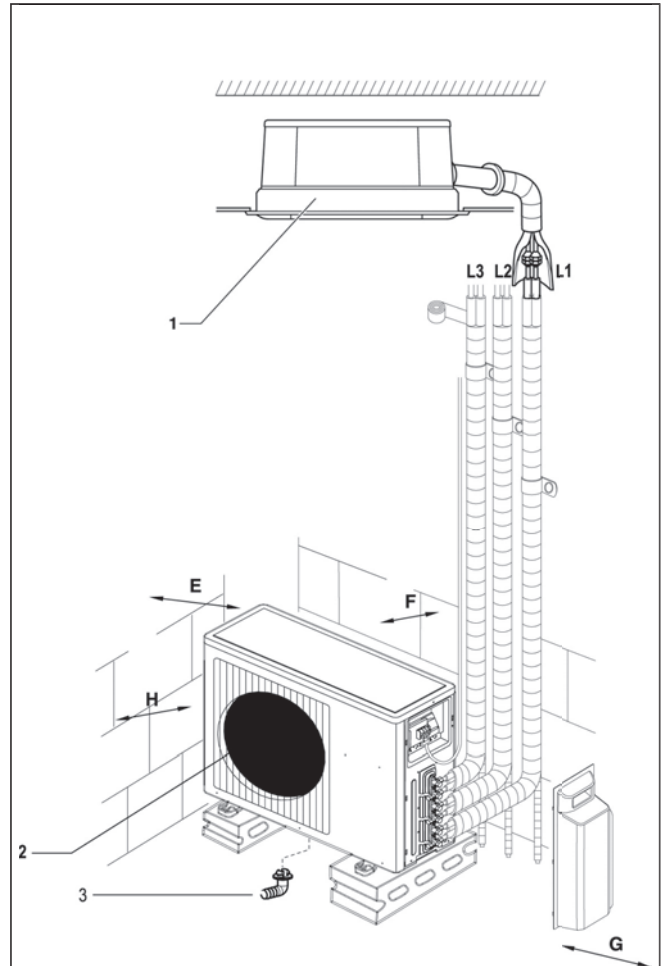

**Fig. 8.2** General diagram of the installation and the minimum assembly distances.

#### Legend

- 1 Indoor Unit
- 2 Outdoor Unit
- 3 Pipe for draining the condensed water
- E Side separation opposite side connections (minimum 10 cm)
- F Rear separation (minimum 10 cm)
- G Side separation connections side (minimum 15 cm)
- H Front separation (minimum 60 cm)

**8.5 General Installation Diagram with Duct type units**



**Warning!**  
 Danger of breakdowns or malfunction.  
 Observe the minimum assembly distances  
 indicated in Figure 8.3 and 8.5.

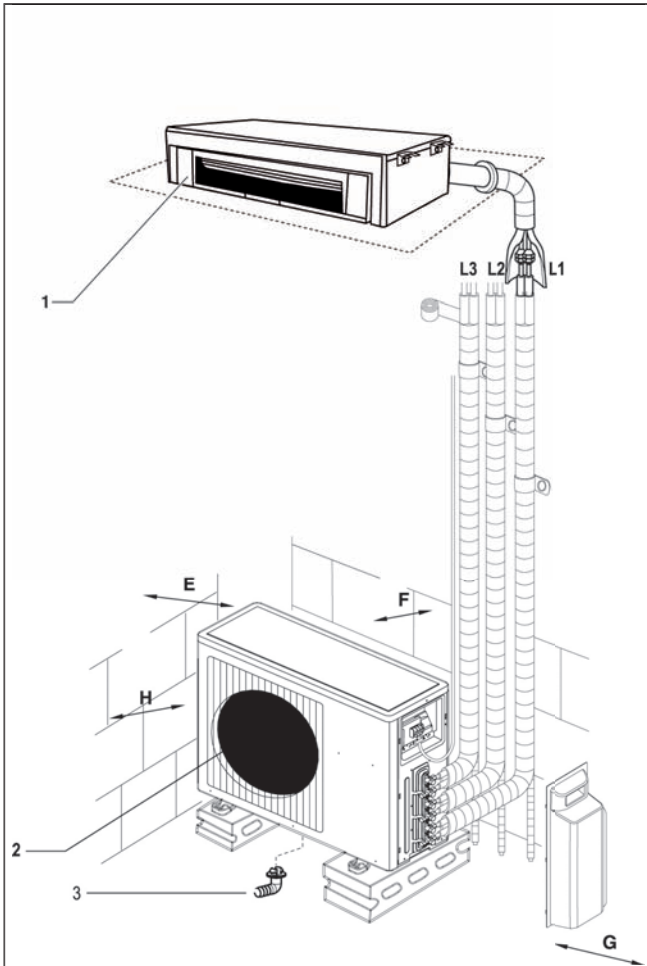

**Fig. 8.3 General diagram of the installation and the minimum assembly distances.**

**Legend**

- 1 Indoor Unit
- 2 Outdoor Unit
- 3 Pipe for draining the condensed water
- E Side separation opposite side connections (minimum 10 cm)
- F Rear separation (minimum 10 cm)
- G Side separation connections side (minimum 15 cm)
- H Front separation (minimum 60 cm)

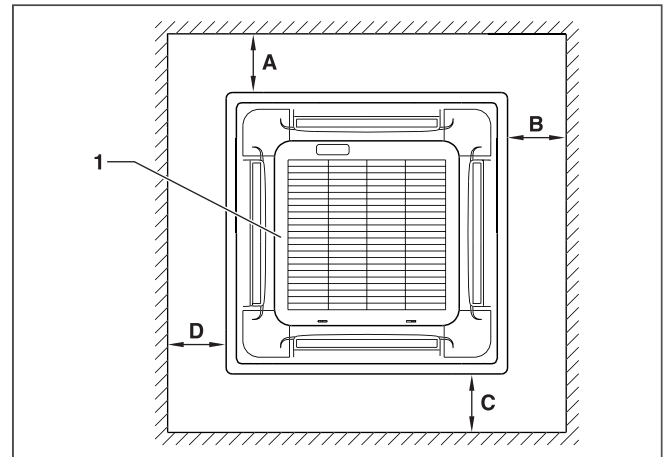

**Fig. 8.4 Minimum assembly distances (Cassette unit).**

MODEL	A	B	C	D
VA 6-035 MXNHKI	1000	1000	1000	1000
VA 6-050 MXNHKI	1000	1000	1000	1000

**Table 8.1 Indoor unit minimum assembly distances.**

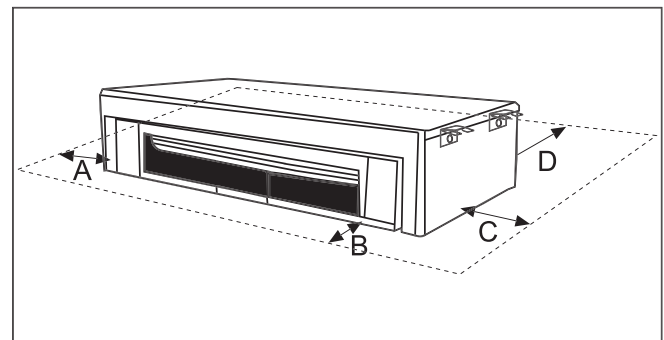

**Fig. 8.5 Minimum assembly distances (Duct type unit).**

MODEL	A	B	C	D
VA 6-035 MXNHDI	200	200	500	500
VA 6-050 MXNHDI	200	200	500	500

**Table 8.2 Indoor unit minimum assembly distances.**

## 9 Installation of the Wall Mounted Indoor Unit

### 9 Installation of the Wall Mounted Indoor Unit

#### 9.1 Selecting the Assembly Location

**Warning!**

Danger of breakdowns or malfunction. Observe the minimum assembly distances indicated in Figure 8.1.

**Note!**

If a hole already exists in the wall or a coolant pipe or condensed water pipe has already been installed, the base plate can be mounted to adapt to these conditions.

Recommendations:

- Install the indoor unit close to the ceiling.
- Choose a mounting site that will allow air to reach all parts of the room evenly. Avoid beams, installations or lights which obstruct the airflow.
- Install the indoor unit at an adequate distance from chairs or workstations in order to avoid unpleasant draughts.
- Avoid close heat sources.

#### 9.2 Fixing the Assembly Plate

Carry out the steps described below:

- Place the mounting plate on the chosen installation point.
- Level the plate horizontally and mark the holes to be made on the wall for the installation using the screws and rawplugs.
- Remove the plate.

**Warning!**

Danger of breaks in the domestic installation. Check that there are no electricity lines, pipes or any other element which could be impaired behind the spots where the holes are to be drilled.

If so, choose another installation location and repeat the aforementioned steps.

- Make the holes using a drill and insert the rawplugs.
- Place the assembly plate in the assembly location, level it horizontally and fix it with the screws and the rawplugs.

**Warning!**

Danger of breakdowns or malfunction. Ensure that the assembly plate has been correctly levelled. Otherwise, disassemble the plate and assemble it again correctly.

#### 9.3 Installation of the Pipes

##### 9.3.1 Methods for the Correct Discharge of the Condensed Water

**Warning!**

Danger of breakdowns or malfunction. Danger of condensed water spillage. In order to ensure that the unit drains correctly take the requirements described in this section into account.

Methods for the removal of the condensed water which is generated in the indoor unit:

- Condensed water can be allowed to drain naturally using the natural tilt of the condensed water pipe along with the coolant pipe. In order for it to be aesthetically pleasing, use a joint channel.
- The natural tilt of the condensed water pipe from the indoor unit to the container (washbasin, sink, etc.). Different invisible installation solutions also exist.
- Using an external pump for condensed water, carrying the condensed water to the outside or to the house drainage system.
- By natural tilt to the collector deposit for condensed water which is emptied using a pump for condensed water. The pump for condensed water receives a signal from the tank and takes the water from the tank conveying it to the outside or to the house drainage system.

**Note!**

This pump for condensed water is available as an original Vaillant accessory with the corresponding installation instructions.

**Warning!**

Danger of breakdowns or malfunction. Danger of condensed water spillage. To ensure that the unit carries out the drainage properly in the event of draining using a natural tilt, the condensed water pipe must also have a tilt from the indoor unit.

## 9.3.2 Handling the Coolant Pipes



**Danger!**  
**Danger of burns and eye injuries.**  
**In the event of soldering, use suitable protection equipment (protective soldering mask, soldering gloves, solderer clothing).**



**Warning!**  
**Danger of breakdowns or malfunction. Danger of wear in the coolant pipes.**  
**To ensure that the coolant pipes do not wear take the following points into consideration:**

- Use pipes specifically intended for cooling.



**Note!**  
**In specialised dealers you will find coolant pipes which are thermally insulated as a Vaillant accessory.**

- Ensure that the pipes are clean, dry and polished on the inside.
- The insulation of the pipes should be done using specific insulation for cooling.
- Observe the minimum and maximum pipe distances for each model.
- Do not bend the pipes where possible. When bending them, keep the radius as wide as possible to minimise load losses.
- If soldering, do so using strong welding (copper-silver alloy). During the soldering process a stream of dry nitrogen should be run through the inside of the pipes in order to avoid rusting.
- Only cut the coolant pipes using pipe cutters and always keep the pipe ends covered.
- Any flaring work should be performed meticulously in order to avoid subsequent losses of gas through the pipes.
- When reviving keep the pipe opening directed downwards in order to prevent shavings from getting into the pipes.
- Mount the joining tubes carefully, ensuring they cannot become displaced. Ensure that they will not cause traction in the joins.
- Equip the coolant pipes (inflow and outflow) separately and with thick diffusion heat insulation.
- Carefully squeeze the flaring connector, centring the flaring cone and the flanged nut. Applying excessive force without correctly centring can damage the thread and cause a reduction in the water tightness in the join.

## 9.3.3 Handling the Condensed Water Pipe



**Warning!**  
**Danger of breakdowns or malfunction. Danger of incorrect drainage of the condensed water and wear of materials due to dripping water.**  
**Take the following points into consideration:**

- Ensure that air circulates through the condensed water pipe in order to guarantee that the water can be freely released. Otherwise, the condensed water could leak through the indoor unit body.
- Mount the pipe without bending it in order to avoid blockage.
- If the water pipe is channelled outdoors, ensure that it is insulated against freezing.
- If the condensed water pipe is installed in a room, fit thermal insulation.
- Avoid installing the condensed water pipe with an ascending bend (see Figure 9.2).

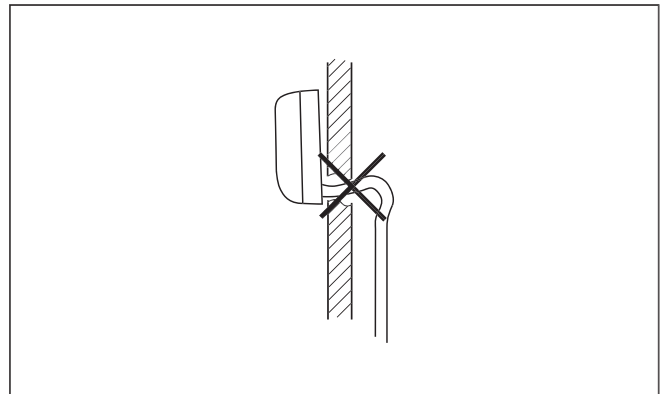

**Fig. 9.2 Avoid ascending bends.**

- Avoid installing the condensed water pipe with its free end submerged in water (see Figure 9.3).

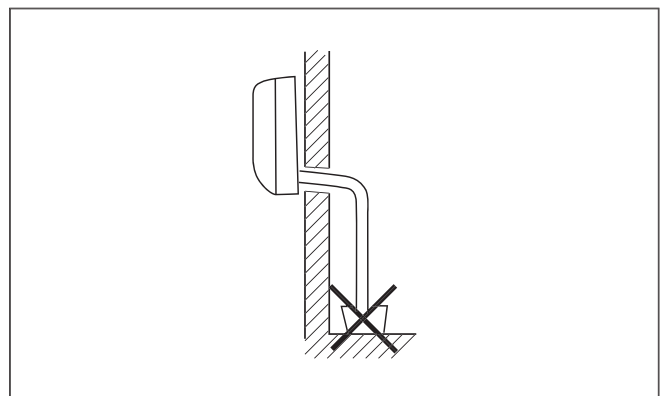

**Fig. 9.3 Avoiding submerging the end.**

- Avoid installing the condensed water pipe with crimping (see Figure 9.4).

## 9 Installation of the Wall Mounted Indoor Unit

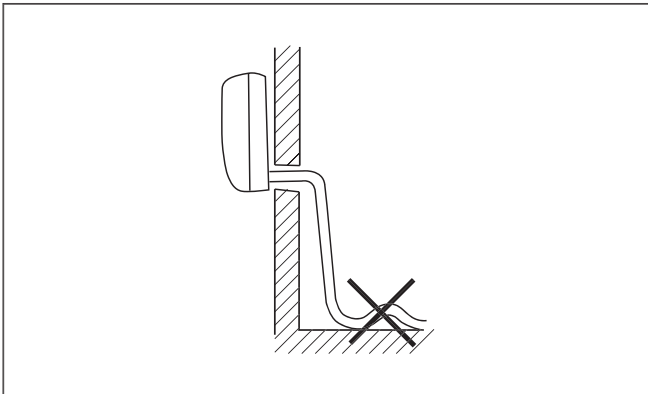

**Fig. 9.4 Avoid crimping.**

- Install the condensed water pipe in such a way that the distance of its free end from the floor is at least 5 cm (see Figure 9.5).

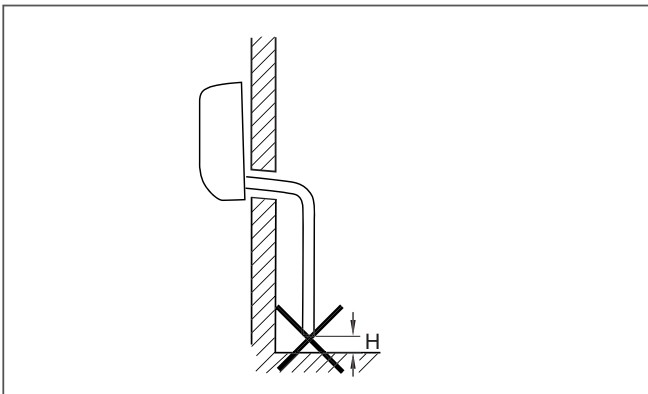
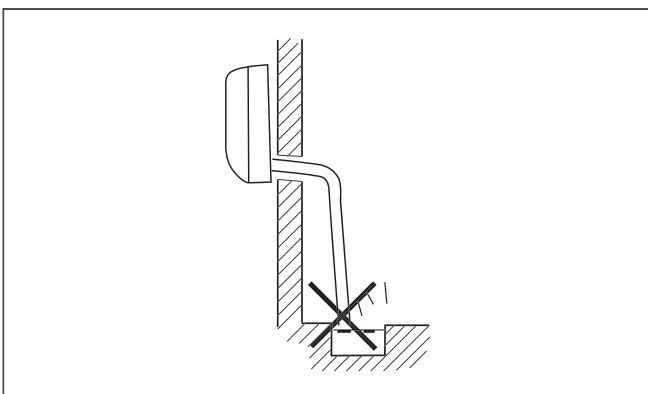

**Fig. 9.5 Minimum distance from the floor.**

### Legend

H Minimum distance from the floor: 5 cm

- Install the condensed water pipe in such a way that its free end is kept away from unpleasant odours to ensure that they do not penetrate the room (see Figure 9.6).



**Fig. 9.6 Avoids unpleasant odours.**

### 9.3.4 Making Holes for the Pipes

- Case A: laying the rear piping.  
In the event of laying the rear piping, a suitable hole must be made (see Figure 9.7).
- Drill a hole in accordance with the diameter indicated in Figure 9.7, slightly descending to the outside.

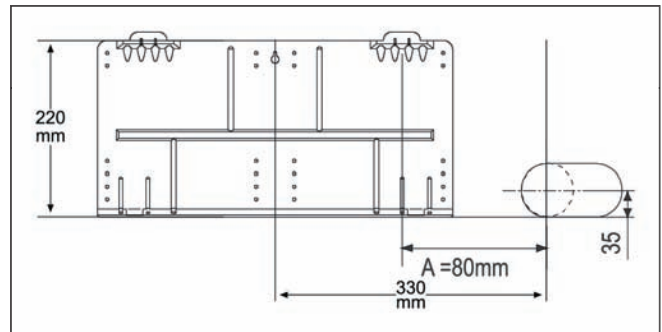

**Fig. 9.7 Dimensions of the hole for the piping.**

- Case B: laying the side or bottom piping.  
In this case holes do not have to be made on the wall since the indoor unit body has windows which can be opened to admit the pipes: choose the most adequate one for the desired outlet position (see Figure 9.8).
- Carefully break the chosen window on the lid using pliers.

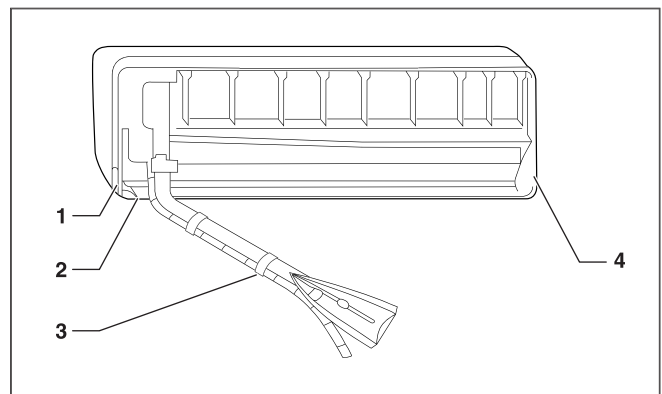

**Fig. 9.8 Windows for the installation of the pipes.**

### Legend

- 1 Lid for right piping
- 2 Lid for indoor piping
- 3 Securing with adhesive tape
- 4 Lid for left piping



## 9.3.5 Laying the Pipes

- If installing the rear piping:
  - Place the lid supplied for the hole in the piping and insert the coolant pipes with the condensed water pipe through the hole.
  - Seal the hole properly after installing the pipes.
- Carefully bend the installation pipe in the right direction.



### Warning!

Danger of breakdowns or malfunction. Danger of wear in the coolant pipes.

Bend the pipe carefully to prevent choking or breaks.

- Cut the pipes, leaving enough extra piping hanging over to enable the unit to be hooked up at the indoor unit joins.
- Insert the nut in the coolant pipe and carry out the flaring.
- Carefully remove the insulation of the flared connections in the indoor unit.
- Hang the indoor unit on the top edge of the mounting plate.
- Tilt the lower part of the indoor unit forwards and insert an auxiliary tool (e.g. a piece of wood) between the mounting plate and the unit (see Figure 9.9).

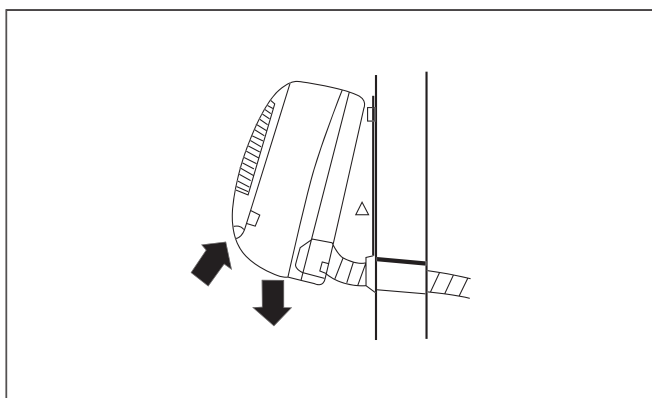

Fig. 9.9 Assembling the indoor unit.

- Connect the coolant pipes and the condensed water hose to the corresponding pipes and installation drain.
- Insulate the coolant piping correctly and separately. To do so, cover any possible cuts with masking tape or insulate any bare coolant piping with the corresponding insulation material used for cooling.

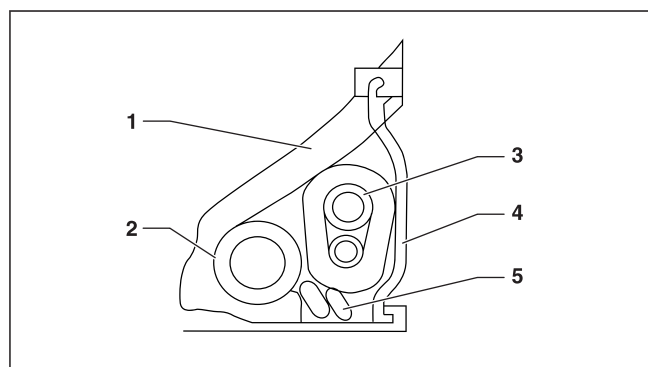

Fig. 9.10 Laying the Pipes.

### Legend

- 1 Heat-resistant material
- 2 Drain pipe
- 3 Coolant pipe
- 4 Piping support plate
- 5 Indoor/outdoor electric cable

- Insert the electric piping, connect the line on the indoor unit terminal strip and assemble the cabling covering (see section 13).
- Carry out the start up and the equipment functional test (see section 15).
- Fix the entire indoor unit (see section 9.3.6)..



### Note!

The connections in the flaring should be accessible in order to carry out the water tightness tests.

- Install the mounting plate, lining up the holes with the help of the plate.

## 9.3.6 Installation of the Indoor Unit Body

- Check that the installation has been carried out correctly and that there are no leaks (see section 15.1).
- Securely hang the indoor unit body onto the upper notches of the mounting plate. Briefly move the body from side to side to verify that it is secure.
- Lift the body up slightly from underneath, press it onto the mounting plate and then lower it vertically. The body will fit into the lower supports on the mounting plate.
- Check that the indoor unit is properly secured.
- In the event that the body does not slot into the supports properly, repeat this process.



# 10 Installation of the Cassette Indoor Unit

## 10 Installation of the Cassette Indoor Unit

### 10.1 General Warnings



**Warning!**

Outdoor units must be placed in accessible areas for subsequent maintenance and repair operations. Vaillant will not be responsible for any costs derived from incorrect positioning that prevents easy access.



**Danger of physical damage!**

To avoid the indoor unit from falling during the assembly, carry out the work with the help of a second person.



**Warning!**

Danger of deterioration of the indoor unit. When you lift the indoor unit, do so by supporting it at the four corners only. Avoid lifting the unit up by the condensation drainpipe or by the pipe connections.



**Warning!**

Danger of deterioration of the indoor unit drip tray. When you lift the indoor unit do not exert pressure on the drip tray to avoid damaging it.



**Warning!**

Danger of malfunction due to incorrect air circulation and the build-up of condensed water on the ceiling or in the lower part of the indoor unit. To avoid this, ensure that the lower part of the indoor unit is horizontally levelled and flush with the finished ceiling.



**Note!**

It is recommended to assemble the coolant pipes, remove condensed water and carry out the electrical installation before mounting the indoor unit in the ceiling and to make the connections immediately after mounting the indoor unit. This will provide you with more space.

### 10.2 Selecting the Assembly Location



**Danger of personal injury and material damage from collapse!**

Ensure that the ceiling and the fixing elements are able to withstand the weight of the indoor unit.



**Warning!**

Danger of breaks in the domestic installation. Check that there are no electricity lines, pipes or any other element which could be impaired behind the spots where the holes are to be drilled. If so, choose another installation location and repeat the aforementioned steps.



**Warning!**

Danger of breakdowns or malfunction. Observe the minimum assembly distances indicated in Figure 8.2 and 8.4.



**Note!**

The indoor unit can be installed with the false ceiling fitted or not fitted.

#### Recommendations

- Choose a mounting site that will allow air to reach all parts of the room evenly. Avoid beams, installations or lights which obstruct the airflow.
- Install the indoor unit at an adequate distance from chairs or workstations in order to avoid unpleasant draughts.
- Avoid close heat sources.
- Ensure you leave sufficient space for carrying out connection and inspection tasks of the indoor unit.



**Warning!**

Danger of breakdowns or malfunction. Ensure that the assembly plate has been correctly levelled. Otherwise, disassemble the plate and assemble it again correctly.

## 10.3 Recommended Installation Process

It is recommended carrying out the installation in the following order:

- Installation of the condensed water pipe.
- Installation of the coolant pipes.
- Installation of the fresh air and bypass lines.
- Electrical installation.
- Indoor unit assembly in the ceiling.
- Connections.
- Checking for leaks and starting the unit.
- Assembly of the decorative panel.

## 10.4 Installation of the Condensed Water Pipe

### 10.4.1 Handling the Condensed Water Pipe



#### Warning!

Danger of breakdowns or malfunction. Danger of incorrect drainage of the condensed water and wear of materials due to dripping water.

Take the following points into consideration:

- Ensure that air circulates through the condensed water pipe in order to guarantee that the water can be freely released. Otherwise, the condensed water could leak through the indoor unit body.
- Mount the pipe without bending it in order to avoid blockage.
- If the water pipe is channelled outdoors, ensure that it is insulated against freezing.
- If the condensed water pipe is installed in a room, fit thermal insulation.
- Avoid installing the condensed water pipe with an ascending bend.
- Avoid installing the condensed water pipe with its free end submerged in water.
- Avoid installing the condensed water pipe with crimping.
- Install the condensed water pipe in such a way that the distance of its free end from the floor is at least 5 cm.
- Install the condensed water pipe in such a way that its free end is kept away from unpleasant odours to ensure that they do not penetrate the room.

### 10.4.2 Laying of the Condensed Water Pipe



#### Note!

The indoor unit is fitted with a condensed water removal pump.



#### Note!

Use a pipe whose diameter is at least the same as the diameter of the indoor unit connection (polyethylene pipe: inner diameter 25 mm, outer diameter 32 mm).

- Plan the layout of the condensed water pipe taking into account the indications in section 10.4.1.
  - Ensure that the pipe is as short as possible.
  - Ensure that the minimum inclination from the indoor unit is at least 1%.
- Mount the pipe supports taking into account the distances and inclinations indicated in figure 10.1.

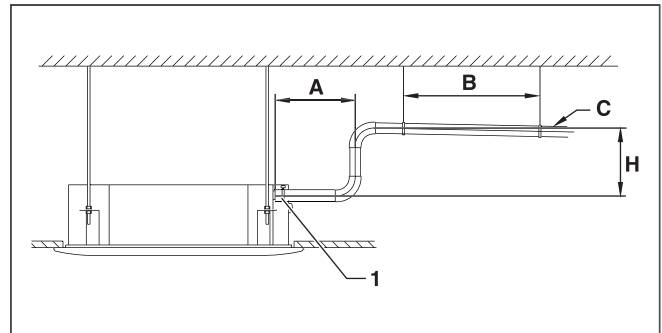

**Fig. 10.1 Installation diagram of the Pipe for the Drainage of the Condensed Water.**

#### Legend

- 1 Pump flange (jacketing)
- A Distance with regard to the indoor unit (maximum 200 mm)
- B Distance between supports (maximum 1 - 1.50 m)
- C Pipe inclination (minimum 1%)
- H Maximum height of the pipe with regard to the pump (maximum 500 mm)

- Mount the condensed water pipe in its supports.
  - Prevent the pipe from bulging to guarantee the correct removal of the water.
- Insulate the pipe with thermal insulation.

# 10 Installation of the Cassette Indoor Unit

## 10.5 Installation of the Coolant pipes

### 10.5.1 Handling the Coolant Pipes



**Danger!**  
**Danger of burns and eye injuries.**  
In the event of soldering, use suitable protection equipment (protective soldering mask, soldering gloves, solderer clothing).



**Warning!**  
Danger of breakdowns or malfunction. Danger of wear in the coolant pipes.

To ensure that the coolant pipes do not wear take the following points into consideration:

- Use pipes specifically intended for cooling.
- Ensure that the pipes are clean, dry and polished on the inside.
- The insulation of the pipes should be done using specific insulation for cooling.
- Observe the minimum and maximum pipe distances for each model.
- Do not bend the pipes where possible. When bending them, keep the radius as wide as possible to minimise load losses.
- If soldering, do so using strong welding (copper-silver alloy). During the soldering process a stream of dry nitrogen should be run through the inside of the pipes in order to avoid rusting.
- Only cut the coolant pipes using pipe cutters and always keep the pipe ends covered.
- Any flaring work should be performed meticulously in order to avoid subsequent losses of gas through the pipes.
- When reviving keep the pipe opening directed downwards in order to prevent shavings from getting into the pipes.
- Mount the joining tubes carefully, ensuring they cannot become displaced. Ensure that they will not cause traction in the joints.
- Equip the coolant pipes (inflow and outflow) separately and with high density heat insulation.
- Carefully squeeze the flaring connector, centring the flaring cone and the flanged nut. Applying excessive force without correctly centring can damage the thread and cause a reduction in the water tightness in the join.



**Note!**  
In specialised dealers you will find coolant pipes which are thermally insulated as a Vaillant accessory.

### 10.5.2 Laying of the Coolant Pipes



**Note!**  
Ensure that after mounting there is enough space for accessing the indoor unit connections.

- Carefully bend the installation pipe in the right direction.



**Warning!**  
Danger of breakdowns or malfunction.  
Danger of wear in the coolant pipes.  
Bend the pipe carefully to prevent choking or breaks.

- Position the pipes in the runoff provided.
- Cut the pipes, leaving enough extra piping hanging over to enable the unit to be hooked up at the indoor unit joins.
- Insert the nut in the coolant pipe and carry out the flaring.
- Insulate the coolant piping correctly and separately (figure 10.2). To do so, cover any possible cuts with masking tape or insulate any bare coolant piping with the corresponding insulation material used for cooling.

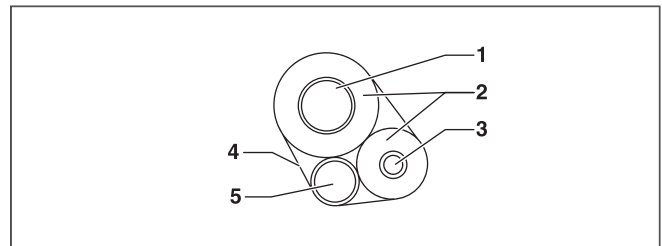

**Fig. 10.2 Pipe Insulation.**

#### Legend

- 1 Coolant pipe (gas)
- 2 Insulation
- 3 Coolant pipe (liquid)
- 4 Winding
- 5 Condensed water drainpipe

## 10.6 Installation of the Fresh Air

**Note!**  
Only applicable to the models indicated in table 10.1.

MODEL	FRESH AIR
VA 6-035 MXNHKI	YES
VA 6-050 MXNHKI	YES

**Table 10.1 Models with lines available for renewing fresh air.**

The side opening allows installing pipes for air intake from outside and pipe shunting to be installed (see figure 10.3).

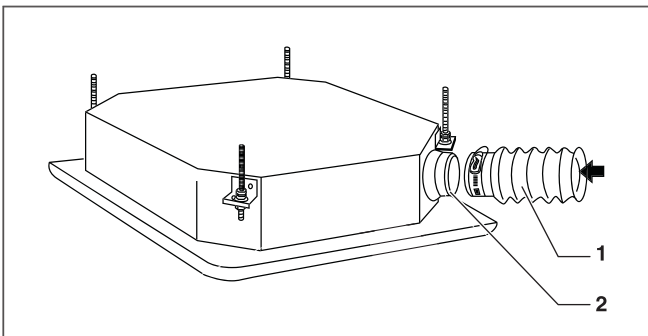

**Fig. 10.3 Fresh air line.**

### Legend

- 1 Flange on the fresh air line
- 2 Fresh air line

Carry out the following operations:

- Select the lines. Use lines with the following characteristics:
  - Base material: flexible polyester with spring interior or corrugated aluminium.
  - Diameter: 101,6 mm.
  - External anti-condensation lining: fibreglass, 12-25 mm thick.
- Install the lines.

## 10.7 Indoor Unit Assembly in the Ceiling

**Note!**  
The indoor unit is fixed to the ceiling using hooks and hanging bars (threaded varilla M10), with its corresponding nuts, locknuts and washers.

- Draw the position of the fixing elements according to the indicated measurements.
  - Observe the minimum assembly distances (see section 8.4).
- Adapt the length of the threaded rods to the correct measurement.
- Mount the fixing bars in the points provided (optionally, you can use hooks fixed to the ceiling and hang the fixing bars from them).

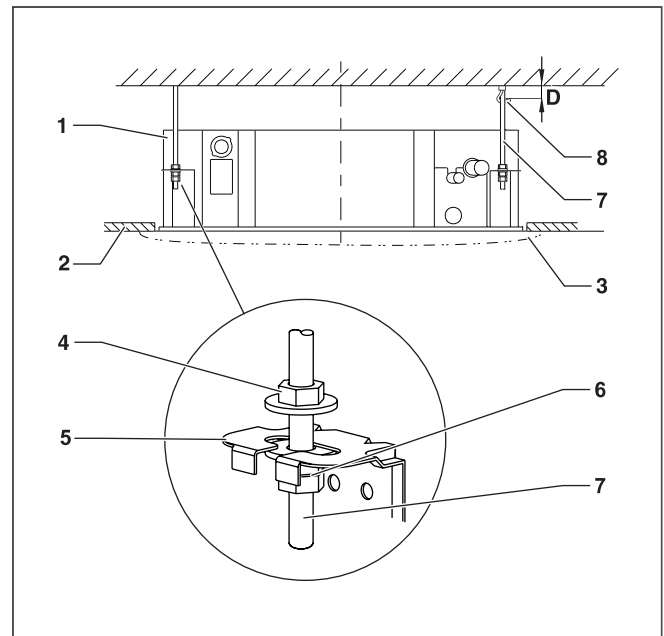

**Fig. 10.4 Indoor unit assembly diagram.**

### Legend

- 1 Indoor Unit
- 2 False ceiling
- 3 Decorative panel
- 4 Upper fixing nut
- 5 Indoor unit support
- 6 Nut-locknut set
- 7 Fixing bar
- 8 Fixing hook (optional)
- D Distance of the hook to the ceiling (34 mm)

- Position a nut in each fixing bar (which will remain above the unit support) and a nut-locknut set (which will remain below the support). See assembly diagram in figure 10.4.

## 10 Installation of the Cassette Indoor Unit

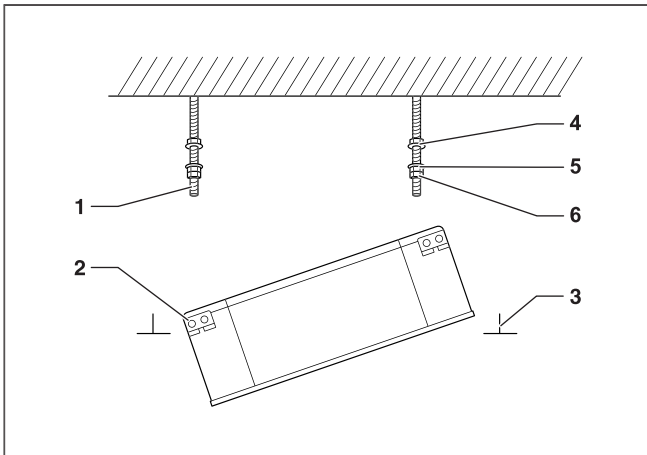

**Fig. 10.5 Introduction of the indoor unit via the opening in the false ceiling.**

### Legend

- 1 Fixing bar
- 2 Indoor unit support
- 3 False ceiling
- 4 Upper fixing nut
- 5 Lower fixing nut
- 6 Locknut

- If there should be a false ceiling, lift the indoor unit (see warnings in section 10.1), tilt slightly and introduce it via the opening in the false ceiling (see figure 10.5).
- Position the indoor unit in such a way that its fixing supports remain positioned between the nut and the nut-locknut set (see figure 10.4).
- Regulate lower fixing nuts in such a way that the indoor unit is horizontally levelled and at the correct height (flush with the lower part of the false ceiling).
- Tighten the upper fixing nuts and locknuts.

### 10.8 Connections

- Carefully remove the insulation of the flared connections in the indoor unit.
- Connect the coolant pipes and the condensed water hose to the corresponding pipes and installation drain.
- Thermally insulate the coolant pipe and condensed water connections.
- In the event of installing cold air and bypass lines:
  - Cut and remove the anti-condensation insulation in the indoor unit.
  - Connect the lines to the indoor unit (see figure 10.3).
- Carry out the electrical connection (see section 13).



### Note!

The connections in the flaring should be accessible in order to carry out the water tightness tests.

### 10.9 Installation of the decorative panel



#### Warning!

Danger of breakdowns or malfunction.

Danger of condensed water escaping and the appearance of anomalies in the display.

In order to avoid this, ensure that the decorative panel is correctly installed.



#### Note!

Previously, carry out the start up and the equipment functional test (see section 15).

- Check that the false ceiling is completed and that the size of the opening is suitable (the opening should not be visible after assembly of the cover).
- Ensure that the indoor unit is horizontally levelled and that it is flush with the lower part of the false ceiling once this has been completed.
- Position the decorative panel in a position which ensures that the Air Swing motor does not remain below the coolant pipes.
- Provisionally fix the decorative panel screws and level the decorative panel.
- Firmly tighten the decorative panel screws.
- Connect the synchronous motor cables and the signal lines.
- Carry out a function test with the remote control.
- If there is no response to the remote control signal: check the connection and repeat the function test 10 seconds after disconnecting the power supply.

## 11 Installation of the Duct Indoor Unit

### 11.1 Initial check

- Install the indoor unit leaving sufficient space around the same as to allow handling and maintenance tasks, as shown in the figure.
- Do not allow obstacles to block the air connection or discharge flow.
- Do not install the indoor unit in a machinery workshop or kitchen in which there is oil or fumes in the air which may flow towards the indoor unit. The oil will become deposited on the heat interchanger, resulting in poor performance by the unit. It may even result the deforming or breakage of the plastic parts of the indoor unit.
- Pay special care with regards to the following points when the indoor unit is installed in a hospital or any other area in which there are electromagnetic waves from medical equipment:
  - A) Do not install the indoor unit in a place in which the electromagnetic waves will have a direct influence on the electrical box, on the remote control switch or on the remote control cable.
  - B) Install the unit as far away as possible from the source of electromagnetic waves. Place it at a distance of at least 3 metres.
  - C) Install a noise filter when the power source produces unpleasant noise.
  - D) Choose the final location and the installation direction of the internal unit with special attention to the pipes and cables and to maintenance.
  - E) When determining the location of the indoor unit, give consideration to the air conducts network, favouring the distribution of the same.

### 11.2 Attachment of the indoor unit

Mount the suitable attachments for each type of structure, paying special attention to the possible transmission of vibration and noise, installing, if necessary, anti-vibration and soundproofing elements.

### 11.3 Installation of the indoor unit

- Introduce and twist a nut on each of the rods.
- Raise the indoor unit, introducing the rods in the suspension support holes.
- Position a washer and a nut on each of the rods.
- Level the machine and secure it, tightening in such a manner as one nut pressures the other.
- We recommend positioning a counternut for the nut placed on the lower part of the suspension rods.
- This indoor unit is initially designed for positioning in false ceilings; when installing in an area of direct access, protect the electrical connection strip in order to prevent accidents.

### 11.4 Installation of the drainage pipe

- Take special care when installing the drainage pipes of the unit, since problems with the same may result in spillage of the condensed water of the evaporator. The unit is equipped with a drainage connection.
- Do not place the drainage pipe in an ascending position, since the drainage water would return to the unit and spill over when the unit is halted.
- Do not connect the drainage pipe to the sanitary outflows, waste water pipes or any other drainage pipe without installing a siphon.
- When the drainage pipe is connected to other indoor units, the connection positions of each unit must be higher than the common drainage pipe. The length of the common pipe must correspond with the size and number of existing units.

### 11.5 Hanging the indoor unit

Mount the unit as shown in the figure.

Parts supplied by the installer:

- Rod, nut and washer.

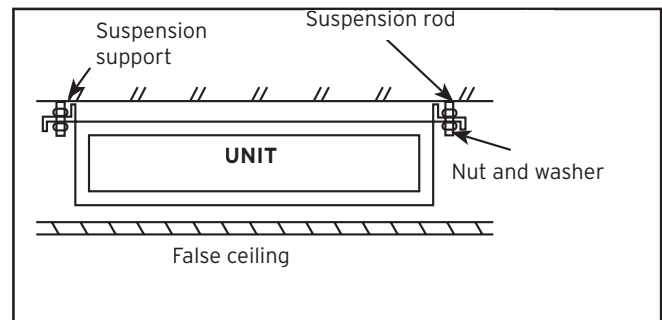
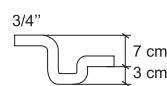

Figure 11.1



**Note!**

**It is important to place a siphon on each outflow.**

## 12 Installation of the Outdoor Unit

### 12 Installation of the Outdoor Unit

#### 12.1 Selecting the Assembly Location



**Danger of personal injury and material damage from explosion!**  
Install the unit away from gases or inflammable or easily combustible substances and free from thick dust formation.



**Danger of personal injury and material damage from collapse!**  
Ensure that the ground can withstand the weight of the outdoor unit and allow it to fit in a horizontal position.



**Warning!**  
Danger of corrosion.  
Do not install the unit near to corrosive materials.

- The outdoor unit can only be mounted outdoors, never inside a building.
- Do not install the unit in such a way that the air current affects the air inlets of premises nearby.
- If possible avoid direct sunlight.
- Ensure that the ground has sufficient rigidity to avoid vibrations.
- Check that there is sufficient space to observe the minimum distances (see Figure 121).
- Check that neighbours are not disturbed by draughts or noise.
- If the premises are rented obtain the owner's consent.
- Comply with local regulations: there are considerable differences depending on the area.
- Leave enough space to fit the condensed water drainage pipe (see section 12.4).

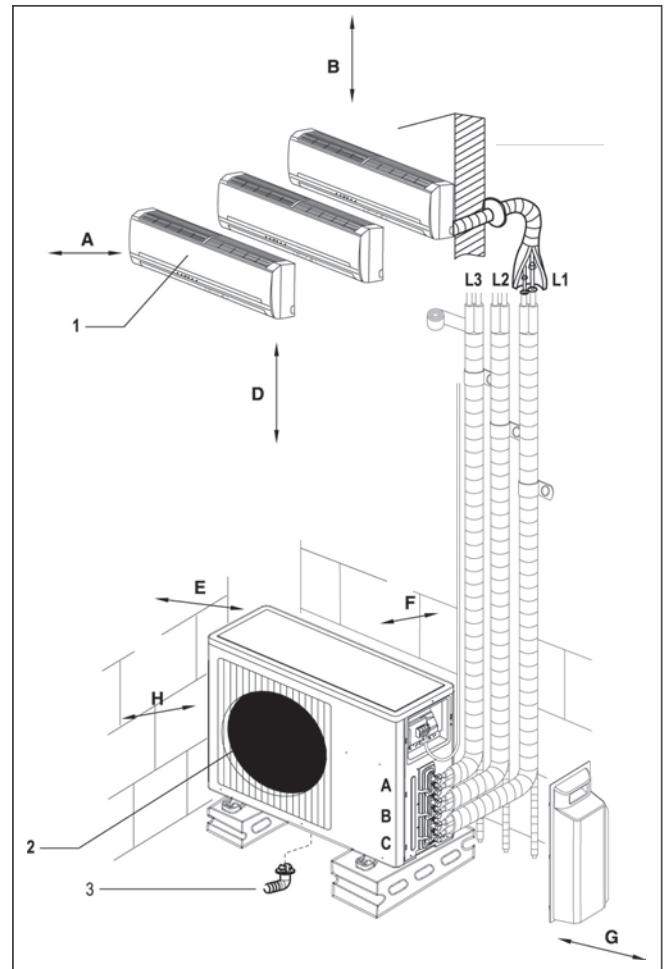

**Fig. 12.1 General diagram of the installation and the minimum assembly distances.**

#### Legend

- 1 Indoor Unit
- 2 Outdoor Unit
- 3 Pipe for draining the condensed water
- A Front separation (minimum 10 cm)
- B Top separation in relation to the ceiling (minimum 5 cm)
- D Height in relation to the floor (minimum 2 m)
- E Side separation opposite side connections (minimum 10 cm)
- F Rear separation (minimum 10 cm)
- G Side separation connections side (minimum 15 cm)
- H Front separation (minimum 60 cm)



## 12.2 Planning the Coolant Return

The coolant circuit contains a special oil to lubricate the outdoor unit compressor. To assist the return of the oil to the compressor the following is recommended:

- that the indoor unit is located higher than the outdoor unit and,
- that the suction pipe (the thickest one) is assembled with the tilt towards the compressor.

If the outdoor unit is mounted higher than the indoor unit, the suction pipe must be mounted in a vertical position. At heights exceeding 7.5 m:

- an additional oil deposit should be installed at each 7.5 m interval to collect the oil and suction it, returning it to the outdoor unit and
- an elbow can be installed in front of the outdoor unit to further assist the oil return.

## 12.3 Connection of the Coolant Pipes

### Note!

Installation is easier if the gas suction pipe is connected up first. The suction pipe is the thickest one.

- Mount the outdoor unit in the designated site.
- Remove the protection hoods from the coolant joints in the outdoor unit.
- Carefully bend the installed pipe towards the outdoor unit.



### Warning!

**Danger of breakdowns or malfunction. Danger of wear in the coolant pipes.**  
Bend the pipe carefully to prevent choking or breaks.

- Cut the pipes, leaving enough extra piping hanging over to enable the unit to be hooked up at the outdoor unit joins.
- Flare the coolant pipe when installed.
- Join the coolant pipes to the corresponding outdoor unit connection.
- Insulate the coolant piping correctly and separately. To do so, cover any possible cuts with masking tape or insulate any bare coolant piping with the corresponding insulation material used for cooling.

## 12.4 Connection of the Pipe for the Drainage of the Condensed Water



### Note!

Applicable only to those units that have built-in heat pumps.

Whilst the unit is running with the heat pump function, condensation forms in the outdoor unit and has to be drained.

- Insert the elbow included in the supply in the hole provided at the bottom of the outdoor unit and turn it 90° to fix it (see Figure 12.2).

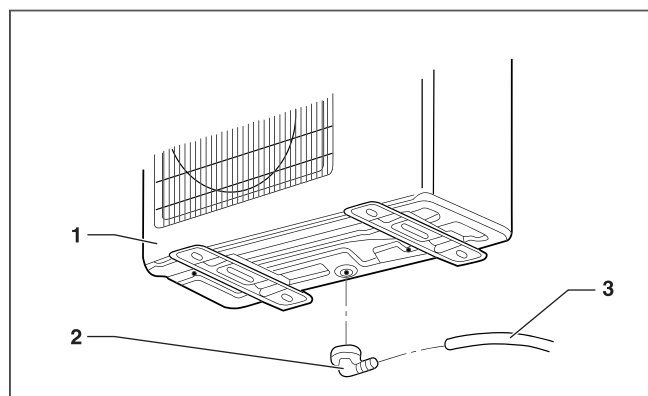

**Fig. 12.2 Assembly of the drainage elbow for condensed water.**

### Legend

- 1 Outdoor Unit
- 2 Drainage elbow
- 3 Drainage hose

- Mount the drainage hose ensuring that it leaves the equipment at a tilt.
- Verify the correct drainage of the water by pouring the water into a collection tray located at the bottom of the outdoor unit.
- Protect the condensed water hose with thermal insulation to avoid freezing.



## 13 Electric Wiring

### 13.1 Safety Precautions



**Danger!**  
Danger of electric shock.  
Before connecting the unit to the electric supply line, ensure that the line is not live.



**Danger!**  
Danger of electric shock.  
If the mains cable is damaged, it must be replaced by the manufacturer, the head of maintenance or a similarly qualified person.



**Danger!**  
Danger of electric shock.  
Ensure that the power line is equipped with a bipolar or tetrapolar switch according to the model, (single phase or three-phase) with a distance of at least 3 mm between contacts (Standard EN-60335-2-40).



**Danger!**  
Danger of electric shock.  
Equip the installation with protection against short-circuits to avoid electric shocks. This is a legal requirement.



**Danger!**  
Danger of electric shock.  
Use an electric plug which perfectly adapts to the electric power supply wiring.



**Danger!**  
Danger of electric shock.  
Use wiring in accordance with the respective local, national and international wiring standards regarding installation in technical electrics.



**Danger!**  
Danger of electric shock.  
Use an approved electric plug and power supply cable.



**Warning!**  
Danger of breakdowns or malfunction.  
Size the electric wiring with sufficient capacity.



**Warning!**  
Danger of breakdowns or malfunction.  
Compliance with the Standard EN 61000-3-11:  
Check that the nominal power of the main phase current connection is > 100.



**Warning!**  
Danger of breakdowns or malfunction.  
Ensure that the supplied power voltage is in the range of 90% to 110% of the rated voltage.



**Warning!**  
Install the unit in such a way that the electric plug is easily accessible. Thus, if required, the unit can be quickly disconnected.

### 13.2 Remark with regard to Directive 89/336/EEC

In order to prevent electromagnetic interference during the start up of the compressor (technical process), the following installation conditions must be adhered to.

- Make the air conditioning unit power supply connection at the main power distribution. Carry out the distribution with low impedance. Normally the required impedance is reached at a 32 A fusing point.
- Check that no other equipment is connected to this power supply line.



**Note!**  
For more detailed information on the electric installation, please consult the Technical Connection Conditions applied by your electricity supply board.



**Note!**  
In order to obtain more information with regard to power details of the air conditioner consult the unit rating plate.

### 13.3 Electric Connection of the Indoor Unit

**Warning!**

Danger of breakdowns or malfunction. If the fuse on the PC board is blown please change it with type T. 3,15A/250V.

- Disassemble the outdoor body of the indoor unit by pulling it upwards.
- Remove the wiring cover on the right of the body by unscrewing it (see Figure 13.1).

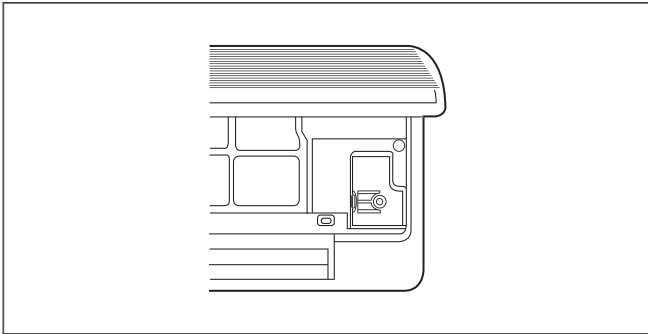

**Fig. 13.1** Wiring Cover.

- Insert the cable from the outside:
  - Using the same hole through which the coolant pipes are installed (or are going to be installed later) or,
  - Using another of the pipe installation windows provided on the body.
- Pull the electrical cable from the rear of the indoor unit through the specific hole in the front.
- Connect the line on the terminal strip of the indoor unit according to the corresponding wiring diagram (see Figures).

## 13 Electric Wiring

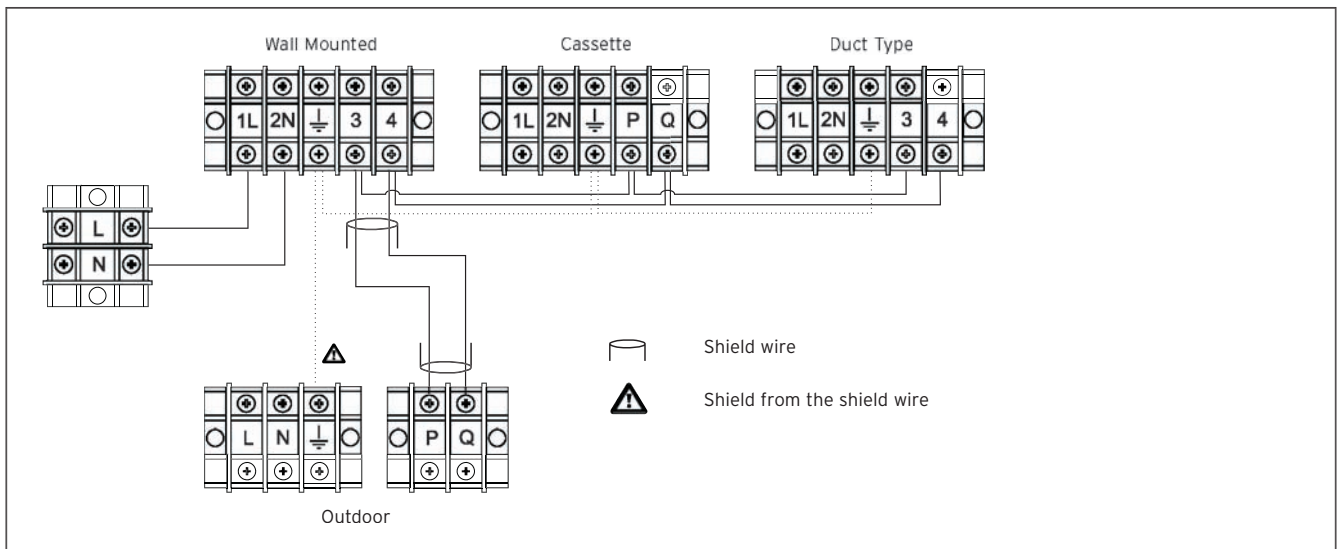

Fig. 13.2 Wiring indoor unit.



**Warning!**

The cable between inputs 3 and 4 of the indoor units and C1 and C2 of the outdoor unit should be shielded and must be correctly earthed. Otherwise the machine will not work.



**Warning!**

Installation should be done with a proper earth connection and each unit should be properly earthed. Otherwise the machine will not work.

- Secure the cable installed with the outdoor unit's contracting device.
- Check that the cables are correctly secured and connected.
- Mount the protective wiring cover.

## 13.4 Electric Characteristics

		VA 6-050 MXNHO	VA 6-085 MXNHO	VA 6-105 MXNHO	VA 6-020 MXNHI	VA 6-025 MXNHI	VA 6-035 MXNHI	
Voltage (V/Ph/Hz)		230/1/50	230/1/50	230/1/50	230/1/50	230/1/50	230/1/50	
Supply	Supply section up to 25 meter (in mm <sup>2</sup> )	2,5	4	4	1,5	1,5	1,5	
	Indoor/Outdoor	Outdoor	Outdoor	Outdoor	Indoor	Indoor	Indoor	
	Thermal-magnetic circuit breaker, type D (A)	16	20	20	10	10	10	
Interconnection section up to 25 meter (mm <sup>2</sup> )		0,8	0,8	0,8				
Inteconnect Shield or not (YES/NO)		YES	YES	YES				
Immediatte residual current protector (A)		0,03	0,03	0,03	0,03	0,03	0,03	
		VA 10-020 MXNHI	VA 10-025 MXNHI	VA 10-035 MXNHI	VA 6-035 MXNHKI	VA 6-050 MXNHKI	VA 6-035 MXNHDI	VA 6-050 MXNHDI
Voltage (V/Ph/Hz)		230/1/50	230/1/50	230/1/50	230/1/50	230/1/50	230/1/50	230/1/50
Supply	Supply section up to 25 meter (in mm <sup>2</sup> )	1,5	1,5	1,5	1,5	1,5	1,5	1,5
	Indoor/Outdoor	Indoor	Indoor	Indoor	Indoor	Indoor	Indoor	Inneneinheit
	Thermal-magnetic circuit breaker, type D (A)	10	10	10	10	10	10	10
Interconnection section up to 25 meter (mm <sup>2</sup> )								
Inteconnect Shield or not (YES/NO)								
Immediatte residual current protector (A)		0,03	0,03	0,03	0,03	0,03	0,03	0,03

Table 13.1 Electric Characteristics.

## 14 Communication between the Indoor and Outdoor Units

Once the installation has been performed, the remote control must be used to identify each indoor unit with its corresponding key pair. To do so, follow this procedure:

**Warning!**  
 Before setting up the communication between units, the installation process must have fully completed, both the refrigerant and electrical parts, and the valve keys must be open. Otherwise the installation process will report an error and will not function.

**Note!**  
 Each unit must have the following setup:

- With the indoor unit connected to valve A (see installation layout), the direction should be "1"
- With the indoor unit connected to valve B (see installation layout), the direction should be "2"
- With the indoor unit connected to valve C (see installation layout), the direction should be "3"
- With the indoor unit connected to valve D (see installation layout), the direction should be "4"

### 14.1 Address setting for Cassette and V6 Wall Indoors by using the remote

- Power all units.
- Put the indoor unit in "Stand By" mode by pressing the "OFF" button.
- For each unit, the following steps should be followed:
  - Press the emergency button for 15 seconds as shown in figure 13.1 for wall type and 13.2 for cassette and you will hear 4 beeps. Release the emergency button.
  - Switch on the indoor unit with the remote control by pressing the "ON" button. When the unit switches on, it automatically goes into direction setup mode.
  - To set the direction of the indoor unit, just press the "SLEEP" button. Depending on the number of times you press it, the setup will vary:
    - By pressing once, the direction is "1" and the LED TIMER flashes once only
    - By pressing twice, the direction is "2" and the LED TIMER flashes twice
    - By pressing three times, the direction is "3" and the LED TIMER flashes three times
    - By pressing four times, the direction is "4" and the LED TIMER flashes four times
- Switch off the unit using the "OFF" button and the direction will be set
- This process should be repeated for each indoor unit.

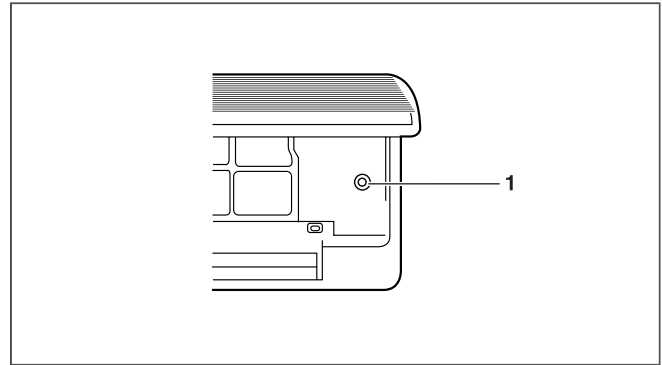

Fig. 14.1 Emergency operation/operation test switch.

**Legend**

- 1 Emergency operation/operation test switch

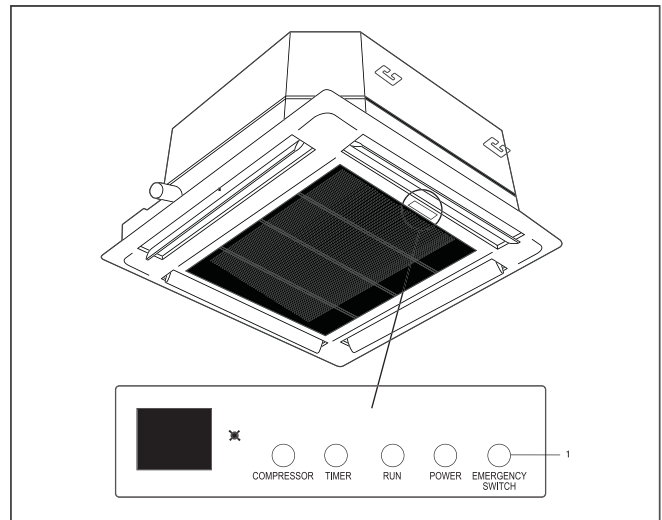

Fig. 14.2 Emergency operation/operation test switch.

**Legend**

- 1 Emergency operation/operation test switch

**Note!**  
 If you wish to know the direction configured in the Indoor unit, press the emergency button for 20 seconds and you will hear 5 beeps. Following, the LED TIMER will flicker as many times as the direction configures in the unit.

Figure 14.3 shows the unit components.

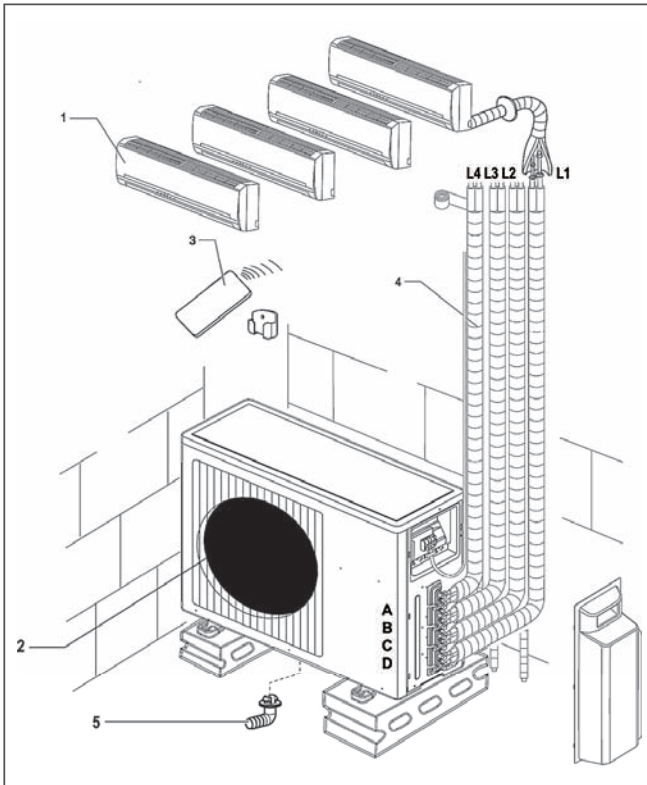

**Fig. 14.3 Unit components.**

**Legend**

- 1 Indoor Unit
- 2 Outdoor Unit
- 3 Remote controller and holder
- 4 Connections and channels
- 5 Condensed water drainage pipe

**14.2 Address setting for Cassette and Duct Indoor units by using Dip switches**

**Warning!** If this is not done properly, the unit will not work! Duct type of indoor units can only set the address by using the dip switch. Make sure before doing the address setting in the PCB switches that the system is powered off.

- 1) Please note that the address must be set as the following:  
 Indoor unit connected to valve A, the address must be 1  
 Indoor unit connected to valve B, the address must be 2  
 Indoor unit connected to valve C, the address must be 3  
 Indoor unit connected to valve D, the address must be 4
- 2) Address setting process when using the dip switches SW01 and SW03:  
 2.1 The dip switches SW01 and SW03 are on the Indo-

- or unit PCB
- 2.2 Before conducting the address setting process the system must be powered off
- 2.3 Access the indoor unit PCB

**Note!** In the case of Cassette indoors, first take out the panel and filters, take off the flaps and the front cover, disconnect the swing motor connectors from the PCB, and take out the lower part of the PCB.

- 2.4 Change the position of DIP 7 of SW01 from OFF to ON, following the table XY below.

**Warning!** If dip switch SW01 is not turned to ON, the address setting will not work.

- 2.5 In order to set the corresponding address from 1 to 4, please change the DIP 6 to 8 from SW03, following the table XY below.

SW01	SW03	INDOOR UNIT ADDRESS	OUTDOOR VALVE																																																																
<table border="1"> <tr><td>1</td><td>2</td><td>3</td><td>4</td><td>5</td><td>6</td><td>7</td><td>8</td></tr> <tr><td></td><td></td><td></td><td></td><td></td><td></td><td></td><td></td></tr> <tr><td></td><td></td><td></td><td></td><td></td><td></td><td></td><td></td></tr> <tr><td></td><td></td><td></td><td></td><td></td><td></td><td></td><td></td></tr> </table> ON/OFF	1	2	3	4	5	6	7	8																									<table border="1"> <tr><td>1</td><td>2</td><td>3</td><td>4</td><td>5</td><td>6</td><td>7</td><td>8</td></tr> <tr><td></td><td></td><td></td><td></td><td></td><td></td><td></td><td></td></tr> <tr><td></td><td></td><td></td><td></td><td></td><td></td><td></td><td></td></tr> <tr><td></td><td></td><td></td><td></td><td></td><td></td><td></td><td></td></tr> </table> ON/OFF	1	2	3	4	5	6	7	8																									1	A
1	2	3	4	5	6	7	8																																																												
1	2	3	4	5	6	7	8																																																												
	<table border="1"> <tr><td>1</td><td>2</td><td>3</td><td>4</td><td>5</td><td>6</td><td>7</td><td>8</td></tr> <tr><td></td><td></td><td></td><td></td><td></td><td></td><td></td><td></td></tr> <tr><td></td><td></td><td></td><td></td><td></td><td></td><td></td><td></td></tr> <tr><td></td><td></td><td></td><td></td><td></td><td></td><td></td><td></td></tr> </table> ON/OFF	1	2	3	4	5	6	7	8																									2	B																																
1	2	3	4	5	6	7	8																																																												
	<table border="1"> <tr><td>1</td><td>2</td><td>3</td><td>4</td><td>5</td><td>6</td><td>7</td><td>8</td></tr> <tr><td></td><td></td><td></td><td></td><td></td><td></td><td></td><td></td></tr> <tr><td></td><td></td><td></td><td></td><td></td><td></td><td></td><td></td></tr> <tr><td></td><td></td><td></td><td></td><td></td><td></td><td></td><td></td></tr> </table> ON/OFF	1	2	3	4	5	6	7	8																									3	C																																
1	2	3	4	5	6	7	8																																																												
	<table border="1"> <tr><td>1</td><td>2</td><td>3</td><td>4</td><td>5</td><td>6</td><td>7</td><td>8</td></tr> <tr><td></td><td></td><td></td><td></td><td></td><td></td><td></td><td></td></tr> <tr><td></td><td></td><td></td><td></td><td></td><td></td><td></td><td></td></tr> <tr><td></td><td></td><td></td><td></td><td></td><td></td><td></td><td></td></tr> </table> ON/OFF	1	2	3	4	5	6	7	8																									4	D																																
1	2	3	4	5	6	7	8																																																												

**14.3 Address setting for Wall units when using the dip switches**

**Warning!** If this is not done properly, the unit will not work! Make sure before doing the address setting in the PCB switches that the system is powered off.

- 1) Please note that the address must be set as the following:  
 Indoor unit connected to valve A, the address must be 1  
 Indoor unit connected to valve B, the address must be 2  
 Indoor unit connected to valve C, the address must be 3  
 Indoor unit connected to valve D, the address must be 4
- 2) Address setting process when using the dip switches SW01 and SW02:  
 2.1 The dip switches SW01 and SW02 are on the Indoor unit PCB  
 2.2 Before conducting the address setting process the system must be powered off.

## 14 Communication between the Indoor and Outdoor Units

2.3 Access the indoor unit PCB

2.4 Change the position of DIP 7 of SW01 from OFF to ON, following the table XY below.



### Warning!

If dip switch SW01 is not turned to ON, the address setting will not work.

2.5 In order to set the corresponding address from 1 to 4, please change the DIP 6 to 8 from SW02, following the table XY below.

SW01	SW02	INDOOR UNIT ADDRESS	OUTDOOR VALVE
		1	A
		2	B
		3	C
		4	D

### 14.4 Address setting for Wall Indoors V 10 by using the remote and the LCD display board

- Power all units.
- Put the indoor unit in "Stand By" mode by pressing the "OFF" button.
- For each unit, the following steps should be followed:
  - Press the emergency button for 15 seconds as shown in figure 13.1 and you will hear 4 beeps. Release the emergency button.
  - Switch on the indoor unit with the remote control by pressing the "ON" button. The LCD display board will display number "1". When the unit switches on, it automatically goes into direction setup mode.
  - To set the direction of the indoor unit, just press the "SLEEP" button. Depending on the number of times you press it, the setup will vary:
    - By pressing once, the direction is "1" and the LCD display board shows "1"
    - By pressing twice, the direction is "2" and the LCD display board shows "2"
    - By pressing three times, the direction is "3" and the LCD display board shows "3"
    - By pressing four times, the direction is "4" and the LCD display board shows "4"
- Switch off the unit using the "OFF" button and the direction will be set
- This process should be repeated for each indoor unit.

## 15 Preparation for Use

This consists of the following steps:

- Checking for Leaks.
- Purging the installation.
- Start up.
- Troubleshooting.

### 15.1 Checking for leaks

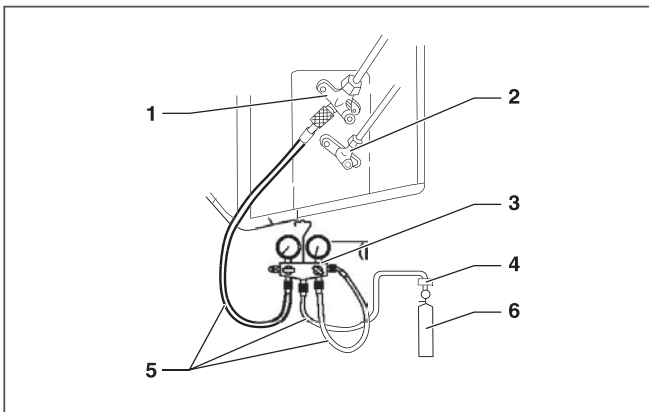

Fig. 15.1 Checking for leaks in the installation.

#### Legend

- 1 Suction valve (gas)
- 2 Return valve (liquid)
- 3 Combined meter
- 4 Non-return joint
- 5 Pipes for coolant
- 6 Nitrogen cylinder

- Connect a combined meter (faucets) to the three-way valve in the suction hose.
- Connect a nitrogen cylinder to the low-pressure end of the combined meter.
- Carefully open the valves corresponding to the faucets and pressurise the system.
  - In the event of using R-407C coolant set it to 28.5 bar(g) of pressure, for 10 min.
  - In the event of using R-410A coolant set it to 40 bar(g) of pressure, for 10/20 min.
- Check that all the connections and joints are watertight.
- Close all the valves on the combined meter and remove the nitrogen cylinder.
- Release the pressure from the system by slowly opening the faucets.
- In the event of detecting leaks, repair them and repeat the test.

According to Regulation 842/2006/EC, the complete refrigerant circuit must be periodically checked for leakage. Take the necessary actions to ensure these tests are performed and the results correctly logged into the maintenance record of the machine. The leakage test must be done with the following frequency:

- Systems with less than 3 kg of refrigerant => periodic leakage test not needed
- Systems with 3 kg or more of refrigerant => at least once every 12 months

- Systems with 30 kg or more of refrigerant => at least once every 6 months
- Systems with 300 kg or more of refrigerant => at least once every 3 months

### 15.2 Purging the Installation

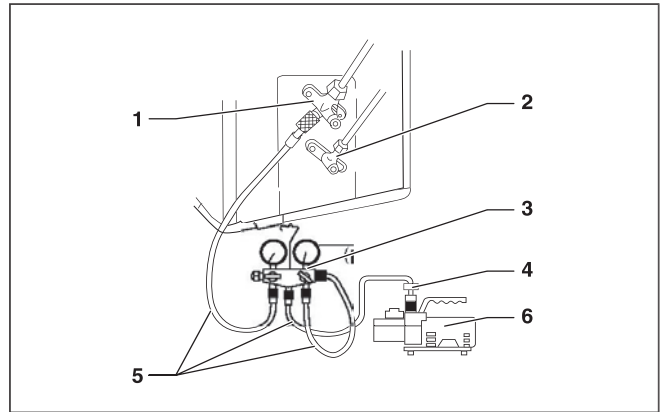

Fig. 15.2 Purging the installation.

#### Legend

- 1 Suction valve (gas)
- 2 Return valve (liquid)
- 3 Combined meter
- 4 Non-return joint
- 5 Pipes for coolant
- 6 Vacuum pump for coolant

- Connect a combined meter (faucets) to the three-way valve in the suction hose.
- Connect a vacuum pump to the low-pressure end of the combined meter.
- Ensure that the faucets are closed.
- Turn the vacuum pump on and open the vacuum valve, the low valve on the combined meter and the gas faucet.
- Ensure that the high valve is closed.
- Leave the vacuum pump functioning for approximately 15 minutes (depending on the size of the installation) to carry out the vacuum.
- Check the needle on the low pressure manometer: it should indicate -0.1 MPa (-76 cmHg).

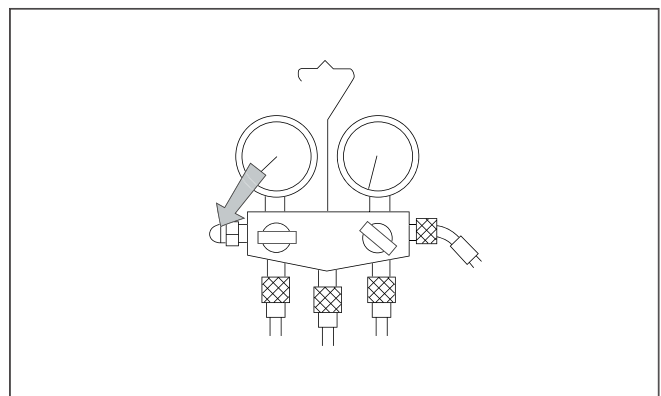
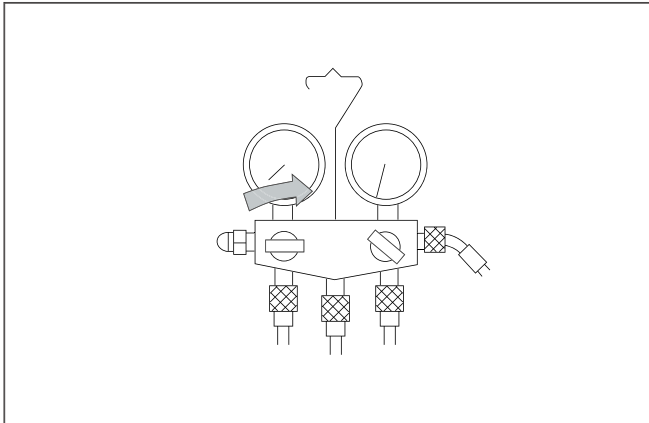

Fig. 15.3 Low pressure manometer reading with the low valve open.



## 15 Preparation for Use

- Close the low valve on the combined meter, disconnect the vacuum pump and close the vacuum valve.
- Check the manometer needle after approximately 10-15 minutes have elapsed: the pressure should not rise. If it does rise, there are leaks in the circuit: repair them (check the joints, joins, the indoor and outdoor parts and the technical service faucets).

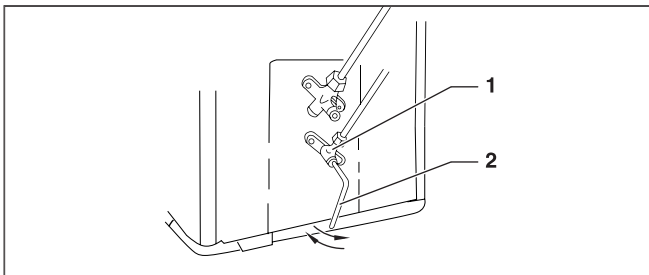

**Fig. 15.4 Low pressure manometer reading with the low valve closed: checking for leaks.**



**Warning!**  
Danger of malfunction and leaks.  
Ensure that the service valves are closed.

### 15.3 Start up

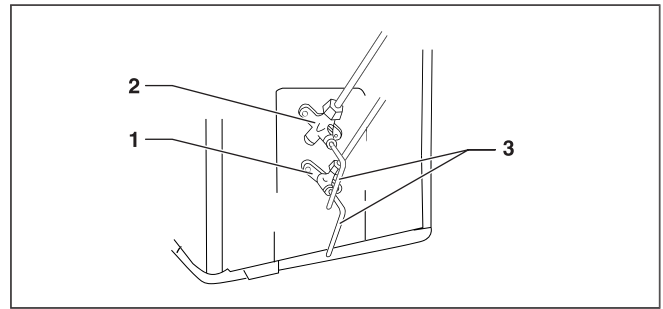

**Fig. 15.5 Filling the installation.**

#### Legend

- 1 Two-way valve
- 2 Actuation faucet

- Open the two-way valve by twisting the rod 90° anticlockwise and close it after 6 seconds. The installation will be filled with coolant.
- Check the installation again for tightness:
  - If there are leaks see section 15.4.
  - If there are no leaks, continue.
- Remove the combined meter with the joining hoses and faucets.
- Open the two and three-way valves by twisting the rod anticlockwise as far as it will go.

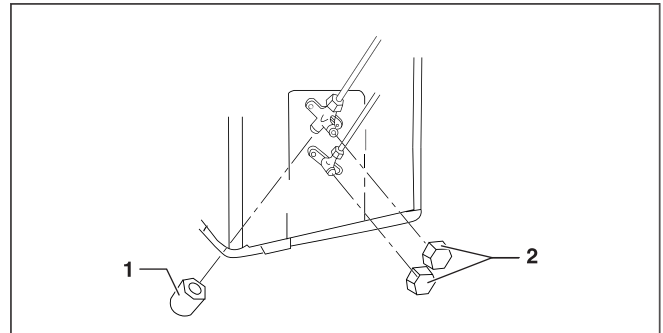

**Fig. 15.6 Opening of the two and three-way valves.**

#### Legend

- 1 Two-way valve
- 2 Three-way valve
- 3 Actuation faucets

- Cover the two and three-way valves with the corresponding protective covers.



**Fig. 14.7 Protective covers.**

#### Legend

- 1 Service hole lid
- 2 Two and three-way valve covers

- Connect the unit and run it for a few moments checking that it carries out its functions correctly (for more information see the user manual).

### 15.4 Troubleshooting

If the event of a gas leak, proceed as follows:

- Purge the installation removing the coolant by pumping.
  - You need a suction pump and a recycling bottle.



**Warning!**  
Never dump coolant into the environment!  
Coolant is a harmful product for the environment.

- Check the flaring joints.
- Repair the leak, replace indoor and outdoor parts which are not tight.
- Fill the unit with the correct amount of coolant using coolant scales.
- Proceed to check for leakage as described above.

## 16 Error Codes

### 16.1 Cassette units

Trouble Shooting	Failure Code (Timer Led of Indoor Receiver Board Flashes Times)	Possible Reasons
Faulty temperature sensor Tai	Once*	Sensor disconnected, or broken, or at wrong position, or short circuit
Faulty temperature sensor Tc1	Twice*	Sensor disconnected, or broken, or at wrong position, or short circuit
Faulty temperature sensor Tc2	3 Times*	Sensor disconnected, or broken, or at wrong position, or short circuit
Faulty temperature sensor Tm	4 Times*	Sensor disconnected, or broken, or at wrong position, or short circuit
Faulty EEPROM on indoor unit PCB	5 Times*	Faulty indoor unit PCB
Abnormal communication between indoor and outdoor unit	6 Times*	Wrong connection, or the wires be disconnected, or wrong address setting of indoor units, or faulty power supply or faulty PCB
Abnormal communication between wired controller and indoor unit PCB	7 Times*	Wrong connection, or use the wired controller be disconnected, faulty PCB
Drainage System abnormal	8 Times*	Pump motor disconnected, or at wrong position, or the float switch broken down, or the float switch disconnected, or at wrong position
Indoor Unit address repeated	9 Times*	Wrong setting of indoor unit address
Abnormal communication between chip TMP/807 and chip TMP/846	14 Times*	Faulty indoor unit PCB
Malfunction on outdoor unit	20 Times*	Check the outdoor unit failure code

 **Note!**

1. Please contact the installer or distributors when trouble happens to repair it.

2. Turn the power off and power on again, if the failure code recurs, please inform the franchiser.

3. Failure codes marked with \* are resumable.

## 16 Error Codes

### 16.2 Duct units

Trouble Shooting (indoor unit)	Failure Code (Check the wired remote controller)	Possible Reasons
Faulty temperature sensor <b>Tai</b>	01 *	Sensor disconnected, or broken, or at wrong position, or short circuit
Faulty temperature sensor <b>Tc1</b>	02 *	Sensor disconnected, or broken, or at wrong position, or short circuit
Faulty temperature sensor <b>Tc2</b>	03 *	Sensor disconnected, or broken, or at wrong position, or short circuit
Faulty temperature sensor <b>Tm</b>	04 *	Sensor disconnected, or broken, or at wrong position, or short circuit
Faulty EEPROM on indoor unit PCB	05	Faulty indoor unit PCB
Abnormal communication between indoor and outdoor unit	06 *	Wrong connection, or the wires be disconnected, or wrong address setting of indoor units, or faulty power supply or faulty PCB
Abnormal communication between wired controller and indoor unit PCB	07 *	Wrong connection, or use the wired controller be disconnected, faulty PCB
Drainage System abnormal	08 *	Pump motor disconnected, or at wrong position, or the float switch broken down, or the float switch disconnected, or at wrong position
Indoor Unit address repeated	09	Wrong setting of indoor unit address
Abnormal communication between chip TMP/807 and chip TMP/846	0E	Faulty indoor unit PCB
Trouble Shooting (outdoor unit)	Failure Code (Check the wired remote controller)	Possible Reasons
Faulty defrost sensor <b>Te</b>	14 *	Sensor disconnected, or broken, or short circuit
Faulty sensor <b>Tao</b>	15 *	Sensor disconnected, or broken, or short circuit
Faulty sensor <b>Ts</b>	16 *	Sensor disconnected, or broken, or short circuit
Faulty sensor <b>Td</b>	17 *	Sensor disconnected, or broken, or short circuit
Input overcurrent	19	Over current of the system, or broken of the current sensor, or malfunction with indoor or outdoor fan motors, or faulty PCB.
System high pressure protection	1E*	High pressure switch is disconnected, or high pressure switch worked, or Tc too high and faulty outdoor fan motor when cooling, or faulty indoor fan motors when heating, or refrigerant overabundance

Trouble Shooting (indoor unit)	Failure Code (Check the wired remote controller)	Possible Reasons
System low pressure protection	1F*	Low pressure switch is disconnected, or low pressure switch worked, or Te too low and faulty outdoor fan motors when heating, or faulty indoor fan motor when cooling, or refrigerant shortage
IPM protection	20	IPM over current, or short circuit, or IPM temperature too high, or IPM input voltage too low, or faulty SPDU(or ISPM).
EEPROM fault	21	Faulty outdoor unit PCB
Over hot protection of compressor	22	Serious lack of refrigerant of the system, or the ambient temperature too high, or PMVs be blocked
Over hot protection of SPDU (or ISPM)	23	Ambient temperature too high, or outdoor fan be blocked, or bad air circulation of outdoor unit
DC fan motor fault	24	Fan is blocked, or the terminal is disconnected from the PCB
Faulty 4-way valve switching on	25	Coil of 4-way valve is disconnected, or faulty outdoor PCB
Faulty sensor Tc	26 *	Sensor disconnected, or broken, or short circuit
Faulty sensor Toci	2A*	Sensor disconnected, or broken, or short circuit
Low voltage protection	2C	VDC<194V, too low voltage from power source
High voltage protection	2D	VDC>400V, too high voltage from power source
Abnormal communication between main PCB and SPDU(or ISPM)	2E	Communication cables broken, or not be well connected, or faulty main PCB, or faulty SPDU (or ISPM)
Compressor be locked	32	Faulty compressor or SPDU(or ISPM)
Compressor vibration too big	33	Faulty compressor
Compressor lose position	34	Faulty SPDU(or ISPM)
Faulty compressor start	35	Faulty compressor or SPDU(or ISPM)
Faulty position checking circuit	37	Faulty SPDU(or ISPM)
Compressor broken	38	Faulty compressor or SPDU(or ISPM)

## 16 Error Codes



### Note!

1. Please contact the installers or distributors when trouble happens to repair it.

2. Turn the power off and power on again, if the failure code recurs, please inform the franchiser.

3. Failure codes marked with \* are resumable.

### 16.3 Wall units

Trouble Shooting	Failure Code (Displayed on LCD)	Possible Reasons
Faulty temperature sensor Tai	1*	Sensor disconnected, or broken, or at wrong position, or short circuit
Faulty temperature sensor Tc1	2*	Sensor disconnected, or broken, or at wrong position, or short circuit
Faulty temperature sensor Tc2	3*	Sensor disconnected, or broken, or at wrong position, or short circuit
Faulty temperature sensor Tm	4*	Sensor disconnected, or broken, or at wrong position, or short circuit
Faulty EEPROM on indoor unit PCB	5	Faulty indoor unit PCB
Abnormal communication between indoor and outdoor unit	6*	Wrong connection, or the wires be disconnected, or wrong address setting of indoor units, or faulty PCB, or faulty power supply
Indoor unit address repeated	9	Wrong setting of indoor unit address
Faulty indoor unit fan motor	11	Fan is blocked, or the terminal is disconnected from the PCB, or faulty indoor unit PCB
Faulty driver of indoor unit fan motor	12	Faulty indoor unit PCB
Abnormal communication between chip TMP/807 and chip TMP/846	14*	Faulty indoor unit PCB
Malfunction on outdoor unit	20	Check the outdoor unit



### Note!

1. Please contact the installers or distributors when trouble happens to repair it.

2. Turn the power off and power on again, if the failure code recurs, please inform the franchiser.

3. Failure codes marked with \* are resumable.

## 16.4 Outdoor units

Failure Code	State of LED 5-4-3-2-1	Trouble Shooting	Possible Reasons
1	○○○○●	Faulty defrost sensor Te	Sensor disconnected, or broken, or short circuit
2	○○○●○	Faulty defrost sensor Tao	Sensor disconnected, or broken, or short circuit
3	○○○●●	Faulty defrost sensor Ts	Sensor disconnected, or broken, or short circuit
4	○○●○○	Faulty sensor Td	Sensor disconnected, or broken, or short circuit
5	○○●○○	Input Overcurrent	Over current of the system, or broken of the current sensor, or malfunction with indoor or outdoor fan motors, or faulty PCB
6	○○●●○	Abnormal communication between indoor and outdoor units	Wrong connection, or the wires be disconnected or wrong address setting of indoor units, or faulty PCB, or faulty power supply
9	○●○○●	System high pressure protection	High pressure switch is disconnected, or high pressure switch worked, or Tc too high and faulty indoor fan motors when heating, or refrigerant over-abundance
10	○●○○○	System low pressure protection	Low pressure switch is disconnected, or low pressure switch worked, or Te too low and faulty outdoor fan motors when heating, or faulty indoor fan motor when cooling, or refrigerant shortage.
11	○●○○●	IPM protection	IPM over current, or short circuit, or IPM temperature too high, or IPM input voltage too low, or faulty SPDU (or ISPM).
12	○●●○○	EEPROM fault	Faulty outdoor unit PCB
13	○●●○○	Over hot protection of compressor	Serious lack of refrigerant of the system, or the ambient temperature too high, or PMVs be blocked
14	○●●○○	Over hot protection of SPDU (or ISPM)	Ambient temperature too high, or outdoor fan be blocked, or bad air circulation of outdoor unit
15	○●●●●	DC fan motor fault	Fan is blocked, or the terminal is disconnected from the PCB
16	●○○○○	Faulty 4-way valve switching on	Coil of 4-way valve is disconnected, or faulty outdoor PCB
17	●○○○●	Faulty sensor Tc	Sensor disconnected, or broken, or short circuit
21	●○○○●	Faulty sensor Toci	Sensor disconnected, or broken, or short circuit
23	●○○●●	Low voltage protection	VDC<194V, too low voltage from power source

## 16 Error Codes

Failure Code	State of LED 5-4-3-2-1	Trouble Shooting	Possible Reasons
24	●●○○○	High voltage protection	VDC>400V, too high voltage from power source
25	●●○○●	Abnormal communication between main PCB and SPDU (or ISPM)	Communication cables broken, or not be well connected, or faulty main PCB, or faulty SPDU (or ISPM)
26	●●○○○	Compressor be locked	Faulty compressor or SPDU (or ISPM)
27	●●○○●	Compressor vibration too big	Faulty compressor
28	●●○○○	Compressor lose position	Faulty SPDU (or ISPM)
29	●●○○●	Faulty compressor start	Faulty compressor or SPDU (or ISPM)
30	●●●○○	Faulty position checking circuit	Faulty SPDU (or ISPM)
31	●●●●●	Compressor broken	Faulty compressor or SPDU (or ISPM)



### Note!

Take off the plastic cover on the left side of the unit, you can find the LEDs near the communication terminal.

Symbol ● means the LED is ON.

Symbol ○ means the LED is OFF.





