

For the expert technician

Installation manual
auroTHERM



On-roof/flat roof installation

VTK 570/2
VTK 1140/2

Contents

Contents

1	Notes on the documentation.....	3	10	Technical data.....	39
1.1	Other applicable documents	3			
1.2	Storage of the documents.....	3			
1.3	Symbols used	3			
1.4	Applicability of the manual.....	3			
2	Intended use	3			
2.1	Combination with other components	3			
2.2	Operational conditions	3			
3	Safety instructions	4			
3.1	Technical Guidance.....	4			
3.2	Related documents.....	4			
3.3	Regulations for the prevention of accidents ...	4			
3.4	Lightning protection.....	5			
3.5	Frost protection.....	5			
4	Before installation	5			
4.1	Safety instructions.....	5			
4.2	Scope of delivery	6			
4.2.1	On-roof mounting	6			
4.2.2	Flat-roof mounting.....	7			
4.3	Assembling the collector array	8			
4.3.1	On-roof mounting	8			
4.3.1.1	Collector arrangement, 1-row	8			
4.3.1.2	Collector arrangement, 2-row	10			
4.3.1.3	Collector arrangement, 3-row	11			
4.3.2	Flat-roof mounting.....	13			
4.4	Interconnection scheme.....	14			
4.5	Preparing the hydraulic connection.....	16			
4.5.1	On-roof mounting	16			
4.5.2	Flat-roof mounting.....	16			
4.6	Required tools.....	16			
5	On-roof mounting.....	16			
5.1	Fitting the brackets	17			
5.2.1	Bracket Type P (pantile)	19			
	Fixing to the roof batten	20			
5.2.2	Bracket Type S (for high profile pantiles)	21			
5.2.3	Bracket Type S (Low profile for slate/ flat tiles)	21			
5.2.3	Hanger bolt fixing kit	22			
5.3	Fitting the collectors	23			
6	Flat-roof mounting	28			
6.2	Weighting and arrangement of the frames... ..	28			
6.3	Fitting the collectors.....	32			
7	Final operations	37			
8	Recycling and disposal.....	38			
9	Vaillant Customer Service and warranty .	38			
9.1	Vaillant warranty.....	38			
9.2	Vaillant service	38			

1 Notes on the documentation

The instructions below are intended to help you throughout the entire documentation.

1.1 Other applicable documents

When assembling the tube collectors, pay attention to all the installation instructions for the components and assemblies within the solar installation. These instructions are included with the individual components of the system and the additional components. **We accept no liability for any damage caused by failure to observe these instructions.**

1.2 Storage of the documents

Please pass on this installation manual and all other applicable documents and auxiliary equipment to the plant operator, whose responsibility it is to ensure the manuals and auxiliary equipment are available whenever required.

1.3 Symbols used

Please observe the safety instructions in this installation manual for the installation of the collector!



Danger!
Immediate risk of serious injury or death!



Danger!
Risk of death from electric shock!



Danger!
Danger of burning and scalding!



Caution!
Potentially dangerous situations for the product and the environment!



Note
Useful information and instructions.

- Symbol indicating the required action

1.4 Applicability of the manual

This installation manual applies exclusively to tube collectors with the following part numbers:

Collector type	Part number
VTK 570/2	0010002227
VTK 1140/2	0010002228

Table 1.1 Collector types and article numbers

Please see the identification plate on the upper edge of the collector for the part number of the tube collector.

2 Intended use

Vaillant auroTHERM tube collectors are built according to the state of the art and recognised safety rules and regulations.

Nevertheless, improper use may cause danger to life and limb of the user or third parties and could impair the operation of the unit and other objects.

The unit is not intended for use by persons (including children) with reduced physical, sensory or mental capabilities, or lack of experience and/or knowledge, unless they have been given supervision or instruction concerning use of the unit by a person responsible for their safety.

Children must be watched to ensure that they do not play with the unit.

Vaillant auroTHERM tube collectors are used for solar assisted hot water generation and where specially designed can provide additional heating such as pool heating.

The collectors may only be operated with Vaillant ready-mixed solar fluid. Passing heating water or hot water directly through the collectors is not permitted.

Any other use or use exceeding the above-mentioned applications shall be considered as improper use. The manufacturer/supplier shall not be responsible for any damages resulting from such improper use. The user alone bears the risk.

Intended use includes observance of the operating and installation manuals and all other applicable documents, as well as adherence to the maintenance and inspection conditions.



Caution!
Any improper use is forbidden!

2.1 Combination with other components

Vaillant tube collectors should be combined only with Vaillant components (fixing, connections) and system components.

The use of other components or system components shall be considered as improper use. We accept no liability.

2.2 Operational conditions



Caution!
The roof may collapse!
Mount the tube collectors only on roofs with an adequate load-bearing capacity.
If necessary, call a technician.

2 Intended use

3 Safety instructions

On-roof mounting:

The tube collectors can be mounted at an angle of 15° - 75°. An installation angle of less than 15° is not permissible.

Flat roof installation:

The tube collectors can be installed on flat roof frames in the as-delivered condition with an angle of 30°, 45° or 60°. An installation angle of less than 15° is not permissible.

3 Safety instructions

The following safety instructions, technical rules and accident prevention regulations must be observed when installing the flat collectors.



Danger!
Risk of death from falls and falling objects!
Observe the national regulations for working at heights.



Danger!
Danger of burning and scalding!
In case of solar irradiation inside the units, collectors can reach 300 °C. Remove the sun protection film installed at the factory only after the solar energy system has been started up.



Danger!
Danger of burning and scalding!
In case of solar irradiation inside the units, collectors can reach 300 °C.
Do not perform maintenance work under direct sunlight.



Caution!
Collector damage!
A qualified engineer is required to install tube collectors in accordance with this installation manual.
The installation should thus be performed only if a qualified engineer is available.

3.1 Technical Guidance

The system must be installed in accordance with all relevant and applicable national regulations, and must be installed to suit site conditions.

Observe all national regulations, including:

- Working at Heights Regulations 2005
- Health and Safety at Work Act 1974
- Electricity at Work Regulations 1989
- IEE Wiring Regulations BS 7671
- Lightning protection requirements
- Equipotential bonding of electrical installations.

3.2 Related documents

Designers and installers should refer to current information and standards. A useful reference would be the energy saving trust document CE 131 (this is downloadable from their web site at www.est.org.uk/housingbuildings) which lists relevant standards and other documents that you might refer to. This includes but is not limited to the following;

Solar Standards

BS 7431, BS 6785: 1986, BS EN 12975 / 6 (Pt1-2), prEN 12977 (1-2-3) BS EN ISO 9488

The installation of the solar system must be in accordance with the relevant requirements of Health and Safety Document No. 635 (The Electricity at Work Regulations 1989), BS7671 (IEE Wiring Regulations) and the Water Supply (Water Fitting) Regulations 1999, or The Water Bylaws 2000 (Scotland). It should also be in accordance with the relevant requirements of the Local Authority, Building Regulations, The Building Regulations (Scotland), The Building Regulations (Northern Ireland) and the relevant recommendations of the following British Standards:

- BS EN 806: Specification for installations inside buildings conveying water for human consumption
- BS 6700: Services supplying water for domestic use within buildings and their curtilages.
- BS. 5449 Forced circulation hot water central heating systems for domestic premises.
Note: only up to 45 kW.
- BS. 6880 Low temperature hot water heating systems of output greater than 45 kW.
Part 1 Fundamental and design considerations.
Part 2 Selection of equipment.
Part 3 Installation, commissioning and maintenance.
- BS 6114: Expansion vessels using an internal diaphragm for unvented hot water supply systems
- BS. 4814 Specification for: Expansion vessels using an internal diaphragm, for sealed hot water heating systems.

Unvented hot water systems must comply with building regulation G section 3.

3.3 Regulations for the prevention of accidents

When carrying out works such as solar installation work it is necessary to do so in a safe and workman like manner, taking due care of any aspects of the works that could result in injuries to person in or about the building as well as workers, passers by and the general public at large. To that end these works must conform, but not be limited to, the current regulations in force such as the following

- Health and Safety at Work act 1974
- Work at Height Regulations 2005.
- Electricity at Work Regulations 1989
- All necessary Building Regulations.

Work should be preceded by a risk assessment covering all aspects of health and safety risks, or training requirements that can reasonably be foreseen to be

associated with the work. All scaffolding in the UK, other than prefabricated (zip-up) scaffold towers, must be designed and constructed by a vetted contractor, and have suitable kick boards, hand rails and where appropriate netting. Areas around the scaffolding should be zoned off and marked with suitable warning signs to a suitable distance to protect persons from falling objects. Workers should have available and use personal protective equipment as necessary. This would include equipment such as fall protection systems, safety gloves, goggles, dust masks as well as any specialised equipment that may be in use such as lifting and handling equipment.

The completed works shall comply with all necessary BS EN Standards and Codes of practice as well as Building control or planning requirements and be confirmed where necessary by notification to building control or the appropriate competence based notification body.

3.4 Lightning protection



Caution!

Damage from lightning!

If the installation height is more than 20 m or if the collectors are projected above the roof ridge, electro-conductive components must be connected to a lightning protection device!

3.5 Frost protection



Caution!

Damage due to frost!

Never fill or flush the collector with water. Only fill and flush the collector with Vaillant ready-mixed solar fluid.
Check the solar fluid regularly with an anti-freeze tester.

4 Before installation

4.1 Safety instructions

Please note the following instructions before and during installation:



Danger!

Risk of death from falls and falling objects!

Observe the national regulations for working at heights.

Wear the Vaillant safety belt (article number 302066).



Danger!

Danger of burning and scalding!

In case of solar irradiation inside the units, collectors can reach 300 °C. Remove the sun protection film installed at the factory only after the solar energy system has been started up.



Caution!

Collectors may be damaged by incorrect storage!

Always store the collectors in a dry place and protected from the elements.

Caution!

System error function due to air bubbles!

To fill the system, use the fill trolley (article number 0020042548) to avoid air bubbles.

Use the manual air vent installed on the collector field.

Alternatively, install the Vaillant Solar automatic air vent (article number 302019) in the highest point of the system or the automatic de-aerator (article number 302418) in the solar circuit.

Observe the relevant installation and operating manual.

4 Before installation

4.2 Scope of delivery

- Check the mounting kit for completeness based on the illustrations and bills of materials.

4.2.1 On-roof mounting

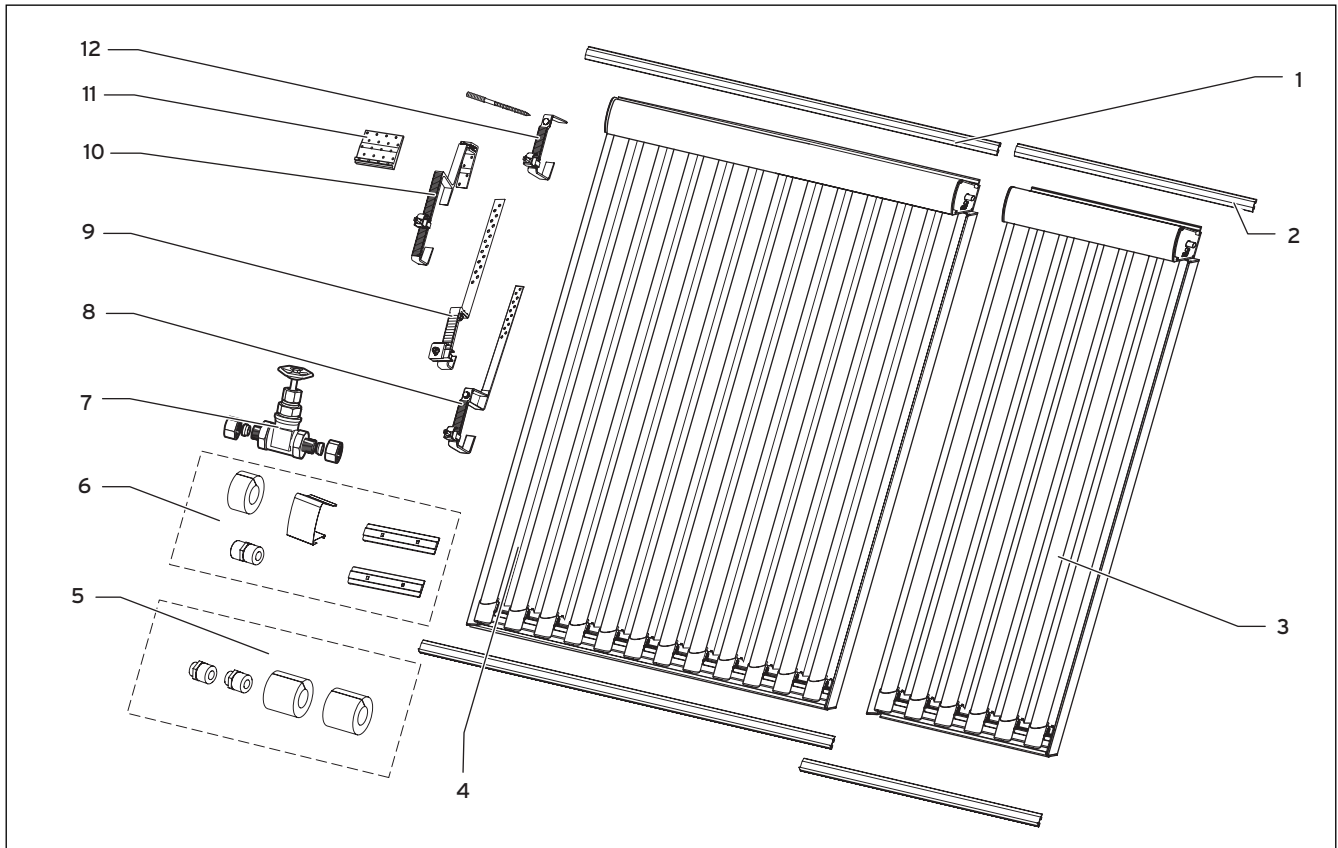

Fig. 4.1 On-roof mounting kit

Pos.	Description	Quantity	Article number (kit)
1	Rail kit VTK 1140/2	2	0020076781
2	Rail kit VTK 570/2	2	0020076780
3	Tube collector VTK 570/2	1	0010002227
4	Tube collector VTK1140/2	1	0010002228
5	Connecting kit VTK (basic module) - Compression fitting 15 mm x 3/4" external thread DN16 - Insulation EPDM 13 x 28, 60 mm, split	1	0020076785
6	Connecting kit VTK (expansion module) - Rail joining pieces - Double nipple 15 x 15 mm - Insulation Armeflex HT, 25 x 20 mm, 45lg - Cover clip	1	0020076779
7	Valve, 2-way VTK for parallel interconnection	1	0020076784
8	Bracket type S	4	0020067275 (for mounting side-by-side) 0020067276 (for mounting on top of one another)
9	Bracket type S flat	4	0020080145 (for mounting side-by-side) 0020080147 (for mounting on top of one another)
10	Bracket type P (for pantile)	4	0020067273 (for mounting side-by-side) 0020067274 (for mounting on top of one another)
11	Long base (accessory, not available in every country)	4	0020080177
12	Stair bolt mounting kit	4	0020067277

Table 4.1 On-roof mounting bill of materials

4.2.2 Flat-roof mounting

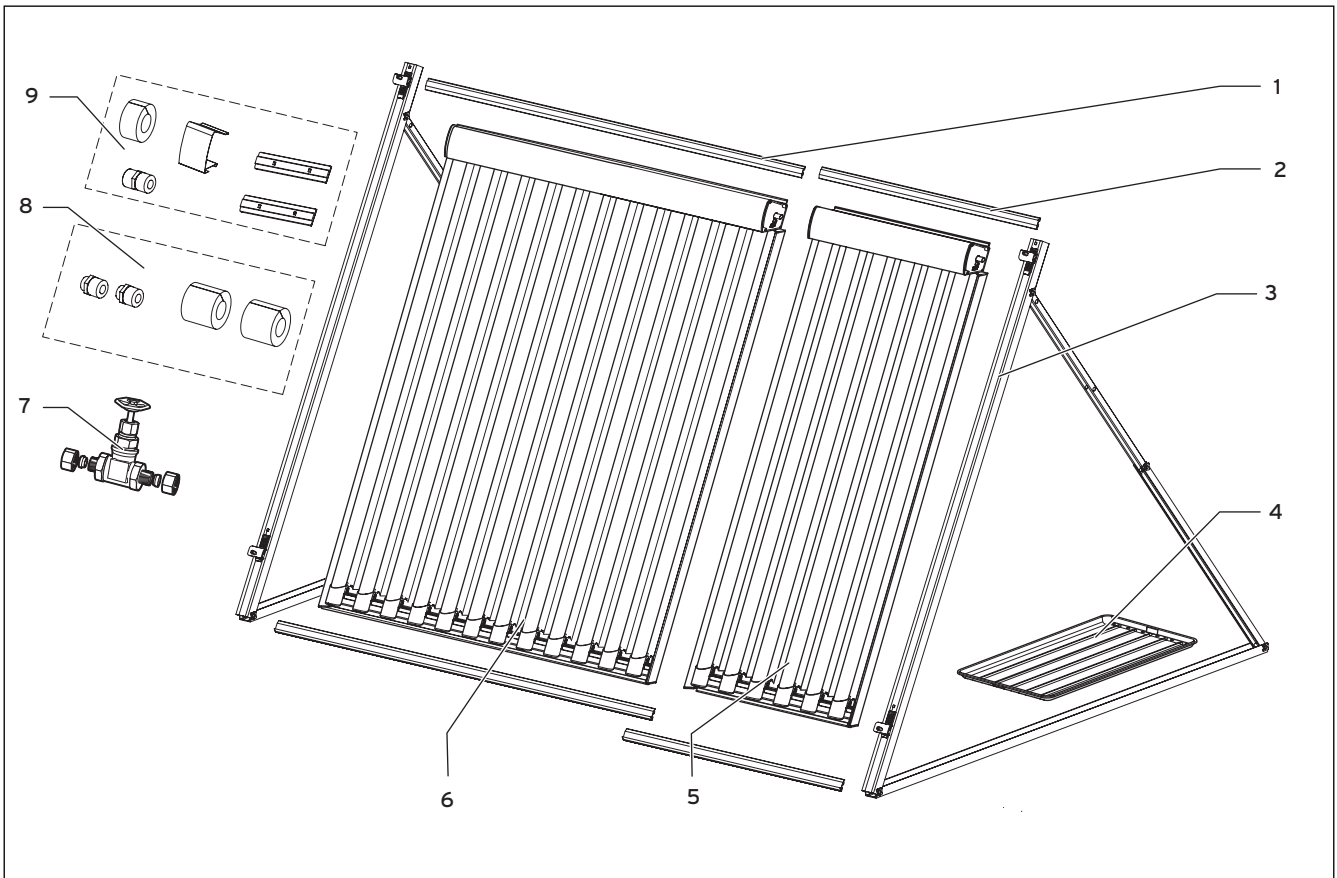

Fig. 4.2 Flat roof mounting kit

Pos.	Description	Quantity	Article number (kit)
1	Rail kit VTK 1140/2	2	0020076781
2	Rail kit VTK 570/2	2	0020076780
3	Open air installation, VTK	1	0020076778
4	Gravel tray kit	2 3	0020059904 (2 pcs.) 0020059905 (3 pcs.)
5	Tube collector VTK 570/2	1	0010002227
6	Tube collector VTK1140/2	1	0010002228
7	Valve, 2-way VTK for parallel interconnection	1	0020076784
8	Connecting kit VTK (basic module)	1	0020076785
9	Connecting kit VTK (expansion module)	1	0020076779

Table 4.2 Flat roof installation bill of materials

4 Before installation

4.3 Assembling the collector array

The following tables list the required components according to the type of installation.

4.3.1 On-roof mounting

When mounted on the roof, Vaillant tube collectors can be arranged above one another in up to 3 rows.

4.3.1.1 Collector arrangement, 1-row

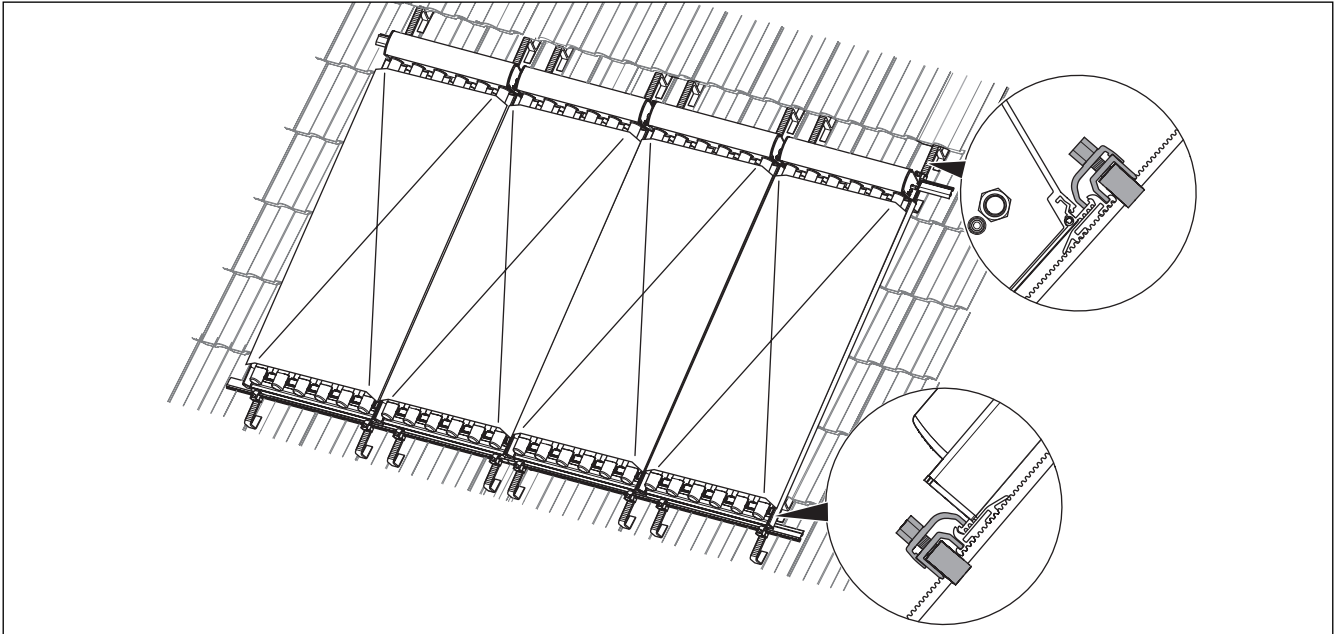

Fig. 4.3 Installation kit for single row on-roof mounting
(here: VTK 570/2)

		Number of collectors													
		1	2	3	4	5	6	7	8	9	10	11	12	13	14
VTK 570/2	Connecting kit VTK (basic module) Part No. 0020076785	1 ¹⁾													
	Connecting kit VTK (expansion module) Part No. 0020076779	-	1	2	3	4	5	6	7	8	9	10	11	12	13
	Bracket kit Type P (pantile) Part No. 0020067273	Required quantity													
	Bracket kit Type S (shingle) Part No. 0020067275														
	Bracket kit Type S flat Part No. 0020080145														
	Bracket kit (hanger bolt) Part No. 0020067277														
	Rail kit (2), VTK 570/2 Part No. 0020076780	1 ²⁾	2 ²⁾	3 ²⁾	4 ²⁾	5 ²⁾	6 ²⁾	7 ²⁾	8 ²⁾	9 ²⁾	10 ²⁾	11 ²⁾	12 ²⁾	13 ²⁾	14 ²⁾
		1	2	3	4	5	6	7	8	9	10	11	12	13	14
1) 1 each per row 2) applies up to 700 m above sea level															

Table 4.3 Components for single row on-roof mounting

Number of collectors		1	2	3	4	5	6	7	
VTK 1140/2	Connecting kit VTK (basic module) Part No. 0020076785	1 ¹⁾							
	Connecting kit VTK (expansion module) Part No. 0020076779	-	1	2	3	4	5	6	
	Bracket kit Type P (pantile) Part No. 0020067273	Required quantity	1 ²⁾	2 ²⁾	3 ²⁾	4 ²⁾	5 ²⁾	6 ²⁾	7 ²⁾
	Bracket kit Type S Part No. 0020067275								
	Bracket kit Type S flat Part No. 0020080145								
	Bracket kit (hanger bolt) Part No. 0020067277								
	Rail kit (2), VTK 1140/2 Part No. 0020076781	1	2	3	4	5	6	7	
Number of collectors VTK 1140/2			1	2	3	4	5	6	
Number of collectors VTK 570/2			1	1	1	1	1	1	
VTK 1140/2 + VTK 570/2	Connecting kit VTK (basic module) Part No. 0020076785	1 ¹⁾							
	Connecting kit VTK (expansion module) Part No. 0020076779		1	2	3	4	5	6	
	Bracket kit Type P (pantile) Part No. 0020067273	Required quantity	2 ²⁾	3 ²⁾	4 ²⁾	5 ²⁾	6 ²⁾	7 ²⁾	
	Bracket kit Type S Part No. 0020067275								
	Bracket kit Type S flat Part No. 0020080145								
	Bracket kit (hanger bolt) Part No. 0020067277								
	Rail kit (2), VTK 1140/2 Part No. 0020076781		1	2	3	4	5	6	
	Rail kit (2), VTK 570/2 Part No. 0020076780		1						
1) 1 each per row									
2) applies up to 700 m above sea level									

Table 4.3 Components for single row on-roof mounting (continued)

4 Before installation

4.3.1.2 Collector arrangement, 2-row

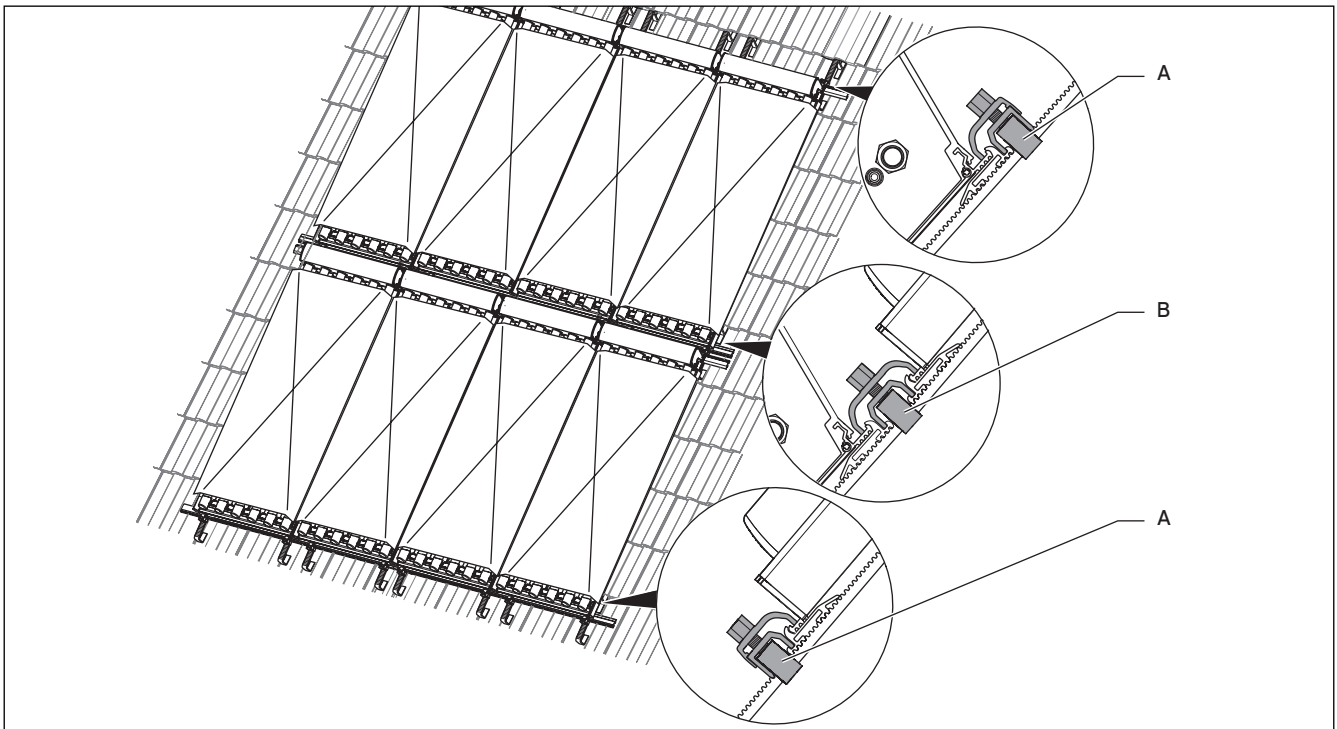

Fig. 4.4 Installation kit for 2-row on-roof mounting
(here: VTK 570/2)

Number of collectors per row				1	2	3	4	5	6	7	8	9	10	11	12	13	14	
				Number of rows														
VTK 570/2	Connecting kit VTK (basic module) Part No. 0020076785			2 ¹⁾														
	Connecting kit VTK (expansion module) Part No. 0020076779			-	2	4	6	8	10	12	14	16	18	20	22	24	26	
	Bracket kit Type P (pantile) Part No. 0020067273		a	1 ²⁾	2 ²⁾	3 ²⁾	4 ²⁾	5 ²⁾	6 ²⁾	7 ²⁾	8 ²⁾	9 ²⁾	10 ²⁾	11 ²⁾	12 ²⁾	13 ²⁾	14 ²⁾	
	Bracket kit Type S Part No. 0020067275																	
	Bracket kit Type S flat Part No. 0020080145																	
	Bracket kit Type P (pantile) Part No. 0020067274		B	1 ²⁾	2 ²⁾	3 ²⁾	4 ²⁾	5 ²⁾	6 ²⁾	7 ²⁾	8 ²⁾	9 ²⁾	10 ²⁾	11 ²⁾	12 ²⁾	13 ²⁾	14 ²⁾	
	Bracket kit Type S Part No. 0020067276																	
	Bracket kit Type S flat Part No. 0020080147																	
Rail kit (2), VTK 570/2 Part No. 0020076780			2	4	6	8	10	12	14	16	18	20	22	24	26	28		

1) when the connection between the rows is also flat-sealing

2) applies up to 700 m above sea level

Table 4.4 Components for 2-row on-roof mounting

			1	2	3	4	5	6	7	
Number of collectors per row										
Number of rows			2							
VTK 1140/2	Connecting kit VTK (basic module) Part No. 0020076785		2 ¹⁾							
	Connecting kit VTK (expansion module) Part No. 0020076779		-	2	4	6	8	10	12	
	Bracket kit Type P (pantile) Part No. 0020067273		a	1 ²⁾	2 ²⁾	3 ²⁾	4 ²⁾	5 ²⁾	6 ²⁾	7 ²⁾
	Bracket kit Type S Part No. 0020067275									
	Bracket kit Type S flat Part No. 0020080145									
	Bracket kit, Type P (pantile) Part No. 0020067274		B	1 ²⁾	2 ²⁾	3 ²⁾	4 ²⁾	5 ²⁾	6 ²⁾	7 ²⁾
	Bracket kit Type S Part No. 0020067276									
	Bracket kit Type S flat Part No. 0020080147									
Rail kit (2), VTK 1140/2, Part No. 0020076781			2	4	6	8	10	12	14	

1) when the connection between the rows is also flat-sealing
2) applies up to 700 m above sea level

Table 4.4 Components for 2-row on-roof mounting (continued)

4.3.1.3 Collector arrangement, 3-row

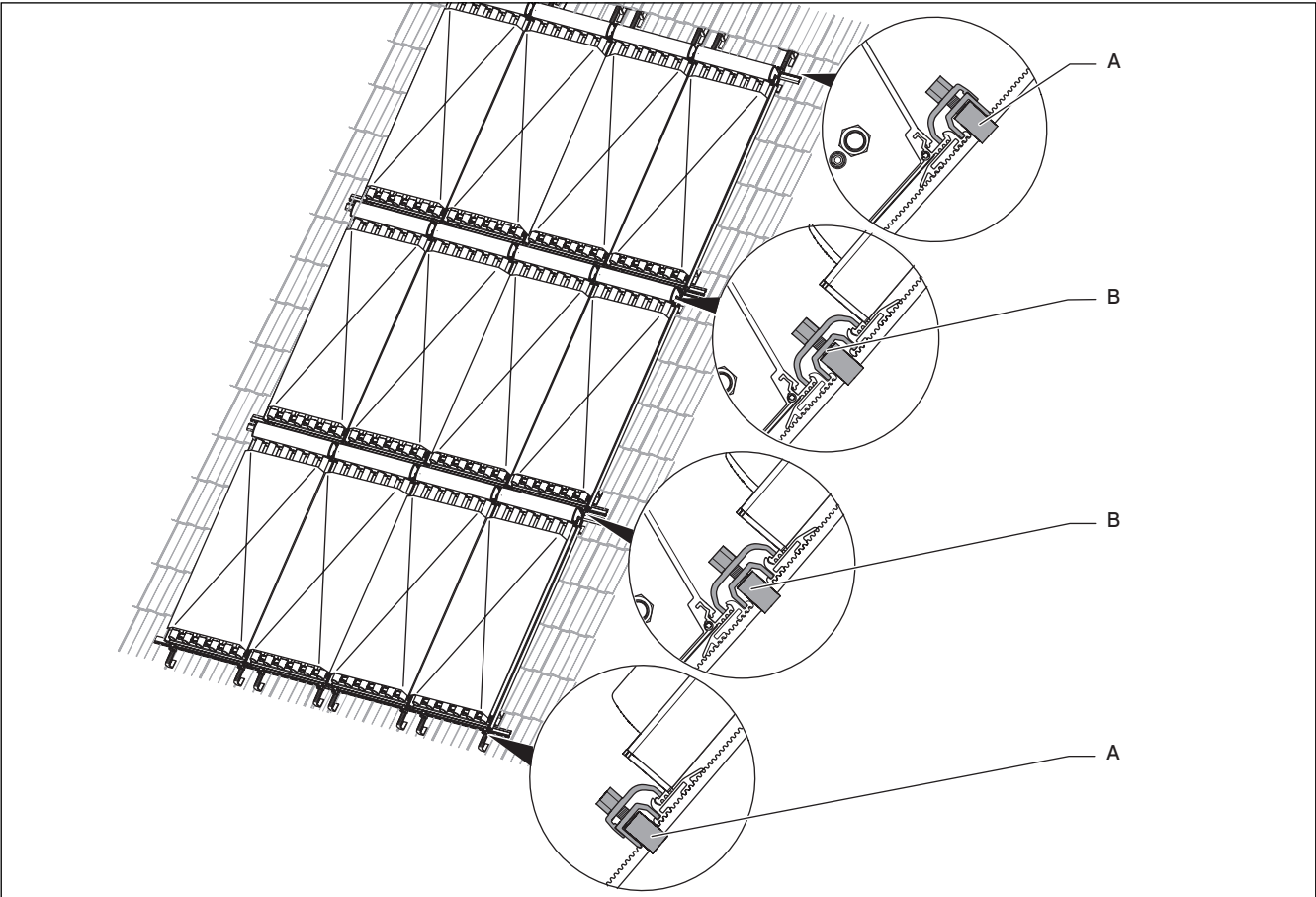

Fig. 4.5 Installation kit for 3-row on-roof mounting (here: VTK 570/2)

4 Before installation

		Number of collectors per row		1	2	3	4	5	6	7	8	9	10	11	12	13	14	
		Number of rows		3														
VTK 570/2	Connecting kit VTK (basic module) Part No. 0020076785		3 ¹⁾															
	Connecting kit VTK (expansion module) Part No. 0020076779		-	3	6	9	12	15	18	21	24	27	30	33	36	39		
	Bracket kit Type P (pantile) Part No. 0020067273		a	1 ²⁾	2 ²⁾	3 ²⁾	4 ²⁾	5 ²⁾	6 ²⁾	7 ²⁾	8 ²⁾	9 ²⁾	10 ²⁾	11 ²⁾	12 ²⁾	13 ²⁾	14 ²⁾	
	Bracket kit Type S Part No. 0020067275																	
	Bracket kit Type S flat Part No. 0020080145																	
	Bracket kit Type P (pantile) Part No. 0020067274		B	2 ²⁾	4 ²⁾	6 ²⁾	8 ²⁾	10 ²⁾	12 ²⁾	14 ²⁾	16 ²⁾	18 ²⁾	20 ²⁾	22 ²⁾	24 ²⁾	26 ²⁾	28 ²⁾	
	Bracket kit Type S Part No. 0020067276																	
	Bracket kit Type S flat Part No. 0020080147																	
	Rail kit (2), VTK 570/2 Part No. 0020076780			3	6	9	12	15	18	21	24	27	30	33	36	39	42	
		Number of collectors per row		1	2	3	4	5	6	7	X							
		Number of rows		3														
VTK 1140/2	Connecting kit VTK (basic module) Part No. 0020076785		3 ¹⁾															
	Connecting kit VTK (expansion module) Part No. 0020076779		-	3	6	9	12	15	18									
	Bracket kit Type P (pantile) Part No. 0020067273		a	1 ²⁾	2 ²⁾	3 ²⁾	4 ²⁾	5 ²⁾	6 ²⁾	7 ²⁾								
	Bracket kit Type S Part No. 0020067275																	
	Bracket kit Type S flat Part No. 0020080145																	
	Bracket kit, Type P (pantile) Part No. 0020067274		B	2 ²⁾	4 ²⁾	6 ²⁾	8 ²⁾	10 ²⁾	12 ²⁾	14 ²⁾								
	Bracket kit Type S Part No. 0020067276																	
	Bracket kit Type S flat Part No. 0020080147																	
Rail kit (2), VTK 1140/2 Part No. 0020076781			3	6	9	12	15	18	21									

1) when the connections between the rows are made by flat seal connection.
2) applies up to 700 m above sea level

Table 4.5 Components for 3-row on-roof mounting

4.3.2 Flat-roof mounting

Number of collectors		1	2	3	4	5	6	7	8	9	10	11	12	13	14		
VTK 570/2	Connecting kit VTK (basic module) Part No. 0020076785	1 ¹⁾															
	Connecting kit VTK (expansion module) Part No. 0020076779	-	1	2	3	4	5	6	7	8	9	10	11	12	13		
	Mounting kit for open-air installation on a flat roof Part No. 0020076778	2	3	4	5	6	7	8	9	10	11	12	13	14	15		
	Gravel trays required	4	6	8	10	12	14	16	18	20	22	24	26	28	30		
	Gravel tray kit (2 pcs.) Part No. 0020059904	2	-	1	2	-	1	2	-	1	2	-	1	2	-		
	Gravel tray kit (3 pcs.) Part No. 0020059905	-	2	2	2	4	4	4	6	6	6	8	8	8	10		
	Rail kit (2), VTK 570/2 Part No. 0020076780	1	2	3	4	5	6	7	8	9	10	11	12	13	14		
VTK 1140/2	Connecting kit VTK (basic module) Part No. 0020076785	1 ¹⁾						X									
	Connecting kit VTK (expansion module) Part No. 0020076779	-	1	2	3	4	5										6
	Mounting kit for open-air installation on a flat roof Part No. 0020076778	2	3	4	5	6	7										8
	Gravel trays required	8	12	16	20	24	28										32
	Gravel tray (2 pcs.) Part No. 0020059904	1	-	2	1	-	2										1
	Gravel tray (3 pcs.) Part No. 0020059905	2	4	4	6	8	8										10
	Rail kit (2) aluminium, VTK 1140/2 Part No. 0020076781	1	2	3	4	5	6										7
Number of collectors VTK 1140/2		-	1	2	3	4	5	6									
Number of collectors VTK 570/2		-	1	1	1	1	1	1									
VTK 1140/2 + VTK 570/2	Connecting kit VTK (basic module) Part No. 0020076785	-	1 ¹⁾						X								
	Connecting kit VTK (expansion module) Part No. 0020076779	-	1	2	3	4	5	6									
	Mounting kit for open-air installation on a flat roof Part No. 0020076778	-	3	4	5	6	7	8									
	Gravel trays required	-	8	12	16	20	24	28									
	Gravel tray kit (2 pcs.) Part No. 0020059904	-	1	-	2	1	-	2									
	Gravel tray kit (3 pcs.) Part No. 0020059905	-	2	4	4	6	8	8									
	Rail kit (2), VTK 1140/2 Part No. 0020076781	-	1	2	3	4	5	6									
	Rail kit (2), VTK 570/2 Part No. 0020076780	-	1														

1) 1 each per collector array

Table 4.6 Flat roof installation components

4 Before installation

4.4 Interconnection scheme

 **Note**
Observe the planning information when dimensioning the array volume flow.

Furthermore, observe the following rules:

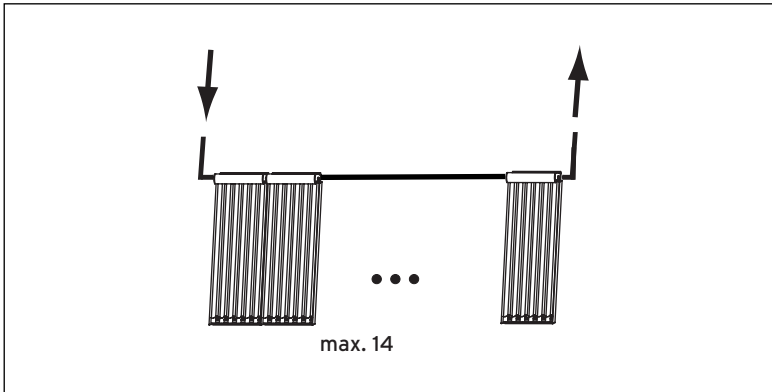

Fig. 4.6 Series connection VTK 570/2

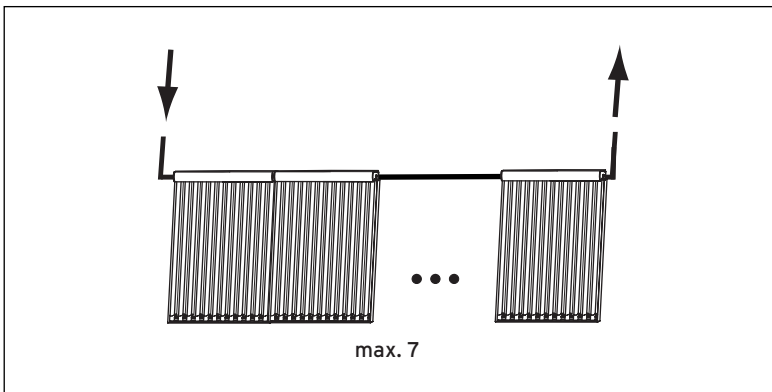

Fig. 4.7 Series connection VTK 1140/2

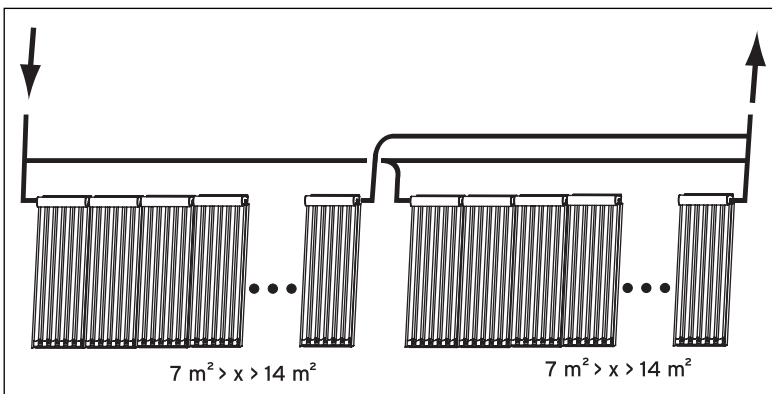



Fig. 4.8 Parallel connection (here VTK 570/2)

- Connect a maximum of **14x VTK 570/2** (corresponding to an aperture area of 14 m²) in series.

- Connect a maximum of **7x VTK 1140/2** (corresponding to an aperture area of 14 m²) in series.

- For aperture areas greater than 14 m², you must configure several collector arrays in parallel and connect them hydraulically in parallel.
- Always connect as many collectors as possible in series.

 **Note**
You should only connect the collector arrays in parallel if the aperture area is greater than 7 m² (corresponding to 7x VTK 570/2 or 3x 1140/2 + 1x VTK 570/2).

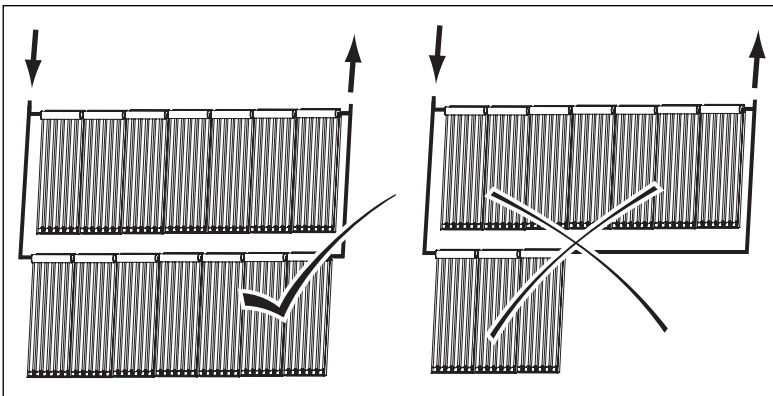

Fig. 4.9 Sizes of the individual arrays

When collector arrays are connected in parallel, each individual array must have the same aperture area.

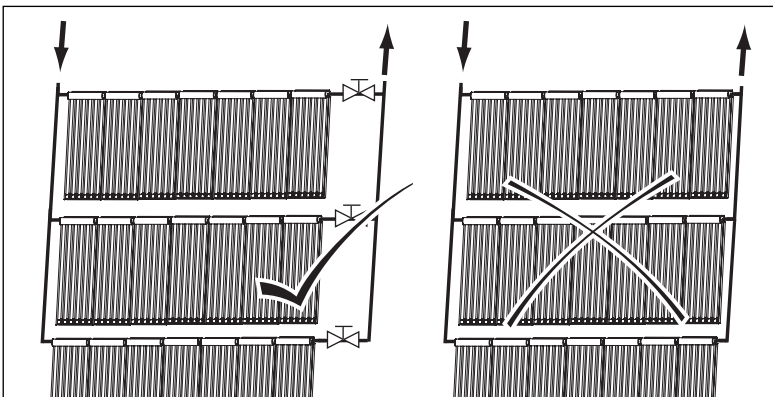

Fig. 4.10 Stop valve in the collector supply line



Caution!

Danger of air locks!

If 3 or more collector arrays are connected in parallel, a stop valve must be fitted in the collector supply line (hot side) of each individual array. These will be used for venting the individual arrays during commissioning. Only use the Vaillant stop valve, Part No. 0020076784



Caution!

Danger of damage to the material as a result of incorrect assembly!

With the valve closed or wrong valve positioning, damaging of the collector due to excessive pressure will be possible. Never mount the stop valve in the collector return. The stop valve must be open during system operation.

4 Before installation

5 On-roof mounting

4.5 Preparing the hydraulic connection

4.5.1 On-roof mounting

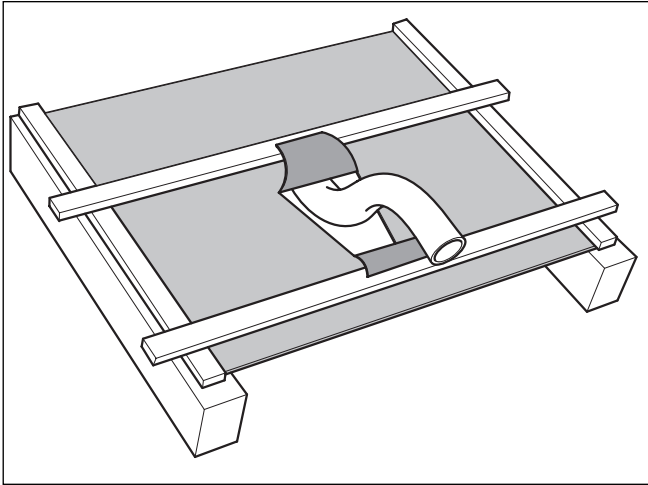

Fig 4.11 Passing the pipe through the sarking membrane

If there is a sarking membrane, proceed as follows:

- Make a v-shaped cut in the sarking membrane.
- Fold the upper, wider flap on to the roof batten above, and the lower, narrower flap on to the roof batten below.
- Fix the sarking membrane tight to the roof batten. This ensures that the dampness flows away to the side.
- With board-clad roofs, cut out a hole with a padsaw.
- Work the roofing felt as described for the sarking membrane.

4.5.2 Flat-roof mounting



Caution!

**The roof skin can break and cause leaks!
When installing the roof sealing surfaces, make sure the roof skin is adequately protected.**

- Place large protection mats under the system.
- If the frame is screwed directly, check the sealing of the building shell.

4.6 Required tools

- Have the following tools ready for assembling the tube collectors.

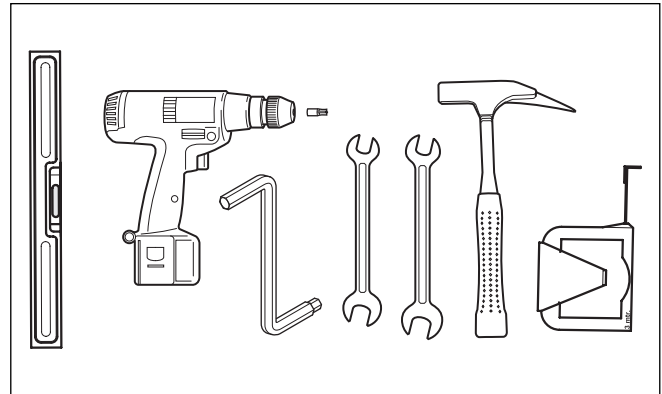

Fig. 4.12 Assembly tools: spirit level, cordless screwdriver, Torx bit (TX30, supplied), allen key 5mm, socket/combination wrench (13 mm), hammer, measuring tape / folding rule

5 On-roof mounting

With on-roof mounting, the tube collectors are fastened to horizontal mounting rails quickly and reliably with attachment clips. To ensure a good adaptation to the different roofings, four different brackets are available:

- Type P for standard concrete tiles (e.g. pantile),
- Type S for extremely high protruding tiles (e.g. Mediterranean clay tiles)
- Type S flat (low profile) for flat tiles or slate roofs.
- Stair bolt mounting kit for universal fixing (e.g. corrugated slabs, sheet with trapezoidal corrugations, shingles).



Caution!

Risk of corrosion!

On roofs made of metals more noble than aluminium (e.g. on copper roofs) galvanic corrosion can occur at the anchor points, whereby the attachment of the collectors is no longer guaranteed. Ensure that the metals are separated by suitable underlays.

When mounted on the roof, the Vaillant tube collectors in the collector array can be arranged side-by-side or above each other.

In general, the installation steps and instructions described in this manual are applicable to all collector arrangements.

Any different installation steps are clearly pointed out:



For collectors arranged side-by-side



For collectors arranged above each other

When arranging the collectors, take note in each case of the possible interconnection schemes in Section 4.4.

5.1 Fitting the brackets



For collectors arranged side-by-side

- Mount the anchors for the mounting rails at the following distances:



Note
 During final fixing the pre-assembly dimension **A** is reduced by approx. 20 - 25 mm. Take care that there is adequate clearance on the anchors, therefore.

	Number of collectors	A*	B	C	D
VTK 570/2	1	1663 / 1638	50 - 100	507 - 607	707
	2				1414
	3				2121
	4				2828
	5				3535
	6				4242
	7				4949
	8				5656
	9				6363
	10				7070
	11				7777
	12				8484
	13				9191
	14				9898
VTK 1140/2	1	100 - 200	997 - 1197	1397	
	2			2794	
	3			4191	
	4			5588	
	5			6985	
	6			8382	
	7			9779	

* Pre-assembly dimension / Finished dimension
 During final fixing of the collectors, the pre-assembly dimension is reduced by approx. 20 - 25 mm.

Table 5.1 Spacings when arranging collectors side-by-side [in mm]

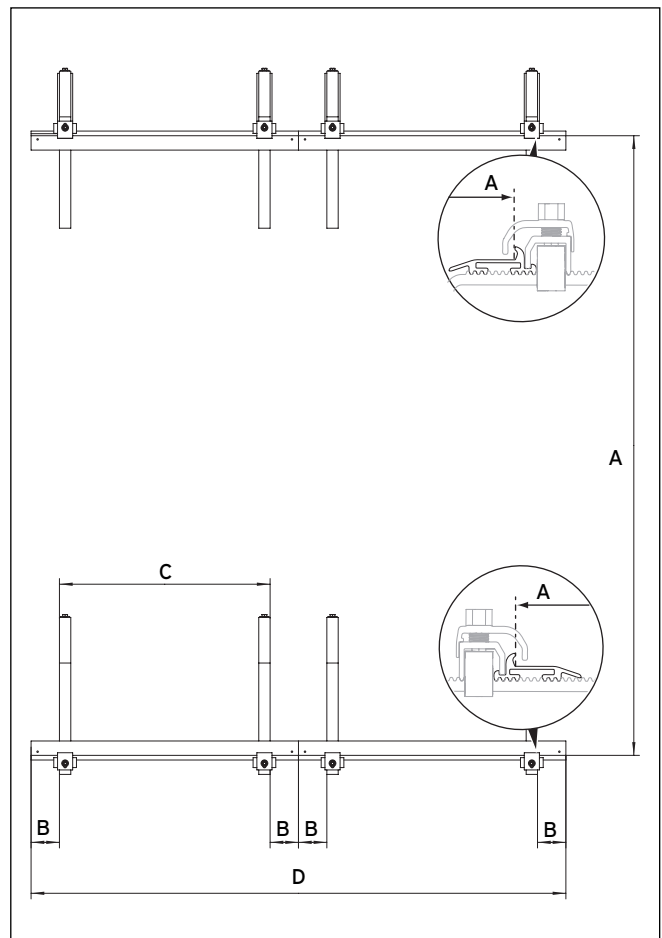

Fig. 5.1 Spacings when arranging collectors side-by-side

5 On-roof mounting



For collectors arranged on top of each other

- Mount the anchors for the mounting rails at the following distances:



Note

During final fixing the pre-assembly dimension **A** is reduced by approx. 20 - 25 mm. Take care that there is adequate clearance on the anchors, therefore.

	Number of collectors	A*	B	C	D	E 2 rows	E 3 rows
VTK 570/2	1	1663 / 1638	50 - 100	507 - 607	707	3322	5006
	2				1414		
	3				2121		
	4				2828		
	5				3535		
	6				4242		
	7				4949		
	8				5656		
	9				6363		
	10				7070		
	11				7777		
	12				8484		
	13				9191		
	14				9898		
VTK 1140/2	1	1663 / 1638	100 - 200	997 - 1197	1397	3322	5006
	2				2794		
	3				4191		
	4				5588		
	5				6985		
	6				8382		
	7				9779		

* Pre-assembly dimension / Finished dimension
During final fixing of the collectors, the pre-assembly dimension is reduced by approx. 20 - 25 mm.

Table 5.2 Spacings when arranging collectors on top of each other [in mm]

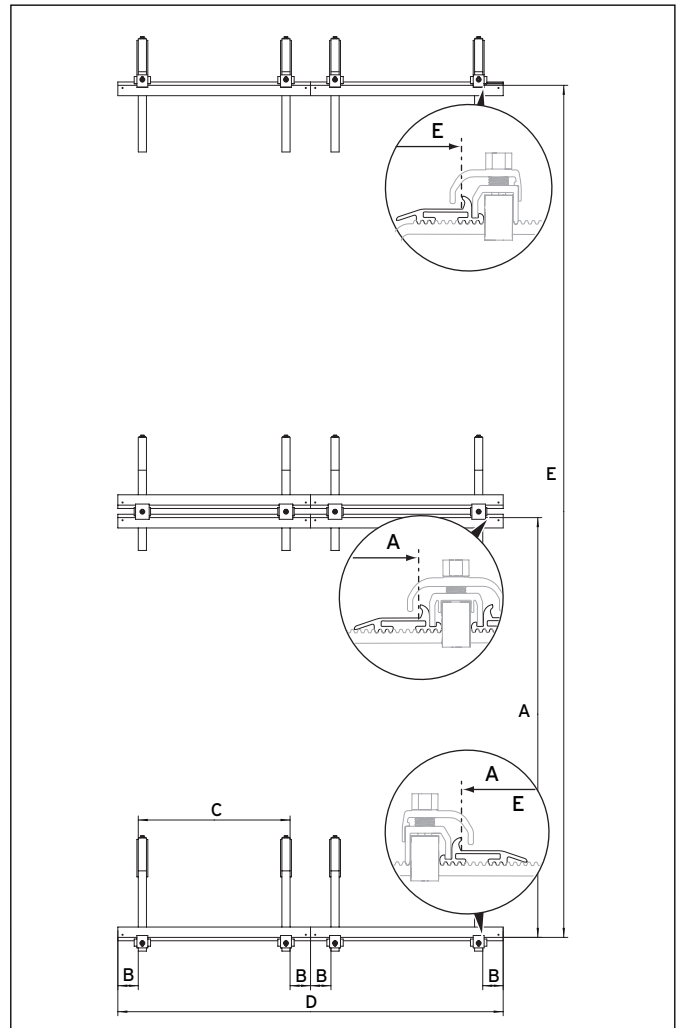

Fig. 5.2 Spacings when arranging collectors on top of each other

5.2.1 Bracket Type P (pantile)

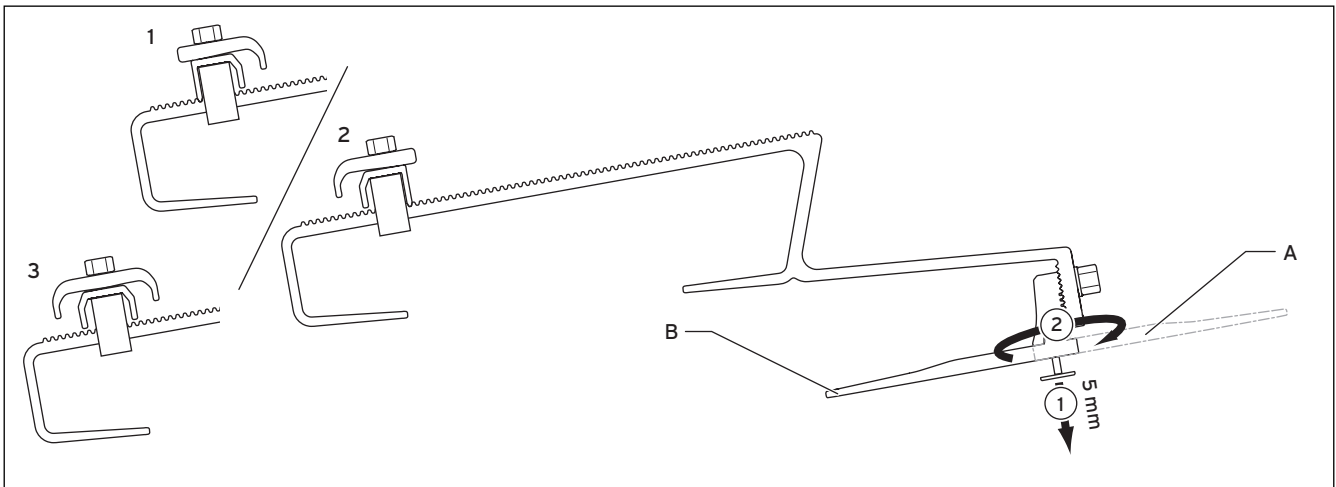

Fig. 5.3 Bracket type P

Key

- 1 Lower bracket
- 2 Upper bracket
- 3 Central bracket

The bracket type P can be fixed to the **rafters** (**Pos. A**) or by use of the long rear plate set 0020080177 can be offset to suit tile profile.

Fixing to rafters

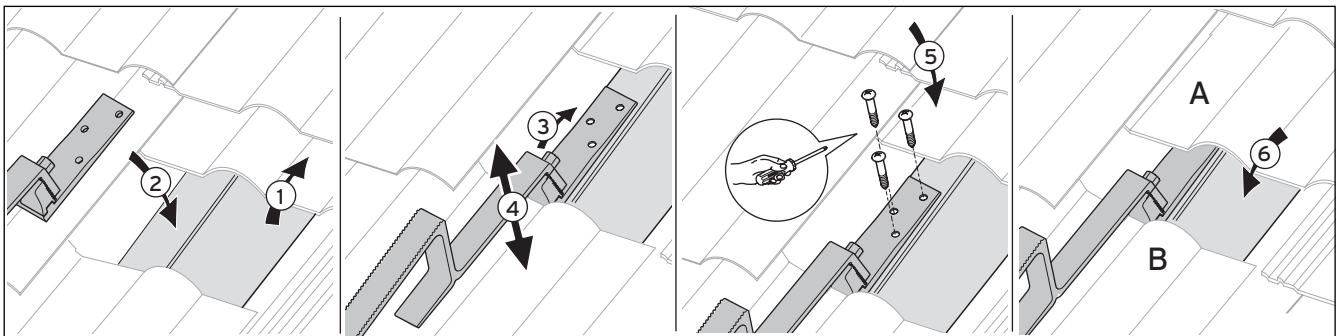

Fig. 5.4 Fixing to rafters

1. Uncover the rafters where needed. For distances please see Tab. 5.1 and 5.2.
2. Position the bracket. Take note of the correct positions of the upper, central and lower brackets (see Fig. 5.3).
3. Loosen the upper bolt with the socket/combination wrench (13 mm) until the height of the bracket can be adjusted.
4. Position the bracket at the same height of the pantiles, so that the upper part of the anchor is on the roofing, and tighten the bolt with the socket/combination wrench (13 mm).
5. Screw the bracket to the rafters with the 3 supplied bolts.
6. Slide the pantiles back to the original position. If necessary, adapt the water gutter on the lower (**A**) or upper side (**B**) of the pantile with a hammer, or suitable disk cutter, until the pantiles are tight.



Danger!

Risk of injury!

Always wear suitable eye protection and all necessary personal protective equipment and ensure the area of work is safe with regard to other persons.

5 On-roof mounting



Note

With some roof covering it may be necessary to offset the roof bracket to the left or right of the rafter, to do this use the accessory: Part No. 0020080177 (not available in every country). Observe the appropriate installation manual.

Fixing to the roof batten



Caution!

Only acceptable if roof and battens have been inspected by a competent roofing contractor / designer.

Before installation on the roof batten, check the load capacity of the roof batten!

If necessary, replace the roof batten or provide additional timber bearers.

Also ensure battens are fixed securely (screw to rafter each side of brackets).

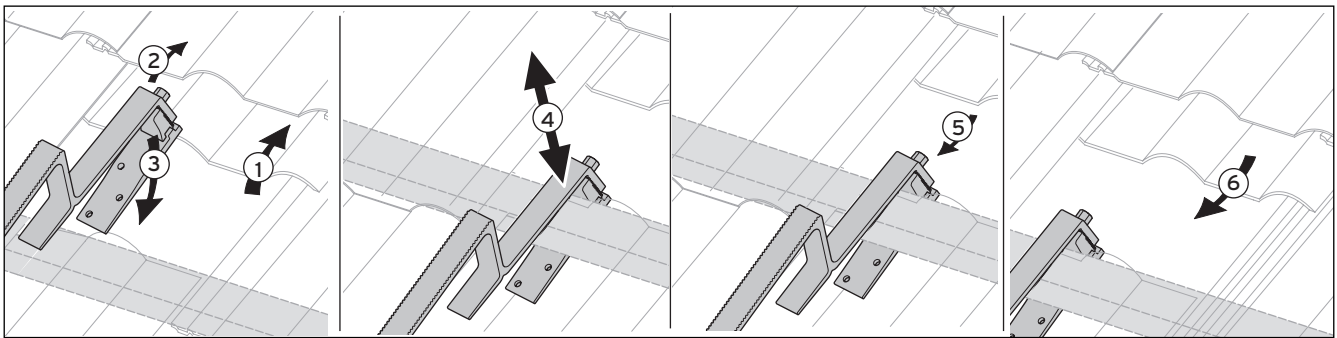

Fig. 5.5 Fixing to the roof batten

1. Slide upward one or two pantiles above the roof batten.
For distances please see Tab. 5.1 and 5.2.
2. Loosen the upper bolt with the socket/combination wrench (13 mm) until the height of the bracket can be adjusted.
3. Hook the bracket to the roof batten. Take note of the correct positions of the upper, central and lower brackets when doing this (see Fig. 5.3).

4. Position the bracket at the same height of the pantiles. The upper part is on the roofing, the lower part is pressed tight against the roof batten from the bottom.
Take care anchor is tightly fixed and pre-tensioned on the roof batten (toothing engaged).
5. Tighten the bolt with the socket/combination wrench (13 mm).
6. Slide the pantiles back to the original position. If necessary, adapt the water gutter on the lower side of the pantile with a hammer, until the pantiles are tight

5.2.2 Bracket Type S (for high profile pantiles)

Caution!
Before installation on the roof batten, check the load capacity of the roof batten!
If necessary, replace the roof batten.

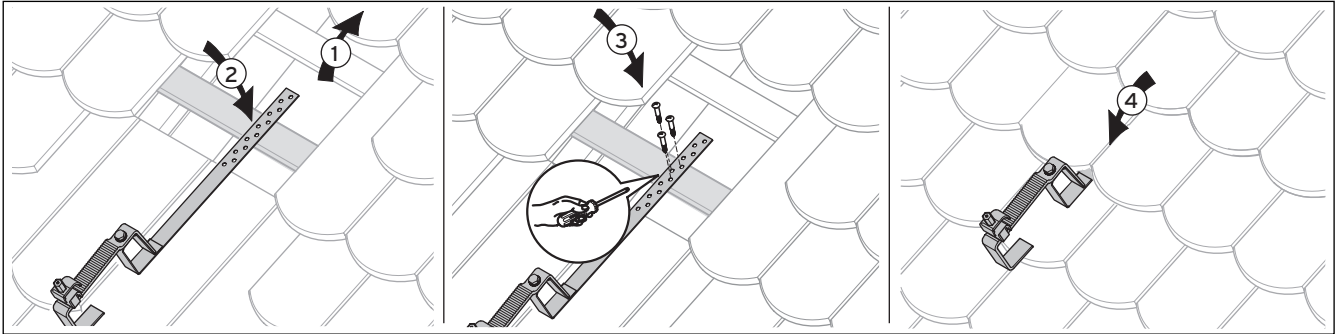

Fig. 5.6 Fixing the bracket type S

1. Uncover the rafters or the roof batten where needed. For distances please see Tab. 5.1 and 5.2.
2. Position the bracket. Take note of the correct positions of the upper, central and lower brackets (see Fig. 5.3).
3. Screw the bracket to the rafters/roof batten with the 3 supplied bolts.
4. Slide the pantiles back to the original position.

5.2.3 Bracket Type S (Low profile for slate/ flat tiles)

Caution!
Only acceptable if roof and battens have been inspected by a competent roofing contractor / designer.
Before installation on the roof batten, check the load capacity of the roof batten!
If necessary, replace the roof batten or provide additional timber bearers.
Also ensure battens are fixed securely (screw to rafter each side of brackets).

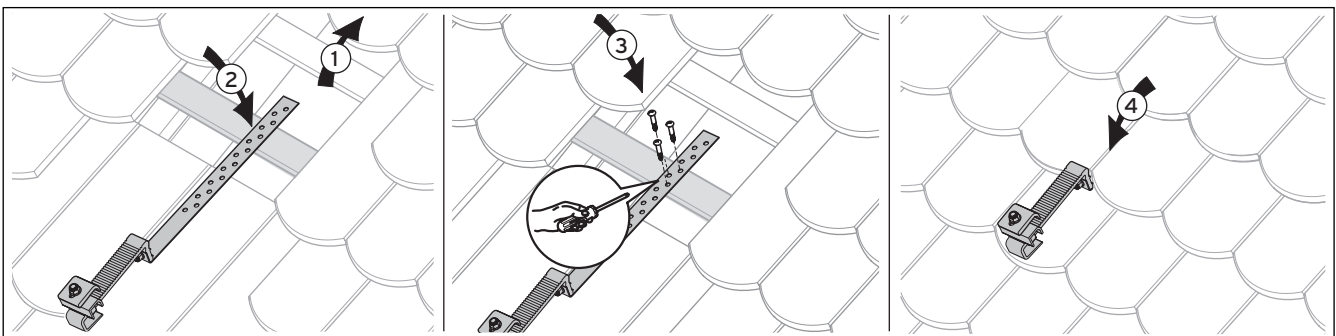

Fig. 5.7 Fixing the bracket type S flat

1. Uncover the rafters or the roof batten where needed. For distances please see Tab. 5.1 and 5.2.
2. Position the bracket. Take note of the correct positions of the upper, central and lower brackets (see Fig. 5.3).
3. Screw the bracket to the rafters/roof batten with the 3 supplied bolts.
4. Slide the pantiles back to the original position.

5 On-roof mounting

5.2.3 Hanger bolt fixing kit



Caution!

Before installation check the load-bearing capacity of the wooden substructure!

If necessary, strengthen it.

Only for use on roof structures with timbers large enough to accept stair bolt.

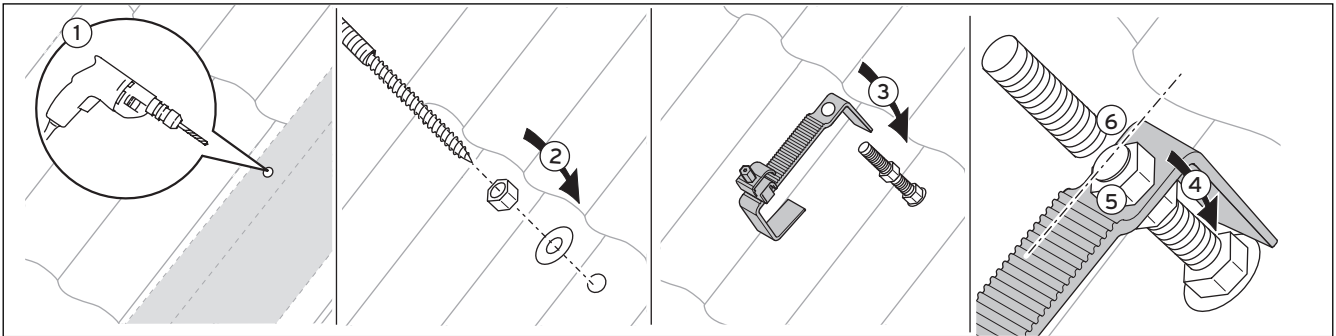

Fig. 5.8 Fixing with stair bolt

1. Bore a hole in the roof covering in the corresponding position. For distances please see Tab. 5.1 and 5.2.
2. Tighten the stair bolt to the rafters through the pan-tile.
3. Screw the lower nut against the roof covering, and tighten it until the seal sufficiently seals the opening.

4. Position the central nut so that after inserting the anchor upper part the front contact area is on the roofing. Take note of the correct positions of the upper, central and lower brackets when doing this (see Fig. 5.3).
5. Screw the second nut and tighten it (17 mm).
6. Cut off the threaded bolt directly above the nut. Deburr the interface.

5.3 Fitting the collectors

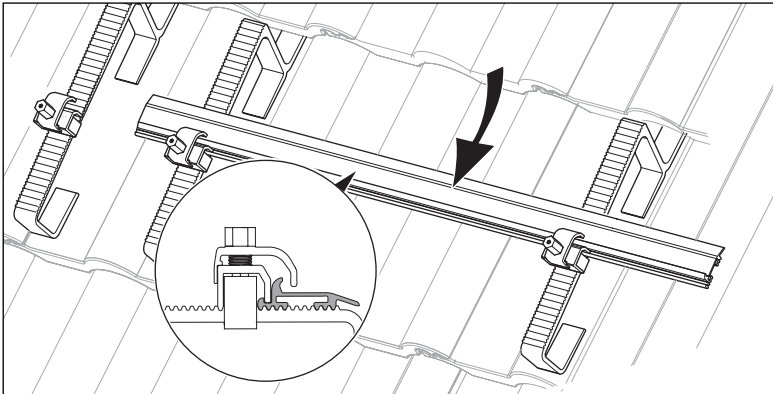

Fig. 5.9 Fixing the mounting rails

- Fix the horizontal mounting rails with the frame clamping elements on the brackets.

Note
For the vertical spacing between the brackets please see Tables 5.1 and 5.2.

Note
For a better visual appearance, position the lower rail as low as possible on the bracket.

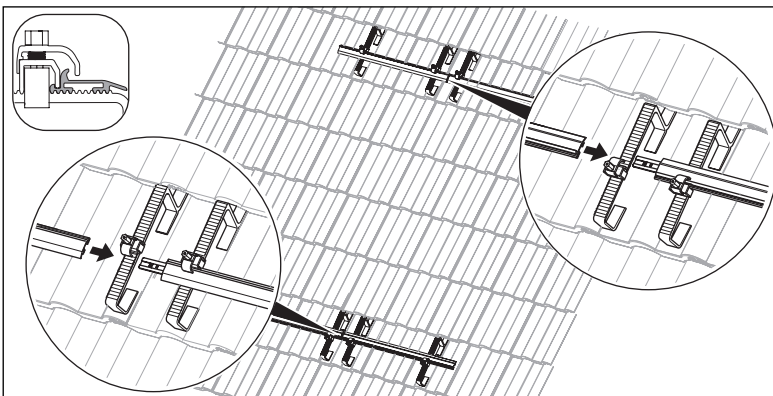

Fig. 5.10 Joining the mounting rails

- Insert the connecting elements into the mounting rails by the side, until they lock into place.
- Join the mounting rails and fix them with the clamping elements on the brackets (see Fig. 5.8).

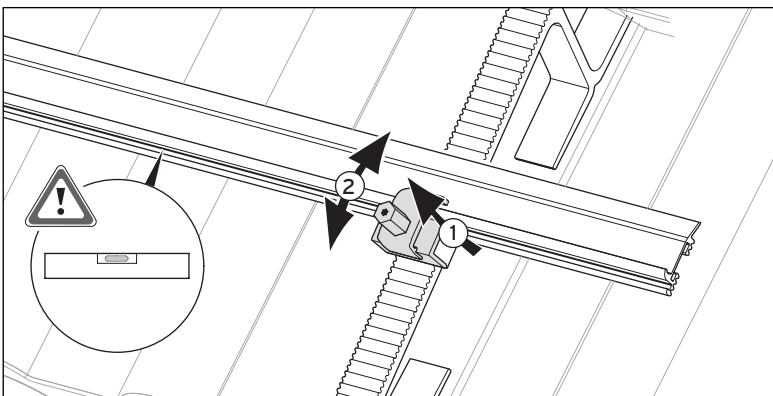

Fig. 5.11 Balancing the mounting rails

- Make sure that the mounting rails are fixed in horizontal position.
- Compensate any difference in height by moving the clamping elements.
- Pull the clamping element upward, now it can be moved and it engages again when released.

5 On-roof mounting

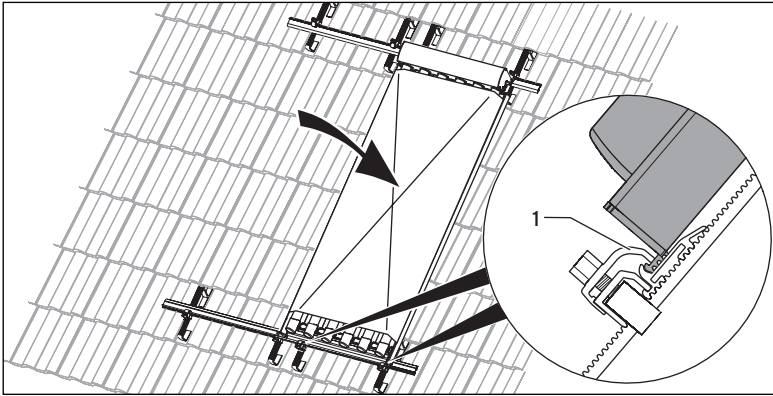

Fig. 5.12 Hooking the collector

- Place the collector with the lower edge on the mounting rail and hook it to the clamping elements.
- Make sure that the upper part (1) of the clamping element is above the collector rail.
- Tighten the clamping elements of the lower mounting rail with the socket/combination wrench (13 mm).



Caution!

After tightening the clamping elements, make sure the tension is correct by shaking the upper part of the clamping element. If it can be moved, retighten the nut.

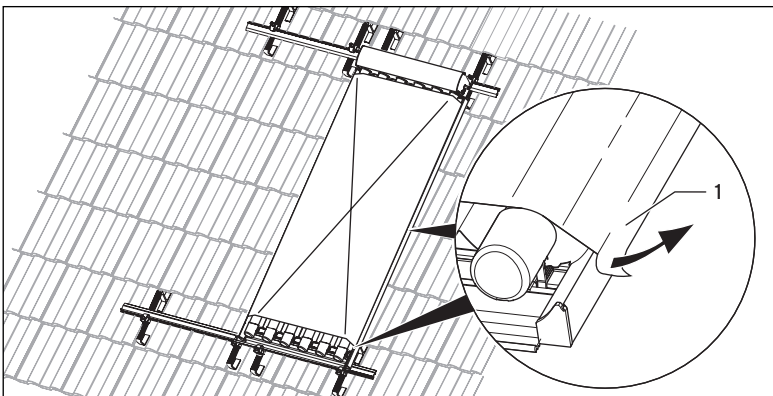

Fig. 5.13 Peeling the film from the edges of the collector

- Lift the film at the edges of the collector. This will facilitate pulling off the film later, after commissioning.



Danger!

Danger of burning!

In case of solar irradiation inside the units, collectors can reach 300 °C. Remove the sun protection film installed at the factory only after the solar energy system has been started up.

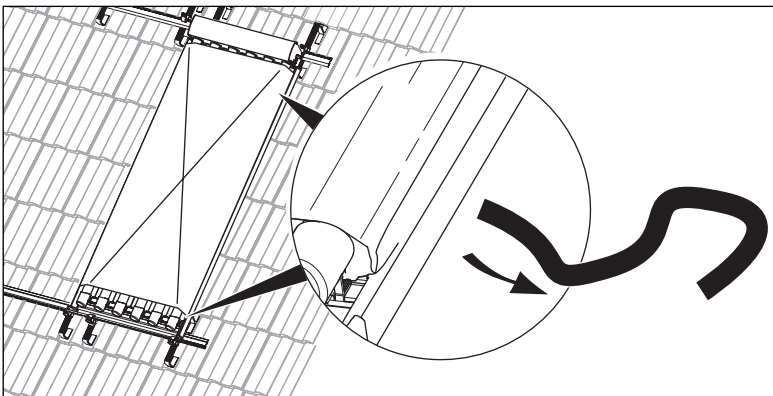

Fig. 5.14 Removing the carrying straps

- Remove the carrying straps.

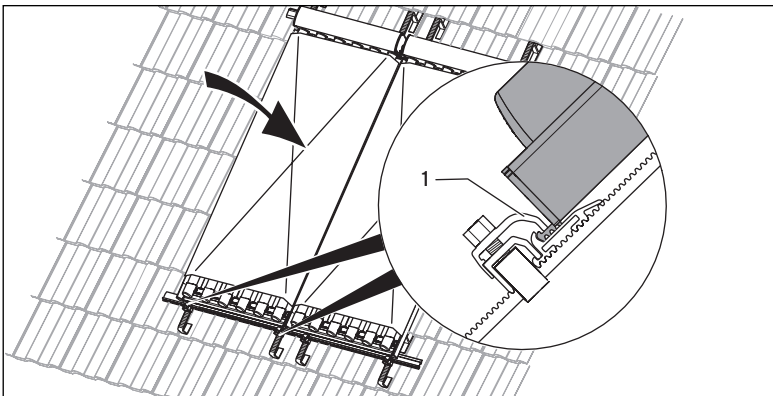

Fig. 5.15 Mounting other collectors

- Place the next collector on the lower mounting rail.
- Make sure that the upper part (1) of the clamping element is above the collector rail.
- Tighten the lower clamping elements on the collector.
- Slide the upper mounting rails and clamping elements little by little from the top against the collector.

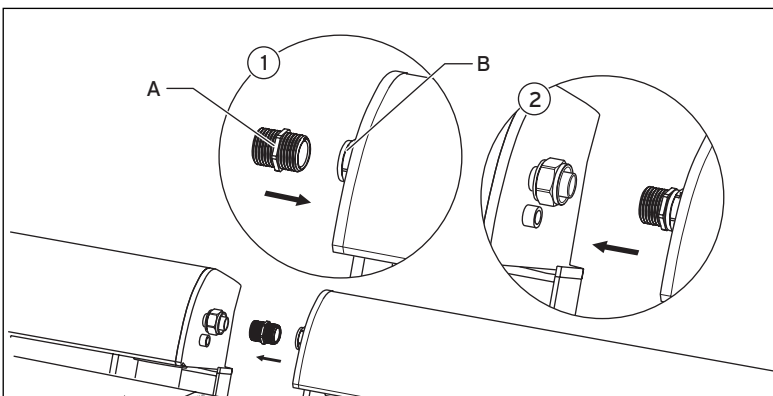

Fig. 5.16 Joining the collectors

- Couple the double nipple (A) (from the VTK expansion module connecting kit, Part No. 0020076779) to the union nut (B) on the first collector.
- Push the collectors together.

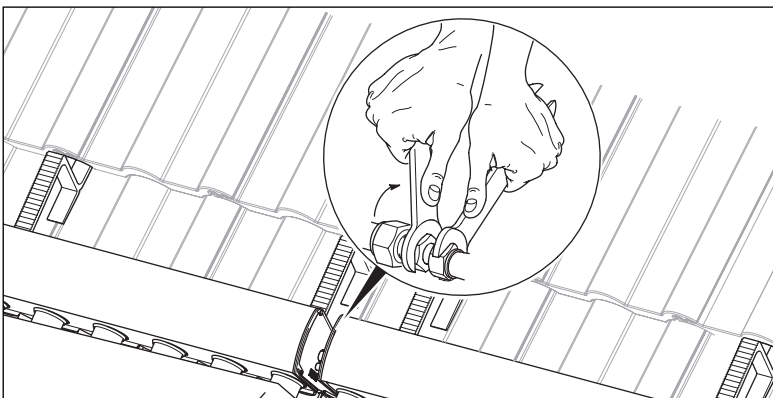

Fig. 5.17 Tightening the compression fitting

Caution!
Danger of damage to the collector as a result of incorrect assembly!
To prevent damage when tightening the compression fitting, always use a second spanner to provide a counter force.

- Tighten the two union nuts on the double nipple.

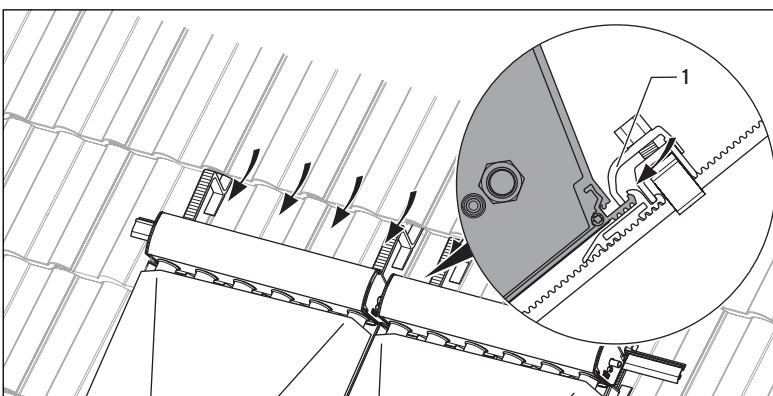

Fig. 5.18 Positioning the upper mounting rail

- Slide the upper mounting rails towards the collector.
- Take care that the upper parts of the clamping elements are over the rails on the collectors.

5 On-roof mounting

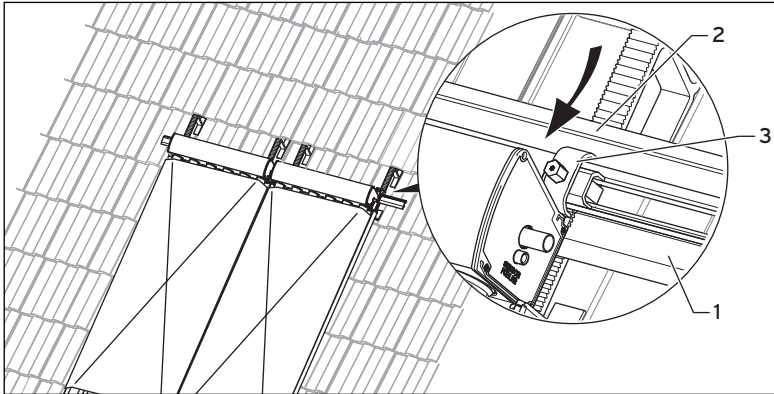

Fig. 5.19 Central mounting rail for 2 or 3 rows of collectors



For collectors arranged on top of each other

- Slide the central mounting rail flush with the lower collector (1).
- Make sure that the hook of the clamping element (3) is above the edge of the collector.
- Fix the mounting rail (2) for the next row of collectors to the clamping element.

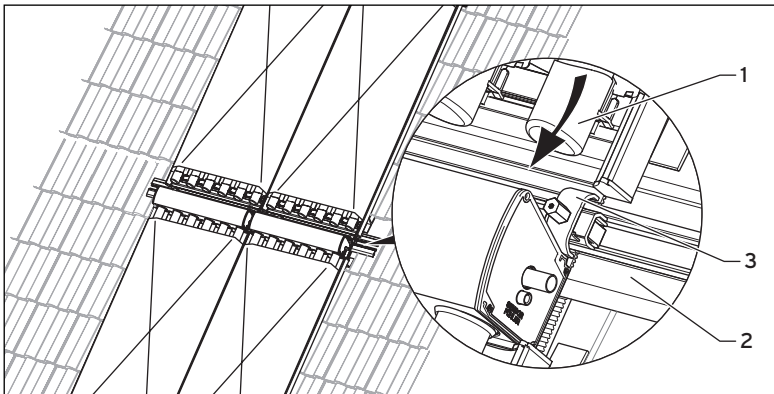

Fig. 5.20 Central mounting rail for 2 or 3 rows of collectors



For collectors arranged on top of each other

- Place the upper collector (1) in the central mounting rail (2).
- Screw the clamping elements (3) on the central rail tight.
- Fit the second row of collectors as described above.

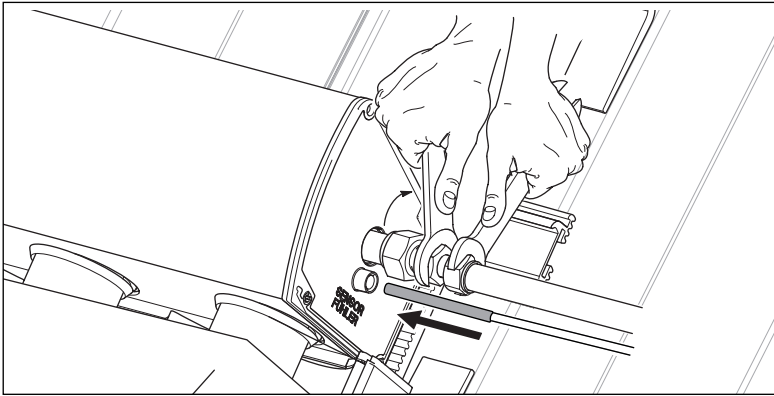

Fig. 5.21 Fitting the hydraulic connections

- **For systems with collector sensors:** Plug the collector sensor into the opening provided on the flow side of the collector (hot side).

With several rows of collectors:

- Connect the rows of collectors in accordance with the interconnection schemes (cf. Section 4.4).



Note

In general it is possible to attach the collector sensor to the left or the right side of the collector array, as the collectors have a corresponding opening on each side. Ensure VR11 sensors are fitted to the hot side of the collector array.



Caution!

Danger of damage to the collector as a result of incorrect assembly! To prevent damage when tightening the compression fitting, always use a second spanner to provide a counter force.

- Connect the collector supply and return to the system with the connection pipes.
- To do this, connect the compression fitting (from the VTK basic module connecting kit, Part No. 0020076785) to the collector and connect this to the connecting pipe.
- If necessary check all connections for leaks.

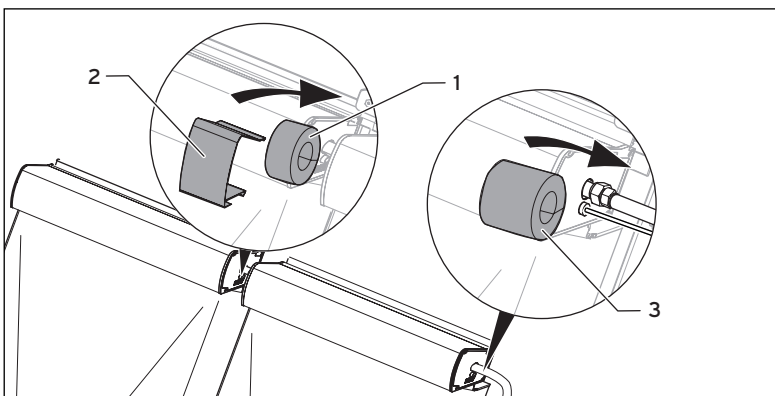

Fig. 5.22 Insulating the hydraulic connections

After commissioning:

- Insulate the hydraulic connections with the Armeflex insulation (1) (from the VTK expansion module connecting kit, Part No. 0020076779).
- Cover the insulation with the cover clip (2) (from the VTK expansion module connecting kit, Part No. 0020076779).
- Insulate the hydraulic system connections with the EPDM insulation (3) (from the VTK expansion module connecting kit, Part No. 0020076779).

6 Flat-roof mounting

6 Flat-roof mounting

With flat roof installation, the tube collectors are fastened to frames.

The flat roof frames allow for a flexible installation with an angle of 30 °, 45 ° or 60 °.

Also note that the height of the mounting rails is variable, in order to compensate for small floor irregularities.

6.2 Weighting and arrangement of the frames

First of all, define the necessary load of the frames based on Tab. 6.1.

Load [kg/collector]

Collector angle	Height above ground [m]		
	0-10	10-18	18-25
30°	70	80	90
45°	100	115	130
60°	125	140	155

Table 6.1 Flat roof installation load



Caution!

The roof may collapse!

Before installation, check the maximum roof load!

If necessary, contact a specialist roofing designer/contractor before proceeding.

Consider if the frame can be bolted to the structure as opposed to weighting.



Caution!

For determining the installation location, keep a distance of 1 m from the roof edge! A different distance causes high wind loads.

For the required space and the distances between frames please see Tables 6.2 to 6.4.

VTK 570/2 [distances in mm]										
Number of collectors	A ³⁾	30° (28.5°)		45° (42.5°)		60° (59.5°)		C	D +30	A
		B	F	B	F	B	F			
1	560 ⁴⁾	1072	2950 ²⁾	1432	3940 ²⁾	1757	4830 ²⁾	2460	584	707
2	1168									
3	1875									
4	2582									
5	3289									
6	3996									
7	4703									
8	5410									
9	6117									
10	6824									
11	7531									
12	8238									
13	8945									
14	9652									

1) Installation angle 30°, 45° oder 60°
 2) Solar altitude of 20° (winter sun)
 3) Dimension A may vary in conjunction with dimensions D and E by ±30 mm
 4) ±5 mm

Table 6.2 Dimensions for VTK 570/2 [in mm]

6 Flat-roof mounting

VTK 1140/2 [distances in mm]

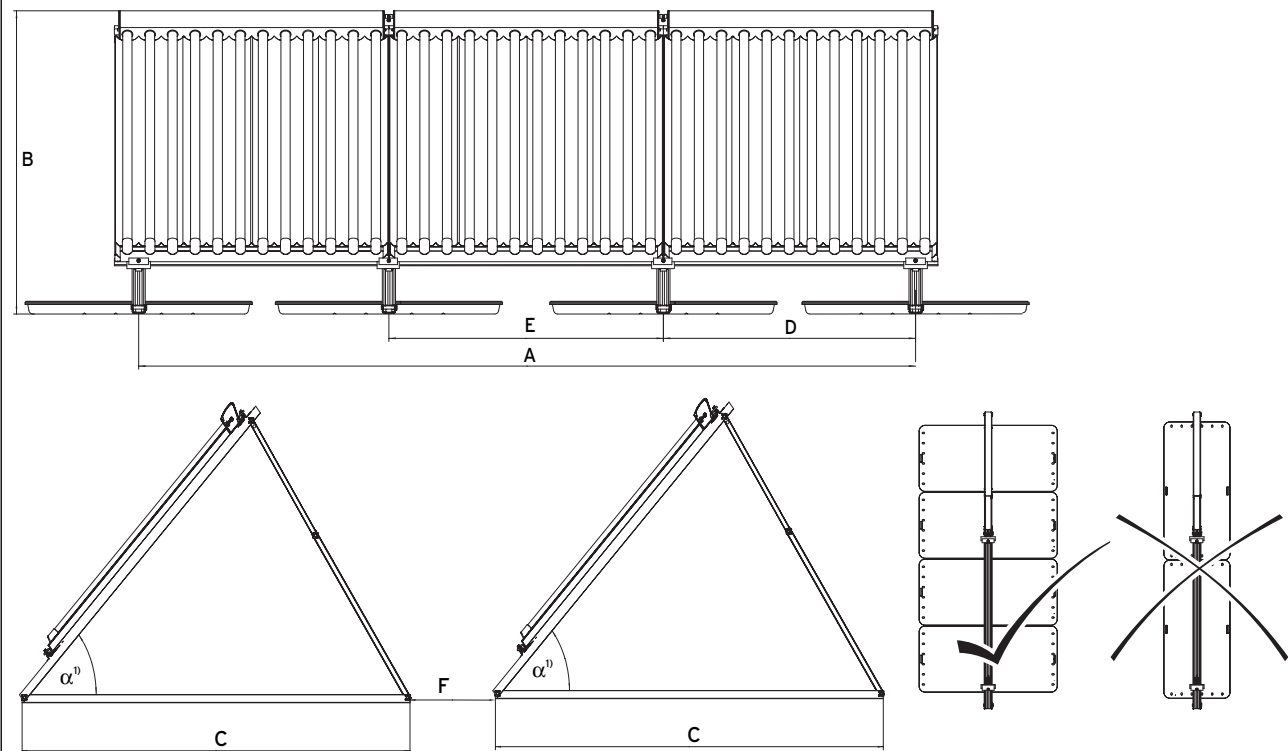

Number of collectors	A ³⁾	30°		45°		60°		C	D +30	A
		B	F	B	F	B	F			
1	1170 ⁴⁾								-	-
2	2548									
3	3945									
4	5342	1072	2950 ²⁾	1432	3940 ²⁾	1757	4830 ²⁾	2460	1274	1397
5	6739									
6	8136									
7	9533									

1) Angle of attack 30°, 45° or 60°

2) Solar altitude of 20° (winter sun)

3) Dimension A may vary in conjunction with dimensions D and E by ±30 mm

4) ±5 mm

Table 6.3 Dimensions for VTK 1140/2 [in mm]

VTK 1140/2 and VTK 570/2 in combination [distances in mm]

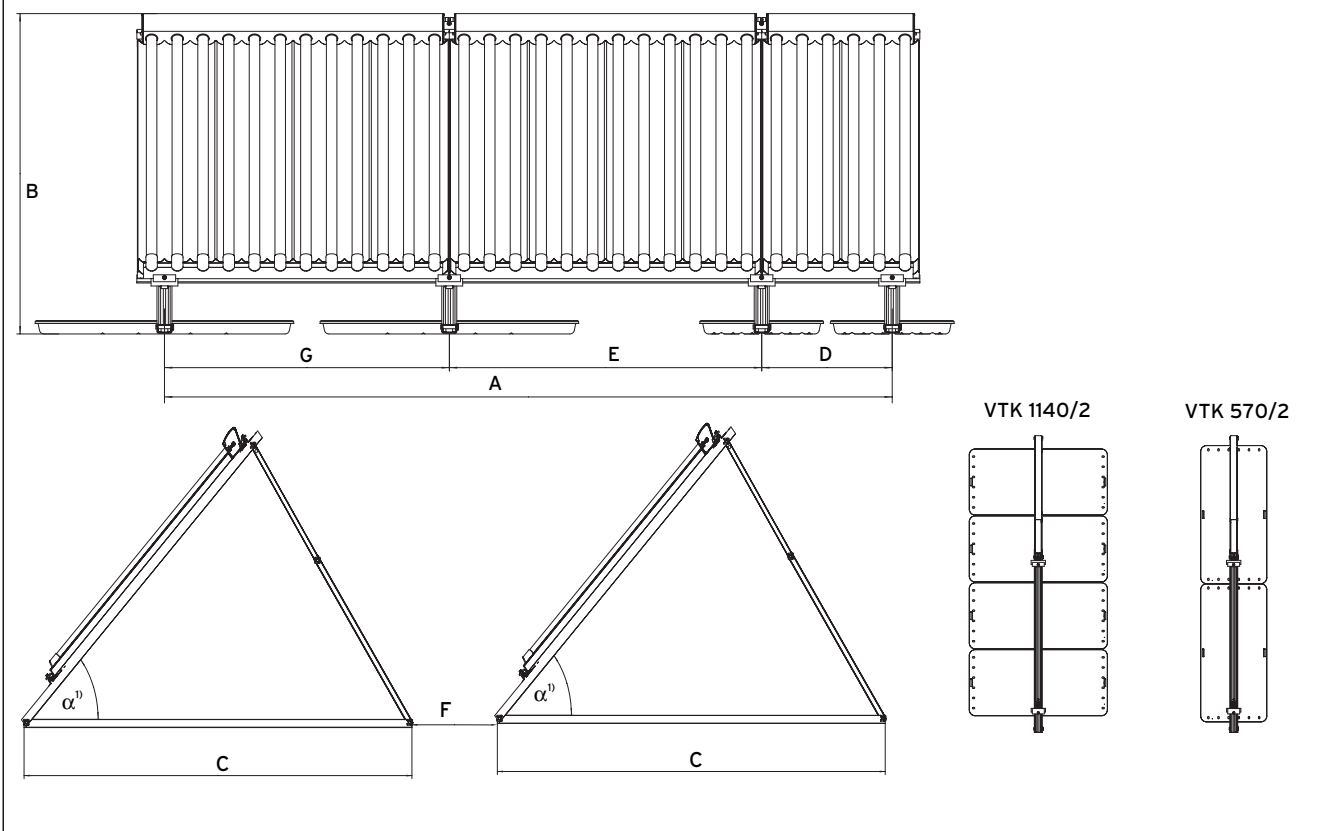

Number of collectors		A ³⁾	30°		45°		60°		C	D +30	A	G
VTK 570/2	VTK 1140/2		B	F	B	F	B	F				
1	1	1170 ⁴⁾	1072	2950 ²⁾	1432	3940 ²⁾	1757	4830 ²⁾	2460	584	1397	1274
1	2	2548										
1	3	3945										
1	4	5342										
1	5	6739										
1	6	8136										

1) Angle of attack 30°, 45° or 60°
 2) Solar altitude of 20° (winter sun)
 3) Dimension A may vary in conjunction with dimensions D and E by ±30 mm
 4) ±5 mm

Table 6.4 Dimensions for VTK 1140/2 and VTK 570/2 in combination [in mm]

6 Flat-roof mounting

6.3 Fitting the collectors

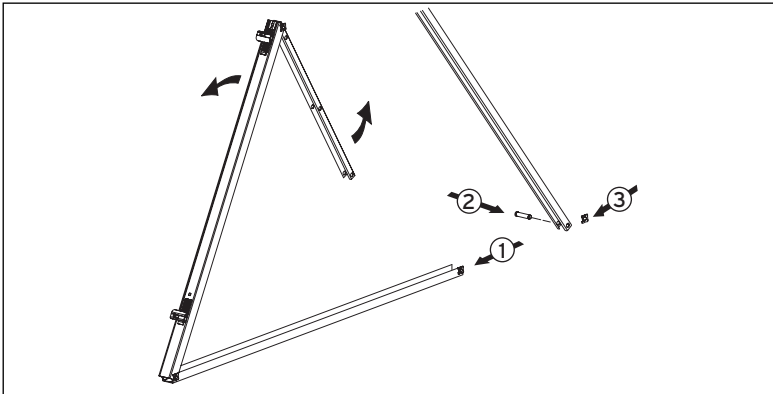

Fig. 6.1 Preparing the frame

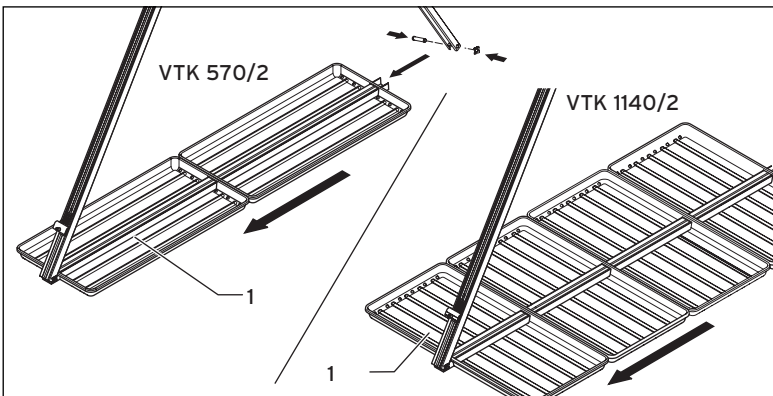

Fig. 6.2 Mounting the gravel trays

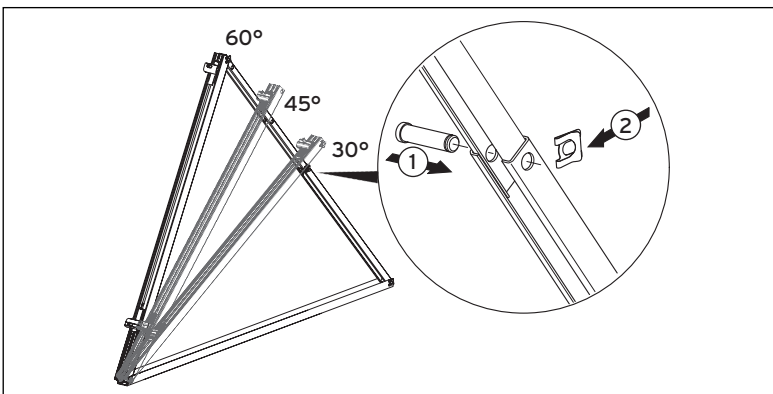

Fig. 6.3 Frame assembly

- Open the frames.

Caution!
Follow Tables 6.1 to 6.4 without exception to determine the required weights!

With screwed connection on the roof:

- Fasten the rear section to the base section with a retaining pin and locking clip.

If gravel trays are used:

- Slide the gravel tray (1) on the base section.
- Fasten the rear section to the base section with a retaining pin and locking clip.

- Insert the telescopic sections into each other, until the holes of the desired angular position are placed one above the other.

Note
You can choose settings of 30°, 45° or 60°.

- Insert the retaining pin into the corresponding hole (1).
- Fix the retaining pin with the safety clip (2).

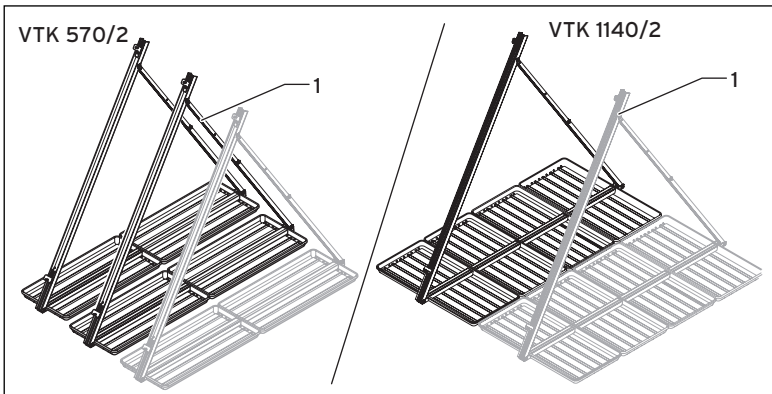

Fig. 6.4 Frames with gravel trays

If gravel trays are used:

- Place large protection mats under the system.
- Set up the frames (1) according to the number of collectors to be mounted.



Note

The weights and distances can be found in Table 6.1.



Caution!

Before mounting the collectors, fill the gravel trays on the first frame with gravel or other suitable weighting material, to give the system stability.

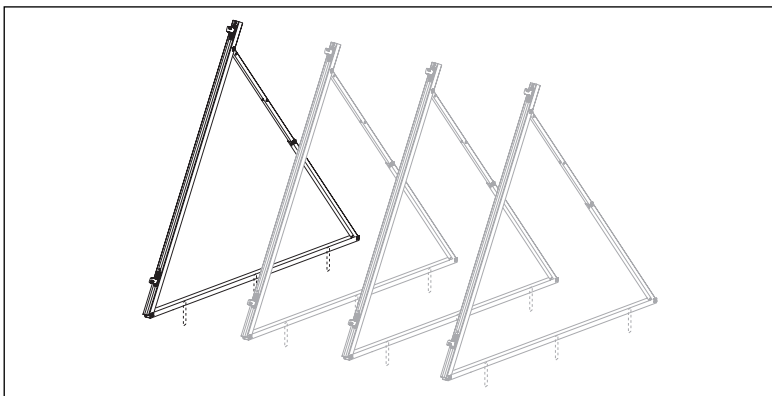

Fig. 6.5 Direct screwed connection

With screwed connection on the roof:

- Assembly frames based on the number of collectors to be installed.



Note

The weights and distances can be found in Table 6.1.

- Fix the frames on the roof.



Caution!

The roof skin can break and cause lack of tightness! When installing the roof sealing surfaces, make sure the roof skin is adequately protected.

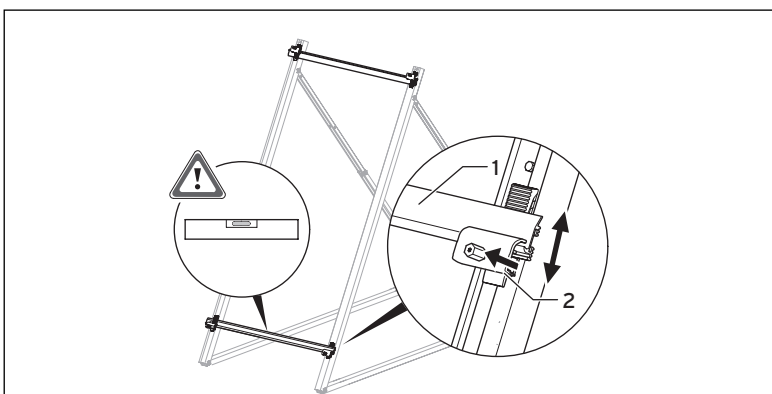

Fig. 6.6 Fixing and blocking the mounting rail

- Fasten the horizontal mounting rails (1) to the clamping elements (2) on the frames.
- Compensate for any difference in height by moving the clamping elements (2).
- Pull the lower part of the clamping element (2) upwards; now it can be moved and it engages again when released.

6 Flat-roof mounting

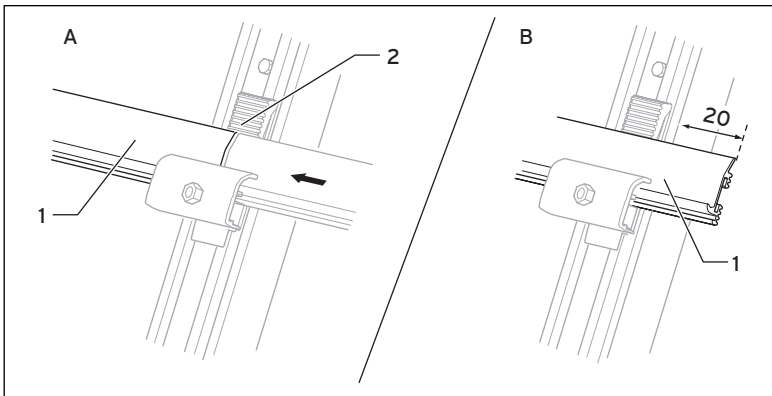

Fig. 6.7 Positioning the mounting rails

- If multiple collectors are mounted, have the mounting rails (1) meet in the centre of the frames (2) (A).
- On the first and last frame, the mounting rails (1) should project by 20 mm over the edge (B).

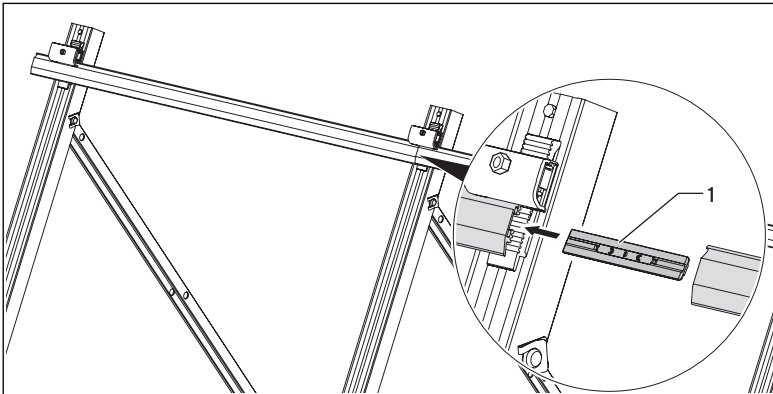

Fig. 6.8 Joining the mounting rails

- Insert the connecting elements (1) into the ends of the mounting rails.
- Join the mounting rails and fix them to the frame clamping elements.
- Compensate any difference in height by moving the clamping elements.

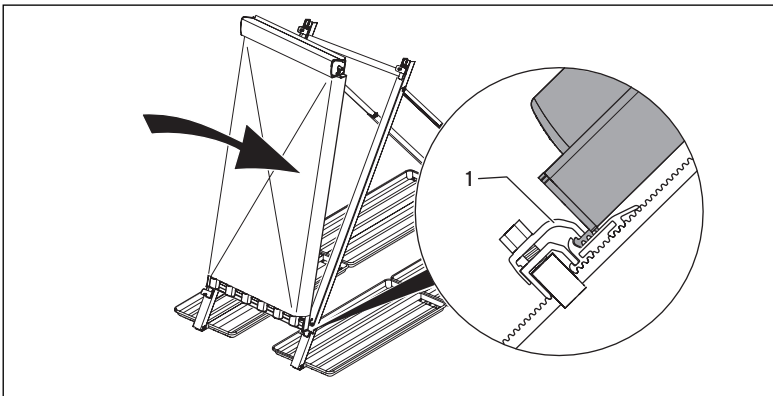

Fig. 6.9 Hooking the collector

- Place the collector with the lower edge in the section of the mounting rail.
- Position the upper part (1) of the clamping element over the rail on the collector.
- Tighten the clamping elements of the lower mounting rail with the socket/combination wrench (13 mm AF).



Caution!

After tightening the clamping elements, make sure the tension is correct by shaking the upper part of the clamping element. If it can be moved, retighten the nut.

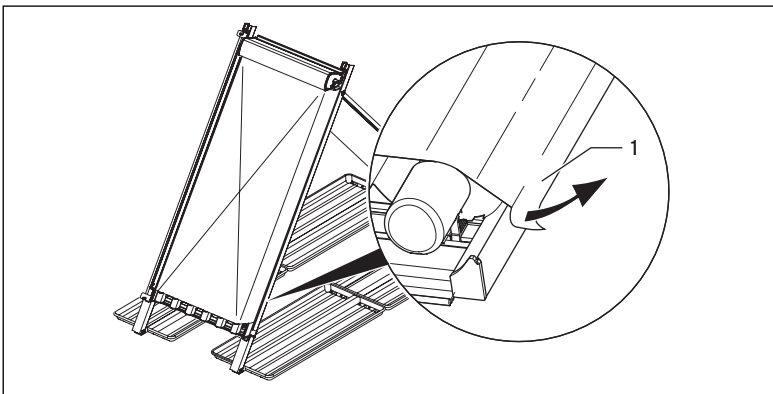

Fig. 6.10 Peeling the film from the edges of the collector

- Lift the film at the edges of the collector. This will facilitate pulling off the film later, after commissioning.



Danger!

Danger of burning!

In case of solar irradiation inside the units, collectors can reach 300 °C. Remove the sun protection film installed at the factory only after the solar energy system has been started up.

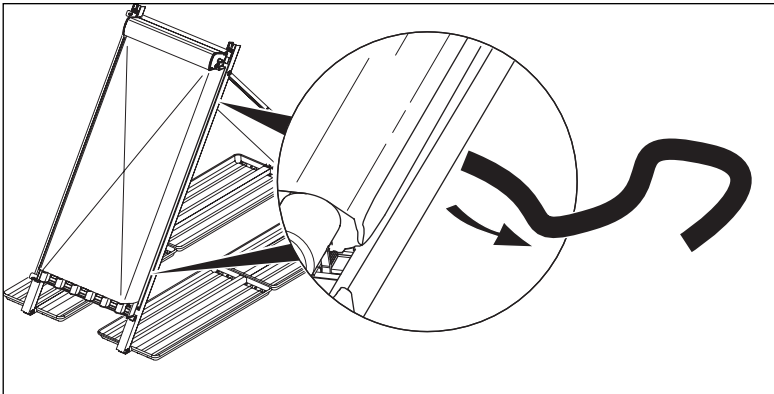

Fig. 6.11 Removing the carrying straps

- Remove the carrying straps.

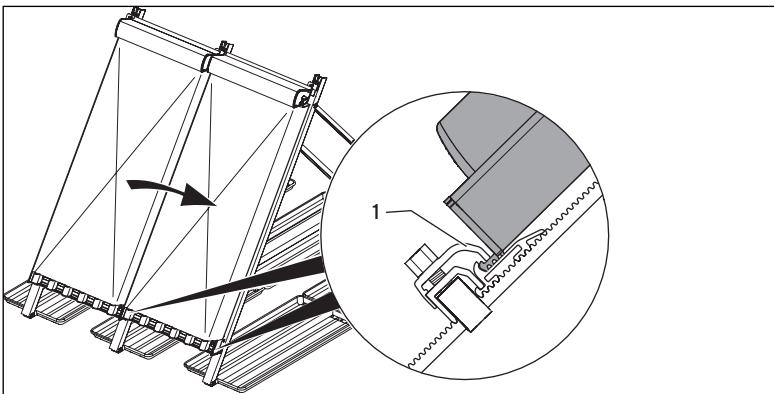

Fig. 6.12 Mounting other collectors

- Place the next collector on the lower mounting rail at a distance of approx. 10 cm from the first collector.

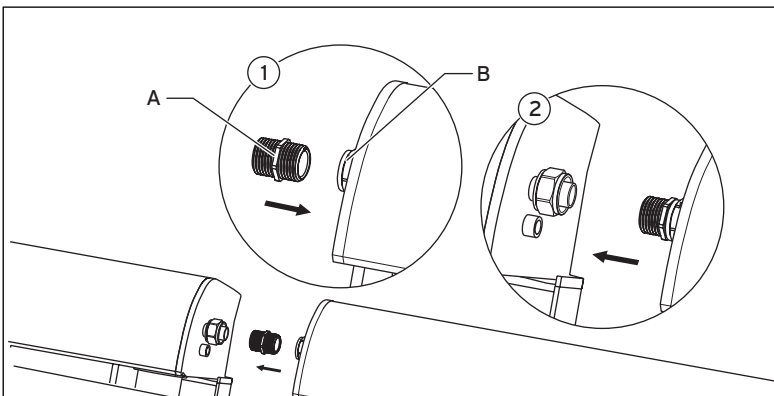

Fig. 6.13 Joining the collectors

- Couple the double nipple (**A**) (from the VTK expansion module connecting kit, Part No. 0020076779) to the union nut (**B**) on the first collector.
- Push the collectors together.

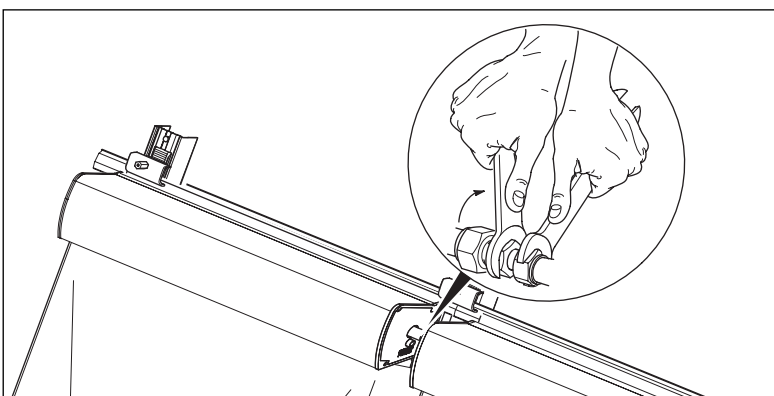

Fig. 6.14 Tightening the compression fitting

⚠ Caution!
Danger of damage to the collector as a result of incorrect assembly!
To prevent damage when tightening the compression fitting, always use a second spanner to provide a counter force.

- Tighten the two union nuts on the double nipple.

6 Flat-roof mounting

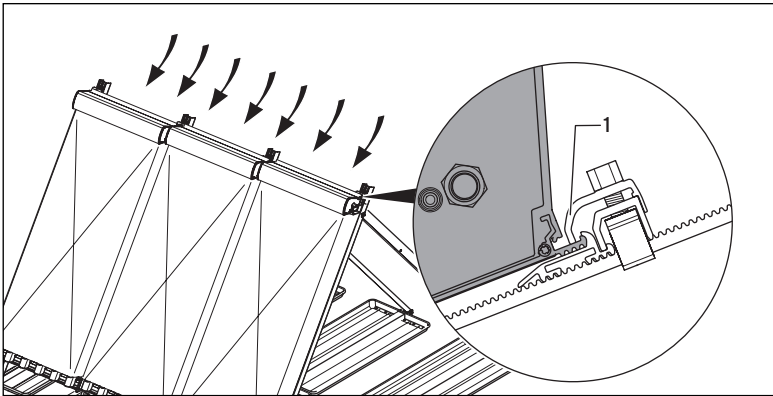

Fig. 6.15 Positioning the upper mounting rail

- Slide the upper mounting rails towards the collectors.
- Take care that the upper parts (1) of the clamping elements are over the rails on the collectors.
- Tighten the clamping element with the socket/combination wrench (13 mm AF).

Caution!
After tightening the clamping elements, make sure the tension is correct by shaking the upper part of the clamping element. If it can be moved, retighten the nut.

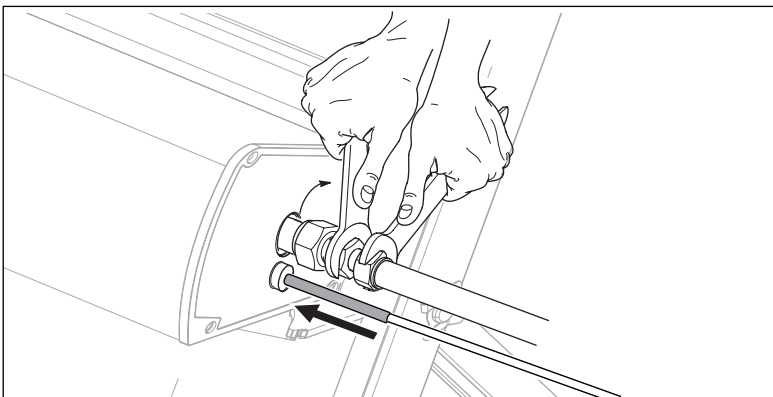

Fig. 6.16 Fitting the hydraulic connections

- **For systems with collector sensors:** Plug the collector sensor into the opening provided on the flow side of the collector (hot side).

Note
It is possible to attach the collector sensor to the left or the right side of the collector array, as the collectors have a corresponding opening on each side.
Always ensure the VR11 sensor is fitted to the hot side of the collector array.

Caution!
Danger of damage to the collector as a result of incorrect assembly!
To prevent damage when tightening the compression fitting, always use a second spanner to provide a counter force.

- Connect the collector supply and return to the system with the connection pipes.
- To do this, connect the compression fitting (from the VTK basic module connecting kit, Part No. 0020076785) to the collector and connect this to the connecting pipe.
- If necessary check the connections for leaks.

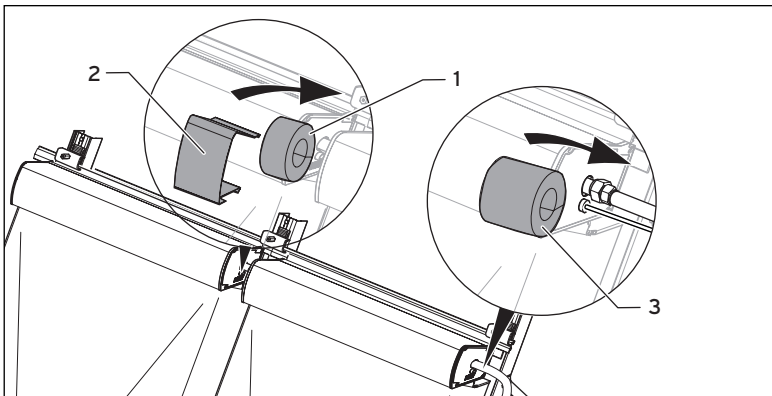

Fig. 6.17 Insulating the hydraulic connections

After commissioning:

- Insulate the hydraulic connections with the Armeflex insulation **(1)** (from the VTK expansion module connecting kit, Part No. 0020076779).
- Cover the insulation with the cover clip **(2)** (from the VTK expansion module connecting kit, Part No. 0020076779).
- Insulate the hydraulic system connections with the EPDM insulation **(3)** (from the VTK expansion module connecting kit, Part No. 0020076779).

7 Final operations

Based on the following table, make sure all work steps have been performed.

Step	
1	For flat roof installation: frames fixed with retaining pin and safety clip
2	For flat roof installation: gravel trays filled/frames anchored
3	All hydraulic connections tightened
4	Hydraulic connections laid correctly
5	VR 11 collector sensors connected (for systems with collector sensors)
6	All clamping elements tightened
7	Collectors connected to lightning protection device (optional with lightning protection device)
8	Pressure test (ideally with air pressure) carried out, all connections tight

Table 7.1 Final operations

8 Recycling and disposal

The development of all Vaillant products takes into account the future with regard to use of materials that can be easily recycled with the least detrimental affects upon our environment. The packaging makes maximum use of recycled materials and the appliance itself consists mainly of metals that are readily separated into recyclable raw materials. After many years of reliable operation our appliance can be disposed via recognised recycling and reclamation facilities in a way that will cause least harm to our environment.

9 Vaillant Customer Service and warranty

9.1 Vaillant warranty

Vaillant provides a full parts and labour warranty for this appliance.

The appliance and all associated pipe work and controls must be installed by suitably competent persons in accordance with all current and relevant safety, building control and planning regulations and in full compliance with the manufacturer's instructions.

All unvented domestic hot water cylinders must be installed by a competent person to the prevailing building regulations at the time of installation (G3).

Terms and conditions apply to the warranty, details of which can be found on the warranty registration card included with this appliance.

Failure to install and commission this appliance in compliance with the manufacturer's instructions may invalidate the warranty (this does not affect the customer's statutory rights).

9.2 Vaillant service

To ensure regular servicing, it is strongly recommended that arrangements are made for a Maintenance Agreement.

Please contact Vaillant Service Solutions (0870 6060 777) for further details.

10 Technical data

	Units	VTK 570/2	VTK 1140/2
Number of vacuum tubes		6	12
η_0 (aperture), DIN4757-4 or EN12975	%	64.2	
c_1 with wind, relative to aperture	W/(m ² k)	0.885	
c_2 with wind, relative to aperture	W/(m ² k ²)	0.001	
$K_{\theta,trans}$ (50°), relative to aperture		1	
$K_{\theta,long}$ (50°), relative to aperture		0.9	
Predicted energy gain (location Würzburg, 5m ² aperture, 300l cylinder, 4 persons)	kWh/m ² a	586	
Peak output per collector module W_{peak}	w	642	1278
Area-related heat capacity c	kJ/(m ² k)	8.3	
Volume flow (per m ² of collector surface)	l/(m ² h)	24	
Minimum volume flow in solar circuit	l/h	180	
Absolute pressure in hard vacuum	bar	10 ⁻⁵ mbar (= 10 ⁻⁸ bar)	
Absorber absorption alpha		> 93.5% (see also ITW test report)	
Absorber emission epsilon		< 6% (see also ITW test report)	
Modular dimensions (length x height x depth)	m	0.7 x 1.65 x 0.11	1.39 x 1.65 x 0.11
Gross area	m ²	1.16	2.30
Aperture surface area	m ²	1.0	2.0
Absorber surface area	m ²	1.0	2.0
Collector capacity	l	0.9	1.8
Weight	kg	19	37
Operating overpressure, max. permissible	bar	10	10
Standstill temperature, max.	°C	295	
Connection diameter, supply/return	mm	15	
Collector material		Al / Cu / Glass / Silicon / PBT / EPDM / TE	
Glass tubing material		Borosilicate 3.3	
Selective absorber coating material		Aluminium nitrite	
Glass tubing (outer dia./inner dia./wall thickness/tube length)		47 / 37 / 1.6 / 1500	
Colour (plastic parts)		Black	
Thermal shock test	ITW test number	02COL282	
Hail impact test per DIN EN 12975-2	TÜV test number	435/142448	
Type approval number		01-228-770	

Table 10.1 Technical data

VTK 570/2

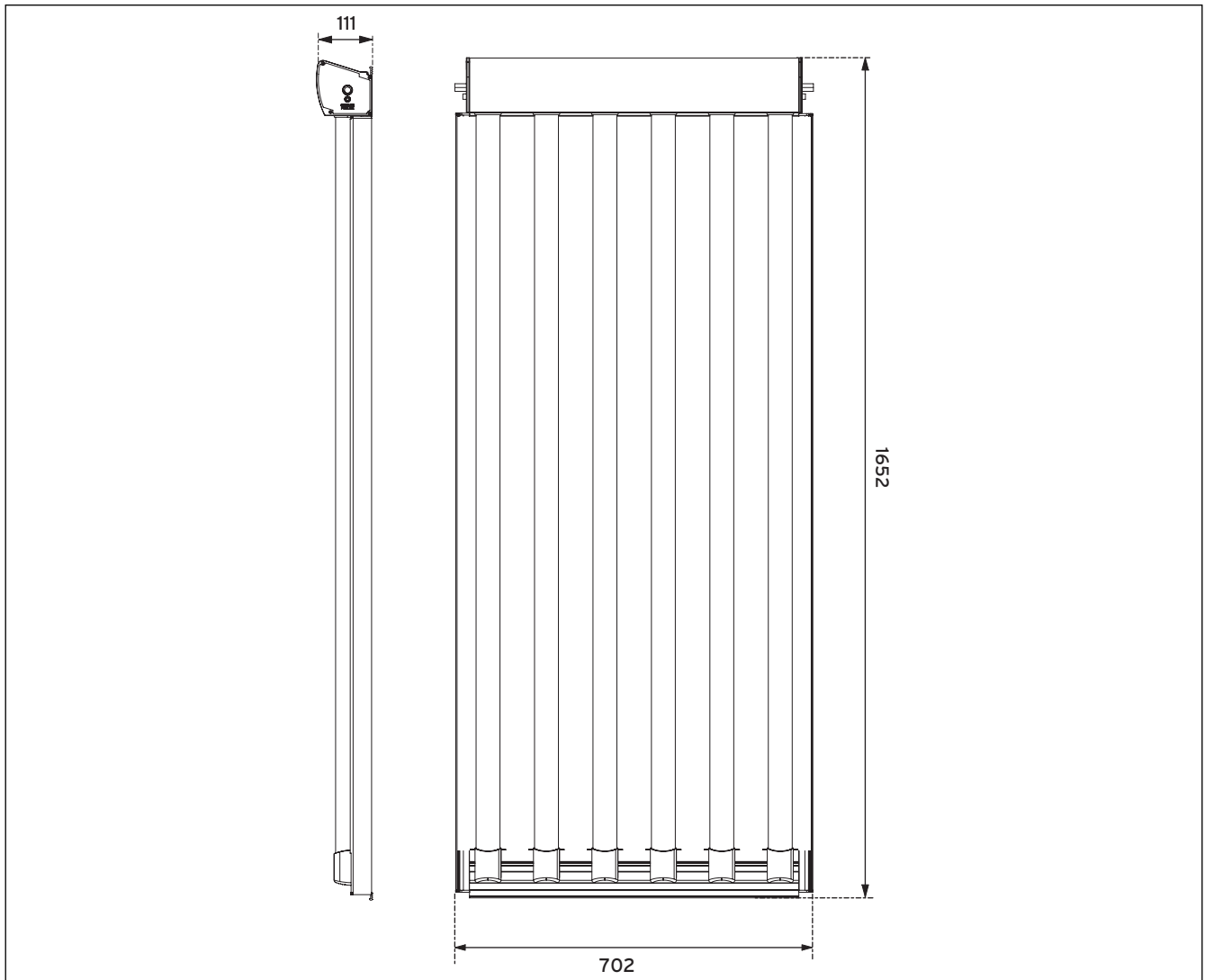

Fig. 10.1 Dimensional drawing VTK 570/2

VTK 1140/2

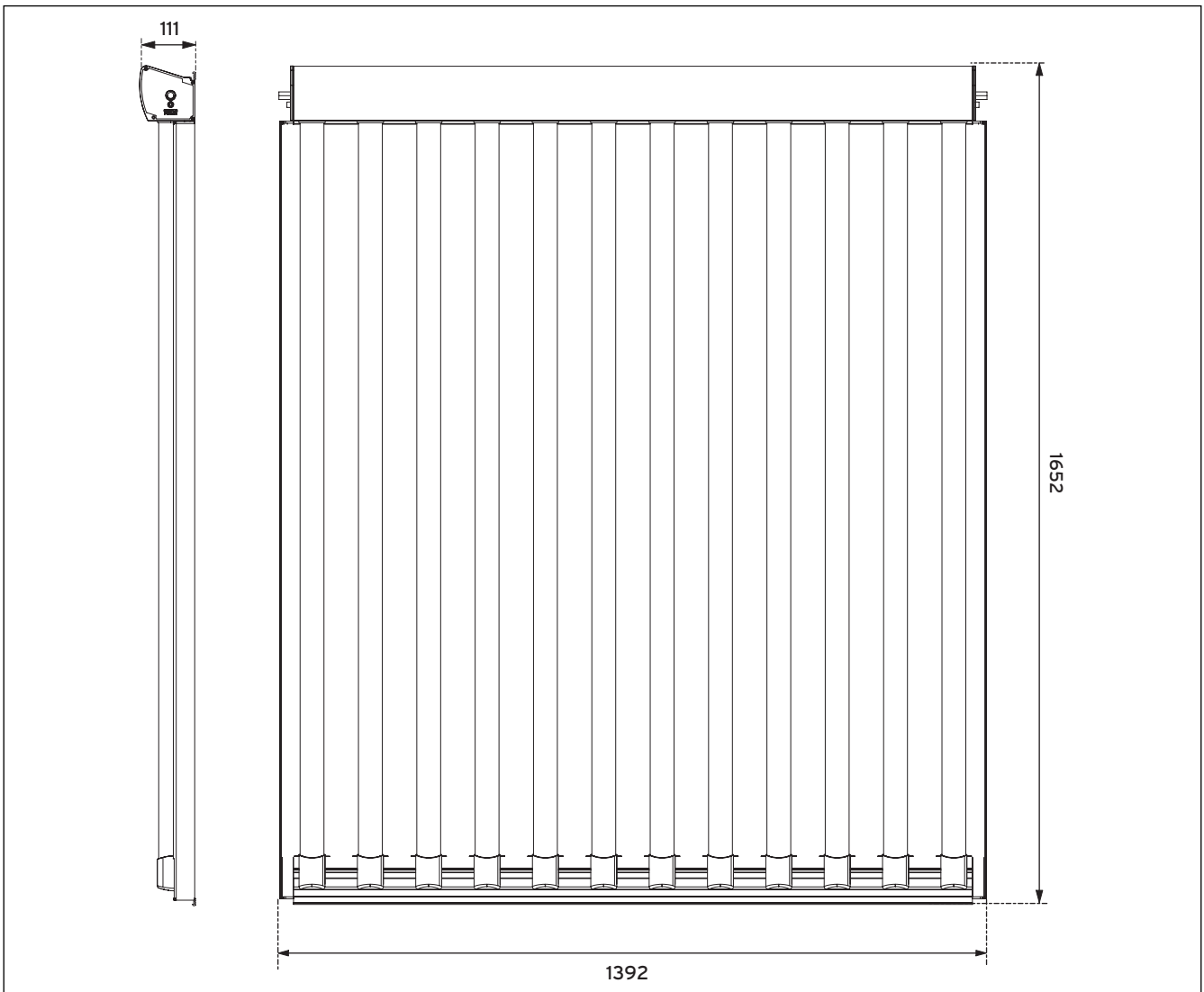

Fig. 10.2 Dimensional drawing VTK 1140/2

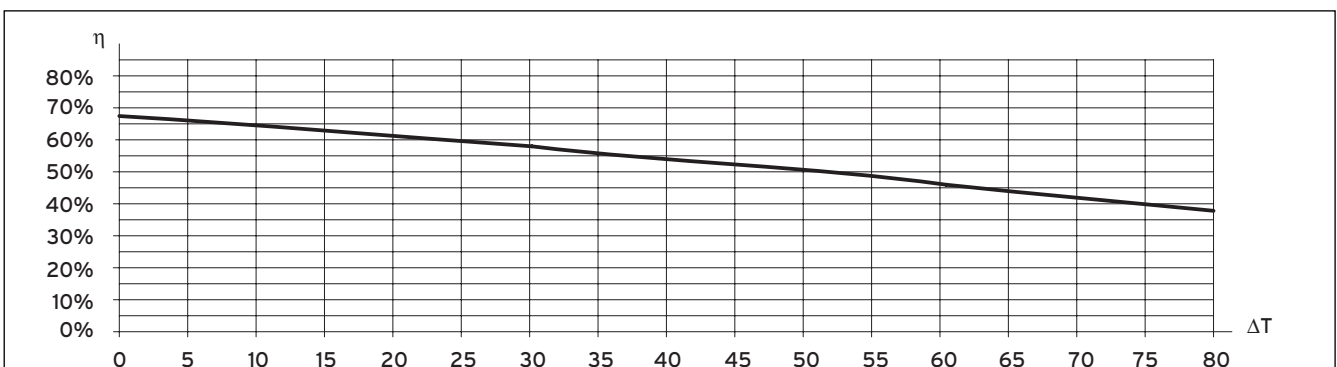

Fig. 10.3 Efficiency of the VTK 570/2 and the 1140/2 at an irradiance E_g of 300 W/m^2

Key

η Efficiency [%]

$\Delta T = T_{\text{Collector}} - T_{\text{Ambient air}}$ [K]

10 Technical data

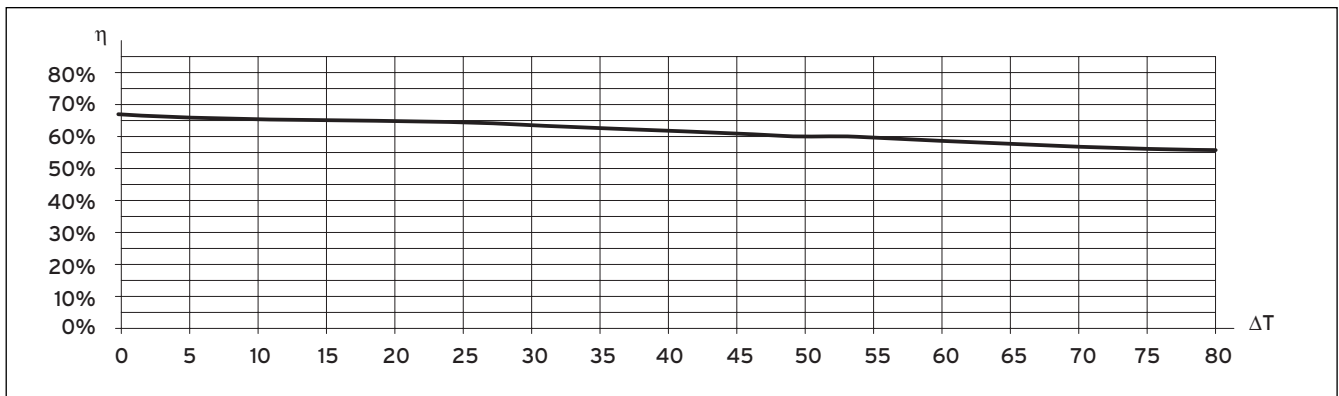

Fig. 10.4 Efficiency of the VTK 570/2 and the 1140/2 at an irradiance E_g of 800 W/m^2

Key

η Efficiency [%]

$\Delta T = T_{\text{Collector}} - T_{\text{Ambient air}}$ [K]

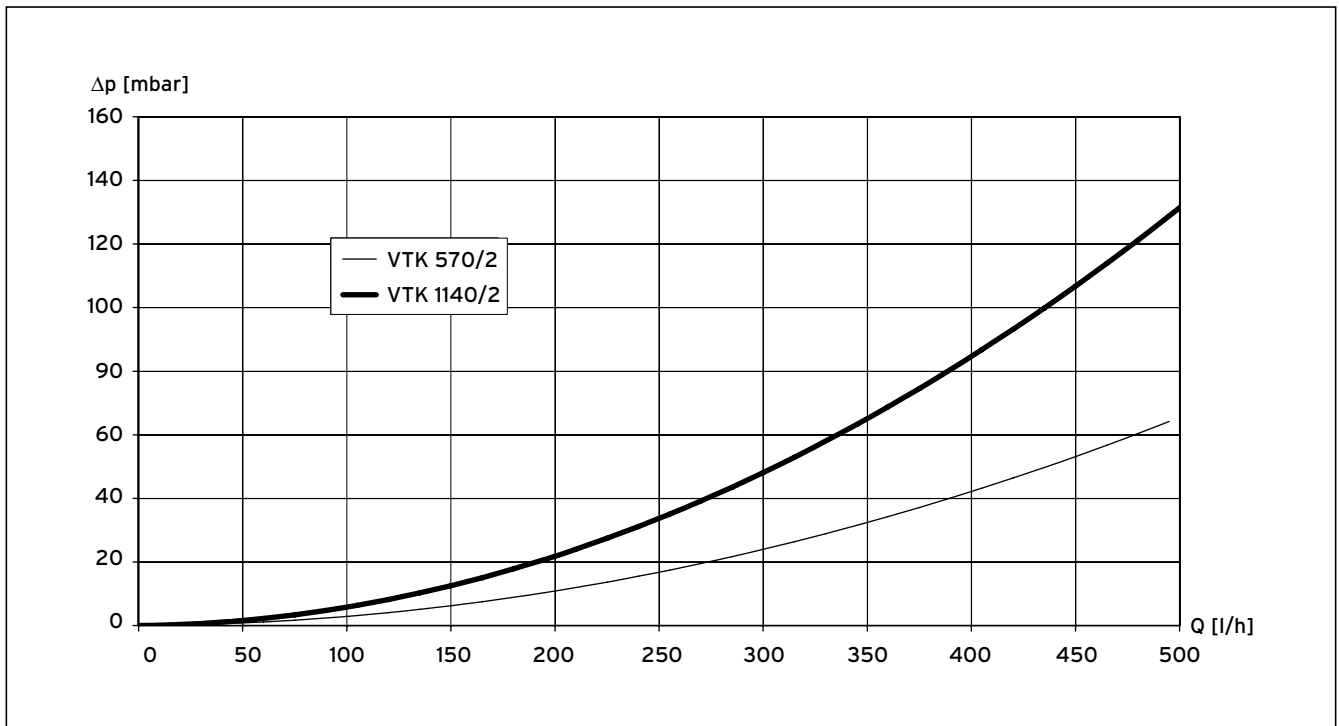

Fig. 10.5 Pressure loss graph

Key

Q Mass flow [l/h]

Δp Pressure loss [mbar]

Vaillant Ltd

Vaillant House ■ Medway City Estate ■ Trident Close ■ Rochester ■ Kent ME2 4EZ
Telephone 01634 292300 ■ Fax 01634 290166 ■ www.vaillant.co.uk ■ info@vaillant.co.uk

0020077994_00 GB 022009 - Modifications reserved