

INSTRUCTIONS FOR INSTALLATION AND SERVICING

Wall mounted COMBIcompact®

for central heating
and instantaneous
domestic hot water

Fan-assisted Room Sealed

This appliance shall be installed in accordance with the relevant Codes of Practice by British Gas or by an authorized installer (CORGI member).

These instructions should be left with the user when the installation is completed.

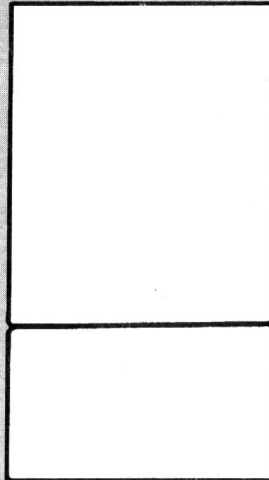

VCW GB 242 EH
GC-No. 4704413

VCW GB 282 EH
GC-No. 4704418

VCW GB 242 EB
VCW GB 282 EB



HEATING, CONTROLS, HOT WATER.

Contents

| | Page | | Page |
|------------------------------|------|------------------------------|------|
| 1 Introduction | 2 | 10 Electrical installation | 24 |
| 2 Technical data | 3 | 11 Commissioning and testing | 31 |
| 3 Construction of appliance | 4 | 12 Assembling | 35 |
| 4 Function | 5 | 13 Servicing of boiler | 37 |
| 5 General requirements | 6 | 14 Replacement of parts | 41 |
| 6 Dimensions | 14 | 15 Fault finding | 62 |
| 7 Installation of the boiler | 15 | 16 Electrical diagrams | 70 |
| 8 Delivery | 16 | 17 Short part list | 72 |
| 9 Installation sequence | 17 | 18 Technical data | 76 |



The COMBIcompact carries the 'CE' Mark. This demonstrates that the boiler fulfils the essential requirements of the Gas Appliance Directive (Directive 90 / 396 / EEC) and The Gas Appliances (Safety) Regulations 1992.

1 Introduction

The Vaillant gas-fired boiler is a wall-mounted fan-assisted room sealed appliance with built-in domestic hot water heater.

Note to Installers

The boiler can be installed on an outside or inside wall inside the building.

The boiler is **not** suitable for external installation. The air/flue duct elbow can be set to allow the air/flue duct to connect to the boiler at any angle in the horizontal plane.

Additional bends and elbows may be installed in the air flue duct. See separate flue instructions supplement.

Output ratings are shown in "Technical Data". The boiler is designed for use in a sealed water system with pumped circulation and includes the hot water system.

Contact the manufacturer for information on open vented installations.

Circulation pump, expansion vessel (for sealed system only), terminal box, control and safety devices are provided with the appliance.

This boiler does not have a pilot burner. The main burner is ignited electronically direct via two ignition electrodes and checked by means of a flame sensor.

The sealed system pressure relief valve is also provided.

An automatic system bypass is included in the boiler.

If desired an inhibitor may be used in the system. Guidance on the use of inhibitors is contained in these instructions.

The boiler contains a domestic hot water heat exchanger. The temperature in the heat exchanger is limited by the boiler control system and it is not normally necessary to install a scale reducer on the cold water mains inlet to the boiler. However, in exceptionally hard water areas to prevent scale formation in the property hot water system pipework a scale reducer may be fitted.

2 Technical Data

Subject to alteration

We cannot accept responsibility for damage as a result of non-observance of these installation and servicing instructions.

| Type | VCWGB 242 EH | VCWGB 282 EH | Units | |
|---|--|--|--|---------------------------------|
| Nominal heating output | 24 (81900) (86.4) | 28 (95500) (101) | kW (BTU/h) (MJ/h) | |
| Nominal heating input (based on gross C.V.) | 29.6 (101030) (106.6) | 35 (119500) (126) | kW (BTU/h) (MJ/h) | |
| Main burner jet size for NG | 16 x 7/140 | 16 x 7/140 | number x mark. | |
| Burner setting pressure Max rate Ignition rate | 5.1 (2.05) 1.5 (0.6) | 6.8 (2.73) 0.6 (0.2) | mbar (in wg) | |
| Minimum water flow for heating system 20°C rise | 1030 (227) | 1200 (265) | l/h (Imp. Gal./h) | |
| Water capacity of heat exchanger | 0.57 (0.12) | 0.57 (0.12) | l (Imp. Gal.) | |
| Pump pressure available for central heating system | 0.25 (8.4) | 0.25 (8.4) | bar (feet) | |
| Max. nominal flow temperature | 90 (194) | 90 (194) | °C (°F) | |
| Maximum total water capacity of heating system (cold ¹⁾) for sealed system | 90 (20) | 90 (20) | l (Imp. Gal.) | |
| Delivered gas Gross C.V. (s.t.) Gas consumption (s.t.) | G 20 37.8 (1014) 2.82 (1.66) | G 20 37.8 (1014) 3.33 (1.96) | MJ/m ³ (BTU/cu. ft) m ³ /h (c.f.m.) | |
| Domestic waterspecification to British standard Nominal output | 24 (81900) | 28 (95500) | kW (BTU/h) | |
| Nominal temperature Minimum water pressure Flow rate (45°C) | 65 (149) 0.65 (9.4) 10.0 (2.2) | 65 (149) 0.65 (9.4) 11.4 (2.5) | °C (°F) bar (P.S.I.) l/min. (gal/min.) | |
| D.H.W. temp. rise ²⁾ 10 l/min. (2.2 gal/min.) flow rate, approx. water pressure required | 35 1.6 (23.2) | 40 1.6 (23.2) | (°C) bar (P.S.I.) | |
| Water flow min. Water pressure required Max. water pressure | 3.5 (0.77) 0.3 (4.4) 10 (145) | 3.5 (0.77) 0.3 (4.4) 10 (145) | l/min. (gal/min.) bar (P.S.I.) bar (P.S.I.) | |
| Weight | 61.5 (136) | 61.5 (136) | kg (pound) | |
| Electric connection | Voltage Input external Fuse internal Fuse | 230-240/50 135 3 0.16/2 | 230-240/50 180 3 0.16/2 | V~/Hz W Amp Amp (slow) |

¹⁾ For systems having a larger water capacity an additional expansion vessel can be installed easily.

²⁾ Higher DHW temp. rises can be achieved by adjusting the user selector (See user instructions).

3 Construction of appliance

- 1 Air/flue elbow*
- 4 Combustion chamber
- 6 Gas control unit with operator
- 7 N/A
- 9 Circulating pump
- 10 Hydraulically controlled diverter valve
- 11 Pressure gauge
- 12 Flow thermometer
- 17 Terminal box electric system
- 18 Flow temperature selector
- 19 Fuses F 2A
- 20 Heat exchanger domestic hot water
- 21 Lock-out reset switch
- 22 Lock-out red neon
- 23 Heating switch
- 24 Main switch

* The elbow is supplied together with the accessory No. 9023 (air/flue duct).

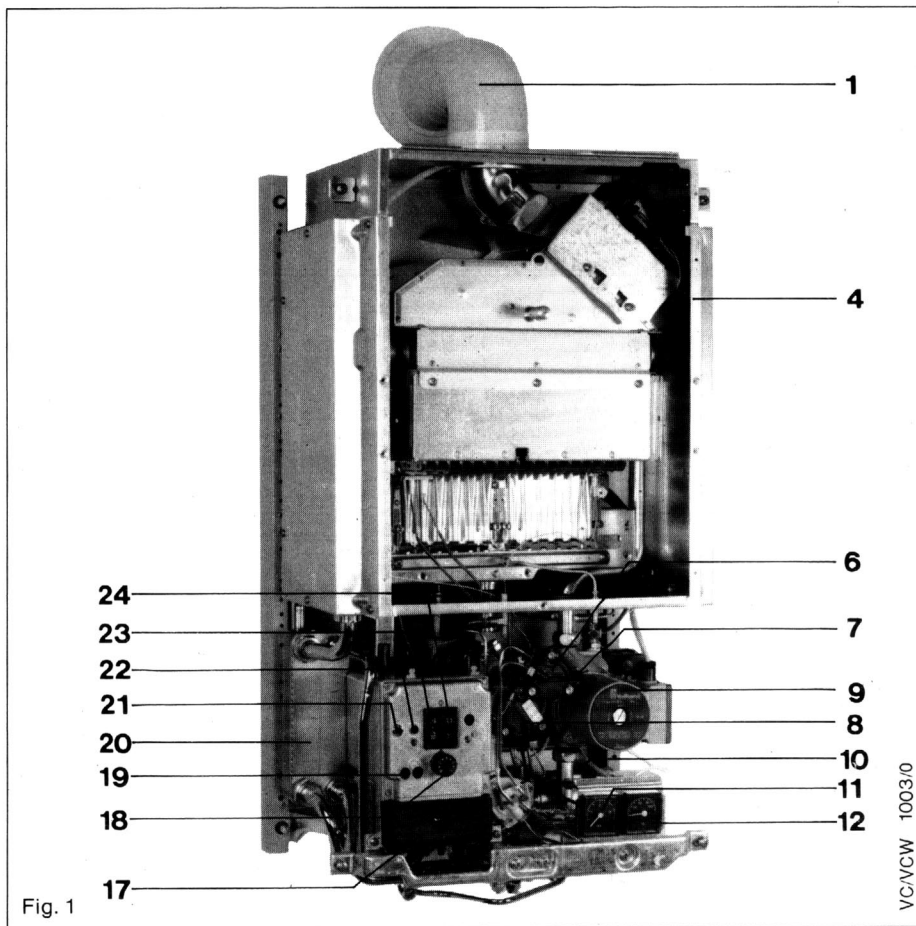

Fig. 1

VC/VCW 1003/0

4 Function

- 1 Flue gas duct
- 2 Air duct
- 3 Main heat exchanger
- 4 Venting point
- 5 Combustion chamber
- 6 Automatic air vent
- 7 Flame sensor electrode
- 8 Burner
- 9 Gas section
- 10 Gas operator
- 11 C.H. expansion vessel pressure test point
- 12 C.H. expansion vessel
- 13 Circulating pump
- 14 Hydraulically operated diverter valve
- 15 C.H. pressure relief valve
- 16 Water section
- 17 Water section diaphragm
- 18 D.H.W. cold supply
- 19 Gas service cock
- 20 C.H. return service cock
- 21 C.H. system
- 22 C.H. flow service cock
- 23 Gas supply
- 24 D.H.W. outlet
- 25 System bypass
- 26 Servo control valve
- 27 Not applicable
- 28 Electronic control box
- 29 D.H.W. heat exchanger
- 30 Ignition electrodes
- 31 Not applicable
- 32 N.T.C. flow sensor
- 33 Overheat cut off sensor
- 34 Differential valve
- 35 D.H.W. expansion vessel
- 36 Air pressure switch
- 37 Fan
- 38 C.H. thermostat
- 39 D.H.W. thermostat

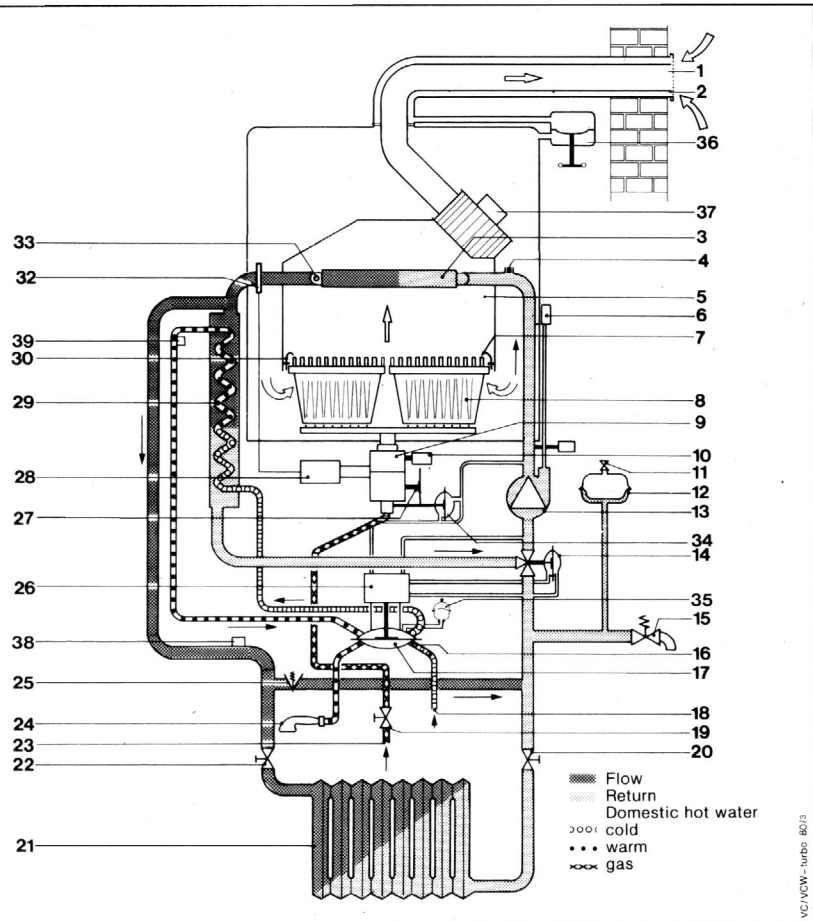

Fig. 2

5 General requirements

5.1 Related documents

The installation of the boiler must be in accordance with the relevant requirements of Gas Safety (Installations and Use) Regulation 1994*, current I.E.E. Wiring Regulations, Health and Safety Document No. 635 "The Electricity at work Regulations 1989", and the by-laws of the local Water-Undertaking. It should be in accordance with any relevant requirements of the Local Authority, Building Regulations, Building Standards (Scotland) Regulations and the relevant recommendations of the following British Standard Codes of Practice:

- BS 5440: Flues a ventilation of gas fired boilers not exceeding 60 kW:
 - Part 1: Flues
 - Part 2: Ventilation
- BS 5449 Specification for forced circulation hot water for domestic premises.
- BS 5546: Specification for gas hot water supplies for domestic premises.
- BS 6700: Services supplying water for domestic use within buildings and their curtilages.
- BS 6798: Specification for installation of gas fired boilers not exceeding 60 kW input.
- BS 6891: Specification for installation of low pressure gas pipework up to 28 mm (R1) in domestic premises (2nd family gas).
- BS 7593: Treatment of water in domestic hot water central heating systems.
BRITISH GAS PUBLICATION DM2:
Guide for Installation in
Timber Framed Housing.

Unvented primary circuits may be filled or replenished by means of a temporary connection between the circuit and a supply pipe provided a double check valve or some other no less effective backflow prevention device is permanently connected at the inlet to the circuit and the temporary connection is removed after use.

*) Gas Safety (Installation and use) Regulation, 1994:

It is the law that all gas appliances are installed by competent persons, in accordance with the above regulations. Failure to install appliances correctly could lead to prosecution. It is in your own interest, and that of safety, to ensure that the law is complied with.

5.2 Location

The location chosen for the boiler must permit the provision of a satisfactory flue termination. The location must also provide adequate space for servicing and air circulation around the heater. The boiler may be installed in any room, although particular attention is drawn to the requirements of the I.E.E. Regulations and, in Scotland, the electrical provisions of the building regulations, in respect of the installation of the boiler in a room containing a bath or shower.

Note: Where a room sealed appliance is installed in a room containing a bath or shower, any electrical switch or appliance control utilising mains electricity should be so situated that it cannot be touched by a person using the bath or shower.

Where the installation of the boiler will be in an unusual location, special procedures may be necessary and BS 5546 and BS 6798 give detailed guidance on this aspect.

A compartment used to enclose the boiler must be designed and constructed specifically for this purpose. An existing cupboard or compartment may be used provided that it is modified for the purpose.

Details of essential features of cupboard/-compartment design including airing cupboard installations are given in BS 6798.

5.3 Gas supply

The local gas supplier should be consulted at the installation planning stage in order to establish the availability of an adequate supply of gas.

An existing service pipe must not be used without prior consultation with the local gas supplier.

A gas meter is connected to the service pipe by the local gas supplier or their contractor.

An existing meter should be checked to ensure that it is capable of passing an additional 2.82 m³/h (99.6 ft³/h) before the VCW GB 242EH and 3.33 m³/h (117.6 ft³/h) before the VCW GB 282EH is installed.

Installation pipes should be fitted in accordance with BS 6891.

Pipework from the meter to the boiler must be of an adequate size. Do not use pipes of a smaller size than the boiler gas connection. The complete installation must be tested for soundness and purged as described in BS 6891.

5.4 Electrical supply

Wiring external to the boiler must be installed in accordance with the current I.E.E. Regulations and any local regulations which apply.

The boiler is supplied for connection to a 230 V~, 50 Hz. Fuse rating is 3 A.

This appliance must be earthed. The method of connection to the mains electricity supply must provide a means of completely isolating the boiler and its ancillary controls. Isolation is preferably by the use of a fused three-pin plug and unswitched shuttered socket outlet, both complying with the requirements of BS 1363. Alternatively, a 3 Amp. fused doublepole switch with a 3 mm contact separation on both poles may be used.

5.5 Flue system

Detail recommendations for flueing are given in BS 5440:1. The following notes are intended to give general guidance.

The air/flue duct and terminal assembly can be completely assembled from the inside of the building.

1. The terminal must be positioned such that the combustion products can disperse freely at all times.
2. In certain weather conditions a terminal may steam (high efficiency appliance) and positions where this could cause nuisance should be avoided.
3. If the terminal is fitted within 1000mm of a plastic or painted gutter or within 500mm of painted eaves an aluminium shield of at least 1000mm length should be fitted to the underside of the gutter or painted surface.
4. The air inlet/products outlet duct and the terminal of the boiler must not be closer than 25mm (1 in.) to combustible material. Detailed recommendations on protection of combustible material are given in BS 5440:1.
5. If the terminal is fitted less than 2m above a balcony, above ground or above a flat roof to which people have access then a suitable guard must be provided and fitted.

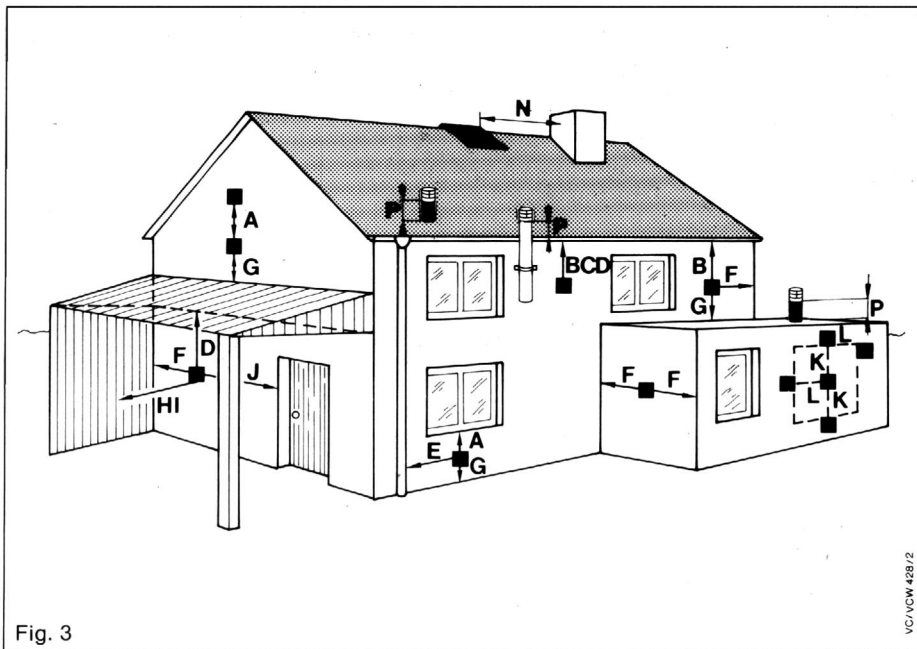

Fig. 3

Terminal position for fan-assisted flue

| | (minimum distance) | mm | | mm | |
|---|---|------|---|--|------|
| A | — Directly below an openable window or other opening (eg air brick) | 300 | J | — From an opening in the car port (e.g. door window) into dwelling | 1200 |
| B | — Below gutters, soil pipes or drain pipes | 75 | K | — Vertically from a terminal on the same wall | 1500 |
| C | — Below eaves | 200 | L | — Horizontally from a terminal on the same wall | 300 |
| D | — Below balconies or car port roof | 200 | M | — From the wall on which the terminal is mounted | N/A |
| E | — From vertical drain pipes and soil pipes | 75 | N | — From a vertical structure on the roof | N/A |
| F | — From internal or external corners | 300 | P | — Above intersection with roof | N/A |
| G | — Above ground or balcony level | 300 | | | |
| H | — From a surface facing a terminal | 600 | | | |
| I | — From a terminal facing a terminal | 1200 | | | |

5.6 Air supply

Detailed recommendations for air supply are given in BS 5440:2. The following notes are intended to give general guidance.

The fan-assisted room sealed boiler does not require the room or internal space to have a permanent air vent.

5.6.1 Cupboard or compartment air supply

Where the boiler is to be installed in a cupboard or compartment, permanent air vents are required for cooling purposes at high and low level. These air vents must either communicate with the room or internal space or be direct to outside air.

The minimum effective areas of the permanent air vents required in the cupboard or compartment are specified below.

Note: Both air vents must communicate with the same room or internal space or must be both on the same wall to the outside air.

5.7 Water circulation system

Detailed recommendations for the water circulation system are given in BS 6798, and BS 5449:1 (for small bore and micro bore central heating systems). The following notes are of particular importance. Pipework not forming part of the useful heating surface should be insulated to help prevent heat loss and possible freezing, particularly where pipes are run through roof spaces and ventilated underfloor spaces.

Draining taps must be located in accessible positions which permit the draining of the whole system including the boiler and the hot water system. Draining taps should be at least ½ in. BSP nominal size and be in accordance with BS 2879.

| air appliance | | VCWGB | VCWGB |
|---------------|---------------------------------|---|---|
| vent position | | 242 EH | 282 EH |
| High level | Air from room or internal space | 268 cm ² 42 in ² | 317 cm ² 50 in ² |
| | Air direct from outside | 134 cm ² 21 in ² | 159 cm ² 25 in ² |
| Low level | Air from room or internal space | 268 cm ² 42 in ² | 317 cm ² 50 in ² |
| | Air direct from outside | 134 cm ² 21 in ² | 159 cm ² 25 in ² |

The boiler is suitable for use with minibore or microbore systems.

It is recommended to use copper tubing to BS 2871:1 for water carrying pipework.

The use of horizontal pipe runs should be avoided wherever possible in order to prevent air collecting in the system. If horizontal runs are unavoidable the pipes should rise upwards towards a vent point.

For general guidance reference should be made to the British Gas publication.

— BRITISH GAS SPECIFICATIONS FOR DOMESTIC WET CENTRAL HEATING SYSTEMS — and to BS 6798 and BS 5449:1.

Particularly where a new boiler is to be fitted to an existing system, it is good practice that the system is thoroughly cleansed. This cleansing should take place prior to the fitting of the new boiler and be in accordance with BS 7593.

For advice on the application of system cleansers contact Sentinel, Grace Dearborn Ltd., Widnes, Cheshire, WA8 8uD.

Tel.: 0151 495 1861.

5.7.1 Single pipe system (Fig. 4)

The heat emitters are installed on a closed circuit. The necessary water quantity for every heat emitter (radiator) must be ensured. This can be done for instance by using suction fittings in the return connection of the radiators. The radiator sizes shall be calculated on the basis of temperature distribution around the circuit.

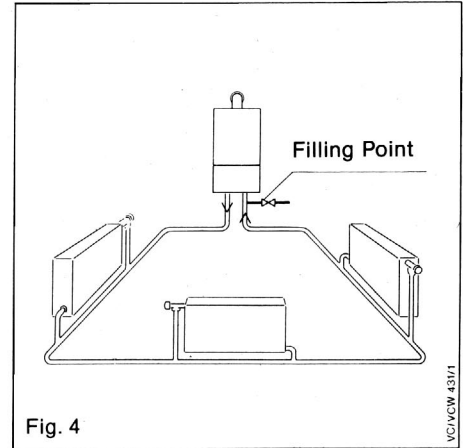

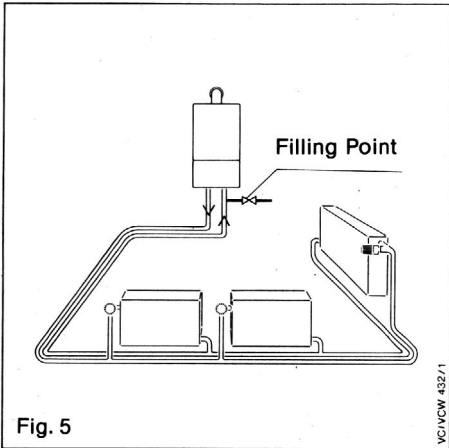

N.B. The primary filling point may be placed at any convenient point on the circuit.

5.7.2 Two-pipe system (Fig. 5)

The radiators are installed parallel and the flow temperature therefore is the same for every radiator.

A typical central heating installation is shown in figure 5.

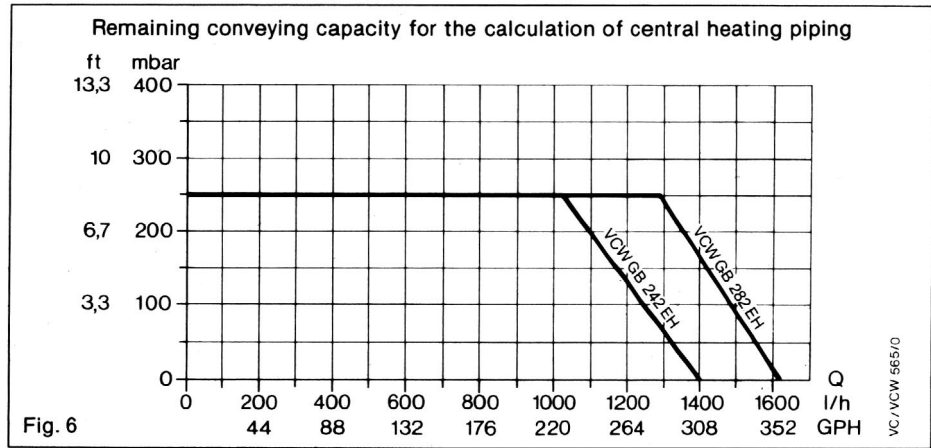

5.8 Circulating pump

The circulating pump is included into the boiler. The remaining conveying capacity can be taken from the diagram (Fig. 6).

5.9 System by-pass

A system by-pass is included within the boiler. The boiler is suitable for use in systems with thermostatic radiator valves and no additional by-pass is required.

5.10 Open vented system

Refer to manufacturers for further details.

5.11 Sealed systems

Sealed systems do not require feed and expansion cisterns, open vents etc. Only good quality radiator valves and fittings should be used in order to prevent excessive detrimental topping-up.

5.11.1 Pressure relief valve

A pressure relief valve is provided ready-assembled to the return C.H. service cock (4, fig. 15). This safety device is required on all sealed C.H. systems and is pre-set at 3 bar and is provided with 3/4 in. BSP connection for a discharge pipe.

5.11.2 Pressure gauge

This is factory fitted to the boiler and indicates the primary circuit pressure to facilitate filling and testing.

5.11.3 Expansion vessel

An expansion vessel is incorporated into the boiler suitable for a sealed heating system with a maximum water contents of 90 litres (20 Imp. galls.).

If the nominal capacity of the built-in expansion vessel is not sufficient for the heating system (for instance in case of modernization of old open systems) an additional expansion vessel can be installed external to the appliance in the return pipe as close as possible to the boiler in accordance with BS 5449: Part 1.

Guidance on the sizing of additional expansion vessel sizing is given in Table A (p. 13).

5.12 Filling and make up (fig. 7)

The system should be filled with water via a separate filling point fitted at a convenient point on the heating circuit. Where local Water Authority Regulation allows, a temporary

connection to the mains may be used. The connection must be removed when filling is completed. Where local Water Authority Regulation does not allow temporary connection, a sealed system filler pump with break tank must be used. **The heating system will not be filled automatically from the domestic side.**

In principle, sealed systems do not require water make-up facilities, but experience has shown that some make-up may be necessary. Methods of filling sealed systems are given in appendix A of BS 6798 and BS 5449: Part 1.

5.13 Parallel installation

If two appliances are installed in parallel for one heating system, it is essential to install one nonreturn valve each in the heating system flow pipe of the appliances.

Refer to manufacturers for further details.

5.14 Gas and water connection

A general view of pipework for gas and water connection is given in Fig. 8.

The wall distance (to the finished wall) of pipework for gas and heating system is 50 mm and 35 mm for domestic water pipework.

5.15 Venting

The appliance is fitted with an automatic air vent. Additional provision should be made to enable the heating system to be vented during filling and commissioning either by automatic air vents or manually. Hydroscopic types of automatic air vents should not be used on a sealed system as these allow evaporation of small quantities of water.

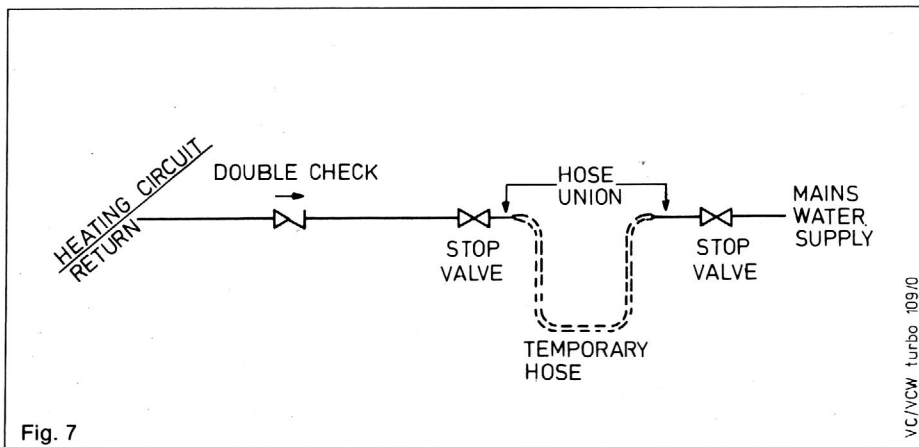
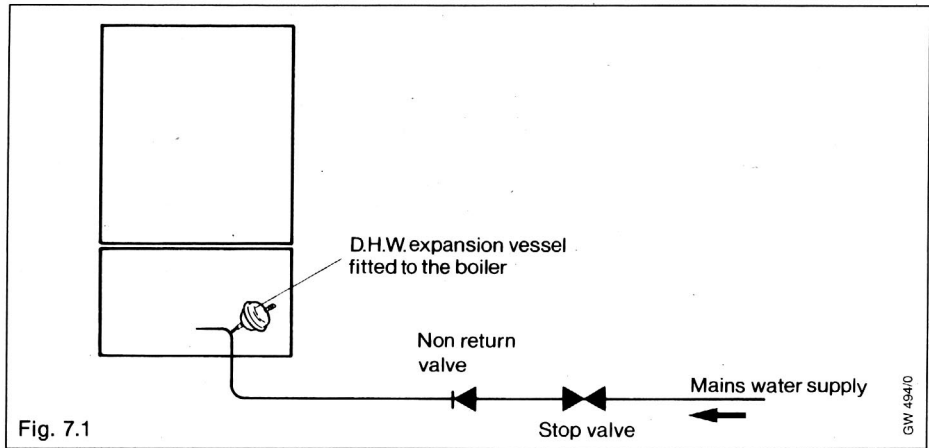

Fig. 7

5.16 DHW expansion vessel accessory

A DHW expansion vessel kit is available as an optional extra from Vaillant Ltd. This expansion vessel kit should be fitted to the boiler whenever either a stop valve of the loose jumper type or a non return valve are present in the cold water mains supply to the boiler (fig. 7.1).



- 1 Connection support bracket
- 2 Service cock (flow of heating system)
- 3 Domestic hot water connection
- 4 Compression Union (gas)
- 5 Gas service cock (supplied with the boiler)
- 6 Cold water connection with shut-off valve
- 7 Service cock (return of heating system)
- 8 Discharge pipe
- 9 Pressure relief valve
- 10 Compression union (return of heating system)
- 11 Compression union (flow of heating system)
- 23 Frame of appliance (lower connection)

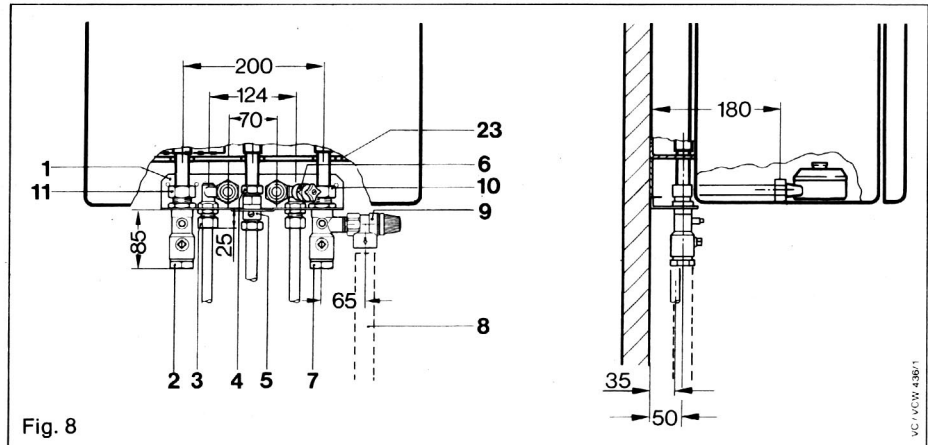

Sizing of additional expansion vessels:

| Safety valve setting (bar) | 3,0 | | | | | | | | |
|--|----------------------------------|-------|-------|-------|-------|-------|-------|-------|-------|
| Vessel charge pressure (bar) | 0,5 | | | | 1,0 | | | 1,5 | |
| Initial system pressure (bar) | 0,5 | 1,0 | 1,5 | 2,0 | 1,0 | 1,5 | 2,0 | 1,5 | 2,0 |
| Total water content of system | Expansion vessel volume (litres) | | | | | | | | |
| litres | | | | | | | | | |
| 25 | 2,1 | 3,5 | 6,5 | 13,7 | 2,7 | 4,7 | 10,3 | 3,9 | 8,3 |
| 50 | 4,2 | 7,0 | 12,9 | 27,5 | 5,4 | 9,5 | 20,6 | 7,8 | 16,5 |
| 75 | 6,3 | 10,5 | 19,4 | 41,3 | 8,2 | 14,2 | 30,9 | 11,7 | 24,8 |
| 100 | 8,3 | 14,0 | 25,9 | 55,1 | 10,9 | 19,0 | 41,2 | 15,6 | 33,1 |
| 125 | 10,4 | 17,5 | 32,4 | 68,9 | 13,6 | 23,7 | 51,5 | 19,5 | 41,3 |
| 150 | 12,5 | 21,0 | 38,3 | 82,6 | 16,3 | 28,5 | 61,8 | 23,4 | 49,6 |
| 175 | 14,6 | 24,5 | 45,3 | 96,4 | 19,1 | 33,2 | 72,1 | 27,3 | 57,9 |
| 200 | 16,7 | 28,0 | 51,8 | 110,2 | 21,8 | 38,0 | 82,4 | 31,2 | 66,2 |
| 225 | 18,7 | 31,5 | 58,2 | 124,0 | 24,5 | 42,7 | 92,7 | 35,1 | 74,5 |
| 250 | 20,8 | 35,0 | 64,7 | 137,7 | 27,2 | 47,5 | 103,0 | 39,0 | 82,7 |
| 275 | 22,9 | 38,5 | 71,2 | 151,5 | 30,0 | 52,2 | 113,3 | 42,9 | 91,0 |
| 300 | 25,0 | 42,0 | 77,7 | 165,3 | 32,7 | 57,0 | 123,6 | 46,8 | 99,3 |
| 325 | 27,0 | 45,5 | 84,1 | 179,1 | 35,7 | 61,7 | 133,9 | 50,7 | 107,6 |
| 350 | 29,1 | 49,0 | 90,6 | 192,8 | 38,1 | 66,5 | 144,2 | 54,6 | 115,8 |
| 375 | 31,2 | 52,5 | 97,1 | 206,6 | 40,9 | 71,2 | 154,5 | 58,5 | 124,1 |
| 400 | 33,3 | 56,0 | 103,6 | 220,4 | 43,6 | 76,0 | 164,8 | 62,4 | 132,4 |
| 425 | 35,4 | 59,5 | 110,1 | 239,2 | 46,3 | 80,7 | 175,1 | 66,3 | 140,7 |
| 450 | 37,5 | 63,0 | 116,5 | 247,9 | 49,0 | 85,5 | 185,4 | 70,2 | 148,9 |
| 475 | 39,6 | 66,5 | 123,0 | 261,7 | 51,8 | 90,2 | 195,7 | 74,1 | 157,2 |
| 500 | 41,6 | 70,0 | 125,9 | 275,5 | 54,5 | 95,0 | 206,0 | 78,0 | 165,5 |
| For system volumes other than those given above, multiply the system volume by the factor across | 0.0833 | 0.140 | 0.259 | 0.551 | 0.109 | 0.190 | 0.412 | 0.156 | 0.331 |

The volume of the expansion vessel found from the above table, should be multiplied by 0,9 to take into account the flow temperature.

6 Dimensions

(all dimensions in mm)

- 1a Air/flue duct to the rear
- 1b Air/flue duct to the side
- 2 Appliance bracket
- 3 Heating system return 3/4" Rp (3/4" B.S.P.)
- 4 Cold water connection (15 mm)
- 5 Gas connection (VCW 242 = 15 mm; VCW 282 = 22 mm)
- 6 Hot water connection (15 mm)
- 7 Heating system flow 3/4" Rp (3/4" B.S.P.)
- 8 Inlet bushings in the terminal box for external connections
- 9 Compartment with terminal block
- 10 Wall outlet for electrical connections
- 11 N/A
- 12 Pre-assembled connection set with service cocks (flow and return) pressure relief valve, cold and hot water connection
- 13 Pressure relief valve 3/4" Rp (3/4" B.S.P.)

- 1) Max 995 mm without extension
- Max 1960 mm with one extension
- Max 2920 mm with two extensions.

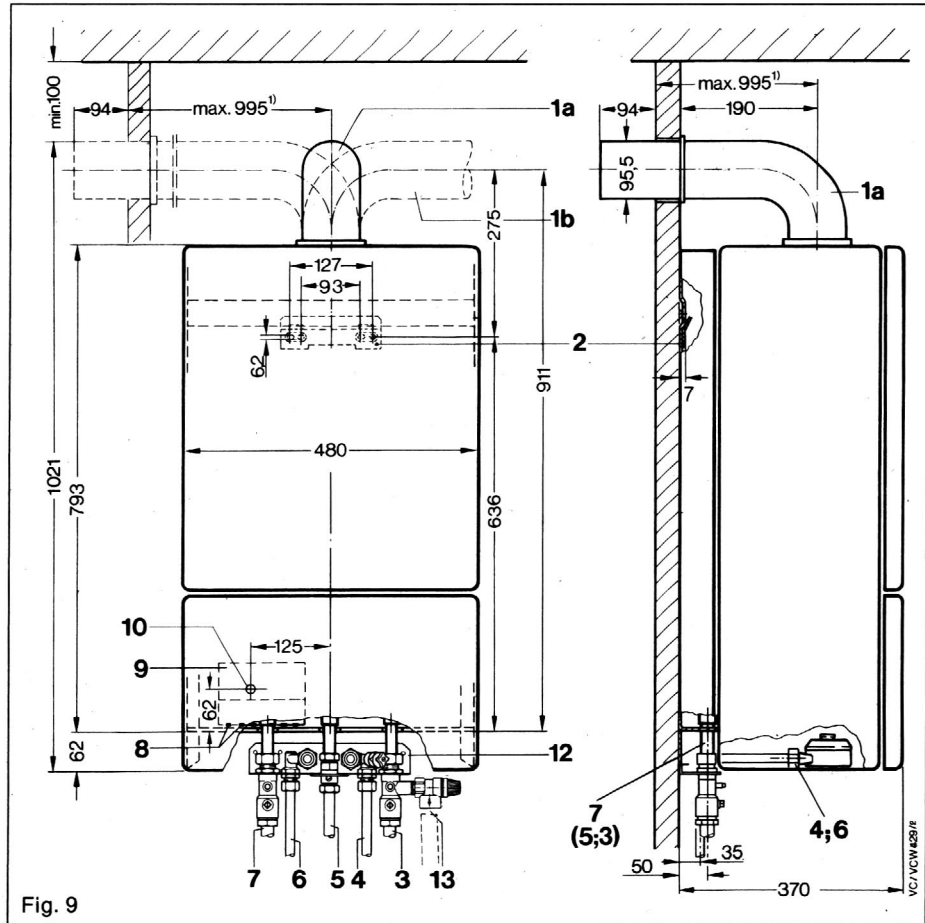

7 Installation of the boiler

7.1 General

The boiler is to be wall-mounted and a vertical flat area of wall is required which must be of sufficient area for the boiler together with clearances for installation and servicing.

The template provided includes these clearances which are:

80 mm (3.2in.) either side of the boiler

Note: A clearance of 25 mm either side of the boiler will allow the safe and correct functioning of the appliance and also allow all servicing and repair operations except for the replacement of the main heat exchanger. The replacement of this component will require a side clearance of 80 mm either side of the boiler which may be catered for by allowing removal of kitchen units etc.

150 mm (6 in.) below the boiler
265 mm (10.5 in.) on top of the boiler





Additional clearances than those given above may be necessary for installation, as this varies from site to site, it is left to the discretion of the installer.

If the appliance is to be fitted on a wall of combustible material, the wall must be protected by a sheet of fire proof material.

In addition, a minimum clearance of 500 mm (20 in.) must be available at the front of the appliance to enable the combi boiler to be serviced.

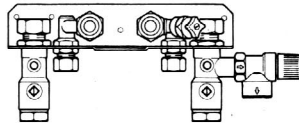
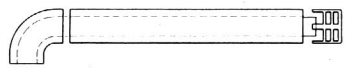
IMPORTANT NOTICE

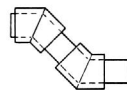
If the boiler is to be fitted in a timber framed building it should be fitted in accordance with the British Gas publication 'Guide for Gas Installations in Timber Frame Housing'. Reference DM2. If in doubt advice must be sought from the Local Gas Region of British Gas.

| Accessories | Order no. | |
|---|------------|---|
| 1) Pre-assembled connection group incl. isolating valves (flow and return), pressure relief valve, cold and hot water connections | 9313 |  |
| 2) Air/flue duct assembly incl. terminal | 9023 |  |
| Optional Extras | Order No. | |
| 3) Extension (appr. 1 m) for the standard air/flue duct assembly (optional extra) | 9338 |  |
| 4) Additional 90° elbow | 9293 |  |
| 5) Additional 45° bends (pair) | 9020 |  |
| 6) Additional air/flue duct joint clamps (pair) | 9307 |  |
| 7) Terminal guard Fig. 10 | 9308 GB |  |

7.2 Installation accessories

The connection accessories for the connection of the boiler are listed in the fig. 10.

Should the terminal of the air/flue duct assembly need to be protected by a terminal guard, a suitable guard is available from Vaillant Ltd. (Art. No. 9308 GB).

8 Delivery

The Vaillant boiler is delivered in three packages:

the cased boiler (item 1, fig 11).
pre-assembled installation set
(order-no.: 9313) and
the flue duct/terminal assembly
(order-no.: 9023)

The foam packing shells (2) contain the following:

- a) Upper front panel (3)
- b) Door panel (4) and screen plate (4a)
- c) Paper template (5)
- d) Installation instructions and user instructions (6)
- e) Gas service cock
- f) Wall bracket with fixing screws, wall plugs and 2 x 22 mm nuts and olives
- g) The appliance (7)

Note: Lift boiler by the appliance frame not by the air/flue duct aperture.

Check on the data plate (8) the appliance is the correct model for the gas supply.

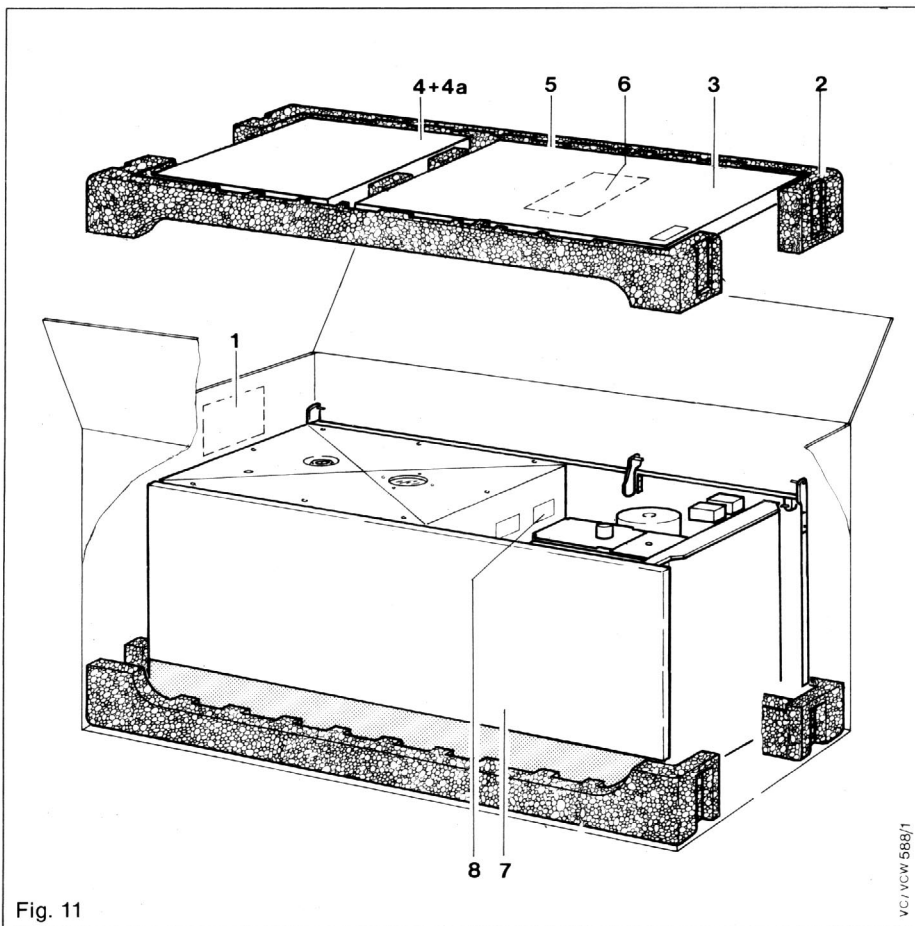

9 Installation sequence

Using the template (fig. 12)

- Fix the template onto the selected position.

Check with a plumb line that the centre-line (Q) of the template used is vertical. The template shows the appliance with necessary clearance around for servicing and air circulation.

Before proceeding check the following:

- a) the necessary air/flue duct length is in accordance with the installation options in section 1 of the instructions packed with the air/flue duct assembly.
 - b) the resulting terminal position is in accordance with section 5.5.
- Mark the position of the centre of flue duct (1) e.g. by drilling through. In the case of an installation with the air/flue duct to the rear of the appliance, mark the circumference of the hole, too.
 - Drill two holes (2) out of four fixing the appliance bracket as marked on the template with 8 mm (5/16 in.) diameter.
 - Drill three holes with 8 mm (5/16 in.) diameter (3) out of seven to fit the connecting group. Use the alternative fixing holes where necessary.

Drill through the wall with a 100 mm core drill.

Refer to the air/flue duct installation instructions, Section 2, General, for full details.

- Remove the template from the wall and fit the mounting bracket in position (2) and the connecting group in position (3) using the wall plugs and screws provided ensuring both brackets are level and securely fixed to the wall.

If the condition of the wall is poor, additional or alternative screw fixings will be required to ensure adequate support.

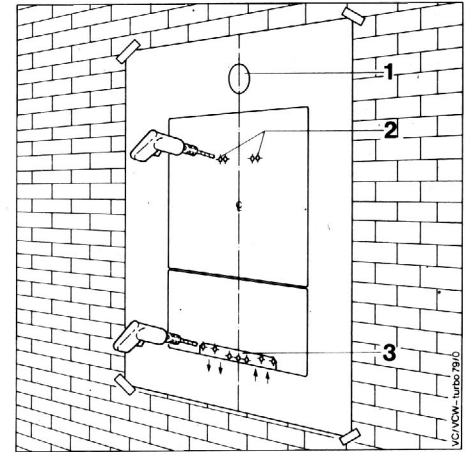

Fig. 12

9.1 Domestic cold and hot water connection

Note:

When the appliance is fitted, some adjustment of the position of the domestic hot and cold water connection fittings on the connection set may be necessary in the horizontal plane (e.g. movement up to 3 mm (0.12 in.) out from the wall). If the intended pipework cannot accommodate this movement, do not make the final domestic hot and cold water pipe connections to the connection set until after the appliance has been fitted.

- Flush out all foreign matter from the supply pipe before connecting to the connection set.
- Fit the 15 mm domestic mains water inlet pipe to the right hand compression union

(2) and the 15 mm hot water outlet pipe to the left hand compression union (3).

- Check domestic water system for soundness.

N.B.

The boiler has a maximum domestic water working pressure of 10 bar. A pressure relief valve is fitted to the D.H.W. system which is set at 10 bar. If water pressure exceeds this value a pressure reducing valve will have to be fitted to the cold water inlet.

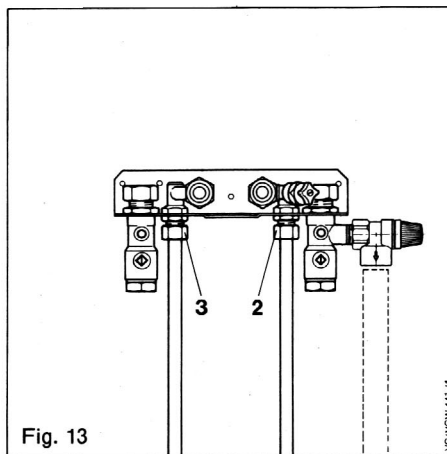

9.2 Connection of heating system

Flush out all foreign matter from the flow and return pipe before connecting to the connection set.

Heating system flow and return should be connected to the connection set as shown in Fig. 14 via 3/4" B.S.P. adaptors.

Fill the heating system and test for soundness.

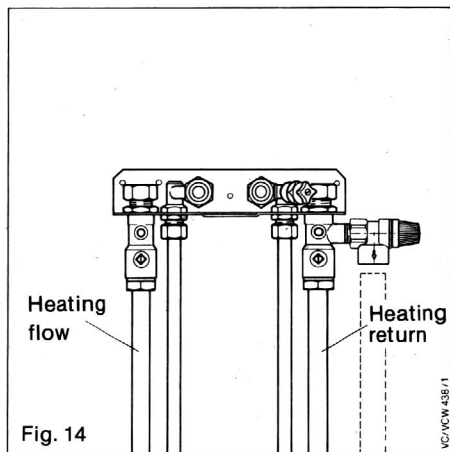

9.3 Pressure relief valve and overflow

The pressure relief valve (4), required for a sealed system, is included in the connection set 9313.

15 or 22 mm pipe should be connected to the pressure relief valve via a 3/4" B.S.P. adaptor.

This discharge pipework should be as short as possible and installed with a continuous fall away from the boiler. The pipe should terminate in a position which ensures that any discharge of water or steam from the valve cannot create a hazard to persons in or about the Premises, or damage to any electrical components or external wiring, and the point of discharge should be clearly visible. The discharge must not terminate above a window, an entrance or any type of public access. The installer must consider that the pipe could discharge boiling water.

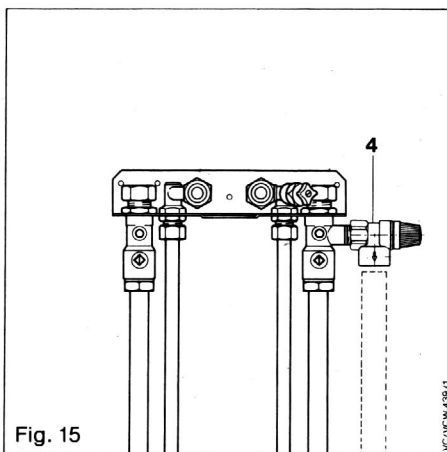

9.4 Air/flue duct

Before proceeding, refer to section 2 of the air/flue duct installation instructions and install the air/flue duct assembly.

9.5 Fitting the appliance

Close service cocks (5), unscrew union nuts (6) and take off the olive-shaped plastic plugs.

Close mains water service cock (8) and unscrew the union nuts (9), discard plastic plug.

Take care not to lose sealing washers.

Unpack boiler from carton and remove side panels (as in fig. 38) and packing aids as well as plastic caps from the connections.

Push union nuts (6) and compression rings (7) onto the C.H. flow and return pipes of the appliance. Temporarily secure nuts and rings well clear of the ends of the pipes with tape. Mount the appliance by inserting the connection tubes into the C.H. service cocks on the connection group and hang the appli-

ance with the crossbar (2) onto the appliance fixing bracket (3).

Loosen the back nuts securing the domestic hot and cold water connection fittings on the connection group bracket to permit movement.

Align domestic hot and cold water connections to the appliance, fit sealing washers and tighten union nuts (9). Retighten back nuts. Complete the final 15 mm pipe connections to the connection group if not already carried out in section 9.1.

Remove tape and tighten union nuts (6).

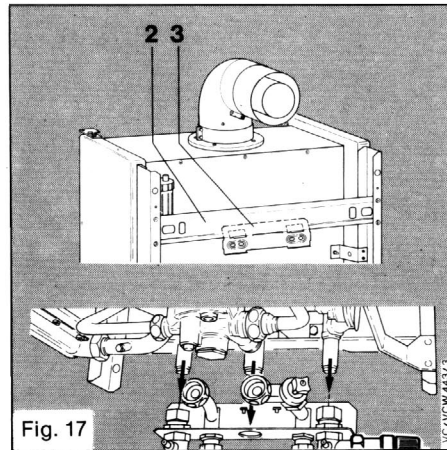
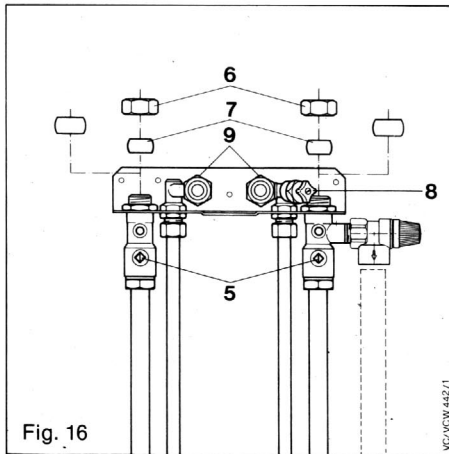

9.6 Gas connection

Fit the gas service cock (5) to the appliance.

Ensure the gas service cock is fully located on the appliance and the ON/OFF control is accessible.

Clean out all foreign matter from the gas supply pipe before connecting to the service cock!

Connect the gas supply pipe to the service cock and tighten.

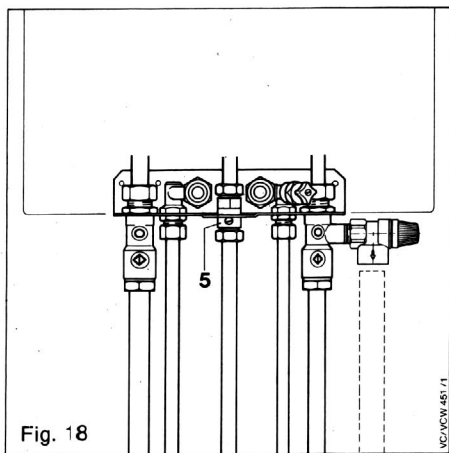

9.7 Connection of the air/flue duct to the appliance

Note:

Refer to the air/flue duct installation instructions for full details of installation of the air/flue duct.

This section is included for further reference only, in case the appliance has to be removed.

- Remove two screws (12) and take off half-ring (13).

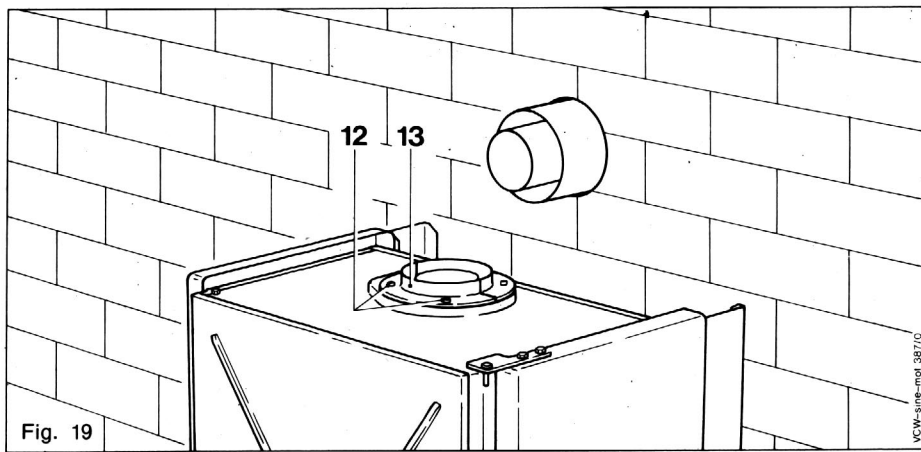

- Place a clamp (63 mm dia.) (14) loosely over the flue duct (1) and a further clamp (14) over the flue gas connection on the appliance.
- Loosen screws on clamp ring (dia 95 mm x 55 mm wide) 17 fig. 22 and push over air duct (2).
- Remove screws and sealing washer on clamp ring 16, Fig. 22 (dia. 95 mm x 25 mm wide) and push over the duct elbow on the side which is to be connected to the appliance. Ensure the clamp ring is clear of the end of the elbow.
- Push twin duct elbow (15) into the clamp (14) on the flue connection of the appliance.
- Pull clamp (14) over the butt joint between the flue duct (1) and the flue gas elbow and tighten lightly.
- Ensure that the flue gas elbow (15) is closely butted to the appliance. Ensure that the flue duct (1) is closely butted to the flue gas elbow (15) and has not been displaced outwards through the wall.
- Tighten screws on both flue duct clamp rings (14) in order to firmly secure the elbow and flue duct to the appliance.

Note: Excessive tightening of these screws is unnecessary.

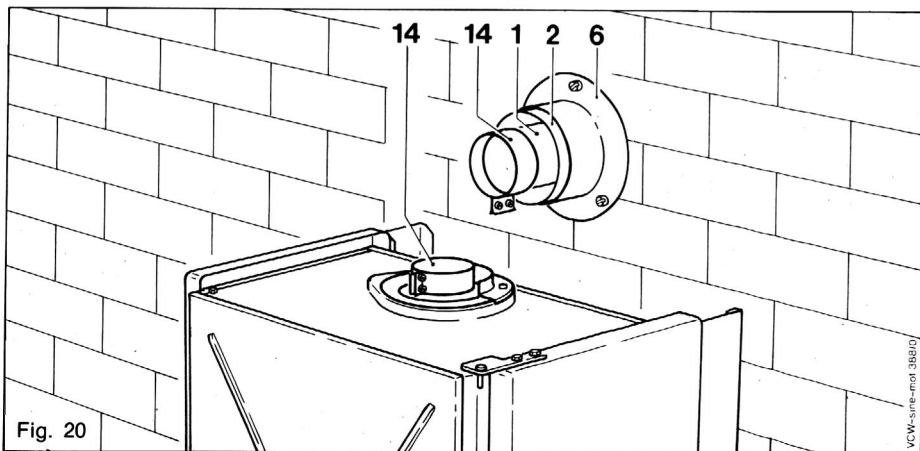

Fig. 20

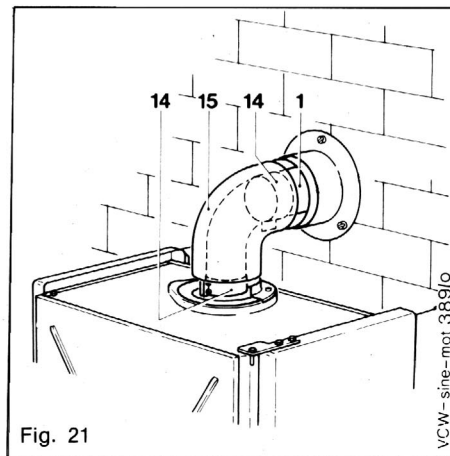

Fig. 21

- Refit the half-ring (13), align with the half-ring which remained and lightly screw on with the screws (12).
- Pull the clamp ring (dia. 95mm x 25 mm wide) (16) over the joint between the twin duct elbow (15) and the half rings (13). Refit screws and sealing gasket between the clamp flanges and tighten lightly.
- Pull the clamping (dia. 95 mm x 55 mm wide) (17) over the joint between the twin duct elbow (15) and the air duct (2) or the air duct of the extension (where used). Refit screws and sealing gasket between the clamp flanges and tighten lightly.
- Tighten screws on both air duct clamp-rings (16 and 17) in order to firmly secure the elbow and air duct to the appliance.

Note:

Excessive tightening of these screws is unnecessary. Ensure one of the holes (28) in clamp (17) is aligned with the hole in the top of the twin duct elbow and screw in self tapping screw 4.2 mm dia x 13 mm long. Firmly tighten screws (12).

- Drill a 3 mm dia hole through the air duct at the most convenient hole (28) on the clamp (17). Ensure the drill does not penetrate the inner flue duct and clean away any swarf. Screw the clamp (17) to the air duct with self tapping screw 4.2 mm dia x 13 mm long.

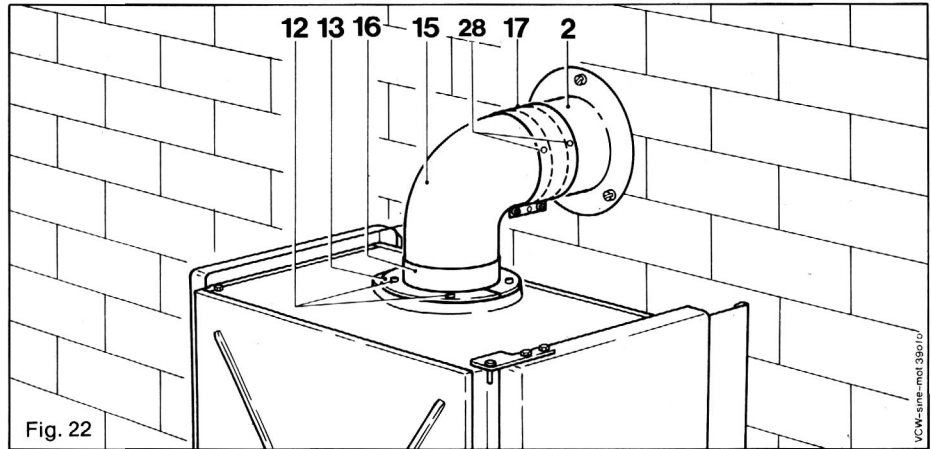

10 Electrical installation

Vaillant boilers are completely wired. It is only necessary to connect to the electrical mains and the room thermostat. Connect to a 230-240 V (~), 50 Hz electrical supply fused 3 A.

Warning! This appliance must be earthed.

The method of connection to the electricity supply must facilitate complete isolation and should preferably be via a fused, three-pin plug and unswitched, shuttered socket, both complying with the requirements of BS 1363. Alternatively, connection may be made via a fused, double-pole isolator having a contact separation of at least 3 mm in all poles and supplying the boiler and system controls only.

When connecting the power-supply cord, ensure that the length of the wires is such that the current-carrying conductors become taut before the earthing conductor should the cord slip from the cable clamp.

After removing the terminal box cover (1) connect the mains with the wire coloured blue to the terminal 1 (N) and the wire coloured brown to the terminal 2 (L) and the earth-wire coloured green and yellow to the terminal marked ⊕.

A 3 core flexible cord according BS 6500 tables 6, 8 or 16 (3x0,75 to 3x1,5 mm²) should be used. A cardboard label showing the correct mains connection to the terminals is in the terminal box.

Do not connect the electrical main supply to the terminals 7, 8, 9!

Use the first left-hand cable clamp for the power supply cord.

Full wiring diagrams for various control schemes are shown in fig. 24-27. Take care that the cords to the terminal box can not touch the hot water pipework, otherwise cords having a minimum appropriate T-rating of 90 shall be used. In the event of an electrical fault after installation, preliminary system checks i.e. earth continuity, polarity, resistance to earth shall be carried out.

List of terminals

| Terminals | Connection |
|-----------------------|--|
| 1, 2 | Mains |
| 3, 4 | Room thermostat (230-240 V~) |
| 5 | Neutral for ext. controls (230-240 V~) |
| 7, 8, 9 (20V only) | } N/A MUST NOT BE USED |
| 10, 11, 12 | |

- 1 Terminal box cover
- 2 Screw
- 3 Terminal strip
- 4 Earth connection
- 5 Cable grip
- 6 Cable grommet
- 7 Switch box
- 8 Screws
- 9 Screws
- 10 Lock-out reset button
- 11 Lock-out red neon
- 12 Fuses F 2 A
- 13 Pilot lamp "Operator on"
- 14 Pilot lamp "Diaphragm pump on"
- 15 Fuse (160 mA)

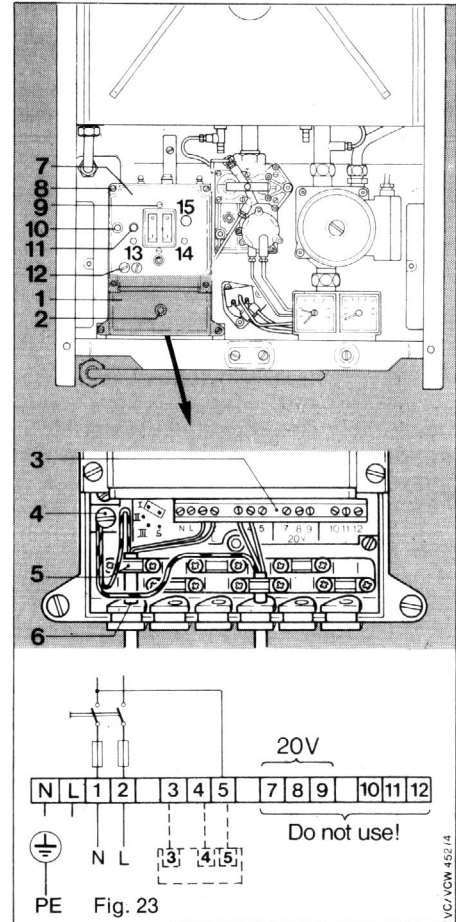

10.1 Connection of Vaillant room thermostat (VRT 378)

Connection of room thermostat is made to the terminals 3 and 4. It is recommended to install a Vaillant room thermostat (VRT) with accelerating resistance (terminal 5). The room thermostat must be installed on an inner wall which is influenced neither by current of air nor by sun, in the living room. During the installation of the room thermostat the manufacturer's instructions must be followed. For the sake of economy and comfort the Vaillant boiler should be regulated by a room thermostat with accelerating resistance. If the room thermostat is not connected, to operate the heating system for testing purposes after the installation, the unit can be operated by provisional application of a bridge between the terminals 3 and 4. When the room thermostat is wired in this bridge must be removed.

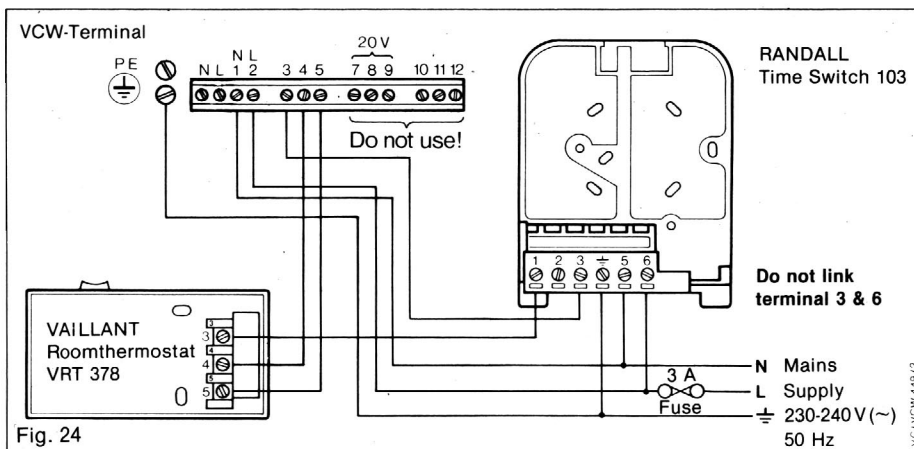

10.2 Thermostatic radiator valves

Where TRV's and a clock are used the switching side of the clock is connected between terminals 3 and 4.

Where no clock is used a wire bridge must be inserted between terminals 3 and 4.

Set pump control to position II.

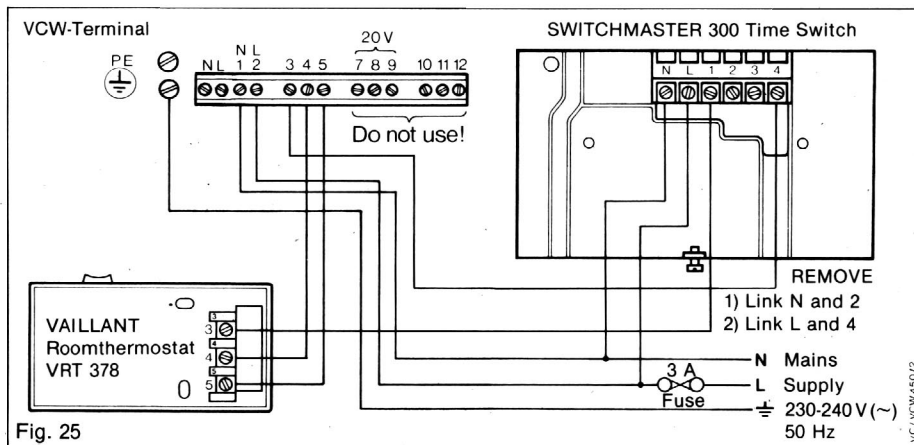

Frost Protection

If a frost thermostat is fitted then it should be connected in parallel across terminals 3 & 4 on the boiler.

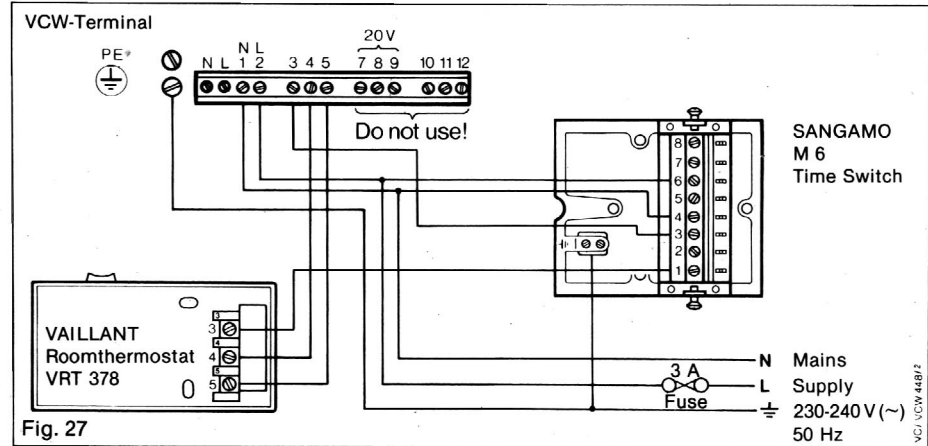
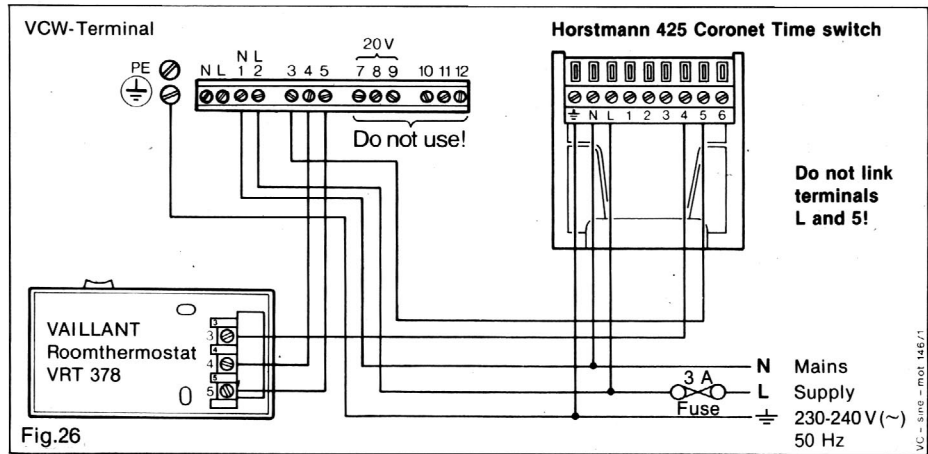

10.3 Operating modes of the system water circulating pump

In the factory, the heating system pump is set to operating mode (I) (electrical connection to contact I — see fig. 28).

By resetting the plug (1) to contacts I, II, III or S the following operating modes of the circulating pump become possible.

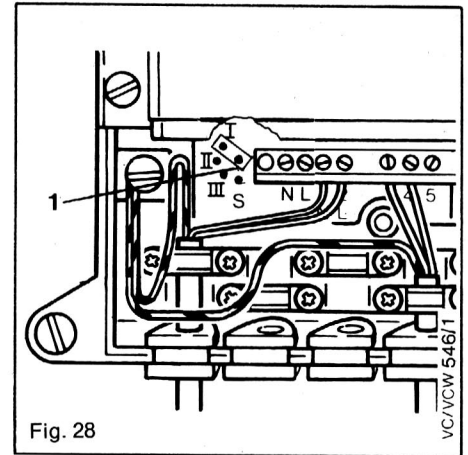

Connection to:

| | |
|--|---|
| <p>Contact I: (as supplied)</p> | <p>The pump is controlled by the room thermostat (only when connection is made across terminals 3 and 4).</p> |
| <p>Contact II:</p> | <p>The pump is controlled by the flow thermostat (electronic) only. After switching off the burner by the control, a pump over-run device will leave the pump running for about 20 seconds.</p> |
| <p>Contact III:</p> | <p>The pump runs continuously as long as the heating switch is on.</p> |
| <p>Contact S: (if fitted. This control is identified by the marking HY on the control box front cover)</p> | <p>The same as contact II but, after switching off the burner by the control, a pump over-run device will leave the pump running for about 5min (factory setting).</p> |

10.3.1 Reignition delay for the heating system

The appliance control incorporates a reignition delay to prevent rapid on-off cycling of the burner in the C.H. mode. This delay is factory set to 5 minutes.

On appliances which use a control box marked HY on the front cover, it is possible to change the re-ignition delay if necessary.

Remove the screw (2) to adjust the potentiometer, which is behind the screw.

Adjustment range: about 1-12 minutes.

If the time has been changed the over-run of the pump (connection S) will be also changed accordingly.

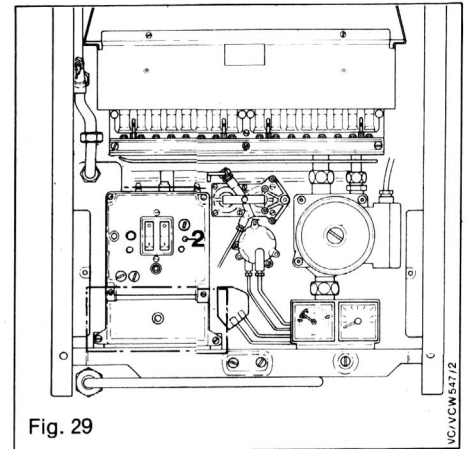

Fig. 29

CALOTROL - VRT 394

The Vaillant Room thermostat CALOTROL - VRT 394 includes a timer with five degrees set-back operation. The CALOTROL can operate in one of two modes.

- A) Automatic temperature set back (fig. 30) or
- B) ON/OFF operation with room temperature control (fig. 31)

CALOTROL - VRT 394 Timed Automatic Set-back operation

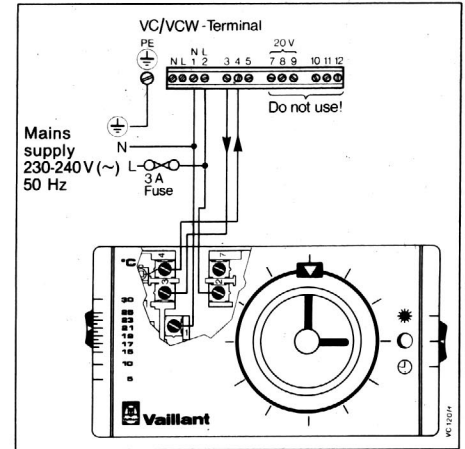

Fig. 30

CALOTROL - VRT 394 ON/OFF operation and room temperature control

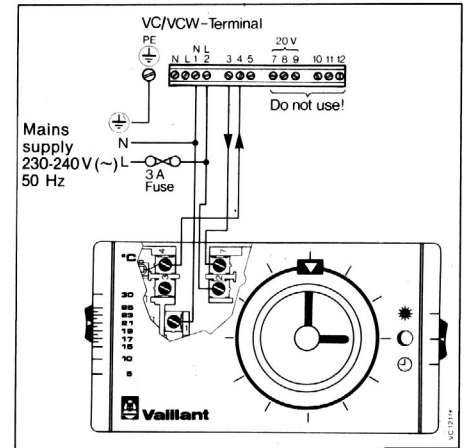

Fig. 31

Schematic appliance circuit diagram

(This version is for appliances with HY marked on front cover of control box)

VCW GB 242 EH / VCW GB 282 EH (with Hybrid)

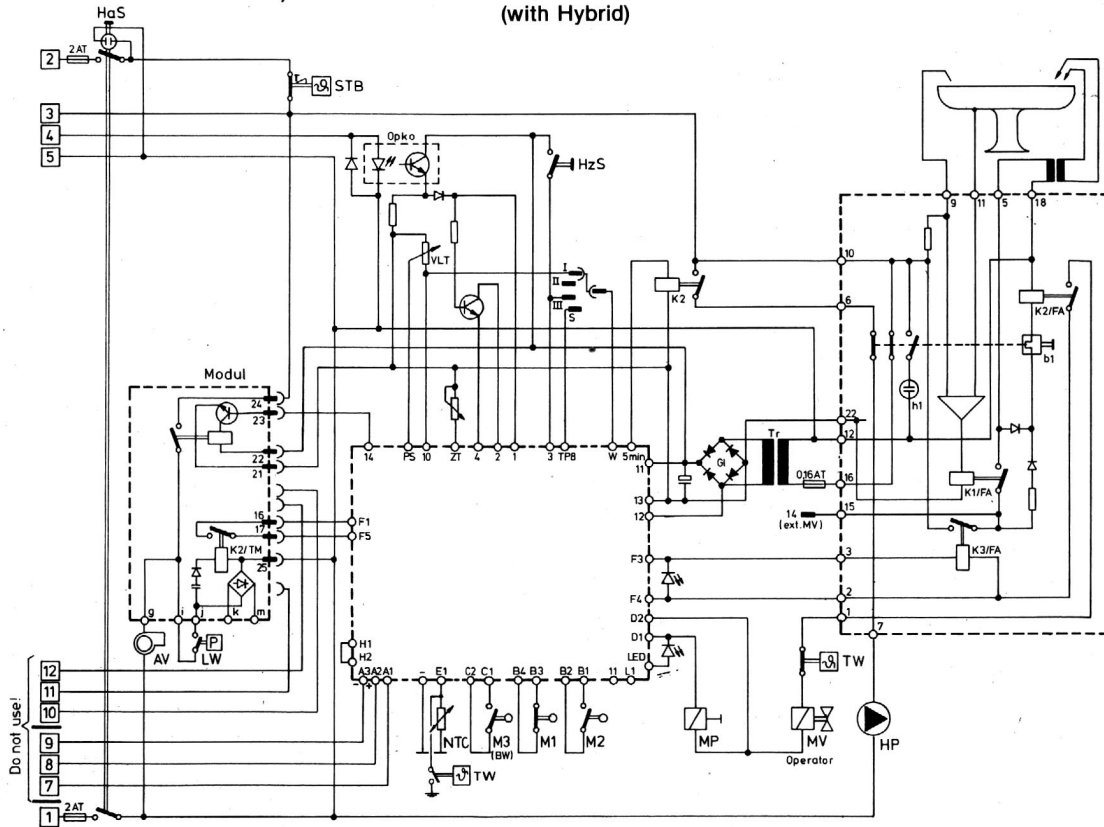

Fig. 33

VCW/VCW turbo 112/0

11 Commissioning and testing

11.1 Electrical installation

Check the electrical installation by carrying out short circuit, earth continuity and resistance to earth tests and check for correct polarity.

11.2 Gas installation

The whole of the gas installation, including the meter, should be inspected and tested for soundness and purged in accordance with the recommendations of BS 6891.

11.3 Central heating system

The whole of the system must be flushed out with both cold and hot water. Ensure all valves at the system and the appliance service cocks are open.

Open the stop cock gradually at the filling point connection to the central heating system until water is heard to flow. Do not open fully.

The system should be filled and air locks cleared. Starting with the lowest radiator open each air release valve closing it only, when clear water, free of bubbles, flows out. In the same way release air from any high points in the pipework.

For venting the boiler, back off the screw on the heat exchanger (1, Fig. 34) (see 13.4 to gain access) and the circulating pump (2) by about 1-2 turns.

Fill the sealed system until the pressure gauge registers 1.5 bar (21.5 PSI).

After initial brief operation, once again drain the complete installation through the lowest point of the system to remove residues from the pipework.

In continuous operation, the appliance is vented automatically through the automatic air vent (3). It is for this reason **essential** that the cap (4) present on the top of the automatic air vent is **unscrewed** by about 1-2 turns and that it **remains** like that.

Check operation of pressure relief valve by lifting the lever or rotating the knob anticlockwise, where applicable. Release water from the system until the initial system pressure of 1.2 bar is attained.

11.4 Filling the domestic hot water circuit

Fill the domestic hot water circuit of the appliance.

- Open the cold water stop valve (2) on the appliance.
- Open the connected hot water tap (1) and draw water

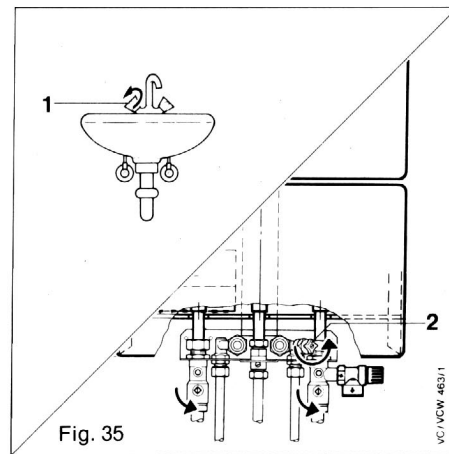
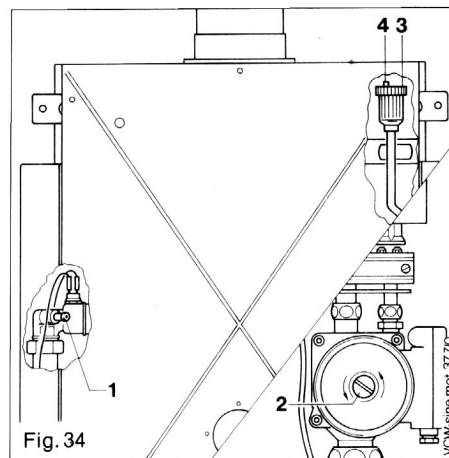

11.5 Lighting the boiler

The first lighting of the appliance shall be done by a qualified fitter only. He shall also give clear verbal instructions to the user on how to operate the boiler, controls and systems generally as described separately in the "Instructions for use".

Turn on gas service cock. Ensure electrical supply is on. Ensure external controls are calling for heat.

Light the boiler by pushing main switch and heating switch into position 1 (ON).

11.6 Gas soundness

In order to test the gas soundness of the burner gas connections it is necessary to temporarily operate the appliance with the inner case front panel removed. To do this, connect a suitable length of plastic tube to the test point (TP, fig. 36). Do not remove existing adjacent plastic pipe. Do not touch fan motor assembly or wiring. Turn on main switch and heating switch and suck using mouth pressure on the plastic tube. This suction will operate the air pressure switch and the main burner will light. Squeeze tube to maintain suction whilst carrying out gas soundness test on burner and burner test point connections. Shut down appliance and remove tube. Refit inner case front panel (13.4) and check gas soundness of remaining integral gas components and joints with the main burner alight.

Warning: Do not operate the appliance with the inner case front panel removed for more than a few seconds. Ensure adequate room ventilation. Shut down and refit inner case front panel immediately after completing gas soundness checks. Ensure that the front case inner panel is correctly located over the top lip of the inner case and is fitted correctly to provide a good seal.

11.7 Test of flame supervision device (F.S.D.)

With the appliance running with the main burner alight, turn off the gas supply at the appliance service cock. The burner will extinguish and the ignition system will start sparking. After approximately 10 seconds, the appliance should shut down, the lock out black button on the control box should pop out and the red lock out neon should light.

Turn on gas service cock and push black button to reset.

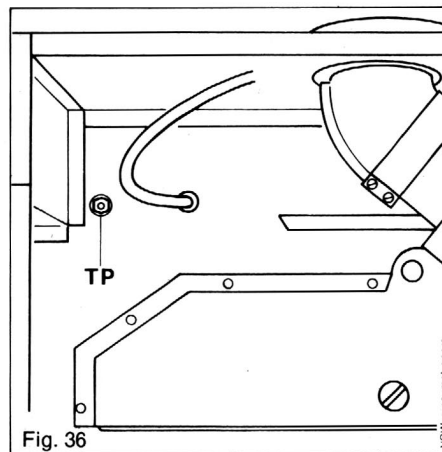

Fig. 36

VCW-une-not 388/0

11.8 Gas pressure

11.8.1 Main burner pressure

Draw D.H.W at a high rate.

Check the main burner gas pressure by connecting a pressure gauge to the test point (fig. 37). The main burner pressure is factory set and sealed to 5.1 ± 0.5 mbar (VCW GB 242 EH) and 6.8 ± 0.6 mbar (VCW GB 282 EH). Therefore, it is not necessary to alter the setting during commissioning. If the pressure is incorrect initially check that a 20 mbar inlet gas pressure is available at the inlet to the appliance. If the inlet gas pressure is less than 20 mbar, remedy external fault or contact Local Gas Supplier. If inlet gas pressure is 20 mbar, contact Vaillant Ltd.

Note: The main burner pressure immediately after ignition (ignition rate) will be only 1.5 ± 0.5 mbar (VCW GB 242 EH) and 1.0 ± 0.5 mbar (VCW GB 282 EH). After a few seconds of appliance operation, the main burner pressure will automatically increase to the maximum rate as outlined above.

11.9 Flow thermostat

Allow the C.H. System to warm up and adjust the position of the flow thermostat to check that the burner modulates down from high to low and low to off and vice versa (scale range covers about 35 to 90°C).

Note: The appliance control incorporates a re-ignition delay to prevent rapid on-off cycling of the burner in the C.H. mode. This delay can be bypassed by briefly switching the main switch off and on again, so that the appliance-provided heat input is required-starts immediately after the main switch has been operated.

11.10 Water soundness and final system flush

Allow the water system to reach maximum working temperature and examine for water soundness. The boiler should then be turned off and the C.H. system rapidly drained while still hot. The C.H. system should again be filled and cleared of air locks (see 11.3). Sealed systems should be adjusted to the initial system design pressure of 1.2 bar. The actual reading of the pressure gauge should ideally be 0.5 bar plus an additional pressure corresponding to the head of the highest point of the system above the base of the appliance, (10 m head equals an additional 1 bar reading on the pressure gauge), in any circumstances the minimum gauge reading should not be less than 1.0 bar. Finally set the red hand of the pressure gauge to 0.8 bar. Examine for water soundness.

Note:

If the system is to be treated with an inhibitor it should be applied at this stage. Sentinel X100 is suitable for this purpose and should be applied in accordance with the manufacturers instructions.

Further information can be obtained from Sentinel, Grace Dearborn Ltd.
Tel.: 0151 495 1861.

11.11 Air/flue duct assembly

Check visually the installation and function of the air/flue duct assembly.

11.12 Assemble appliance case (see chapter 12)

11.13 User's instructions

Hand the instructions for use to the user for retention and instruct in the safe operation of the appliance. Advise the user of the precautions necessary to prevent damage to the system and to the building if the system does not remain operative during frost conditions.

Finally, advise the user that for continued efficient and safe operation, this Vaillant appliance should be serviced at least once a year by a qualified servicing company. It is important and strongly recommended that arrangements are made for a MAINTENANCE AGREEMENT with a qualified servicing company to ensure regular servicing.

Please contact

Vaillant Service Department
(freephone 0800 318076)

for further details.

Note:

Leave installation and servicing instructions with the user when the installation is completed..

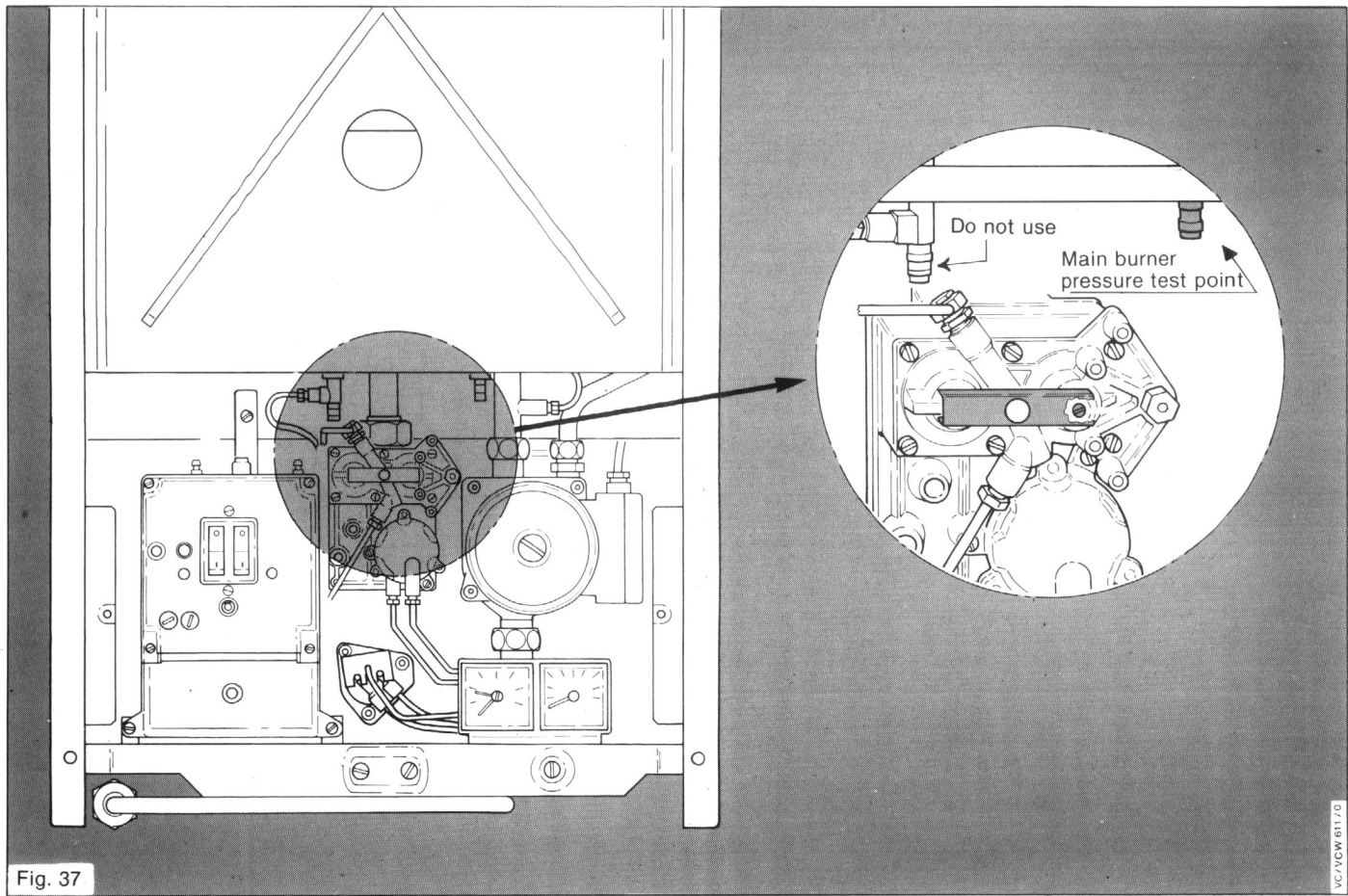

Fig. 37

VC/VGW 611/0

12 Assembling

12.1 Door hinges

The Vaillant boiler is pre-assembled in the factory for "doors hinged at the right" (see Fig. 39).

If the doors are required to be "hinged at the left", make the following changes (see Fig. 39).

- a) Unscrew door hinges top (1 a), centre (1 b) and bottom (1 c) from the right-hand side panel (2) and screw them the other way round to the left-hand side panel (3).
- b) Remove name plate from the upper appliance door, rotate it through 180° and refit. Engage upper door in the hinges mounted on the left hand side panel. Secure the door by screwing hinge bolt into appliance door guide (1a, fig. 39).
- c) For the installation of the lower appliance door see next page. (12.5, Fig. 39).

12.2 Side panels (Fig. 38)

Place the two side panels (2, 3) from the front into the upper and the lower pin (6) of the appliance frame and screw tight with the screws (7) at the upper (8a) and the lower support strip (8b).

12.3 Screen plate

Screw on the screen plate (9) with the screws (10). Do not overtighten.

- 2 Side panel (right-hand)
- 3 Side panel (left-hand)
- 6 Pin
- 7 Screw
- 8a Support strip (top)
- 8b Support strip (bottom)
- 9 Screen plate
- 10 Screw

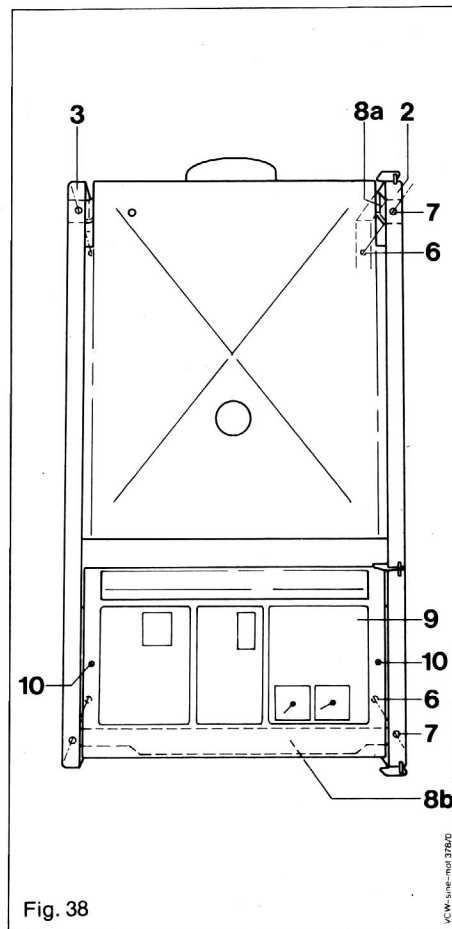

12.4 Upper appliance door

- a) Engage upper appliance door (5) in the door hinge (1b).
- b) Screw the hinge bolt of the upper door hinge (1a) into the appliance door guide.

12.5 Lower appliance door

- a) Engage lower appliance door (12) in the door hinge (1b).
- b) Screw the hinge bolt of the lower door hinge (1c) into the appliance door guide.

12.6 User operating instructions label

IMPORTANT

Position and fix self adhesive

- user instructions
- wiring diagram

to the inner side of the door as shown on Fig. 39.

Ensure all surfaces are cleaned before affixing labels.

- 1 a,b,c Door hinges
- 2 Side panel (right-hand)
- 3 Side panel (left-hand)
- 4 Magnet
- 5 Appliance door (top)
- 12 Appliance door (bottom)
- 13 Magnet holder

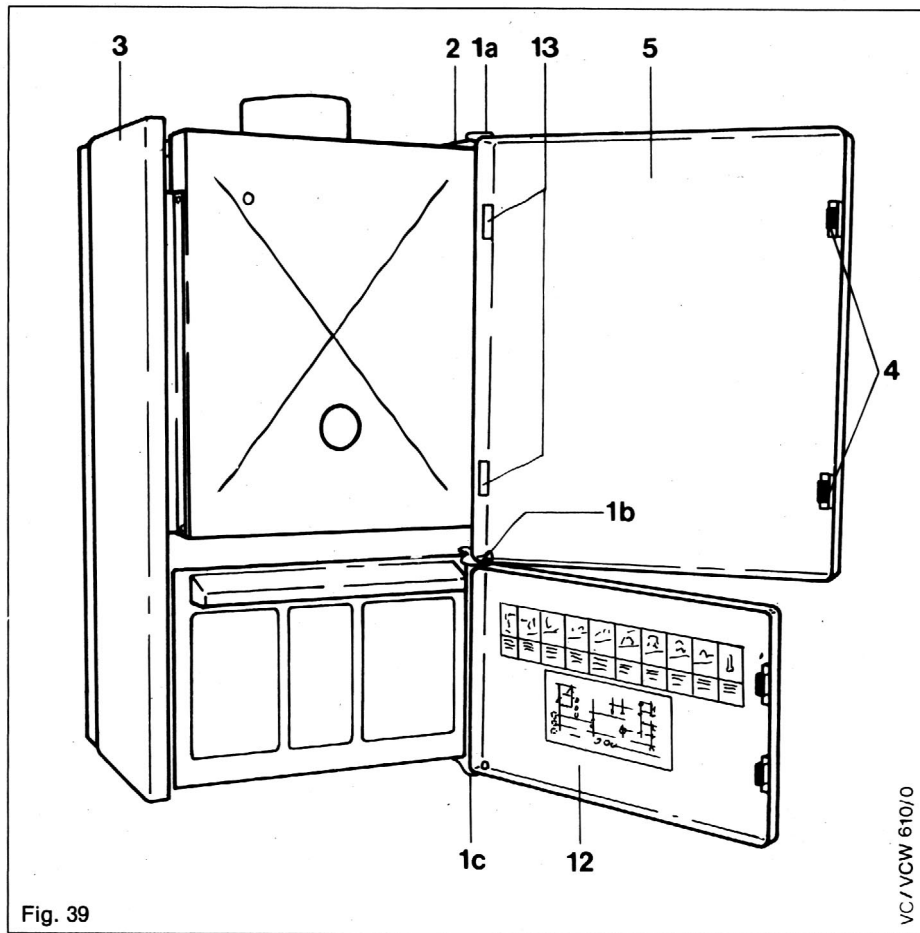

13 Servicing of boiler

To ensure the continued safe and efficient operation of the boiler it is recommended that it is checked and serviced as necessary at regular intervals. The frequency of servicing will depend upon the particular installation conditions and usage, but in general once per year should be adequate. It is law that all servicing work is carried out by a competent person (Corgi registered). The data plate is located on the underside of the inner case (8, fig. 11).

IMPORTANT

Warning:

Before starting any maintenance work, switch OFF the mains electricity supply and disconnect the plug at the main isolating switch and socket. (If a switch is used, remove the fuse).

Turn OFF gas supply at the gas service cock fitted to the appliance. Always test for gas soundness after any service work and after exchanging any gas carrying component and always carry out functional checks.

Always after any service work and after exchanging any electrical component.

Check — earth continuity
— polarity
— resistance to earth.

To service the boiler follow the sequence 13.1 to 13.8

13.1 Inspection

13.1.1 Inspect exterior of the boiler, in particular the pipework, electrical connections and flue assembly for indications of damage or deterioration.

13.1.2 Inspect the air supply and ventilation arrangements of the installation ensuring that the requirements of 5.5 and 5.6 are met.

13.1.3 Operate the appliance by drawing off DHW at a high rate and inspect the burner operation through the viewing window. Check that the flames are of light blue colour and over all burner ports. Inspect for signs of yellowing, excessive lifting or sooting.

13.2 Turning off the boiler

- Isolate the electrical supply to the boiler
- Turn off gas service cock (3, fig. 40)
- Turn off boiler C.H. service cocks (4, fig. 40)
- Turn off DHW cold water service cock (5, fig. 40)

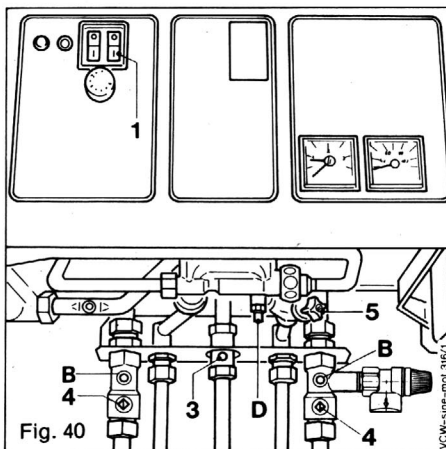

Fig. 40

13.3 Removing outer case (Fig. 39)

Remove upper door by unscrewing hinge pin (1a) and pulling door out and up. Remove lower door by unscrewing hinge pin (1c) and pulling door out and down.

Remove screen plate by unscrewing the two fixing screws (10, Fig. 38).

Remove side panels by unscrewing top and bottom screws (7, Fig. 38) to clear internal clips and then pulling panels outwards and off.

13.4 Removing inner case

Remove screw (A, fig. 41)

Release the two clips (B) securing the bottom edge of the inner front panel by pressing spring clips upwards. Lift bottom edge of front panel outwards and unhook from the top of the inner case. Inspect the case seal - if damaged, obtain a replacement case panel.

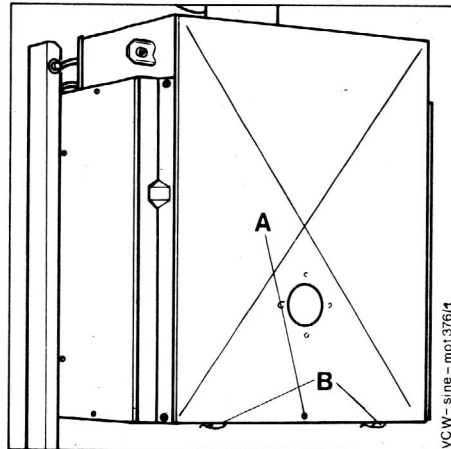

Fig. 41

13.5 Cleaning of burner (Fig. 42)

Remove red high tension leads (HT) from spark electrodes and transparent cable (FS) from flame sensing electrode.

Remove the four screws (S) and lift burners up and out.

Disconnect both ends of burner test point extension (E) and remove. Remove burner bar fixing screws (BS).

Remove burner bar by easing forward (BB).

Clean burners and injector nozzles with a light brush or a vacuum cleaner.

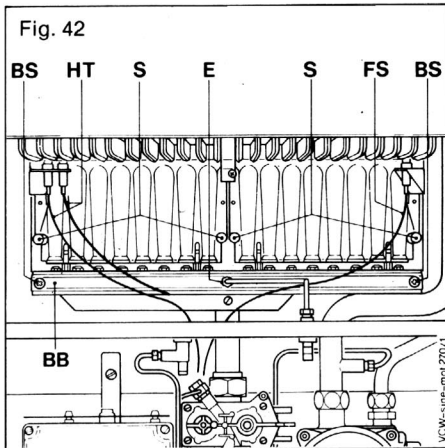

13.6 Cleaning of main heat exchanger (Fig. 43)

Place cloth below combustion chamber

- Remove fixing screws (2) and take off cover sheet (3)
- Inspect bottom of heat exchanger through the combustion chamber using a torch and clean if necessary with a stiff long bristle brush.
- Gain access to the top of the heat exchanger by removing the fan (see 14.9) and flue hood (2 screws). Inspect heat exchanger and clean if necessary using a stiff long bristle brush.
- Reassemble in reverse order.

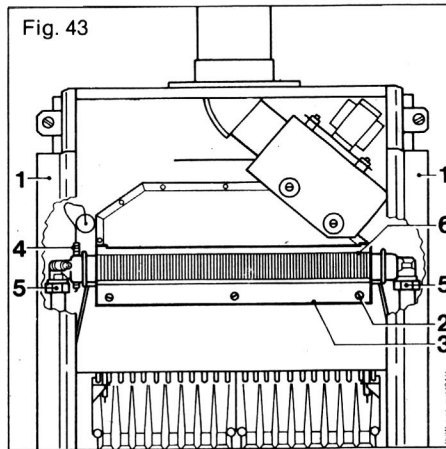

13.7 Check of C.H expansion vessel

Close C.H. service cocks (4, fig. 40)

Release pressure from the appliance as described under 14.23.

Remove protective cap.

Check internal pressure of expansion vessel which should be 0.7 to 0.9 bar (Fig. 44), access from underneath the appliance. Re-pressurise the expansion vessel as necessary using an air pump.

Open C.H. Service cocks and repressurise C.H. System if necessary.

(See appropriate paragraphs of 11.10)

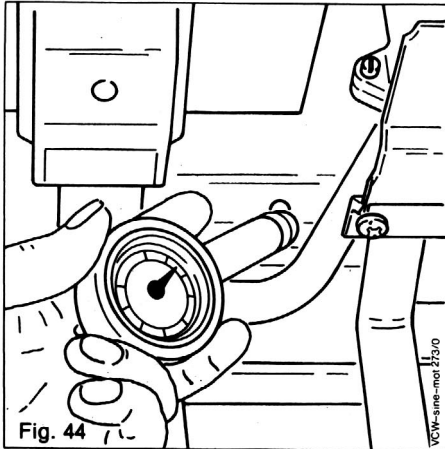

13.8 Recommissioning the appliance

- a) Refit inner case side panels
- b) Reconnect electrical supply
- c) Turn on gas service cock
- d) Operate burner with inner case front panel removed in order to test gas soundness of burner and burner test point connections (11.6)
- e) Refit inner case front panel (13.4). Ensure the panel is correctly fitted and a good seal is obtained.
- f) Light the boiler (11.5)
- g) Check gas soundness of remaining gas connections (11.6)
- h) Check gas pressure (11.8)
- i) Test flame supervision device (11.7)
- j) Test C.H. flow thermostat (11.9)
- k) Check water soundness (11.10)
- l) Check air/flue duct assembly (11.11)
- m) Carry out electrical test (11.1)
- n) Refit outer case (12)

14 Replacement of parts

General

Before starting any replacement of parts, switch OFF the main electricity supply and disconnect the plug at the main isolating switch and socket. (If a switch is used, remove the fuse).

Turn off gas supply at the gas service cock. Always test for gas soundness after any service work and after exchanging any gas carrying component.

Always carry out functional checks.

After breaking any internal electrical circuit check — earth continuity

- polarity
- resistance to earth.

14.1 Change of electrodes (Fig. 45)

Remove outer case and inner case (13.3 and 13.4).

Pull off the two red high tension leads (HT) or the transparent sensor lead as appropriate.

Remove the appropriate burner retaining screws (S) lift and pull out burner (B). Remove fixing screw for the electrode assembly. Replace electrode assembly and reassemble in reverse order.

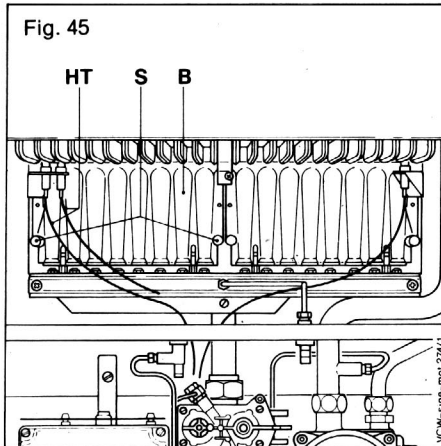

14.2 Change of NTC resistor (Fig. 46)

Remove outer and inner case as under 13.3 and 13.4.

Disconnect the push on connector and unscrew the NTC probe.

Reassemble in reverse order.

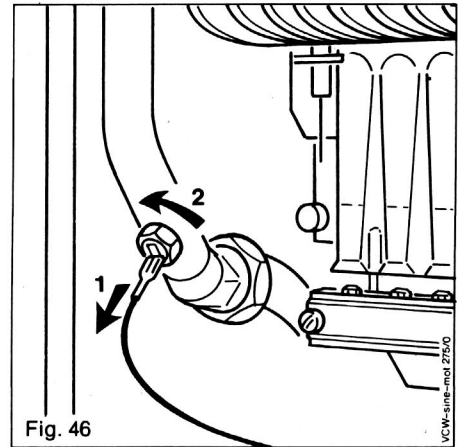

14.3 Change of automatic air vent (Fig. 47)

Remove outer case as under 13.3

Release system pressure as under 14.23.

Unscrew the automatic air vent by hand. Reassemble in reverse order, screwing in the automatic air vent by hand only.

Open the locking cap (LC) of the automatic air vent by 1—2 turns.

Reassemble casing in reverse order and repressurise system.

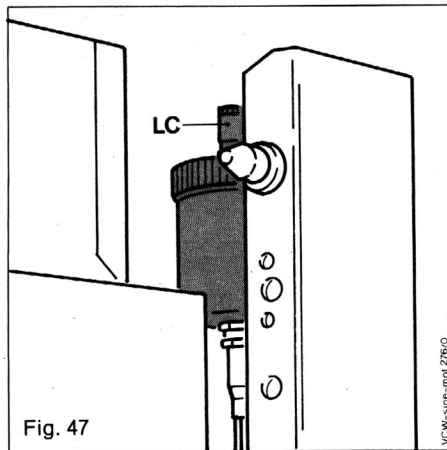

14.4 Change of diverter valve or parts

14.4.1 Electrical isolation (Fig. 48)

Remove outer case as under 13.3

Ensure the appliance is isolated from the electrical mains. Pull off the plug (S1) by shifting the retaining tongues' (S2) top and bottom to the side.

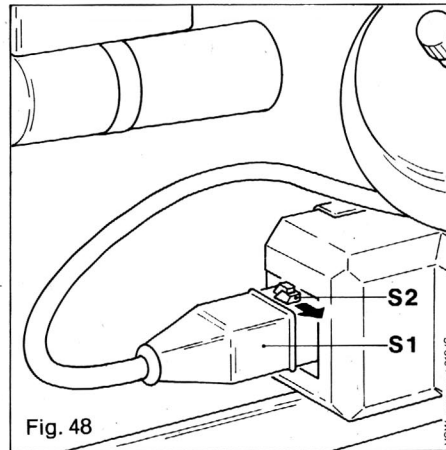

14.4.2 Change of diverter valve micro-switches (Fig. 49)

Spring off the protective cover (S6).

Unscrew two retaining screws (RS, fig. 51) securing complete microswitch assembly. Remove complete assembly.

Remove screws (S7) or (S8) as appropriate, take off microswitch and remove the two push on connectors.

Reassemble in reverse order, adjust the actuating lever as under 14.4.3.1.

Note:

The black cables are connected to microswitch S7. The brown and blue cables are connected to microswitch S8.

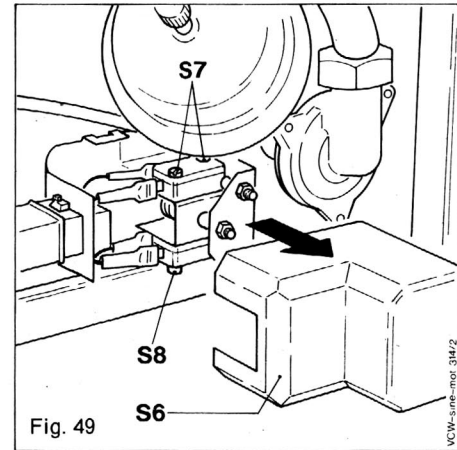

14.4.3 Removal of complete diverter valve (Fig. 50)

Carry out operation 14.4.1.

Drain the C.H. side of the appliance (14.24). Remove D.H.W. expansion vessel (14.12.1). Mark and disconnect the control lines (CL).

Note:

The bolt which secures the control line banjo connection contains a restrictor orifice. Check this orifice is clear.

Remove the three unions (U).

(If access to the L.H. union is restricted, leave this union undisturbed and disconnect pipe from D.H.W. heat exchanger. With draw diverter valve together with pipe carefully. Take care when reassembling not to over-tighten the union connection to the D.H.W. heat exchanger. Ensure threads are correctly engaged.)

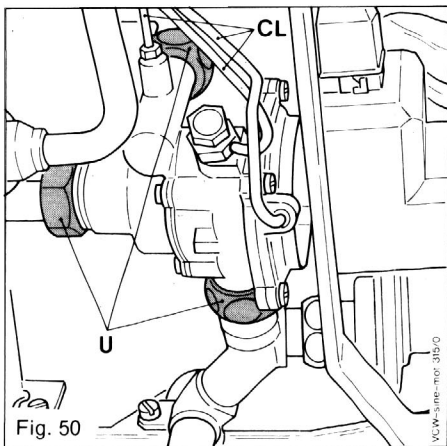

14.4.3.1 Change of diverter valve stuffing box (Fig. 51)

Carry out operation (14.4.1)

Carry out operation (14.4.3) to remove the complete diverter valve.

Spring off protective cover (C).

Unscrew two retaining screws (RS) and remove complete microswitch assembly.

Unscrew stuffing box and replace using a new washer. Reassemble in reverse order and adjust actuating lever as follows:

Turn down spindle (1) slowly until microswitch closes the blue to brown circuit and make $\frac{2}{3}$ more turn down. Press the lever assembly down to the rest and turn down spindle (2) slowly until microswitch closes the black to black circuit and make $\frac{1}{2}$ more turns down.

Lock spindles with locking nuts (3).

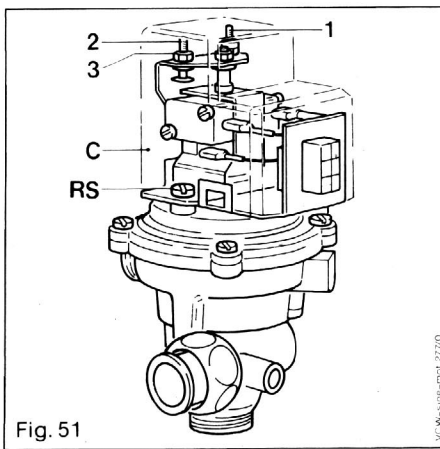

14.4.3.2 Change of diaphragm (Fig. 52)

Carry out operation 14.4.1.

Carry out operation 14.4.2 and 14.4.3 to remove complete diverter valve and micro-switch assembly.

Note position of the housing (H) and the diaphragm (D).

Remove the retaining screws (RS).

Check diaphragm disk (DD) for free movement. Reassemble in reverse order.

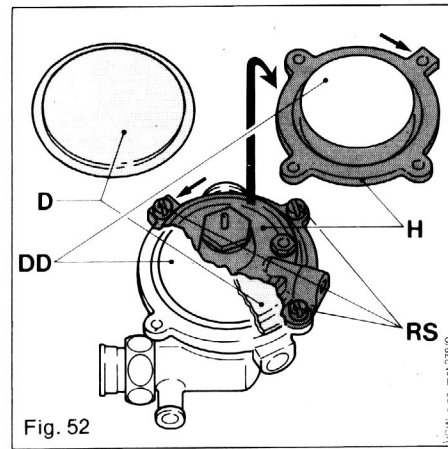

14.4.3.3 Change of internal parts (Fig. 53)

Carry out operation 14.4.1.

Carry out operation 14.4.3 to remove complete diverter valve.

Unscrew carefully the three retaining screws (RS), remove housing and change if necessary O-ring seal. Do not use any jointing compound or grease.

Check valve (V) and replace if necessary. Reassemble in reverse order.

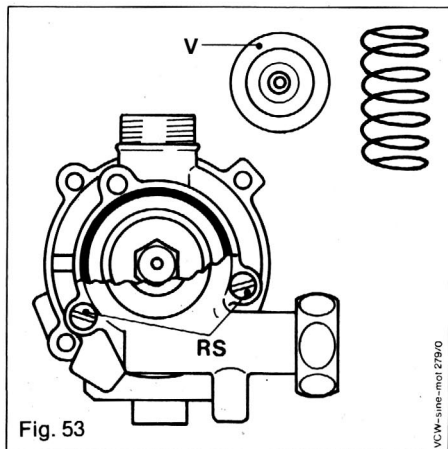

14.4.4 Reassembling

Reassemble in reverse order, using new washers.

Check — earth continuity
— polarity
— resistance to earth.

Note: position of notches on plug as shown.
(Fig. 54)

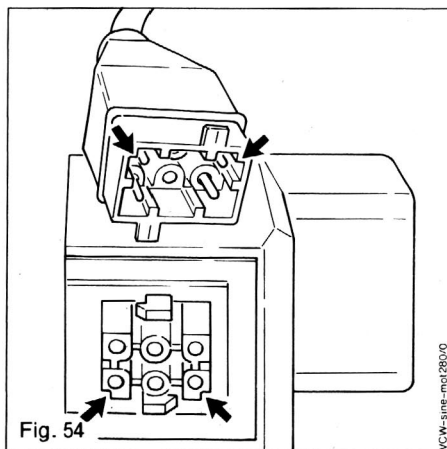

14.5 Gas section

Access to the gas section can be improved by removing the retaining screws (RS, fig. 62) and pulling the control box forward.

14.5.1 Change of operator (Fig. 55)

Turn off boiler as under 13.2.

Remove outer case as under 13.3.

Isolate the appliance from the electrical mains and pull off the cable connectors (P) from the operator (O).

Disconnect the control lines (CL) by unscrewing retaining bolt (RB) and union nut (UN). Unscrew the four retaining screws (RS).

Reassemble in reverse order using new gasket (G).

Check for gas soundness. Carry out electrical checks (11.1).

Check burner pressure.

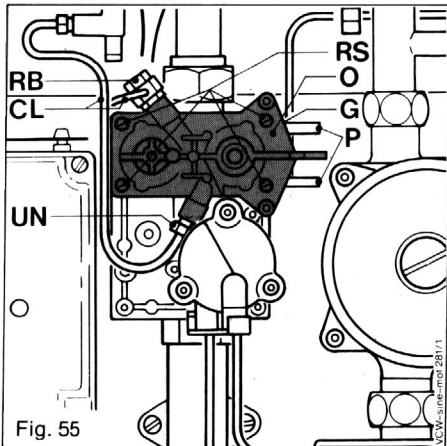

14.5.2 Change of gas section (Fig. 56)

Turn off boiler as under 13.2.

Remove outer case as under 13.3.

Release system pressure in C.H. side as under 14.23.

Isolate the appliance from the electrical mains and pull off the connectors (P) from the operator (O).

Disconnect the two control lines (CL) by unscrewing the retaining bolt (RB) and the union nut (UN).

Note the connection of the two control lines to the differential valve. Note the connections of the other ends of these control lines. Remove clamp (BR) by sliding sideways.

The control lines are a push fit into the differential valve. (Disconnect connections of the

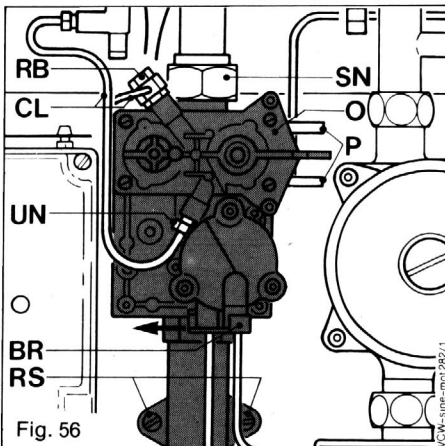

other ends of the control lines to gain movement as necessary. Ensure all connections are noted to assist reassembly).

Remove the two retaining screws (RS) and loosen the sleeve nut (SN).

Reassemble in reverse order using new washers. Check connections for gas soundness. Carry out electrical checks (11.1).

Check burner pressure (11.8).

14.5.3 Change of differential valve (Fig. 57)

Turn off boiler as under 13.2.

Remove outer case as under 13.3.

Release system pressure in C.H. side as under 14.23.

Note connections of the two control lines to the differential valve. Note the connections of the other ends of these control lines. Remove clamp (C) by sliding sideways. The control lines are a push fit into the differential valve. (Disconnect connections at the other ends of the control lines to gain movement as necessary. Ensure all connections are noted to assist reassembly). Unscrew the three retaining screws (RS). Dismantle differential valve and clean (fig. 58).

Check diaphragm and replace if necessary. Check stuffing box to ensure diaphragm disc is free to move and replace if necessary. Lubricate pin with suitable grease. Reassemble in reverse order.

Repressurise appliance.

14.5.4 Change of gas section stuffing box (Fig. 59)

Remove the differential valve as under 14.5.3.

Unscrew the stuffing box (SB) taking care not to bend the pin.

Reassemble in reverse order, using new washers.

Check connections for gas soundness.

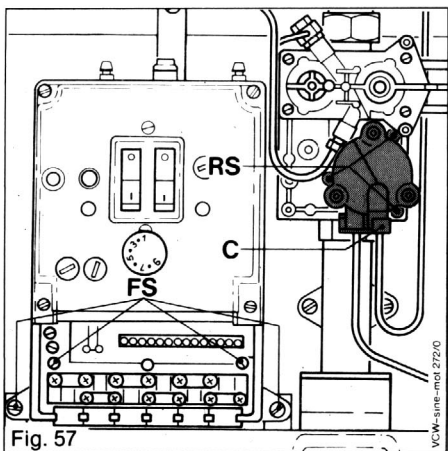

Fig. 57

VCW-sme-mod.272/0

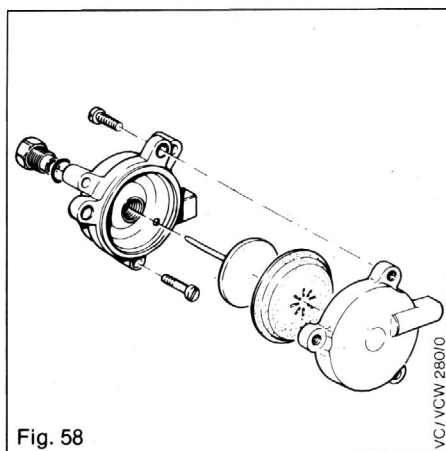

Fig. 58

VC/VCW 280/0

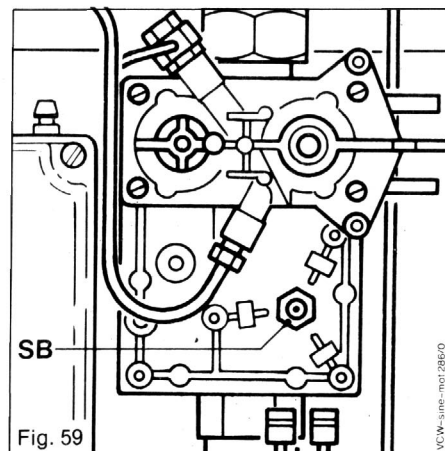

Fig. 59

VCW-sme-mod.286/0

14.6 Change of pump (Fig. 60)

Turn off the appliance 13.2.

Remove outer case as under 13.3.

Remove inner case as under 13.4.

Drain C.H. side of appliance (14.23 and 14.24).

Open terminal box of the pump.

Note the colour code of wiring and disconnect cable.

Unscrew the sleeve nut (SN) of the air vent pipe.

Unscrew the two unions (U) of the pump.

Reassemble in reverse order using new washers and repressurise system.

Carry out electrical checks (11.1).

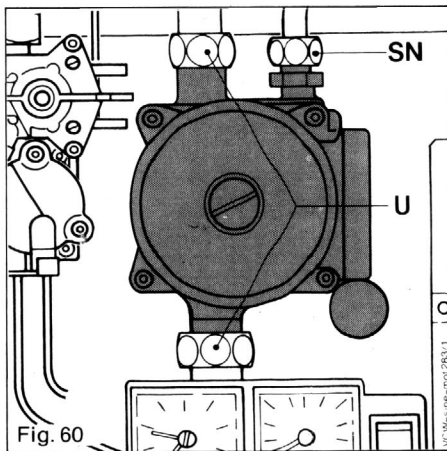

14.7 Control box

14.7.1 Opening control box (Fig. 62)

Remove outer case as under 13.3.

Isolate the appliance from the electrical mains. Open the terminal box by removing the retaining screw (TS). Mark the wiring and remove it from the terminal block. Remove the four retaining screws (BS). Pull out slowly the control box cover complete with the switch board and printed circuit boards.

Pull off the multiple plugs from the PC boards. Reassemble the control box in reverse order.

When replacing the screws, position the star washer under the left lower screw.

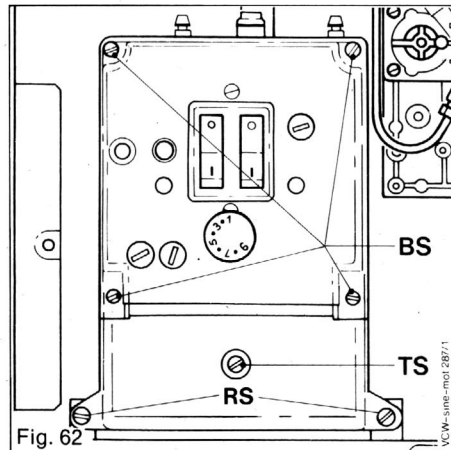

14.7.2 Change of fan control circuit board (F.C.C.B.) (Fig. 63)

Take off control box cover as under 14.7.1.

Unscrew the two retaining screws (RS) or push out the plastic retaining clips (where fitted) and remove FCCB from the main switch circuit board by lifting up.

Reassemble in reverse order.

Carry out electrical checks (11.1).

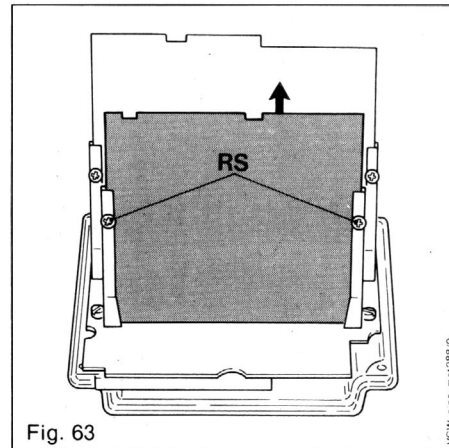

14.7.3 Change of electronic thermostat circuit board (T.C.B.) (Fig. 64)

Take off control box cover as under 14.7.1 and F.C.C.B. as under 14.7.2. Pull off temperature selector knob (18, fig. 1).

Unscrew the two retaining screws (RS) or push out the plastic retaining clips (where fitted) and remove T.C.B. from main switch circuit board by lifting up.

Reassemble in reverse order.

Carry out electrical checks (11.1).

Check operation of C.H. flow thermostat (11.9).

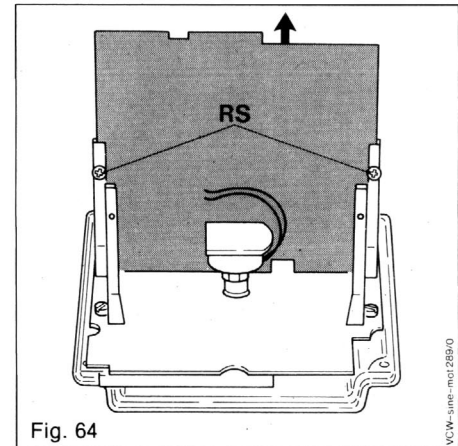

14.7.4 Change of flame supervision circuit board (F.S.C.B.) (Fig. 65)

Take off control box cover as under 14.7.1 and remove connections (C) of lock out red neon from F.S.C.B.

Unscrew retaining nut from lock out reset bottom (RN).

Disengage lock out reset button from control box cover and carefully unhook F.S.C.B.

Reassemble in reverse order.

Carry out electrical checks (11.1).

Check operation of flame supervision device (11.7).

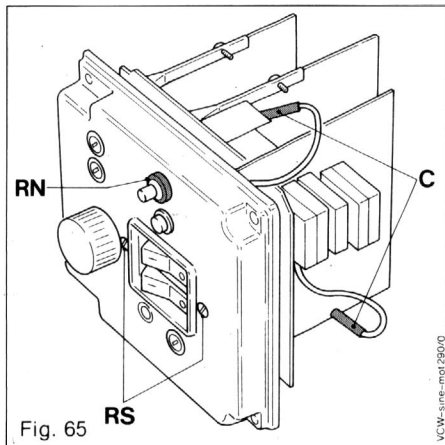

14.7.5 Change of main switch circuit board (M.S.C.B.) (Fig. 66)

Carry out operations 14.7.1, 14.7.2, 14.7.3 and 14.7.4.

Unscrew the two retaining screws (RS) as well as the two retaining screws (RS, fig. 65).

Reassemble in reverse order.

Carry out electrical checks (11.1).

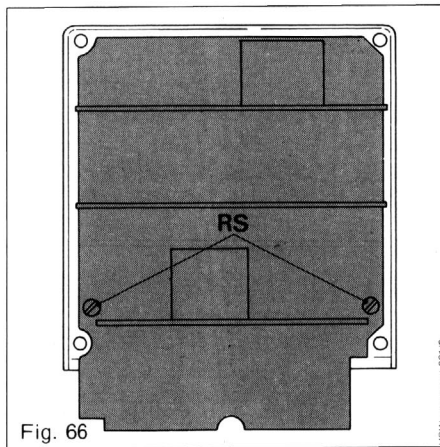

14.7.6 Change of diaphragm pump (Fig. 67)

Remove outer case as under 13.3.

Isolate the appliance from the electrical mains. Open the main terminal box (screw TS, fig. 62).

Unscrew the four retaining screws (FS, Fig. 57). Pull out complete control box to the front.

Mark and disconnect plastic hoses (PH) and push on connectors (AP).

Pull out diaphragm pump with rubber legs (RL) from control box bottom.

If necessary, access to the rubber legs inside the control box can be achieved by sliding out the control box cover completely with printed circuit boards (14.7.1).

Reassemble in reverse order.

Carry out electrical checks (11.1).

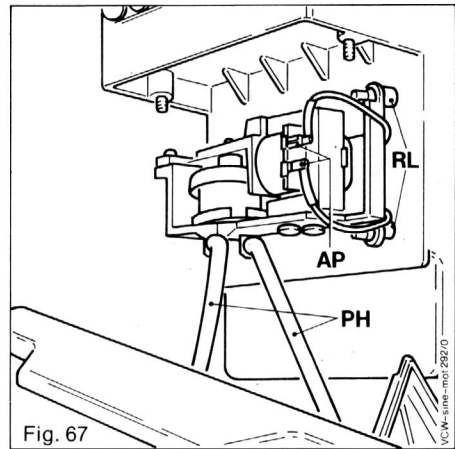

14.7.7 Change of ignition transformer (Fig. 68)

Isolate the appliance from the electrical mains.

Unscrew two retaining screws (RS, fig. 62). Securing the control box to appliance chassis. Pull complete box forward to release clip — the retaining chain will support the box.

Gently rotate box to gain access to the ignition transformer and remove retaining screw (RS, fig 68).

Note position of the cable connectors. Pull off high voltage leads (HVL), remove cable connectors and remove fixing screws (FS).

Reassemble in reverse order.

Carry out electrical checks (11.1).

Note:

Ensure that the earth cable (green/yellow) is connected to the earth terminal on the transformer.

14.7.8 Change of safety Isolating transformer

Open the control box as described in 14.7.1, but only remove the multiple plug connecting the transformer to the main switch circuit board. Temporarily replace the control box cover to prevent damage to the circuit boards.

Gain access to the rear of the control box by removing the retaining screws (RS, fig. 62) and pulling control box forward. Remove 4 screws securing the transformer to the rear of the control box.

Reassemble in reverse order taking care to replace the multiple plug onto the main switch circuit board.

Carry out electrical checks (11.1).

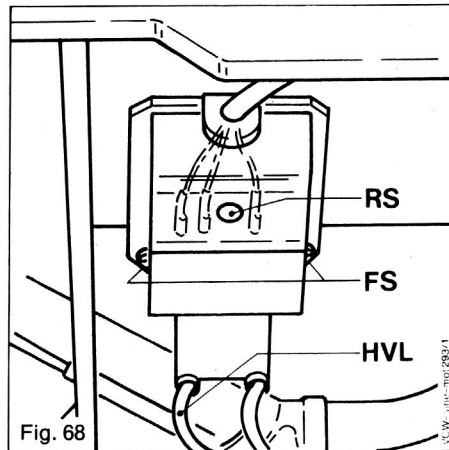

14.8 Change of overheat cut-off device (Fig. 69)

Isolate the appliance from the electrical mains.

Remove outer and inner case as under 13.3 and 13.4.

Remove left side wall of inner case by unscrewing the six retaining screws (RS).

Remove wire loop retaining the temperature sensor (TS) in the sensor pocket. Slide sensor upwards out of the pocket and draw through the rubber seal (S) in the rear side.

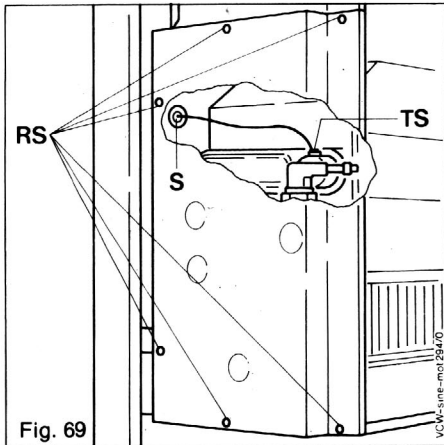

Remove the two retaining screws (RS, Fig. 70) and open protective housing (H) with screw driver in the slot between the two halves of the protective housing (fig. 70).

Unscrew the two fixing screws (FS). Clear overheat cut-off device from housing. Remove cable connectors.

Reassemble in reverse order.

Check — earth continuity
— polarity
— resistance to earth.

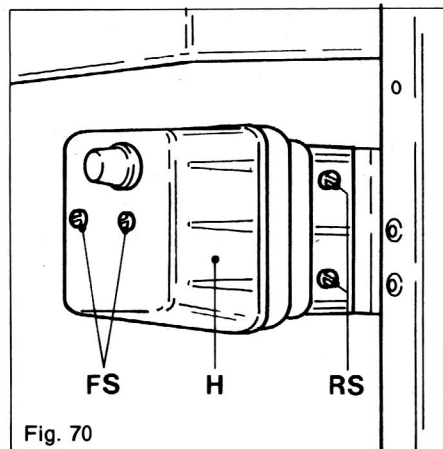

14.9 Change of fan (Fig. 71)

Isolate the appliance from the electrical mains.

Remove outer and inner case as under 13.3 and 13.4.

Remove side panel (R.H.S.) of inner case (6 screws).

Loosen 2 fixing screws (FS) as far as possible without removing completely. Gently expand the clamping ring by separating the clamping ring flanges using finger pressure.

Remove the 2 retaining screws (RS) and remove cover plate (C).

Gently lift fan motor vertically upwards a few millimeters to clear the spigot locating the fan onto the flue hood. Slide the fan motor downwards to disengage from the clamping ring.

Remove fan motor from the appliance taking care not to damage the small plastic impeller. Note position of cable connectors and remove connectors.

Reassemble in reverse order.

When reassembling, take care to engage fan motor onto the locating spigot on the flue hood, whilst inserting into the clamping ring. Do not overtighten clamping ring fixing screws (FS).

If the retaining screws (RS) for the cover plate (C) do not align, this indicates that the fan motor is not correctly located over the flue hood spigot. Do not overtighten screws RS.

Carry out electrical checks (11.1).

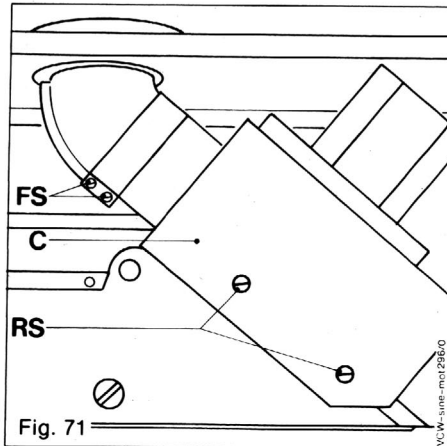

14.10 Change of air pressure switch (Fig. 72)

Isolate the appliance from the electrical mains.

Remove outer and inner case as under 13.3 and 13.4.

Remove the fixing screw (FS) and take out air pressure switch to the left hand side (Fig. 73).

Remove protective cover by unscrewing retaining screw (RS, Fig. 73).

Mark and disconnect plastic hoses (PH).

Remove connectors (A).

Reassemble in reverse order.

Check — earth continuity

- polarity
- resistance to earth.

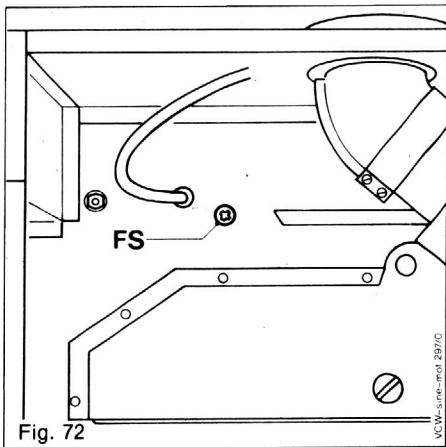

14.11 Removal of servo control valve assembly (Fig. 74)

Turn off the boiler (13.2).

Remove outer and inner case as under 13.3 and 13.4.

Drain the boiler as under 14.23 and 14.24

Slacken union nuts (M, fig. 75) and collect water in suitable container.

Note the connections of the four control lines (CL1 and CL2) to the servo control valve. Note the connections of the other ends of these control lines. Remove clamp (C1) by sliding upwards. Remove clamp (C2) by sliding outwards. The control lines are a push fit into the servo control valve. Disconnect the control line (CL1) from the servo control valve by gently pulling outwards. Remove control lines (CL2) from servo control valve. (Disconnect connections at other ends of

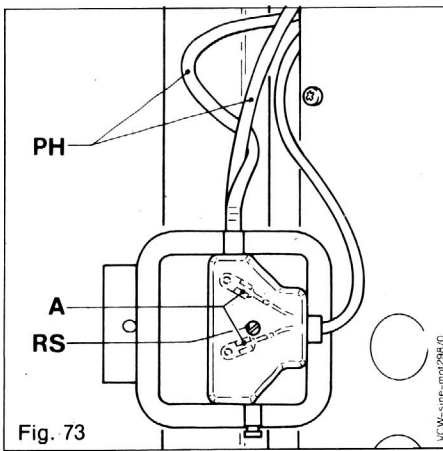

control lines to gain movement as necessary. Ensure all connections are noted to assist reassembly).

Unscrew the four union-nuts on the water section (M and N, fig. 75).

Remove the two retaining screws (RS, Fig. 74) securing the mounting bracket to the front of the appliance.

Remove the other two screws securing the bracket from underneath the appliance.

Remove the complete assembly downwards. Note position of cable connectors on the DHW micro switch and disconnect.

Reassemble in reverse order using new sealing washers.

Check — earth continuity

- polarity
- resistance to earth.

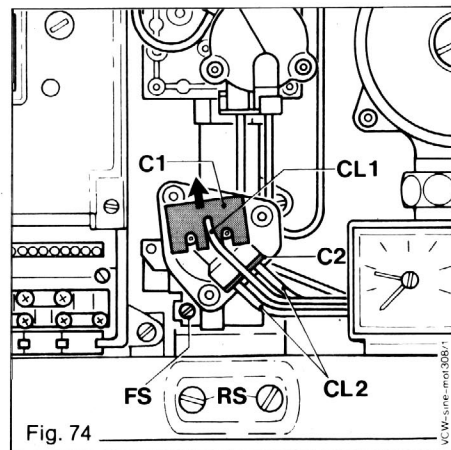

14.11.1 Change of servo control valve assembly (Fig. 74)

Remove complete assembly as under 14.11.

Separate the servo control valve assembly from the water section by removing fixing screw (FS, fig. 74) and sliding bracket sideways. Replace servo control valve assembly and replace fixing screw (FS, fig. 74). Check adjustment of servo control valve (14.11.4).

Reassemble in reverse order.

Carry out electrical checks (11.1).

14.11.2 Change of D.H.W. microswitch (Fig. 77)

Remove complete assembly as under 14.11.

Remove the two retaining screws (5), taking care not to loose the nuts.

Replace D.H.W. microswitch and check adjustment (14.11.4).

Reassemble in reverse order.

Carry out electrical checks (11.1).

14.11.3 Cleaning of water section (Fig. 75)

Remove outer case as under 13.3.

Turn off boiler as under 13.2.

Slacken union nuts (M, fig. 75) and collect water in suitable container.

Remove water section by unscrewing water connections (M and N, fig. 75) and loosening screw L.

Remove five screws securing the two halves of the water section, note position of components and separate.

Check diaphragm (P, fig. 76) and replace if necessary clean water filter (Q, fig. 76).

Check stuffing box and replace if necessary.

Reassemble in reverse order using new washers.

Note: If the complete water section is replaced it is necessary to check the adjustment of the servo control valve as under 14.11.4.

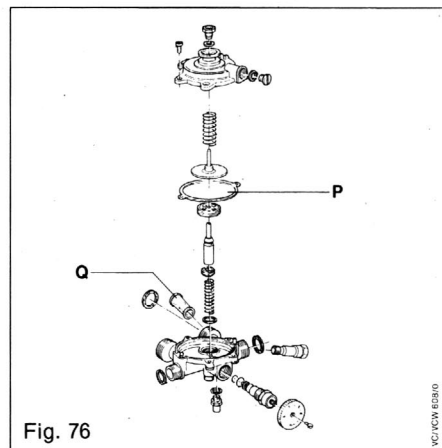
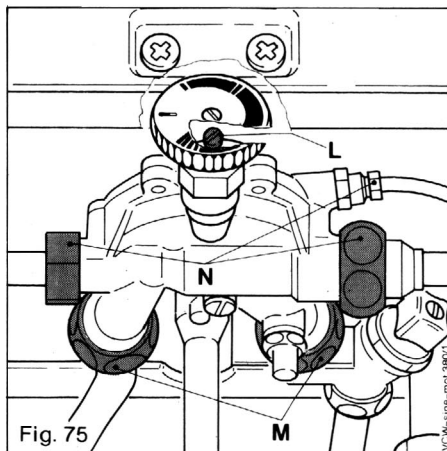

14.11.4 Adjustment of servo control valve (Fig. 77)

Remove servo control valve assembly (14.11).

Adjust the distance between push rod (1) and cam (2) to 0.2 mm slackening nut (3), turn push rod (1) and refasten nut (3). Rotate cam (2) to provide a 5-7 mm gap between the push rod (1) and cam (2).

Adjust the distance between micro-switch housing and spring plate (4) to 0.3 to 0.5 mm, using screws (5).

Reassemble in reverse order.

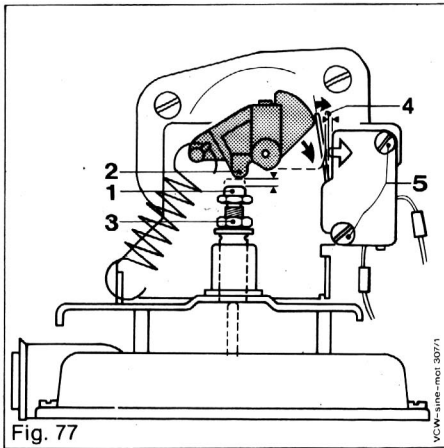

14.12 Change of expansion vessel

14.12.1 DHW expansion vessel (Fig. 78)

Remove outer case as under 13.3.

Turn off D.H.W. service cock.

Drain D.H.W.

Disconnect tubing nut (TN), unscrew bracket securing screw (SS) and remove expansion vessel.

Reassemble in reverse order.

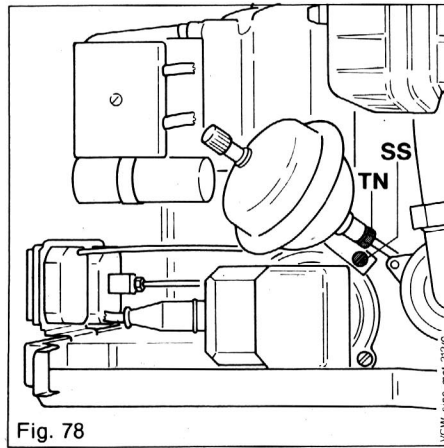

14.12.2 CH expansion vessel

In the unlikely event of a failure of the CH expansion vessel either procedure 14.12.2.1 or procedure 14.12.2.2 can be followed.

14.12.2.1 Air/flue duct assembly arranged to the rear and side (Fig. 79 and Fig. 80)

Turn off the boiler (13.2).

Remove outer and inner case as under 13.3 and 13.4.

Release CH system pressure as under 14.2.3

Isolate the appliance from the electrical mains. Disconnect external wiring as under 14.7.1. Remove air/flue elbow in reverse order to 9.7

Disconnect flow and return connections at compression joints on top of service cocks. Disconnect gas connection at compression joint on top of gas cock. Disconnect domestic hot and cold connection on water section.

Remove appliance from the wall. Remove 2 fixing clamps (FC, Fig. 80). Lift up and take out expansion vessel to the rear.

Reassemble in reverse order.

14.12.2.2 External replacement vessel

Alternatively, a suitable replacement expansion vessel can be fitted external to the boiler as described in 5.11.3

In these circumstances, the replacement expansion vessel must be correctly sized, ignoring the original expansion vessel which can be left in position on the boiler.

14.13 Change of thermometer (Fig. 81)

Remove outer case as under 13.3.

Pull the temperature sensor (TS) out of the sensor tube. Press the two tongues into the thermometer and pull it out to the front side.

Reassemble in reverse order.

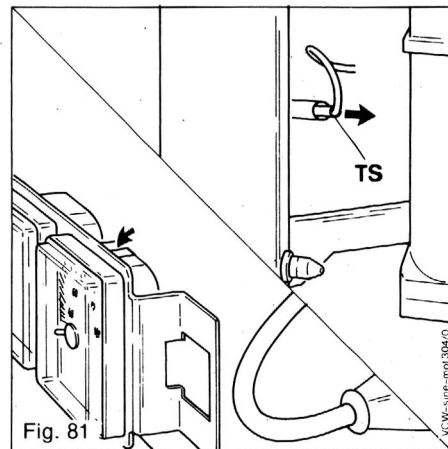
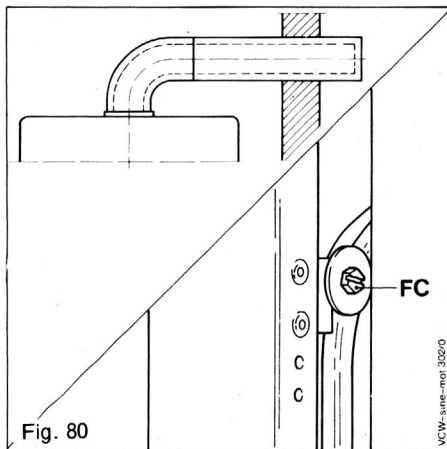
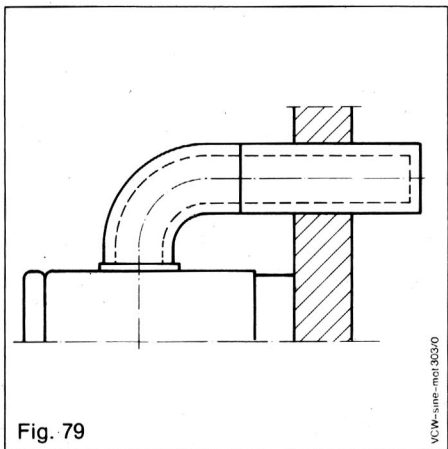

14.14 Change of pressure gauge (Fig. 82)

Turn off boiler (13.2).

Remove outer case as under 13.3.

Release CH system pressure as under 14.23

Disconnect the tubing nut (TN) of the control line and press the two tongues on the pressure gauge and pull it out to the front side.

Reassemble in reverse order.

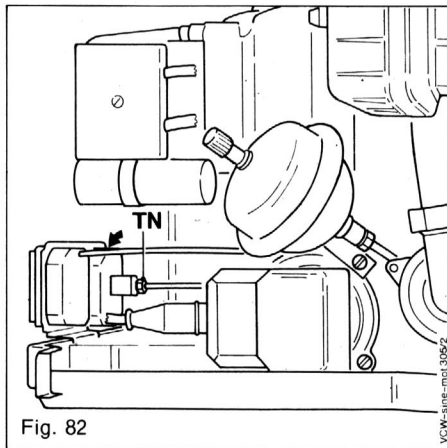

14.15 Change of system bypass (Fig. 83)

Turn off boiler as under 13.2.

Remove outer and inner case as under 13.3 and 13.4.

Release CH system pressure and drain boiler as under 14.23 and 14.24

Disconnect the two union nuts (V) and remove bypass valve. Access to the union nuts can be gained by removing the D.H.W. expansion vessel as under 14.12.1 and the diverter valve as under 14.4.3 if necessary.

Reassemble in reverse order using new washers.

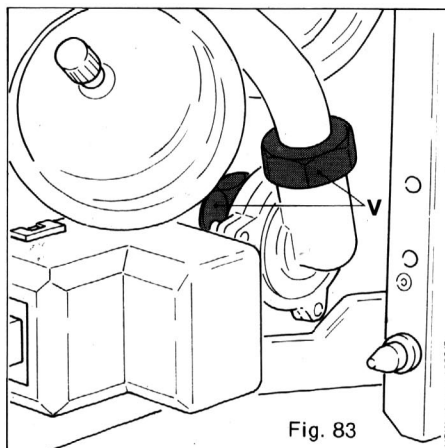

14.16 Change of domestic hot water overheat thermostat

Remove the outer case as under 13.3.

DHW overheat thermostat is located on the DHW outlet pipe from the DHW heat exchanger on the front, LHS of the boiler to the left of the control box.

Note position of cable connectors.

Remove the cable connectors (PL).

Remove the two screws (S) securing the thermostat to the pipe.
(Do not overtighten the thermostat).

Reassemble in reverse order.

14.17 Change of central heating overheat thermostat

The thermostat is located on the CH flow pipe at the bottom LHS of the boiler, to the rear of the DHW heat exchanger.

Remove the cable connectors.

Unscrew the thermostat from the flow pipe.

Reassemble in reverse order.

Do not overtighten the thermostat.

14.18 Change of domestic hot water pressure relief valve

Turn off the boiler as under 13.2.

Unscrew the pressure relief valve (D, fig. 40) and collect water in a suitable container.

Reassemble in reverse order, using new washers.

14.19 Change of central heating pressure relief valve

Turn off the boiler as under 13.2.

Remove the outer case as under 13.3.

Release CH system pressure as under 14.23

Remove the discharge pipe connection.

Unscrew the pressure relief valve from the return central heating service cock.

Reassemble in reverse order.

14.20 Change of D.H.W. heat exchanger (Fig. 85)

Turn off boiler as under 13.2.

Remove outer and inner case as under 13.3 and 13.4.

Drain the C.H. side off the boiler as under 14.23 and 14.24

Slacken both sleeve nuts on the lower front side of the D.H.W. heat exchanger and collect water in a suitable container.

Unscrew the four sleeve nuts (SN) and remove the D.H.W. heat exchanger.

Reassemble in reverse order using new washers.

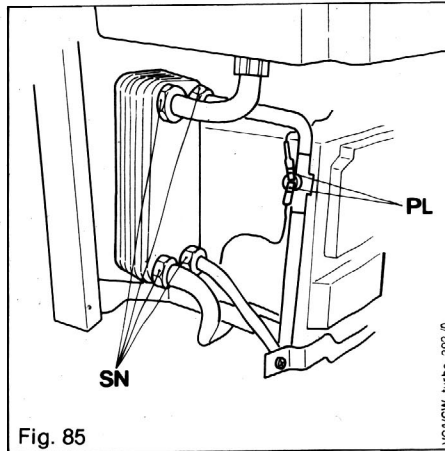

Fig. 85

VCV/CW-turbo 392 /0

14.21 Change of main heat exchanger

- Turn off boiler as under 13.2.
- Remove outer and inner case as under 13.3 and 13.4.
- Remove side panels of inner case (6 screws each side).
- Drain the boiler as under 14.23 and 14.24.
- Remove fixing screws (2) and take off cover sheet (3, Fig. 43).
- Remove securing means and pull out sensing element (4, Fig. 43) of overheat out of device.
- Disconnect union nuts (5, Fig. 43) on main heat exchanger and slide heat exchanger carefully forward and out.
- If necessary, replace heat exchanger.

- Reassemble in reverse order using new washers taking care to correctly locate heat exchanger.

14.22 Change of combustion chamber duct and insulation.

- Turn off the boiler as under 13.2.
- Remove outer and inner case as under 13.3 and 13.4.
- Remove side panels of inner case (6 screws each side).
- Carry out operation 13.6 to remove fan and flue hood.

- Carry out operation 13.5 to remove burner and burner bar.
- Remove burner support bracket (2 screws into back panel of inner case).
- Remove the two guide plates locating the main heat exchanger to the combustion chamber duct (3 screws each side, note plate position to assist reassembly).
- Remove 2 screws securing combustion chamber duct and lower away from main heat exchanger to remove.
- Replace combustion chamber duct complete with insulation.
- Reassemble in reverse order ensuring that the combustion chamber duct is positioned centrally under the heat exchanger before refitting the guide plates on each side.

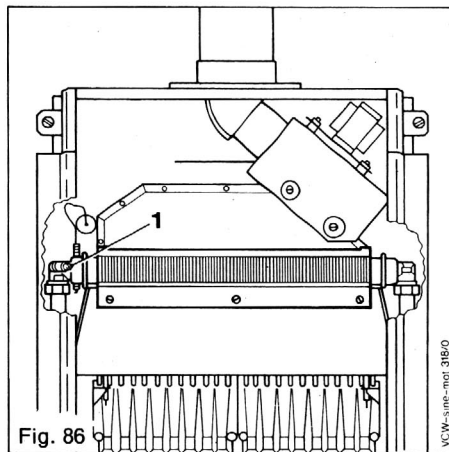

14.23 Releasing C.H. system pressure

Check C.H. service cocks are closed (4, Fig. 40).

Release pressure from the appliance by fitting a tube to a drain nipple (B, Fig. 40) and unscrewing one burn.

Drain water into a suitable container.

14.24 Draining boiler C.H. circuit

Release C.H. system pressure (14.23).

Drain the boiler by opening air vent (1, Fig. 87) and draining C.H. side of appliance through both drain nipples (B, Fig. 40).

Drain water into suitable container.

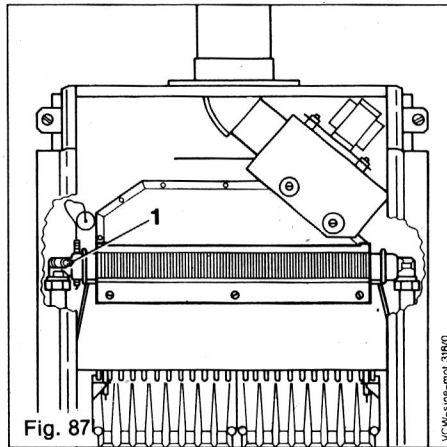

15 Fault Finding

Before proceeding, check the following:

- 1) Carry out preliminary electrical safety checks (see 11.1).
- 2) Turn ON external electrical supply and check external controls are calling for heat.
- 3) Turn ON gas supply and appliance gas service cock.
- 4) Check gas supply pressure at appliance.
- 5) Set boiler main switch to position 1 (ON).
- 6) Set heating switch to position 1 (ON).
- 7) Do not draw D.H.W.
- 8) Check lock out reset button is reset (push in black button on control box).

Always start fault finding procedure with sheet A and follow complete sequence through to sheet H.

Finally complete with electrical safety checks (see 11.1.).

Sheet A Check electrical supply

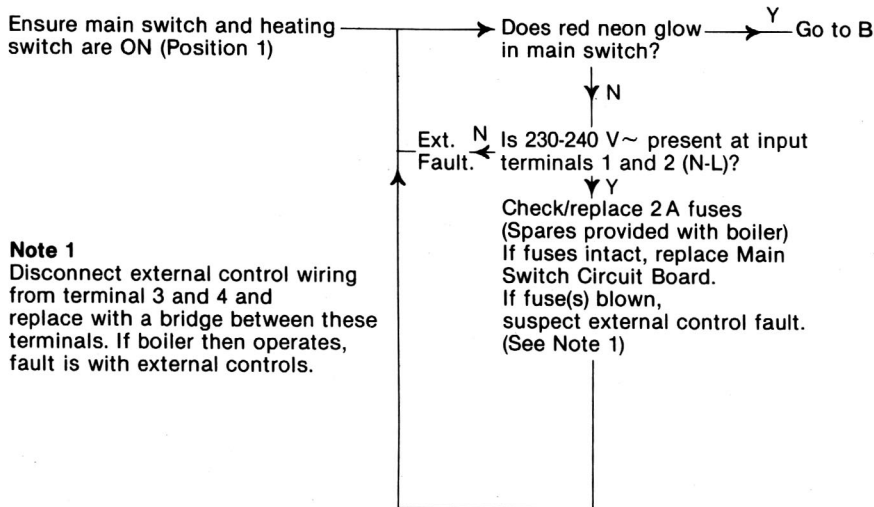

Note 1

Disconnect external control wiring from terminal 3 and 4 and replace with a bridge between these terminals. If boiler then operates, fault is with external controls.

Sheet B Check main switch and overheat cut-off device

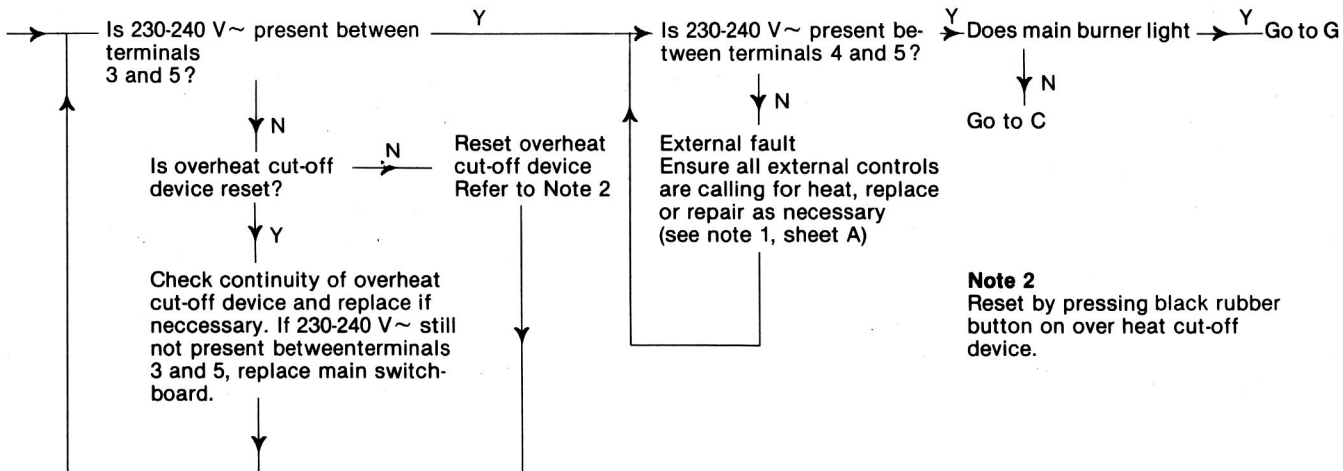

Note 2
Reset by pressing black rubber button on over heat cut-off device.

Sheet C Check operation of pump

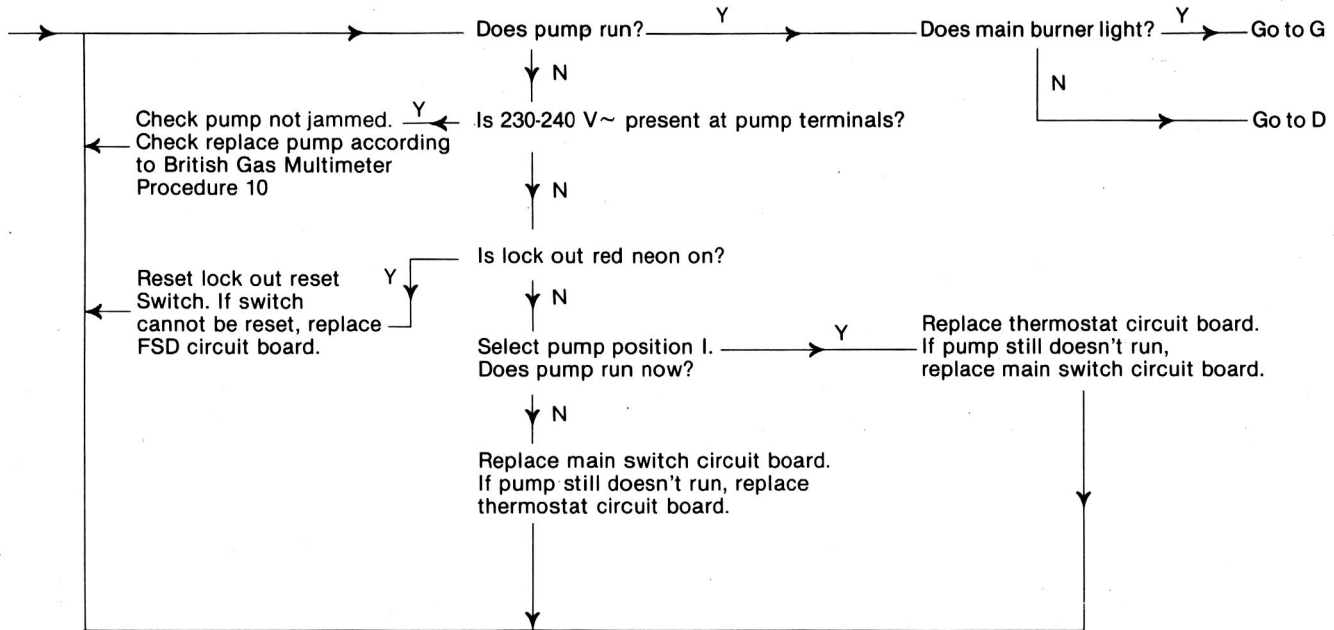

Sheet D Check Flue fan system

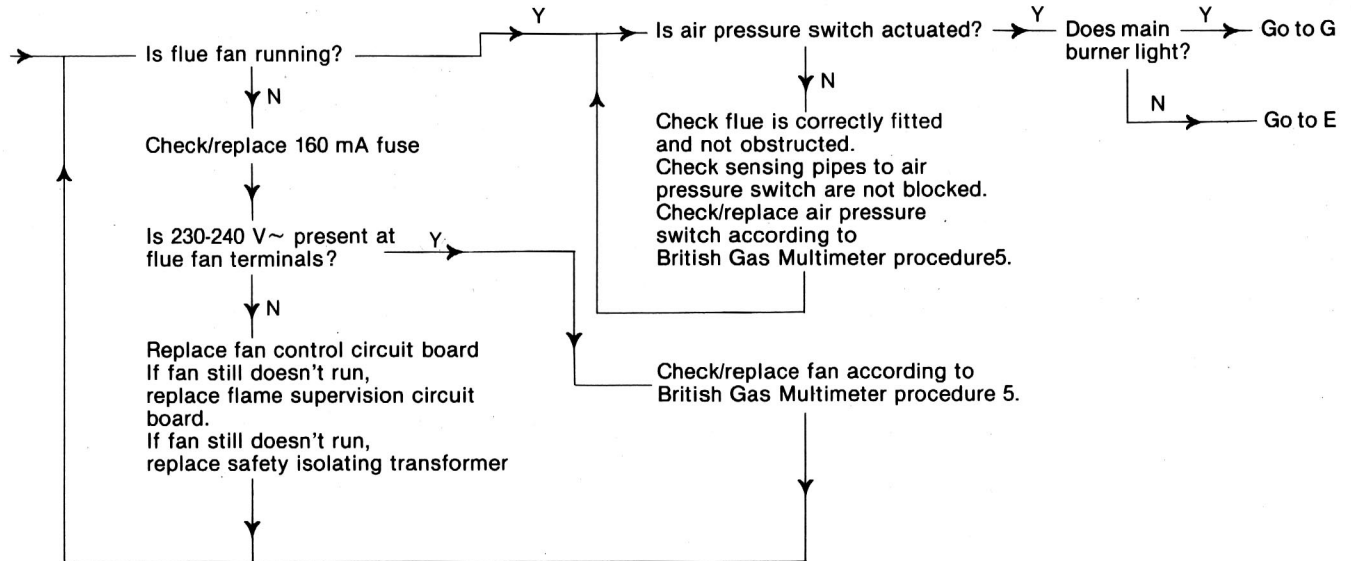

Sheet E Check operation of diverter valve

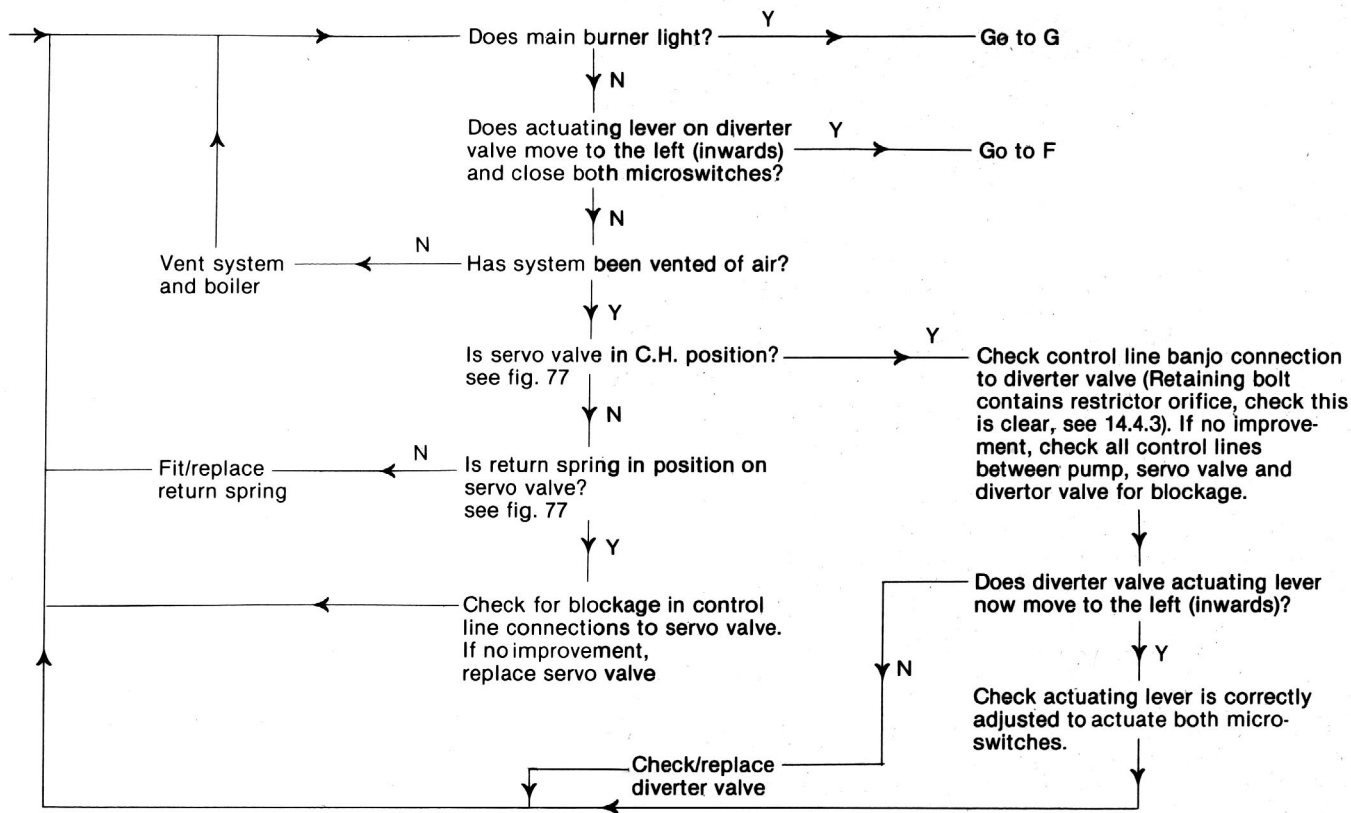

Sheet F Check Ignition system and gas section

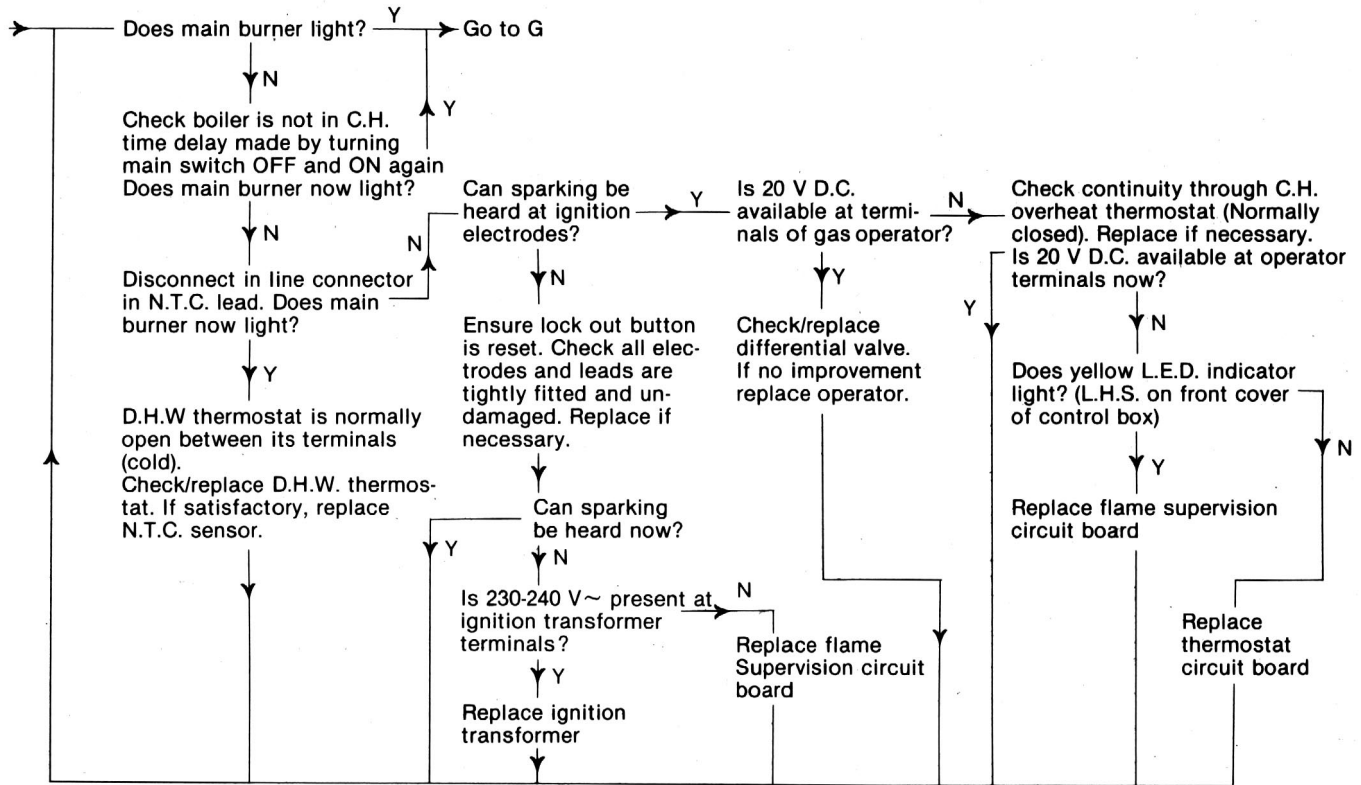

Sheet G Check burner modulation

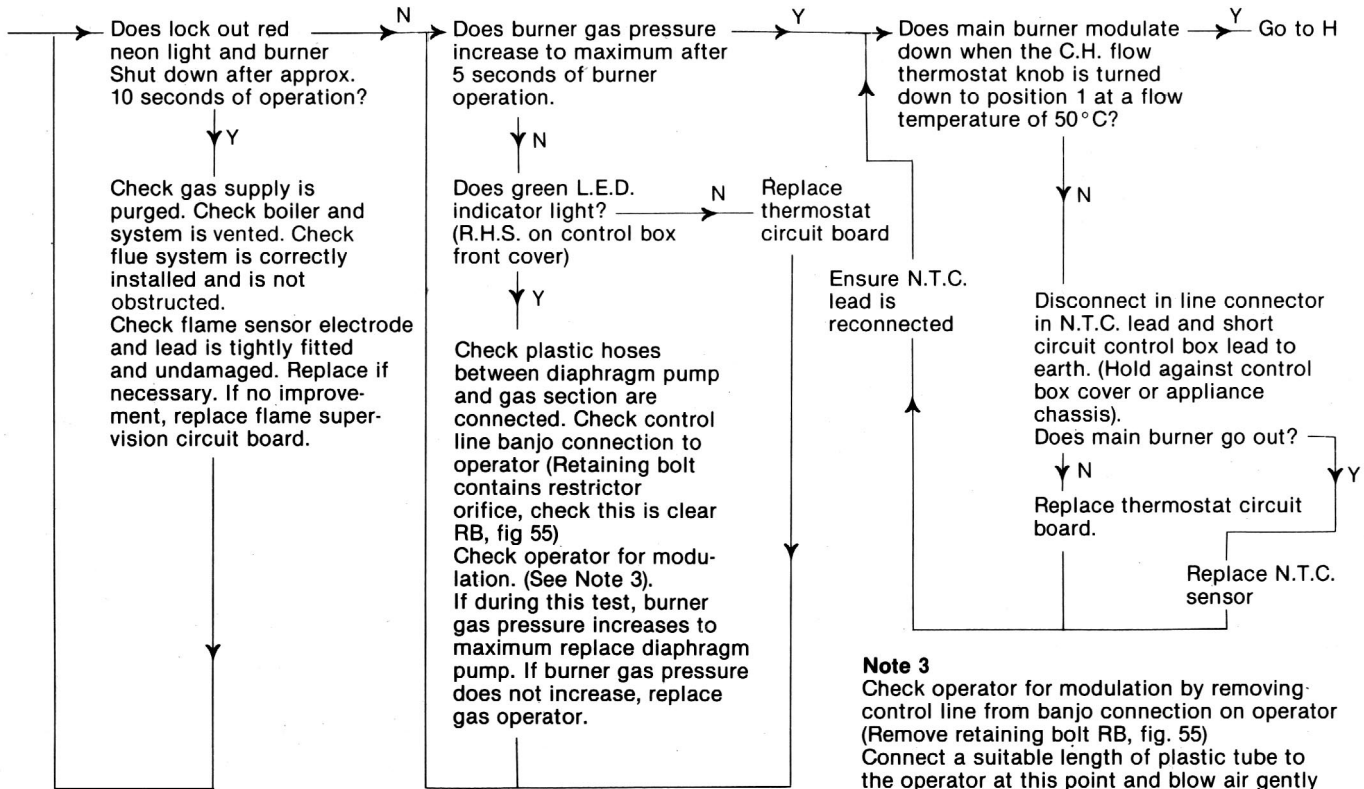

Note 3

Check operator for modulation by removing control line from banjo connection on operator (Remove retaining bolt RB, fig. 55) Connect a suitable length of plastic tube to the operator at this point and blow air gently into operator using mouth pressure only.

Sheet H Check D.H.W. operation

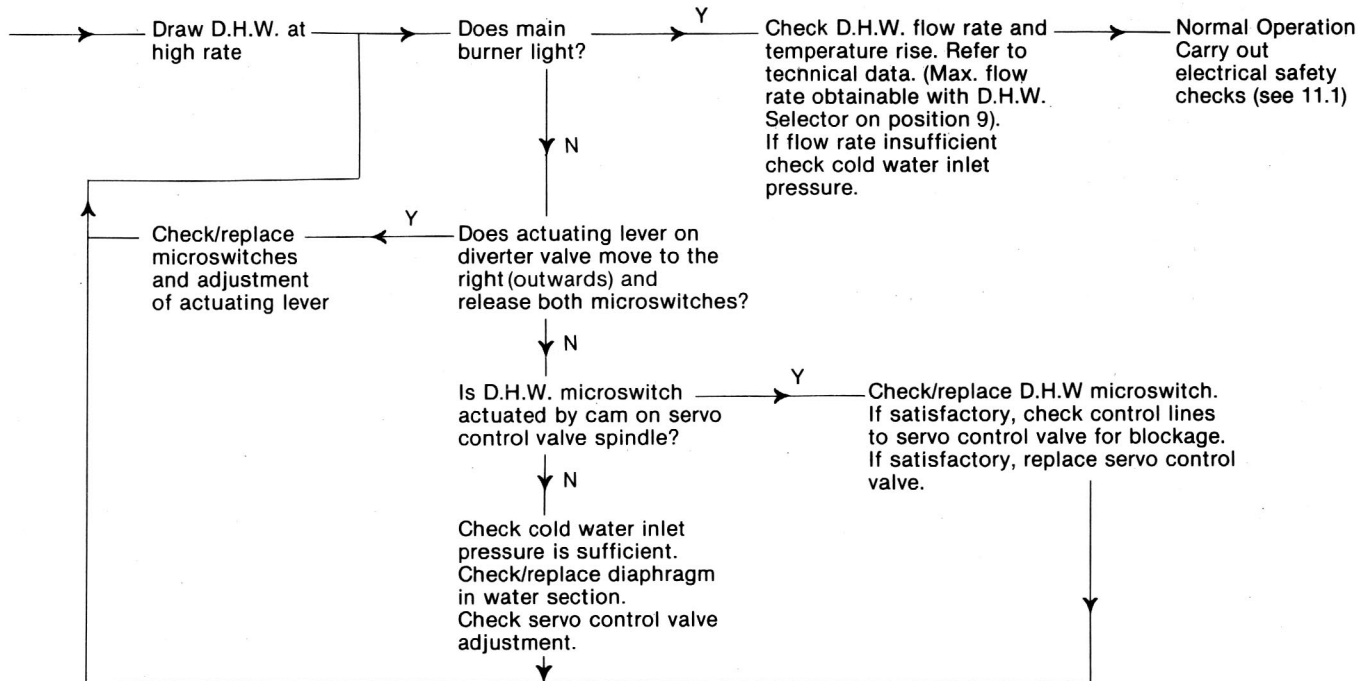

16 Electrical Diagrams

16.1 Functional Flow Diagram

Note: This diagram applies to boilers with "HY" marked on electronic control box front cover.

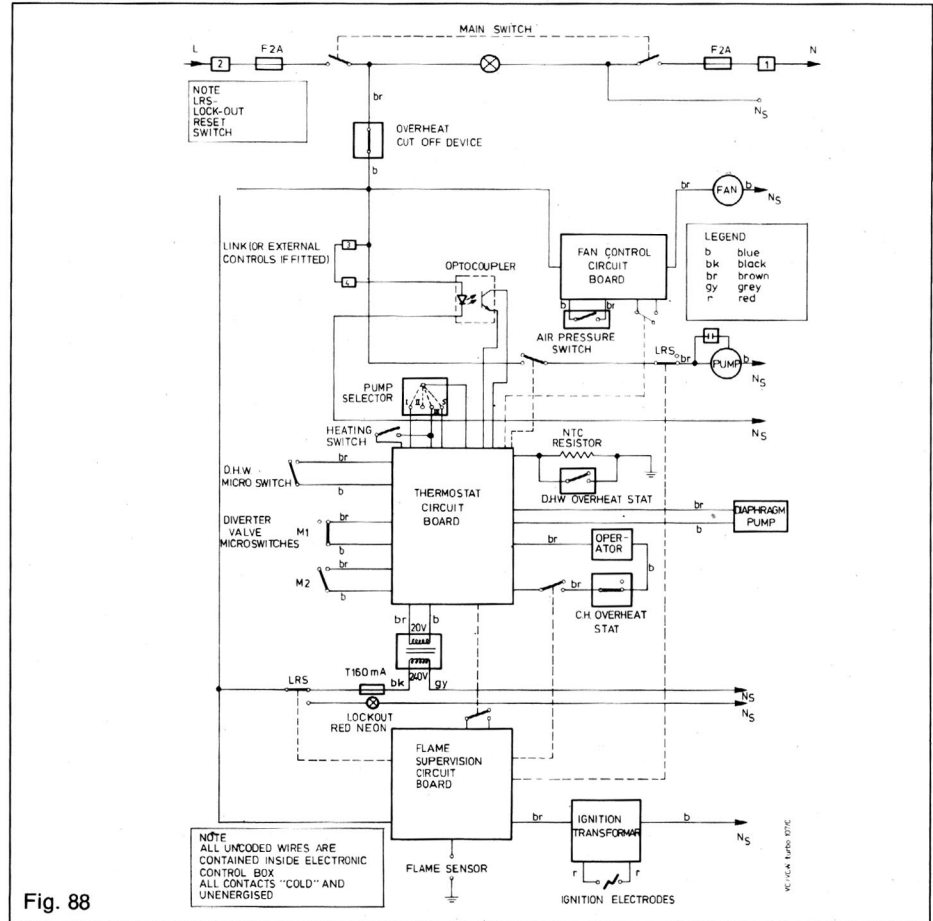

16.2 Wiring Diagram

Wiring diagram for VCW GB 242 EH
VCW GB 282 EH

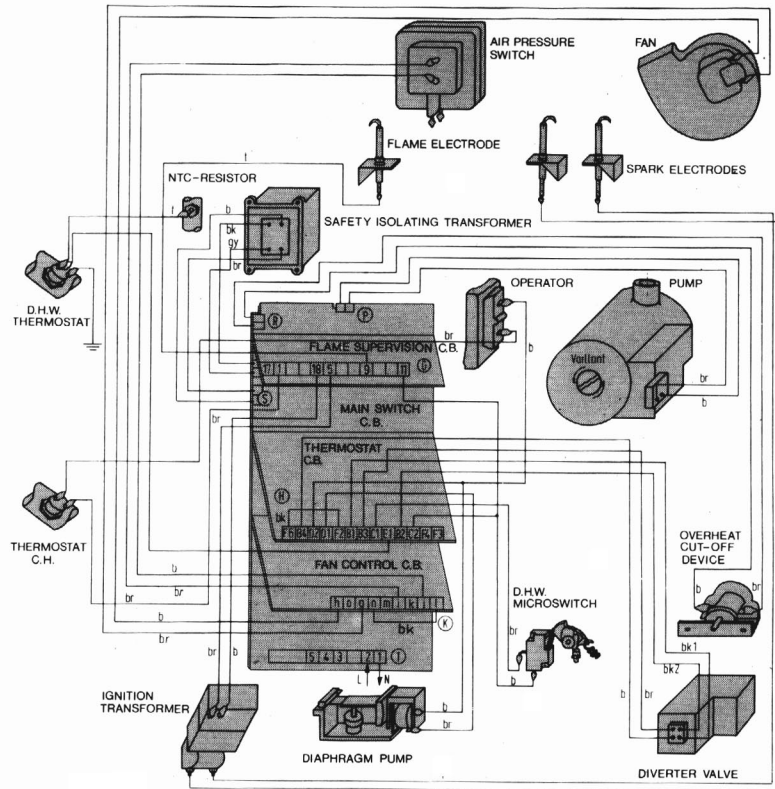

Legend

- br = brown
- b = blue
- bk = black
- r = red
- t = transparent

Fig. 90

VCW 812/1

17 Short part list

| Key No. | Description | | Part No. | G.C. No. |
|---------|---|---------|----------|----------|
| 1 | diaphragm | | 01-0318 | 262 329 |
| 2 | washer | | 98-0151 | 262 335 |
| 3 | burner chamber group | | 04-0468 | 255 212 |
| 4 | monitoring electrode | | 09-0649 | 255 213 |
| 5 | ignition electrodes | | 09-0665 | 255 215 |
| 6 | high tension lead | | 09-1513 | 255 222 |
| 7 | main heat exchanger | VCW 242 | 06-1836 | 255 235 |
| | | VCW 282 | 06-1872 | 264 123 |
| 8 | washer | | 98-1602 | 255 248 |
| 9 | washer | | 98-1609 | 255 249 |
| 10 | secondary heat exchanger | | 06-4947 | 283 585 |
| 11 | air pressure switch | | 05-0518 | 255 273 |
| 12 | flame supervision device | | 10-0522 | 255 335 |
| 13 | pressure gauge | | 10-1250 | 255 328 |
| 14 | thermometer | | 10-1542 | 255 327 |
| 16 | ignition transformer | | 09-1222 | 255 330 |
| 17 | auto. air vent. | | 06-1707 | 263 935 |
| 18 | packing ring | | 98-0287 | 262 316 |
| 19 | expansion vessel — (C.H.) | | 18-1022 | 255 346 |
| 20 | washer | | 98-0166 | 255 296 |
| 21 | expansion vessel — (D.H.W.) (if fitted) | | 18-1025 | 264 004 |
| 22 | screen plate | | 07-1469 | 255 255 |
| 23 | right hand side panel | | 07-3752 | 255 257 |
| 24 | left hand side panel | | 07-3751 | 255 264 |
| 25 | upper door | | 07-4095 | 255 265 |
| 26 | lower door | | 07-4094 | 255 266 |
| 27 | circulation pump (complete) | | 16-1068 | 255 300 |

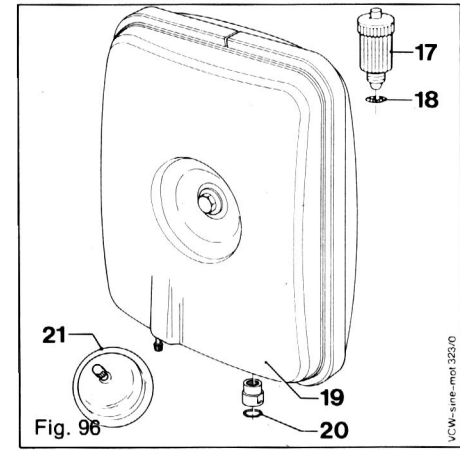
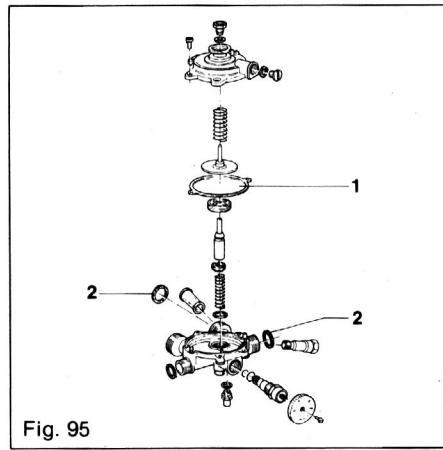
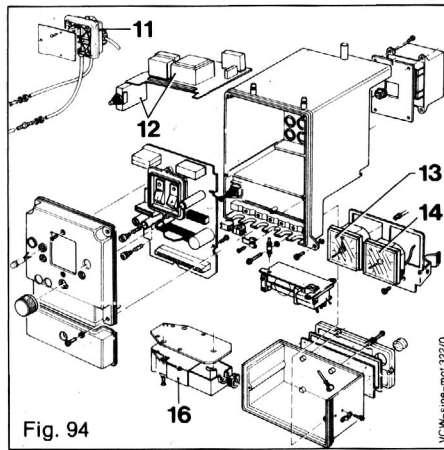
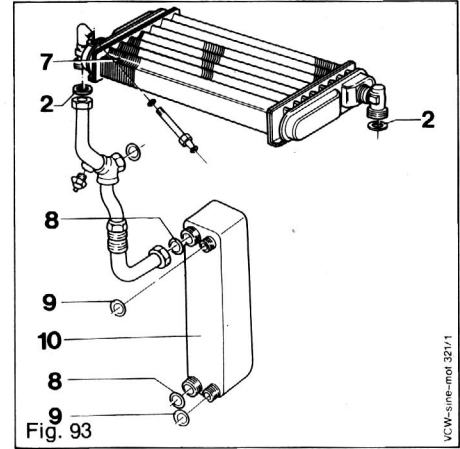
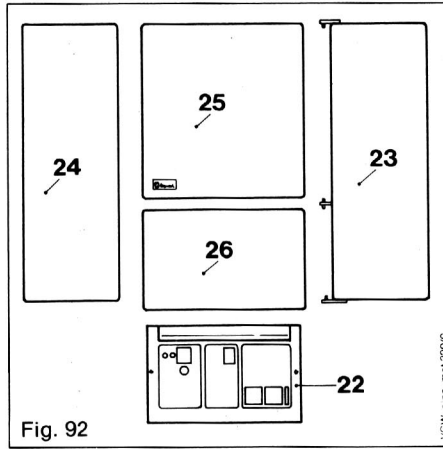
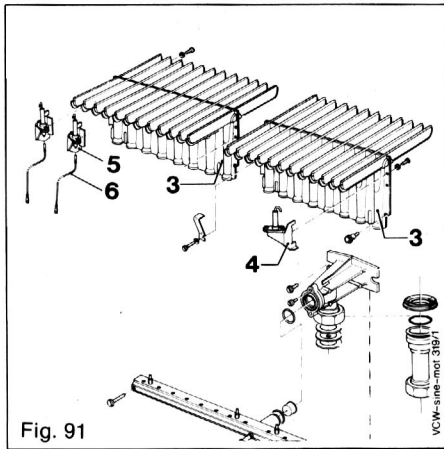

Supplement to instructions for installation 83 12 83

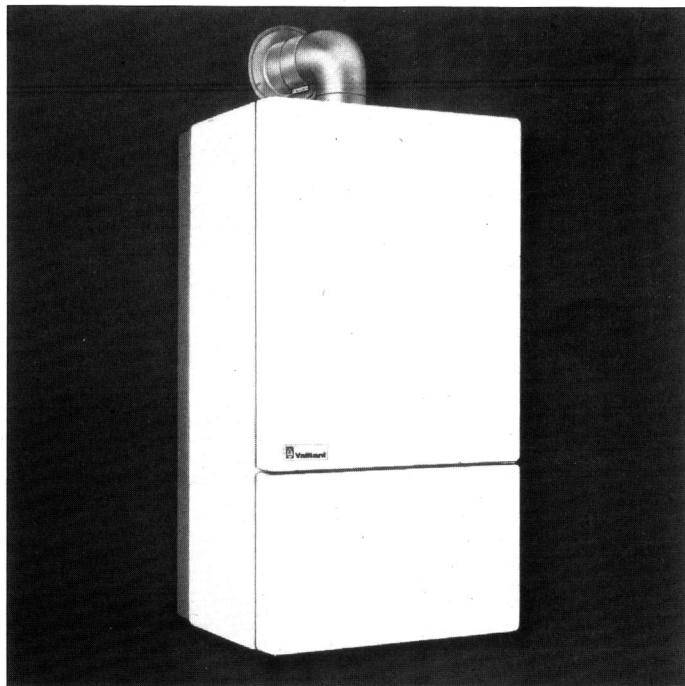

**Fan-assisted
Room Sealed type**

**Wall mounted
COMBIcompact®**

for central heating
and instantaneous
domestic hot water

VCWGB 242 E B

VCWGB 282 E B



HEATING, CONTROLS, HOT WATER.

The appliance delivered is designed for use with LPG.
Please read the instructions for installation therefore as follows:

Related documents to be supplemented by:
BS 5482: CP for domestic butane- and propane-gas-burning installations
Part 1: Installations in permanent dwellings

Inlet pressure: Propane
37 mbar (14.9 in W.G.)

Technical Data

| Type | VCW GB 242 E B | VCW GB 282 E B | |
|------------------------------|--------------------|--------------------|----------------------------------|
| Main burner jet size | 16 x 7/078 | 16 x 7/078 | number x mark. mbar (in W.G.) |
| Burner setting pressure | 23.0 (9.1) Propane | 24.0 (9.5) Propane | |
| Restrictor | 400 | 2310 | marking |
| Delivered gas | G 31 95.65 | | |
| Propane Gross C.V. (s.t.) | | | MJ/m ³ |
| Gas consumption (s.t.) | 1.1 | 1.32 | m ³ /h |

18 Technical data

¹⁾ For systems having a larger water capacity an additional expansion vessel can be installed easily.

²⁾ Higher DHW temp. rises can be achieved by adjusting the user selector (See user instructions).

We cannot accept responsibility for damage caused as a result of non-observance of these installation and servicing instructions.
Subject to alteration.



Head Office

Vaillant Ltd.,

Vaillant House,

Medway City Estate, Trident Close,
Rochester, Kent ME2 4EZ

Sales 01634-292310

Technical 01634-292392

Service Freephone 0800 -318076

Training 01634-292370

1195 V

Printed in Germany - Imprimé en Allemagne

Printed on 100% recycled paper

83 12 83 GB01

| Type | VCW GB 242 EH | VCW GB 282 EH | Units |
|---|--|--------------------------------------|--|
| Nominal heating output | 24 (81 900) (86.4) | 28 (95 500) (101) | kW (BTU/h) (MJ/h) |
| Nominal heating input (based on gross C.V.) | 29.6 (101 030) (106.6) | 35 (119 500) (126) | kW (BTU/h) (MJ/h) |
| Main burner jet size for NG | 16 x 7/140 | 16 x 7/140 | number x mark. |
| Burner setting pressure | 5.1 (2.05) 1.5 (0.6) | 6.8 (2.73) 0.6 (0.2) | mbar (in WG) |
| Minimum water flow for heating system 20 °C rise | 1030 (227) | 1200 (265) | l/h (imp. Gal./h) |
| Water capacity of heat exchanger | 0.57 (0.12) | 0.57 (0.12) | l/h (imp. Gall) |
| Pump pressure available for central heating system | 0.25 (8.4) | 0.25 (8.4) | bar (feet) |
| Max. nominal flow temperature | 90 (194) | 90 (194) | °C (°F) |
| Maximum total water capacity of heating system (cold ¹⁾ for sealed system | 90 (20) | 90 (20) | l (imp. Gal.) |
| Delivered gas Gross C.V. (s.t.) Gas consumption (s.t.) | G 20 37.8 (1014) 2.82 (1.66) | G 20 37.8 (1014) 3.33 (1.96) | MJ/m ³ (BTU/cu. ft) m ³ /h (c.f.m.) |
| Domestic water specifications to British standard Nominal output | 24 (81 900) | 28 (95 500) | kW (BTU/h) |
| Nominal temperature Minimum water pressure Flow rate (45 °C) | 65 (149) 0.65 (9.4) 10.0 (2.2) | 65 (149) 0.65 (9.4) 11.4 (2.5) | °C (°F) bar (P.S.I.) l/min. (gal/min.) |
| D.H.W. temp. rise ²⁾ 10 l/min. (2.2 gal/min.) flow rate, approx. water pressure required | 35 1.6 (23.2) | 40 1.6 (23.2) | (°C) bar (P.S.I.) |
| Water flow, min. | 3.5 (0.77) | 3.5 (0.77) | l/min. (gal/min.) |
| Water pressure required | 0.3 (4.4) | 0.3 (4.4) | bar (P.S.I.) |
| Max. water pressure | 10 (145) | 10 (145) | bar (P.S.I.) |
| Weight | 61.5 (136) | 61.5 (136) | kg (pound) |
| Electric connection | Voltage Input external Fuse internal Fuse | 230-240/50 135 3 0.16/2 | 230-240/50 180 3 0.16/2 |
| | | | V~/Hz W Amp Amp (slow) |