



The DFU Range

Installation and Servicing Instructions

WARNING: THIS APPLIANCE MUST BE EARTHED

CONTENTS

<i>Section</i>	<i>Title</i>	<i>Page</i>
1.	Introduction	2
2.	Technical Data	3
3.	General Requirements	5
4.	Installation	5
5.	Air Distribution System	6
6.	Commissioning & Testing	7
7.	Servicing	11
8.	Replacement of Faulty Components	11
9.	Connections to Powrmatic External Controls	13
10.	Fault Finding	14
11.	Short List of Parts	15

<i>Table</i>	<i>Title</i>	<i>Page</i>
1a.	Dimensions (S.I. Units)	3
1b.	Dimensions (Imperial Units)	3
2a.	Specifications (S.I. Units)	4
2b.	Specifications (Imperial Units)	4
3.	Burner Pressures - Natural Gas Group H - G20	4
4.	Gas Connection Sizes	4
5.	Profile Plate Pressures	4
6.	Electrical Loadings	4

<i>Figure</i>	<i>Title</i>	<i>Page</i>
1a.	Gas Control Schematic DFU 100	8
1b.	Gas Control Schematic DFU 250 - 1500	8
2a.	Gas Controls Layout DFU 100	9
2b.	Gas Controls Layout DFU 250 - 1000	9
2c.	Gas Controls Layout DFU 1500	10
3a.	Block Valve Layout DFU 100	10
3b.	Block Valve Layout DFU 250 - 1000	10
4.	Belt Tension Adjustment	12
5.	Limit Thermostat - Honeywell V4064N	13

1. Introduction

The Powrmatic DFU range of direct gas fired forced air heaters cover a heat input range of 29KW (100,000 Btu/h) to 440KW (1,500,00 Btu/h).

The heaters are intended primarily for heating commercial or industrial premises. There are, however, some limitations on application due to the presence of combustion products in the heated air and reference must be made to the Powrmatic publication 'Powrmatic Direct Fired Air Heaters - Notes for Guidance on Application and Installation' to ascertain if the intended application is acceptable.

The heaters may be installed so as to use 100% fresh air.

All the units are fired by a single direct fired gas burner, the firing rate being controlled by a modulating valve operating at the dictate of room or duct temperature. Safety functions are provided by a programming control.

DFU heaters are available in UF; UD; HF; HD; CF; CD, and EA variants. (U - Upright; H - Horizontal; F - Freeblowing; D - Ducted; C - Counterflow; EA - External Unit

Gas Safety (Installation and Use) Regulations (as amended) 1984
It is law that all gas appliances are installed by competent persons* in accordance with the above regulations. Failure to install appliances correctly can lead to prosecution. It is your own interests and that of safety to ensure that the law is complied with.

* e.g. Corgi Registered

2 Technical Data

2.1 Dimensions

DFU500UF SHOWN

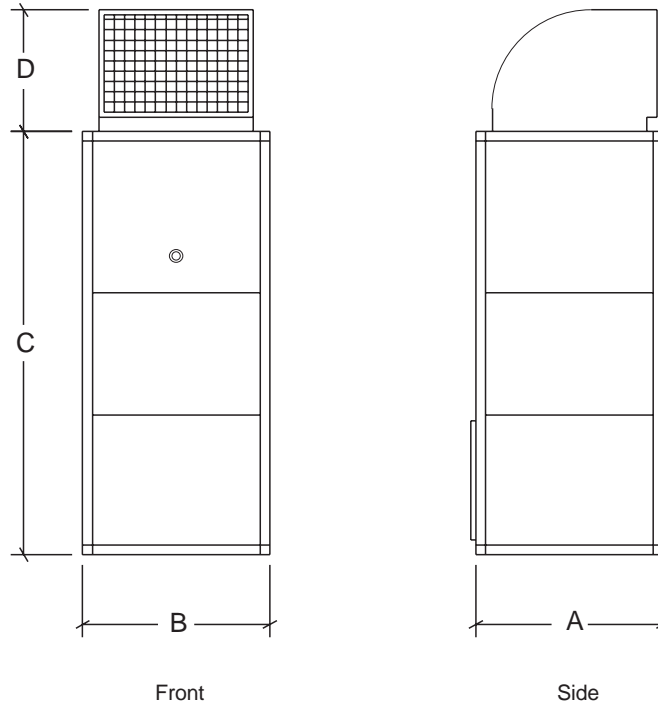

DFU1000UD SHOWN

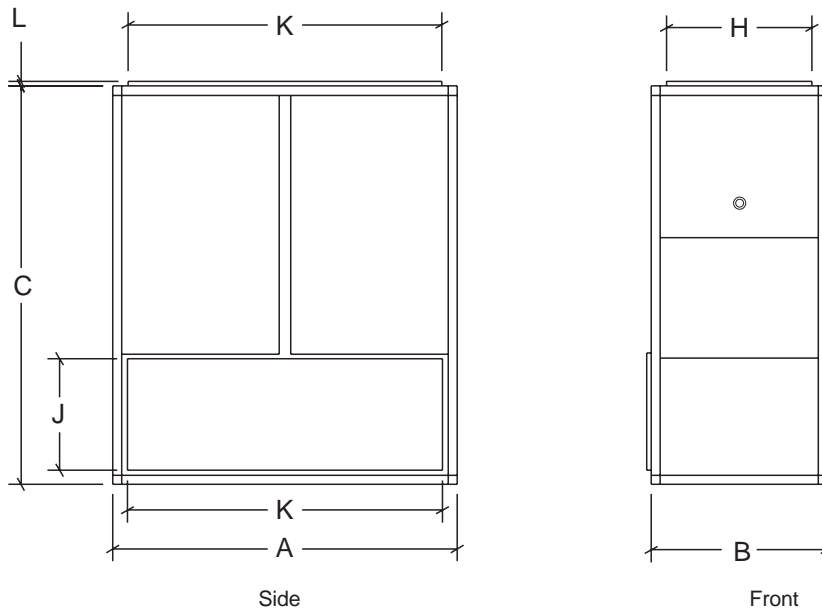

Table 1a. Dimensions (S.I. Units)

	A	B	C	D	H	J	K	L	
DFU 100	603	908	1645	390	765	425	765	51	
DFU 250	908		2051	590		610			575
DFU 500							1775		
DFU 750									
DFU 1000									
DFU 1500	2025	1162			2229		1018	610	1886

Table 1b. Dimensions (Imperial Units)

	A	B	C	D	H	J	K	L	
DFU 100	24	36	65	15	30	17	30	2	
DFU 250	36		81	23		40			23
DFU 500							70		
DFU 750									
DFU 1000									
DFU 1500	79¾	46			87¾		40	24	74¼

Table 2a - Specifications (S.I. Units)

MODEL	HIGH FIRE		LOW FIRE		AIR VOLUME	MAXIMUM DUCT RESISTANCE	FAN MOTOR	WEIGH
	INPUT (Nett)	OUTPUT	INPUT (Nett)	OUTPUT				
	kw		kw					
DFU 100	26.4	26.4	10.35	10.35	0.7550	1.25	0.18	134
DFU 250	66.0	66.0	18.83	18.83	1.1805	1.25	0.75	216
DFU 500	132.0	132.0	38.34	38.34	2.3611	1.25	1.5	218
DFU 750	198.0	198.0	73.79	73.79	3.5416	1.25	3.3	339
DFU 1000	264.0	264.0	76.47	76.47	4.7222	0.5	4.0	341
DFU 1500	396.0	396.0	213.96	213.96	7.0833	0.5	7.5	400

Table 2b - Specifications (Imperial Units)

MODEL	HIGH FIRE		LOW FIRE		AIR VOLUME	MAXIMUM DUCT RESISTANCE	FAN MOTOR	WEIGH
	INPUT (Gross)	OUTPUT	INPUT (Gross)	OUTPUT				
	Btu/h		Btu/h					
DFU 100	100000	90100	39188	35305	1600	0.5	0.25	306
DFU 250	250000	225250	71313	64248	2500	0.5	1.0	485
DFU 500	500000	450500	145200	130825	5000	0.5	2.0	485
DFU 750	750000	675740	279454	251788	7500	0.5	4.5	794
DFU 1000	1000000	901000	228962	260948	10000	0.2	5.5	794
DFU 1500	1500000	1351500	810268	730050	15000	0.2	10.0	882

Table 3 Burner Pressures - Natural Gas - Group H - G20

MODEL	Burner Type	Burner Port Diameter	Pilot Gas Pressure		High Fire				Low Fire			
					Burner Pressure		Gas Rate		Burner Pressure		Gas Rate	
					mbar	in wg	m³/h	ft³/m	mbar	in wg	m³/h	ft³/m
DFU 100	Midco 2"	3.0	N/A	N/A	13.6	5.4	2.8	97.1	2.04	0.8	1.09	38.50
DFU 250	Midco 6"		7.1	2.8	13.8	5.5	6.9	243	1.0	0.4	1.91	67.45
DFU 500	Midco 12"		7.1	2.8	12.9	5.2	13.7	485.2	1.1	0.45	4.05	143.02
DFU 750	Midco18"		7.1	2.8	11.9	4.8	20.6	728.8	1.6	0.6	7.80	275.46
DFU 1000	Midco 24"		7.1	2.8	11.5	4.6	27.5	970.1	1.2	0.48	8.08	285.35
DFU 1500	Midco 36"		7.1	2.8	11.2	4.5	41.2	1455.3	3.1	1.2	22.61	798.47

Table 4 Gas Connection Sizes

	DFU 100	DFU 250	DFU 500	DFU 750	DFU 1000	DFU 1500
Gas Inlet Connection	R½	R1	R1	R1½	R1½	R2

Table 5 Profile Plate Pressures

			DFU 100	DFU 250	DFU 500	DFU 750	DFU 1000	DFU 1500
Profile Plate Pressures	High	mb	+1.9	+2.4	+2.2	+1.6	+1.3	+5.7
	Low		-0.1	-0.1	-0.2	+0.4	+0.4	+0.2

Table 6 Electrical Loadings

MODEL	Standard					
	ph	MOTOR R.P.M.	PLATE AMPS (A)	START AMPS (A)	RUN AMPS (A)	FUSE RATING (A)
DFU 100	3	1425	0.7	1.8	0.7	2
DFU 250			1.9	4.3	1.6	3
DFU 500			3.5	8.5	3.2	5
DFU 750			7.4	22.0	6.3	10
DFU 1000			9.2	26.0	8.5	10
DFU 1500			14.6	13.5	14.6	15

3 General Requirements

3.1 Related Documents

The installation of the air heater(s) must be in accordance with the relevant requirements of the Gas Safety (Installation and Use) Regulations, 1984 and The Building Regulations and I.E.E. Regulations for Electrical Installations.

It should also be in accordance with relevant requirements of the local gas region, local authority and fire authority and the relevant recommendations of the following documents.

British Gas Plc Publications

IM/11 : 1989 Flues for Commercial and Industrial Gas Fired Boilers and Air Heaters

IM/16 : 1988 Guidance notes for the installation of gas pipework, boosters and compressors in Customer's premises (excluding domestic installation of 25mm and below).

British Standards

BS 6230:1991 'Specification for installation of gas fired forced air heaters for commercial and industrial space heating of rate input exceeding 60KW (2nd family gases)'.

British Standards Code of Practice

BS 5720: Code of practice for mechanical ventilation and air conditioning in buildings.

BS 5925: Code of practice for design of buildings; ventilation principles and designing for natural ventilation.

IM/16: 1988 Guidance notes for the installation of gas pipe work, boosters and compressors in customers premises (excluding domestic installations of 25mm and below)

EH 22: Health and Safety Executive Guidance Note 1979 Ventilation of Buildings (fresh air requirements).

3.2 Location

The location chosen for the air heater must permit the provision of an adequate air supply, space for servicing and air circulation around the heater.

The air heater must be installed strictly in accordance with the fire regulations of insurance company's requirements appertaining to the area in which the heater is located. The air heater must not be located in an area which is either hazardous or liable to concentrations of flammable vapours in excess of their threshold limit values, as defined in BS 5925.

Where the location of the air heater is such that it might suffer external mechanical damage e.g. from overhead cranes, fork lift trucks etc., it must be suitably protected.

DFU units are designed to operate at in a maximum ambient temperature of 30°C.

3.3 Gas Supply

3.3.1 Service Pipes

The local gas region should be consulted at the installation planning stage in order to establish the availability of an adequate supply of gas. An existing service pipe must not be used without prior consultation with the local gas region.

3.3.2 Meters

A gas meter is connected to the service pipe by the local gas

region of local gas region contractor. An existing meter should be checked preferably by the gas region, to ensure that the meter is adequate to deal with the rate of gas supply required.

3.3.3 Installation Pipes

Installation pipes should be fitted in accordance with IM/16:1988. Pipework from the meter to the air heater must be of adequate size. Do not use pipes of a smaller size than the inlet gas connection of the heater. The complete installation must be tested for soundness as described in the above code.

3.3.4 Boosted Supplies

Where it is necessary to employ a gas pressure booster the controls must include a low pressure cut off switch at the booster inlet. The local gas region must be consulted before a gas pressure booster is fitted.

3.4 Air Supply

Direct fired air heaters utilize a proportion of the air volume from the main air moving fan as air for combustion. It is therefore essential that air flow both into and out of the heater is not impeded in any way.

Reference must be made to Powrmatic publication 'Powrmatic Direct Fired Air Heaters - Notes for Guidance on Application and Installation' and to BS 6230 1991 to ensure that air supply requirements are fully understood and complied with.

3.5 Air Distribution System

DFU air heaters are not intended for use with excessive lengths of inlet ducting, the resistance of which may reduce the total airflow through the heater thereby affecting combustion performance. If in any doubt regarding the suitability of a proposed ductwork system Powrmatic Ltd. should be contacted for further advice.

3.6 Electrical Supply

Wiring external to the heater must be installed in accordance with I.E.E. Regulations for electrical installations and any local regulations which apply. Wiring should be completed in flexible conduit.

All heaters are supplied as standard for 400V 3N, 50Hz operation.

The method of connection to the main electricity supply must facilitate complete electrical isolation of the air heater(s). The method of connection should be provided adjacent to the air heater(s) in a readily accessible position. Means for electrical isolation, having a contact separation of at least 3mm in all poles, has to be provided. *See the wiring diagram accompanying these instructions.*

4 Installation of Air Heater(s)

4.1 General

Before installation, check that the local distribution conditions, nature of gas and and pressure, and adjustment of the appliance are compatible.

DFU U*, H* and C* variants are for internal use only. DFU EA* variants are for external use only.

The air heater must be installed in accordance with the rules in force and the relevant requirements of any fire regulations or insurance company's requirements appertaining to the area in which the heater is located, particularly where special risks

are involved such as areas where petrol vehicles are housed, where cellulose spraying is carried out, in wood working departments etc.

Whichever method of mounting the air heater is used the following minimum clearances for installation and servicing must be observed.

Rear of heater to nearest wall	0.5m (1.6ft)
Clearance at R.H.S. (looking at front of heater)	1.00m (3.3ft)
Clearance at L.H.S. (looking at rear of heater)	1.00m (3.3ft)
Front of heater	1.00m (3.3ft)
Top of heater to ceiling	1.00m (3.3ft)

DFU EA* heaters must be installed on a purpose designed plinth or frame work to suit the site conditions. In addition the plinth or framework must ensure that the lowest point of any air entry point into the heater is at least 500mm above the ground or roof level.

Any combustible material adjacent to the air heater and the flue system must be so placed or shielded as to ensure that its temperature does not exceed 65 °C (150 °F)

IMPORTANT: No air heater shall be installed where there is a foreseeable risk of flammable particles, gases vapours or corrosion inducing gases or vapours being drawn into either the heated air stream or the air for combustion. In such cases installation may only proceed if the air to be heated and the air for combustion are ducted to the heater from an uncontaminated source preferably outside the building. In certain situations where only airborne particles are present it may suffice to fit filters on the air inlet ducts of the heater. Advice in these instances may be obtained from Powrmatic Ltd.

4.2 Fitting of Air Heater(s)

Floor mounted heaters must be installed on a level noncombustible surface.

Roof Top and suspended heaters must be installed either on specifically designed cradles or platforms that are capable of adequately supporting the weight of the unit (*See Tables 2a and 2b, Page 4*) and allowance must be made for any ancillary equipment. Before installing the heater any existing trusses, walls, brackets etc., must be inspected to ensure they are suitable. All supports should be protected against the effects of rust or corrosion. The means of mounting should also provide for service access wherever possible.

If noise levels are of particular importance the heater should be insulated from the structure of the building by installing it on suitable anti-vibration mountings. In all such cases and, in addition, when the heater is suspended it is essential that all gas, duct and electrical connections to the heater are made with flexible connections to maintain continuity of connection.

4.3 Gas Connection

To facilitate disconnection of the heater from the incoming gas supply pipework a union type service valve must be fitted at the inlet to the heater. The gas supply to the air heater, run to an adjacent point and adequately supported, should then be connected to the servicing valve in either solid pipework or by suitable flexible connection of an approved type.

4.5 Gas Connection

A servicing valve and downstream union must be fitted at the inlet to the air heater gas controls assembly to facilitate

servicing . The gas supply to the air heater must be completed in solid pipework that is suitably protected from the elements and be adequately supported.

WARNING

When completing the final gas connection to the heater do not place undue strain on the gas pipework of the heater.

4.6 Electrical Connections

All units are fully pre-wired and only require final connections for the incoming mains supply and completion of the control circuit (230V) via a room thermostat, time clock etc. The electrical supply must be run to a point adjacent to the heater and be suitably terminated to provide an isolation point that will prevent remote activation of the unit during servicing. The heater electrical panel is located within the burner compartment and cable entry points are provided in the adjacent heater framework. Reference must be made to Table 6 (*Page 5*) to ascertain the electrical loading of the air heater(s) being installed so that cables of adequate cross-sectional area to safely carry that load are used for the electrical installation. The length of the conductors between the cord anchorage and the terminals must be such that the current carrying conductors become taut before the earth conductor if the cable or cord slips out of the cord anchorage. All external controls must be of an approved type.

5 Air Distribution System

5.1 General

DFU *D models are designed for use with duct work to more precisely define the point of air delivery, and/or provide ducted return air or ducted fresh air inlet. All ducting must be independently supported of the air heater. Joints and seams of supply ducts and fittings must be securely fastened and made airtight.

5.2 Noise Reduction

If deemed necessary consideration should be given to mounting the heater on resilient pads, or equivalent, to minimise transfer of noise and vibration to the structure of the building.

It is recommended that ducting should be connected to the heater spigots via an airtight flexible coupling of noncombustible material. Before fitting coupling it must be ensured that a maximum clearance of 13mm (1/2") will be maintained between the ends of the ducting and the heater spigots.

If required sound attenuators may be fitted in inlet and outlet ducts to reduce airborne fan noise. Materials used in outlet sound attenuators must be capable of withstanding 100 °C air temperature without any deterioration.

5.3 Room Thermostat Siting

The room thermostat(s) should be fitted at the point which will be generally representative of the heated area as far as temperature is concerned. Draughty areas, areas subjected to direct heat e.g. from the sun, and areas where the air movement is relatively stagnant e.g. in recesses, are all positions to be avoided for siting the thermostat.

The thermostat(s) should generally be mounted about 1.5m (5ft) from the floor. Any thermostat, frost thermostat, time clock etc. must be suitable for switching 230V 10amp and must be of the 'snap action' type to minimise contact bounce.

For electrical connections see the wiring diagram accompanying these instructions.

6 Commissioning and Testing

6.1 Electrical Installation

Checks to ensure electrical safety should be carried out by a competent person.

6.2 Gas Installation

The whole of the gas installation, including the meter, should be inspected and tested for soundness and purged in accordance with the recommendation of IM/16:1988.

6.3 Air Distribution System

The system should be checked to ensure that the installation work has been carried out in accordance with the design requirements. Particular attention should be given to the correct arrangement of delivery ducts and registers, return air ducts and grills and general adequacy of return air paths.

For DFU *D heaters ensure that the total duct system resistance does not exceed the available air pressure of the equipment supplied refer to *Tables 2a & 2b (Page 4)*. If the duct system resistance is less than the available air pressure of the equipment supplied additional resistance must be introduced e.g. by adjustment of duct outlet nozzles and balancing of the duct system.

6.4 Lighting the Air Heater

6.4.1 Gas Controls Assembly - Soundness Check

1. Ensure that the gas service valve at the inlet to the gas controls assembly is shut.
2. To prove soundness of the first safety shut off valve:-
 - a) Connect a pressure gauge to the inlet pressure test point on the main block valve or inlet pipework.
 - b) Open the gas service valve and allow pressure to stabilise before shutting it again. The valves are sound if no pressure drop is observed. If a pressure drop is observed do not proceed until the fault has been rectified. Remove pressure gauge and refit sealing screw in pressure test point.

6.4.2 Sequence Check

1. Ensure that the gas service valve is **closed** and that the main electrical supply to the heater is switched off.
2. Check that all external controls are either "ON" or at "MAX"
3. Turn "ON" the main electrical supply and check that the following sequence of events occurs.
 - i) Main fan runs
 - ii) Ignition spark is heard
 - iii) Pilot gas valve open (Main gas valves on DFU100).
 - iv) Burner goes to lockout as there is no gas supply.
4. Switch off main electricity supply.

6.4.3 Final Adjustment

6.4.3.1 DFU 100

1. Remove the sealing screw from the pressure test point located on the gas inlet to the burner head (*Fig 2a - 4*) and attach a pressure gauge.
2. Turn "ON" the main electricity supply and check that the following sequence of events occur.
 - i) Main air fan runs.
 - ii) Ignition spark is heard

- iii) Main gas valves open
- iv) Main gas flame is established.

3. Go to Section 6.4.3.3

6.4.3.2 DFU 250 - 1500

IMPORTANT: DFU 250 - 1000 - the maximum flow and start gas flow adjustments provided on the main gas valve (*Fig 2c - 1b and Fig 3b - 4*) are not used and must not be adjusted.

1. Remove the sealing screw from the pressure test point located on the pilot gas line (*Fig 2b/c - 7*) and attach a pressure gauge.
2. DFU 250 - 1000 Remove the electrical supply plugs from the main gas valves (*Fig 2b - 1*).
DFU 1500 - Remove the link between terminals *18 and 19*.
3. Turn "ON" the main electricity supply and check that the following sequence of events occur.
 - i) Main air fan runs.
 - ii) Ignition spark is heard
 - iii) Pilot gas valve opens
 - iv) Pilot gas flame is established.
4. Check that the pilot gas pressure agrees with that in Tables 3.1 or 3.2. If necessary adjust the start gas pressure (*Fig 2b/c - 6*).
5. Turn "OFF" the main electricity supply.
6. DFU 250 - 1000 Refit electrical supply plugs to the main safety shut-off valves.
DFU 1500 - Refit the link between terminals 18 and 19.
7. Turn "ON" the main electrical supply and the controls will run through their sequence until main flame is established.
8. Go to Section 6.4.3.3

6.4.3.3 Main Burner Adjustment

1. Check that the main burner gas pressure agrees with that in Tables 3.1 or 3.2. If necessary adjust the main burner gas pressure as follows.
2. Remove the cover from the modulating gas valve (*Fig 2a/b/c - 2*) situated within the control panel of the heater and identify the two adjustment potentiometers (POT 1 and POT 2)

Warning: Live electrical terminals (24V) are now exposed, proceed with caution.

NOTE: Always adjust the High fire potentiometer (POT 1) first.

6.4.3.3.1 Heaters fitted with a Duct Thermostat

1. Remove the cover from the duct temperature sensor and connect a temporary link between terminals 2 and 4. Set the TEMP 2 potentiometer to 95°C.
2. Adjust Pot 1 on the modulating gas valve to obtain the required High Fire burner pressure - this is normally adjusted to fully clockwise. (*See Tables 3.1, 3.2*). If the correct pressure cannot be obtained with the modulating valve fully open (check position by reference to the position of the indicator disc - 90° = fully open, 0° = fully closed) then the main gas governor requires adjustment.
 - a) DFU 250 - 1000
Release the governor cover screw and swing back cover. Adjust burner pressure by turning the governor adjustment screw, clockwise to increase, anticlockwise to decrease.
 - b) DFU 1500
Remove the governor cover screw (*Fig 2c - 13*). Adjust burner pressure by turning the governor adjustment screw, clockwise

Fig 1a. Gas Control Assembly Schematic - DFU 100

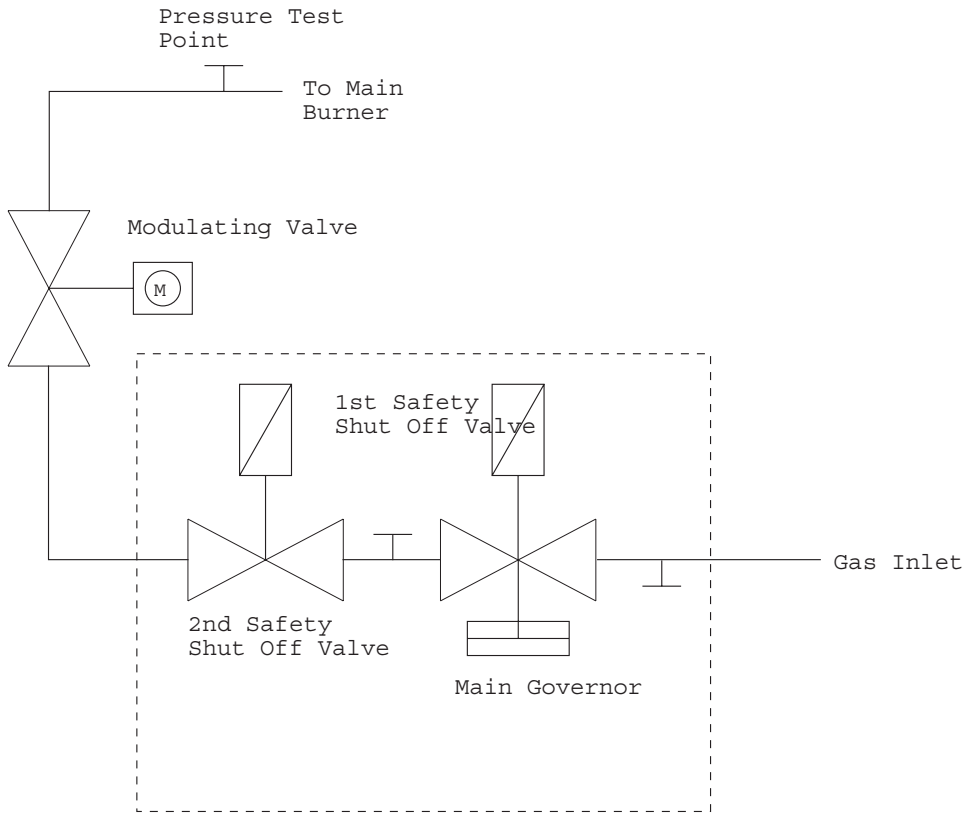

Fig 1b. Gas Control Assembly Schematic - DFU 250 - 1500

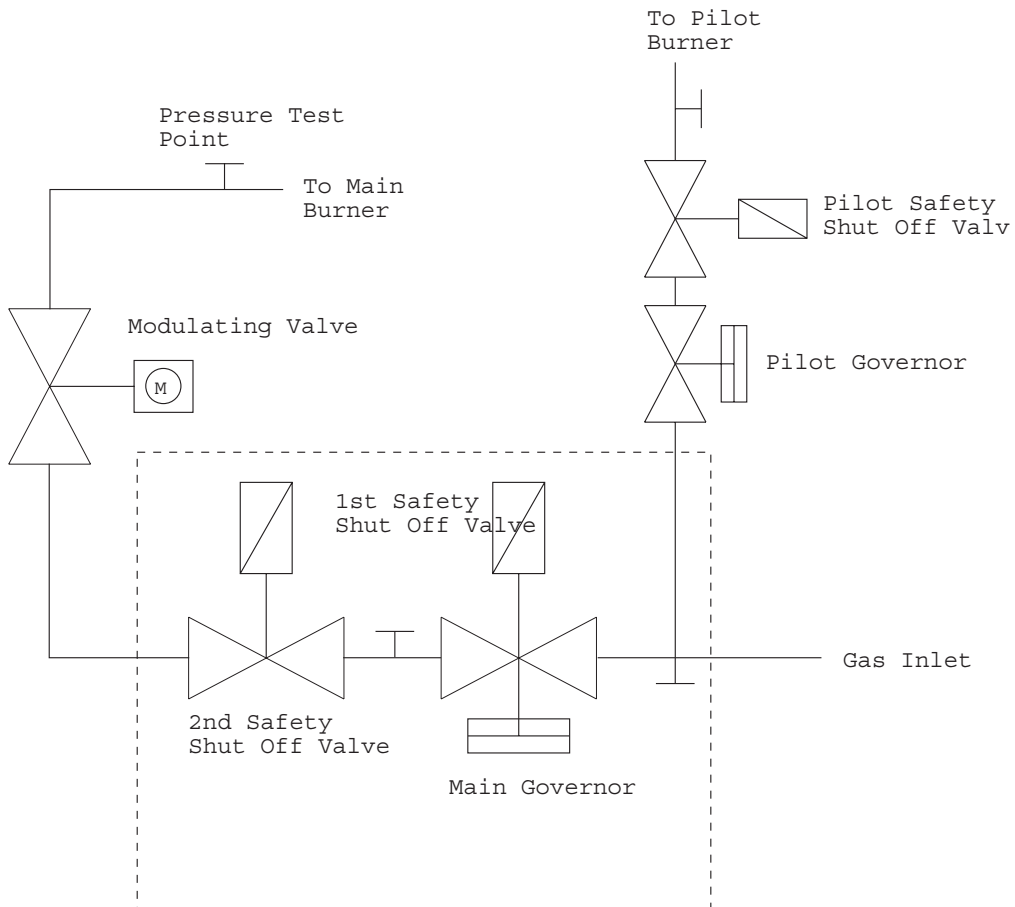

Fig 2a Gas Controls Layout DFU 100 - 1000

- 1a. 1st Main Gas Safety Shut Off Valve
- 1b. 2nd Main Gas Safety Shut Off Valve
- 2. Modulating Valve Head
- 3. Modulating Valve Body
- 4. Main Burner Pressure Test Point
- 5. Inlet Pressure Test Point
- 6. Main Terminal Strip
- 7. Programming Control Unit
- 8. Pressure Switch
- 9. 230V/24V Transformer

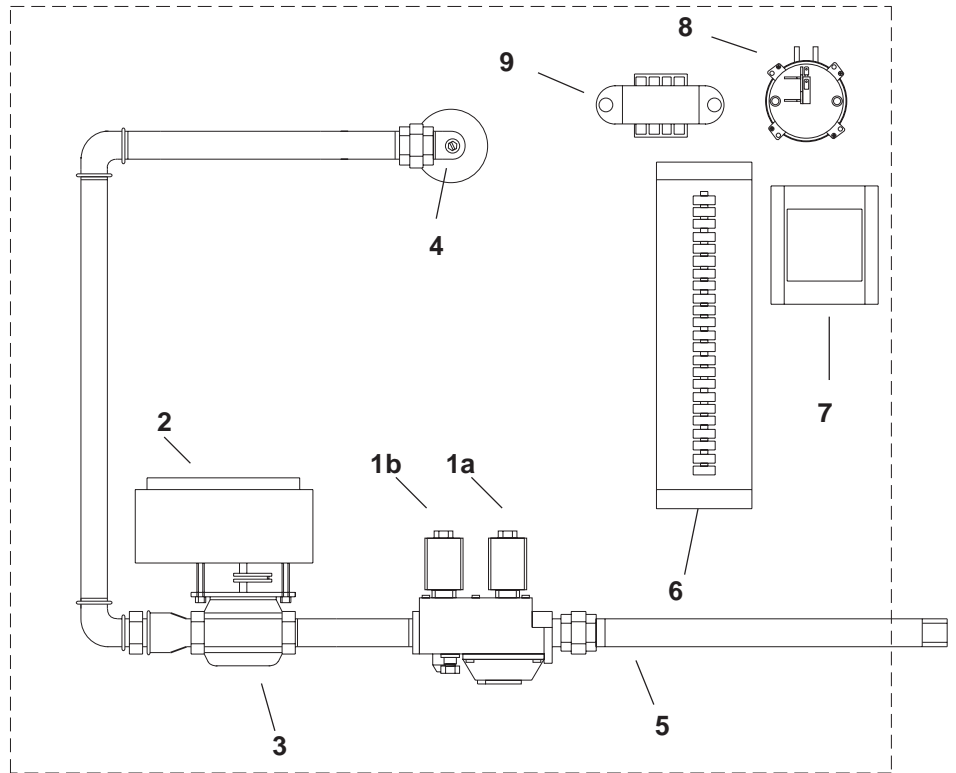

Fig 2b Gas Controls Layout DFU 250 - 1000

- 1. Main Gas Safety Shut Off Valve Block
- 2. Modulating Valve Head
- 3. Modulating Valve Body
- 4. Main Burner Pressure Test Point
- 5. Pilot Gas Valve
- 6. Pilot Governor
- 7. Pilot Pressure Test Point
- 8. Inlet Pressure Test Point
- 9. Main Terminal Strip
- 10. Programming Control Unit
- 11. Pressure Switch
- 12. 230V/24V Transformer

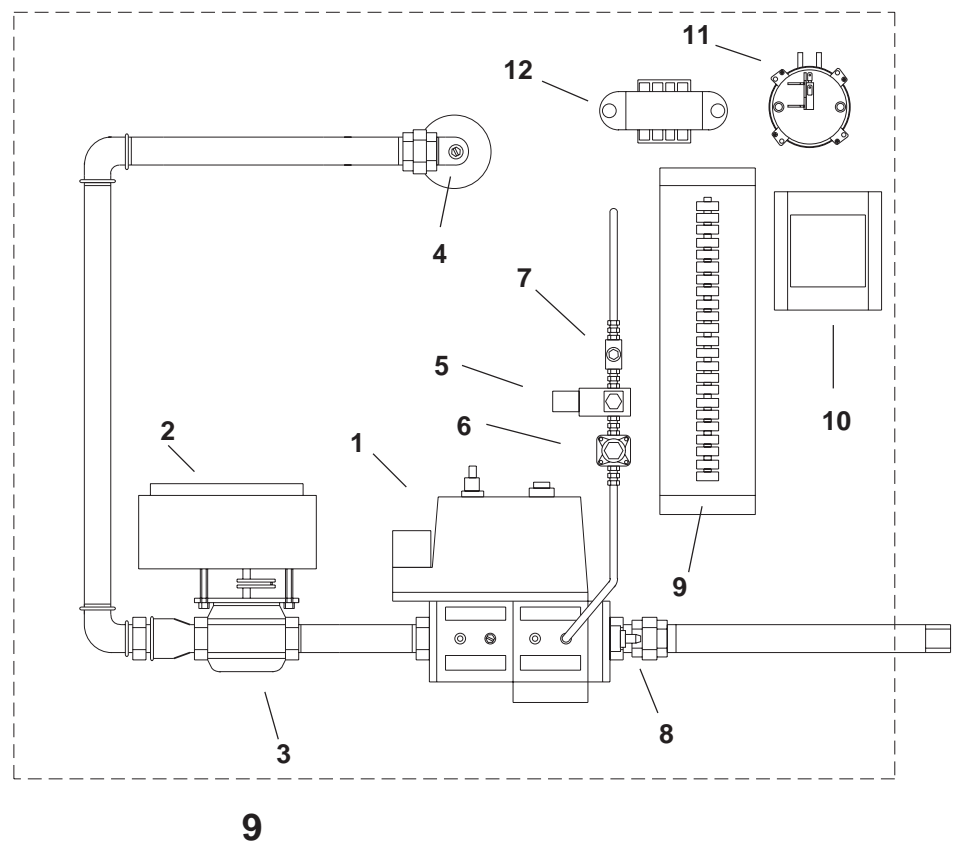

Fig 2c Gas Controls Layout DFU 1500

- 1a. 1st Main Gas Safety Shut Off Valve
- 1b. 2nd Main Gas Safety Shut Off Valve
- 2. Modulating Valve Head
- 3. Modulating Valve Body
- 4. Main Burner Pressure Test Point
- 5. Pilot Gas Valve
- 6. Pilot Governor
- 7. Pilot Pressure Test Point
- 8. Inlet Pressure Test Point
- 9. Main Terminal Strip
- 10. Programming Control Unit
- 11. Pressure Switch
- 12. 230V/24V Transformer
- 13. Main Gas Governor

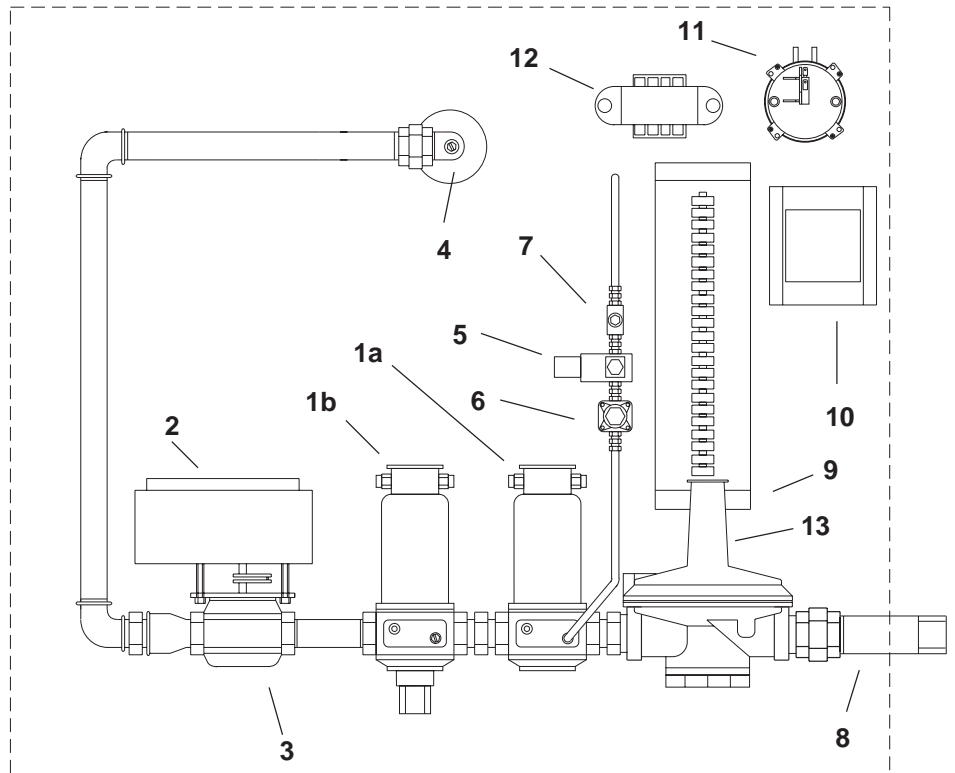

Fig 3a Block Valve Layout - DFU 100

- 1) 1st Main gas safety shut off valves.
- 2) 2nd Main gas safety shut off valves.
- 3) Main burner pressure adjustment screw.

Notes:-

- i) Electrical connection plugs not shown.

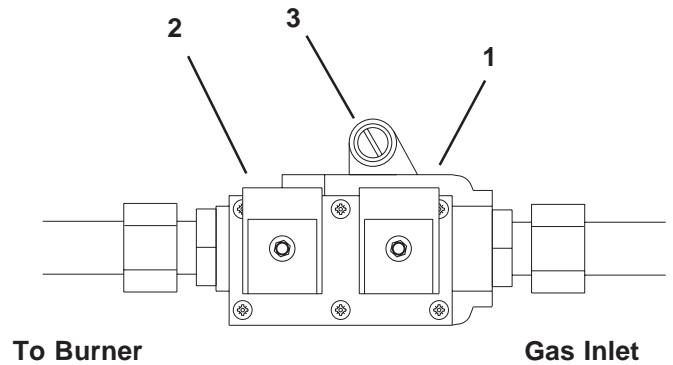
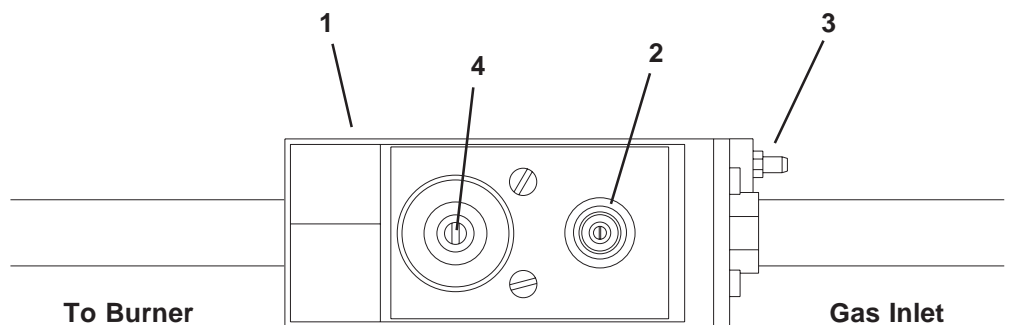

Fig 3b Block Valve Layout - DFU 250 - 1000

- 1) Main gas safety shut off valves.
- 2) Main burner pressure adjustment screw.
- 3) Inlet Pressure test point.
- 4) Flow rate and valve opening speed adjustments.

Notes:-

- i) Electrical connection plugs not shown.



to increase, anticlockwise to decrease.

3. Remove the temporary link from between terminals 2 and 4 in the duct temperature sensor and set TEMP 1 potentiometer to 20°C.

4. Adjust Pot 2 on the modulating gas valve to set the low fire burner pressure (*See Tables 3.1, 3.2*) Turn Pot 2 fully clockwise will give maximum low fire setting and then in stages turn anticlockwise until the required burner pressure is achieved. Allow time at each stage for the gas pressure to stabilize before further adjusting.

NOTE: If the desired low fire gas rate is overshoot then the potentiometer should be turned fully clockwise and step 4 repeated.

NOTE: Adjustment of the High fire potentiometer setting after setting of the Low fire potentiometer will alter the Low fire burner pressure and step 10 will need repeating.

5. Turn "OFF" the main electricity supply, remove pressure gauge and refit sealing screw in pressure test point.

6.4.3.3.2 Heaters supplied with a Room Thermostat

1. Ensure that the room thermostat is set to MAX (28°C).

2. Adjust Pot 1 on the modulating gas valve to obtain the required High Fire burner pressure - this is normally adjusted to fully clockwise. (*See Tables 3.1, 3.2*)

3. Ensure that the room thermostat is set to MIN (12°C).

4. Adjust Pot 2 on the modulating gas valve to set the low fire burner pressure (*See Tables 3.1, 3.2*) Turn Pot 2 fully clockwise will give maximum low fire setting and then in stages turn anticlockwise until the required burner pressure is achieved. Allow time at each stage for the gas pressure to stabilize before further adjusting.

NOTE: If the desired low fire gas rate is overshoot then the potentiometer should be turned fully clockwise and step 4 repeated.

5. Turn "OFF" the main electricity supply, remove pressure gauge and refit sealing screw in pressure test point.

6.4.3.4 Adjustment of Air Off Temperature Set Point - Heaters fitted with a Duct Thermostat

1. Remove the cover of the duct temperature sensor.

2. Two set point ranges are available viz TEMP 1 (65 - 95°C) and TEMP 2 (20 - 50°C). To select TEMP 2 range a link must be fitted between terminals 2 and 4. Conversely TEMP 1 range is selected when no link is fitted between terminals 2 and 4.

6.4.4 Final Soundness Test

1. After making final gas rate checks all joints on the gas controls assembly must be tested for soundness using leak detection fluid. Replace all covers.

6.4.5 Flame Safeguard

1. Whilst the burner is in operation close the gas service valve. The burner should go to lockout within 1 second.

6.9 Handing Over to the User

Hand the 'Users Instructions', the 'Installation, Commissioning and Servicing Instructions' and the 'Notes for Guidance on Application and Installation' to the user or purchaser for retention.

Adjust the automatic controls to those values required by the

User.

Finally, advise the user or purchaser that, for continued efficient and safe operation of the air heater, it is important that adequate servicing is carried out annually.

In the event that premises are not yet occupied turn OFF the gas and electricity supplies and leave instructional literature adjacent to the gas meter.

7 Servicing

Warning: Always switch OFF and disconnect electricity supply and close the gas service valve before carrying out any servicing work or replacement of failed components.

7.1 General

Full maintenance should be undertaken not less than once per year. After any servicing work has been completed or any component replaced the heater must be fully commissioned and tested for soundness as described in Section 6.

Note: It is necessary to remove gas supply from heater before removing adjacent upper panel.

7.2 Main Burner Assembly

1. Remove the screws securing the upper side panels of the heater and remove panels.

2. Release the union nut adjacent to the main burner and the union nut on the pilot gas pipe. Ease the pilot gas pipe out of the compression fitting. (DFU 250-1500 only).

3. Pull off the spark and rectification leads and after releasing the securing nut remove the earth lead.

4. Undo the two screws securing the burner mounting plates to the burner mounting frame and remove the burner assembly, complete with pilot assembly from the heater.

5. Undo the four screws and nuts securing the pilot assembly to the burner end plate and remove the assembly.

6. Using a stiff brush clean off any accumulated deposits from the burner ports, the rectification, earth and spark electrodes and the pilot burner.

7. Before reassembling complete Section 7.3.

8. Reassemble in reverse order. Note that the rectification lead goes onto the upper electrode, the spark lead onto the lower electrode.

7.3 Main Fans

1. Remove the screws from the appropriate lower panels that facilitate easy access to the main fan(s) and remove the panels.

2. Clean the fan blades with a stiff brush to remove any accumulated deposits.

3. Check that the impellor(s) are rigidly fixed to the drive shaft, that the assembly turns freely and is not out of balance.

4. Check that both the motor and fan pulleys are rigidly fixed to the motor and fan drive shaft respectively.

5. Inspect the fan belt(s) for any sign of wear or damage and change if necessary (see Section 8.).

8 Replacement of Faulty Components

Warning: Inadvertent substitution or replacement of similar components, particularly with plug-in bases could cause a hazard.

Note: The following sections assume that the centre front panel of the heater and the terminal strip cover has been removed.

8.1 Programming Control Unit

1. Undo the central securing screw of the programming control unit and remove the control box from its base by pulling forward (Fig 2a - 7, 2bc - 10).
2. Reassemble in reverse order.

8.2 Ignition Transformer

1. Complete 8.1 above.
2. Disconnect the ignition transformer wiring from the terminal strip. (See wiring diagram accompanying these instructions).
3. Remove the right hand, upper front side panel.
4. Remove the suppressor cap from the ignition electrode and remove the lead after undoing the securing screw within the cap.
5. Withdraw the H.T. lead through the control panel.
6. Remove the two screws in the base of the programming unit. (These secure both the base and the transformer to the mounting bracket).
7. The transformer can now be removed from beneath the programming unit base.
8. Reassemble in reverse order.

8.3 Block Valve Assembly DFU 250 - 1000.

1. Release the union on the gas service valve
2. Remove the electrical supply plug from the valve assembly.
3. Disconnect the pilot gas line inlet pipe at the union connection on the side of the block valve assembly. (DFU 250 - 1500 only).
4. Release the socket head cap screws securing the connection flanges to the main gas block valve and remove the block.
5. Remove pilot line compression fitting from the block valve body (DFU 250 - 1500 only) and refit in the replacement block valve. Fit new assembly in reverse order ensuring the valve assembly is correctly orientated for the direction of gas flow.

8.4 Main Gas Safety Shut Off Valves / Main Governor - DFU1500.

1. *DFU 100* - Remove the electrical supply plug from the valve assembly.

DFU 1500 - Remove the covers from the top of the valve coils and disconnect the electrical wiring. Release the cable glands and withdraw the cables.

2. *DFU 1500* - Disconnect the pilot gas line inlet pipe at the union connection on the side of the first safety shut off valve and disconnect the pilot line compression fitting after the pilot pressure test point tee. Remove the pilot gas line.
3. Release the union on the gas service valve and the union upstream of the main gas pressure test point. Remove the gas controls assembly.
4. Dismantle the gas controls assembly to access the required item.

DFU 1500 - If the first safety shut off valve is being replaced transfer the pilot compression fitting from the old valve to the new valve.

5. Fit new assembly in reverse order ensuring the valve assembly and or governor are correctly orientated for the direction of gas flow.

8.5 Pilot Safety Shut Off Valve Coil (DFU 250 - 1500)

Main Gas Safety Shut Off Valve (DFU 100)

1. Release the central securing screw in the electrical connection plug of the safety shut-off valve and remove the plug.

2. Release the valve coil securing nut and remove coil.
3. Refit new coil and reassemble in reverse order.

8.6 Pilot Safety Shut Off Valve and Pilot Gas Governor (Models DFU 250 - 1500 Only)

1. Release the central securing screw in the electrical connection plug of the pilot safety shut-off valve and remove the plug.
2. Release the two unions at each end of the pilot gas controls assembly and remove the assembly complete.
3. Dismantle the assembly as appropriate to gain access to the component requiring replacement, noting the orientation of the component.
4. Reassemble in reverse order.

8.7 Modulating Gas Valve Head

1. Release the four screws securing the cover and remove cover.
2. Disconnect electrical wiring from the terminal strip.
3. Undo the two M6 Nyloc nuts securing the head to the valve body and remove the head.
4. Fit new head, ensuring that the drive arm tag locates in the drive plate of the valve spindle, and reassemble in reverse order.

8.8 Main Fan Contactor

1. Remove the electrical wiring from the contactor terminals.
2. Remove the overload from the contactor.
3. Undo the two screws securing the contactor to the control panel.
4. Reassemble in reverse order. Refer to wiring diagram accompanying these instructions for electrical connections.

8.9 Main Fan Motor(s)

Note: Ensure that the fan direction of rotation corresponds with the direction of rotation arrow on the fan guard or case. If necessary reverse the direction of rotation by interchanging any two of the motor live leads at the terminal strip in the electrical panel.

1. Release the motor mounting plate securing screws and then release the belt tension by turning the tension adjustment screw clockwise. Remove the fan belts.
2. Disconnect the electrical connections from the motor and remove the motor. If required remove the motor pulley and fit same to the new motor.
3. Fit new motor and reassemble in reverse order.
4. Apply belt tension until a 12mm-15mm deflection is obtained when the centre of the belt is firmly depressed. *See Figure below.*

Fig 4 Belt Tension Adjustment

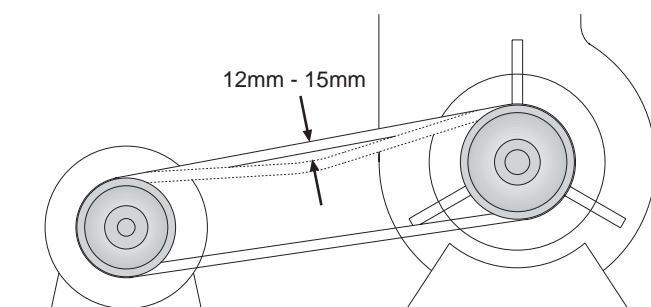

8.10 Main Air Fan(s)

Should it be necessary to remove one or more of the fans for cleaning proceed as follows.

1. Release the motor mounting plate securing screws and then remove the belt tension by turning the tension adjustment screw anticlockwise. Remove the fan belts.
2. Remove the screws securing the fan mounting feet to the heater framework and remove the fan. It may be necessary to re-orientate the fan within the fan compartment and also to release the fan shroud fixings in order to pass the fan through the heater frame. On units with twin or triple fan sets on a common fan shaft it will be necessary to first remove the fan shaft.
3. Fit new fans and reassemble in reverse order.
4. Retension fan belts *See section 8.8*

8.9 Pilot Assembly (DFU 250 - 1500 only)

1. Remove the right-hand upper front side panel.
2. Pull off the suppressor caps from the ignition and rectification electrodes.
3. Undo the compression fittings at each end of the pilot gas line and withdraw the pilot line.
4. Remove the four nuts and bolts which hold the pilot burner and earth wire to the main burner and remove.
5. Replace in reverse order ensuring that the earth wire is re-secured.

8.10 Air Pressure Switch

1. Pull off the electrical connections to the pressure switch (*Fig 2a - 8, Fig 2b/c - 11*).
2. Remove the tubes from the pressure switch noting their positions.
3. Unscrew the pressure switch retaining screws and remove.
4. Replace in reverse order.

8.11 High Limit Thermostat Honeywell L4064N

1. Release the single screw securing the fan and limit thermostat cover and remove cover by pulling forward.
2. Release wiring from clamp terminals by pushing a small screwdriver into the clamp release holes adjacent to the clamps.
3. Remove the 2 screws securing the thermostat to the heater panel and withdraw thermostat.
4. Reassemble new unit in reverse order referring to the heater wiring diagram accompanying these instructions to ensure correct wiring location.
5. Ensure that the limit settings are as follows:-
Limit 110°C

8.12 Duct Temperature Controller

1. Release the four cover securing and remove the cover.
2. Disconnect the wiring at the terminal block.
3. Remove the two screws holding the base to its fixing point and remove.
4. Reassemble in reverse order. Refer to wiring diagram accompanying these instructions for electrical connections.

Fig 5 Limit Thermostat Honeywell L4064N

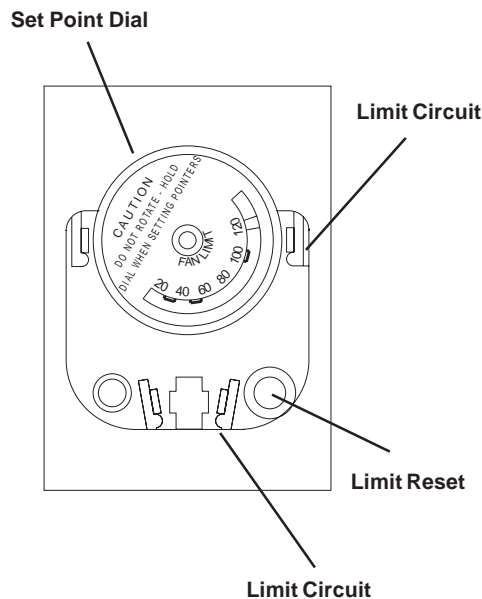

9. Connections to Powrmatic External Controls

9.1 Powrtrol

DFU Terminals	connect to	Powrtrol Terminals
1		1
2		2
3		3
4		4
5		5
6		6
		Earth

} Link

9.2 Eurotrol

DFU Terminals	connect to	Eurotrol Terminals
1		CTRL CCT
2		CTRL CCT
3		L
4		N
6		Earth
5		FAN CCT
		FAN CCT

} Link

10 Fault Finding

FAULTS	CAUSE	ACTION
DFU does not run- Lock out - Light OFF	Electrical	<ol style="list-style-type: none"> 1. Check electrical supply is ON. 2. Check time clock is in an ON mode. 3. Summer/Winter switch in OFF mode. 4. Room thermostat satisfied. 5. High limit thermostat tripped out. Check for reason, rectify and reset. 6. Faulty Programmer.
DFU runs but goes to lockout before pilot	Pressure Switch	<ol style="list-style-type: none"> 1. Blocked inlet - check for debris 2. Setting too low - Check setting against Technical Data Table. 3. Faulty Pressure switch - change.
	Electrical	1. Faulty Programmer.
	Electrical (No ignition)	<ol style="list-style-type: none"> 1. Check transformer connections to terminal strip refer to wiring diagram. 2. Check transformer H.T. cable connection to electrode. 3. Check condition of electrode for possible breakage or earthing. 4. Faulty transformer - change.
	No Gas	1. Check for air in line - purge gas line.
	(DFU 250 - 1500 Only)	<ol style="list-style-type: none"> 2. Check pilot solenoid connections to terminal strip -refer to wiring diagrams. 3. Faulty pilot solenoid - change. 4. Check pilot shut-off tap is ON.
DFU runs but goes to lock out before main flame	Electrical	<ol style="list-style-type: none"> 1. No flame detector signal - check connections - refer to wiring diagrams. 2. Check current value. This is checked by placing a d.c. micro-ammeter between terminals 13 and 14 after removing link the expected value for the current is between 10-15uA. but should not be less than 1.0uA. 3. Faulty Programmer. 4. Check main valve connections - refer to wiring diagram. 5. Faulty main valve - change.
	No Gas	1. Check main gas tap on outlet of assembly is ON.
DFU goes to main flame but remains on low flame	Electrical	<ol style="list-style-type: none"> 1. TW3 on low setting - adjust to higher required temperature. 2. Check modulating valve connections - refer to wiring diagrams. 3. Modulating cam slack - re-tighten. 4. Faulty cam motor - change unit. 5. Faulty Gastechnic STE2A - change.
DFU goes to main flame but does not modulate down	Electrical	<ol style="list-style-type: none"> 1. TW3 set too high - reset to a lower required temperature. 2. TW3 installed in wrong position - reposition out of excessively cold position. 3. Modulating cam slack - re-tighten. 4. Faulty Gastechnic STE2A - change.
DFU constantly goes to high limit		<ol style="list-style-type: none"> 1. Inlet blocked - clear debris from grille. 2. Thermostat set too low - readjust to correct setting - refer to Instructions. 3. Faulty thermostat - change 4. Check plug/socket connection and terminal connections - refer to wiring diagrams.

11. Short List of Parts

Refer to Powrmatic Ltd for the details of any parts not listed here.

ITEM	APPLICATION	PART NUMBER
Midco Burner 2"	100 (N Gas)	145600201
Midco Burner 6"	250 (N Gas)	145600289
Midco Burner 12"	500 (N Gas)	145600365
Midco Burner 18"	750 (N Gas)	145600445
Midco Burner 24"	1000 (N Gas)	145600521
Midco Burner 36"	1500 (N Gas)	145600603
Ignition Electrode - Midco	All	145601601
Rectification Electrode - Midco	All	145601623
Full Sequence Control Satronic MMI810 Mod 45	All	145601030
Johnson Controls GM-7742 - 3503 - ½"BSP	100	146571134
Johnson Controls GM-2040-9001 - ½"BSP	250,500	141379963
Johnson Controls GM-4040-9003 - 1½"BSP	750,1000	141379965
Johnson Controls GS 2011-5320 - 1½"BSP	1500	141300130
Johnson Controls GS 2011-5120 - 1½"BSP	1500	141300131
Johnson Controls SM474 - 0604 ¼"BSP	250 - 1500	145605400
Jeavons J48 - 2"BSP	1500	141330291
Jeavons 60DJ - ¼"BSP	250 - 1500	141330034
Pressure Switch EAC PS700 1.0mb	All	142403688
Thermostat - Limit Honeywell L4064N	All	143000303
Ignition Transformer - Satronic ZT812	All	145602400
Transformer - 230V/24V	All	141376033
Modulating Valve Head - DMA4	All	141379973
Modulating Valve Body - ½"BSP	100	141379972
Modulating Valve Body - ¾"BSP	250, 500	141379972/A
Modulating Valve Body - 1½"BSP	750 - 1500	141379972/B
Head / Duct Sensor - J C DCO - 001-65-95	All (if fitted)	145604602
Room Thermostat - J C TC8801-8001	All (if fitted)	145601027
Contactors - Danfoss CI 9	All	143000608
Overload - Danfoss TI 16 (0.6 - 0.92A)	100	143056103
Overload - Danfoss TI 16 (1.8 - 2.8A)	250	143000844
Overload - Danfoss TI 16 (2.7 - 4.2A)	500	143000706
Overload - Danfoss TI 16 (6.0 - 9.2A)	750	143000790
Overload - Danfoss TI 16 (8.0 - 12.0A)	1000, 1500	143000770
Y - Δ Starter - Danfoss SDI 12 047 L1280-38	1500	143070226



HEATING DIVISION

Winterhay Lane

Ilminster, Somerset TA19 9PQ

Tel: 01460 53535 Fax: 01460 52341

Every effort is made to ensure accuracy at time of going to press. However as part of our policy of continual product improvement, we reserve the right to alter specifications without prior notice.