



# **The EAG Range**

## **Commissioning And Servicing Instructions**

**WARNING: THIS APPLIANCE MUST BE EARTHED**

# CONTENTS

<i>Section</i>	<i>Title</i>	<i>Page</i>
<b>1.</b>	<b>Introduction</b>	<b>2</b>
<b>2.</b>	<b>Technical Data</b>	<b>3</b>
<b>3.</b>	<b>General Requirements</b>	<b>6</b>
<b>4.</b>	<b>Installation</b>	<b>7</b>
<b>5.</b>	<b>Air Distribution System</b>	<b>8</b>
<b>6.</b>	<b>Commissioning &amp; Testing</b>	<b>9</b>
<b>7.</b>	<b>Servicing</b>	<b>10</b>
<b>8.</b>	<b>Connections to Powrmatic External Controls</b>	<b>13</b>
<b>9.</b>	<b>Fault Finding</b>	<b>14</b>
<b>10.</b>	<b>Short List of Parts</b>	<b>15</b>

<i>Tables</i>	<i>Title</i>	<i>Page</i>
<b>1a.</b>	<b>Dimensions (S.I. Units)</b>	<b>4</b>
<b>1b.</b>	<b>Dimensions (Imperial Units)</b>	<b>4</b>
<b>2a.</b>	<b>Specifications (S.I. Units)</b>	<b>4</b>
<b>2b.</b>	<b>Specifications (Imperial Units)</b>	<b>5</b>
<b>3.1</b>	<b>Burner Pressures - Natural Gas Group H - G20</b>	<b>5</b>
<b>3.2</b>	<b>Burner Pressures - Propane - G31</b>	<b>5</b>
<b>4.</b>	<b>Electrical Loadings</b>	<b>6</b>

<i>Figure</i>	<i>Title</i>	<i>Page</i>
<b>1a.</b>	<b>Gas Control Schematic EA-G 100 - 300</b>	<b>10</b>
<b>1b.</b>	<b>Gas Control Schematic EA-G 400 - 2000</b>	<b>10</b>
<b>2a.</b>	<b>Gas Controls Layout EA-G 100, 150</b>	<b>11</b>
<b>2b.</b>	<b>Gas Controls Layout EA-G 200, 300</b>	<b>11</b>
<b>2c.</b>	<b>Gas Controls Layout EA-G 400 - 2000</b>	<b>11</b>
<b>3.</b>	<b>Belt Tension Adjustment</b>	<b>12</b>
<b>4.</b>	<b>Honeywell L4064N</b>	<b>13</b>
<b>5.</b>	<b>White Rodgers 5F464</b>	<b>13</b>

<i>Appendix</i>	<i>Title</i>	<i>Page</i>
<b>A</b>	<b>Calculation of Flue System Equivalent Resistance</b>	<b>16</b>

## 1. INTRODUCTION

The Powrmatic EA-G range of gas fired forced draught, closed flue, fanned circulation air heaters cover a heat output range of 29.3 kW (100000 Btu/h) to 586 kW (2000000 Btu/h) and are intended for heating commercial or industry premises and are for location outside the premises being heated without the need for a purpose built plant room. They are certified for use on Natural Gas, Group H - G20 and Propane - G31.

All models are available in UD, HD and RT variants. (U - Upright; H - Horizontal; D - Ducted; RT - Roof Top).

EA-G heaters have a centrifugal fan assembly fitted upstream of the combustion chamber / heat exchanger assembly to circulate the air being heated. The EA-G ###\*/D range, in having no fan fitted, is for ducted systems where the air moving fan is by others

Heaters are fitted as standard with fully automatic monoblock forced draught gas burners and monoblock gas control assemblies.

Options include High/Low or modulating burners, Deep V filters, proportional air dampers and weathered air inlet louvres.

“The Gas Safety (Installation & Use) Regulations (as amended) 1984”

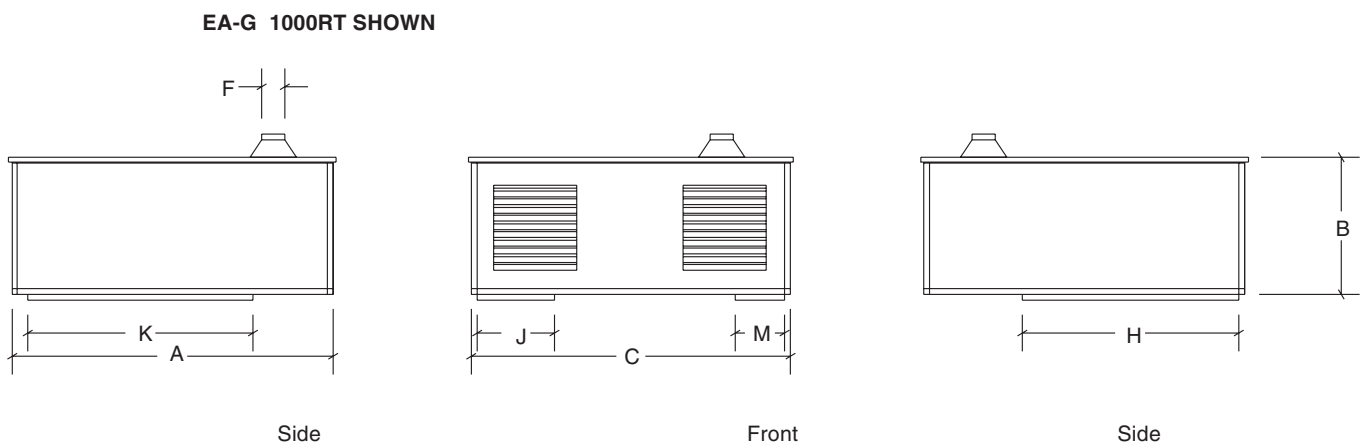
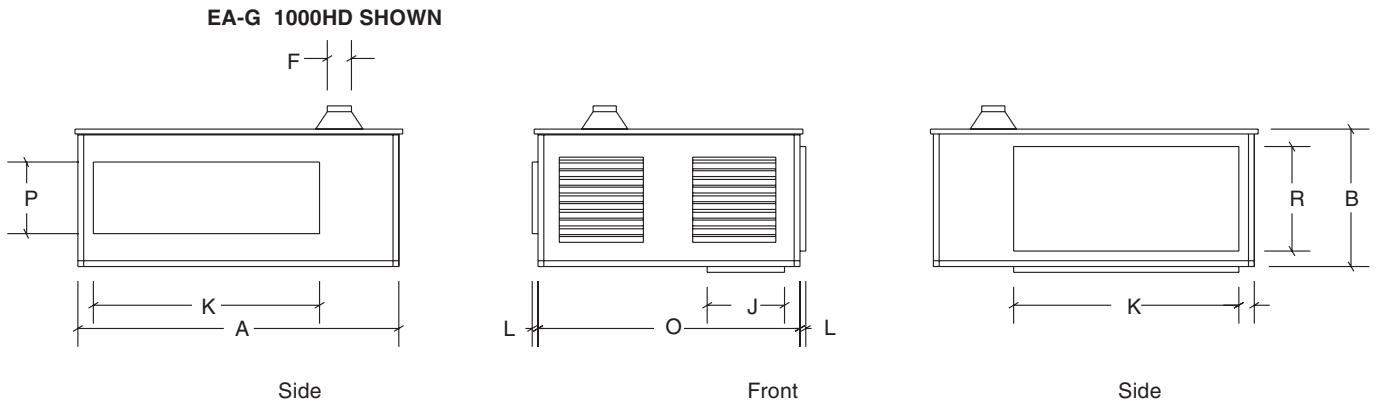
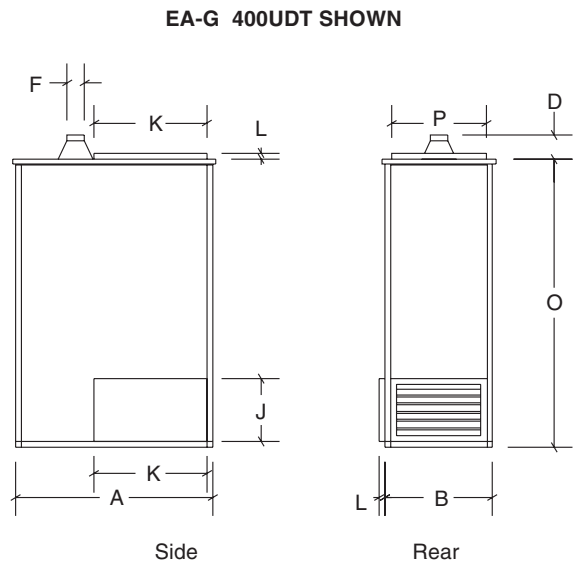
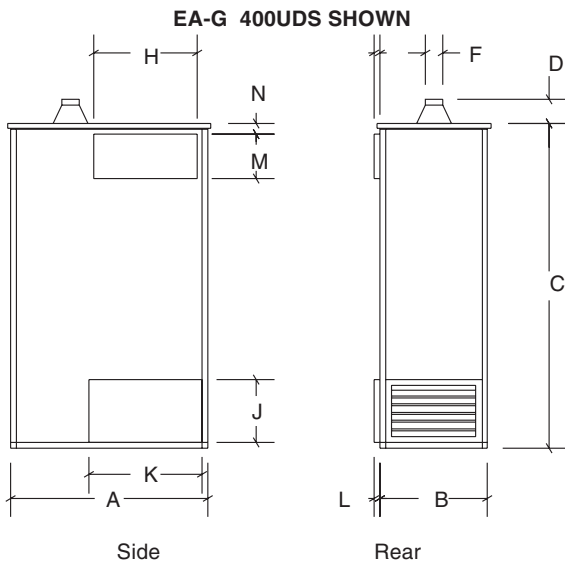
It is law that all gas appliances are installed by competent persons \* in accordance with the above regulations. Failure to install appliances correctly can lead to prosecution. It is in your own interests and that of safety to ensure that the law is complied with.

\* e.g. Corgi Registered

## 2 Technical Data

### 2.1 Dimensions

#### EA-G 400 - 2000 UF & UD Models



**Table 1a. Dimensions (S.I. Units)**

	A	B	C	D	F	H	J	K	L	M	N	O	P	R
EA-G 100	1340	603	1899	152	125	552	381	629	51	229	89	1645	502	502
EA-G 150	1416	629	2102	152	125	629	451	705		254		1822	527	527
EA-G 200										330				
EA-G 300	1466	730	2483	203	150	679	756	381		2356		808	808	
EA-G 400	1670	908	2762					883						959
EA-G 500	2280	1010	2381	152	175	1365	533	1441		419		1873	495	908
EA-G 600														
EA-G 700														
EA-G 800	2737	1162	2711	203	200	1848	1924	2330		660		2229	610	1067
EA-G 1000														
EA-G 1500	3194	1391	3626		300	2245				2788	660	1289		
EA-G 2000	Refer to Powrmatic													

**Table 1b. Dimensions (Imperial Units)**

	A	B	C	D	F	H	J	K	L	M	N	O	P	R
EA-G 100	53	24	75	6	5	21 $\frac{3}{4}$	15	24 $\frac{3}{4}$	2	9	3 $\frac{1}{2}$	64 $\frac{3}{4}$	19 $\frac{3}{4}$	19 $\frac{3}{4}$
EA-G 150	56	25	83			24 $\frac{3}{4}$	17 $\frac{3}{4}$	27 $\frac{3}{4}$		10		71 $\frac{3}{4}$	20 $\frac{3}{4}$	20 $\frac{3}{4}$
EA-G 200				26 $\frac{3}{4}$	21	29 $\frac{3}{4}$	13	81 $\frac{3}{4}$		24 $\frac{3}{4}$		24 $\frac{3}{4}$		
EA-G 300	58	29	98	8		6	34 $\frac{3}{4}$	37 $\frac{3}{4}$		15		96 $\frac{3}{4}$	31 $\frac{3}{4}$	31 $\frac{3}{4}$
EA-G 400	66	36	109	6	7	53 $\frac{3}{4}$	21	56 $\frac{3}{4}$		16 $\frac{1}{2}$		73 $\frac{3}{4}$	19 $\frac{1}{2}$	35 $\frac{3}{4}$
EA-G 500	90 $\frac{3}{4}$	40	94											
EA-G 600														
EA-G 700	107	46	107	8	8	72 $\frac{3}{4}$	25 $\frac{3}{4}$	75 $\frac{3}{4}$		26		88	24	42
EA-G 800														
EA-G 1000	126	54 $\frac{3}{4}$	143	8	12	88 $\frac{3}{4}$	91 $\frac{3}{4}$	91 $\frac{3}{4}$		26		110	26	50 $\frac{3}{4}$
EA-G 1500														
EA-G 2000	Refer to Powrmatic													

**Table 2a. Specifications (S.I. Units)**

MODEL	HIGH FIRE		LOW FIRE		AIR VOLUM	MAXIMUM DUCT RESISTANCE		FAN MOTOR		Gas Connection Size	WEIGHT kg
	INPUT (Nett)	OUTPUT	INPUT (Nett)	OUTPUT		Standard	L.H.P.	Standard	L.H.P.		
	kw		kw			pa		kw			
EA-G 100	33.3	29.3	N/A	N/A	0.5192	150	N/A	0.335	N/A	Rc $\frac{1}{2}$	152
EA-G 150	50.0	44.0	N/A	N/A	0.7788	290	N/A	0.55	N/A		177
EA-G 200	66.59	58.6	N/A	N/A	1.0383	200	N/A	0.56	N/A	Rc $\frac{3}{4}$	177
EA-G 300	100.0	88.0	N/A	N/A	1.5575	250	N/A	1.5	N/A		304
EA-G 400	133.2	117.2	N/A	N/A	2.0766	150	N/A	2.2	N/A		458
EA-G 500	166.5	146.5	N/A	N/A	2.9736	160	175	1.5	2.2		546
EA-G 600	199.8	175.8	N/A	N/A	3.4000	150	190	2.2	3.3	560	
EA-G 700	233.1	205.1	N/A	N/A	3.9647	120	200	2.2	3.3	Rc1 $\frac{1}{2}$	573
EA-G 800	266.5	234.5	N/A	N/A	4.5075	70	175	2.2	3.3		628
EA-G 1000	333.1	293.1	N/A	N/A	5.1919	220	250	4.0	5.5		845
EA-G 1500	4499.5	439.6	N/A	N/A	7.7880	200	250	2 x 5.5	2 x 7.5	1502	
EA-G 2000	Refer to Powrmatic										

**Table 2b. Specifications (Imperial Units)**

MODEL	HIGH FIRE		LOW FIRE		AIR VOLUM	MAXIMUM DUCT RESISTANCE		FAN MOTOR		Gas Connection Size	WEIGHT lb
	INPUT (Gross)	OUTPUT	INPUT (Gross)	OUTPUT		Standard	L.H.P.	Standard	L.H.P.		
	Btu/h		Btu/h			ft <sup>3</sup> /m	in wg		hp		
EA-G 100	126262	100000	N/A	N/A	1100	0.60	N/A	0.45	N/A	½"BSP	336
EA-G 150	189394	150000	N/A	N/A	1650	1.16	N/A	0.75	N/A		364
EA-G 200	252525	200000	N/A	N/A	2200	0.80	N/A	0.75	N/A	¾"BSP	392
EA-G 300	378788	300000	N/A	N/A	3300	1.00	N/A	2.0	N/A		672
EA-G 400	505050	400000	N/A	N/A	4400	0.60	N/A	3.0	N/A		1010
EA-G 500	631313	500000	N/A	N/A	6300	0.64	0.70	2.0	3.0		1204
EA-G 600	757576	600000	N/A	N/A	7200	0.60	0.76	3.0	4.5		1235
EA-G 700	883838	700000	N/A	N/A	8400	0.48	0.80	3.0	4.5	1½"BSP	1263
EA-G 800	1010101	800000	N/A	N/A	9550	0.28	0.70	3.0	4.5		1384
EA-G 1000	1262626	1000000	N/A	N/A	11000	0.88	1.00	5.5	7.5	1½"BSP	1863
EA-G 1500	1893939	1500000	N/A	N/A	165000	0.80	1.00	7.5	10.0		3311
EA-G 2000	Refer to Powrmatic										

**Table 3.1 Burner Pressures - Natural Gas - Group H - G20 - Net CV (H<sub>i</sub>) = 34.02MJ/m<sup>3</sup>**

MODEL	Powrmatic Burners			Riello Burners			Gas Rate	
	Type	Start Gas Pressure	Main Burner Pressure	Type	Start Gas Pressure	Main Burner Pressure	m <sup>3</sup> /h	ft <sup>3</sup> /h
		mbar	mbar		mbar	mbar		
EA-G 100	PCGS 2	N/A	4.8	GS 5	N/A	4.3	3.40	120.1
EA-G 150	PCGS 2	N/A	9.9	GS 10	N/A	4.2	5.12	180.8
EA-G 200	PCGS 3	N/A	12.2	GS 10	N/A	3.7	7.08	250.0
EA-G 300	PCGS 5	N/A	10.4	GS 10	N/A	5.2	10.89	384.6
EA-G 400	PCGS 5	1.5	8.8	GS 20	2.4	4.2	14.14	499.3
EA-G 500	PCGS 5	1.1	8.2	GS 20	2.4	5.4	17.07	602.8
EA-G 600	PCGS 8	2.5	9.7	GS 20	3.5	5.9	21.37	754.7
EA-G 700	PCGS 13	3	9.2	GAS 3	1.8	6.0	24.85	877.6
EA-G 800	PCGS 13	1.5	5.8	GAS 3	1.1	7.0	27.70	978.2
EA-G 1000	PCGS 13	2.4	9.0	GAS 3	3.3	9.5	35.10	1239.5
EA-G 1500	PCGS 25	1.2	9.0	GAS 5	0.75	7.0	52.86	1866.7
EA-G 2000	Refer to Powrmatic							

**Table 3.2 Burner Pressures - Propane - G31 - Net CV (H<sub>i</sub>) = 88.00MJ/m<sup>3</sup>**

MODEL	Powrmatic Burners			Riello Burners			Gas Rate	
	Type	Start Gas Pressure	Main Burner Pressure	Type	Start Gas Pressure	Main Burner Pressure	m <sup>3</sup> /h	ft <sup>3</sup> /h
		mbar	mbar		mbar	mbar		
EA-G 100	PCGS 2	N/A	6.9	GS 5	N/A	3.1	1.31	46.3
EA-G 150	PCGS 2	N/A	11.3	GS 10	N/A	6.4	1.98	69.9
EA-G 200	PCGS 3	N/A	20.0	GS 10	N/A	4.1	2.74	96.8
EA-G 300	PCGS 5	N/A	14.2	GS 10	N/A	8.3	4.21	148.7
EA-G 400	PCGS 5	3.5	23.4	GS 20	2.5	5.9	5.47	193.2
EA-G 500	PCGS 5	2.6	20.5	GS 20	2.5	6.8	6.60	233.1
EA-G 600	PCGS 8	1.9	22.8	GS 20	3.0	8.9	8.26	291.7
EA-G 700	PCGS 13	1.0	12.0	GAS 3	2.8	13.1	9.61	339.4
EA-G 800	PCGS 13	1.2	15.8	GAS 3	3.0	13.5	10.71	378.2
EA-G 1000	PCGS 13	2.0	22.5	GAS 3	4.3	21.0	13.57	479.2
EA-G 1500	PCGS 25	2.3	27.5	GAS 5	2.8	18.0	20.43	721.5
EA-G 2000	Refer to Powrmatic							

**Table 4 Electrical Loadings**

MODEL	ph	Standard					Larger Horsepower Motor				
		NOM. MOTOR R.P.M.	PLATE AMPS (A)	START AMPS (A)	RUN AMPS (A)	FUSE RATING (A)	NOM. MOTOR R.P.M.	PLATE AMPS (A)	START AMPS (A)	RUN AMPS (A)	FUSE RATING (A)
EA-G 100	1	1000	2.6	5.0	2.6	3	N/A				
EA-G 150		1500	5.0	8.5	6.1	7					
EA-G 200		1000	4.1	10.0	4.5	5					
EA-G 300			7.0	18.0	8.1	10					
EA-G 400			6.7	14.0	6.0	7					
EA-G 500	3	1500	3.55	16.0	3.8	5	5.2	14.0	4.8	5	
EA-G 600			5.2	14.0	5.2	7	7.4	25.0	6.8	7	
EA-G 700			5.2	25.0	5.7	7	7.4	26.0	8.8	10	
EA-G 800			5.2	27.0	5.2	7	7.4	25.0	7.8	10	
EA-G1000			8.7	30.0	9.7	10	12.0	37.0	12.5	15	
EA-G 1500			2 x 12.0	2 x 38.0	2 x 13.0	30	2 x 15.1	2 x 48.0	2 x 15.5	35	
EA-G 2000			Refer to Powmatic								

### 3. General Requirements

#### 3.1 Related Documents

The installation of the air heater(s) must be in accordance with the rules in force and the relevant requirements of the Gas Safety Regulations, Building Regulations and the I.E.E. Regulations for Electrical Installations.

It should be in accordance also with any relevant requirements of the local gas region, local authority and fire authority and the relevant recommendations of the following documents.

#### British Gas Plc Publications

IM/16: 1988 Guidance notes for the installation of gas pipework, boosters and compressors in Customer's premises (excluding domestic installation of 25mm and below).

#### British Standards Code of Practice

BS 5588 Fire precautions in the design and construction of buildings.

Part 2 : 1985 Code of Practice for Shops

Part 3 : 1983 Code of Practice for Office Buildings

BS 6230: 1991 Installation of Gas Fired Forced Convection Air Heaters for Commercial and Industrial Space Heating.

Those appliances having an input rating not exceeding 60kW viz. EA-G 100 and EA-G 150 must be installed in accordance with the relevant recommendations of the following documents. BS 5440 Flues and Air Supply for gas appliances of rated input not exceeding 60kW (1st and 2nd family gases).

Part 1 - Flues, Part 2 - Air Supply

For EA-G 100 and EA-G 150 units reference should also be made to BS 5864. Code of Practice for installation of gas-fired ducted-air heaters of rated input not exceeding 60kW.

For EA-G 100 and EA-G 150 units reference should also be made to BS 5864. Code of Practice for installation of gas-fired ducted-air heaters of rated input not exceeding 60kW.

#### 3.2 Location

The location chosen for the air heater must permit the provision

of a satisfactory flue system and an adequate air supply. The location must also provide adequate space for servicing and air circulation around the air heater.

The heater(s) must not be installed in conditions for which it is not specifically designed.

Where the location of the air heater is such that it might suffer external mechanical damage e.g. fork lift trucks, it must be suitably protected.

EA-G units are designed to operate in a maximum ambient temperature of 30 °C.

### 3.3 Gas Supply

#### 3.3.1 Service Pipes

The local gas undertaking should be consulted at the installation planning stage in order to establish the availability of an adequate supply of gas. An existing service pipe must not be used without prior consultation with the local gas undertaking.

#### 3.3.2 Meters

A gas meter is connected to the service pipe by the local gas undertaking or a local gas undertaking contractor. An existing meter should be checked, preferably by the gas undertaking, to ensure that the meter is adequate to deal with the total rate of gas supply required.

#### 3.3.3. Installation Pipes

Installation pipes should be fitted in accordance with IM/16:1988. Pipework from the meter to the air heater must be of adequate size. Do not use pipes of a smaller size than the inlet gas connection of the heater. The complete installation must be tested for soundness as described in the above Code. The complete installation must be tested for soundness as described in BS 6230.

#### 3.3.4. Boosted Supplies

Where it is necessary to employ a gas pressure booster the controls must include a low pressure cut off switch at the booster inlet. The local gas undertaking must be consulted before a gas pressure booster is fitted.

### 3.4 Flue System

Detailed recommendations for fluing are given in BS 5440, Part 1 (Flues) and IM/11.

The air heater must be connected to a closed flue system. The cross sectional area of the flue serving the appliance must be not less than the area of the flue outlet to the air heater.

Materials used for the flue system should be mechanically robust, resistant to internal and external corrosion, noncombustible and durable under the conditions to which they are likely to be subjected.

Prevention of condensation within the flue should be an important factor in the design of the flue system. In order to minimise condensation the use of double walled flue pipe or insulation is recommended. If double walled flue pipe is used it should be of an acceptable type.

Where condensation in the flue is unavoidable provision should be made for condensation to flow freely to a point at which it can be released, preferably into a gully. The condensation pipe from the flue to the disposal point should be of non-corrodible material of not less than 22mm (1/2") size.

Facilities should be made for disconnecting the flue pipe(s) from the air heater(s) for inspection and servicing purposes. Bends with removable covers should be fitted for inspection and cleaning purposes where considered appropriate.

The flue should terminate in a freely exposed position and must be so situated as to prevent the products of combustion entering any opening in a building in such concentration as to be prejudicial to health or a nuisance.

It is recommended that consideration be given to the fitting of a terminal at the flue outlet, however, where the heater flue is less than 200mm (8") in diameter an approved terminal must be fitted.

### 3.5 Air Distribution System

The following notes are of particular importance.

In buildings having a low heat loss where single units are required to cover a large floor area and in buildings with high roof or ceiling heights Calecon thermal economiser units should be fitted to ensure even heat distribution and minimise stratification respectively. For ducted units all delivery and return air ducts, including air filters, jointing and any insulation or lining must be constructed entirely of materials which will not contribute to a fire, are of adequate strength and dimensionally stable for the maximum internal and external temperatures to which they are to be exposed during commissioning and normal operation. In the selection of materials account must be taken of the working environment and the air temperatures which will result when the overheat limit thermostat is being commissioned. Where inter-joint spaces are used as duct routes they should be suitably lined with a fire-resisting material.

A full and unobstructed return air path must be provided to the air heaters that are installed with recirculated air systems.

The openings in the structure of the building through which the ducting passes must be fire stopped.

Care must be taken to ensure that return-air intakes are kept clear of sources of smells and fumes, and in special circumstances where there is any possibility of pollution of the air by dust, shavings etc., precautions must be taken by carefully positioning return air intakes and by the provision of screens to prevent contamination.

In addition, where there is a risk of combustible material being

placed close to the warm air outlets, suitable barrier rails should be provided to prevent any combustible material being within 900mm (3ft) of the outlets.

### 3.6 Electrical Supply

Wiring external to the air heater must be installed in accordance with the I.E.E. Regulations for Electrical Installations and any local regulations which apply. Wiring should be completed in flexible conduit.

Heaters EA-G 100 - EA-G 300 are supplied by 230V - 1ph, 50Hz., the remaining heaters by 400V - 3ph, 50Hz. The method of connection to the main electricity supply must facilitate the complete electrical isolation of the air heater(s) and the supply should serve only the air heater(s).

The isolator must have a contact separation of at least 3mm in all poles. The method of connection should be provided adjacent to the air heater(s) in a readily accessible position.

See the accompanying wiring diagram for the heater electrical connections.

## 4. Installation of Air Heater(s)

### 4.1 General

**Before installation, check that the local distribution conditions, nature of gas and pressure, and adjustment of the appliance are compatible.**

The air heater must be installed in accordance with the rules in force and the relevant requirements of any fire regulations or insurance company's requirements appertaining to the area in which the heater is located, particularly where special risks are involved such as areas where petrol vehicles are housed, where cellulose spraying is carried out, in wood working departments etc.

Whichever method of mounting the air heater is used the following minimum clearances for installation and servicing must be observed.

To the front	The depth of the heater
To the rear	1.0m (3.3ft)
To at least one side	1.0m (3.3ft)
Above the heater	1.00m (3.3ft)

Heaters must be installed on a purpose designed plinth or frame work to suit the site conditions. In addition the plinth or framework must ensure that the lowest point of any air entry point into the heater is at least 500mm above the ground or roof level.

Any combustible material adjacent to the air heater and the flue system must be so placed or shielded as to ensure that its temperature does not exceed 65 °C (150 °F).

#### **IMPORTANT:**

1. No air heater shall be installed where there is a foreseeable risk of flammable particles, gases vapours or corrosion inducing gases or vapours being drawn into either the heated air stream or the air for combustion. In such cases installation may only proceed if the air to be heated and the air for combustion are ducted to the heater from an uncontaminated source preferably outside the building. In certain situations where only airborne particles are present it may suffice to fit filters on the air inlet ducts of the heater. Advice in these instances may be obtained from Powrmatic Ltd.

### 4.2 Fitting the Air Heater



Floor mounted heaters must be installed on a level noncombustible surface.

Roof Top heaters must be installed either on specifically designed cradles or platforms that are capable of adequately supporting the weight of the unit (*See Tables 2a and 2b, Page 5*) and allowance must be made for any ancillary equipment. Before installing the heater any existing trusses, walls, brackets etc., must be inspected to ensure they are suitable. All supports should be protected against the effects of rust or corrosion. The means of mounting should also provide for service access wherever possible.

If noise levels are of particular importance the heater should be insulated from the structure of the building by installing it on suitable anti-vibration mountings. In all such cases and, in addition, when the heater is suspended it is essential that all gas, duct, electrical and flue connections to the heater are made with flexible connections to maintain continuity of connection. In the case of the flue connection single wall stainless steel flue is deemed to flex sufficiently to meet the requirements.

### 4.3 Connection of Air Heater(s) to Flue System

In the case of all heaters except Roof Top types a single wall Tee piece is supplied with each heater and must be fitted to the flue outlet socket on the heater. The flue system then connects directly on to the tee. *For flue sizes refer to Tables 1a and 1b Page 4*. All units must be fitted with a flue having a minimum height, from the heater to the flue terminal, of 2m (6.5ft). Horizontal runs of flue are not permitted. If necessary a single offset using two 45° bends can be included to avoid obstructions. The maximum equivalent resistance of the flue system must not exceed 20pa. Details of how to calculate the resistance of the flue to be installed are given in Appendix A.

### 4.4 Condensate Drainage

The design of the flue system should minimise the formation of condensation, however when this is envisaged to be a problem provision should be made for condensation to flow to a joint where it can be drained, preferably into a gully.

### 4.5 Gas Connection

A servicing valve and downstream union must be fitted at the inlet to the air heater gas controls assembly to facilitate servicing. The gas supply to the air heater must be completed in solid pipework that is suitably protected from the elements and be adequately supported.

#### WARNING

When completing the final gas connection to the heater do not place undue strain on the gas pipework of the heater.

### 4.6 Electrical Connections

All units are fully pre-wired and only require final connections for the incoming mains supply and completion of the control circuit (230V) via a room thermostat, time clock etc. The electrical supply must be run to a point adjacent to the heater and be suitably terminated to provide an isolation point that will prevent remote activation of the unit during servicing. The heater electrical panel is located within the burner compartment and cable entry points are provided in the adjacent heater framework. Reference must be made to Table 4 (*Page 6*) to ascertain the electrical loading of the air heater(s) being installed

so that cables of adequate cross-sectional area to safely carry that load are used for the electrical installation. The length of the conductors between the cord anchorage and the terminals must be such that the current carrying conductors become taut before the earth conductor if the cable or cord slips out of the cord anchorage. All external controls must be of an approved type. *See the wiring diagram accompanying these instructions.*

When installing EA-G 'D' models they must be electrically interlocked to the air movement system so that this is started in the same manner as the air heater fan would be. A connection from heater terminal No 9 must be made to one side of the fan motor contactor coil, the other side of the coil being connected to Neutral. Under no circumstances must the fan motor electrical supply be taken direct from the internal wiring of the heater.

## 5. Air Distribution System

### 5.1 General

EA-G \*D models are designed for use with duct work to more precisely define the point of air delivery, and/or provide ducted return air or ducted fresh air inlet. All ducting must be independently supported of the air heater. Joints and seams of supply ducts and fittings must be securely fastened and made airtight.

### 5.2 Noise Reduction

If deemed necessary consideration should be given to mounting the heater on resilient pads, or equivalent, to minimise transfer of noise and vibration to the structure of the building.

It is recommended that ducting should be connected to the heater spigots via an airtight flexible coupling of noncombustible material. Before fitting coupling it must be ensured that a maximum clearance of 13mm (1/2") will be maintained between the ends of the ducting and the heater spigots.

If required sound attenuators may be fitted in inlet and outlet ducts to reduce airborne fan noise. Materials used in outlet sound attenuators must be capable of withstanding 100 °C air temperature without any deterioration.

### 5.3 Room Thermostat Siting

The room thermostat should be fitted at a point which will be generally representative of the heated area as far as temperature is concerned. Draughty areas, areas subjected to direct heat e.g. from the sun, and areas where the air movement is relatively stagnant e.g. in recesses, are all positions to be avoided for siting the thermostat.

The thermostat should be mounted about 1.5m (5ft) from the floor.

Any room thermostat, frost thermostat, time clock etc. must be suitable for switching 230V, 5A and must be of the 'snap action' type to minimise contact bounce.

*For electrical connections of external controls see the accompanying wiring diagram.*

## 6. Commissioning & Testing

## 6.1 Electrical Installation

Checks to ensure electrical safety must be carried out by a competent person.

## 6.2 Gas Installation

The whole of the gas installation, including the meter, should be inspected and tested for soundness and purged in accordance with the recommendations of IM/16:1988.

## 6.3 Air Distribution System

The system should be checked to ensure that the installation work has been carried out in accordance with the design requirements.

Particular attention should be given to the correct arrangement of delivery ducts and registers, return air ducts and grills and general adequacy of return air paths.

For EA-G \*D heaters ensure that the total duct system resistance does not exceed the available air pressure of the equipment supplied refer to *Table 2a & 2b (Page5)*. If the duct system resistance is less than the available air pressure of the equipment supplied additional resistance must be introduced e.g. by adjustment of duct outlet nozzles and balancing of the duct system.

## 6.4 Lighting the Air Heater

### 6.4.1 Gas Controls Assembly - Soundness Check

1. Ensure the gas service valve at the inlet to the gas controls assembly is shut.
2. To prove soundness of the first main safety shut-off valve and first start gas safety shut-off valve:-
  - a) Connect pressure gauge to the inlet pressure test point on the main valve block or inlet pipework.
  - b) Open gas service valve and allow pressure to stabilise before shutting it again. The valves are sound if no pressure drop is observed. If a pressure drop is observed do not proceed until the fault has been rectified. Remove pressure gauge and refit sealing screw in pressure test point.

### 6.4.2 Sequence Check

1. Ensure that the gas service valve is **closed** and that the main electrical supply to the heater is switched off.
2. Check that all external controls are either "ON" or at "MAX"
3. Turn "ON" the main electrical supply and check that the following sequence of events occurs.
  - i) Burner fan runs.
  - ii) Ignition spark is heard.
  - iii) Start gas valves open (Main gas valves on CA G100 - 300.
  - iv) Burner goes to lockout as there is no gas supply.
4. Switch off main electricity supply.

### 6.4.3 Final Adjustment

#### 6.4.3.1 EA-G 100 - 300

**IMPORTANT:** The maximum flow and start flow adjustments provided on the GM main gas block valve assembly (*Fig 2b - 4*) are not used and must not be adjusted.

1. Remove the sealing screw from the pressure test point located on the side of the gas inlet to the burner head and attach a pressure gauge. Remove the sample point cover plug from the outlet flue length and insert a CO<sub>2</sub> measuring instrument.

2. Turn "ON" the main electricity supply and check that the following sequence of events occur.

- i) Burner fan runs.
  - ii) Ignition spark is heard.
  - iii) Main gas valves open and Main gas flame is established.
3. Check that the main burner gas pressure agrees with that in Tables 3.1 or 3.2. If necessary adjust the main burner gas pressure (*Fig 2a - 3 or Fig 2b - 2*).
  4. Measure the CO<sub>2</sub> content of the flue gases. If necessary adjust the combustion air damper of the burner (*Refer to the Burner Supplement*) to obtain a reading of 9.0 - 9.5%
  5. Turn "OFF" the main electricity supply, remove pressure gauge and refit sealing screw in pressure test point and flue sample point cover plug.

#### 6.4.3.2 EA-G 400 - 2000

**IMPORTANT:** The maximum flow and start flow adjustments provided on the GM main gas block valve assembly (*Fig 2c - 4*) are not used and must not be adjusted.

1. Remove the sealing screw from the pressure test point located on the side of the gas inlet to the burner head and attach a pressure gauge. Remove the sample point cover plug from the outlet flue length and insert a CO<sub>2</sub> measuring instrument.
2. Remove the electrical cover from the downstream main gas valve and pull apart the inline connector.
3. Turn "ON" the main electricity supply and check that the following sequence of events occur.
  - i) Burner fan runs.
  - ii) Ignition spark is heard.
  - iii) Start gas valves open.
  - iv) Start gas flame is established.
4. Check that the start gas pressure agrees with that in Tables 3.1 or 3.2. If necessary adjust the start gas pressure (*Fig 2c - 5*).
4. Turn "OFF" the main electricity supply.
5. Reconnect the inline connector and refit valve electrical cover.
6. Turn "ON" the main electrical supply and the burner will run through its sequence until main flame is established. Check that the main burner gas pressure agrees with that in Tables 3.1 or 3.2. If necessary adjust the main burner gas pressure (*Fig 2c - 3*).
7. Measure the CO<sub>2</sub> content of the flue gases. If necessary adjust the combustion air damper of the burner (*Refer to the Burner Supplement*) to obtain a reading of 9.0 - 9.5%.
8. Remove pressure gauge, refit sealing screw in pressure test point and flue sample point cover plug.

### 6.4.4 Final Soundness Test

1. After making final gas rate checks all joints on the gas controls assembly must be tested for soundness using leak detection fluid.

### 6.4.5 Flame Safeguard

1. Whilst the burner is in operation close the gas service valve. The burner should go to lockout within 1 second.

## 6.5 Handing over the Air Heater

Hand the Users Instructions to the user or purchaser for retention and instruct in the efficient and safe operation of the air heater and associated controls.

Adjust the automatic controls to those values required by the User.

Finally, advise the user or purchaser that, for continued efficient

and safe operation of the air heater, it is important that servicing is carried out annually.

In the event that the premises are not yet occupied turn off the gas and electricity supplies and leave instructional literature adjacent to gas meter.

## 7. Servicing

**WARNING:** Always switch off and disconnect electricity supply and close the gas service valve before carrying out any servicing work or replacement of failed components.

### 7.1 General

Full maintenance should be undertaken not less than once per year. After any servicing work has been complete or any component replaced the air heater(s) must be fully commissioned and tested for soundness as described in Section 6.

### 7.2 Burner Maintenance

1. Access to the burner is via the burner compartment access door. Refer to the Burner Supplement supplied with the heater.

**Note:** Any references therein to the gas controls assembly should be ignored.

### 7.3 Heat Exchanger Cleaning

1. Disconnect the gas supply at the inlet to the gas controls assembly.
2. Disconnect the electrical connections from the heater electrical panel to the burner at the burner.
3. Remove the nuts securing the burner to the heat exchanger and remove the burner.
4. **Rear Flued Heaters only**
  - a. Remove the fan/limit thermostat as described in 7.5.4
  - b. Remove the upper front panel of the heater to expose the heat exchanger clean out panel.
- Front Flued Heaters only**
  - a. Remove the upper rear panel of the heater to expose the heat exchanger clean out panel.
5. Remove the nuts securing the panel and remove the panel.
6. Remove the nuts securing the heat exchanger baffles retention strip and remove strip. Withdraw the baffles.
7. Brush through heat exchanger tubes and remove loose material using a vacuum cleaner. Remove any loose material from the base of the combustion chamber, working through the burner port.
8. Reassemble all components in reverse order. Inspect all gaskets and replace if necessary.

## Gas Controls Schematics

Fig 1a EA-G 100 - 300

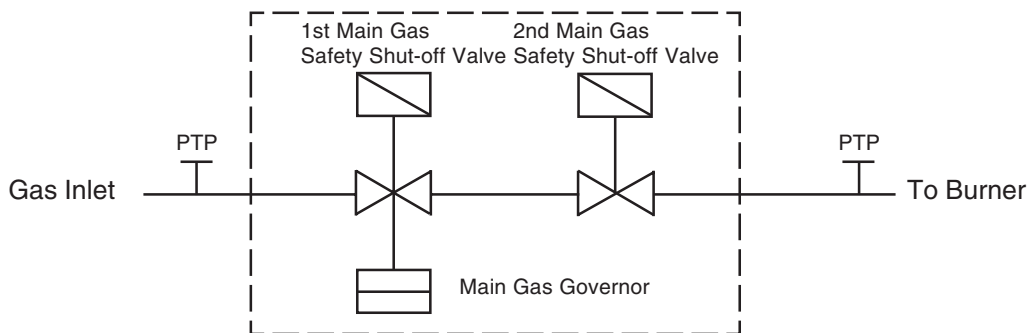
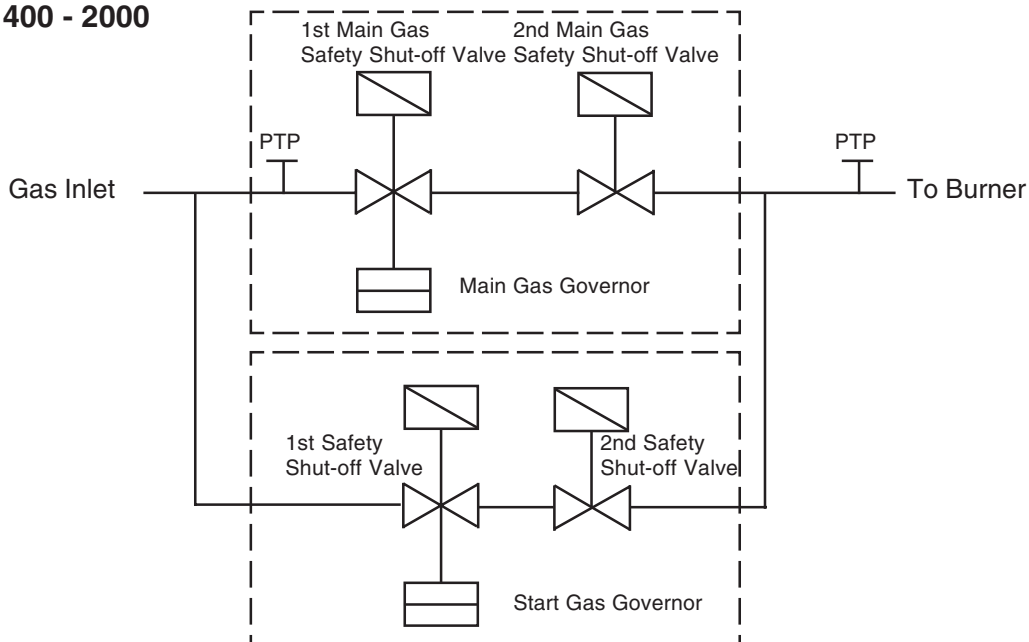


Fig 1b EA-G 400 - 2000

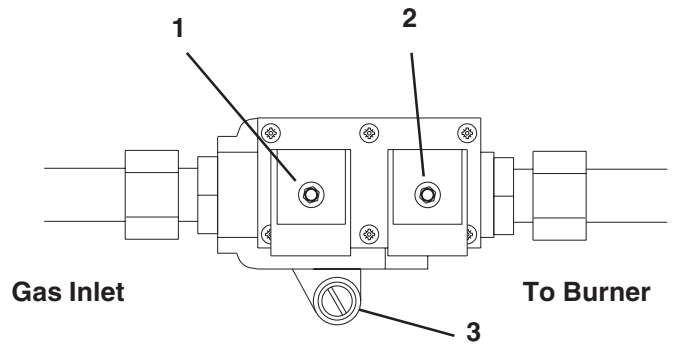


**Fig 2a Gas Controls Layout EA-G 100, 150**

- 1) 1st Main gas safety shut off valves.
- 2) 2nd Main gas safety shut off valves.
- 3) Main burner pressure adjustment screw.

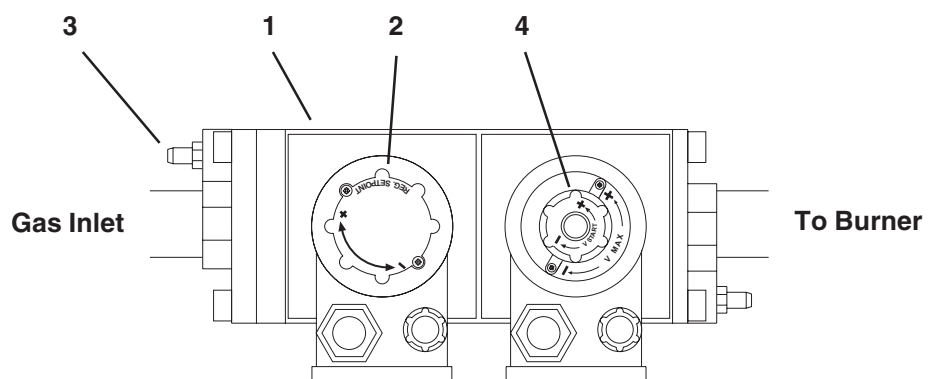
Notes:-

- i) Electrical connection plugs not shown.

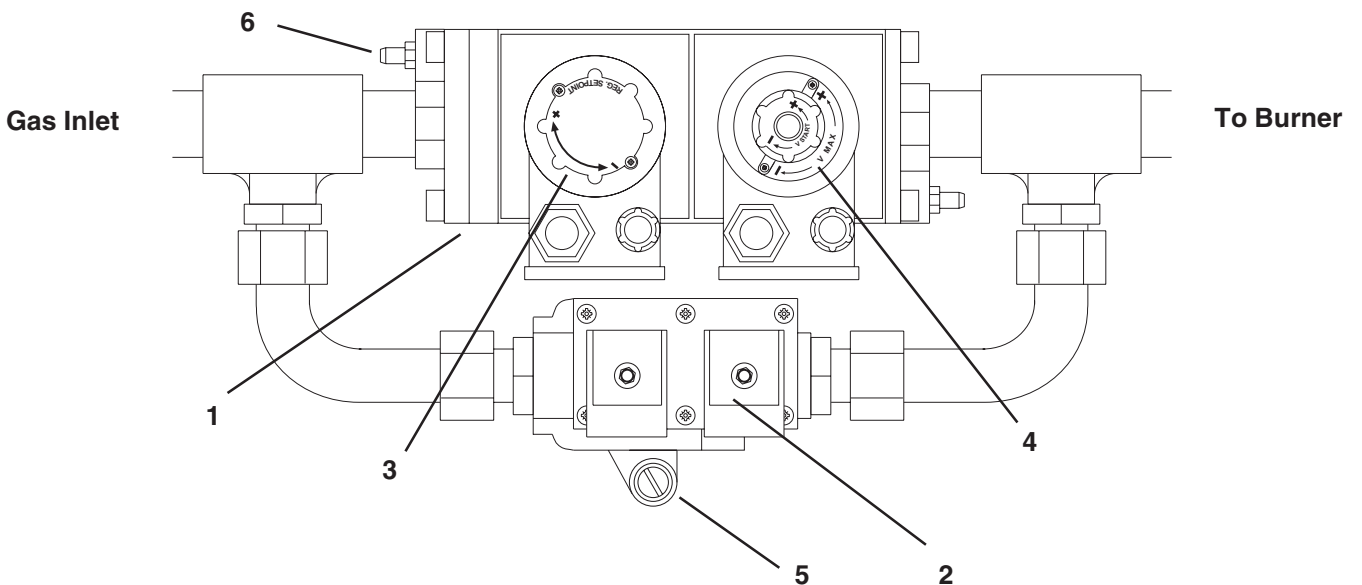


**Fig 2b Gas Controls Layout EA-G 200, 300**

- 1) Main gas safety shut off valves.
- 2) Main burner pressure adjustment screw.
- 3) Inlet Pressure test point.
- 4) Flow rate and valve opening speed adjustments.



**Fig 2c Gas Controls Layout EA G 400 - 2000**



- 1) Main gas safety shut off valves.
- 2) Start gas safety shut off valves.
- 3) Main burner pressure adjustment screw.
- 4) Flow rate and valve opening speed adjustments.
- 5) Start gas pressure adjustment screw.
- 6) Pressure test point.

## 7.3 Fan Assembly

1. Remove the outer panels of the heater to gain access to the fan section.
2. Inspect the fan blades to see that they are not damaged and that there is no excessive build up of deposits that could give rise to an imbalance. If necessary clean the fan blades using a stiff brush and vacuum cleaner.

## 7.4 Replacement of Faulty Components

### 7.4.1. Burner Components

1. Refer to the burner supplement supplied with the heater.

### 7.4.2 Gas Controls Assembly

#### 7.4.2.1 EA-G 100, 150

##### 7.4.2.1.1 Gas Valve Coil.

1. To fit a new valve operating coil remove the electrical supply plug, release the securing nut on top of the valve stem and remove the nut and washer. Lift off the faulty coil and fit the new coil in reverse order.

##### 7.4.2.1.2 Block Valve Assembly.

1. Remove the electrical supply plug.
2. Release the unions on the connections at each end of the assembly and remove complete assembly. Fit new assembly in reverse order ensuring the valve assembly is correctly orientated for the direction of gas flow.

#### 7.4.2.2 EA-G 200, 300

##### 7.4.2.2.1 Block Valve Assembly.

1. Release the union on the gas service valve.
2. Remove the electrical connections to the valve assembly.
3. Release the socket head cap screws securing the connection flanges to the main gas block valve and remove the block. Fit new assembly in reverse order ensuring the valve assembly is correctly orientated for the direction of gas flow.

#### 7.4.2.3 EA-G 400 - 2000

1. Release the union on the gas service valve
2. Remove the electrical connections to the valve assembly.
3. Release the unions on the connections at each end of the start gas block valve assembly and remove complete assembly.
4. Release the socket head cap screws securing the connection flanges to the main gas block valve and remove the block. Fit new assembly in reverse order ensuring the valve assembly is correctly orientated for the direction of gas flow.

### 7.4.3 Main Fan Motor(s)

#### 7.4.4.1. EA G100 - EA G400

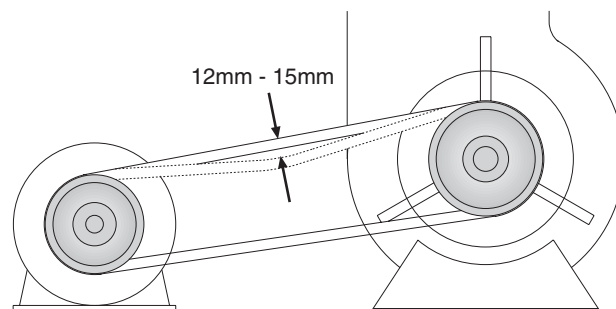
**Note:** These heaters are fitted with direct drive fan units that have an integral fan motor. The fan and motor must be exchanged as complete unit.

#### 7.4.4.2 EA-G 500 - 2000

1. Release the motor mounting plate securing screws and then release the belt tension by turning the tension adjustment screw clockwise. Remove the fan belts.
2. Disconnect the electrical connections from the motor and remove the motor. If required remove the motor pulley and fit same to the new motor.
3. Fit new motor and reassemble in reverse order.
4. Apply belt tension until a 12mm-15mm deflection is obtained

when the centre of the belt is firmly depressed. See Figure that follows.

## Fig 3 Belt Tension Adjustment



### 7.4.4 Main Air Fan(s)

**Note:** On 3ph heaters ensure that the fan direction of rotation corresponds with the direction of rotation arrow on the fan guard or case. If necessary reverse the direction of rotation by interchanging any two of the motor live leads at the terminal strip in the electrical panel.

Should it be necessary to remove one or more of the fans for cleaning proceed as follows.

#### 7.4.4.1. EA G100 - EA G400

**Note:** These heaters are fitted with direct drive fan units.

1. Disconnect the fan motor electrical leads from the terminal strip (Refer to Wiring Diagram supplied with the heater)
2. Remove the two screws, one on each side of the fan mounting flange, then secure the fan to the fan shroud.
3. Withdraw the fan from the slide rails.
4. Reassemble in reverse order.

#### 7.4.4.2. EA-G 500 - EA-G 2000

**Note:** These units are fitted with belt driven main air fans.

1. Release the motor mounting plate securing screws and then remove the belt tension by turning the tension adjustment screw anticlockwise. Remove the fan belts.
2. Remove the screws securing the fan mounting feet to the heater framework and remove the fan. It may be necessary to re-orientate the fan within the fan compartment and also to release the fan shroud fixings in order to pass the fan through the heater frame. On units with twin or triple fan sets on a common fan shaft it will be necessary to first remove the fan shaft.
3. Fit new fans and reassemble in reverse order.
4. Retension fan belts See section 7.4.4.2

### 7.4.5 Fan and Limit Thermostats

#### 7.4.5.1 EA-G 100 - EA-G 400 - Fan / Limit Thermostat - Honeywell L4064N

1. Release the single screw securing the fan and limit thermostat cover and remove cover by pulling forward.
2. Release wiring from clamp terminals by pushing a small screwdriver into the clamp release holes adjacent to the clamps.
3. Remove the 2 screws securing the thermostat to the heater panel and withdraw thermostat.
4. Reassemble new unit in reverse order referring to the heater wiring diagram to ensure correct wiring location.

**Important:** As supplied by the Manufacturer this fan/limit thermostat is fitted with a brass jumper between the bottom fan terminal and the bottom limit terminal (situated in the slot between the two terminals). This MUST be removed, by using a pair of thin nose pliers, before the replacement thermostat is

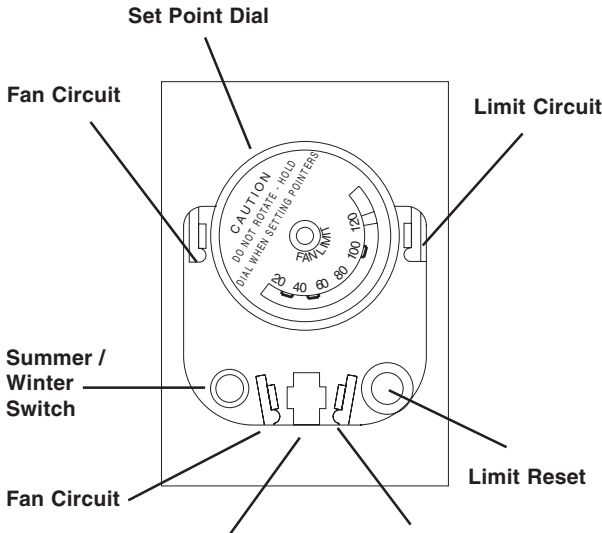


installed.

5. Ensure that the fan and limit settings are as follows:-

Fan ON	50°C	
Fan OFF	30°C	
Limit	EA-G 100	90°C
	EA-G 150 - 300	110°C
	EA-G 400	100°C

**Fig 4 Honeywell L4064N**



**7.4.5.2 EA-G 500 - EA-G 2000 - Fan / Limit Thermostat - White Rodgers 5F464**

1. Release the single screw securing the fan and limit thermostat cover and remove cover by pulling forward.
2. Release wiring from screw terminals.
3. Remove the head base or a top side panel from the heater to gain access to the heat exchanger and release the thermostat sensing phial from its holder on top of the heat exchanger.
3. Remove the 2 screws securing the thermostat to the heater panel and withdraw thermostat and phial.
4. Reassemble new unit in reverse order referring to the heater wiring diagram to ensure correct wiring location.
5. Ensure that the fan and limit settings are as follows:-
 

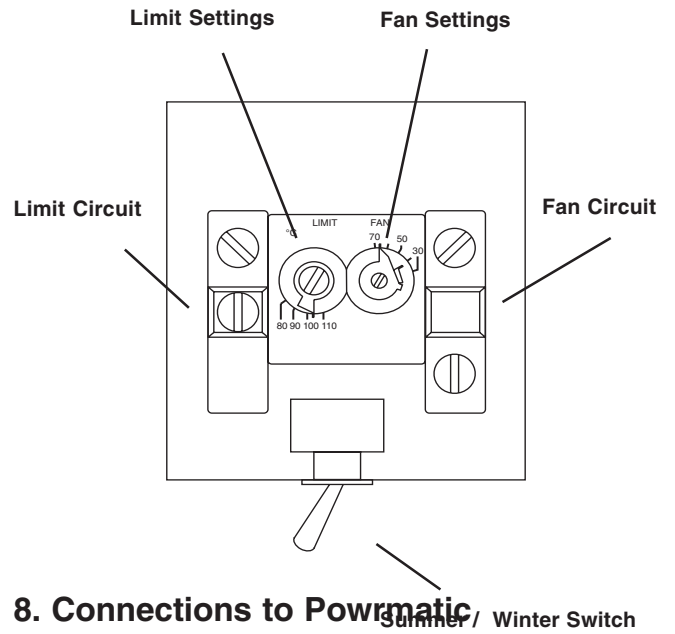
Fan ON	50°C
Fan OFF	30°C
Limit	100°C

**7.4.5.3 EA-G 500 - EA-G 2000 - High Limit Thermostat.**

1. Release the two screws securing the limit thermostat housing cover and remove cover by pulling forward.
2. Release the thermostat from the front cover, two screws
3. Pull off wiring connectors at the rear of the thermostat.
4. Remove the head base or a top side panel from the heater to gain access to the heat exchanger and release the thermostat sensing phial from its holder on top of the heat exchanger and withdraw thermostat and phial.
5. Reassemble new unit in reverse order referring to the heater wiring diagram to ensure correct wiring location.
6. Ensure that the setting is as follows:-
 

Limit	100°C
-------	-------

**Fig 5 White Rodgers 5F464**



**8. Connections to Powrmatic External Controls**

**8.1 Powrtrol**

EA-G Terminals	connect to	Powrtrol Terminals
1		1
2		2
8		5
9		6

**8.2 Eurotrol**

EA-G Terminals	connect to	Eurotrol Terminals
1		CTRL CCT
2		CTRL CCT
8		FAN CCT
9		FAN CCT

## 9. Fault Finding

Refer also to the burner supplement supplied with the heater

<b>Fault</b>	<b>Cause</b>	<b>Action</b>
Main burner will not light	Electrical	<ol style="list-style-type: none"><li>1. Check electrical and gas supplies are ON.</li><li>2. Check controls are ON or calling for heat.</li></ol>
Main burner lights, but goes out before main fan comes on.	Electrical	<ol style="list-style-type: none"><li>1. Unit goes out on high limit -<ol style="list-style-type: none"><li>a. Check fan thermostat setting - <i>See Section 7.6.5.</i></li><li>b. Faulty fan thermostat - change</li><li>c. Check limit thermostat setting - <i>See Section 7.6.5.</i></li><li>d. Faulty limit thermostat - change.</li></ol></li><li>2. Faulty fan assembly - change.</li><li>3. (Ducted Units Only) -fan motor out on thermal overload. - Check running amps. <i>See table 4.- check duct resistance See Table 5.</i></li></ol>
Main fan runs continuously	Electrical	<ol style="list-style-type: none"><li>1. Summer/Winter switch set to Summer.</li><li>2. Fan thermostat set too low - check setting <i>See Section 7.6.5</i></li><li>3. Faulty fan thermostat - change</li></ol>
Main fan fails to run	Electrical	<ol style="list-style-type: none"><li>1. Fan motor or capacitor failed - replace.</li><li>2. Fan thermostat faulty - replace.</li><li>3. Fan contactor failed - replace (3ph units)</li></ol>

## 10. Short List of Parts

Refer also to the burner supplement supplied with the heater.

Refer to Powrmatic Ltd for the details of any parts not listed here.

ITEM	APPLICATION	PART NUMBER
Johnson Controls GM-7742-3503 - ½"BSP.	100,150,400 - 2000	141379957
Johnson Controls GM-2540-2000 - ¾"BSP.	200 - 600	141379954
Johnson Controls GM-2040-2000 - 1"BSP.	700 - 800	141379955
Johnson Controls GM-4540-3000 - 1½"BSP.	1000 - 2000	141379967
Thermostat - Fan / Limit Honeywell L4064	100 - 300	143000303
Thermostat - Fan / Limit White Rogers 5F46-4	400 - 2000	143000331
Thermostat - Limit Landis & Gyr RAK 21.4/2926	400 - 2000	142403597
Contactora - Danfoss CI 9	All	143000608
Overload - Danfoss TI 16 (0.6 - 0.92A)	100 (3ph)	143056103
Overload - Danfoss TI 16 (1.2 - 1.9A)	150 (3ph), 200 (3ph)	143000861
Overload - Danfoss TI 16 (2.7 - 4.2A)	300 (3ph),400	143000706
Overload - Danfoss TI 16 (4.0 - 6.0A)	500 - 800, 1500	143000707
Overload - Danfoss TI 16 (8.0 - 12.0A)	1000	143000770
Overload - Danfoss TI 16 (11.0 - 16.0A)	2000	143000850
Y - Δ Starter - Danfoss SDI 12 047 L1280-38	1000LHP, 1500	143070226
Heat Exchanger Cleanout Door Gasket.	All	170246006
Pressure Relief Door Gasket - 114mm dia.	All	142202110
Pressure Relief Door Gasket - 95mm dia.Heat.	All	142202257
Pressure Relief Door Gasket - 166mm x 166mm.	All	142202310
Burner Gasket - Nu-Way PCGS 2/3/5.	100 - 500	144704004
Burner Gasket - Nu-Way PCGS 8.	600	144704015
Burner Gasket - Nu-Way PCGS 13/25	700 - 2000	144704024
Burner Gasket - Riello GS5.	100	141937080
Burner Gasket - Riello GS10.	150 - 300	141930806
Burner Gasket - Riello GS20.	400 - 600	142931252
Burner Gasket - Riello Gas 3	700 - 1000	142931240
Burner Gasket - Riello Gas 5	1500 - 2000	142931245





HEATING DIVISION  
Winterhay Lane  
Ilminster, Somerset TA19 9PQ  
Tel: 01460 53535 Fax: 01460 52341

**BSI Registered Firm**

FM 414  
Ind. & Comm. Air Heaters;  
Air Moving Equipment;  
Flues & Chimneys; Natural  
Smoke & Heat Ventilators;  
Powered Supply & Extract  
Fans & Systems.

