

# POTTERTON

## Promax System HE

Wall Mounted Powered Flue Condensing Boiler  
Gas Fired Central Heating Unit

---

### User's Operating Instructions

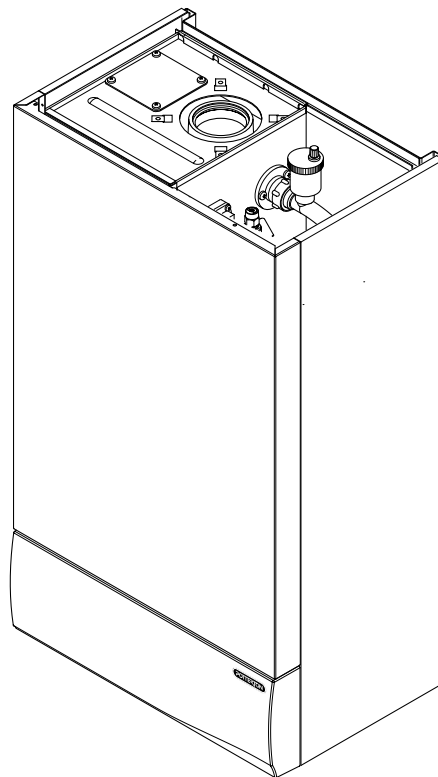

Please keep these instructions safe.  
Should you move house, please hand  
them over to the next occupier.

## Natural Gas

Potterton Promax System HE  
G.C.N° 41 590 69



## Guarantee

Your Potterton Promax System HE is designed and produced to meet all the relevant Standards.

Potterton provide a 12 month guarantee on the boiler. The guarantee operates from the date installation is completed for the customer who is the original user.

To maximise the benefit from our guarantee we urge you to return the reply-paid guarantee registration.

This does not in any way prejudice your rights at Common Law. Such rights between the customer and the installer or supplier from whom the unit was purchased remain intact.

Any component or part which becomes defective during the guarantee period as a result of faulty workmanship or material whilst in normal use will be repaired or replaced free of charge.

The boiler meets the requirements of Statutory Instrument "The Boiler (Efficiency) Regulations 1993 N° 3083" and is deemed to meet the requirements of Directive 92/42/EEC on the energy efficiency requirements for new hot water boilers fired with liquid or gaseous fuels:-

Type test for purpose of Regulation 5 certified by:  
Notified Body 0086.

Product/Production certified by:  
Notified Body 0086.

For GB/IE only.

### B.S. Codes of Practice

Standard	Scope
BS 6891	Gas Installation.
BS 5546	Installation of hot water supplies for domestic purposes.
BS 5449 Part 1	Forced circulation hot water systems.
BS 6798	Installation of gas fired hot water boilers.
BS 5440 Part 1	Flues.
BS 5440 Part 2	Ventilation.
BS 7074	Expansion vessels and ancillary equipment for sealed water systems.
BS 7593	Treatment of water in domestic hot water central heating systems.

**IMPORTANT** - Care must be exercised when lifting and handling this product. Seek assistance where appropriate and avoid stooping. Protective equipment (e.g. gloves) should be worn as necessary.

## 1.0 Warnings

### 1.1 Safe Installation

1. The installation must be carried out by a CORGI Registered Installer or other registered competent person and be in accordance with the relevant requirements of the current **GAS SAFETY** (Installation and Use) **REGULATIONS**, the **BUILDING REGULATIONS** (Scotland)(Consolidation), the **LOCAL BUILDING REGULATIONS**, the current **I.E.E. WIRING REGULATIONS** and the bye laws of the **LOCAL WATER UNDERTAKING**. Where no specific instruction is given reference should be made to the relevant **BRITISH STANDARD CODES OF PRACTICE**. For Ireland install in accordance with IS 813 "INSTALLATION OF **GAS APPLIANCES**". Reference should also be made to **BRITISH GAS GUIDANCE NOTES FOR THE INSTALLATION OF DOMESTIC GAS CONDENSING BOILERS**.

2. **This appliance must be installed in accordance with the manufacturer's instructions and the rules in force, and only used in a suitably ventilated location.**

3. **Read the instructions before installing or using this appliance.**

4. Any purpose provided ventilation should be checked periodically to ensure that it is free from obstruction.

**IMPORTANT** - The addition of anything that may interfere with the normal operation of the appliance without the express written permission of Potterton could invalidate the appliance warranty and infringe the **GAS SAFETY** (Installation and Use) **REGULATIONS**.

### 1.2 In case of gas leaks

1. **If a gas leak is found or suspected**, turn off the gas supply at the meter immediately and at the isolating valve on the boiler if possible. Contact your Installer or Transco (under 'Gas' in the phone directory). **Do not operate any electrical equipment or light switches.**

### 1.3 Servicing your Appliance

1. For reasons of safety and economy your appliance should be serviced annually. Your Installer or British Gas Service will be able to advise you.

### 1.4 Electricity Supply

1. **THIS APPLIANCE MUST BE EARTHED.**

2. A standard 230V ~ 50Hz supply is required. The appliance must be protected by a 3 amp fuse.

#### "Benchmark" Installation, Commissioning and Service Record Log Book

Please ensure that your installer has completed the Installation and Commissioning sections of the Log Book and hands the Log Book over. The details of the Log Book will be required in the event of any warranty work. Keep the Log Book in a safe place and ensure that the relevant sections are completed at each subsequent regular service visit.

All CORGI registered installers carry a CORGI identification card and have a registration number. Both should be recorded in your boiler Log Book. You can check your installer is registered by telephoning 01256 372300 or writing to:-  
1 Elmwood,  
Chineham Business Park,  
Crockford Lane,  
Basingstoke.  
RG24 8WG.

**Never Hang any Items Over  
The Appliance**

## 2.0 Operating the Boiler

### 2.1 Operating the Boiler

1. Hinge the lower door panel down (Fig. 1).
2. Turn on the main gas and electricity supplies to the appliance.
3. Set the boiler thermostat control knob to the required setting (Fig. 2). (The optimum boiler setting depends upon type of system, external controls and your requirements. Your installer will be able to advise you on this matter.)
4. The fan will start to run and after a short period, the ignition spark will commence. Sparking will continue until the flame is established. Check that both the Mains ON light and Boiler ON light are on. Mains ON is indicated by green and Boiler ON by yellow (Fig. 3).
5. Flashing Mains ON light indicates that there is a mains electrical supply to the boiler, but the control knob is in the OFF position. Turn the control knob on and ignition will start.

### 2.2 To shut down the Boiler

1. Turn off the electricity supply to the appliance at the mains.
2. Turn the boiler thermostat control knob to OFF "●" (Fig. 2), then turn off the gas supply at the appliance gas tap.

### 2.3 Frost Protection

1. The boiler does not have integral frost protection. It is recommended that the installer fits a suitable protection device to the system controls if required. For frost protection the boiler must be turned on.

### 2.4 Central Heating System Pressure

1. The water pressure in the central heating system is indicated by the pressure gauge.
2. The normal operating pressure is the range between 1 and 2.5 (Fig. 4).
3. A pressure of 3 or greater indicates a fault. The safety pressure relief valve will operate, at a pressure of 3 (Fig. 5). It is important that your Service Engineer is contacted as soon as possible.
4. The MINIMUM pressure for correct operation is 1. If the pressure falls below 1, this may indicate a leak on the central heating system (Fig. 6).
5. The system must be re-pressurised by your Service Engineer.

### 2.5 In Operation

1. The Promax System HE is a high efficiency "condensing boiler". In common with other condensing boilers its exceptional efficiency means the flue gases are cooled to such an extent that steam is often visible at the outside flue terminal. The amount produced depends on system design, product use and outside air temperature but it is not harmful to the individual or the working of the appliance in any way.

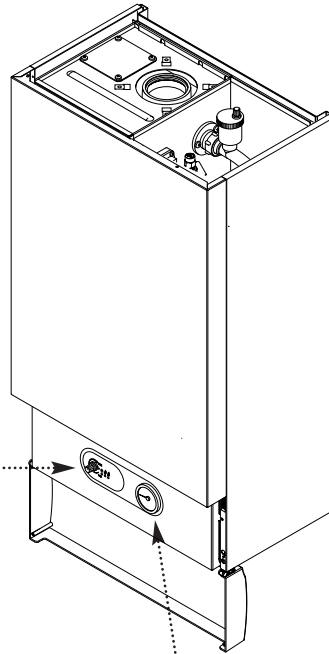

Fig. 1

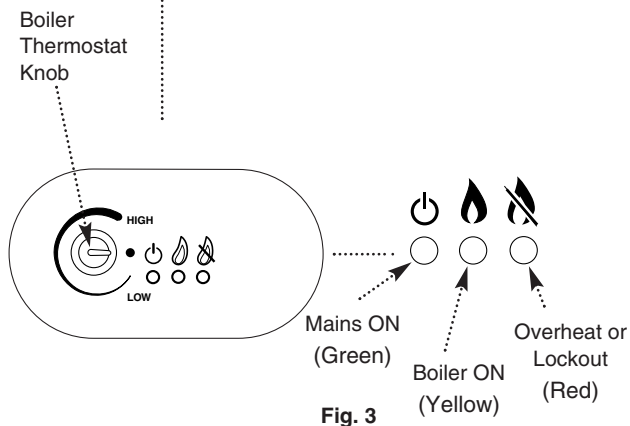

Fig. 2

Fig. 3

Pressure Gauge

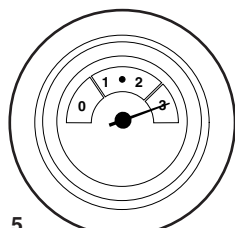

Fig. 5

Fault

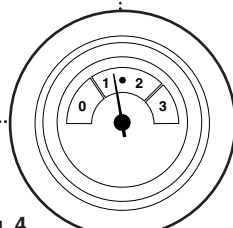

Fig. 4

Normal Pressure

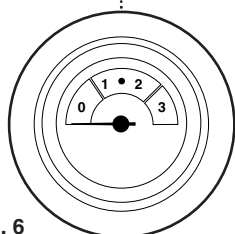

Fig. 6

Below Minimum

## 3.0 Safety Devices

### 3.1 Operation of Safety Devices

1. Your Potterton Promax System HE is fitted with safety devices which shut down the appliance if:
  - a) the system overheats.
  - b) the condensate drain is blocked.
  - c) there is no gas to the boiler.
2. The lockout indicator light will be either flashing or permanently illuminated and the boiler will need resetting (Fig. 7).

**NOTE:** In the case of persistent operation of the devices, turn off the boiler and consult your service engineer as an appliance or system fault is indicated.

### 3.2 Resetting

#### TO RESET THE BOILER

1. Allow the boiler to cool if hot.
  2. Hinge the lower door panel down (Fig. 8).
  3. **If the lockout indicator light is flashing once a second, follow these instructions.**
  4. Turn the boiler thermostat control knob fully anti-clockwise to the OFF position marked “●” (Fig. 9).
  5. Wait 10 seconds and then turn the boiler thermostat control knob clockwise to the required thermostat setting. The overheat light will go out and the boiler will fire up automatically when it has cooled sufficiently.
  6. **If the lockout indicator light is permanently illuminated, follow these instructions.**
  7. Check that the gas supply to the appliance has not been inadvertently turned off.
  8. Check the condensate drain outlet has not been blocked.
- WARNING:** The condensate outlet must not be blocked or modified.
9. Turn the boiler thermostat control knob fully anti-clockwise to the OFF position marked “●” (Fig. 9).
  10. Wait 10 seconds and then turn the boiler thermostat control knob clockwise to the required thermostat setting. The overheat or lockout light will go out and the boiler will fire up automatically.

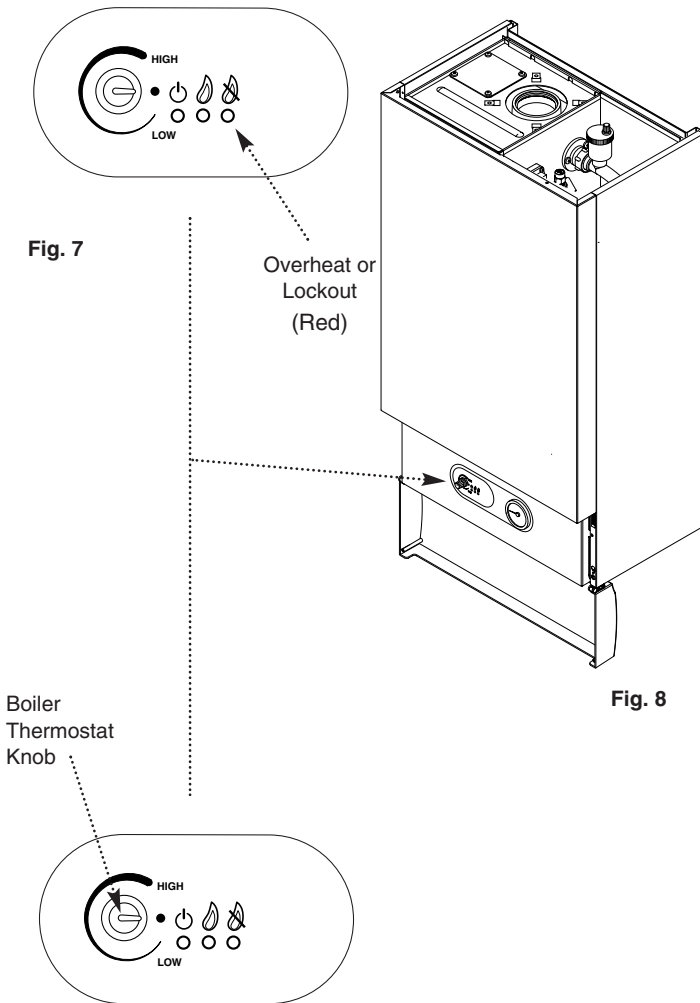

Fig. 7

Overheat or Lockout (Red)

Fig. 8

Boiler Thermostat Knob

Fig. 9

## 4.0 Clearances

### 4.1 Clearances around the Boiler (Figs. 10 & 11)

1. The minimum clear spaces needed around the boiler are:

Top	- 200mm
Bottom	- 200mm
Both sides	- 5mm
Front	- 500mm (For Servicing)
	- 5mm (In Operation)

2. The boiler may be installed in an **unventilated** cupboard or compartment if the following minimum clearances are maintained:

Top	- 200mm
Bottom	- 200mm
Sides	- 25mm
Front	- 100mm

3. Any compartment should be large enough to house the boiler only.

4. **IT SHOULD NOT BE USED AS A STORAGE CUPBOARD.**

5. The gas burning compartment of your boiler is completely sealed from the room in which it is fitted. Products from the combustion of gas are vented to the outside through the flue terminal which must be kept free from obstruction as this would interfere with the correct operation of the boiler.

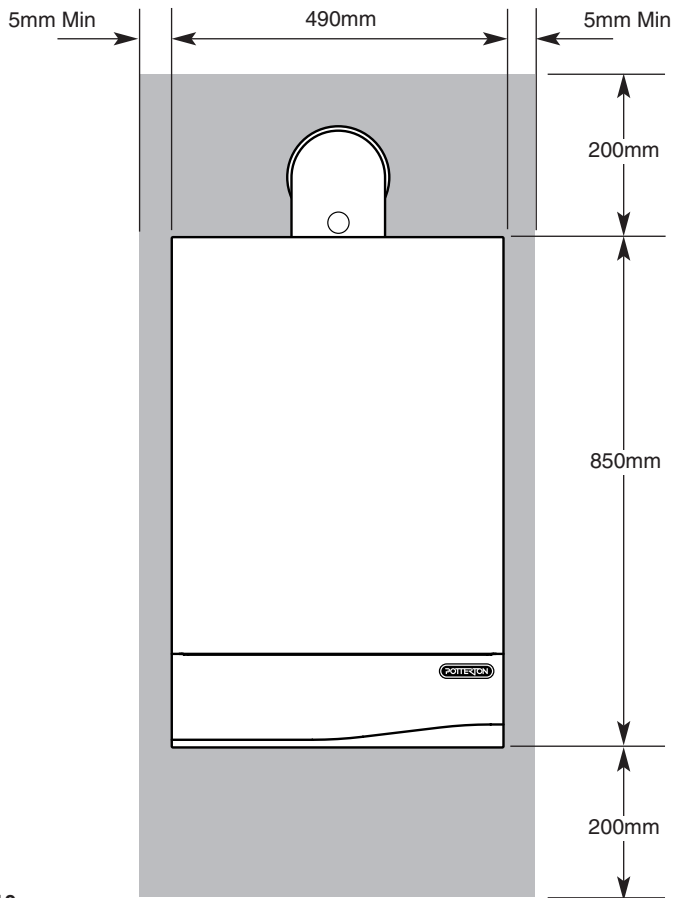

Fig. 10

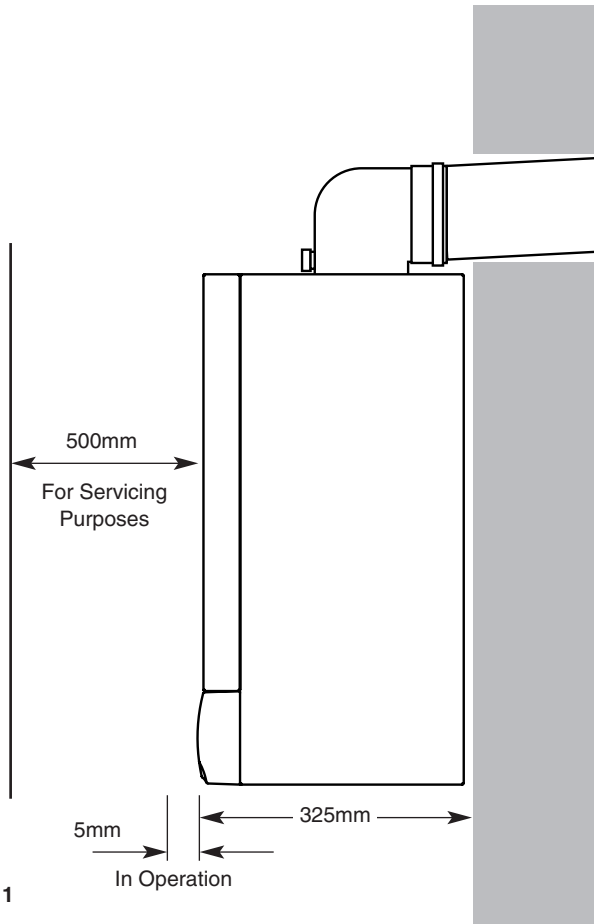

Fig. 11

## 5.0 Cleaning, Spares & Guarantee

---

### 5.1 Cleaning the Outercase

The painted panels should be wiped with a damp cloth and then dried completely. **DO NOT USE ABRASIVE CLEANING AGENTS.**

---

### 5.2 Spare Parts

Repairs should be carried out by a CORGI Registered Installer or other Registered Person

1. Any repairs to the boiler will usually be the responsibility of the Installer during the guarantee period after which spare parts may be obtained through approved Potterton stockists if required.
  2. Quote the appliance name, model number (found on the reverse of the lower door panel) and where possible the part number when ordering spares. A short parts list is included in the Installation and Servicing Instructions.
- 

### 5.3 Guarantee

1. Your Potterton Promax System HE is designed and produced to meet all the relevant Standards.
2. Potterton provide a 12 month guarantee on the boiler. The guarantee operates from the date installation is completed for the customer who is the original user.
3. To maximise the benefit from our guarantee we urge you to return the reply-paid guarantee registration.
4. This does not in any way prejudice your rights at Common Law. Such rights between the customer and the installer or supplier from whom the unit was purchased remain intact.

**Any component or part which becomes defective during the guarantee period as a result of faulty workmanship or material whilst in normal use will be repaired or replaced free of charge.**

---

# POTTERTON

Potterton, Baxi UK Limited, Brownedge Road, Bamber Bridge, Preston, Lancashire. PR5 6SN  
After Sales Service 08706 096 096  
[www.baxi.com](http://www.baxi.com)