

POTTERTON

Osprey 2 CFL 125 - 150 - 180 - 220

Gas Fired Floor Standing Boiler

Users Operating Instructions

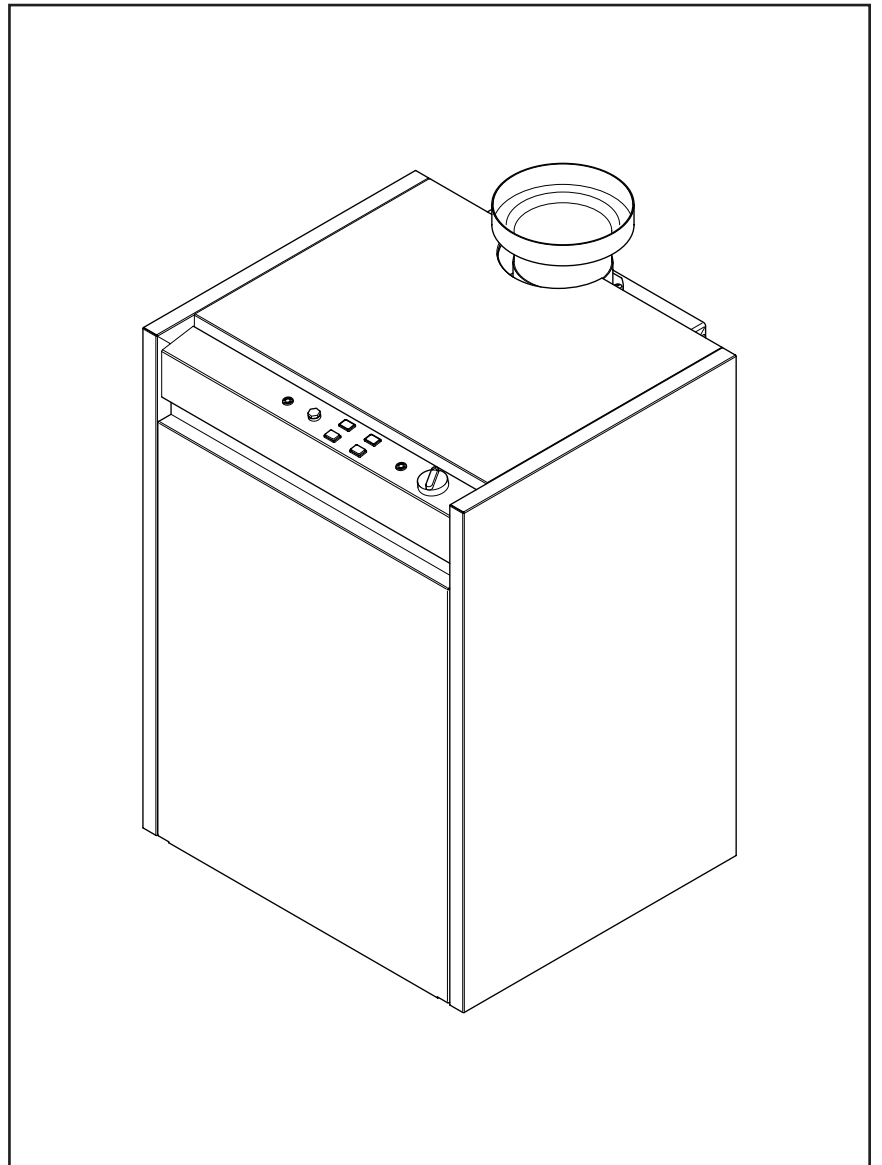

Please leave these instructions with the user

Natural Gas

Potterton Osprey 2 CFL 125
G.C.N° 41 590 54

Potterton Osprey 2 CFL 150
G.C.N° 41 590 55

Potterton Osprey 2 CFL 180
G.C.N° 41 590 56

Potterton Osprey 2 CFL 220
G.C.N° 41 590 57



The boiler meets the requirements of Statutory Instrument “ The Boiler (Efficiency) Regulations 1993 N° 3083” and is deemed to meet the requirements of Directive 92/42/EEC on the energy efficiency requirements for new hot water boilers fired with liquid or gaseous fuels:-

Type test for purpose of Regulation 5 certified by:
Notified Body 0049.

Product/Production certified by:
Notified Body 0049.

For GB/IE only.

Guarantee

Your Potterton Osprey 2 CFL is designed and produced to meet all the relevant Standards.

Potterton provide a 12 month guarantee on the boiler. The guarantee operates from the date installation is completed for the customer who is the original user.

To maximise the benefit from our guarantee we urge you to return the reply-paid guarantee registration.

This does not in any way prejudice your rights at Common Law. Such rights between the customer and the installer or supplier from whom the unit was purchased remain intact.

Any component or part which becomes defective during the guarantee period as a result of faulty workmanship or material whilst in normal use will be repaired or replaced free of charge.

STANDARD	SCOPE
B.S. 6891	Gas Installation.
B.S. 5440: Pt 1	Flues.
B.S. 5440: Pt 2	Ventilation.
B.S. 5546	Installation of hot water supplies for domestic purposes.
B.S. 7074	Expansion vessels and ancillary equipment for sealed water systems.
B.S. 5449	Forced circulation hot water systems.
B.S. 6798	Installation of gas fired boilers.

“Benchmark” Installation, Commissioning and Service Record Log Book

Please ensure that your installer has completed the Installation and Commissioning sections of the Log Book and hands the Log Book over. The details of the Log Book will be required in the event of any warranty work. Keep the Log Book in a safe place and ensure that the relevant sections are completed at each subsequent regular service visit. All CORGI registered installers carry a CORGI identification card and have a registration number. Both should be recorded in your boiler Log Book. You can check your installer is registered by telephoning 01256 372300 or writing to:-
1 Elmwood,
Chineham Business Park,
Crockford Lane,
Basingstoke
RG24 8WG

1.0 Warnings

1.1 Safe Installation

1. The appliance is suitable for installation only in G.B. and I.E. and should be installed in accordance with the rules in force. For Ireland install in accordance with I.S.813 “**INSTALLATION OF GAS APPLIANCES**”. The installation must be carried out by a CORGI Registered Installer or other registered competent person and be in accordance with the relevant requirements of current **GAS SAFETY** (Installation and Use) **REGULATIONS** most recent edition, the **BUILDING REGULATIONS** issued by the Department of the Environment, **BUILDING STANDARDS** (Scotland) (Consolidation) **REGULATIONS** issued by the Scottish Development Department and the **LOCAL BUILDING REGULATIONS**. Where no specific instructions are given, reference should be made to the relevant **BRITISH STANDARD CODES OF PRACTICE and INSTALLATION SPECIFICATIONS**.

2. **This appliance must be installed in accordance with the manufacturer’s instructions and the rules in force, and only used in a suitably ventilated location.**

3. **Read the instructions before installing or using this appliance.**

4. Any purpose provided ventilation (see Section 3.0) should be checked periodically to ensure that it is free from obstruction.

IMPORTANT - The addition of anything that may interfere with the normal operation of the appliance without the express written permission of Potterton could invalidate the appliance warranty and infringe the **GAS SAFETY** (Installation and Use) **REGULATIONS**.

1.2 In case of gas leaks

1. **If a gas leak is found or suspected**, turn off the gas supply at the meter immediately and contact your Installer or Transco (under ‘Gas’ in the ‘phone directory).

1.3 Servicing your Appliance

1. For reasons of safety and economy your appliance should be serviced annually. Servicing must be performed by a competent person. Your Installer or British Gas Service will be able to advise you.

1.4 Electricity Supply

1. **THIS APPLIANCE MUST BE EARTHED.**

2. A standard 230V ~ 50Hz supply is required. The appliance must be protected by a 3 amp fuse.

Never Hang Flammable Items Over The Appliance

2.0 Operating the Boiler

2.1 Introduction

1. Your Potterton Osprey 2 CFL is a gas fired, open flue, floor standing boiler. The boiler can be used to supply hot water for central heating, and domestic hot water when used in conjunction with an indirect cylinder.

2. The boiler is designed for use on fully pumped open vented or sealed systems. It can be used on Natural Gas (G20) only.

3. Instructions for use can also be found behind the boiler front panel (Fig. 1).

2.2 Operating the Boiler

1. Ensure that the gas and electricity supplies are turned on and that all timers, thermostats etc. are calling for heat.

2. The Power On neon should be illuminated.

3. Push the On/Off button in. The button will illuminate and the ignition sequence will start.

4. The pilot flame will light followed by the main burner. This is indicated by the Burner On neon illuminating.

5. The optimum setting of the boiler temperature control depends upon type of system, external controls and your requirements. Your Installer will be able to advise you on this matter.

2.3 Flame Failure

1. If at any time the burner is extinguished while there is still a demand for the boiler to operate the Flame Failure neon will illuminate. The Burner On neon will extinguish.

2. Pressing the Flame Failure reset button will restart the ignition sequence.

3. If the Flame Failure neon illuminates repeatedly a fault is indicated. Your Service Engineer should be contacted as soon as possible.

2.4 Boiler Safety Overheat Thermostat

1. The boiler is fitted with an additional safety device, which shuts down the boiler in the event of the system or the boiler overheating.

2. If the device operates, the Boiler Safety Overheat neon will illuminate and the boiler will shut down.

3. Unscrew the cap off the Boiler Safety Overheat Reset. Press the reset button to restart the ignition sequence.

4. If the Boiler Safety Overheat neon illuminates repeatedly a fault is indicated. Your Service Engineer should be contacted as soon as possible.

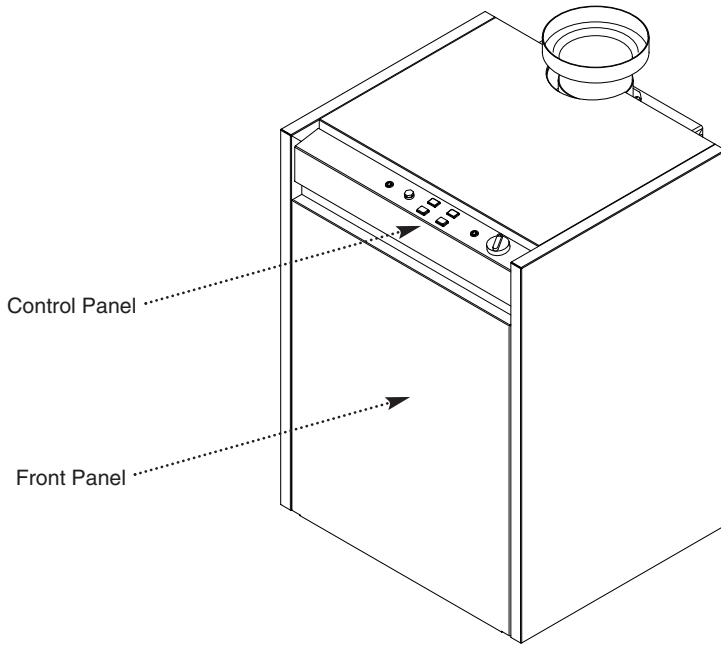

Fig. 1

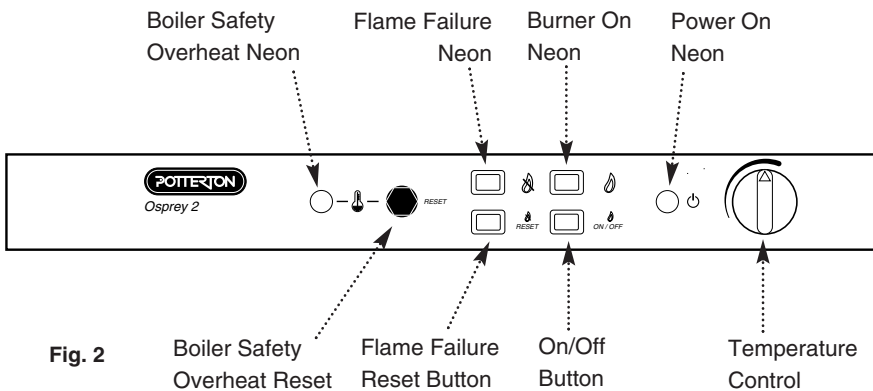

Fig. 2

2.0 Operating the Boiler

2.5 Flue Safety Thermostat

1. The boiler is fitted with a safety thermostat in the flue draught diverter.
2. If the flue becomes blocked or is subjected to adverse conditions the safety thermostat will operate and shut down the boiler. The Burner On neon will extinguish.

Note: The Flame Failure neon and Boiler Safety Overheat neon will not illuminate if the Flue Safety Thermostat is activated. After approximately 10 minutes the boiler will relight if there is still a demand for heat.

3. If the blockage or adverse condition persists the safety thermostat will continue to operate and cycle the boiler on and off. As a result the boiler may not be able to supply adequate hot water for heating and/or domestic purposes.
4. Under normal circumstances the boiler will cycle on and off as dictated by the Temperature Control Thermostat. If the cycling appears to be excessive with long periods where the boiler is off and the heating/hot water performance is diminished turn the boiler off and contact your Service Engineer as soon as possible.

2.6 To Shut Off the Boiler

1. **For short periods:** Press the On/Off Button so that it is not illuminated.
2. **For longer periods:** Turn off the electricity and gas supplies.

If your home is to be left unoccupied for long periods during cold weather the boiler and whole system should be drained unless there is additional frost protection.

3. Your Installer will advise you about frost protection and draining the system.
-

3.0 Clearances & Ventilation

IMPORTANT - If the boiler is not already in a compartment and you wish to enclose it consult your installer before commencing any work. Specific details of compartments and their ventilation are included in the Installation Instructions, and reference made to the relevant British Standards.

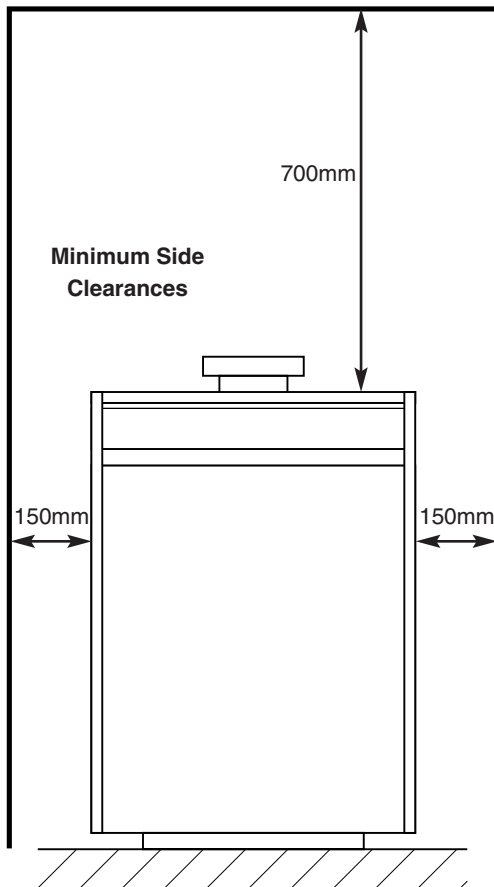

Fig. 3

3.1 Clearances around the Boiler (Figs. 3 & 4)

1. The minimum clear spaces needed around the boiler measured from the casing are as follows:-

Top	-	700mm
Sides	-	150mm
Front	-	700mm
Rear	-	200mm

2. **These areas must not be obstructed in any way. Blocking the clearance spaces may result in the boiler overheating and damage may occur. The ventilation will also be affected** (see below).

3. Any combustible material must be at least 25mm from the flue pipe at any point along the length of the pipe.

4. Any compartment should be large enough to house the boiler and ancillary equipment only providing that the minimum clearances are adhered to.

IT SHOULD NOT BE USED AS A STORAGE CUPBOARD.

3.2 Ventilation

1. The Osprey 2 CFL is an open flue appliance that takes air for combustion from the room or compartment in which it is installed (**Note: Only 125 & 150 models can be fitted in conventional compartments. 180 & 220 models have special requirements**).

2. The room or compartment will incorporate air vents which must not be blocked or obstructed in any way. If these vents do not communicate directly with outside there will be further vents in adjoining rooms. These vents must also not be blocked or obstructed.

3. Details of ventilation requirements are given in the Installation and Servicing Instructions.

4. If any building work or alterations are carried out that may affect the ventilation consult your Installer who will advise if further vents are required.

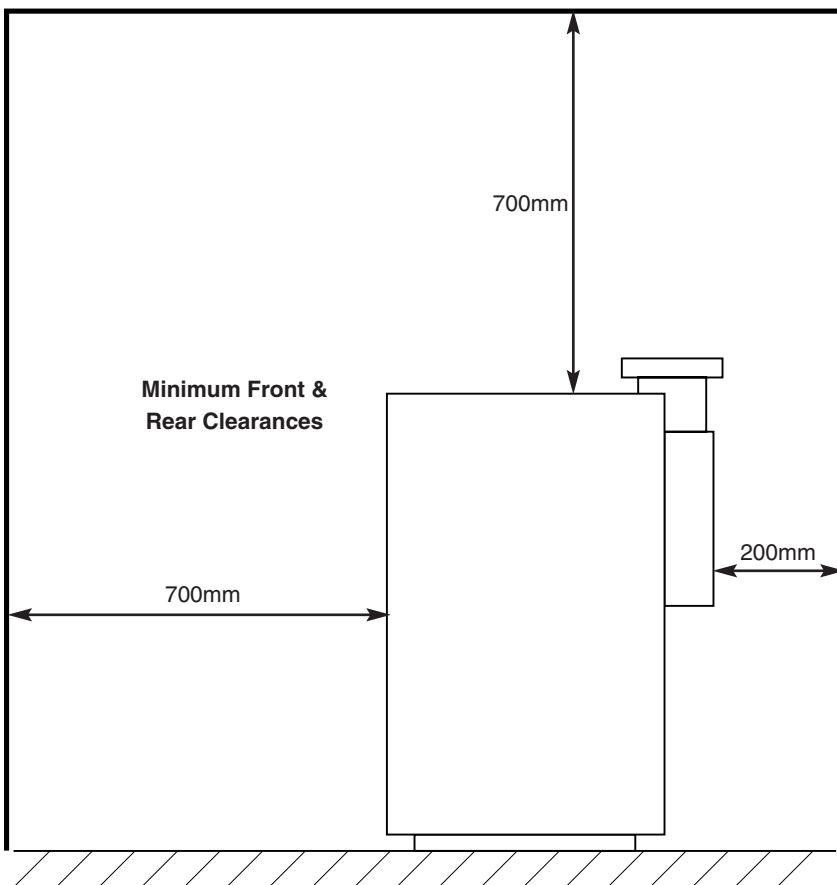

Fig. 4

4.0 Check List, Cleaning, Spares & Guarantee

4.1 Check List

1. If a fault develops, or is suspected, call your Service Engineer as soon as possible.
2. Go through the following check list before you make contact.
 - a) Are the gas and electricity supplies on ?
 - b) Is the On/Off button in the on position ?
 - c) Is the Flame Failure neon illuminated ?
If so, press the Reset Button.
 - d) Is the Boiler Safety Overheat Neon illuminated ?
If so, remove the cover and press the Boiler Safety Overheat Reset.
 - e) Is the boiler temperature control set high enough ?
 - f) Are the time clock and room thermostat (where fitted) calling for heat ?
 - g) Are all the radiator valves open ?

4.2 Cleaning the Outercase

The painted panels should be wiped with a damp cloth and then dried completely. **DO NOT USE ABRASIVE CLEANING AGENTS.**

4.3 Spare Parts

IMPORTANT - Only a competent person should be used to service or repair this boiler

1. Any repairs to the boiler will usually be the responsibility of the installer during the guarantee period after which spare parts may be obtained through approved Potterton stockists if required.
2. Quote the appliance name, model number and where possible the part number when ordering spares. The appliance data badge is situated as shown in Fig. 5. A short parts list is included in the Installation and Servicing Instructions.

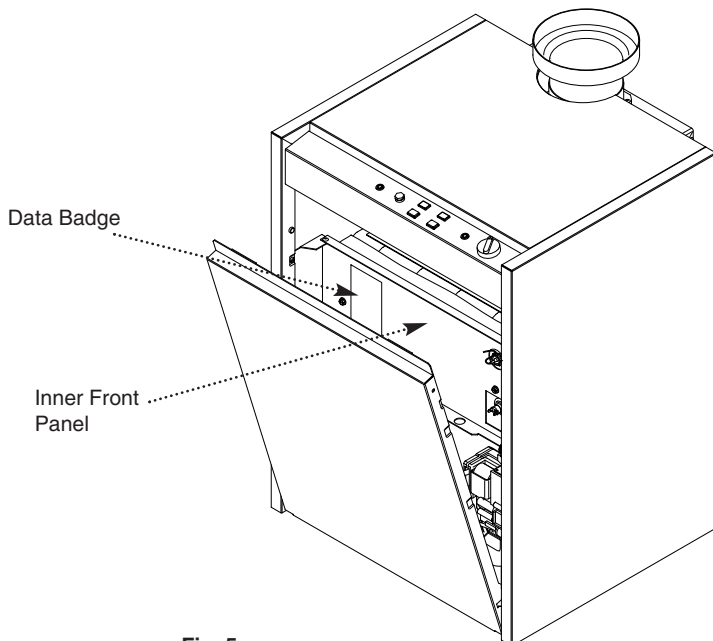

Fig. 5

POTTERTON

Potterton, Baxi UK Limited, Brownedge Road, Bamber Bridge, Preston, Lancashire. PR5 6SN
After Sales Service 08706 096 096 Technical Enquiries 08706 049 049

www.baxi.com