

Streamline FS 150 & 225

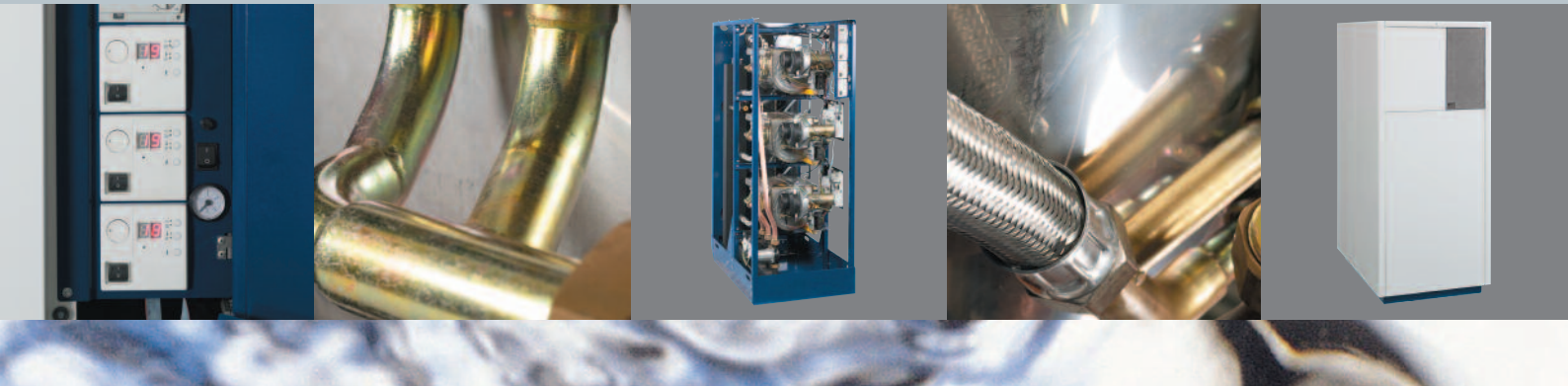

Packaged Modular Boiler Systems incorporating
Two or Three 75kW Low NOx Premix Gas Fired
Condensing Modules in each Cabinet.
Outputs up to 900kW in Cascade Arrangement.

MHS
BOILERS

Power, efficiency, reliability and turndown

Including either two or three 75kW premix gas fired stainless steel condensing modules, the Streamline FS 150 / 225 series appliances are packaged modular boilers which require no site assembly.

With up to 15 to 1 turndown ratio, and completely factory assembled and tested; the Streamline FS boilers have all the facility of rig or frame mounted multiple boiler installations but with the added advantage of being free standing, and having the common flue and combustion air ducts built in to the award winning smart casing.

Available as either single 150kW or single 225kW units, or as Cascade versions where up to six of the smaller models or four of the larger models may be installed together; the Streamline FS boilers are suitable for a host of commercial heating applications.

Based upon the well proven MHS Streamline wall mounted condensing boiler, the Streamline FS Boilers provide for quick and easy installation, inherent modular concept reliability, efficiency up to 109.5% net, up to 15:1 turndown and the facility for room sealed flue applications.

A wide range of matched system controls are also available creating the complete package for efficiency and comfort.



Put your mind at rest

It's easy to ignore your boiler and heating system - until it goes wrong or breaks down. A system failure, especially one caused by lack of maintenance, can be inconvenient and costly.

It isn't hard to imagine the difficulties that problems with your heating system can cause. And in some situations lack of heating and hot water can be critical. Similar to your car, a regularly maintained heating system will run more efficiently and any potential problems can be resolved before they develop into major system failure.

Financially, planned maintenance makes sense too. It avoids major capital outlay and the associated costs of system down time - plus it can keep your fuel costs down as well as ensuring you are minimising your emissions.

At MHS Boilers we provide a lifetime maintenance and service solution for your heating system - enabling you to rest safe in the knowledge that we'll take care of it. Go to **www.mhsboilers.com** and download or request a copy of our **Maintenance and Service Solutions** brochure.



Our highly skilled and trained service and technical support engineers are only a phone call away

Standard features

Compact dimensions

All models are just 1650mm (h) x 680mm w x 1030mm (d) and with a footprint of less than 0.8m² the Streamline FS Boilers make efficient use of valuable building space.

Everything in One Neat Package

A complete modular boiler installation which is factory preassembled, and delivered to site in a stylish design award winning casing; the Streamline FS series of boilers takes the prefabricated rig mounted concept of multiple appliances to the next level by providing everything in one covered package at competitive prices.

High Efficiency / Low Emissions

Calculated in accordance with the formula given in the Non-Domestic Heating, Cooling and Ventilation Compliance Guide (Compliance with Approved Documents L2A & L2B) the Streamline FS 150 and 225 Modular Boilers have Gross Seasonal Efficiencies of 95.9%

The Ultra Clean Radiant Premix Modulating Burner System emits less than 26.7mg/kWh (@ 0% O₂) which easily meets the stringent requirements for the highest BREEAM points score for NO_x pollution.

Ease of Installation

Features such as inbuilt low loss headers (single versions) and collector manifolds (cascade versions), inbuilt common flue and combustion air ducts, all necessary gas and water tubing prefabricated and installed, plus a local transit wheel system which all aid a speedy and problem free installation process.

Direct-on-boiler weather compensation

As a modular boiler, a cascading sequence control device is included which allows direct-on-boiler weather compensated flow temperature to be provided if required. The standard control arrangement also allows for control over a heating circuit and a domestic hot water cylinder if required. This control facility may be expanded if required to control multiple heating and hot water circuits by the addition of matched controls. Alternatively for simplicity and if desired, the Streamline FS boilers will interface with basic external v/f contacts or analog control voltage input, which allows the boiler to integrate with existing control systems or operate with a customer preferred arrangement supplied by others.

Room Sealed Flue Option

The Streamline FS Boilers may be installed with a room sealed flue system if required or be connected as an open flue type appliance and is tested and certified for use with the following flue classifications: B23, C33, C43, C53, C63, C83

Upgrade possibility

If required, at a later stage, the model FS150 may be upgraded to a 225 kW version by the addition of an add-on module kit.

Stainless Steel Construction

Utilising the reliable and proven helical stainless steel tube type heat exchanger pioneered by MHS, the Streamline FS 150 & 225 products accord longevity and peace of mind in the knowledge that robust components are at the heart of this state of the art appliance and carry a 5 Guarantee on the heat exchanger elements.

Easy to handle, easy to install

Every Streamline FS Boilers comes complete with a transit wheel system for ease of maneuvering into the installation position. No raised plinths necessary - boiler(s) can stand directly on boiler house floor.



Dimensions & clearances

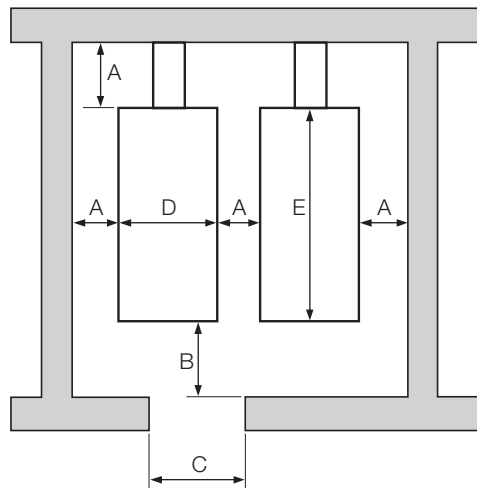
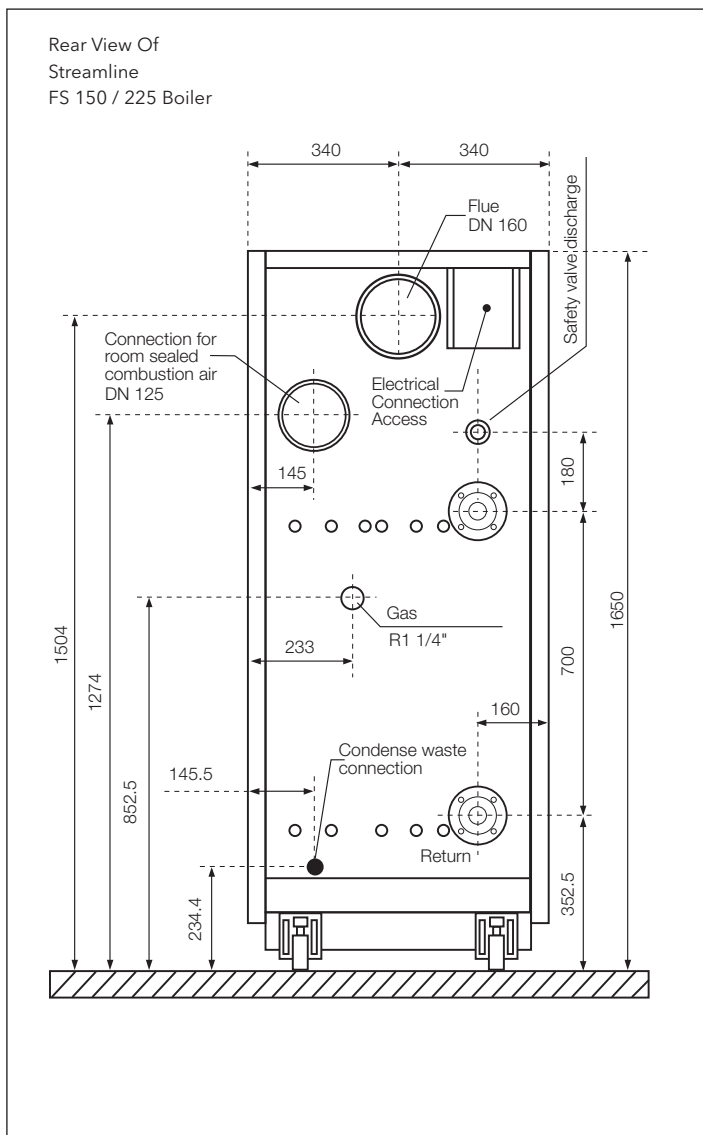

Note: The clearance between, and to the sides of boilers may be reduced to 100mm providing there is free and adequate access to the rear of the boiler/s installation for connection/disconnection of services.

The clearance specified behind must be free of all but essential pipework, electrical and flue services that are connected to the appliance. Common headers, manifolds etc must be outside of the clearance requirement.

Dimension Key	Dimension in mm
A	500
B	1000
C	700
D	680
E	1050

Technical data

Boiler Model		FS 150	FS 225
Product Identification Number		CE-0045BRKD1001	
Category		I12ELL3/P	I12ELL3/P
Nominal Heat Input Net	kW	15.0 - 149.2	15.0 - 216.0
Nominal Heat Output 80/60°C	kW	14.5 - 143.2	14.5 - 206.0
Nominal Heat Output 50/30°C	kW	16.0 - 155.0	16.0 - 225.0
Gas Input Natural Gas G20	m³/h	15.0	21.7
Gas Input LPG G31	m³/h	5.77	8.35
Inlet Gas Pressure G20 Min/Max	mbar	18/30	18/30
Inlet Gas Pressure G31 Min/Max	mbar	30/50	30/50
Max Fluegas Mass G20/G31	kg/h	250.9/231.4	363.6/335.1
Residual Flue Positive Pressure Max	Pa	200	200
Max Flow Temperature	°C	90	90
Water Pressure Min/Max	bar	1.0/3.0	1.0/3.0
Residual Pump Head (Cascade Versions)	kPa	15.0	15.0
Flow/Return Connections Flanged	PN6	DN40	DN40
Gas Connection	BSP	R1 1/4"	R1 1/4"
Flue Connection	Ø	DN160	DN160
Combustion Air Connection	Ø	DN125	DN125
Condense Waste Connection Tail	mm	20	20
Water Content	l	30	35
Weight Dry/Wet	kg	250/280	270/305
Electrical Supply	V/ph/Hz	230/1/50	230/1/50
Power Consumption Max	W	690	800
Design Water Flow Rate @ Δt20°C	l/s	1.80	2.66
Efficiency @ Full Load (Gross)	%	86.48	85.67
Efficiency @ 30 % of Full Load (Gross)	%	98.20	98.37
NOx emission @ 0%O ²	mg/kWh	26.7 (Class 5)	
Flue Classification		B23, C33, C43, C53, C63, C83	

Installation requirements

The Streamline FS series of boilers must be installed in accordance with (as appropriate) the relevant requirements of the Building Regulations, Health and Safety Regulation PM5, IEE Regulations, Gas Safety (Installation & Use) Regulations, National Water Bylaws, Clean Air Act, and any Insurance Company requirements.

Codes of Practice

- BS 6880 Code of Practice for low temperature hot water heating systems for output greater than 45kW, Parts 1, 2 & 3: 1988.
- BS 6644 : 2005. Specification for installation of gas-fired hot water boilers of rated inputs between 70kW (net) and 1.8MW (net) (2nd and 3rd family gases).
- IGE/UP/2 Gas installation pipework, boosters and compressors on industrial and commercial premises.
- IGE/UP/10 Installation of gas appliances in industrial and commercial premises, Part 1: Flued appliances.
- CIBSE Guide Sections B7, B11 and B13.
- CIBSE AM14.
- LPG When boilers are fired with LPG it is advisable that gas leakage detection equipment is installed at low level near the boiler/s.

System Water

Streamline FS series boilers must only be installed onto sealed and pressurised systems with a minimum static pressure of 1bar. All systems must be thoroughly cleansed prior to the connection of the boiler and the system water must be dosed with a good quality treatment to prevent corrosion within the system and the formation of scale within the boiler waterways. The chloride content of the fill water must not exceed 200mg/l. Particular care must be taken when installing the boiler onto an old system, with consideration given to the installation of a dirt arrester/filter or a boiler protection plate heat exchanger. For specialist advice and water treatment products, contact: Fernox, Tandem House, Marlowe way, Beddington Farm Road, Croydon CR0 4XS. Tel: 0208 665 6666 or Betz Dearborn Ltd, Widnes, Cheshire WA8 8UD. Tel: 0151 495 1861

Electrical Connection Detail

A6	MD	H1	M	B3	M	B9	M	DB	MB		N	Q3	⊕	⊕	Q1	N	N	⊕	L
RU		H1		BW		AF		BUS			BUS ⊕			HK ⊕			230V		

Terminal Rail located under cover plate at rear face of boiler - top l/h

Legend:

- RU = Room unit (if fitted (QAA70,QAA50,QAA10)).
- H1 = External Control (if fitted) eg. volt free contacts or analog 0-10V signal.
- BW = Hot Water Sensor QAZ21 or Cylinder Thermostat (if fitted).
- AF = Outside Air Sensor QAC32 or 620Ω substitute resistor.
- BUS = Local Process Bus (LPB) for connection to additional system controls or additional boilers.
Use screened cable observing polarity.
- BW⊕ = Hot Water Primary Pump Max 1Amp (if HWS is to be controlled from boiler).
- HK⊕ = Central Heating Circuit Pump Max 1Amp (if being controlled from boiler).
- 230V = Single Phase 220 - 240V Electrical Supply Input.

Additional Electrical Connection Detail - Applicable to Multiple Boilers Installations only

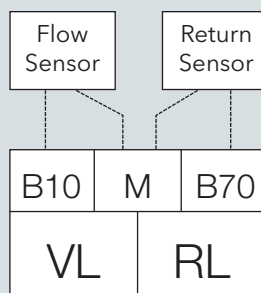

CASCADE MODELS ONLY

Hydraulic schemes

Notes: The Streamline FS Series Boilers are available in two variants:

Single Units which either include two 75kW Boilers within the compact casing (Streamline FS150 with output up to 150kW total with 10:1 turndown), or three 75kW Boilers within the compact casing (Streamline FS 225 with output up to 225kW total with 15:1 turndown). Single units include an in-built low loss header to which the flow and return pipes of the system should be directly connected - see typical schematic diagram Fig.1

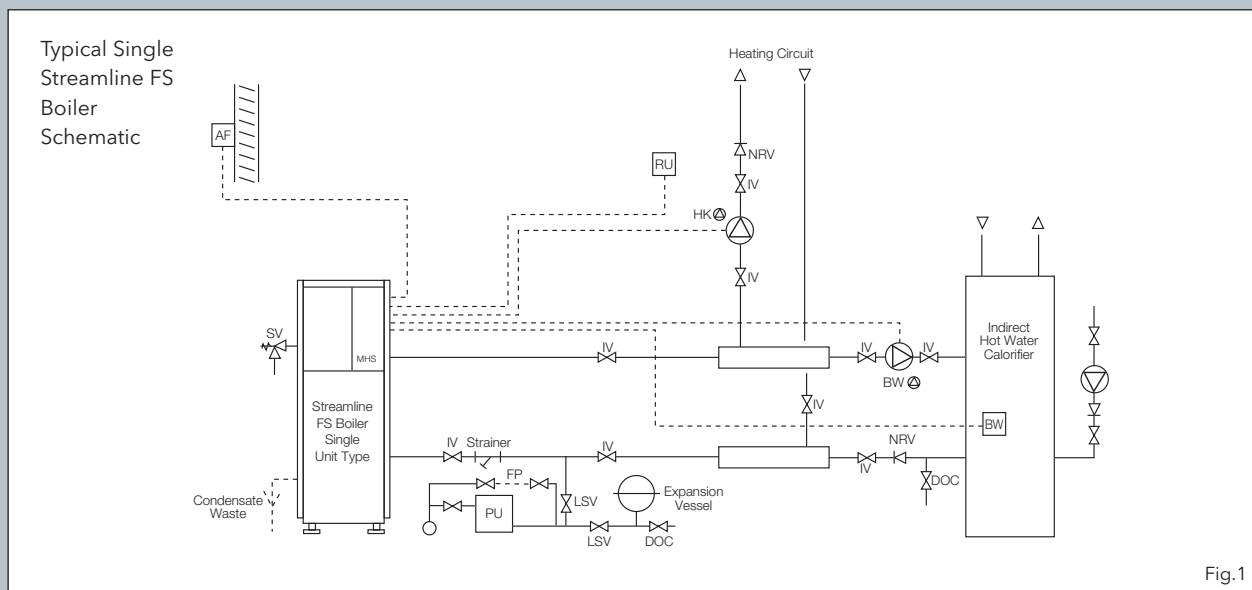

Fig.1

Cascade Units which are available in the same output versions as the single units described above and are identical in every way except that, in place of the in-built low loss header, there is a combined flow and return header. Cascade units are intended to be used in multiples, and up to 12 burner modules may be grouped together to create outputs up to 900kW (12 x 75kW). This grouping may be created using up to 6Nr FS 150 Boilers or 4 Nr FS225 Boilers. When a Cascade Group is installed, Cascade Unit No 1 is the "Master Unit" and all other Units are "Slaves". Cascade groups require a suitably sized external low loss header to be installed - see typical schematic diagram Fig.2

Control Possibilities and Options

As standard, the Streamline FS single boiler unit or cascade master unit has the capability if desired, to control a heating circuit with or without direct-on-boiler weather compensation plus a domestic hot water calorifier as indicated in schematics opposite.

It is possible to enhance and expand the control capability of an installation incorporating Streamline FS Boilers by the addition of matched system controllers. Up to a total of 30 additional controllers may be connected.

Control Options:

RVA 46 Zone Controller - Enables an additional VT heating circuit.

RVA 63.280 Twin Zone Controller - Enables two CT or VT heating circuits heating circuits.

QAA 70 Room Unit, provides remote time and temperature scheduling for heating zones. It is possible to connect a QAA 70 for every heating zone in the scheme.

QAW44 Tamper Proof Remote Room Sensor for use in conjunction with QAA70 Room Unit.

QAA50,(Alternative to QAA70) as QAA70, but with reduced programming functionality.

QAA10 (Alternative to QAA70) Tamper Proof Room Sensor.

Contact MHS or see Installer Guide for specific details for connection and utilisation of additional controls.

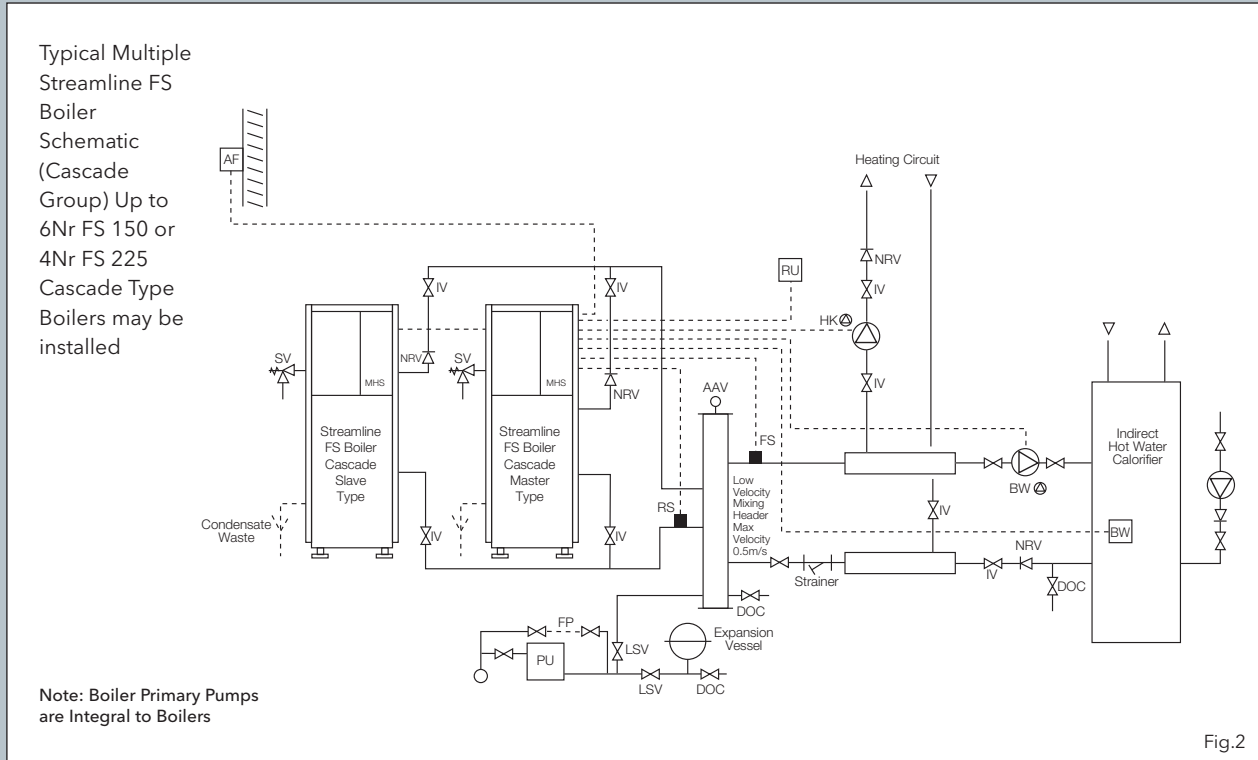

Legend:

- | | |
|---|--|
| AF = Outside Air Temperature Sensor | HK ⊗ = Central Heating Circuit Pump |
| BW = Hot Water Sensor or Thermostat | PU = Automatic system fill unit (pressurisation unit)
Must be installed as a requirement of BS 6644 |
| BW ⊗ = Hot Water Primary Pump | RU = Room unit or Controls by Others eg. BMS System etc |
| FP = Approved method system filling point - see page 7 for acceptable methods | FS = Flow Sensor |
| | RS = Return Sensor |

Filling the system

The Initial filling of a sealed heating system, and subsequent refilling, must be by a method that has been approved by the Water Regulation Advisory Scheme (WRAS) for that type of heating system. i.e. Non Domestic (Other than In-House) Fluid Category 4 (C-4).

For Category 4 systems

The approved method of filling must comprise of the following components in the arrangement shown below.

- Control Valve, on the Mains Cold water pipework
- Strainer
- Verifiable Backflow Device with Reduced Pressure Zone (RPZ Valve) incorporating a 'Type BA' Air Gap
- Tundish
- Control Valve, on the Heating System pipework

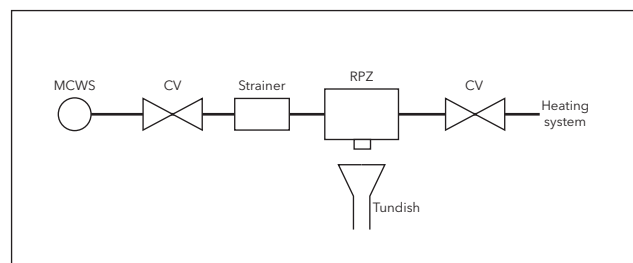



MHS
BOILERS

3 Juniper West, Fenton Way, Southfields Business Park,
Basildon, Essex SS15 6SJ

Tel: 01268 546700 Fax: 01268 888250 www.mhsboilers.com



Authorised User No. 00261



United Registrar of Systems Certificate No. 75710