

# HR100 & HR200 Mk3 SUPPLY & EXTRACT VENTILATION SYSTEMS WITH HEAT RECOVERY

## INSTALLATION, COMMISSIONING AND SERVICING INSTRUCTIONS

Publication No. ZZ 1064/3  
July 2003

### 1. GENERAL INFORMATION

- 1.1 HR100 and HR200 Mk3 heat recovery systems provide whole house mechanical ventilation to living areas and bedrooms, extraction of stale air, contaminated air from kitchens and utility rooms, and recovery of heat from the extracted air to temper the incoming fresh air. The ventilation and stale air streams are separated from each other. HR100 Mk3 delivers 170m<sup>3</sup>/h (100ft<sup>3</sup>/min) of ventilation air, while HR200 Mk3 delivers 340m<sup>3</sup>/h (200ft<sup>3</sup>/min).

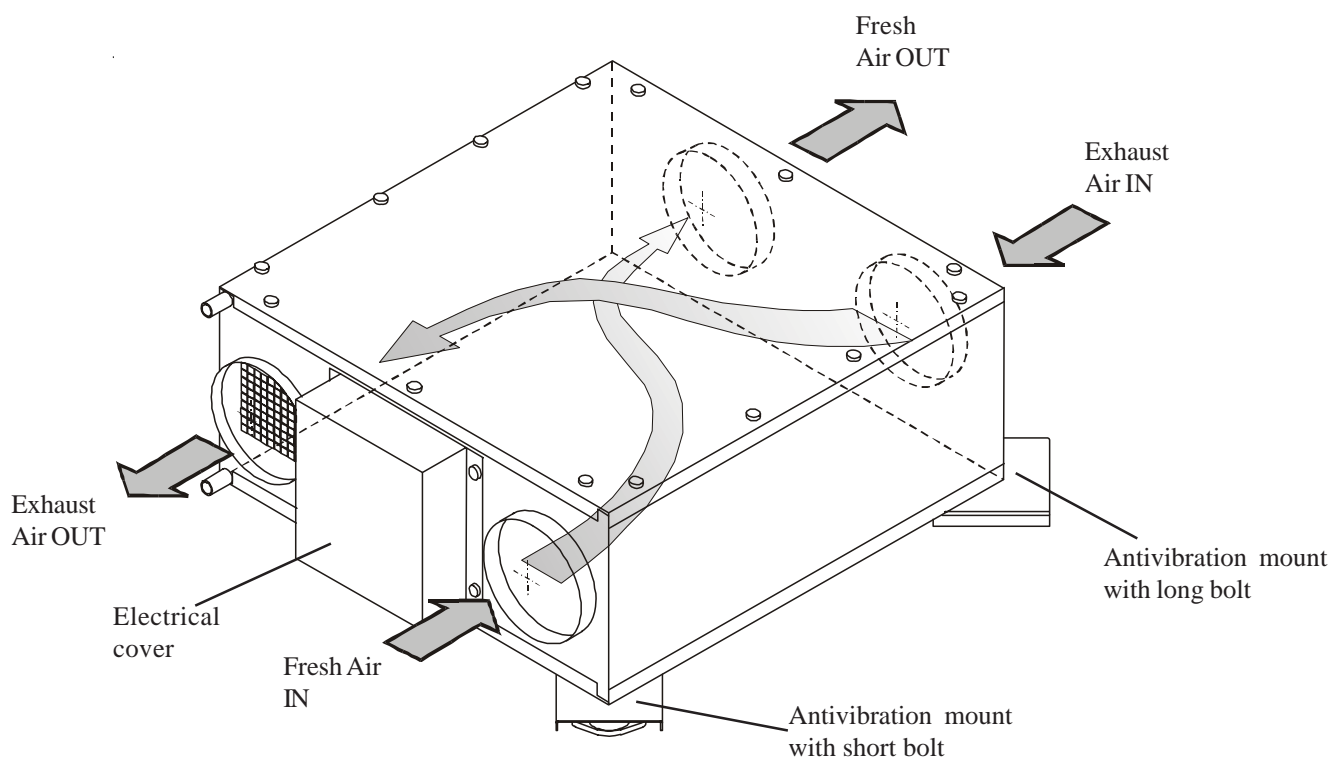

**Fig. 1**  
**HR 100/200 Mk 3**

- 1.2 Installation shall be in accordance with the following:  
 Building Standards (Scotland) (Consolidation) Regulations.  
 Building Regulations.  
 Institute of Electrical Engineering (I.E.E) Regulations.  
**Note:** In order to conform to the above regulations, it may be necessary to fit fire dampers or other suitable devices.
- 1.3 The Design, Material and Installation must only be carried out by competent heating and ventilation engineers.  
**NOTE:** When either unit is linked with a Johnson & Starley warm air heater, the Installation, Commissioning and Servicing Instructions for that appliance are to be read prior to commencement of the installation.

## INSTALLATION

2.

**IMPORTANT:** Ensure that flue gasses from fuel-burning equipment are not drawn into a living area. If any room from which air is extracted contains a fuel burning appliance, such as a central heating boiler, then its flue must be of the room sealed or balanced flue type, or allowance must be made for an adequate supply of air into the room.

2.1 **POSITIONING:** (Refer to the design drawing)

- 2.1.1 The unit should ideally be installed in the roof space, or, if this is not practical, in a heated area such as the false ceiling of a WC.
- 2.1.2 Where possible, the unit should not be installed so that it is directly above a bedroom, living room, or in an area that is part of a living area or bedroom.
- 2.1.3 Consideration must be given to access for servicing, as servicing of the fans and cleaning of the heat exchanger must be carried out annually.

2.2 **MOUNTING:** The unit is supplied with three anti-vibration mountings to provide noise attenuation, and to ensure a downward slope towards the condensate drain. Of the three anti-vibration mountings, 2 are provided with short bolts, and the third is provided with a longer bolt. The anti-vibration mountings are to be fitted as follows:

- 2.2.1 Place the unit on the floor with its base uppermost.
- 2.2.2 Remove the Pozidrive screws from the corners marked 'Exhaust Air In', 'Fresh Air In' and 'Fresh Air Out'.
- 2.2.3 Place the anti-vibration mounting with the longer bolt on the corner marked 'Exhaust Air In' and secure with the 2 x Pozidrive screws previously removed, and ensuring the rubber foot is uppermost.
- 2.2.4 Place the anti-vibration mountings with the short bolts on the corners marked 'Fresh Air In' and 'Fresh Air Out' and secure each with the 2 x Pozidrive screws previously removed, and ensuring the rubber foot is uppermost.
- 2.2.5 Position the unit on its rubber mounting feet in the desired location and secure with suitable screws (not provided), ensuring that there is a defined slope towards the condensate drain.

2.3 **Duct and duct connections,** (refer to design drawing)

- 2.3.1 Four 150mm nominal diameter spigots are provided for the connection of the ducting. These are clearly marked for correct connection of the supply and exhaust ducts. Flexible duct fits over the spigots, whilst rigid duct fits into the spigots.
- 2.3.2 In applications where there are more than two extract points, a collector box should be connected to the unit with a short length of flexible duct.
- 2.3.3 Where ducts are exposed in unheated areas, they should be insulated, except for the exhaust duct from the unit to atmosphere.
- 2.3.4 The duct layout must be designed to suit the requirements of the ventilation/recovery system and building layout, and the protection of fire being transmitted through the ducting by means of suitable fire dampers.
- 2.3.5 Where rigid duct is used, it should be installed using the least number of fittings to minimise the air flow resistance. Where possible, final connection to the grilles and the unit should be made with a flexible connection.
- 2.3.6 Where flexible ducts are used, ensure that:
  - a. Lengths of ducting longer than necessary are not used.
  - b. The duct is stretched so that it is smooth and straight.
  - c. Where bends are necessary, they have large radii - avoid sharp bends.
  - d. Where duct is run in restricted areas, the duct is not crushed.
- 2.3.7 The inlet for the fresh air supply can be direct from outside, or from within a ventilated roof space. If the supply is direct from outside, it must have an external wall baffle fitted if supplied through a wall, or a recognised roof terminal if supplied through a roof. If the supply is from a ventilated roof space, it must be protected by a Johnson & Starley Filter Box (FB100).
- 2.3.8 When the unit is linked with a Johnson & Starley warm air heater, the pre-heated fresh air duct must be run in 150mm dia., and connected to the return air plenum.
- 2.3.9 Kitchen extracts must be filtered.

2.4 **CONDENSATE:** The unit may sometimes produce condensate which must be drained away. A 15mm diameter pipe is provided on the unit.

- 2.4.1 A 15mm diameter pipe must be connected to the pipe connection.
- 2.4.2 The pipe must be installed with a regular downward slope to assist the flow.
- 2.4.3 The pipe must terminate outside the building and drain into the normal drainage system. This can be done in the same fashion as overflow from a domestic cold water storage tank.

- 2.4.4 As stated in Section 2.2, the unit must be tilted towards the corner carrying the condensate exit point.
- 2.4.5 Two condensate drain points are provided, which allow the installer to turn the unit through 180°, to simplify duct layout and connections.

2.5 **ELECTRICAL:** (refer to Fig. 3)

**WARNING: THESE APPLIANCES MUST BE EARTHED, AND ALL WIRING MUST BE TO CURRENT I.E.E. REGULATIONS.**

- 2.5.1 The unit is suitable for a 230V, 50Hz single phase supply fused at 3A.
- 2.5.2 The unit is provided with a terminal strip for connection of the electrical supply cable. The terminals are clearly marked 'LIVE', 'NEUTRAL' and 'EARTH'.
- 2.5.3 The electrical cable must be 1.5mm<sup>2</sup> twin and earth, E.C.C.6242Y to BS 6004, clipped and wired in accordance with I.E.E. regulations (current edition).
- 2.5.4 A fused spur box, or double pole switch having a minimum contact separation of 3mm, must be used for isolation of the unit.
- 2.5.5 Fan speed is controlled by the JS6 fan speed control switch (supplied loose and purpose made to fit a standard single gang deep socket outlet box, see Fig. 2)
- 2.5.6 Location for the JS6 switch is remote from the unit, and the control is ideally suited for location in the kitchen adjacent to the cooker.
- 2.5.7 The cable from the fused spur to the unit, and from the JS6 switch to the unit must be flat twin and earth as detailed in Section 2.5.3

2.6 **INSTALLATION NOTES FOR JS6 FAN SPEED SWITCH:**

- 2.6.1 If the JS6 switch is to be secured to a plastic mounting box, the design of the box must totally enclose the fixing screws and thus prevent them from contacting functional insulation.
- 2.6.2 The JS6 switch must not be mounted above, or closer than 1m to, the cooker where it could be affected by excessive heat and/or moisture.
- 2.6.3 If the JS6 switch is to be fitted into a surface mounted control box, the box must not be mounted on a conductive unearthed metal panel or decorative tile and must include a suitable earth terminal for terminating the cable.
- 2.6.4 The means of disconnecting the JS6 switch from the supply must have a contact separation of at least 3mm at all poles and be incorporated in the fixed wiring.

2.7 **ANCILLARIES:** The following ancillary items are available:

SA	In line sound attenuator, Pt No 1000-0100250.
FB	In line filter box for fresh air inlet.
CL2S	Time control.
CH	FV15 Cooker Hood (unfanned).

**Note:** Fitting instructions are packed separately with each item.

**3. COMMISSIONING**

- 3.1 The units operate by extracting hot stale air from kitchens, WCs, bathrooms etc., and passing it into a heat exchanger and out to atmosphere. Another fan draws in cool fresh air and passes it through the same heat exchanger, where it picks up heat from the outgoing stale air.
- 3.2 When the unit is set up and running, the minimum setting on the JS6 switch must relate to the designed volume air flow. The volume air flow from minimum to maximum allows the unit to extract a greater volume to cope with any increase in the build up of condensation or foul air, i.e., cooking etc.
- 3.3 Before commencing the commissioning procedure, refer to the design drawing for correct air flows.

**Note:** Extract air and supply air volumes will not always be equal, therefore, when setting up, the extract system should be the datum.

SWITCH POSITIONS		FUNCTION
FAN SPEED	VENTILATION	
Normal	Extract & Supply	Both fans running at normal speed.
Boost	Extract & Supply	Both fans running at full speed.
Normal	Extract Only	INLET fan stopped, EXTRACT fan running at normal speed.
Boost	Extract Only	INLET fan stopped, EXTRACT fan running at full speed.

**Table 1**  
**Switch functions**

### 3.4 COMMISSIONING PROCEDURE:

- 3.4.1 Ensure that the exhaust and supply grilles or valves are open.
- 3.4.2 Turn the electrical supply ON, and set the fan speed control to 'NORMAL'. **Note:** If the fans do not start, refer to the defect diagnosis charts on pages 9 and 10
- 3.4.3 Check the airflows at the grilles or valves, and adjust to suit the design figures by turning the centre of the grille clockwise to decrease the airflow, and anticlockwise to increase the airflow.
- 3.4.4 If the airflow is still not correct (the unit is factory set at 100V) proceed as follows:
- Turn the electrical supply OFF,
  - Remove the electrical cover.
  - Locate the 'Voltage Selector' (refer to Fig. 2) and transfer the flying lead to the next connection on the terminal block,
  - Refit the electrical cover panel,
  - Turn the electrical supply ON.
- 3.4.5 Re-measure the airflows at the grilles or valves as detailed in para 5.3.3, and repeat the procedure until the correct airflows are achieved.
- 3.4.6 Set the fan speed control to 'BOOST' and ensure that the airflows increase.
- 3.4.7 If the unit is installed with a Johnson & Starley warm air heater, the airflow is to be set by taking measurements at the extract grilles or valves.

## 4. SERVICING

**IMPORTANT: Before commencing any servicing, ensure the electrical supply to the unit is isolated.**

- 4.1 **ROUTINE MAINTENANCE:** Cleaning of the extract and supply fans, and heat exchanger is required annually. Filters on cooker hoods, or kitchen extract may require cleaning more frequently (see User Instructions).
- 4.2 **FANASSEMBLIES :**
- Remove the 15 x screws securing the lid, and raise the lid approximately 150mm and disconnect the earth wire. Remove the lid, taking care to avoid causing damage to the gasket.
  - Disconnect the electrical connections to the fans.
  - Remove the 4 x screws securing each fan and withdraw each fan. **Note:** It will be necessary to rotate the supply air fan through 90° before it can be removed.
  - Remove all dust etc., from both the impellers and the motors, taking care to avoid disturbing the balance of the fans.
  - Refitment or replacement is in reverse order.

**4.3 HEATEXCHANGER:**

- 4.3.1 Remove the 15 x screws securing the lid, and raise the lid approximately 150mm and disconnect the earth wire. Remove the lid, taking care to avoid causing damage to the gasket.
- 4.3.2 Remove the 8 x screws securing the heat exchanger locating runners, and carefully withdraw the heat exchanger.
- 4.3.3 Check that all the air passages are free from obstruction. If not, clean out by washing in a soapy solution, or with a light brush.**Note:** Under no circumstance must any sharp implements, that are likely to distort or perforate the air passage walls, be used.
- 4.3.4 Refitment or replacement is in reverse order, adjusting the locating runners to ensure that each corner is sealed.

**4.4 SYSTEMMAINTENANCE:**

- 4.4.1 Clean any in line filter that may be installed - see note with filter for instructions.
- 4.4.2 Clean the filter in the kitchen extract grille, if fitted, by washing in a soap solution.
- 4.4.3 Clean the filter in the cooker hood, if fitted, see note with the cooker hood for instructions.

**4.5 CONTROLS CHECK:**

- 4.5.1 Switch on the electrical supply and check that both fans operate.**Note:** If the fans fail to operate, there may be a fault in either the JS6 switch or the power supply from the transformer. In which case, you should proceed to replace as detailed in sections 4.6 or 4.7.
- 4.5.2 Turn JS6 switch to “BOOST” and check that fan speeds increase.
- 4.5.3 Turn JS6 switch to “EXTRACT ONLY” and check that the fresh air intake fan stops.

**4.6 JS6 SWITCH REPLACEMENT:**

- 4.6.1 Remove the JS6 switch (2 x fixing screws).
- 4.6.2 Disconnect the leads at the rear of the switch.
- 4.6.3 Replacement is in reverse order.

**4.7 TRANSFORMER REPLACEMENT:**

- 4.7.1 Remove the front panel and electrical cover.
- 4.7.2 Disconnect the transformer conductors from the electrical panel terminal block, noting their position for re-connection.
- 4.7.3 Release the 2 x screws and washers securing the transformer and remove.
- 4.7.4 Replacement is in reverse order.

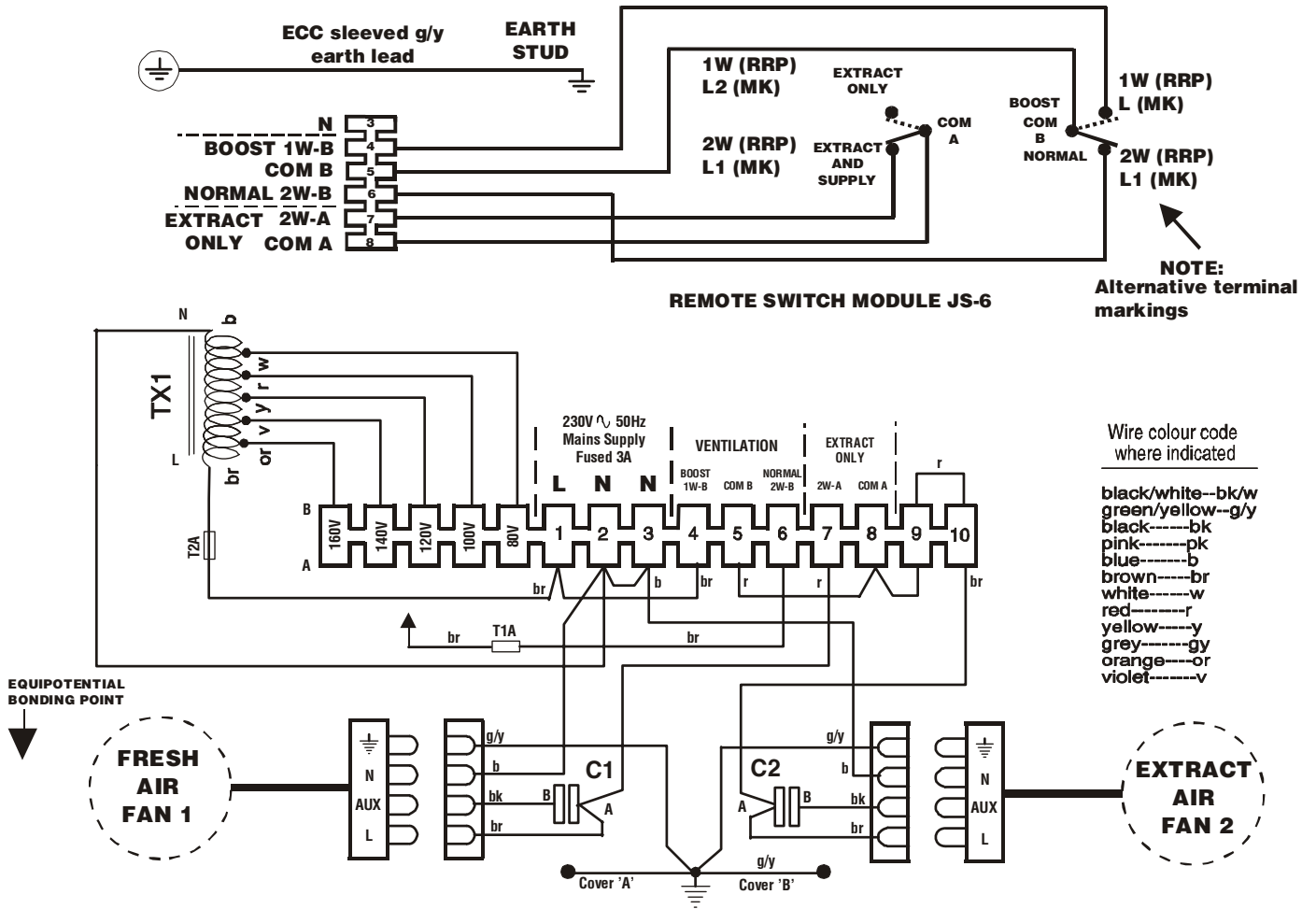
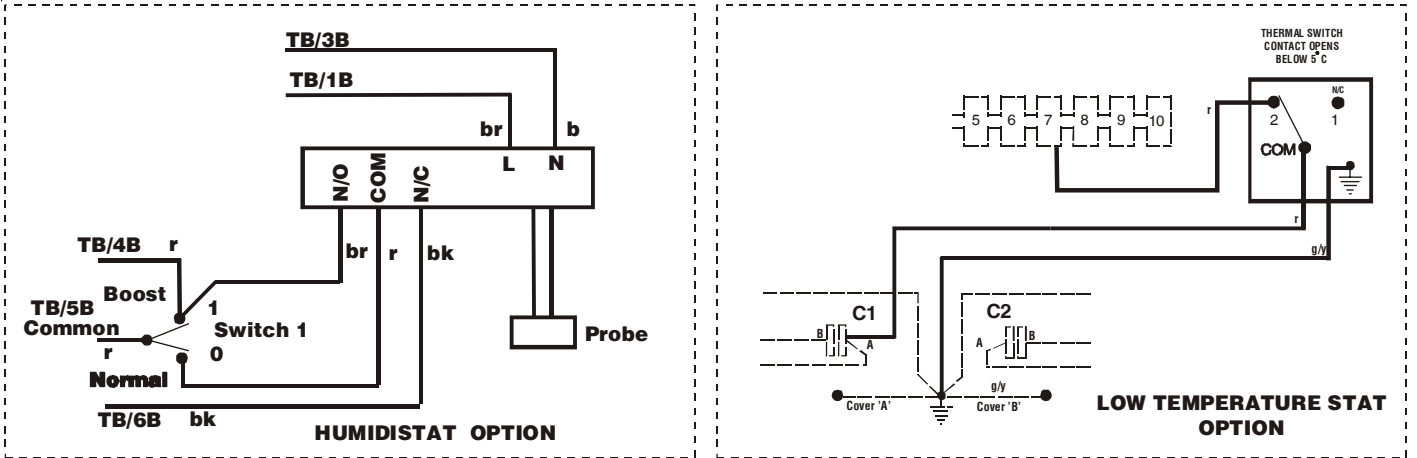
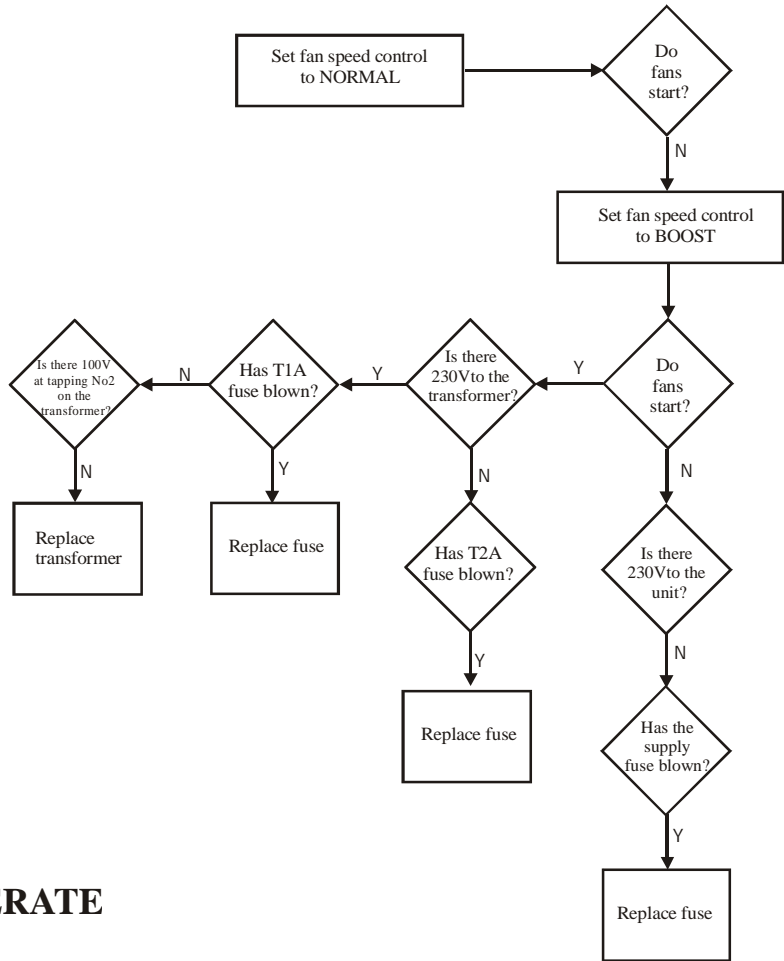

Fig. 2  
Wiring diagram

5.

**FAULT DIAGNOSIS**

**BOTH FANS NOT OPERATING**



**ONE FAN FAILS TO OPERATE**

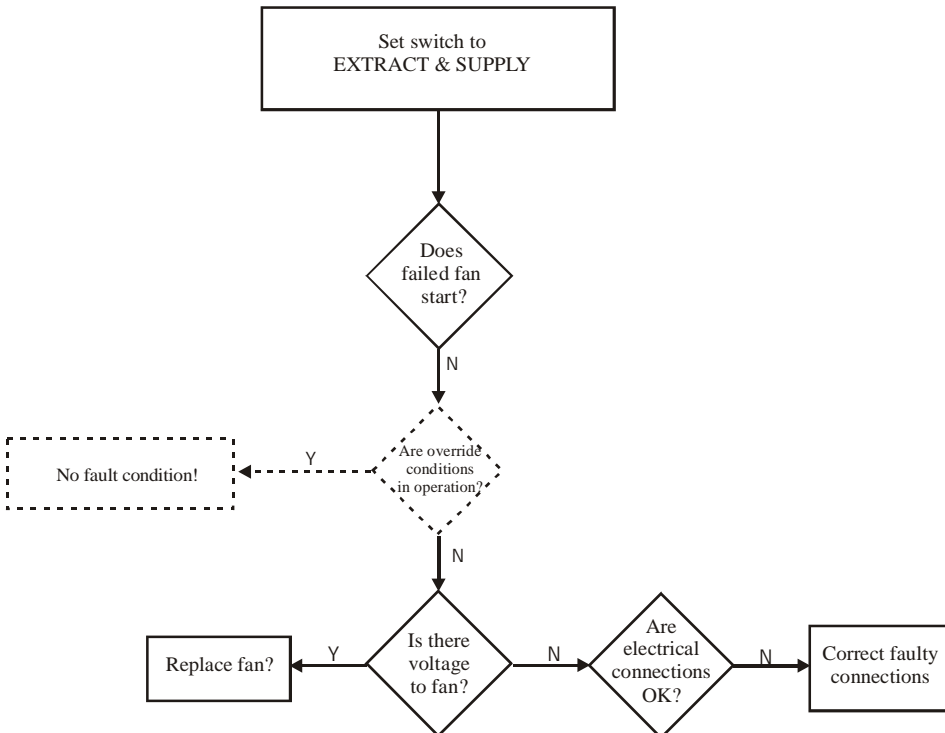

5.

**SPARES LISTING**

<b>Item</b>	<b>Part No</b>	<b>Description</b>	<b>Qty</b>	<b>Appliance</b>
1	HR12-0118000	Air Circulating Fan with integral motor (supply and extract)	2	HR100 Mk3
2	HR22-0118000	Air Circulating Fan with integral motor (supply and extract)	2	HR200 Mk3
3	1000-0300040	Heat Exchanger 200 x 200 x 200	1	HR100 Mk3
4	1000-0300080	Heat Exchanger 300 x 300 x 300	1	HR200 Mk3
5	JS6	Switch	1	Both Mk3
6	1000-2500460	Gasket for case cover	2	HR100 Mk3
7	1000-2500450	Gasket for case cover	2	HR200 Mk3
8	HR10-0129000	Case cover	2	HR100 Mk3
9	HR20-0119000	Case cover	2	HR200 Mk3
10	1000-0506480	Transformer	1	Both Mk3
11	1000-0504690	Capacitor 2.5 $\mu$ F	2	HR100 Mk3
12	1000-0504710	Capacitor 4 $\mu$ F	2	HR200 Mk3
13	1000-0513830	Fuse (T2A)	1	Both Mk3
14	1000-0521690	Thermostat control (if fitted)	1	Both Mk3

Johnson and Starley prides itself on its ability to supply spare parts quickly and efficiently. If your service engineer indicates a problem in obtaining a spare part, advise him to contact Johnson and Starley Spares Department at the address below.

Telephone: 01604 762881

JOHNSON AND STARLEY Ltd.,  
Rhosili Road,  
Brackmills,  
Northampton NN4 7LZ

Fax: 01604 767408