



Leave these instructions with the User or with the appliance

JANUS 6/30, ELJAN 6 and HIJAN 6 GAS FIRED WATER HEATERS USER'S INSTRUCTIONS

Publication No. ZZ 780/3
January 1998

IMPORTANT: STATUTE LAW DEFINES THAT ALL GAS APPLIANCES MUST BE INSTALLED AND MAINTAINED BY COMPETENT PERSONS, (i.e. CORGI REGISTERED INSTALLERS) IN ACCORDANCE WITH THE GAS SAFETY (INSTALLATION AND USE) REGULATIONS (CURRENT EDITION). FAILURE TO COMPLY WITH THESE REGULATIONS MAY LEAD TO PROSECUTION.

THESE APPLIANCES HAVE BEEN TESTED AND CERTIFIED FOR USE WITH NATURAL GAS.

WARNING: ELJAN 6 AND HIJAN 6 APPLIANCES MUST BE EARTHED.

JANUS 6/30, ELJAN 6 and HIJAN 6, are all gas fired appliances which provide domestic hot water and/or space heating when installed in a Johnson and Starley air heater or in a free standing application in the case of the JANUS 6/30. The water temperature is controlled automatically by an integral thermostat in the appliance. In addition, ELJAN 6 and HIJAN 6 can be electrically switched.

JANUS 6/30

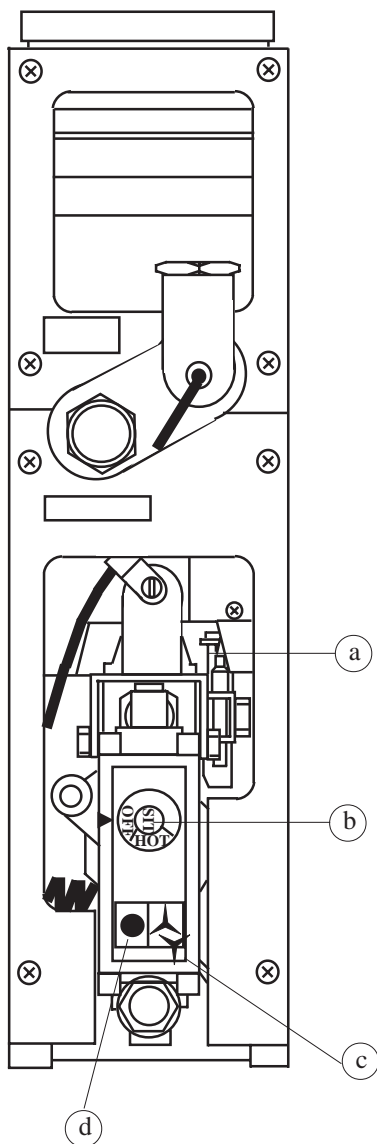

Key	Description
a	Pilot burner
b	Temperature Control Knob
c	START Button
d	OFF Button

ELJAN 6/HIJAN 6

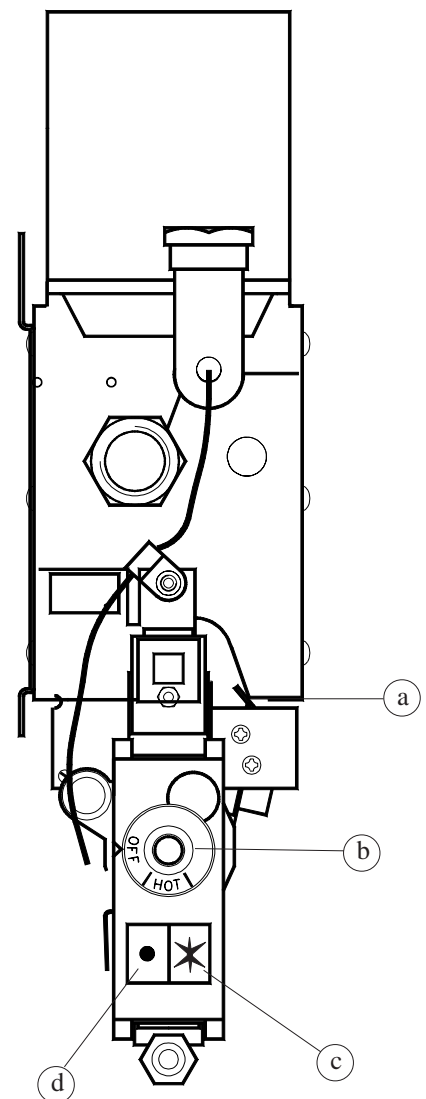

1. TO LIGHT YOUR APPLIANCE

WARNING: If the pilot light is extinguished either intentionally or otherwise, no attempt should be made to relight the gas until at least 3 minutes have elapsed.

- 1.1 Where applicable, remove the bottom door of the air heater.
- 1.2 Check that the system is filled with water.
- 1.3 Ensure the gas, and where applicable the electrical supplies to the air heater and water heater are turned on.
- 1.4 Ensure the Temperature Control Knob is set to 'OFF' (fully clockwise).
- 1.5 Identify the positions of the 'START' button, (on the gas control, marked by a spark symbol,) 'IGNITION' button, and the pilot burner (situated to the right hand side of the main burner).
- 1.6 Press and hold the 'START' button fully in and whilst observing the pilot burner situated on the right of the main burner assembly, repeatedly press and release the 'IGNITION' button until the pilot lights. When the pilot has been lit, keep the 'START' button pressed for a further 20 seconds and then release. The pilot burner should now remain alight. If it does not, press the 'OFF' button and wait until a minimum of three minutes and then repeat the ignition sequence, holding the 'START' in for a little longer than before.

NOTE: When lighting the pilot, ensure that the 'OFF' button is not touched. Partial depression of the 'OFF' button may operate the safety mechanism and prevent the main burner from lighting.

- 1.7 With the pilot burner lit, turn the 'TEMPERATURE CONTROL KNOB' fully anticlockwise. The heater will now operate automatically, controlled by the water thermostat, providing that any switch (time clock or manual control) controlling the system is ON.

2. OPERATION OF YOUR APPLIANCE

- 2.1 The Temperature Control Knob will, in its fully anti clockwise position, control water to the highest temperature. If a lower temperature is required, turn the Temperature Control Knob clockwise to the desired position.

NOTE: If the Temperature Control Knob is removed for any reason, ensure that it is correctly located when refitting. DO NOT USE FORCE or damage will occur. Check the location of the control knob by turning it fully clockwise; OFF shall be against the red marker on the gas control.

- 2.2 The pilot burner must be alight to allow the main burner to operate under automatic control. Should it become extinguished, a safety device will shut off all gas to the appliance.

2.3 TO STOP THE APPLIANCE:

- (a) **For short periods:** Turn the temperature Control Knob to the 'OFF' position and where applicable turn of the electrical supply to the water heater. This will leave the pilot burner lit, but prevent the main burner from lighting.
- (b) **For longer periods:** Press the 'OFF' button and turn the gas supply, and where applicable the electrical supply, to the water heater OFF.

NOTE: In the interest of economy, the hot water cylinder and pipes should be efficiently lagged to minimise heat loss, and water taps should not drip. The water must be drained out of the appliance if it is to be shut off for long periods, and frost damage is a possibility.

3. MAINTENANCE AND GAS TARIFF

It is recommended that a full maintenance check on your appliance is made annually, and that a service contract is taken out on completion of the guarantee period. Your installer will give you details of arrangements for this service. If your installer has difficulty in providing this information, please contact Johnson and Starley Service Department, who will provide information of suitable service companies.

4. IF YOUR APPLIANCE IS NOT GIVING THE SERVICE YOU NEED

- 4.1 Check that the pilot burner is lit. If not, follow the ignition procedure. Should the appliance still fail to function correctly, contact your installer or local gas service engineer.
- 4.2 **New appliances:** Service is supplied under guarantee by the installer for the first 12 months, thereafter, should you have difficulty in obtaining service, contact Johnson and Starley Service Department, who will provide information of suitable service companies.

4.3 For your appliance to operate safely and efficiently, it is ESSENTIAL to OBSERVE THE FOLLOWING:

- 4.3.1 If the appliance has been installed in a cupboard, **DO NOT BLOCK** any **GRILLES** provided in the cupboard door(s).
- 4.3.2 **DO NOT PLACE** anything (clothing, linen, etc.) in contact with the appliance or its flue pipe.
- 4.3.3 **DO NOT USE** the heater compartment for storage or airing.

IF YOU SMELL GAS: (i) TURN OFF the gas supply
(ii) VENTILATE the area

(iii) DO NOT operate any electrical switches
(iv) CONTACT your installer or local gas service engineer

Johnson and Starley prides itself on its ability to supply spare parts quickly and efficiently. If your service engineer indicates a problem in obtaining a spare part, advise him to contact Johnson and Starley Spares Department at the address below.

Telephone: 01604 762881

JOHNSON AND STARLEY Ltd.,
Rhosili Road,
Brackmills,
Northampton, NN4 7LZ

Fax : 01604 767408