

# U.K. Commercial Instruction Manual For Gas Water Heaters

## NOT FOR USE IN MOBILE HOMES

### MODELS

SBT100-400 NE  
SBT80-500 NE  
SBT80-180 NE  
SBT30-225 NE  
SBT75-300 NE  
SBT75-155 NE  
SBT75-250 NE



GAMA certification applies to all residential gas water heaters with capacities of 20 to 100 gallons with input rating of 75,000 BTU/Hr. or less.

**ALL TECHNICAL AND WARRANTY QUESTIONS:** SHOULD BE DIRECTED TO THE LOCAL DEALER FROM WHOM THE WATER HEATER WAS PURCHASED. IF YOU ARE UNSUCCESSFUL, PLEASE WRITE TO THE COMPANY LISTED ON THE WARRANTY SHEET WHICH CAME WITH THE WATER HEATER.

## For Your Safety **AN ODORANT IS ADDED TO THE GAS USED BY THIS WATER HEATER**

**WARNING:** If the information in these instructions are not followed exactly, a fire or explosion may result, causing property damage, personal injury or death.

-Do not store or use gasoline or other flammable vapors and liquids in the vicinity of this or any other appliance.

### -WHAT TO DO IF YOU SMELL GAS

- Do not try to light any appliance.
- Do not touch any electrical switch; do not use any phone in your building.
- Immediately call your gas supplier from a neighbor's phone. Follow the gas supplier's instructions.
- If you can not reach your gas supplier, call the fire department.

-Installation and service must be performed by a qualified installer, service agency or the gas supplier.

### WARNING

Improper installation, adjustment, alteration, service or maintenance can cause **DEATH, SERIOUS BODILY INJURY OR PROPERTY DAMAGE.** Refer to this manual for assistance or consult the local gas utility for further information.

### WARNING

Flammable vapors may be drawn by air currents from other areas of the structure to this appliance.

### WARNING

**READ THE GENERAL SAFETY SECTION BEGINNING ON INSIDE COVER AND THEN THIS ENTIRE MANUAL BEFORE INSTALLING OR OPERATING THIS WATER HEATER.**

# General Safety

## WARNING

Improper installation, adjustment, alteration, service or maintenance can cause DEATH, SERIOUS BODILY INJURY OR PROPERTY DAMAGE. Refer to this manual for assistance or consult your local gas utility and/or plumbing contractor.

## WARNING

At the time of manufacture this water heater was provided with a combination temperature-pressure relief valve certified by a nationally recognized testing laboratory that maintains periodic inspection of production of listed equipment or materials, as meeting the requirements for Relief Valves and Automatic Gas Shutoff Devices for Hot Water Supply Systems, and the latest edition of ANSI Z21.22 and the code requirements of ASME. If replaced, the valve must meet the requirements of local codes, but not less than a combination temperature and pressure relief valve certified as meeting the requirements for Relief Valves and Automatic Gas Shutoff Devices for Hot Water Supply Systems, ANSI Z21.22 by a nationally recognized testing laboratory that maintains periodic inspection of production of listed equipment or materials.

The valve must be marked with a maximum set pressure not to exceed the marked hydrostatic working pressure of the water heater (150 lbs./sq. in.) and a discharge capacity not less than the water heater input rate as shown on the model rating plate. (Electric heaters - watts divided by 1000 x 3415 equal BTU/Hr. rate.)

Your local jurisdictional authority, while mandating the use of a temperature-pressure relief valve complying with ANSI Z21.22 and ASME, may require a valve model different from the one furnished with the water heater.

Compliance with such local requirements must be satisfied by the installer or end user of the water heater with a locally prescribed temperature-pressure relief valve installed in the designated opening in the water heater in place of the factory furnished valve.

For safe operation of the water heater, the relief valve must not be removed from its designated opening or plugged.

The temperature-pressure relief valve must be installed directly into the fitting of the water heater designated for the relief valve. Position the valve downward and provide tubing so that any discharge will exit only within 6 inches above, or at any distance below the structural floor. Be certain that no contact is made with any live electrical part. The discharge opening must not be blocked or reduced in size under any circumstances. Excessive length, over 30 feet, or use of more than four elbows can cause restriction and reduce the discharge capacity of the valve.

No valve or other obstruction is to be placed between the relief valve and the tank. Do not connect tubing directly to discharge drain unless a 6" air gap is provided. To prevent bodily injury, hazard to life, or property damage, the relief valve must be allowed to discharge water in quantities should circumstances demand. If the discharge pipe is not connected to a drain or other suitable means, the water flow may cause property damage.

### The Discharge Pipe:

- Must not be smaller in size than the outlet pipe size of the valve, or have any reducing couplings or other restrictions.
- Must not be plugged or blocked.
- Must be of material listed for hot water distribution.
- Must be installed so as to allow complete drainage of both the temperature-pressure relief valve, and the discharge pipe.
- Must terminate at an adequate drain.
- Must not have any valve between the relief valve and tank.

## WARNING

**WATER HEATERS EQUIPPED FOR ONE TYPE GAS ONLY:** This water heater is equipped for one type gas only. Check the model rating plate near the gas control valve for the correct gas. **DO NOT USE THIS WATER HEATER WITH ANY GAS OTHER THAN THE ONE SHOWN ON THE MODEL RATING PLATE.** Failure to use the correct gas can cause problems which can result in DEATH, SERIOUS BODILY INJURY, OR PROPERTY DAMAGE. If you have any questions or doubts consult your gas supplier or local utility.

## WARNING

A fire can start if combustible materials such as clothing, cleaning materials, or flammable liquids are placed against or next to the water heater.

## WARNING

**INSTALLATIONS IN AREAS WHERE FLAMMABLE LIQUIDS (VAPORS) ARE LIKELY TO BE PRESENT OR STORED (GARAGES, STORAGE, AND UTILITY AREAS, ETC.):** Flammable liquids (such as gasoline, solvents, propane (LP) or butane, etc.), all of which emit flammable vapors, may be improperly stored or used in such areas. The gas water heater pilot light or main burner can ignite such vapors. The resulting flashback and fire can cause death or serious burns to anyone in the area, as well as property damage.

If installation in such areas is your only option, then the installation must be accomplished in a way that the pilot flame and main burner flame are elevated from the floor at least 18 inches. While this may reduce the chances of flammable vapors from a floor spill being ignited, gasoline and other flammable substances should never be stored or used in the same room or area containing a gas water heater or other open flame or spark producing appliance.

**NOTE:** Flammable vapors may be drawn by air currents from other areas of the structure to the appliance.

## WARNING

**HOTTER WATER CAN SCALD:** Water heaters are intended to produce hot water. Water heated to a temperature which will satisfy clothes washing, dish washing, and other sanitizing needs can scald and permanently injure you upon contact. Some people are more likely to be permanently injured by hot water than others. These include the elderly, children, the infirm, or physically/mentally handicapped. If anyone using hot water in your home fits into one of these groups or if there is a local code or state law requiring a certain temperature water at the hot water tap, then you must take special precautions. In addition to using the lowest possible temperature setting that satisfies your hot water needs, a means such as a mixing valve, should be used at the hot water taps used by these people or at the water heater. Mixing valves are available at plumbing supply or hardware stores. Follow manufacturers instructions for installation of the valves. Before changing the factory setting on the thermostat, read the "Temperature Regulation" section in this manual.

## WARNING

**BEFORE LIGHTING [PROPANE (L.P.) GAS WATER HEATERS]:** Propane (L.P.) gas is heavier than air. Should there be a leak in the system, the gas will settle near the ground. Basements, crawl spaces, skirted areas under mobile homes (even when ventilated), closets and areas below ground level will serve as pockets for the accumulation of this gas. Before attempting to light or relight the water heater's pilot or turning on a nearby electrical light switch, be absolutely sure there is no accumulated gas in the area. Search for odor of gas by sniffing at ground level in the vicinity of the appliance. If odor is detected, follow steps indicated at "For Your Safety" on the cover page of this manual then leave the premises.

# General Safety (cont'd)

## WARNING

This water heater must not be installed directly on carpeting. Carpeting must be protected by a metal or wood panel beneath the appliance extending beyond the full width and depth of the appliance by at least 3 inches (76.2mm) in any direction, or if the appliance is installed in an alcove or closet, the entire floor must be covered by the panel. Failure to heed this warning may result in a fire hazard.

## WARNING

A gas water heater cannot operate properly without the correct amount of air for combustion. Never obstruct the flow of ventilation air. If you have any doubts or questions at all, call your gas company. Failure to provide the proper amount of combustion air can result in a fire or explosion and can cause DEATH, SERIOUS BODILY INJURY, OR PROPERTY DAMAGE.

## WARNING

If this water heater will be used in beauty shops, barber shops, cleaning establishments, or self-service laundries with dry cleaning equipment, it is imperative that the water heater or water heaters be installed so that combustion and ventilation air be taken from outside these areas. Refer to the "Combustion and Ventilation Air Supply" section.

## WARNING

**VENT DAMPERS** - Any vent damper, whether it is operated thermally or otherwise must be removed if its use inhibits proper drafting of the water heater.

**Thermally Operated Vent Dampers:** Gas-fired water heaters having thermal efficiency in excess of 80% may produce a relatively low flue gas temperature. Such temperatures may not be high enough to properly open thermally operated vent dampers. This would cause spillage of flue gases and may cause carbon monoxide poisoning.

Vent dampers must bear evidence of certification as complying with the latest edition of American National Standard ANSI Z21.68 (ANSI Z21.66 & 67, respectively, cover electrically and mechanically actuated vent dampers). Before installation of any vent damper, consult your local Sears Service Center or the gas utility for further information.

## WARNING

1. The appliance and its individual shutoff valve must be disconnected from the gas supply piping system during any pressure testing of the gas system at test pressures in excess of 1/2 pound per square inch (3.5kPa).

2. The appliance must be isolated from the gas supply piping system by closing its individual manual shutoff valve during any pressure testing of the gas supply piping system at test pressures equal or less than 1/2 pound per square inch (3.5kPa).

## WARNING

Soot build-up indicates a problem that requires correction before further use. Turn "OFF" gas to water heater and leave "OFF" until repairs are made, because failure to correct the cause of the sooting can result in a fire or explosion causing DEATH, SERIOUS BODILY INJURY, OR PROPERTY DAMAGE.

## WARNING

The water heater with draft hood installed must be properly vented to a chimney which terminates outdoors. Never operate the water heater unless it is vented to the outdoors and has adequate air supply to avoid risks of improper operation, explosion or asphyxiation.

## WARNING

Obstructed or deteriorated vent systems may present a serious health risk or asphyxiation.

## WARNING

Chemical vapor corrosion of the flue and vent system may occur if air for combustion contains certain chemical vapors. Spray can propellants, cleaning solvents, refrigerator and air conditioner refrigerants, swimming pool chemicals, calcium and sodium chloride, waxes, bleach, and process chemicals are typical compounds which are potentially corrosive.

## WARNING

Minimum clearances between the water heater and combustible construction are listed below:

All Models - Sides and Rear - 152mm - 6"

All Models - Front - 610mm - 24"

All Models - Above - 1030mm - 40.5"

## WARNING

**HYDROGEN GAS:** Hydrogen gas can be produced in a hot water system that has not been used for a long period of time (generally two weeks or more). Hydrogen gas is extremely flammable and explosive. To prevent the possibility of injury under these conditions, we recommend the hot water faucet be opened for several minutes at the kitchen sink before any electrical appliances which are connected to the hot water system are used (such as a dishwasher or washing machine). If hydrogen gas is present, there will probably be an unusual sound similar to air escaping through the pipe as the hot water faucet is opened. There must be no smoking or open flame near the faucet at the time it is open.

## WARNING

**INSULATING JACKETS:** When installing an external water heater insulation jacket on an gas water heater:

- DO NOT cover the temperature-pressure relief valve.
- DO NOT put insulation over any part of the top of the gas water heater.
- DO NOT put insulation over the gas control valve or gas control valve/burner cover, or any access areas to the burner.
- DO NOT let insulation around the gas water heater to get within 8 inches of the floor (air must get to the burner).
- DO NOT cover or remove operating instructions, and safety related warning labels and materials affixed to the water heater.

Failure to heed this will result in the possibility of a fire or explosion.

## WARNING

Do not use this appliance if any part of it has been under water. Immediately call a qualified service technician to inspect the appliance and to replace the gas control or any part of the burner system which has been under water.

## CAUTION

**WATER HEATERS EVENTUALLY LEAK:** Installation of the water heater must be accomplished in such a manner that if the tank or any connections should leak, the flow of water will not cause damage to the structure. When such locations cannot be avoided, a suitable drain pan should be installed under the water heater. Drain pans are available at your local hardware store. Such a drain pan must be not greater than 1 1/2 inches deep, have a minimum length and width of at least 2 inches greater than the water heater dimensions and must be piped to an adequate drain. The pan must not restrict combustion air flow. Under no circumstances is the manufacturer to be held liable for any water damage in connection with this water heater.

# Table of Contents

<b>General Safety</b> .....	2-3
<b>Table of Contents</b> .....	4
<b>General Description</b> .....	4
<b>Technical Data</b> .....	5-11
<b>Installation</b> .....	12-15
Related Documents .....	12
Location Selection .....	12
Combustion and Ventilation Air Supply .....	12
Effects of an Extract Fan .....	12
Gas Meter .....	13
Gas Piping .....	13
Flue System .....	13
Common Flues .....	14
Water Connections .....	14
Water Treatment .....	15
Temperature and Pressure Relief Valve .....	15
<b>Operation</b> .....	16
Before Operating the Water Heater .....	16
Pilot Burner Adjustment .....	16
Main Burner Air Adjustment .....	16
Operational Sequence - Natural Gas Only .....	16
Safety Sequence - Natural Gas Only .....	17
Compensating Thermostat with Manual E.C.O. ....	17
Water Temperatures .....	17
Burner Inspection .....	17
Burner Cleaning .....	17
Lighting .....	18
Wiring Diagrams .....	19
<b>Replacement of Parts</b> .....	20-21

## General Description

The "Turbo Sandblaster" water heater described in this manual is a floor standing, open flued direct fired storage water heater. Each storage vessel is internally lined with a vitreous enamel coating and is fitted with sacrificial aluminium anode rods to protect against hot water corrosion. The tank is insulated with a layer of fibreglass insulation and is covered by a metal casing finished in a blue stoved enamel paint with a dark blue trim. Each unit is equipped with a stainless steel atmospheric burner, magnesium sacrificial anode rods and a low level drain tap.

# Technical Data

## Technical Data SBT 100-400 NE

Continuous at 80°F 44°C temperature rise	1693 litre/hr	373 UK gal/hr
Storage capacity	379 litres	83 UK gal
Weight filled	773 kg	1700lb
Time to recover storage with 44°C temperature rise	14 minutes	14 minutes
Input rate	10.9m <sup>3</sup> /hr	383 ft <sup>3</sup> /hr
Input gross	117kW	400,000 Btu/hr
Maximum working head	10.3 bar	150 psig.
Minimum working head	3 mtrs	10 ft
Nominal gas inlet pressure (natural gas)	17.5 mbar	7 in wg
Maximum gas inlet pressure	35 mbar	14 in wg
Burner setting pressure	10 mbar	4 in wg
Injector size	2.9mm	—
Approx flue gas	163 m <sup>3</sup> /hr	5745 ft <sup>3</sup> /hr
Approx flue gas temperature	238°C	460°F
Water connections –cold inlet –hot inlet	1½ BSP 1½ BSP	1½ BSP 1½ BSP
Open Vent	25mm	Minimum 1"
Cold feed pipe	19mm	Minimum ¾"
Gas connection	—	1" BSP
Draught diverter outlet size	228mm	9"
Shipping weight	395kg	870lbs
MINIMUM CLEARANCE		
Sides and Rear	152mm	6"
Front	610mm	24"
Above	1030mm	40.5"
Natural Ventilation: Air direct from outside		
High level	263 cm <sup>2</sup>	40"
Low level	526 cm <sup>2</sup>	80"
Safety Valve	19mm	1"
BS759 or BS6759 –Max Rating	11 Bar	160 psi
Electrical Rating	240V - 1 amp or less	

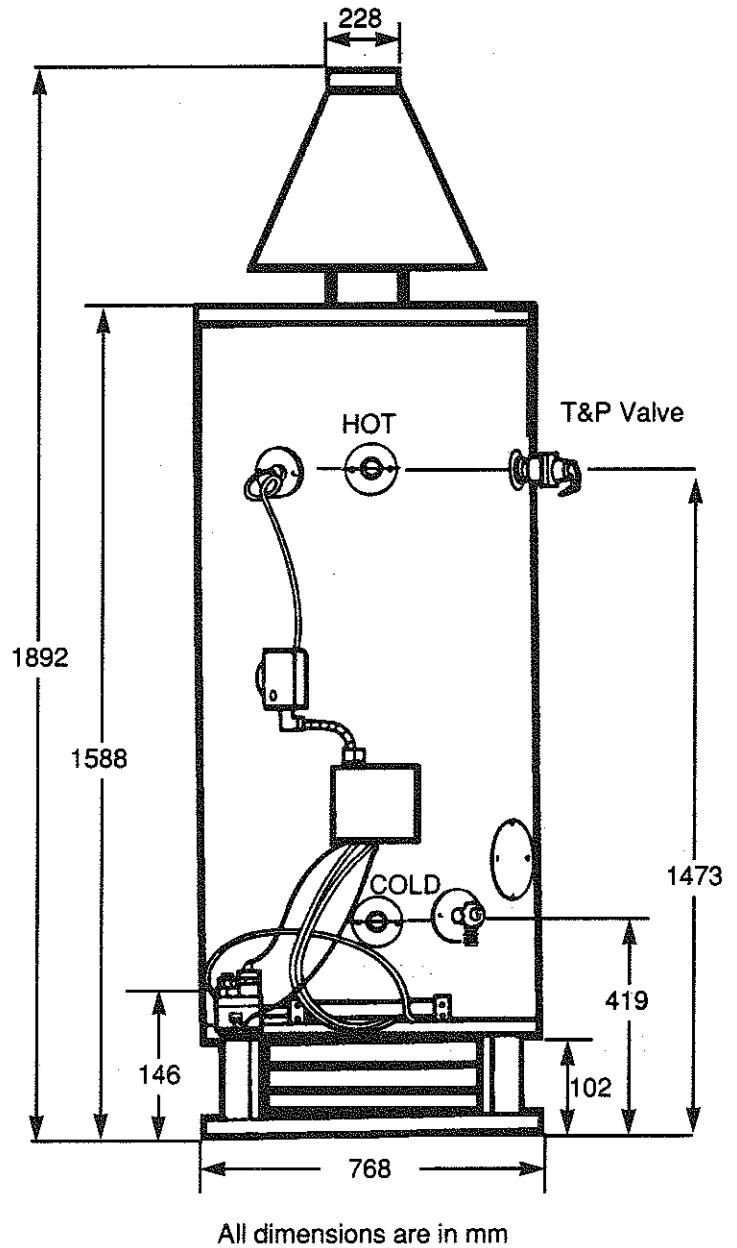

# Technical Data

## Technical Data SBT 80-180 NE

Continuous at 80°F 44°C temperature rise	742 litre/hr	163 UK gal/hr
Storage capacity	303 litres	67 UK gal
Weight filled	595 kg	1310lb
Time to recover storage with 44°C temperature rise	25 minutes	25 minutes
Input rate	4.95m <sup>3</sup> /hr	174 ft <sup>3</sup> /hr
Input gross	53kW	180,000 Btu/hr
Maximum working head	10.3 bar	150 psig.
Minimum working head	3 metres	10 ft
Nominal gas inlet pressure (natural gas)	17.5 mbar	7 in wg
Maximum gas inlet pressure	35 mbar	14 in wg
Burner setting pressure	10.0 mbar	4 in wg
Injector size	2.26mm	–
Approx flue gas	74.25 m <sup>3</sup> /hr	2610 ft <sup>3</sup> /hr
Approx flue gas temperature	238°C	460°F
Water connections–cold inlet –hot inlet	1½ BSP 1½ BSP	1½ BSP 1½ BSP
Open Vent	25mm	Minimum 1"
Cold feed pipe	19mm	Minimum ¾"
Gas connection	–	¼"BSP
Draught diverter outlet size	127mm	5"
Shipping weight	290kg	640lbs
<b>MINIMUM CLEARANCE</b>		
Sides and Rear	152mm	6"
Front	610mm	24"
Above	1030mm	40.5"
Natural Ventilation: Air direct from outside		
High level	119 cm <sup>2</sup>	18 in <sup>2</sup>
Low level	238 cm <sup>2</sup>	36 in <sup>2</sup>
Safety Valve	19mm	¾"
BS759 or BS6759 –Max Rating	11 Bar	160 psi
Electrical Rating	240V - 1 amp or less	

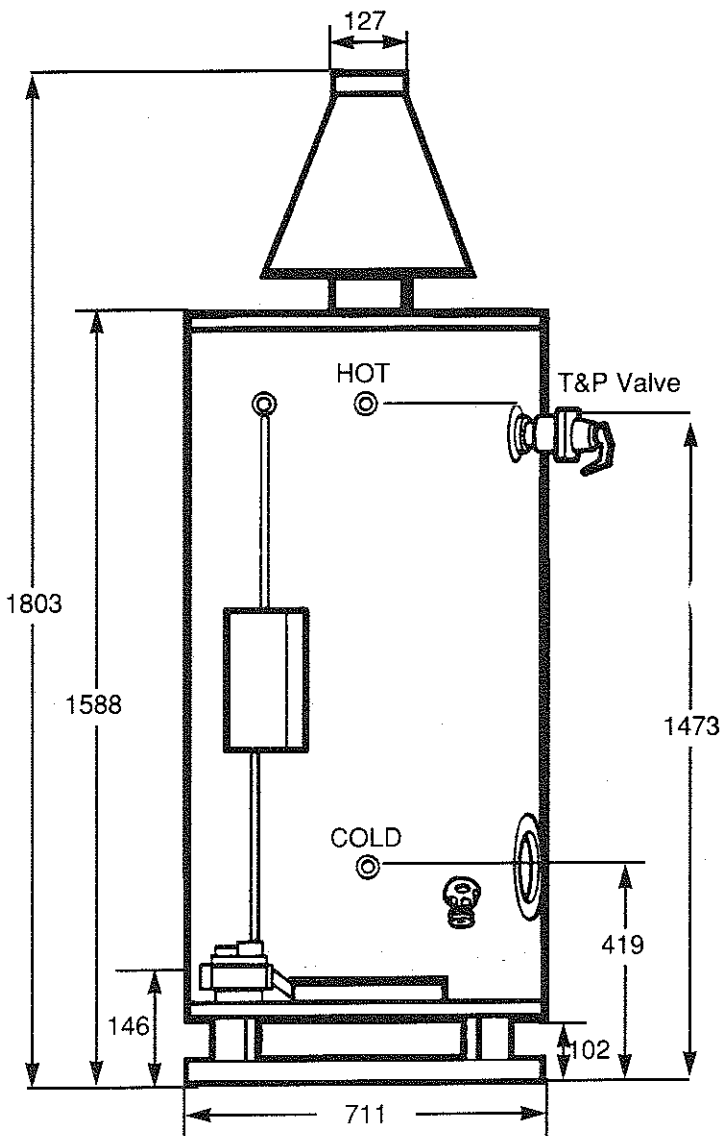

All dimensions are in mm

# Technical Data

## Technical Data SBT 30-225 NE

Continuous at 80°F 44°C temperature rise	946 litre/hr	208 UK gal/hr
Storage capacity	113 litres	25 UK gal
Weight filled	351kg	773lb
Time to recover storage with 44°C temperature rise	7 minutes	7 minutes
Input rate	6.17m <sup>3</sup> /hr	217 ft <sup>3</sup> /hr
Input gross	66kW	225,000 Btu/hr
Maximum working head	10.3 bar	150 psig.
Minimum working head	3 metres	10 ft
Nominal gas inlet pressure (natural gas)	17.5 mbar	7 in wg
Maximum gas inlet pressure	35 mbar	14 in wg
Burner setting pressure	10.0 mbar	4 in wg
Injector size	2.56mm	-
Approx flue gas	92.55 m <sup>3</sup> /hr	3255 ft <sup>3</sup> /hr
Approx flue gas temperature	238°C	460°F
Water connections—cold inlet —hot inlet	1½ BSP 1½ BSP	1½ BSP 1½ BSP
Open Vent	25mm	Minimum 1"
Cold feed pipe	19mm	Minimum ¾"
Gas connection	-	¾" BSP
Draught diverter outlet size	178mm	7"
Shipping weight	238kg	525lbs
MINIMUM CLEARANCE		
Sides and Rear	152mm	6"
Front	610mm	24"
Above	1030mm	40.5"
Natural Ventilation: Air direct from outside		
High level	148 cm <sup>2</sup>	22.5 in <sup>2</sup>
Low level	297 cm <sup>2</sup>	45 in <sup>2</sup>
Safety Valve	19mm	¾"
BS759 or BS6759 —Max Rating	11 Bar	160 psi
Electrical Rating	240V - 1 amp or less	

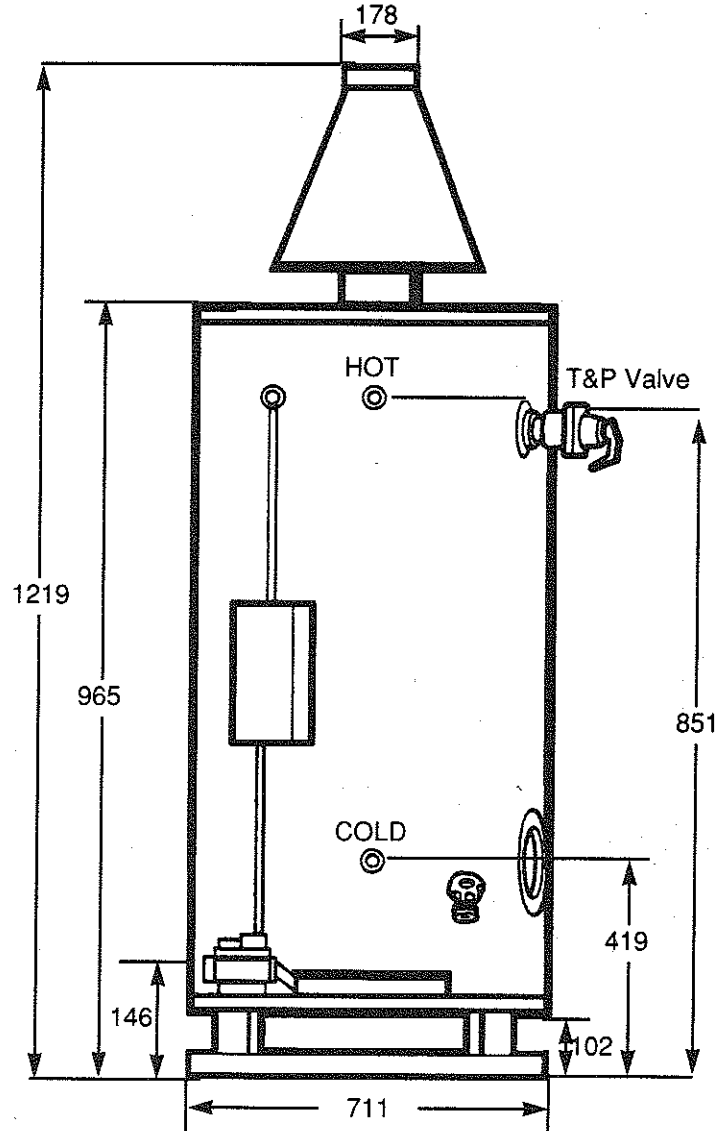

All dimensions are in mm

# Technical Data

## Technical Data SBT 75-300 NE

Continuous at 80°F 44°C temperature rise	1264 litre/hr	278 UK gal/hr
Storage capacity	284 litres	62.5 UK gal
Weight filled	652kg	1435lb
Time to recover storage with 44°C temperature rise	14 minutes	14 minutes
Input rate	8.25m³/hr	390 ft³/hr
Input gross	88kW	300,000 Btu/hr
Maximum working head	10.3 bar	150 psig.
Minimum working head	3 metres	10 ft
Nominal gas inlet pressure (natural gas)	17.5 mbar	7 in wg
Maximum gas inlet pressure	35 mbar	14 in wg
Burner setting pressure	9.2 mbar	3.7 in wg
Injector size	2.94mm	—
Approx flue gas	123.7 m³/hr	4350 ft³/hr
Approx flue gas temperature	238°C	460°F
Water connections—cold inlet —hot inlet	1½ BSP 1½ BSP	1½ BSP 1½ BSP
Open Vent	25mm	Minimum 1"
Cold feed pipe	19mm	Minimum ¾"
Gas connection	—	¾" BSP
Draught diverter outlet size	178mm	7"
Shipping weight	370kg	815lbs
<b>MINIMUM CLEARANCE</b>		
Sides and Rear	152mm	6"
Front	610mm	24"
Above	1030mm	40.5"
<b>Natural Ventilation:</b> Air direct from outside		
High level	198 cm²	30 in²
Low level	396 cm²	60 in²
Safety Valve	19mm	¾"
BS759 or BS6759 —Max Rating	11 Bar	160 psi
Electrical Rating	240V - 1 amp or less	

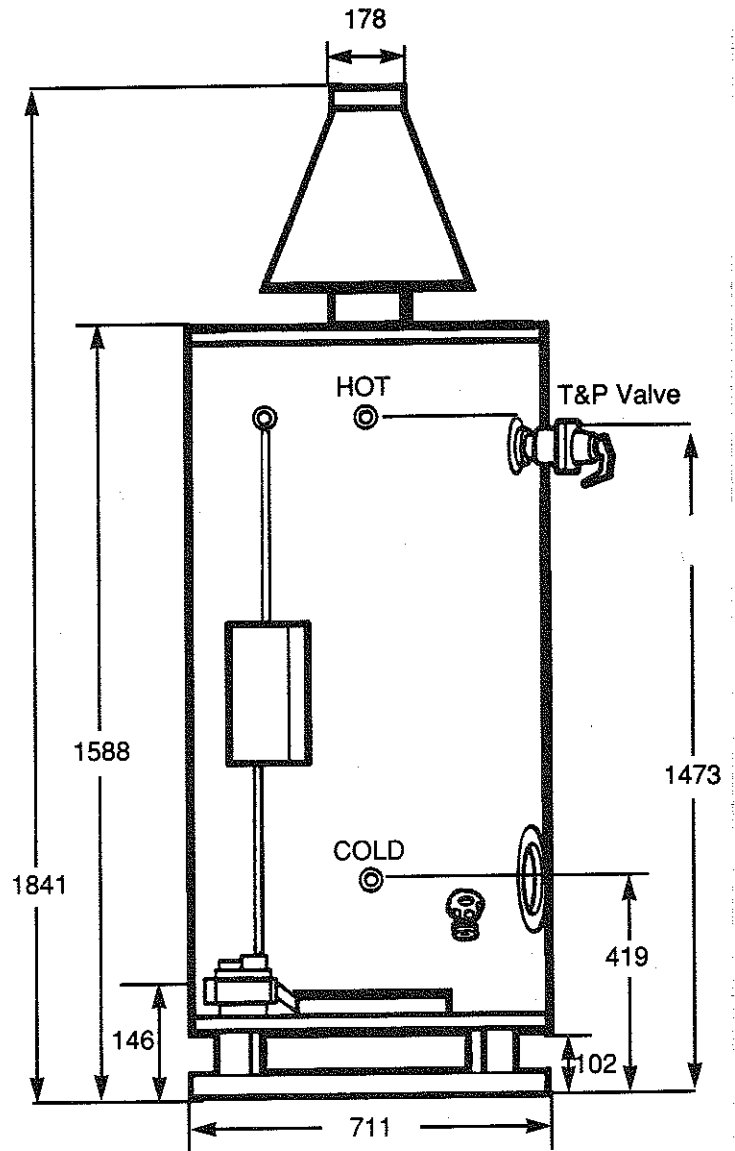

All dimensions are in mm



# Technical Data

## Technical Data SBT 75-250 NE

Continuous at 80°F 44°C temperature rise	1053 litre/hr	232 UK gal/hr
Storage capacity	284 litres	62.5UK gal
Weight filled	652kg	1435lb
Time to recover storage with 44°C temperature rise	17 minutes	17 minutes
Input rate	6.87m <sup>3</sup> /hr	325 ft <sup>3</sup> /hr
Input gross	73kw	250,000 Btu/hr
Maximum working head	10.3 bar	150 psig.
Minimum working head	3 metres	10 ft
Nominal gas inlet pressure (natural gas)	17.5 mbar	7 in wg
Maximum gas inlet pressure	35 mbar	14 in wg
Burner setting pressure	9.2 mbar	3.7 in wg
Injector size	2.6mm	-
Approx flue gas	103.1 m <sup>3</sup> /hr	3625 ft <sup>3</sup> /hr
Approx flue gas temperature	238°F	460°F
Water connections -cold inlet -hot inlet	1½ BSP 1½ BSP	1½ BSP 1½ BSP
Open Vent	25mm	Minimum 1"
Cold feed pipe	19mm	Minimum ¾"
Gas connection	-	¾"BSP
Draught diverter outlet size	-	7"
Shipping weight	370kg	815lbs
MINIMUM CLEARANCE		
Sides and Rear		6"
Front		24"
Above		40.5"
Natural Ventilation: Air direct from outside		
High level	198 cm <sup>2</sup>	30 in <sup>2</sup>
Low level	396 cm <sup>2</sup>	60 in <sup>2</sup>
Safety Valve		¾"
BS759 or BS6759 -Max Rating		160 psi
Electrical Rating	240V - 1 amp or less	

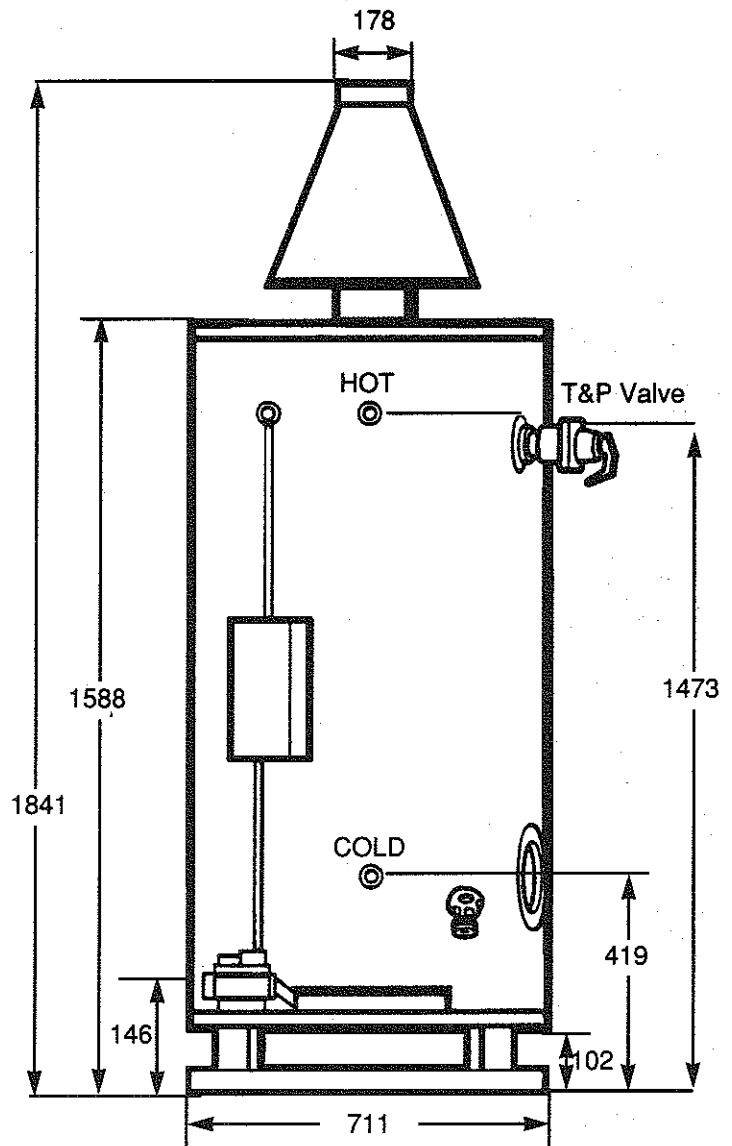

All dimensions are in mm

# Technical Data

## Technical Data SBT 75-155 NE

Continuous at 80°F 44°C temperature rise	653 litre/hr	144 UK gal/hr
Storage capacity	284 litres	62.5UK gal
Weight filled	SA5	1200lb
Time to recover storage with 44°C temperature rise	27 minutes	27 minutes
Input rate	4.26m <sup>3</sup> /hr	201 ft <sup>3</sup> /hr
Input gross	49kw	155,000 Btu/hr
Maximum working head	10.3 bar	150 psig.
Minimum working head	3 metres	10 ft
Nominal gas inlet pressure (natural gas)	17.5 mbar	7 in wg
Maximum gas inlet pressure	35 mbar	14 in wg
Burner setting pressure		3.7 in wg
Injector size	2.45mm	-
Approx flue gas	63.9 m <sup>3</sup> /hr	.2247 ft <sup>3</sup> /hr
Approx flue gas temperature	238°F	460°F
Water connections -cold inlet -hot inlet	1½ BSP 1½ BSP	1½ BSP 1½ BSP
Open Vent	25mm	Minimum 1"
Cold feed pipe	19mm	Minimum ¾"
Gas connection	-	¾"BSP
Draught diverter outlet size	-	5"
Shipping weight	263kg	580lbs
<b>MINIMUM CLEARANCE</b>		
Sides and Rear		6"
Front		24"
Above		4.5"
Natural Ventilation: Air direct from outside		
High level	198 cm <sup>2</sup>	30 in <sup>2</sup>
Low level	396 cm <sup>2</sup>	60 in <sup>2</sup>
Safety Valve		¾"
BS759 or BS6759 -Max Rating		160 psi
Electrical Rating	240V - 1 amp or less	

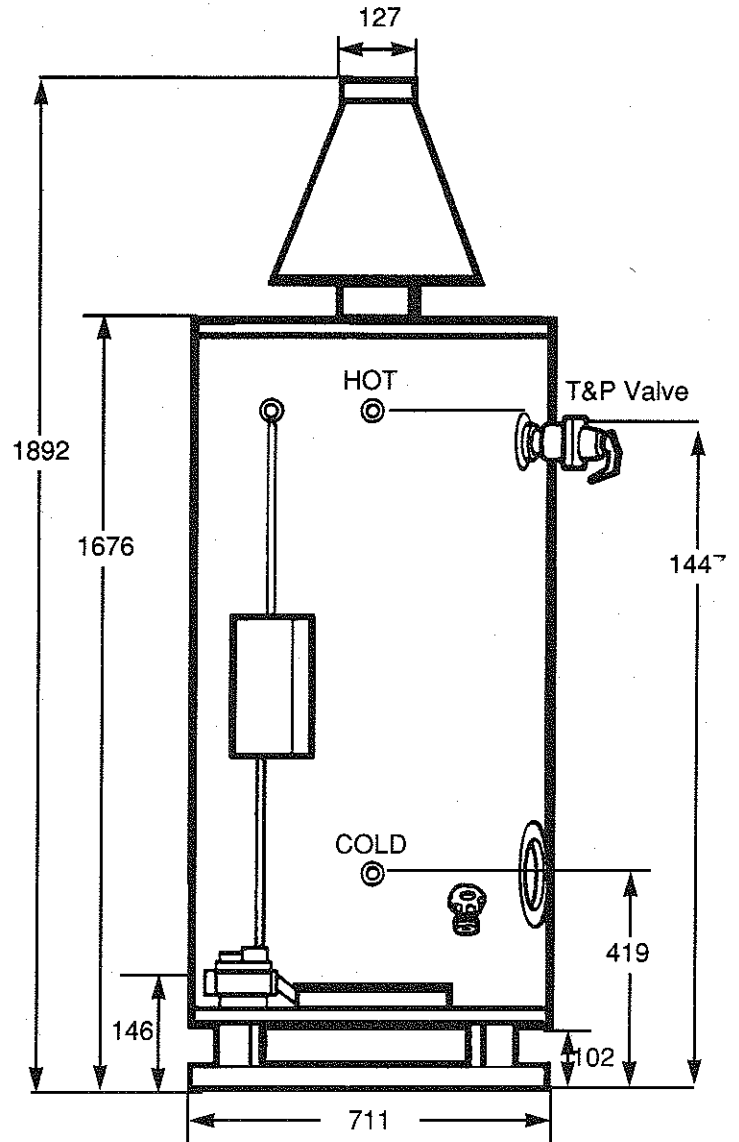

All dimensions are in mm

# Technical Data

## Technical Data SBT 80-500 NE

Continuous at 80°F 44°C temperature rise	2131 litre/hr	469 UK gal/hr
Storage capacity	303 litres	67 UK gal
Weight filled	728kg	1600lb
Time to recover storage with 44°C temperature rise	9 minutes	9 minutes
Input rate	13.75m <sup>3</sup> /hr	479 ft <sup>3</sup> /hr
Input gross	147kW	500,000 Btu/hr
Maximum working head	10.3 bar	150 psig.
Minimum working head	3 mtrs	10 ft
Nominal gas inlet pressure (natural gas)	17.5 mbar	7 in wg
Maximum gas inlet pressure	35 mbar	14 in wg
Burner setting pressure	10 mbar	4 in wg
Injector size	3.0mm	-
Approx flue gas	206 m <sup>3</sup> /hr	7185 ft <sup>3</sup> /hr
Approx flue gas temperature	238°C	460°F
Water connections -cold inlet -hot inlet	1½ BSP 1½ BSP	1½ BSP 1½ BSP
Open Vent	25mm	Minimum 1"
Cold feed pipe	19mm	Minimum ¾"
Gas connection	-	1" BSP
Draught diverter outlet size	254mm	10"
Shipping weight	423kg	930lbs
MINIMUM CLEARANCE		
Sides and Rear	152mm	6"
Front	610mm	24"
Above	1030mm	40.5"
Natural Ventilation: Air direct from outside		
High level	331 cm <sup>2</sup>	50"
Low level	661 cm <sup>2</sup>	100"
Safety Valve	19mm	1"
BS759 or BS6759 -Max Rating	11 Bar	160 psi
Electrical Rating	240V - 1 amp or less	

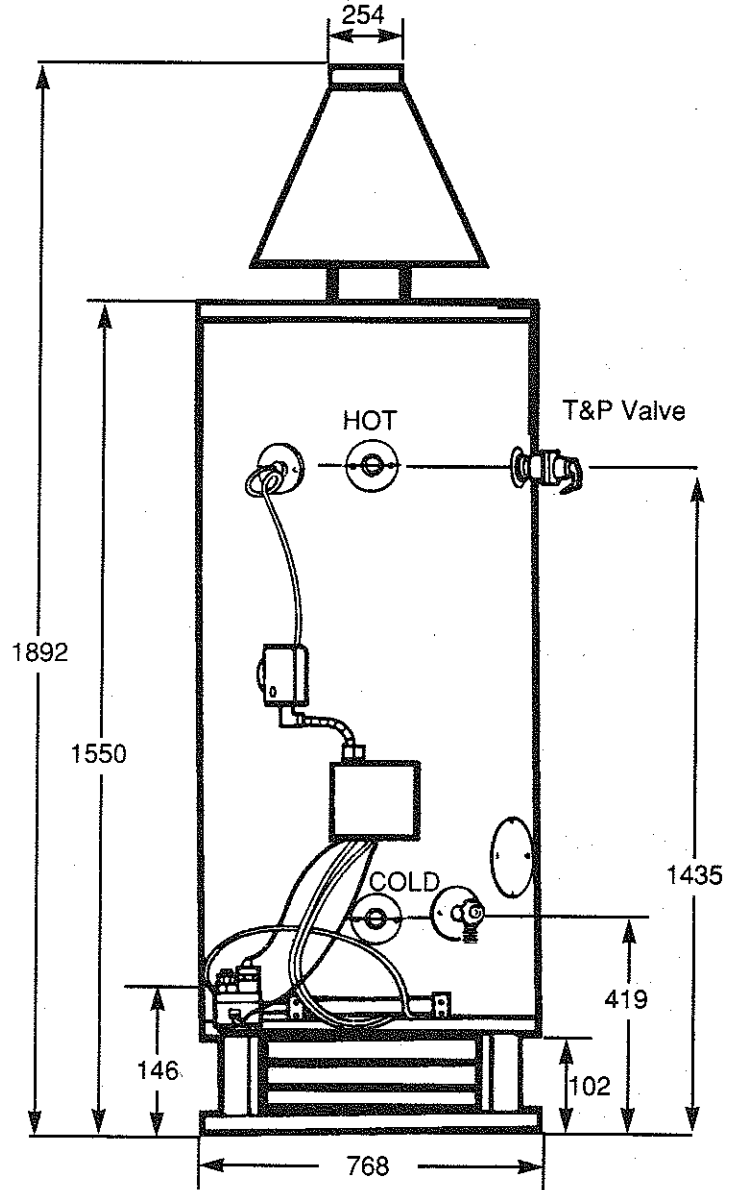

All dimensions are in mm

# Installation

## Related Documents

The installation of the storage water heater must be in accordance with the relevant requirements of the Gas Safety (Installation and Use) Regulations: 1984 and Byelaws of the local water undertaking, the Model Water Byelaws (1986) and the Building Regulations.

Also, it should be in accordance with any relevant requirements of the Local Authority, the local Gas Region, and the requirements of the following British Standard Codes of Practice:

BS 6644: 1986	Installation of Gas Fired Hot Water Boilers 60 kw to 2 MW
1M/11	Flues for Industrial and Commercial Gas Fired Boilers
BS 6891	Low Pressure Installation Pipes
CP 342: Part 2	Centralized Hot Water Supply

The installation must conform to commercial standards but the following may be used, where necessary, for further guidance.

BS 5540: Part 1: 1978	Flues for Gas Appliances up to 60 kw
Bs 5440: Part 2: 1976	Air Supply For Gas Appliances up to 60 kw
Bs 5546: 1979	Installation of Gas Hot Water Supplies for Domestic Purposes (2nd Family Gases).

British Standards Institution publications are available by writing to: BSI, 2 Park Street, London W1A 2BS. Telephone: 071 629-9000

It is the law that all gas appliances are installed and serviced by competent persons in accordance with the above regulations. It is in your own interest and that of safety to ensure that the law is complied with.

## Location Selection

The location of the storage water heater must permit a satisfactory flue and an adequate air supply. The location must also provide the minimum clearances for servicing and air circulation around the water heater. The water heater must not be installed in a bedroom, bed sitting room, or a room containing a bath or shower. They are considered unsuitable for installation in individual dwellings e.g. houses, flats or hotel rooms. The floor on which the heater is installed must be flat, level, and of sufficient load bearing capacity to support the weight of the filled heater with allowance for the weight of additional pipework bearing on the appliance.

A clearance of 610 mm (24") should be left at the front of the heater for removal of the burner assembly and 1030 mm (40.5") above the heater for removal of the flue baffles and anode rods. Minimum clearances at the sides and rear of the heater should be 150 mm (6").

The location selected should be as close to the stack or chimney as practical and as centralized with the piping system as possible. It should be located in an area not subject to freezing temperatures.

The water heater must not be installed on carpeting. Carpeting must be protected by a suitable panel beneath the appliance extending beyond the full width and depth of the appliance by at least three inches in any direction.

Any combustible material adjacent to the heater must be so placed or shielded as to ensure that its temperature does not exceed 65°C (150°F).

## Combustion and Ventilation Air Supply

Detailed recommendations for combustion and ventilation air supplies are given in British Standard 6644: 1986. The following notes are intended to give general guidance.

The space housing the water heater installation must have permanent air vents communicating directly with the outside air, at high and low level. Where communication with the outside air is possible only by means of high level air vents, ducting down to floor level for the lower vents must be used.

The natural ventilation openings at high and low levels should be as specified in the Technical Data Table with the addition of 4.5 cm<sup>2</sup>/kw (1 in<sup>2</sup> per 5000 BTU/h) at low level and 2.25 cm<sup>2</sup> (1 in<sup>2</sup> per 10,000 BTU/h) at high level for any additional appliances in the room or compartment.

Air vents should have negligible resistance and must not be sited in any position where they are likely to be easily blocked or flooded or in a position where they are likely to be easily blocked or flooded or in a position adjacent to an extraction system which is carrying flammable vapor.

Grilles or louvres should be designed so that high velocity air streams are minimized in the boiler house.

If the water heater is installed in hairdressers premises, barber shops, dry cleaning establishments or laundry facilities, it is imperative that the combustion and ventilation air must not be contaminated. Sprays or materials emitting volatile vapors can be a source of ignition from the permanent pilot burner in the water heater. Propellants of aerosol sprays and fumes of volatile compounds, in addition to being highly flammable, will also change to corrosive hydrochloric or hydrofluoric acid when exposed to the combustion products of the water heater. The results may be hazardous, cause service problems and produce failure.

## Effects of an Extract Fan

If there is any type of extraction fan fitted in the premises, there is a possibility that if adequate air inlet areas from the outside are not provided, spillage of the products of combustion from the water heater flue could occur when the fan is in operation. Where such installations occur, a spillage test as detailed in BS 5440: Part 1, Appendix B must be carried out and any necessary corrective action taken.

# Installation (cont'd)

## Gas Meter

The gas piping to the water heater is connected to a gas meter by the local Gas Region or the local Gas Region Contractor. An existing gas meter and service should be checked preferably by the local Gas Region to ensure that the meter is adequate to deal with the additional rate of gas supply required.

## Gas Piping

Installation of the gas supply pipes should be in accordance with BS 6891. A gas line of sufficient size should be run to the water heater. Make sure the gas supplied is of the same type as listed on the data badge.

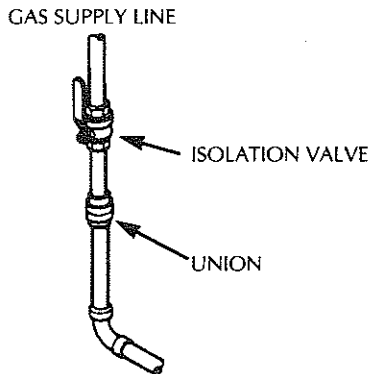

There must be:

- A readily accessible and clearly identified manual isolation valve in the gas supply in accordance with the Gas Safety (Installation and Use) Regulations: 1984
- A ground joint union between the manual isolation valve and the appliance control valve to permit servicing of the unit.

To prevent damage, care must be taken not to allow the torque to be applied across the gas control when attaching the gas supply pipe to the control valve inlet.

Before commissioning the heater, the installation pipes must be tested for soundness and purged, see BS 6891. When the gas line is tested, it should be disconnected from the gas control valve on the heater and capped. If the gas control is subjected to pressures in excess of 35 m bar (14 inches W.G.), the damage to the gas valve could result in an extremely hazardous condition. The manufacturer of the water heater will not be liable either direct or contingent for incidental or consequential damages in the event these instructions are not followed.

CORRECT GAS PIPE DIAMETER (Inches) FOR WATER HEATERS OPERATING ON NATURAL GAS							
Total Input kw (BTU/h)	Distance from Meter, In Metres (Feet)						
	9 (30)	18 (60)	27 (90)	36 (120)	46 (150)	55 (180)	64 (210)
22 (75,100)	3/4	1	1	1	1 1/4	1 1/4	1 1/4
44 (150,000)	3/4	1	1	1	1 1/4	1 1/4	1 1/4
59 (200,000)	1	1 1/4	1 1/4	1 1/4	1 1/4	1 1/4	1 1/4
88 (300,000)	1 1/4	1 1/4	1 1/4	1 1/2	1 1/2	1 1/2	1 1/2
117 (400,000)	1 1/4	1 1/2	1 1/2	1 1/2	2	2	2
147 (500,000)	1 1/4	1 1/2	2	2	2	2	2
176 (600,000)	1 1/2	2	2	2	2	2	2
220 (750,000)	1 1/2	2	2	2	3	3	3

## Flue System

Detailed recommendations for flues are given in British Standard 6644: Clause 20, BS 5440: Part 1, and 1M/11. The following notes are intended to give general guidance.

- a. All flue joints must be made "socket up" to retain any condensate within the flue.
- b. All products of combustion and flue gases must be completely removed to the outside air without spillage at the draught diverter.
- c. Horizontal runs of pipes and 90° bends/elbows should be avoided.
- d. The cross sectional area of the flue serving the water heater must not be less than the area of the outlet of the draught diverter.
- e. The draught diverter supplied with the water heater must be attached to the flue spigot at the top of the unit.
- f. Observe clearances from all combustible materials, i.e. 50mm except where the flue passes through a non-combustible sleeve where clearance is at least 25 mm.
- g. Flue pipes and fittings should be constructed from materials, which are asbestos free, robust, durable, corrosion resistant and non-combustible material complying with BS 5854, BS 715, or BS 4076.
- h. If double wall flue pipe is used, it must be of a type accepted by British Gas.
- i. Use a split flue clip or flange joint close to the diverter for ease of servicing.
- j. The flue pipe should be adequately supported to ensure weight is not transferred to the draught diverter.
- k. The flue connecting pipe shall not enter the chimney within 250 mm (10 inches) of its base, shall not protrude beyond its inner face and shall enter with an upward sweep. There must be access to examine and maintain the entry point.

A flue pipe constructed from one of the materials used for flue pipes and fittings referred to in note "g" above, should form the initial connection to the chimney. Alternatively, a chimney may be lined with a stainless steel flexible flue liner or any other liner acceptable to British Gas. The number of joints must be kept to a minimum.

Before connecting a water heater to a flue which has been previously used, the flue should be thoroughly swept clean of any soot and loose material. If a register plate, restrictor plate, damper, etc. is fitted in a chimney flue, it must be removed before connecting the water heater to the flue. The flue should terminate in accordance with the relevant recommendations given in British Standard 5440: Part 1, Table 4 and BS 6644 Clause 20.5.

A suitable terminal preferably of a type that has been tested and found to be satisfactory by British Gas must be fitted to the flue outlet. The terminal should have a minimum resistance to the egress of combustion products and have effective protection against the entry of rain, snow, leaves, birds, etc. The point of termination must not be within 600 mm (24 inches) of an openable window, air vent or other ventilation opening, nor in an area of pressure which will cause downblow. For further termination guidance consult BS 5440: Part 1 and 1M/11.

# Installation (cont'd)

## Common Flues

- Where two or more gas fired appliances are to be connected to a common natural draught flue, the appliances shall be installed in the same room, shall have the same type of burner system and the flue shall be sized so as to ensure complete evacuation of the flue products from the whole installation.
- All flues whether single or combined must be adequately supported.
- Where one appliance is likely to be used more regularly or for longer periods than other in a group, it shall be connected at the point nearest to the main flue.
- When flues are combined, the area of the combined flue should be equal to the area of all flues feeding it.

## Water Connections

Detailed recommendations for the water system are given in British Standards 5546 and 6644 and Code of Practice CP 342 Part 2. The following notes are of particular importance.

- The water heater should be fitted to an open vented cold water feed cistern or static water tank. The cistern should be fitted with a stop valve and its capacity should be in accordance with the local water byelaws and in addition must always be greater than the hourly recovery rate of the heater. (See Technical Data Sheet for Recovery Rate)
- It is recommended that copper tubing, complying with British Standard 2871: Part 1 is used for water carrying pipework.

- All pipes must be supported as shown in Tables 4 (a) and 4 (c) CP 342.
- All pipework situated in areas which may be exposed to freezing conditions should be insulated.
- Drainage taps must be located in accessible positions which will permit the draining of the whole system. Draining taps should be at least ½ inch nominal size and be in accordance with BS 2879.
- A safety valve to BS 759 or BS 6759 shall be fitted directly to each appliance or not more than one (1) metre along the flow pipe, which should be not less than the size of the hot connection at the heater. The safety valve should be of the spring loaded type, not less than 19 mm (¾ in.) diameter and have a maximum pressure release rating of 160 PSI should preferably be adjustable and set to the working pressure plus 0.7 bar (10 lb/in<sup>2</sup>).  
(NB Metres head x 10.2 = bar; Feet head x 2.3 = lb/in<sup>2</sup>)

- **The Open Vent** must be connected, normally from the top of the flow pipe of the heater, rising continuously to discharge over the old feed cistern. Its size must not be less than that specified in the Technical Data Table. It must not be valved and must be insulated along any part where freezing may occur.
- **The Cold Feed Pipe** should be valved as shown and not be less than the size specified in the Technical Data table.

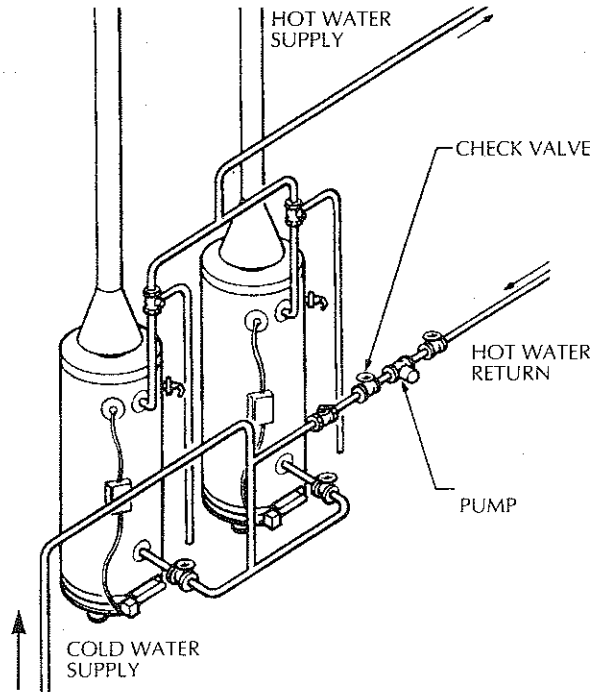
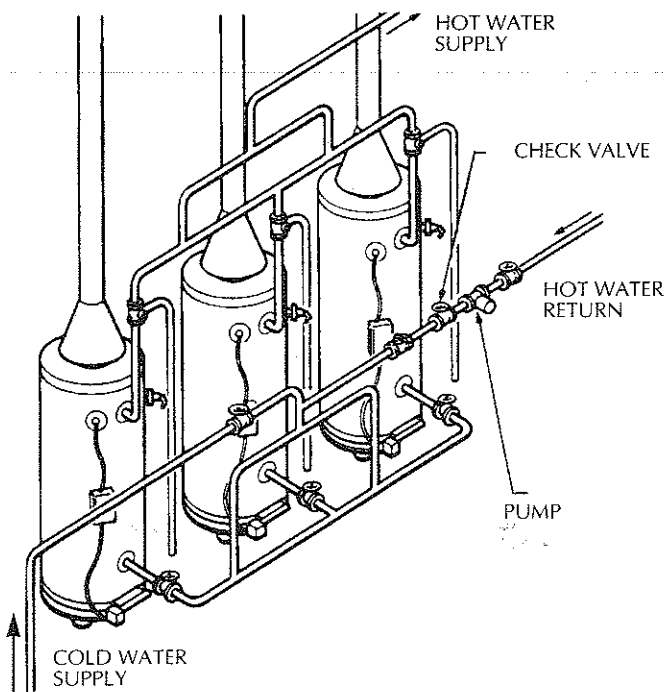

### Three important conditions that must be noted on installations where water heaters are manifolded.

1. All water heaters must be the same model.
2. All water heaters must be evenly spaced to provide identical number of turns, length and size of pipes in each manifold. This is absolutely necessary to ensure a balanced condition to all water heaters in the installation.
3. All water heaters are marked identifying the type (instantaneous storage or circulation) and installation must be appropriate for that type.

All heaters are supplied complete with Magna Charger (not shown) installed in each cold water feed line to the heater.

# Installation (cont'd)

## Water Connections (cont'd)

Dead legs of hot water pipes to draw off points should be as short as possible and should not exceed the lengths laid down in British Standard 5546: 1979, Table 4. Maximum lengths of dead leg piping are listed below.

Pipes not exceeding 22 mm (¾ in.) - max. dead leg length 12 m (39 ft.)

Pipes in range of 22-28 mm (¾ - 1 in.) - max. dead leg length 7.5 (25 ft.)

Pipes greater than 28 mm ID (1 in.) - max. dead leg length 3 m (10 ft.)

If lengths required are greater than those mentioned, a return circuit must be fitted.

## Water Treatment

The use of water softening equipment is strongly recommended in all cases where conditions of high or extreme water hardness exist.

When a water treatment plant (water softener) is used in conjunction with State water heaters, it is recommended that the total hardness be reduced to 50-85 mg/l. (50-85 ppm).

High water temperatures generally cause an increase in corrosion and scale forming activity; waters below 60°C (140°F) scale and corrode less, thus, it is desirable to keep the water temperature as low as possible.

---

### IMPORTANT NOTICE

**Warranty on this water heater will not be valid if lime or scale deposits are allowed to accumulate causing failure of the tank due to restricted heat transfer. IN HARD WATER AREAS, CLEANING MUST BE PERFORMED AT LEAST AS OFTEN AS EVERY 90 DAYS. Failure to keep accurate records of dates of each cleaning will constitute lack of proper maintenance and void the warranty.**

---

## Temperature and Pressure Relief Valve

For protection against excessive temperature and pressure in this water heater, it is the recommendation of the manufacturer that a combination temperature and pressure relief valve be installed. In any case a safety valve to BS 759 or BS 6759 shall be fitted.

The safety valve should be fitted directly on the appliance at the tapping provided, or, failing this, must be fitted no further than one metre along the flow pipe between the heater and the next valve in line. The safety valve should be of the spring loaded type, not less than 19 mm (¾") diameter and have a maximum pressure release rating of 11 bar (160 PSI). It should preferably be adjustable and set to the working pressure of the tank plus 0.7 bar (10 PSI).

To prevent bodily injury, hazard to life or damage to property, the relief valve must be allowed to discharge water in large quantities should circumstances demand. Orient the valve or provide tubing so that any discharge line will exit only within six (6) inches above, or at any distance below the structural floor.

The Discharge Pipe:

- Must not be smaller in size than the outlet pipe size of the valve.
- Must not be plugged or blocked.
- Must be of material serviceable for temperatures up to 120°C (250°F) or greater.
- Must be installed so as to allow complete drainage of both temperature-pressure relief valve, and the discharge pipe.
- Must terminate at an adequate drain.

The temperature and pressure relief valve should be manually operated at least once a year. Caution should be taken to ensure that (1) no one is in front of or around the outlet of the temperature-pressure relief valve discharge line and (2) that the water manually discharged will not cause any property damage. If after manually operating the valve it fails to completely reset and continues to release water, immediately close the cold water inlet to the water heater, follow the draining instructions, and replace the temperature-pressure relief valve with a new one.

# Operation

## Before Operating Water Heater

### CAUTION

The electrical supply to this water heater must NOT be turned on before the tank is completely full of water and the gas supply is available. Because there is normally a certain amount of air in a gas line when a new water heater has been installed, it may be necessary to resequence the water heater several times before it lights on its initial start-up.

### WARNING

**BEFORE LIGHTING THE WATER HEATER:** Be certain water heater and system are filled with water. Expel air by opening all hot water outlets. Close outlets and inspect system for leaks; repair if necessary.

These models are equipped with an intermittent ignition system. For the pilot light to light and the burner to come on, the water heater's thermostat must call for heat. Then the system will begin sequencing, each section proving itself before actual pilot ignition takes place.

Before the water heater will operate:

1. The control system must be connected to a 240V power supply. This control system has an overall rating of 12 amps or less: The water heater must be securely and adequately grounded. This should be accomplished by using a grounded conductor from the service panel to the ground lug located on the terminal block in the junction box of the water heater.
2. The on/off toggle switch, located on the junction box must be in the "ON" position for the electrical control system of the water heater to operate.
3. The gas control knob, located on the gas control valve must be turned to the "ON" position for the electrical control system of the water heater to operate.
4. The gas control knob, located on the gas control valve must be turned to the "ON" position for the gas to be able to flow. **IMPORTANT:** Do not use gas control knob to adjust gas input.
5. The manual E.C.O. must be in the closed position, see "COMPENSATING THERMOSTAT WITH MANUAL E.C.O."

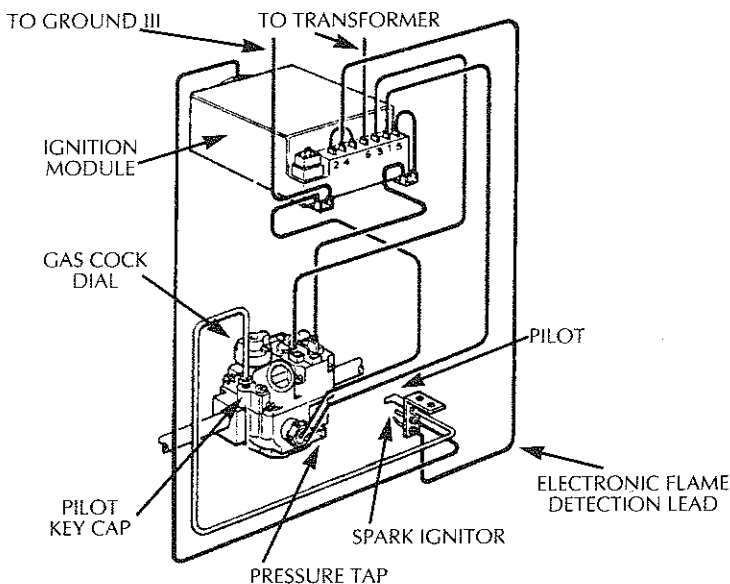

## Pilot Burner Adjustment

Remove pilot key cap. Turn pilot adjusting screw (counterclockwise to open, clockwise to close) until pilot burns with a strong blue flame. Do not allow pilot flame to rise off or burn lazily. Replace pilot key cap.

## Main Burner Air Adjustment

These models have a metered air supply burner which requires no further adjustments.

## Operational Sequence – Natural Gas Only

When the thermostat calls for heat, a circuit is completed to the ignition module. The ignition module will then complete a circuit, simultaneously, to the spark ignitor and to the gas pilot valve solenoid. The spark ignitor will begin sparking and the gas pilot solenoid will open allowing gas to pass to the pilot. When pilot flame has been established, the flame sensor in the pilot burner assembly will signal the ignition module, shutting off the spark ignitor. The ignition module will now complete a circuit to the gas control valve solenoid, which will open, and allow gas to pass to the burner.

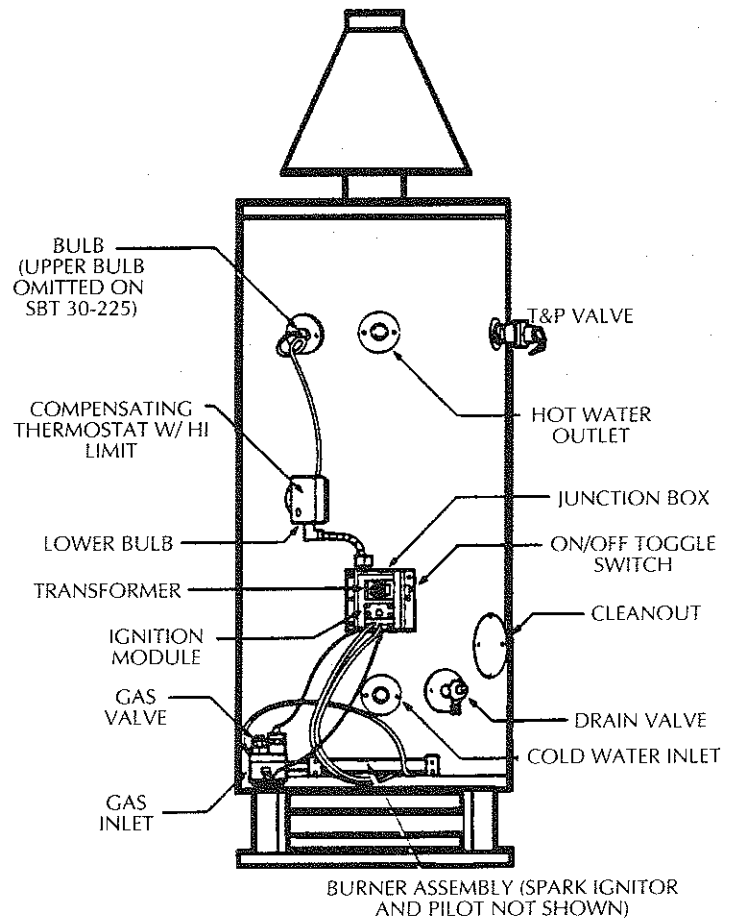



# Operation (cont'd)

## Safety Sequence – Natural Gas Only

During a period when the thermostat is calling for heat and there was an interruption of the pilot flame, the gas valve solenoid will close instantly, shutting off the supply of gas to the burner. The pilot valve solenoid will remain open allowing gas to flow to the pilot. The ignition module will complete a circuit to the spark ignitor, which will begin sparking.

1. If the pilot flame **is** re-established the gas valve will open allowing gas to the burner, and the water heater will resume operation.
2. If the pilot **is not** re-established the gas valve solenoid will remain closed. The pilot valve solenoid will remain open allowing gas to pass to the pilot. The spark ignitor will continue until the pilot flame is re-established, or the water heater is re-sequenced by turning the on/off toggle switch "OFF" and then "ON".

## Compensating Thermostat with Manual E.C.O.

The water temperature dial is set at the lowest position during manufacture and must be turned to the desired setting by the user. The faceplate of the thermostat has been labelled with a range of temperature settings. No gas fixed water heater will provide exact water temperature at all times. Some people are more likely to be permanently injured by hot water than others; include the elderly, children, the infirm, or the handicapped. Before immersing yourself or anyone else in hot water, be sure to check the water.

## Water Temperatures

### WARNING

**HOTTER WATER INCREASES THE RISK OF SCALD INJURY.**

Remember that you can still be scalded with water temperatures as low as 45°C (110°F).

The 49°C (120°F) setting is the preferred starting point. For the most efficient operation of the water heater, the thermostat should be set at the lowest point for the consumer's need.

Turn power off, remove the outer cover to set desired temperature by adjusting the temperature dial. The E.C.O. will activate if the water temperature exceeds 93.3°C (200°F) and will not reset itself. If it is activated, turn off current to the water heater. Then push black reset button and restore power to the water heater.

**NOTE: The reset button cannot be reset until the water temperature lowers to 49°C (120°F).**

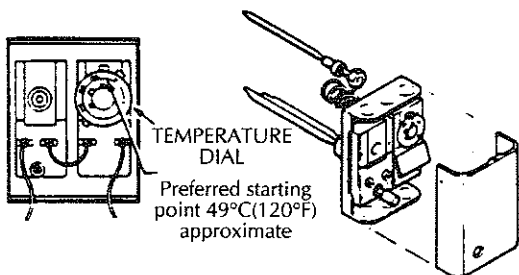

## Burner Inspection

At least every 12 months a visual inspection should be made of the main burner and pilot burner. The drawing below is for your reference.

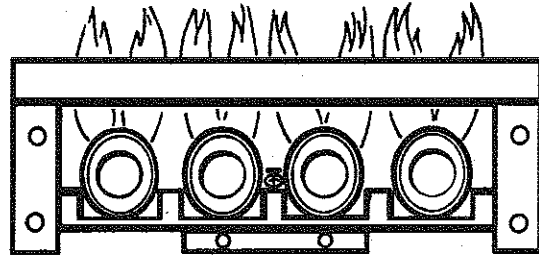

## Burner Cleaning

IN THE EVENT THE BURNER NEEDS CLEANING, USE THE FOLLOWING INSTRUCTIONS.

If inspection of the burner shows that cleaning is required, turn the gas control knob clockwise (  ) to the "OFF" position, depressing slightly.

**NOTE: Knob cannot be turned from "PILOT" to "OFF" unless knob is depressed slightly. DO NOT FORCE.**

Loose deposits on or around the burner can be removed by carefully using the hose of a vacuum cleaner inserted through the access door of the water heater. If the burner needs to be removed for additional cleaning, it is recommended that a qualified serviceman be called to remove, clean, and correct the problem that required the burner to need cleaning.

## FOR YOUR SAFETY READ BEFORE LIGHTING

### WARNING

If you do not follow these instructions exactly, a fire or explosion may result causing property damage, personal injury or loss of life.

- A. This appliance is equipped with an ignition device which automatically lights the pilot. **Do not try to light the pilot by hand.**
- B. **BEFORE OPERATING** smell all around the appliance area for gas. Be sure to smell next to the floor because some gas is heavier than air and will settle on the floor.
- WHAT TO DO IF YOU SMELL GAS**
- Do not try to light any appliance.
  - Do not touch any electric switch; do not use any phone in your building.
  - Immediately call your gas supplier from a neighbor's phone. Follow the gas supplier's instructions.
  - If you cannot reach your gas supplier, call the fire department.
- C. Use only your hand to push in or turn the gas control knob. Never use tools. If the knob will not push in or turn by hand, don't try to repair it, call a qualified service technician. Force or attempted repair may result in a fire or explosion.
- D. Do not use this appliance if any part has been under water. Immediately call a qualified service technician to inspect the appliance and to replace any part of the control system and any gas control which has been under water.

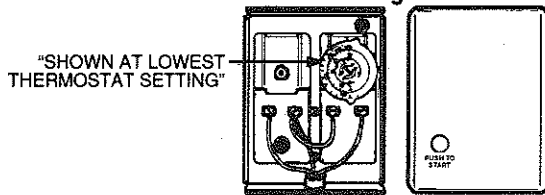

## LIGHTING INSTRUCTIONS

1. **STOP!** Read the safety information above on this label.
2. Turn off all electrical power to the water heater.
3. Remove thermostat access cover.
4. Set the thermostat to lowest setting.

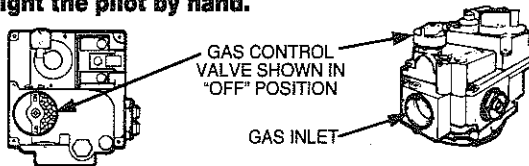

5. This appliance is equipped with an ignition device which automatically lights the pilot. **Do not try to light the pilot by hand.**



6. Turn knob on gas control clockwise  to "OFF" position.
7. Wait five (5) minutes to clear out any gas. If you then smell gas, **STOP!** Follow "B" in the safety information above on this label. If you don't smell gas, go to the next step.
8. At arms length away, turn gas control knob counter-clockwise  to the full "ON" position. **WARNING Do not use gas control knob to regulate gas flow.**
9. At arms length away, set the thermostat to desired setting. The 120°F setting which approximates 120°F is preferred starting point. If hotter water is desired, see instruction manual and "warning" below.
10. Replace thermostat access cover.
11. Turn on all electric power to the appliance.
12. If the appliance will not operate, follow the instructions "To Turn Off Gas To Appliance" and call your service technician or gas supplier.

### WARNING

Hotter water increases the risk of scald injury. Before changing temperature setting see instruction manual. For operation at outlet water temperature not in excess of 180°F.

## TO TURN OFF GAS TO APPLIANCE

1. Turn off all electric power to the appliance if service is to be performed.
2. Remove thermostat-access cover.
3. Set the thermostat to lowest setting.
4. Turn gas control knob clockwise  to "OFF" position. **DO NOT FORCE.**
5. Replace thermostat access cover.

### WARNING

This water heater is equipped for one type gas only. Check the rating plate near the gas control valve for the correct gas. Do not use this water heater with any gas other than the one listed on the rating plate. Failure to use the correct gas can cause problems which can result in death, serious bodily injury, or property damage. If you have any questions or doubts consult your gas supplier or gas utility.

# Wiring Diagrams

## Wiring Diagram Commercial Gas UK Models

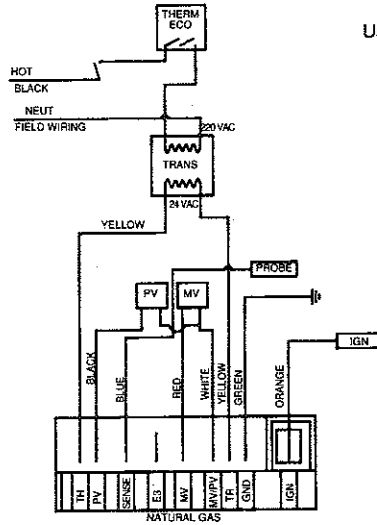
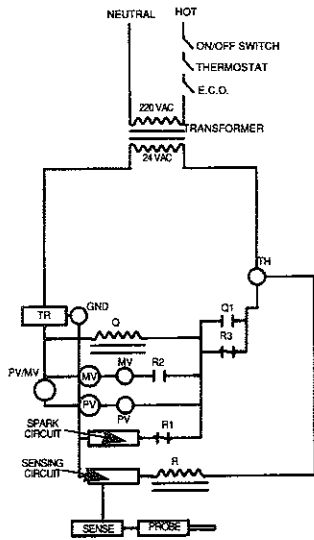

Wiring Diagram  
Using Robertshaw Ignition Module

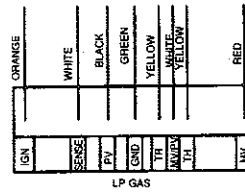

You must provide all wiring of the proper size outside of the water heater. You must obey local codes and electricity utility requirements when you install this wiring.

This appliance must be electrically grounded in accordance with local codes or, in the absence of local codes, with the national electrical codes ANSI/NFPA No. 70-1992.

**NOTE: If any of the original wire, as supplied with the water heater, must be replaced, it must be replaced with 105C. wire or its equivalent.**

# Replacement of Parts

KEY NO.	PART DESCRIPTION	MODEL NUMBERS						
		30-225	80-180	75-300	100-400	80-500	75-155	75-250
		PART NUMBERS						
1	Draft Hood	9002222	9002223	9002222	9002221	9002220	9002223	9002222
2	Anode Rod (each)	9001909	9000921	9000921	9000921	9000921	9001652	9000921
3	Flue Baffle (each)	9001927	9002099	9002180	9002098	9002191	9002177	*9002188
4	Temperature-Pressure Relief	9001306	9001656	9001306	9001748	9001748	9001656	9001306
5	T&P Flange	9001653	9001653	9001653	9001653	9001653	9001653	9001653
6	Outlet Flange	9001653	9001653	9001653	9001653	9001653	9001653	9001653
7	Outlet Nipple	9001908	9001908	9001908	9001663	9001663	9001663	9001908
8	Bulb Flange	9001763	9001763	9001763	9001785	9001785	9001785	9001763
9	Model and Rating Plate	0270137	0270137	0270137	0270137	0270137	0270137	0270137
10	Inlet Flange	9001653	9001653	9001653	9001653	9001653	9001653	9001653
11	Drain Valve Flange	9001763	9001763	9001763	9001763	9001763	9001763	9001763
12	Access Gasket	9000926	9000926	9000926	9000926	9000926	9000926	9000926
13	Access Cover	9000927	9000927	9000927	9000927	9000927	9000927	9000927
14	Access Bolt	9000928	9000928	9000928	9000928	9000928	9000928	9000928
15	Jacket Access Cover	—	—	—	9000383	9000383	—	—
16	Jacket Access Cover	9001764	9001764	9001764	—	—	—	9001764
17	Drain Valve	9000469	9000469	9000469	9000469	9000469	9000469	9000469
18	Bulb Flange	*	9001763	9001763	9001785	9001785	9001785	9001763
19	Bulb Coupling	*	9000922	9000922	9000922	9000922	9000922	9000922
20	Compensating Thermostat w/Manual ECO	9000914	9000913	9000913	9000913	9000913	9000913	9000913
21	Straight Conduit Connector	9000777	9000777	9000777	9000777	9000777	9000777	9000777
22	Conduit (Specify Length)	9000782	9000782	9000782	9000782	9000782	9000783	9000782
23	Straight Conduit Connector	9000777	9000777	9000777	9000777	9000777	9000777	9000777
24	Junction Box	9001765	9001765	9001765	9001765	9001765	9001765	9001765
25	Transformer	9001946	9001946	9001946	9001946	9001946	9001946	9001946
26	Ignitor Module (Natural)	9002226	9002226	9002226	9002226	9002226	9002226	9002226
26	Ignitor Module (L.P.)	9002227	9002227	9002227	9002227	9002227	9002227	9002227
27	Pilot Tubing w/Fittings	9000278	9000278	9000278	9000278	9000278	9000278	9000278
28	Gas Control Valve (Natural)	9000547	9000547	9000547	9000548	9000548	9000547	9000547
28	Gas Control Valve (L.P.)	9000681	9000681	9000681	9000681	9000681	9000681	9000681
29	Burner Orifice (Natural) (each)	0230172	0230167	0230171	0230147	0230110	0230168	0230164
29	Burner Orifice (L.P.)	0230199	0230175	0230098	0230098	0230177	0230200	0230173
30	Gas Manifold	9001904	9001904	9001904	9001781	9001781	9001905	9001904
31	Burner Support Tray	9001912	9001912	9001912	9001768	9001768	9001907	9001912
32	Pilot Orifice (Natural)	9002237	9002237	9002237	9002237	9002237	9002237	9002237
32	Pilot Orifice (L.P.)	9002238	9002238	9002238	9002238	9002238	9002238	9002238
33	Spark Ignitor & Pilot Burner Assy. (Natural)	9002228	9002228	9002228	9002228	9002228	9002228	9002228
33	Spark Ignitor & Pilot Burner Assy. (L.P.)	9002229	9002229	9002229	9002229	9002229	9002229	9002229
34	Burner Tube	9001932	9001932	9001932	9001947	9001947	9001932	9001932
35	On/Off Toggle Switch	9001773	9001773	9001773	9001773	9001773	9001773	9001773
36	Bushing	9001770	9001770	9001770	9001770	9001770	9001770	9001770
37	Securing Bracket	9001911	9001911	9001911	9001771	9001771	9001662	9001662
38	Sandblaster Plus	9000471	9000471	9000471	9000471	9000471	9000471	9000471
39	T&P Extender	—	9000328	—	—	—	9000328	—
40	Nipple	9001892	—	9001892	9000972	9000972	—	9001892

# Replacement of Parts

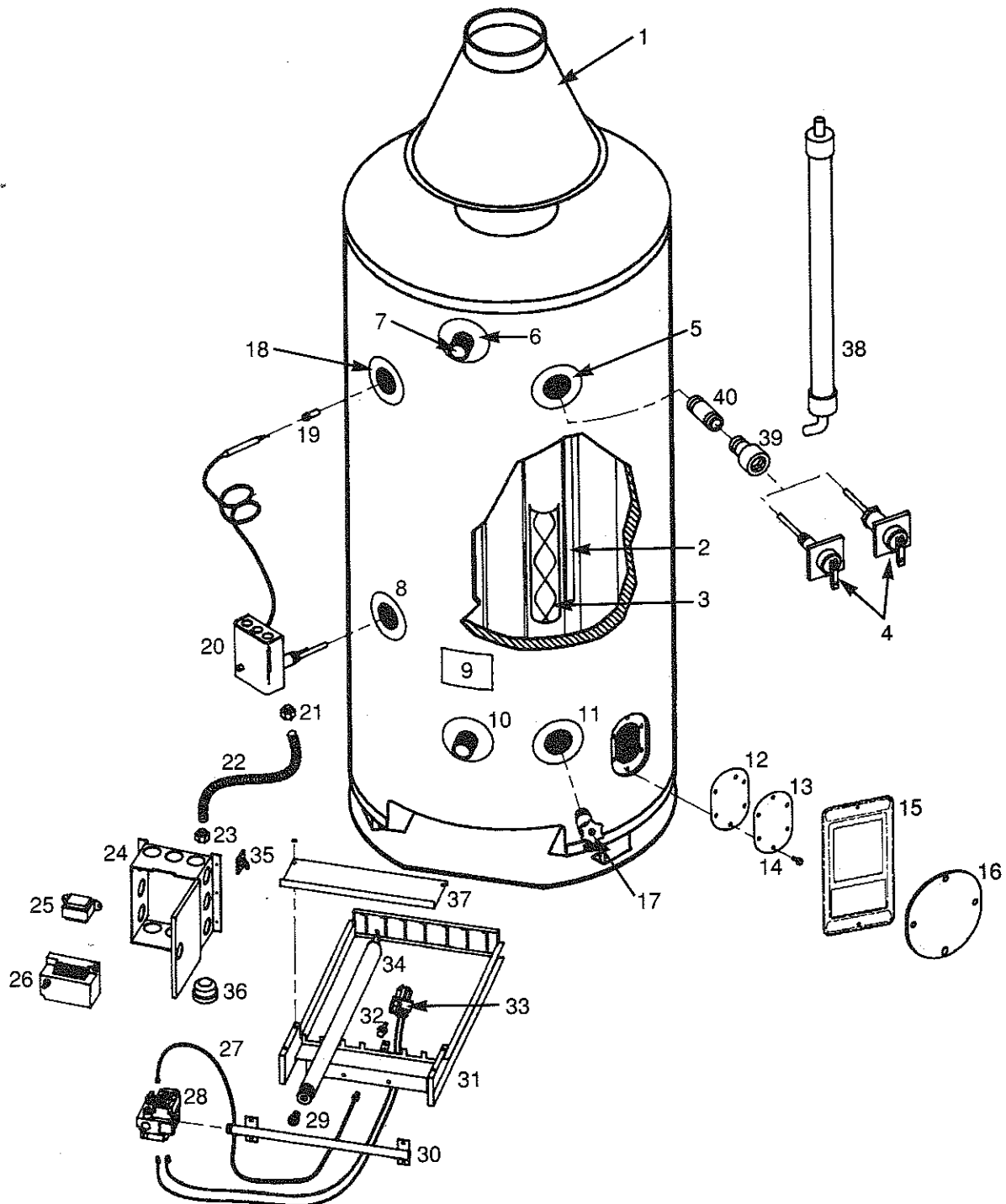







Unit 5, Mitchell Point, Ensign Business Park, Hamble Lane, Hamble, Southampton SO3 5RF  
Tel: (0703) 456497 Fax: (0703) 456468