

HI-SPEC M31

WARM AIR HEATER
System E-T & Basic Control

INSTALLATION, COMMISSIONING & SERVICING INSTRUCTIONS

G.C. NUMBERS: Air Heater 42 451 10



**These instructions are to be left with the User or
adjacent to the Gas Meter**

www.johnsonandstarley.co.uk

RELIABILITY YOU CAN TRUST



Johnson & Starley

CONTENTS

1	Features	3
2	Brief Description	3
3	Heater Compartment & Clearances	4
4	Ventilation & Combustion Air	4
5	Duct System	5
6	Installation Requirements	5
7	Commissioning	10
8	Instructions for User	13
9	Maintenance	14
10	Defect Diagnosis	17
11	System E-T Defect Diagnosis Flow Charts	20
12	Circuit Diagrams	24
13	Functional Diagrams	26
14	List of Spares	28
15	Exploded Diagram	29
16	Dimensions	30
17	Notes	31
18	Important Information	32
19	Benchmark Log Book	33



THE BENCHMARK SCHEME

In order to comply with Building Regulations Part L (Part J in Scotland) the boiler MUST be fitted in accordance with the manufacturer's instructions.

Benchmark places responsibilities on both manufacturers and installers. The purpose is to ensure that customers are provided with the correct equipment for their needs, that it is installed, commissioned and serviced in accordance with the manufacturer's instructions by competent persons and that it meets the requirements of the appropriate Building Regulations. The Benchmark Checklist can be used to demonstrate compliance with Building Regulations and should be provided to the customer for future reference.

Installers are required to carry out installation, commissioning and servicing work in accordance with the Benchmark Code of Practice which is available from the Heating and Hotwater Industry Council who manage and promote the Scheme.

Visit www.centralheating.co.uk for more information.

PLEASE READ THESE INSTRUCTIONS CAREFULLY BEFORE STARTING THE INSTALLATION. ON COMPLETION LEAVE THESE INSTRUCTION WITH THE USER OR AT THE GAS METER.

In the interest of continuous development Johnson and Starley reserve the right to change specification without prior notice. Johnson and Starley prides itself on it's ability to supply spare parts quickly and efficiently.

If your service engineer indicates a problem in obtaining a spare part, advise him to contact Johnson and Starley Spares Department.

1. FEATURES

These appliances have been tested and certified by B G Technology for use with natural gas G20.

Note: If a HIJAN 6 circulator is fitted, the relevant Installation, Commissioning and Servicing Instructions provided with that appliance must also be observed.

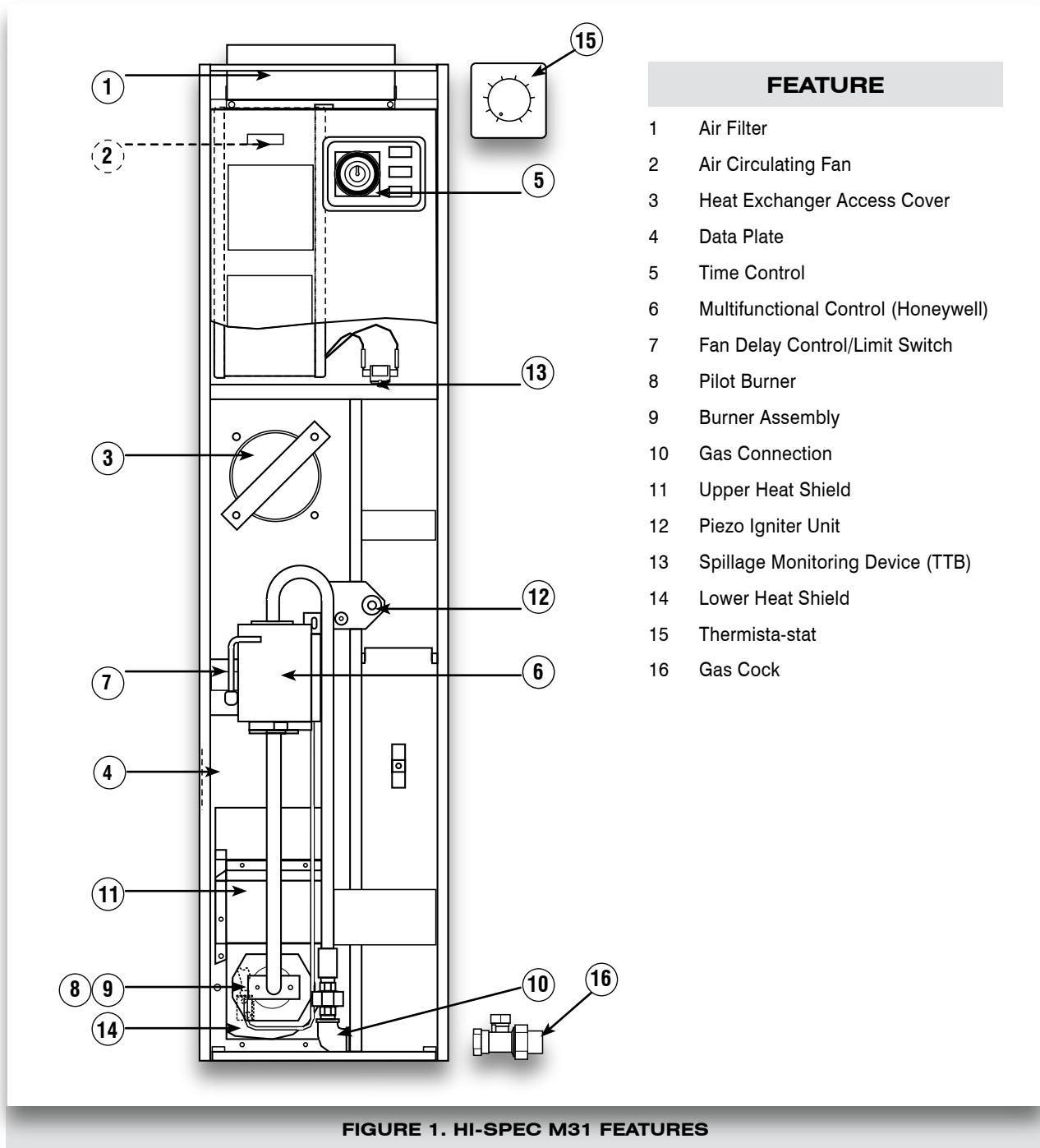

FIGURE 1. HI-SPEC M31 FEATURES

2. BRIEF DESCRIPTION

- 2.1 HI-SPEC M31 is an open-flued, fan assisted downflow, ducted warm air heater, which may be supplied with SYSTEM E-T or BASIC control. A HIJAN 6 circulator is available as an option. A rear rising duct kit is available for this air heater. A Spillage Monitoring Device (TTB) is fitted which senses the temperature in the draught diverter, and shuts down the appliance when this temperature rises due to the presence of flue gases.
- 2.2 The Air heater output can be adjusted between 7.3kW (26.4MJ/h, 25,000Btu/h) and 9.1kW (32.7MJ/h, 31,000Btu/h) "Summer air circulation" of unheated air is available by manual selection (see User's Instructions). HIJAN 6 output is factory set at 3.32kW (11.5MJ/h, 11,340Btu/h), but may be increased to 3.81kW (13.7MJ/h, 13,000Btu/h).

THIS APPLIANCE CONFORMS TO BS EN 45014

Installation shall be in accordance with the current editions of:-

Building Standards (Scotland) (Consolidation) Regulations
Building Regulations
Gas Safety (Installation and Use) Regulations (as amended)
BS 7671 Institute of Electrical Engineers (I.E.E.) Wiring Regulations
BS 6891 Installation of Low Pressure Gas Pipework of up to 28mm (R1) in domestic premises (2nd family gases).
BS 5440 Pt. 1 (Flues for Gas Appliances)
BS 5440 Pt. 2 (Air Supply for Gas Appliances)
BS 5864 Installation of Gas Fired Ducted Air Heaters
British System Design Manual "Gas Fired Warm Air Heating"
Model and Local Authority Bye-laws
BS 5546 Installation of Domestic Hot Water Supplies.

IT IS A STATUTORY REQUIREMENT THAT ALL GAS APPLIANCES MUST BE INSTALLED BY COMPETENT PERSONS, (i.e. GAS SAFE REGISTERED INSTALLERS. GAS SAFE MEMBERSHIP ENQUIRIES - TEL: 0800 408 5500) IN ACCORDANCE WITH THE GAS SAFETY (INSTALLATION AND USE) REGULATIONS (CURRENT EDITION). FAILURE TO COMPLY WITH THESE REGULATIONS MAY LEAD TO PROSECUTION.

3. HEATER COMPARTMENT AND CLEARANCES (See BS 5864)

- 3.1 **IMPORTANT:** If the heater is to be fitted to an existing base duct (warm air plenum), always ensure that installation is carried out such that the rear left hand corner of the heater is aligned with the rear left hand corner of the base duct, so that any overhang or blanking off will be at the front and/or right hand side. In any event, blanking plates must be mechanically secured and all joints sealed.
- 3.2 When the heater is fitted into a compartment, a minimum clearance from the compartment walls of 3mm at the sides and rear, and 75mm (3") at the front must be left. Consideration should also be given to the space required for the removal and replacement of the filter tray and the entry of the gas, water and electrical supplies. If gas and /or water connections are made from a side entry, a minimum clearance of 75mm is required at that side.
- 3.3 For service access, a minimum of 450mm (18") is required at the front of the heater. Space must also be allowed, in a compartment installation, to permit the removal of the heater. The clearance between the appliance and the compartment should be not less than 75mm (3"). However, if clearances are less than 75mm, the internal surface of the compartment must be lined with non-combustible material. The compartment must be of a fixed rigid structure.
- 3.4 In airing cupboard installations, the part used as the air heater compartment must comply with the relevant section of BS 5864 and must be completely separated by either a non-combustible partition or a perforated metal partition with the perforations not exceeding 13mm (½"). The secondary flue must be a tight fit where it passes through the partition and must be suitably protected (see BS 5440: Part 1).
- 3.5 In under-stairs installations, the compartment must comply with the relevant section of BS 5864, provided that in addition, all internal surfaces, including the base, are non-combustible or lined with non-combustible material. This requirement is applicable only to dwellings of more than two storeys.
- 3.6 In free-standing installations, (see instructions packed with free standing kit), only one or two walls will be in close proximity to the air heater; these must be non-combustible.
- 3.7 If the Air Heater is to be installed onto a combustible surface, a suitable base tray is required. However, when a base duct is used, this provides sufficient protection for combustible material and no further insulation is required.
- 3.8 For Slot Fix applications (see instructions supplied with Slot Fix Kit), it is important to ensure that the draught diverter relief is maintained on both sides of the application.
- 3.9 For corner fitting installations, a top closure kit (TP31M for M31 heaters and TP32M for M31 with rear riser B4530) is available.

4. VENTILATION AND COMBUSTION AIR

- 4.1 The room or internal space in which the heater is installed requires a permanent air vent of minimum effective area 51cm² (8in²). The air vent should be either direct to outside air or to an adjacent room or internal space (other than a toilet or bathroom) that itself has an equivalent air vent direct to outside.
- 4.2 Combustion air may be introduced, via a 100mm (4") nominal bore pipe, connected to a return air duct or plenum from a ventilated area and fitted with a lockable damper. The damper should be adjusted to control combustion airflow to 0.0099m³/s (21cfm), (i.e. 1.26m/s [250ft/min] velocity in a 100mm [4"] bore pipe). If this arrangement is used, a non-closeable warm air register **MUST** be provided in the same area as the front of the air heater or heater compartment if a return air grille is not located in that area.
- 4.3 When installed in a compartment, two permanent ventilation openings into the compartment are required, one at high level and one at low level, both communicating either directly with outside air or with a ventilated room or space. The minimum effective areas specified in Table 1 are related to the rated heat input of the Air Heater, and assuming that an HIJAN 6 circulator is fitted.

- 4.4 If any room or area from which air is drawn for ventilation or combustion contains an extract fan, the permanent vents must be sized to ensure that the operation of the appliance(s) at full rate is/are not adversely affected. A spillage test as specified in sub-para 7.8 (Safety Checks) is carried out and any remedial work undertaken.

VENTILATED FROM INSIDE BUILDING	Low level grille 320cm ² (50in ²)
	High level grille 160cm ² (25in ²)
VENTILATED FROM OUT-SIDE BUILDING	Low level grille 160cm ² (25in ²)
	High level grille 80cm ² (13in ²)

TABLE 1. MINIMUM EFFECTIVE AREAS

5. DUCT SYSTEM

(See British Design Manual - Gas fired Warm Air Heating)

5.1 RETURN AIR

- 5.1.1 All return air shall be POSITIVELY ducted from outside the compartment to the top of the unit via a return air duct. It is recommended that the return air duct be not routed directly from the main living area, but from a convenient central area serving the remainder of the dwelling.
- 5.1.2 The return air system should be constructed of fire-resistant material. The flue shall not be run through an area serving as a return air path. It is extremely important that the correct size of return air grilles and ducting is used. For heaters on maximum output the return air duct size should not be less than the equivalent of 250mm x 200mm (10" x 8"). If flexible duct is used the duct diameter should not be less than 300mm (12") diameter. The return air grille should have a free area of not less than 900cm² (140in²).
- 5.1.3 An adequate and unobstructed return air path is essential from areas not served by a directly ducted return and to which warm air is delivered. All such rooms should be fitted with relief grilles which have a free area of 0.0088m²/kW (1in²/250Btu/h) of heat supplied to the room. The only exceptions are kitchens, bathrooms and WC.'s.
- 5.1.4 The return air duct should allow for ease of removal for access to the flue.
- 5.1.5 All duct work in the room or internal space in which the heater is installed shall be mechanically secured, and sealed with ducting tape.

5.2. WARM DELIVERED AIR

- 5.2.1 All duct work, including riser ducts, should be fully insulated with 50mm (2") fibreglass or similar. If short extended duct runs are taken below floor level these should be similarly insulated, and in addition wrapped with a sound vapour proof barrier, and protected from crushing.
- 5.2.2 The duct system should be carefully designed (as given in the guidelines in the British System Design Manual) to suit the needs of its specific heating requirements and building layout. The type of duct system, (i.e. radial/extended plenum/stepped) should be installed using the least number of fittings to minimise airflow resistance. The base duct, which equalises the air pressure to supply ducts, shall be constructed to support the weight of the heater, which shall be secured to the plenum with screws on at least two sides, and sealed using self-adhesive foam strip, ducting tape or sealing compound. All ducting and blanking plates shall be mechanically secured and sealed.

6. INSTALLATION REQUIREMENTS

Note: For circulator Installation Instructions, refer to the relevant instructions provided with the circulator.

6.1 FLUES (see British Standards BS 5440 Pt. 1 Flues)

- 6.1.1 All joints shall be soundly sealed.
- 6.1.2 The flue should be kept as short and warm as possible.
- 6.1.3 Sufficient support brackets shall be installed to bear the weight of the total flue system.
- 6.1.4 The spigot connection of the heater draught diverter will accept internally the spigot end of a non-asbestos flue to BS 567 or twin wall metal flue to BS 715 of nominal 100mm (4") diameter.
- 6.1.5 A split collar should be fitted to provide for flue maintenance or inspection.

- 6.1.6 The flue shall be in accordance with the Building Regulations and British Gas Materials and Installations specification (3rd edition) with regard to clearance and shielding from combustible materials.
- 6.1.7 All materials shall be in accordance with Building Regulations requirements.
- 6.1.8 The flue should run as vertically as possible. Horizontal runs should be avoided if at all possible and any directional change should be as gentle as possible. If there is any doubt about the flue configuration, the equivalent flue height should be determined (see 6.1.10).
- 6.1.9 If the appliance to be fitted is a replacement, the old appliance should be checked for signs of spillage prior to commencement of the installation and appropriate action taken, (i.e. check flue system and renew as necessary).
- 6.1.10 It is recommended that at least 600mm of vertical flue should be provided from the top of the draught diverter (for new installations this shall be incorporated into the flue design). However, when carrying out replacement installations, an existing flue system may be encountered, where the vertical flue above the appliance to the first bend is less than 600mm. In the first instance, the installer must judge whether this distance can be achieved practicably by some means. Where this is not practicable, the existing flue system may be used, providing there is no evidence of spillage from the old appliance (see 6.1.9 above). Every effort must be made, however, to ensure that the existing flue complies in every other way to BS 5440 Part 1, including the visual inspection, flue flow and spillage test described in 4.3.2 of the above standard. Flue configurations may be assessed in terms of equivalent vertical height - details are given in Section 6.1.11. For air heaters, the minimum equivalent vertical height is 1 metre. The installer must make a judgement based on his knowledge and experience and the examination and testing described above as to whether an existing flue system can be used.

Note: Ventilation of the compartment, room or internal space in which the appliance is to be installed must be checked for compliance with the requirements of BS 5440 Part 2 (Ref. Section 4 of these instructions) and upgraded as necessary.

6.1.11 **Calculation method for flue sizing: (from BS 5440: Part 1, Appendix A)**

- This appendix provides a procedure for estimating whether a given flue design is likely to ensure full clearance of combustion products.
- The procedure is based on calculating the 'equivalent height' of the flue under consideration, i.e. that height of the straight vertical circular flue pipe of specific size which will produce the same flow rate as the flue under consideration. The equivalent height is calculated from the formula:

$$H_e = H_a \times \frac{(K_i + K_o)_e}{(K_i + K_o)_a - K_e H_a + \text{Sum } K}$$

where:

H_e is the height of the equivalent flue;

H_a is the vertical height of the actual or proposed flue;

K_i is the inlet resistance of the flue;

K_o is the outlet resistance from the flue;

subscript (e) refers to the equivalent flue diameter;

subscript (a) refers to the actual or proposed flue diameter;

K_e is the resistance per unit length of the equivalent flue;

Sum K is the resistance (other than the inlet and outlet resistance) of the actual or proposed flue.

Note: K and Sum K are obtained from Table 2. K_o and K_i are obtained from Table 3.

- Table 2 gives resistance factors for common flue components for use in the formula. Table 3 contains the appropriate inlet and outlet flue resistances, **(the flue is likely to be satisfactory if its equivalent height exceeds 1m)**.
- Worked Calculation Example:**
A warm air unit with a 100 mm diameter flue spigot, fitted with a pre-fabricated flue system leading to a ridge tile in the loft (refer Fig. 2):

From Table 3

K_{ia}	Inlet resistance of actual flue	=	2.5
K_{oa}	Outlet resistance of actual flue	=	2.5
K_{ie}	Inlet resistance of equivalent flue	=	2.5
K_{oe}	Outlet resistance of the actual flue	=	2.5

From table 2:

Other resistance's of actual flue:

Terminal		=	2.5
Pipe bend	(2 x 0.61)	=	1.22
Pipe	(4 x 1m @ 0.78)	=	3.12
	(5 x 0.3m @ 0.78)	=	1.17
Sum K		=	8.01

Equivalent height :

From the formula

$$H_e = 6.2 \times \frac{(2.5 + 2.5)}{(2.5 + 2.5) - (0.78 \times 6.2) + 8.01}$$

H_e = 3.793 This flue exceeds 1.0m equivalent height and is therefore satisfactory.

COMPONENT	INTERNAL SIZE	RESISTANCE FACTOR
Flue Blocks	197mm x 67mm	0.85 per meter run
	231mm x 65mm	0.65 per meter run
	317mm x 63mm	0.35 per meter run
	140mm x 102mm	0.60 per meter run
	200mm x 75mm	0.60 per meter run
	183mm x 90mm	0.45 per meter run
Pipe	100mm	0.78
	125mm	0.25
	150mm	0.12
Chimney	213mm x 213mm	0.02
90° Elbow	100mm Pipe	1.22 per fitting
	125mm Pipe	0.50 per fitting
	150mm Pipe	0.24 per fitting
45° Elbow	100mm Pipe	0.61 per fitting
	125mm Pipe	0.25 per fitting
	150mm Pipe	0.12 per fitting
	197mm x 67mm	0.30 per fitting
	231mm x 65mm	0.22 per fitting
	317mm x 63mm	0.13 per fitting
Raking Block	Any	0.30 per block
Adaptor Block	Any	0.50 per block
Terminal	100mm Ridge	2.5
	125mm Ridge	1.0
	150mm Ridge	0.48
	100mm GCI	0.6
	125mm GCI	0.25
	150mm GCI	0.12

TABLE 2. RESISTANCE FACTORS FOR USE IN CALCULATING EQUIVALENT HEIGHTS

APPLIANCE	INLET RESISTANCE (K _i)	FLUE	OUTLET RESISTANCE (K _o)
100mm Dia Spigot	2.5	100mm Flue	2.5
125mm Dia Spigot	1.0	125mm Flue	1.0
150mm Dia Spigot	0.48	150mm Flue	0.48

TABLE 3. INLET AND OUTLET RESISTANCE

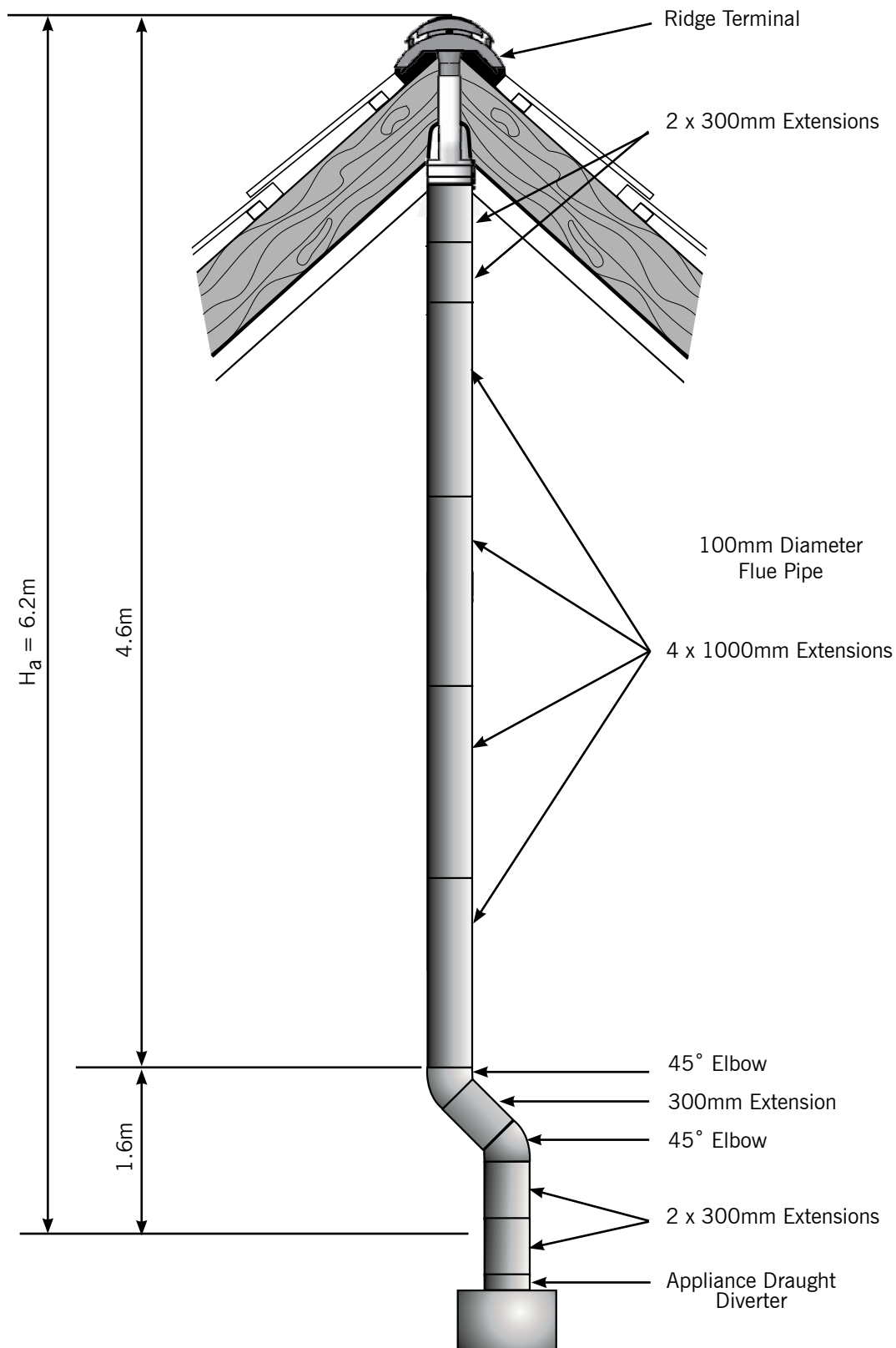

FIGURE 2. WORKED EXAMPLE OF EQUIVALENT FLUE HEIGHT

Note: Ventilation of the compartment, room or internal space in which the appliance is to be installed must be checked for compliance with the requirements of BS 5440 Part 2 (Ref. Section 4 of these instructions) and upgraded as necessary.

- 6.1.12 Special consideration must be given to external flues with a view to prevention of condensation and weathering problems.
- 6.1.13 An approved terminal should always be used; a ridge terminal or "GC1" terminal is specifically recommended. The latter should be positioned in a free air space where it is not shielded by any structure. A minimum of 1m (3ft.) from any vertical or inclined roof structure must be allowed for.
- 6.1.14 Where flue blocks are used, builders should ensure that no obstruction is created during erection. The installer

should ensure that the connection flue does not project beyond the internal wall of the flue blocks and that there is provision for examination and servicing.

6.1.15 **Important:** Before installing the appliance, carry out a visual check of the flue system as directed in the relevant section of BS 5440 Pt. 1, then check the flue performance as follows:-

- a. Close all doors and windows in the room in which the appliance is to be installed.
- b. Introduce some heat into the flue, using a blow torch or other means.
- c. Carry out a flow visualisation check with a smoke pellet at the intended position for the appliance. Ensure that there is discharge of smoke from the correct terminal only, and no spillage into the room. Smoke coming out of other than the correct terminal only, or a down draught or 'no flow' condition, indicates that the flue has failed the test, and the appliance shall not be connected until the defect has been found and rectified, and the test satisfactorily completed.

6.2 ELECTRICAL

6.2.1 Mains

- a. The heater is supplied with mains cable (PVC sheathed, heat resisting to 85°C), 3-core Brown-Blue-Green/Yellow, 6A, 0.75mm²), connected to a terminal block and exiting through the heater at the right hand top. The cable is suitable for a 230V 50Hz supply and shall be connected to the fixed wiring using a double pole switched, fused spur, incorporating a protective earth link. The fuse fitted shall be rated 5A to BS 1362. Connections shall be in accordance with the current edition of I.E.E Regulations BS 7671.
- b. Fan delay control and Limit Switches are not adjustable and are set as follows:
 - i. **Basic Models:** Fan delay control closes at 54°C ± 4.5°C; opens at 40°C ± 3°C.
 - ii. **All Models:** Overheat (Limit) Control opens at 80°C; closes at 60°C.
- c. **SYSTEM E-T MODELS:** An electronic controller (Thermista-stat) is supplied which acts as a room thermostat.
- d. **BASIC MODELS:** A 24V room thermostat (not supplied), that complies with BS 800, BS 3955 and BS 4201 is essential to ensure close control of comfort conditions. An anticipator is located within the thermostat and is graded in amps. The anticipator should be checked and adjusted to 0.2A.

6.2.2 Thermista-stat/Room Thermostat and its location.

- a. The Thermista-stat/Room Thermostat should be located where there is free air circulation approx. 1.5m (5ft) from the floor.
- b. Avoid the following locations:-
 - i. In a room where temperature is greatly affected by the sun or any other heat source, e.g. radiant fire, wall light fittings or TV set.
 - ii. Near an outside door or windows, or on an outside wall.
 - iii. Where affected by warm air ducts, diffusers, waste pipes or the heater itself.
 - iv. Where subject to vibration.
- c. Connect Thermista-stat/Room thermostat wires to control panel terminals '7' and '8' (see Figure 6a/b or 7a/b).

6.3 GAS (See BS 5864 and BS 6891)

- 6.3.1 An independent gas supply pipe from the meter is to be preferred wherever possible. When this is not possible, the pipe must be capable of taking the complete input of the heater and all other gas appliances being served by this same pipe. This supply should be suitably sized to conform to British Standards requirements of no more than 1.0mbar (0.4" wg) pressure drop (See table of discharge in BS 6891).
- 6.3.2 The ½in union gas cock (supplied) must be fitted to the gas inlet of the heater for easy isolation during servicing. The gas pipe should be so fitted and installed as to be durable, substantial and gas tight. To assist in determining where a gas connection may not be tight, a leak detection fluid should be applied around the connection. Under no circumstances should a flame be used to locate a gas leak. Gas entry to the air heater is through either side to a R½ (½" BSP. external [taper] thread).

7. COMMISSIONING

7.1 PREPARATION

- 7.1.1 Ensure that:
- Gas and Electrical supplies are **OFF**.
 - Filter, fan and fan compartments are free from obstructions.
 - All registers or grilles are open and conform to design specifications.
 - Return, relief and ventilation air installations are adequate.

7.2 SYSTEM BALANCING

- 7.2.1 Set the Air Heater electrical supply **ON**.
- 7.2.2 Set the SUMMER AIRFLOW switch to '1'.
- 7.2.3 Balance the system to provide the required volume proportions at the warm air outlets.

Note: If the system includes ceiling diffusers, the air through these should be NOT LESS THAN 1.5m/s (300ft/min), except for very small rooms, (i.e. bathrooms etc.). Outlet faces may require partial blanking in order to achieve this.

- 7.2.4 Set the SUMMER AIRFLOW switch to '0'.

7.3 IGNITION OF PILOT AND MAIN BURNERS

WARNING: If the pilot light is extinguished either intentionally or unintentionally, no attempt should be made to relight the gas for a minimum of 3 minutes. Ensure Electrical supply, time control and Selector switches are set to '**OFF**'.

- 7.3.1 Set the Thermosta-stat/room thermostat to lowest or **OFF** setting.
- 7.3.2 On the Multifunctional Control, remove the Outlet Pressure test point cover, and fit a pressure test gauge (refer Figure 4).
- 7.3.3 Turn the heater Gas supply **ON**, test for gas soundness and purge the whole gas pipe as described in BS 6891.
- 7.3.4 Referring to Figure 4, press and hold the OPERATING CONTROL, and whilst observing the Pilot Burner, repeatedly press the Piezo igniter button until Pilot burner ignites.
- 7.3.5 After 20 seconds release the OPERATING CONTROL and let it spring out; ensure that the Pilot burner remains alight. If the Pilot burner extinguishes, rotate the OPERATING CONTROL clockwise to the '●' position and ensure that the OPERATING CONTROL is fully reset. Wait three minutes and repeat steps 7.3.4 and 7.3.5, holding the OPERATING CONTROL depressed for a longer period until Pilot burner remains alight.
- 7.3.6 With the Pilot Burner lit, allow the operating control to spring out.
- 7.3.7 Ensure that the pilot flame envelops thermocouple tip (refer Figure 3).
- 7.3.8 Set the Heater Electricity supply **ON**.
- 7.3.9 Set the Time Control to required Heating On periods.
- 7.3.10 Set the Selector switch to 'TIMED'.
- 7.3.11 Set the Thermosta-stat or room thermostat to **MAXIMUM**.
- 7.3.12 Ensure that the Main Burner has now ignited.
- 7.3.13 Test for gas leakage at the supply, Multifunctional Control, Pilot and Main Burners using proprietary detection fluid, sealing any leaks found.
- 7.3.14 Allow the air heater to operate for a minimum of 15 minutes to ensure stability.

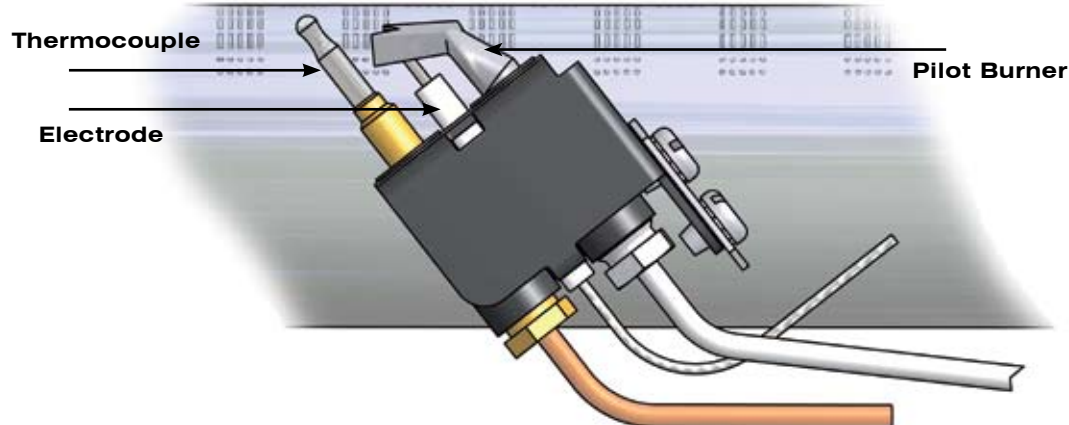

FIGURE 3. PILOT BURNER ASSEMBLY

7.4 MAIN BURNER PRESSURE TEST AND TEMPERATURE RISE CHECK

NOTE: Air heater burners are factory set to provide a nominal high rate output as detailed in sub paragraph 2.2

7.4.1 Referring to Table 4 and Figure 4 below, ensure that the pressure test gauge indicates correct burner pressure, resetting if required as follows:.

- a. At the Multifunctional control:
 - i. Remove the Burner Pressure Adjuster cover.
 - ii. Set the Burner Pressure Adjuster to provide a pressure test gauge indication for the correct burner pressure as detailed in Table 4.
 - iii. Refit the Burner Pressure Adjuster cover.

7.4.2 Apply the pressure set arrows to indicate the appropriate burner pressure on the data badge.

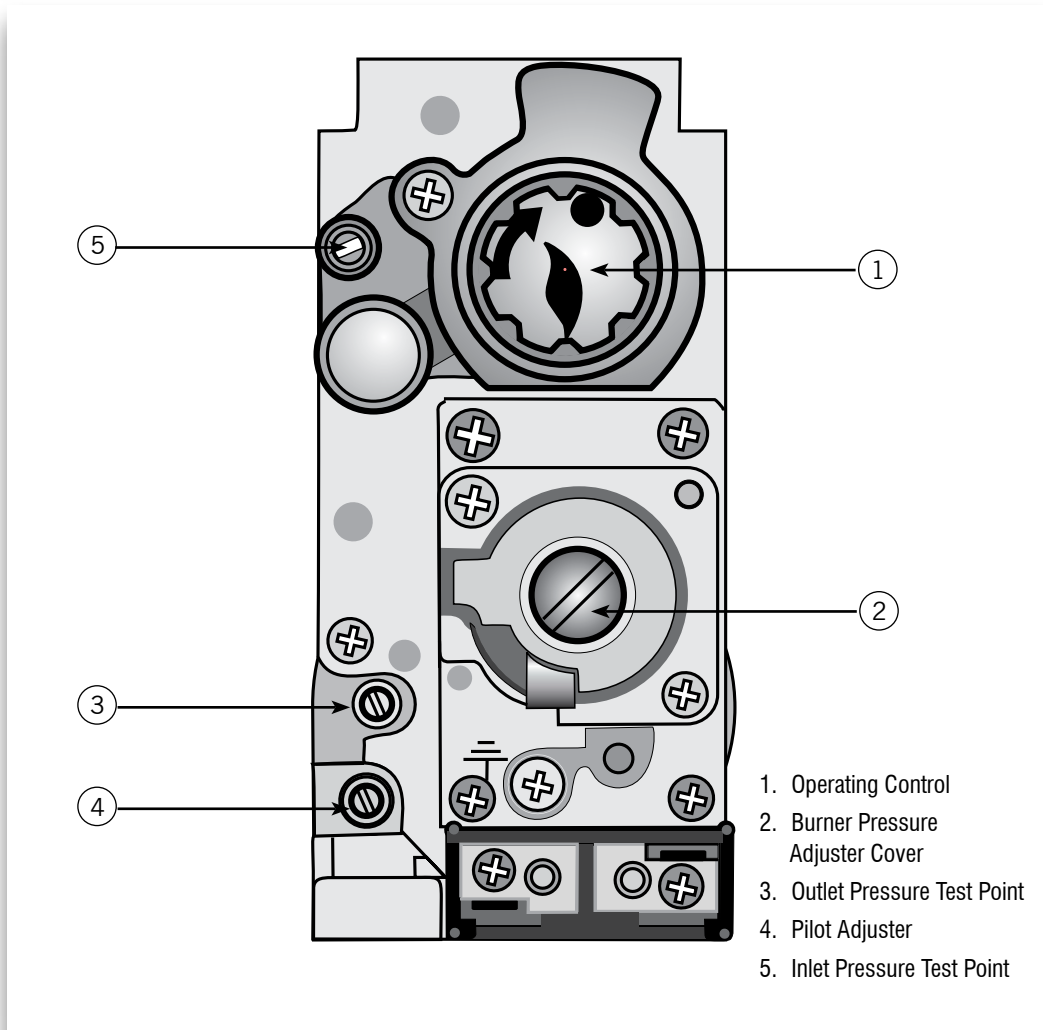

FIGURE 4. MULTIFUNCTIONAL CONTROL

7.5 EXTINGUISHING OF PILOT AND MAIN BURNERS

7.5.1 On the Multifunctional Control, rotate the OPERATING CONTROL clockwise to the '●' position and ensure that the OPERATING CONTROL fully resets, and both Pilot and Main Burners are extinguished.

7.5.2 On the Multifunctional Control, remove the pressure test gauge and secure the pressure test point screw.

7.6 TEMPERATURE RISE CHECKS

7.6.1 Ignite the Pilot and Main Burners and allow 15 minutes of operation for stability before continuing.

7.6.2 Check that the temperature rise across the heater is between 45°C - 55°C, setting the fan speed as follows:

i. **SYSTEM E-T HEATERS**

System E-T provides a fan speed corresponding to the above temperature rise, if the appliance is to be set to operate at the minimum rate and ducting has been sized accordingly, set the 'RATE SWITCH' to 'MIN', thus reducing the fan speed.

ii. **BASIC MODELS**

The fan speed is adjusted by selecting the fan speed at the control panel (decrease voltage selection to decrease the fan speed).

Note: Tapping 1 = 210V, Tapping 2 = 175V, Tapping 3 = 150V, Tapping 4 = 120V, Tapping 5 = 100V.

7.7 AUTOMATIC CONTROLS CHECK

7.7.1 Ignite the Pilot and Main Burners and allow to operate for 15 minutes to ensure stability.

7.7.2 Set the TIME CONTROL to 'ON'.

7.7.3 Turn the Thermista-stat or room thermostat slowly clockwise until the Main Burner ignites.

7.7.4 Ensure that the fan starts to operate after a short period (approx. 1-2 minutes).

SYSTEM E-T MODELS

7.7.5 Ensure that the fan speed increases to full speed.

7.7.6 When the temperature reaches the control setting, check that the Main Burner cycles ON and OFF, at approximately 75 to 120 seconds.

BASIC MODELS

7.7.7 When the temperature reaches the control setting, ensure that the Main Burner extinguishes followed by the fan switching off after a short period.

7.7.8 When the temperature falls below the control setting, ensure that the Main Burner re-ignites followed by fan operation.

7.8 SAFETY CHECKS

7.8.1 Check for gas soundness within the appliance.

7.8.2 **SPILLAGE TEST** - Carry out a full spillage test as follows, and ensure that the flue operates effectively with all doors closed and any extractor fans in operation.

NOTE: If an extractor fan is situated in an adjoining or adjacent room, carry out the spillage test with the interconnecting doors open.

If the draught diverter is accessible:

- a. Introduce smoke into the draught diverter adjacent to an exit from the heat exchanger, by means of a smoke match or puffer.
- b. Ensure that there is no spillage present (indicated by displacement of smoke downwards and out of the draught diverter).

If the Draught Diverter is not accessible:

- a. Introduce smoke, by means of **part** of a smoke pellet on a non-combustible support, into the heat exchanger.
- b. Extinguish the Main and Pilot burners.
- c. Ensure that there is no spillage evident by visually observing the draught diverter location on the air heater.
- d. If spillage is evident, further investigation and rectification is required before re-testing the appliance.
- e. **Repeat spillage tests but with the fan running, or Summer Airflow switch set to ON.**

WARNING: The appliance shall not be left connected to the gas supply unless it has successfully passed the above spillage test.

7.8.3 Turn OFF the gas supply at the service cock and ensure that the Multifunctional Control fail-safe operates within 60 seconds (indicated by loud click from Multifunctional Control).

7.8.4 Turn gas supply ON at service cock.

7.8.5 Switch the appliance electrical supply OFF.

7.8.6 Disconnect the Air Circulation Fan at the flying lead socket.

7.8.7 Switch the appliance electrical supply ON.

7.8.8 Ignite the Pilot and Main Burners as detailed in 7.3.1 to 7.3.5.

7.8.9 Ensure that the Limit Switch operates, indicated by the main burner extinguishing, within 120 and 180 seconds.

7.8.10 Switch the appliance electrical supply OFF.

7.8.11 Reconnect the Air Circulation Fan.

7.8.12 Switch the appliance electrical supply ON.

7.8.13 Ensure that the Main Burner re-ignites when the appliance temperature reduces, (note: with the Air Circulation Fan disconnected, there may be some delay before the Main Burner re-ignites).

	LOW RATE			MEDIUM RATE			HIGH RATE		
	kW	MJ/h	Btu/h	kW	MJ/h	Btu/h	kW	MJ/h	Btu/h
INPUT	10.40	37.4	35,500	11.4	41.0	38,900	12.5	45.0	42,640
OUTPUT	7.3	26.4	25,000	8.5	29.5	28,000	9.1	32.7	31,000
GAS RATE CV 1037 Btu/ft ³	0.98m ³ /h (34.5ft ³ /h)			1.06m ³ /h (37.5ft ³ /h)			1.16m ³ /h (41.1ft ³ /h)		
BURNER SETTING PRESSURE (HOT)	10.1mbar (4.0 in wg)			12.4mbar (5.0 in wg)			14.3mbar (5.7 in wg)		
MAIN INJECTOR	BRAY CAT 23/850								

TABLE 4. MAIN BURNER PRESSURE SETTINGS

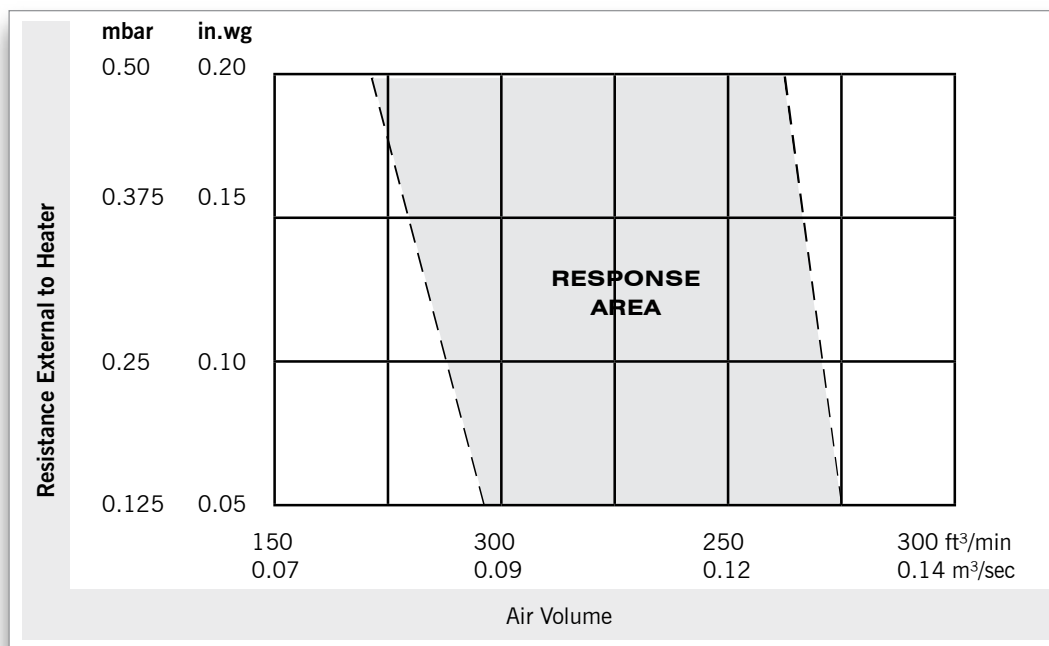

TABLE 5. FAN PERFORMANCE CURVE

8. INSTRUCTIONS FOR USER

- 8.1 If the building is unoccupied, ensure that the Instructions for User are left taped to the air heater for the User, and Installation Instructions are left at or near the air heater for use on future service calls.
- 8.2 If the building is occupied, hand the User Instructions over and ensure the User understands:
 - 8.2.1 How to ignite the Pilot and Main Burners.
 - 8.2.2 How to operate the Thermosta-stat/room thermostat, Time Control switch and SUMMER AIRFLOW switch, and that the Time Control must be reset following a power failure.
 - 8.2.3 How to extinguish the Pilot and Main Burner at the Multifunctional Control, and switch off the electrical supply to the heater.
 - 8.2.4 How to remove, clean and refit the air filter and at what intervals, (i.e., fortnightly, or weekly for new houses).
 - 8.2.5 How to control the heating system by opening and closing warm air outlets.
 - 8.2.6 How to obtain summer air circulation.
 - 8.2.7 That the air grilles on the heater or heater compartment; grilles and ventilators in the walls, windows or doors of the building **MUST NOT BE OBSTRUCTED**.
 - 8.2.8 That the heater must be serviced at least once a year by a competent person to ensure efficient and safe operation.
 - 8.2.9 That the red instructions for safe use have been pointed out and understood.
 - 8.2.10 That expert help must be obtained if persistent failure of the pilot burner occurs.

9. MAINTENANCE

IMPORTANT: Ensure that the gas and electricity supplies are isolated before commencing any maintenance or replacement of components. After completion of any maintenance, always test for gas soundness and carry out a complete functional test of the appliance in accordance with the Commissioning Instructions at Section 7.1 to 7.8 inclusive.

9.1 ROUTINE MAINTENANCE

- 9.1.1 Operate the appliance and check for the correct function of the burner and controls.
- 9.1.2 Turn OFF the gas and electrical supplies to the appliance.
- 9.1.3 Remove the air heater front panel.
- 9.1.4 Remove and check the return air filter/cleaner for cleanliness, remove and clean the Air Circulation fan as detailed in paragraph 9.8.
- 9.1.5 Remove the Burner and Controls Assembly as detailed in paragraph 9.2. Inspect and clean the main burner and injector as necessary. Examine the Main Burner for cracks, including hairline cracks, exchanging the burner as necessary.
- 9.1.6 Inspect and clear the pilot burner orifice.
- 9.1.7 Clean the heat exchanger flueways by thoroughly brushing from above and below.
- 9.1.8 By viewing through the Fan Aperture, and using a torch or similar, examine the heat exchanger externally signs for cracks or holes, particularly around welded joints.
- 9.1.9 Using a torch or similar, introduce a light source into the heat exchanger burner aperture and upper access-port, and again examine the heat exchanger for signs of cracks or holes, particularly around welded joints, whilst again viewing through the Fan Aperture.
- 9.1.10 Refit the Air Circulation fan, Burner and Controls Assembly, and air filter/air cleaner.
- 9.1.11 Light the appliance and note the main burner flame profile. If the flame profile is affected when the Air Circulation Fan switches on, check for any air leaks between the air heater and the base plenum, paying particular attention to heaters with rear draught diverters. Rectify any air leaks before continuing with this procedure.
- 9.1.12 Allow the air heater to operate for approximately 15 minutes to ensure stability, and with the main burner lit, ensure that the operation of Air Circulation fan does not affect the main burner flame profile.
- 9.1.13 If no defects are found, fully commission the air heater in accordance with the Installation, Commissioning and maintenance Instructions applicable to the appliance.

9.2 BURNER AND CONTROL ASSEMBLY REMOVAL

- 9.2.1 Ensure that the Gas and Electrical supplies are switched OFF
- 9.2.2 Remove the appliance louvre door.
- 9.2.3 Disconnect the igniter at the Piezo unit.
- 9.2.4 Disconnect the Multifunctional Control electrical connections.
- 9.2.5 Disconnect the gas supply by breaking the union at the input side of the Multifunctional Control.
- 9.2.6 Release the 2 x burner assembly fixing screws and withdraw the Burner and Control Assembly
- 9.2.7 Refit the Burner and Control Assembly in reverse order.

9.3 BURNER AND CONTROL ASSEMBLY CLEANING

- 9.3.1 Remove the Burner and Controls Assembly as detailed in paragraph 9.2.
- 9.3.2 Disconnect the Pilot Feed Pipe from the Multifunctional Control.
- 9.3.3 Release the nut and washer securing the Pilot Assembly to the Burner and Controls Assembly, and withdrawn the Pilot Assembly.
- 9.3.4 Release the screws securing the Main Burner to the mounting bracket, and withdraw the Main Burner.
- 9.3.5 Clean the burner thoroughly both inside and out with a soft brush. **DO NOT ENLARGE, DISTORT OR DAMAGE BURNER HOLES.**
- 9.3.6 Reassemble in reverse order.

9.4 MAIN INJECTOR REMOVAL, CLEANING AND REPLACEMENT

- 9.4.1 Remove the Burner and Control Assembly as detailed in paragraph 9.2.
- 9.4.2 Unscrew the main injector from the housing.
- 9.4.3 Clean as necessary. **DO NOT ENLARGE, DISTORT OR DAMAGE THE MAIN INJECTOR HOLE.**
- 9.4.4 If the injector is to be replaced, ensure that it is correctly marked, referring to the data badge for details.
- 9.4.5 Refitment or replacement is in reverse order.

9.5 PILOT BURNER, THERMOCOUPLE AND ELECTRODE, REMOVAL AND REPLACEMENT

- 9.5.1 Remove the Burner and Controls Assembly as detailed in paragraph 9.2
- 9.5.2 Disconnect the Igniter lead from the Electrode.
- 9.5.3 Release the Pilot Feed Pipe from the pilot injector.
- 8.5.4 Release the retaining nut and withdraw the Thermocouple from the Pilot Burner Assembly, taking care to avoid causing damage to the capillary.

- 8.5.5 Release the Electrode securing nut from the Pilot Burner Assembly and withdraw the Electrode.
- 8.5.6 Release the two screws securing the Pilot Burner Assembly to the Main Burner, and remove the Pilot Burner Assembly.
- 8.5.7 Refitting or replacement is in reverse order.

NOTE: When refitting or replacing Thermocouple, tighten only to FINGER TIGHT + 1 FLAT.

9.6 MULTIFUNCTIONAL CONTROL REMOVAL

- 9.6.1 Remove the Burner and Controls Assembly as detailed in 9.2
- 9.6.2 Disconnect the Thermocouple at the Multifunctional Control, avoiding damage to the capillary.
- 9.6.3 Disconnect the Pilot Feed Pipe from the Multifunctional Control.
- 9.6.4 Disconnect the Multifunctional Control input and output supply feeds.
- 9.6.5 Refitting or replacement is in reverse order.

NOTE: When refitting or replacing the Multifunctional Control, the 'O' ring seal is to be replaced.

9.7 PIEZO UNIT REMOVAL

- 9.7.1 Disconnect the 2 conductors from Piezo unit.
- 9.7.2 Release the retaining nut and remove the Piezo unit from its mounting bracket.
- 9.7.3 Refitting or replacement is in reverse order.

9.8 AIR CIRCULATING FAN, REMOVAL AND CLEANING

- 9.8.1 Ensure that the electrical supply is isolated.
- 9.8.2 Remove the appliance louvre door, release the securing screws and hinge down the fan chamber door.
- 9.8.3 Disconnect the fan flying leads from the Fan Assembly.
- 9.8.4 Release the Fan Assembly securing screw and withdraw the Fan Assembly from the Heater cabinet, avoiding damage to the fan blades.
- 9.8.5 Remove all dust from both the impeller and motor, taking care to not disturb the balance of the fan.
- 9.8.6 Refitting or replacement is in reverse order.

9.9 ELECTRICAL ASSEMBLY REMOVAL

- 9.9.1 Ensure that the electrical supply is isolated.
- 9.9.2 Remove the appliance louvre door, release the securing screws and hinge down the fan chamber door.

SYSTEM E-T MODELS

- 9.9.3 Disconnect the following
 - a. Air circulation fan flying leads from the capacitor,
 - b. 230V mains 'L', 'N' and 'E' from connection block terminals '1' and '2', and **Earth stud** respectively,
 - c. Thermosta-stat connections from connection block terminals '7' and '8',
 - d. Limit Switch from connection block terminals '13' and '14',
 - e. Fan Delay Control from connection block terminals '18' and '17',
 - f. Multifunctional Control from connection block terminals '16' (N) and '15' (L),
 - g. Water heater from connection block terminals '10' (L) and '9' (N),
 - h. Water Pump from connection block terminals '12' (L) and '11' (N),
 - i. Cleanflow from connection block terminals '19' (24V) and '20' (0V),
 - j. Earth lead from the fan chamber floor,

BASIC MODELS

- 9.9.4 Disconnect the following:
 - a. Air circulation fan flying leads from the Fan assembly,
 - b. 230V mains 'L', 'N' and 'E' from connection block terminals '1' and '2', and **Earth stud** respectively,
 - c. Room thermostat connections from connection block terminals '7' and '8',
 - d. Limit Switch from connection block terminals '13' and '14',
 - e. Fan Delay Control from connection block terminals '18' and '17',
 - f. Multifunctional Control from connection block terminals '16' (N) and '15' (L),
 - g. Water heater from connection block terminals '10' (L) and '9' (N),
 - h. Water Pump from connection block terminals '12' (L) and '11' (N),
 - i. Cleanflow from connection block terminals '19' (24V) and '20' (0V),
 - j. Earth lead from the fan chamber floor,

BOTH MODEL TYPES

- 9.9.5 Disconnect the 2 x Spillage monitor connections from the terminal block terminal '15', and the relay module 'COMM' terminal.
- 9.9.6 Release the 2 x screws from the hinged access door and withdraw the Electrical assembly, releasing wiring from cable clamps and grommets as required..
- 9.9.7 Refitting or replacement is in reverse order.

9.10 ELECTRONIC MODULE REMOVAL (SYSTEM E-T models only)

- 9.10.1 Ensure that the electrical supply is isolated.
- 9.10.2 Remove the appliance louvre door, release the securing screws and hinge down the fan chamber door.
- 9.10.3 Disconnect terminals '21' through to '33' from the Electronic module.
- 9.10.4 Release the 2 x screws and nuts securing Electronic module to Electrical Assembly and remove module.
- 9.10.5 Refitting or replacement is in reverse order.

9.11 TRANSFORMER REMOVAL (BASIC models only)

- 9.11.1 Ensure that the electrical supply is isolated.
- 9.11.2 Remove the appliance louvre door, release the securing screws and hinge down the fan chamber door.
- 9.11.3 Disconnect the conductors from the transformer.
- 9.11.4 Release the 2 x screws and nuts securing the Transformer to the Electrical Assembly, and remove the Transformer.
- 9.11.5 Refitting or replacement is in reverse order.

9.12 TIME CONTROL and SWITCH REMOVAL

- 9.12.1 Ensure that the electrical supply is isolated.
- 9.12.2 Remove the appliance louvre door, release the securing screws and hinge down the fan chamber door.

TIME CONTROL REMOVAL

- 9.12.3 Disconnect conductors 'C1', 'C2', 'C3' and 'C5' from the Time Control.
- 9.12.4 Release the 2 x fixing screws, and withdraw the Time Control.
- 9.12.5 Refitting or replacement is in reverse order.
- 9.12.6 Set the Time Control to required ON and OFF times.
- 9.12.7 Set the Time Control to correct time.

SWITCH REMOVAL

- 9.12.8 Disconnect the conductors from the switch terminals.
- 9.12.9 Depress the retaining clips and press the switch out of the fascia panel.
- 9.12.10 Refitting or replacement is in reverse order.

WARNING: The fascia panel is held in place by push fit retainers which must be removed with caution to avoid causing damage to the support pins. Removal of the fascia is not advised unless it is intended to be replaced.

9.13 FAN DELAY CONTROL/LIMIT SWITCH REMOVAL

- 9.13.1 Ensure that the electrical supply is isolated.
- 9.13.2 Remove the appliance louvre door, release the securing screws and hinge down the fan chamber door.
- 9.13.3 Disconnect the following at the Electrical panel:
 - a. Limit Switch from connection block terminals '13' and '14',
 - b. Fan Delay Control from connection block terminals '18' and '17',
 - c. Earth connection from common earth stud.
- 9.13.4 Release the 2 x 4mm screws securing the Limit switch mounting plate, and withdraw the control from the appliance by drawing the conductors through the grommet in the fan chamber floor.
- 9.13.6 Refitting or replacement is in reverse order.

9.14 SPILLAGE MONITORING DEVICE (TTB) REMOVAL

- 9.14.1 Ensure that the electrical supply is isolated.
- 9.14.2 Remove the appliance louvre door, release the 2 x securing screws and hinge down the fan chamber door.
- 9.14.3 Disconnect the TTB from its conductors.
- 9.14.4 Release the 2 x screws securing the TTB Bracket to the fan chamber floor, and withdraw the TTB Bracket.
- 9.14.5 Refitting or replacement is in reverse order.

9.15 HEAT EXCHANGER ACCESS

- 9.15.1 Remove the Burner and Controls assembly as detailed in 9.2.
- 9.15.2 Release the 4 x screws securing the heat shield, and withdraw the heat shield.
- 9.15.3 Release the 2 x screws securing the heat exchanger access cover plate, and withdraw the cover plate and gasket.
- 9.15.4 The heat exchanger may now be inspected and brushed through.

IMPORTANT: When reassembling, ensure that the gasket is soundly sealed. Re-commission the air heater as detailed in Section 7.

10. DEFECT DIAGNOSIS

10.1 IMPORTANT

If an electrical defect occurs after installation of the appliance; preliminary earth continuity, polarity and resistance to earth checks should be carried out with a multi-meter. On completion of any maintenance/fault finding task that has required the breaking and remaking of electrical connections, then checks of continuity, polarity, and resistance to earth must be repeated.

10.2 WARNINGS

10.2.1 When purging or checking gas supplies, ensure that ventilation to the room or cupboard is adequate, and that all naked lights are extinguished.

10.2.2 SYSTEM E-T MODELS

- a. When carrying out any electrical testing, a test meter MUST be used, since low resistance test devices can cause damage to the Electronics module.
- b. Before commencing defect diagnosis, ensure that the Thermista-stat is set to maximum, mains supply is 'ON' and the time control (if fitted) is at an 'ON' position.
- c. Care is to be taken during the replacement and handling of electronic assemblies (i.e. electronic panel, airflow sensor or Thermista-stat). It is not practical to rectify defects on these assemblies, except at the manufacturer, and any attempt to do so may render the guarantee or factory replacement arrangement invalid.

10.3 THE SYSTEM E-T MODULE

The SYSTEM E-T module is fitted with a diagnostic light emitting diode (LED) which is visible through a hole in the module cover, as shown in Figure 5 below. If the LED is flashing, this means that :

- 10.3.1 The fan is not connected, or
- 10.3.2 The capacitor is not connected, or
- 10.3.3 There is a short circuit in the fan supply.

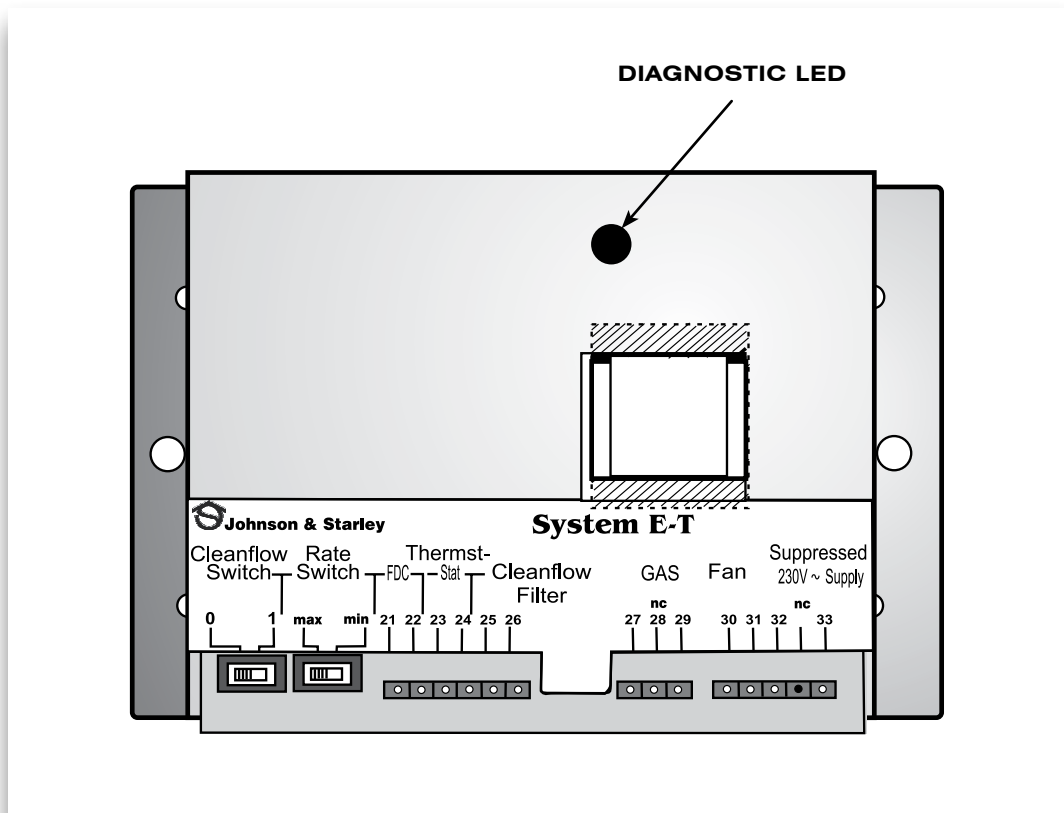

FIGURE 5. SYSTEM E-T ELECTRONIC MODULE

DEFECT DIAGNOSIS

	SYMPTOM	POSSIBLE CAUSE	REMEDY
1	Pilot will not light	No gas supply to heater	Check for gas at inlet pressure test point on Multifunctional Control
		Gas supply pipe not purged	Purge gas supply pipe in accordance with BS 6891
		Pilot orifice restricted	Clear pilot orifice or replace pilot injector
		Piezo system faulty	Check igniter, lead and electrode
		Excessive gas supply pressure	Check that mains gas pressure is 20mbar and reduce if necessary
2	Pilot lights but goes out on releasing START button during initial light-up, or after normal operation	Connection between Thermocouple and Multifunctional Control not secure	Check connection is secure
		Faulty Multifunctional Control	Replace Multifunctional Control
		Faulty Thermocouple	Replace Thermocouple
3	Main burner operating intermittently with fan running	Gas rate or burner pressure setting high	Check gas rate and burner pressure setting
		Temperature rise excessive	Adjust fan speed or gas rate accordingly
		Air filter or return air path restricted	Check filter is clean and air path is clear
		Excessive number of outlets closed	Open additional outlets
		Spillage of flue gases	Carry out spillage test and rectify
		Spillage monitor device (TTB) faulty	Replace Spillage device (TTB)
SYSTEM E-T Models			
4	Incorrect operation of fan or main burner	Fault related to SYSTEM E-T control System (refer to pages 20-25)	Consult diagnostic chart and follow recommended procedure
BASIC Models			
5	Pilot alight but main burner not igniting	Mains electrical supply not connected to heater	Check Mains supply
		Controls not demanding heat	Check that time control and room thermostat are operating correctly
		T3.15A Fuse failed	Replace. If failure occurs again, check wiring for short circuits
		Loose connection to room thermostat, limit switch, gas control lead, time control or transformer	Check connections
		230V/24V Transformer failure	Check 24V side with test meter, if voltage missing, replace transformer
		Faulty relay module	Check 24V at white wire from switch S5
		Multifunctional Control faulty	Replace Multifunctional Control
		Limit switch faulty	Short circuit control and replace if necessary
		Room thermostat or external wiring faulty	Fit temporary loop in heater thermostat socket. If heater ignites, external circuit or room thermostat is faulty
		Spillage device faulty	Check spillage device and wiring for open circuit

	SYMPTOM	POSSIBLE CAUSE	REMEDY
6	Mains burner lights but fails to run after approx. 3 minutes	Loose electrical connection at Fan Delay Control	Check connections
		Fan Delay Control faulty	Replace
		Faulty fan assembly	Replace, taking care not to damage impellor
		Burner pressure setting incorrect	Adjust pressure as necessary
7	Main burner operating with intermittent fan operation	Gas rate or burner pressure setting too low	Check gas rate and burner pressure setting
		Fan Delay Control faulty	Replace
8	Noisy Operation	Gas pressure too high	Check burner pressure setting
		Noisy fan motor	Replace fan assembly
		Fan speed setting too high	Adjust fan speed
9	Fan runs for excessive periods or operates intermittently after main burner shuts down	Fan Delay Control faulty	Replace

11. SYSTEM E-T DEFECT DIAGNOSIS FLOW CHART

MAIN BURNER NOT CYCLING (ROOM TEMPERATURE TOO HIGH)

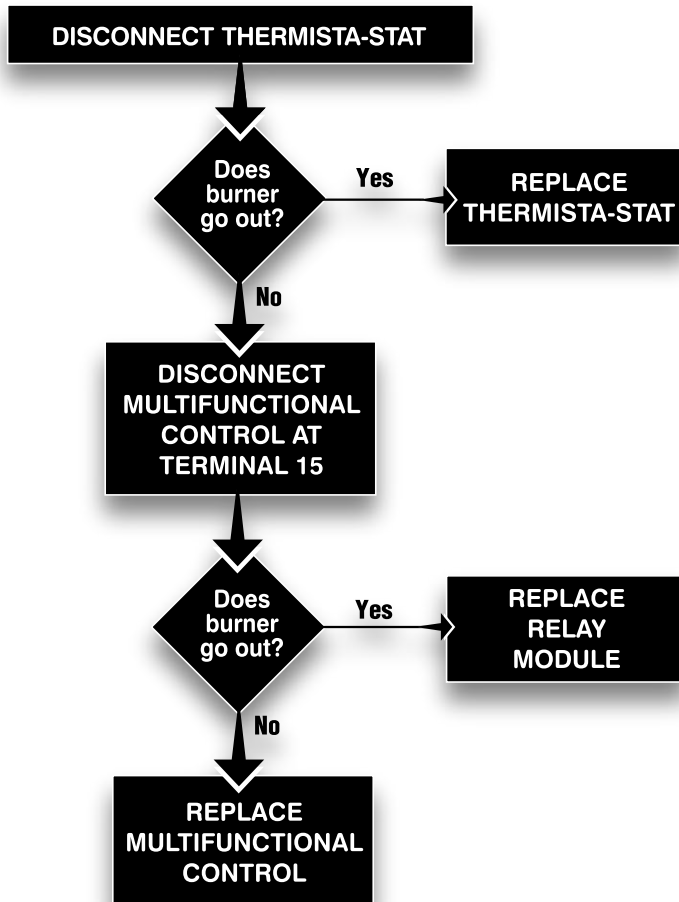

MAIN BURNER ON, BUT FAN NOT RUNNING

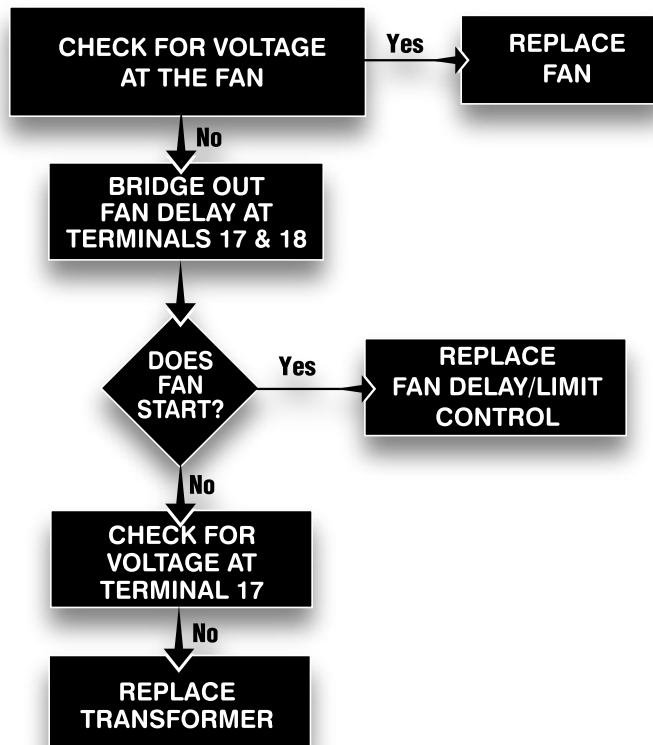

FAN OPERATES. BUT BURNER CYCLES BEFORE REQUIRED TEMPERATURE IS REACHED

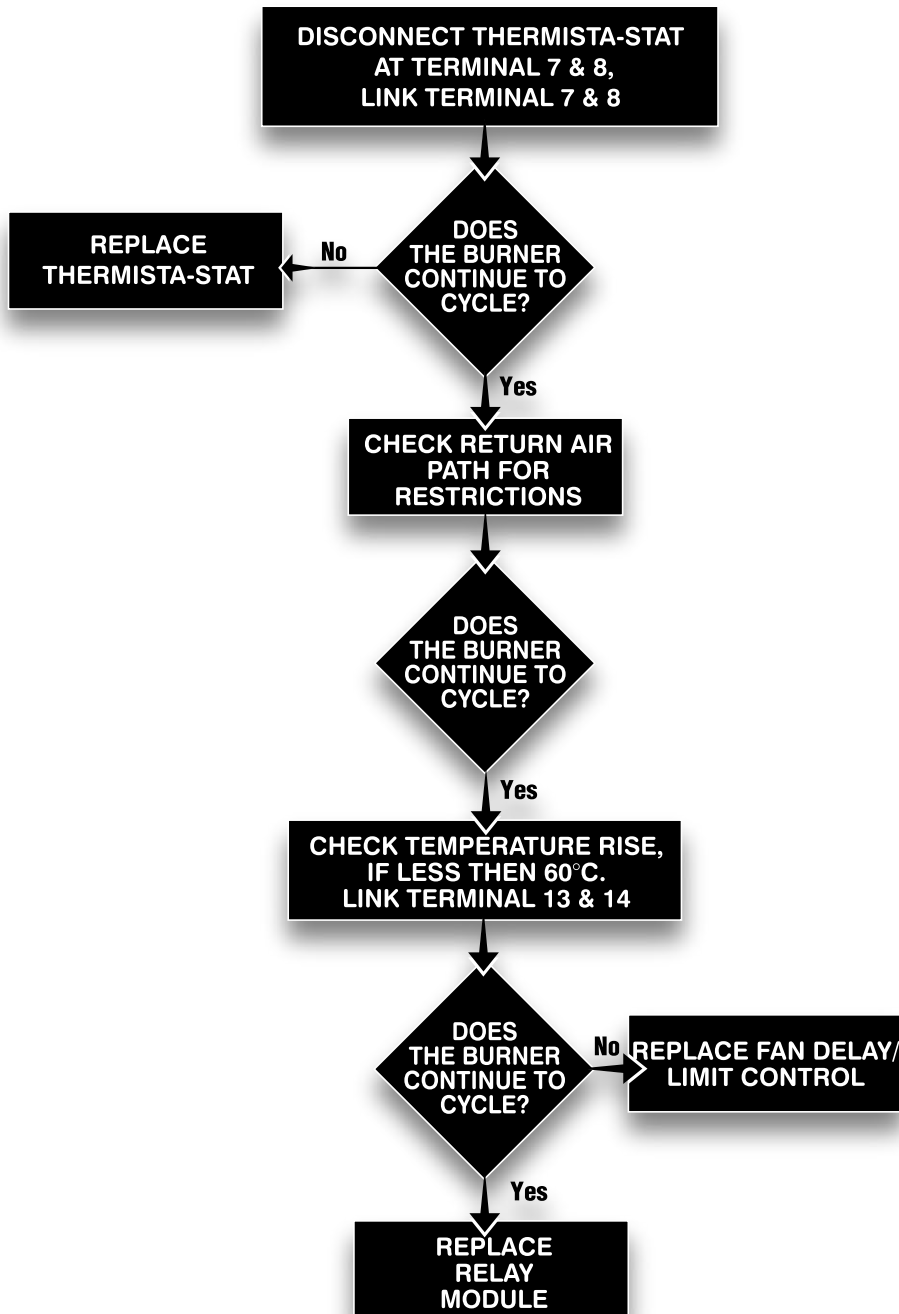

FAN CONTINUES RUNNING, OR CYCLES AFTER HEATING IS TURNED OFF

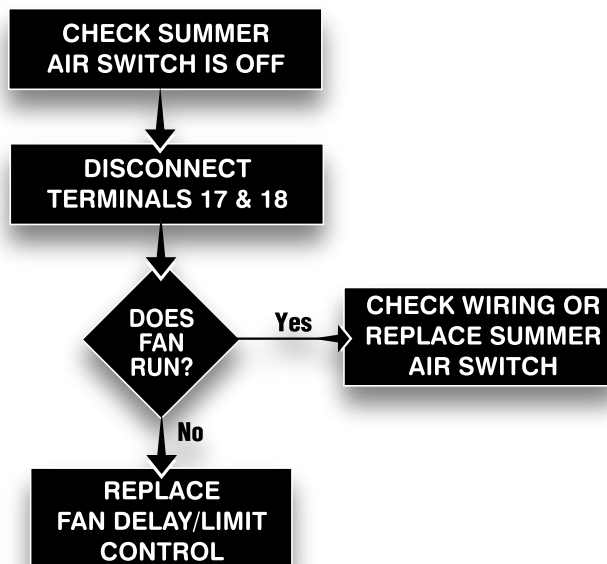

FAN RUNS BUT MAIN BURNER NOT OPERATING

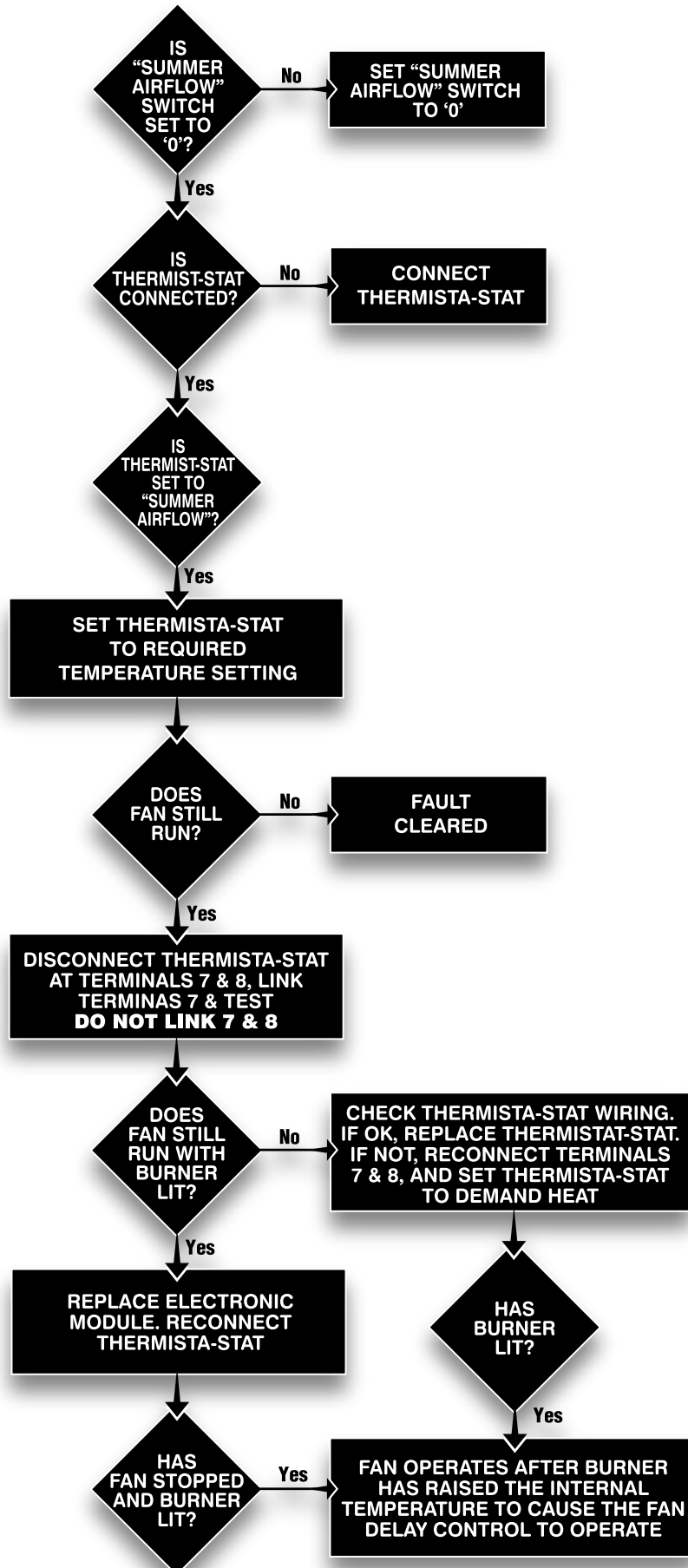

MAIN BURNER NOT OPERATING

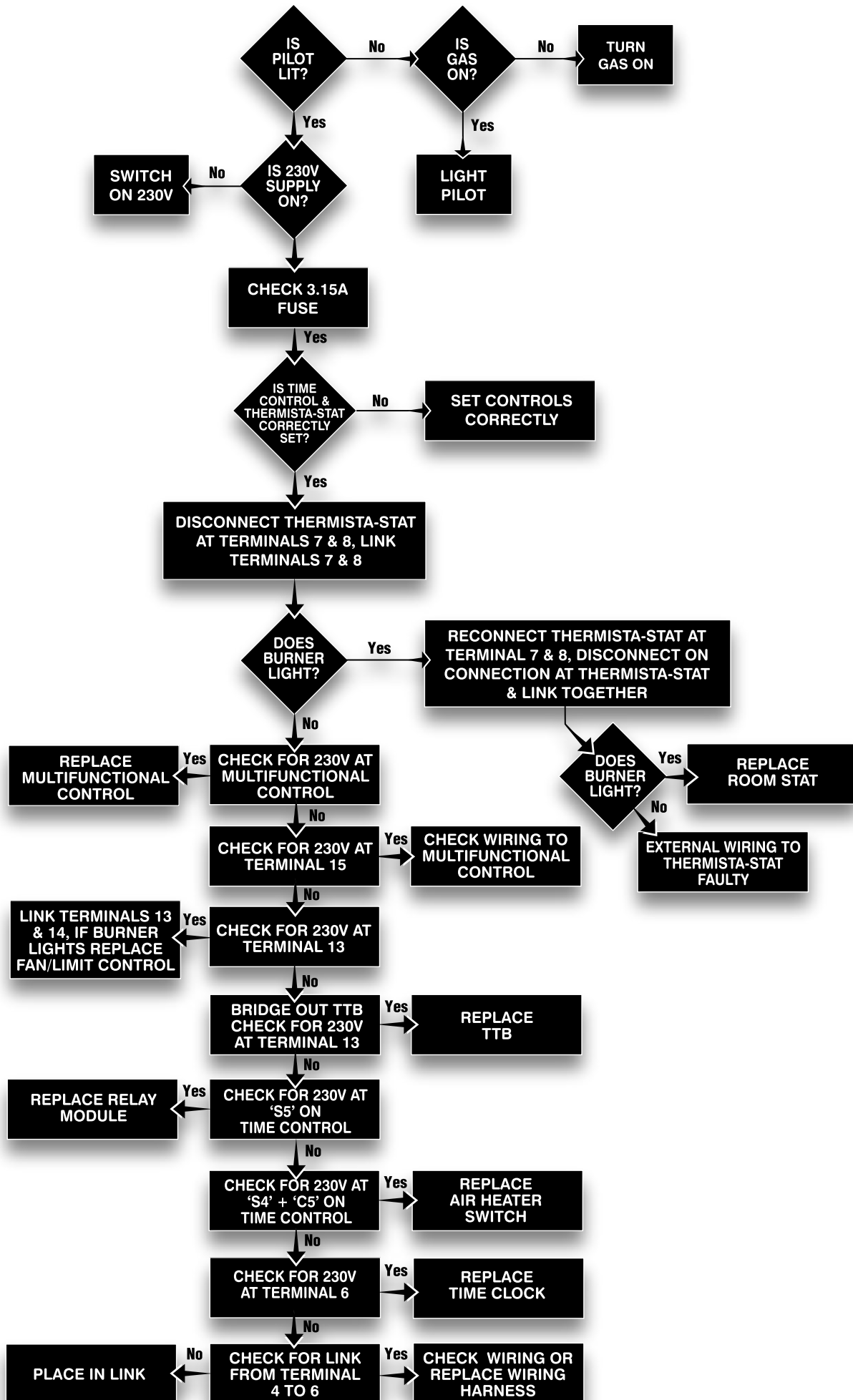

12. CIRCUIT DIAGRAMS

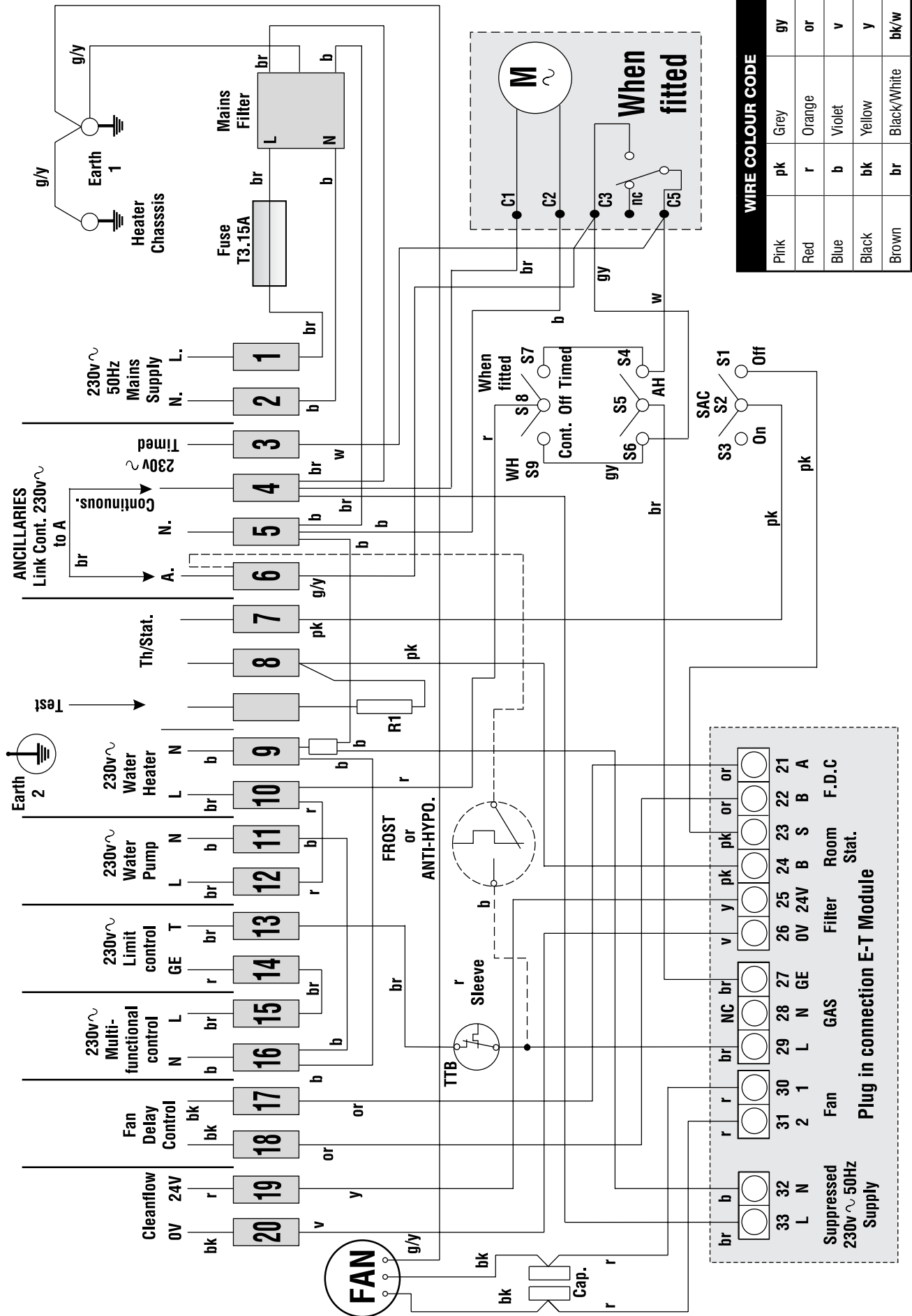

FIGURE 6a. HI-SPEC M31 SYSTEM E-T CIRCUIT DIAGRAM

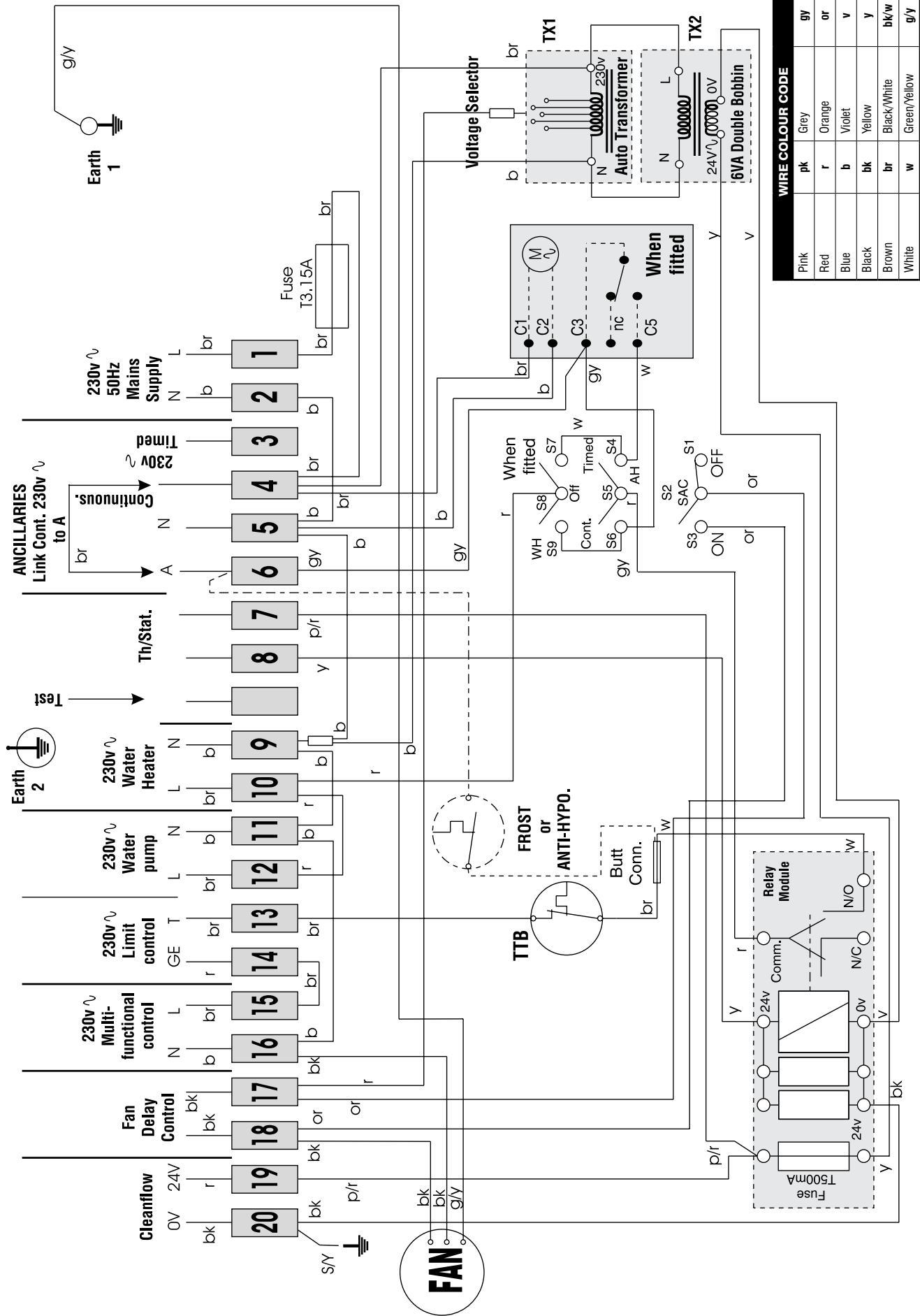
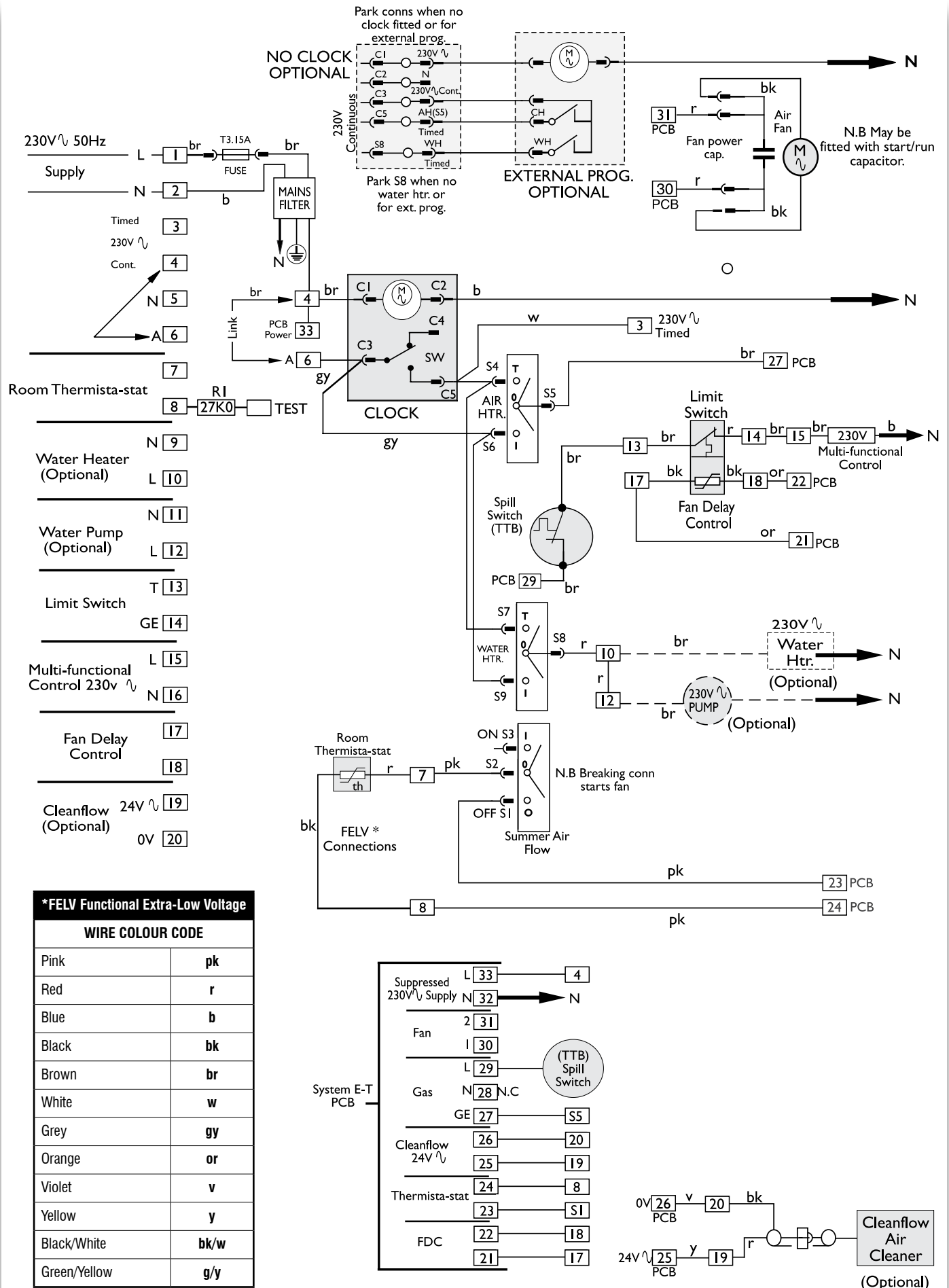

FIGURE 6b. HI-SPEC M31 BASIC MODEL CIRCUIT DIAGRAM

13. FUNCTIONAL DIAGRAMS



***FELV Functional Extra-Low Voltage**

WIRE COLOUR CODE	
Pink	pk
Red	r
Blue	b
Black	bk
Brown	br
White	w
Grey	gy
Orange	or
Violet	v
Yellow	y
Black/White	bk/w
Green/Yellow	g/y

FIGURE 7a. HI-SPEC M31 SYSTEM E-T FUNCTIONAL DIAGRAM

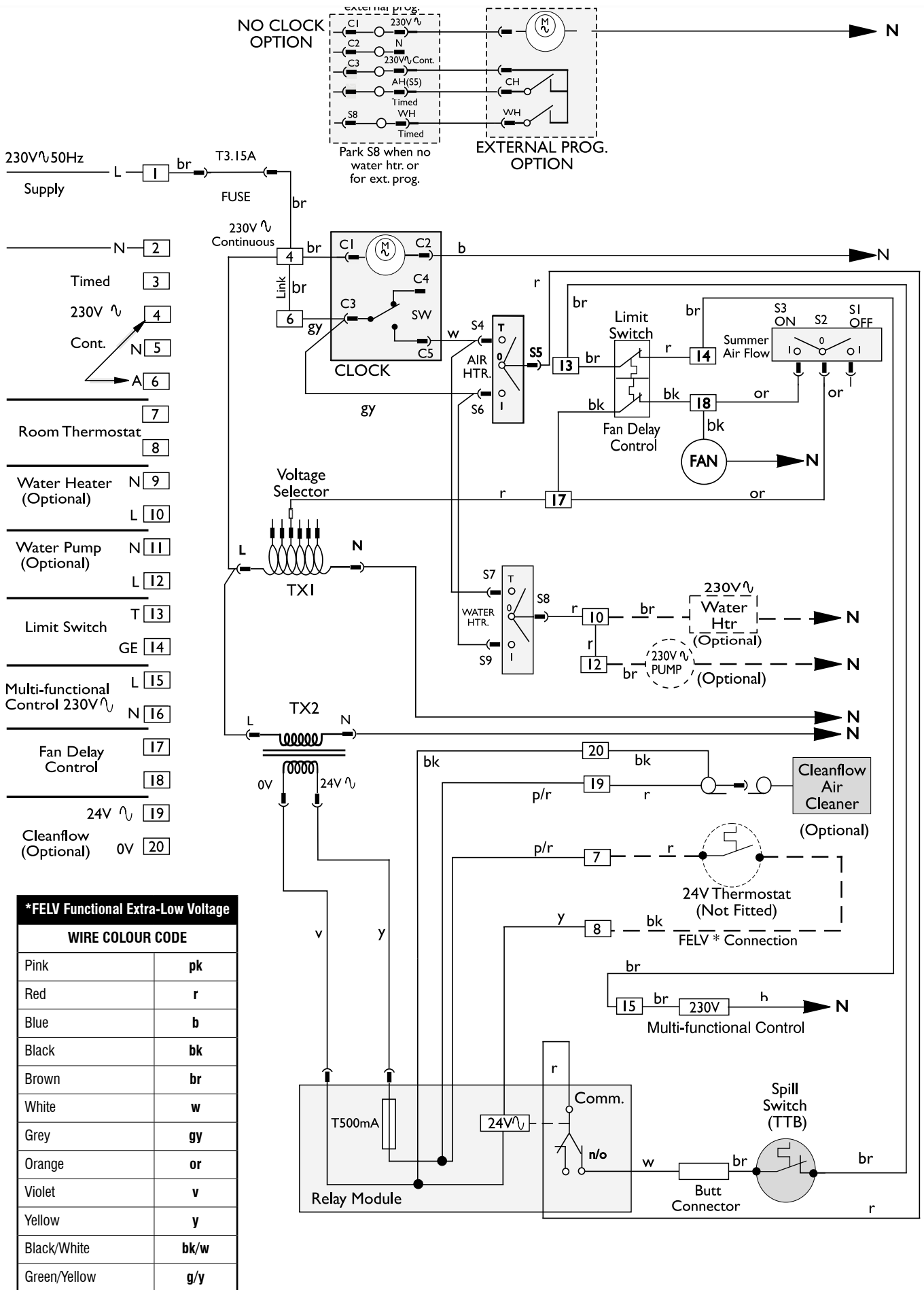

FIGURE 7b. HI-SPEC M31 BASIC MODEL FUNCTIONAL DIAGRAM

14. LIST OF SPARES

REFER TO THE EXPLODED DIAGRAM (Figure 8)

ITEM	G.C. No.	PART No.	DESCRIPTION	QTY
1	E76429	1000-0500375	Fan Assembly	1
2		1000-0701130	Multifunctional Control (Honeywell) from serial No. 13010001	1
3	232 903	BOS 02061	'O' Ring Seal	2
5	245 183	1000-0703150	Pilot Injector No. 38 from serial No. 13010001	1
6		1000-0709160	Pilot Body	1
7		1000-0701530	Pilot Feed Pipe from serial No. 13010001	1
8		1000-0704890	Hooked Nut 4mm from serial No. 13010001	1
9		1000-0704900	Hooked Olive 4mm from serial No. 13010001	1
10		1000-0709690	Igniter Electrode with integral lead from serial No. 13010001	1
11	397 819	BOS 02394	Igniter Lead	1
12	395 754	BOS 00036	Thermocouple from serial No. 13010001	1
13	378 466	BOS 02031	Time Control	1
14		M302-0765000	Burner and Control Assembly from Serial No. 13010001	1
15	245 505	1000-0704480	Main Burner Arm	1
16	398 353	208S711	Main injector (Bray 23/850)	1
17	395 945	1000-0700570	Piezo Unit (High Energy)	1
18	245 509	1000-0513820	Fuse T3/15A Anti-surge	1
19		M302-018400	Filter Tray	1
20	245 395	1000-3001320	Door strike	1
21	245 036	B300-0300005	Heat Exchanger	1
22	245 542	1000-0515970	Capacitor 15 uF	1
23	245 188	1000-0516325	Honeywell Roomstat	1
24	386 634	1000-0503730	Spillage Monitor Device (TTB) From Serial No. 13009650	1
SYSTEM E-T MODELS ONLY				
25	245 512	ET003	Electronic Panel Assembly with daughter board	1
26	245 514	1000-0515620	Thermista-stat	1
27	245 515	1000-0515455	Fan delay Control/Limit Switch	1
28	E05328	1000-0515090	Mains Filter	1
29	E77438	M302-0504000	Complete Electrical Panel	1
30	E77505	M302-0157000	Cabinet Door Assembly	1
BASIC MODELS ONLY				
31	245 517	1000-0505770	Electrical Panel	1
32	245 520	1000-0516125	Fan Delay Control/Limit Switch	1
33	245 522	1000-0505190	Transformer Fan Speed	1
34	245 525	1000-0515730	Transformer 24 Volt	1
35	245 413	1000-0511760	Relay Module	1
36	E77504	M302-0158000	Cabinet door Assembly	1
37	245 423	1000-0502240	Fuse 500mA Anti-Surge	1
CLEANFLOW AIR CLEANER (Optional Extra)				
38	E05565	M302-0681000	Electronic Air Cleaner	1
39	E77436	A0280X0759	Cleanflow Filter Pads	1
40	E69656	1000-0505540	Cleanflow Electronic Box	2

15. EXPLODED DIAGRAM

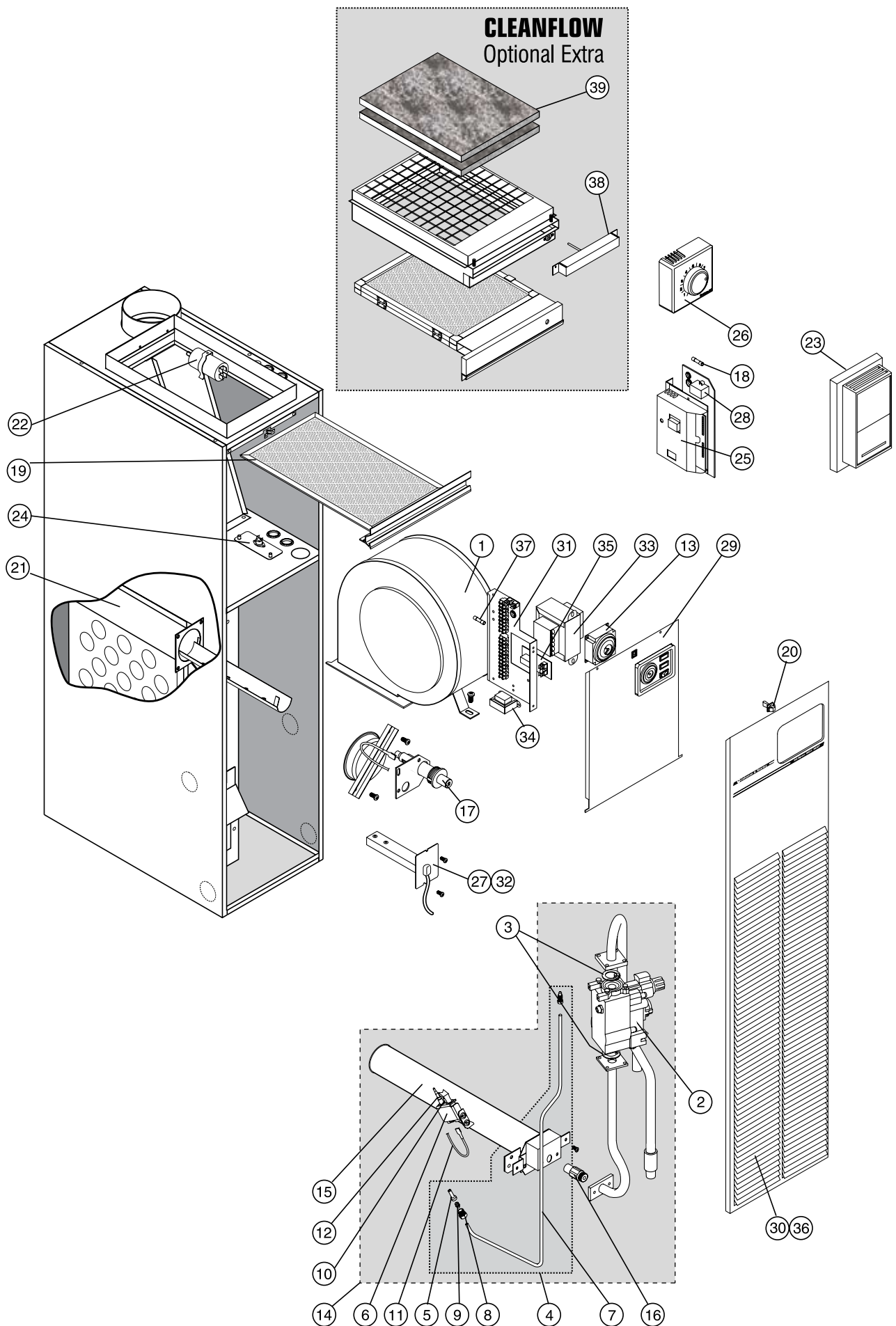

FIGURE 8. HI-SPEC M31 EXPLODED DIAGRAM

16. DIMENSIONS

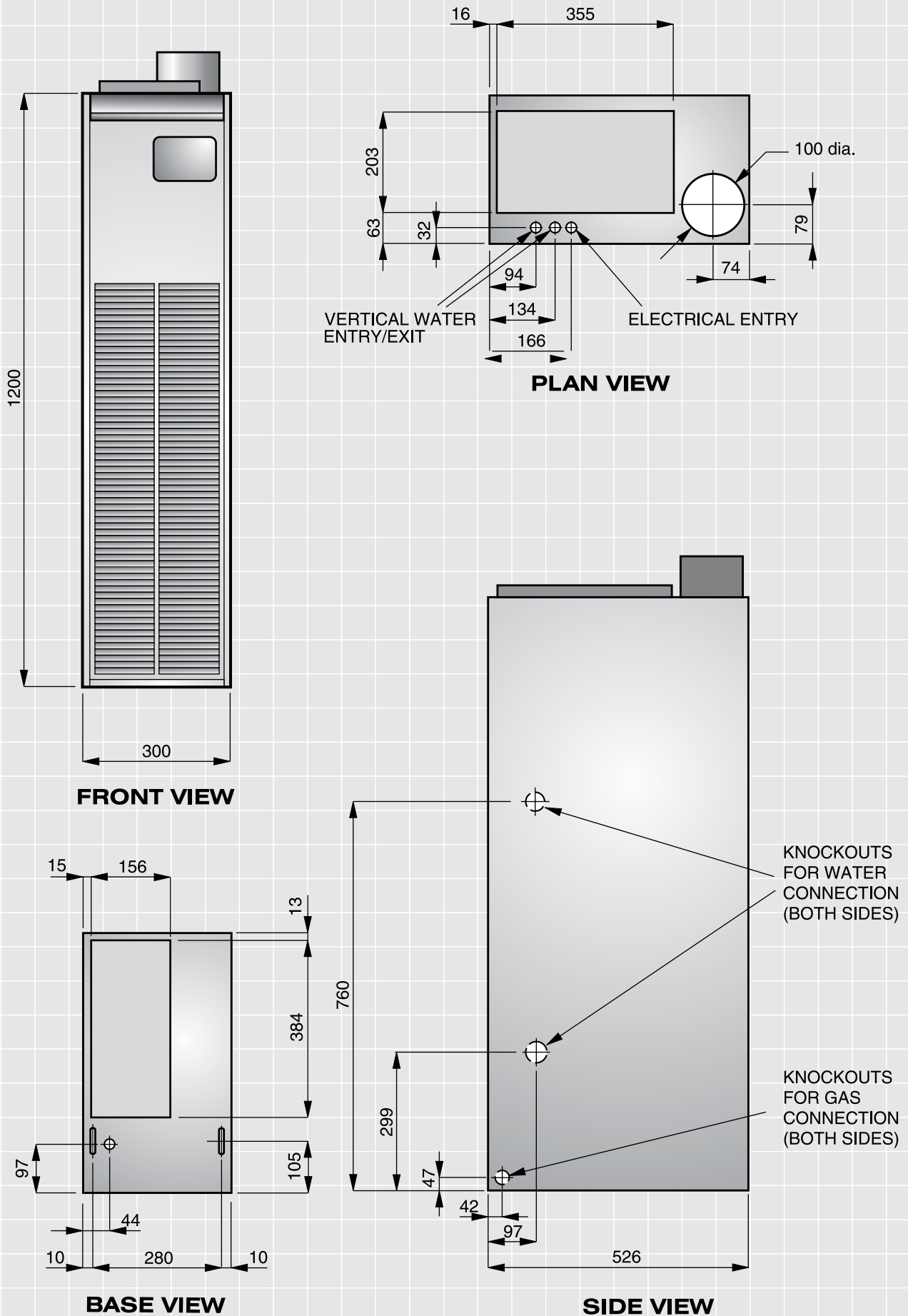
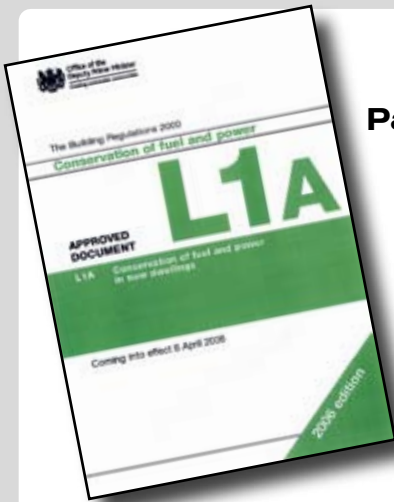
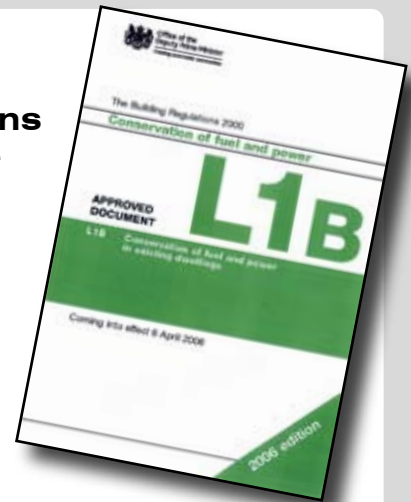

FIGURE 9. HI-SPEC M31 DIMENSIONS

IMPORTANT INFORMATION



Warm Air Heating
Fully complies with
Part L of the Building Regulations
by following the guidance in the
British Standard BS 5864
and the
Heating Compliance Guide
For further information contact
Johnson & Starley
on Telephone: 01604 762881



These kits are readily available from Johnson & Starley Ltd
Telephone the Sales Office for further information

HI-SPEC M31 ANCILLARY'S		
	Description	Product Code
1	Cleanflow Air Filter	CFM31H
2	Return Air Plenums	RAP31M
3	Return Air Kits	RAK31M
4	Slot Fix Panels	TS31M/TSG31M
5	Top Closure Panels	TP31M/TC31M B4530 (RISER)
6	Base Duct	WB31M
7	Flow/Return Kit	FMR31M
ELJAN 6S WATER HEATER KIT ANCILLARY'S		
7	Flow/Return Kit	FMR31M



HI-SPEC M31 LOG BOOK

WARM AIR HEATER AND CIRCULATOR COMMISSIONING CHECKLIST



This Log Book should be filled out at each
annual service

WARM AIR HEATER AND CIRCULATOR COMMISSIONING CHECKLIST

This Commissioning Checklist is to be completed in full by the competent person who commissioned the warm air unit and associated equipment as a means of demonstrating compliance with the appropriate Building Regulations and then handed to the customer to keep for future reference.

Failure to install and commission this equipment to the manufacturer's instructions may invalidate the warranty but does not affect statutory rights.

Customer Name _____
 Address _____
 Telephone Number _____
 Warm Air Unit Make and Model _____
 Warm Air Unit Serial Number _____
 Commissioned by (print name) _____ Gas Safe Reg. No. _____
 Company Name _____ Telephone No. _____
 Company Address _____
 Commissioning Date _____

To be completed by the customer on receipt of a Building Regulations Compliance Certificate*:

Building Regulations Notification Number (if applicable) _____

CONTROLS Tick the appropriate boxes if applicable

Time & Temperature Control to Heating	Room Thermostat & Programmer/Timer <input type="checkbox"/>	Programmable Roomstat <input type="checkbox"/>	Load/Weather Compensation <input type="checkbox"/>	Optimum Start Control <input type="checkbox"/>
Time & Temperature Control to Hot Water			Cylinder Thermostat & Programmer/Timer <input type="checkbox"/>	Warm Air Unit <input type="checkbox"/>
Heating Zone Valves			Fitted <input type="checkbox"/>	Not Required <input type="checkbox"/>
Hot Water Zone Valves			Fitted <input type="checkbox"/>	Not Required <input type="checkbox"/>
Thermostatic Radiator Valves			Fitted <input type="checkbox"/>	Not Required <input type="checkbox"/>
Automatic Bypass System			Fitted <input type="checkbox"/>	Not Required <input type="checkbox"/>
Warm Air Unit Interlock			Yes <input type="checkbox"/> No <input type="checkbox"/> If YES, Volume _____ Litres	

FOR WARM AIR HEATERS ONLY

Has the system been balanced in accordance with the heater manufacture's instructions? Yes No
 Was an anemometer used? Yes No
 Have balancing dampers been fitted? Yes No

FOR WARM AIR HEATING: MEASURE AND RECORD

Burner operating pressure _____ mbar
 Heat input _____ kW
 Temperature difference between return air inlet and nearest outlet _____ °C

FOR HOT WATER GENERATORS: MEASURE AND RECORD

Burner operating pressure _____ mbar
 Heat input _____ kW
 Water flow temperature _____ °C

ALL INSTALLATIONS

The heating and hot water system complies with the appropriate Building Regulations Yes
 The system and associated products have been installed and commissioned in accordance with the manufacturer's instructions Yes
 The efficient operation of system and its controls have been demonstrated to and understood by the customer Yes
 The manufacturer's literature, including Benchmark Checklist and Service Record, has been explained and left with the customer Yes

Commissioning Engineer's Signature _____
 Customer's Signature _____
 (To confirm demonstration of equipment and receipt of appliance instructions)

* All installations in England and Wales must be notified to Local Authority Building Control (LABC) either directly or through a Competent Persons Scheme. A Building Regulations Compliance Certificate will then be issued to the customer.



Service Record

It is recommended that your heating system is serviced regularly and that the appropriate Service Interval Record is completed.

Service Provider

Before completing the appropriate Service Interval Record below, please ensure you have carried out the service as described in the manufacturer's instructions.

Always use the manufacturer's specified spare part when replacing controls.

Service 1

Date: _____

Engineer Name: _____

Company Name: _____

Telephone No. _____

Operative ID No. _____

Comments: _____

Signature: _____

Service 2

Date: _____

Engineer Name: _____

Company Name: _____

Telephone No. _____

Operative ID No. _____

Comments: _____

Signature: _____

Service 3

Date: _____

Engineer Name: _____

Company Name: _____

Telephone No. _____

Operative ID No. _____

Comments: _____

Signature: _____

Service 4

Date: _____

Engineer Name: _____

Company Name: _____

Telephone No. _____

Operative ID No. _____

Comments: _____

Signature: _____

Service 5

Date: _____

Engineer Name: _____

Company Name: _____

Telephone No. _____

Operative ID No. _____

Comments: _____

Signature: _____

Service 6

Date: _____

Engineer Name: _____

Company Name: _____

Telephone No. _____

Operative ID No. _____

Comments: _____

Signature: _____

Service 7

Date: _____

Engineer Name: _____

Company Name: _____

Telephone No. _____

Operative ID No. _____

Comments: _____

Signature: _____

Service 8

Date: _____

Engineer Name: _____

Company Name: _____

Telephone No. _____

Operative ID No. _____

Comments: _____

Signature: _____

Service 9

Date: _____

Engineer Name: _____

Company Name: _____

Telephone No. _____

Operative ID No. _____

Comments: _____

Signature: _____

Service 10

Date: _____

Engineer Name: _____

Company Name: _____

Telephone No. _____

Operative ID No. _____

Comments: _____

Signature: _____

Johnson & Starley are the leading UK & European manufacturers of a complete range of **Domestic Warm Air Heaters**.

All the heaters suit both **Replacement** and **Upgrade** needs and are compliant with the new (2006) amendments to Part L of the Building Regulations.

HOME COMFORT SOLUTIONS

Company Details

Website Address	www.johnsonandstarley.co.uk
Email	sales@johnsonandstarley.co.uk marketing@johnsonandstarley.co.uk
Telephone Number	01604 762881 (Main switchboard)
Fax Number	01604 767408

Spares

Telephone	01604 707012
Fax	01604 762884

Sales

Telephone	01604 707012
Fax	01604 764879

Service

Telephone	01604 707011
Fax	01604 707017

Warm Air Upgrade Enquiry Service

Telephone	01604 707026
Fax	01604 707017

COMMERCIAL & INDUSTRIAL H&V SOLUTIONS



Company Details

Johnson & Starley	Dravo Division Industrial H&V
Website Address	www.dravo.co.uk
Email	dravo@johnsonandstarley.co.uk
Telephone Number	01604 707022
Fax Number	01604 706467

