

THE IDEAL USERS GUIDE

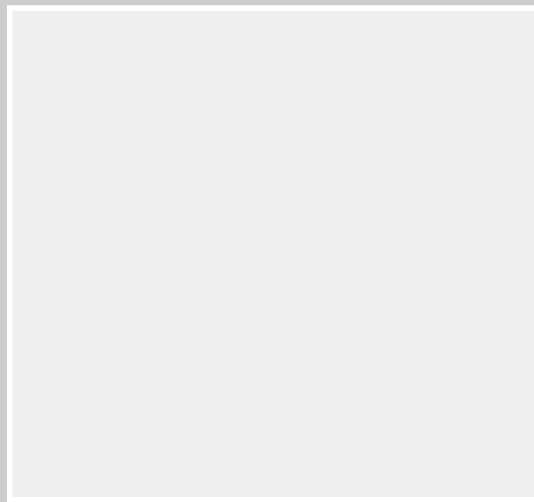

mexico

the floor standing boiler

Floor standing,
gas fired boiler

Mexico Super
RS 3/40 - 3/125
CF 3/40 - 3/140

i BOILERS *Ideal*

Mexico:

The Floor Standing Gas Boiler

The Ideal Mexico is a range of cast iron floor standing gas central heating boilers. Both balanced or conventional flue versions are available. A complete range of both natural gas and propane models. The range offers Super models and, for when space is tight, there are Slimline models available.

Mexico: Britain's biggest selling floor standing boiler

The ideal replacement boiler...

Easy to install, easy to operate and easy to service. The Ideal Mexico really is the ultimate replacement floor standing range - you can depend on it.

Proven reliability...

Proven cast iron heat exchanger engineered and refined to be the most dependable floor standing boiler ensuring totally calm operation and quiet running, whatever the system demands.

Complete range...

27 models, including 4 Slimline models at only 250mm wide and 8 propane Super models. Option kit availability includes an easy to use programmer kit available on all models, an overheat thermostat kit for all models and a pump kit that can be housed within the casing, available for all models except the Super CF 3/140 & CF 3/140P.

Full system suitability...

All models are suitable for connection to pumped open vent central heating systems, pumped central heating combined with pumped or gravity indirect domestic hot water supply systems. They can also be used on sealed water systems when used in conjunction with the optional Overheat Thermostat Kit.

Free Guarantee: 1st Year Ideal Care

The home owner is entitled to 12 months free Ideal Care, which includes both parts and labour, to restore the boiler to full function. Please encourage the home owner to complete and return the registration form in their Householder's pack within 30 days of installation.

Optional Extra Year Cover with Ideal Care

You may wish to offer your own annual service plan or you may wish to advise the home owner to complete their application form for the appropriate level of extended Ideal Care - Silver, Gold or Platinum. Full details are available in the Ideal Care brochure.

Mexico Super (Natural Gas Models Only)

Mexico Super	CF 3/40	G.C. No. 41 348 10	Mexico Super	RS 3/40	G.C. No. 41 349 27
Mexico Super	CF 3/50	G.C. No. 41 348 12	Mexico Super	RS 3/50	G.C. No. 41 349 28
Mexico Super	CF 3/60	G.C. No. 41 348 13	Mexico Super	RS 3/60	G.C. No. 41 349 29
Mexico Super	CF 3/70	G.C. No. 41 348 14	Mexico Super	RS 3/70	G.C. No. 41 349 30
Mexico Super	CF 3/80	G.C. No. 41 348 16	Mexico Super	RS 3/80	G.C. No. 41 349 31
Mexico Super	CF 3/100	G.C. No. 41 348 18	Mexico Super	RS 3/100	G.C. No. 41 349 32
Mexico Super	CF 3/125	G.C. No. 41 348 20	Mexico Super	RS 3/125	G.C. No. 41 349 33
Mexico Super	CF 3/140	G.C. No. 41 348 21			

Certified - P.I. No. RS 87 AT 14

Certified - P.I. No. CF 87 AT 15

Destination Countries: GB, IE

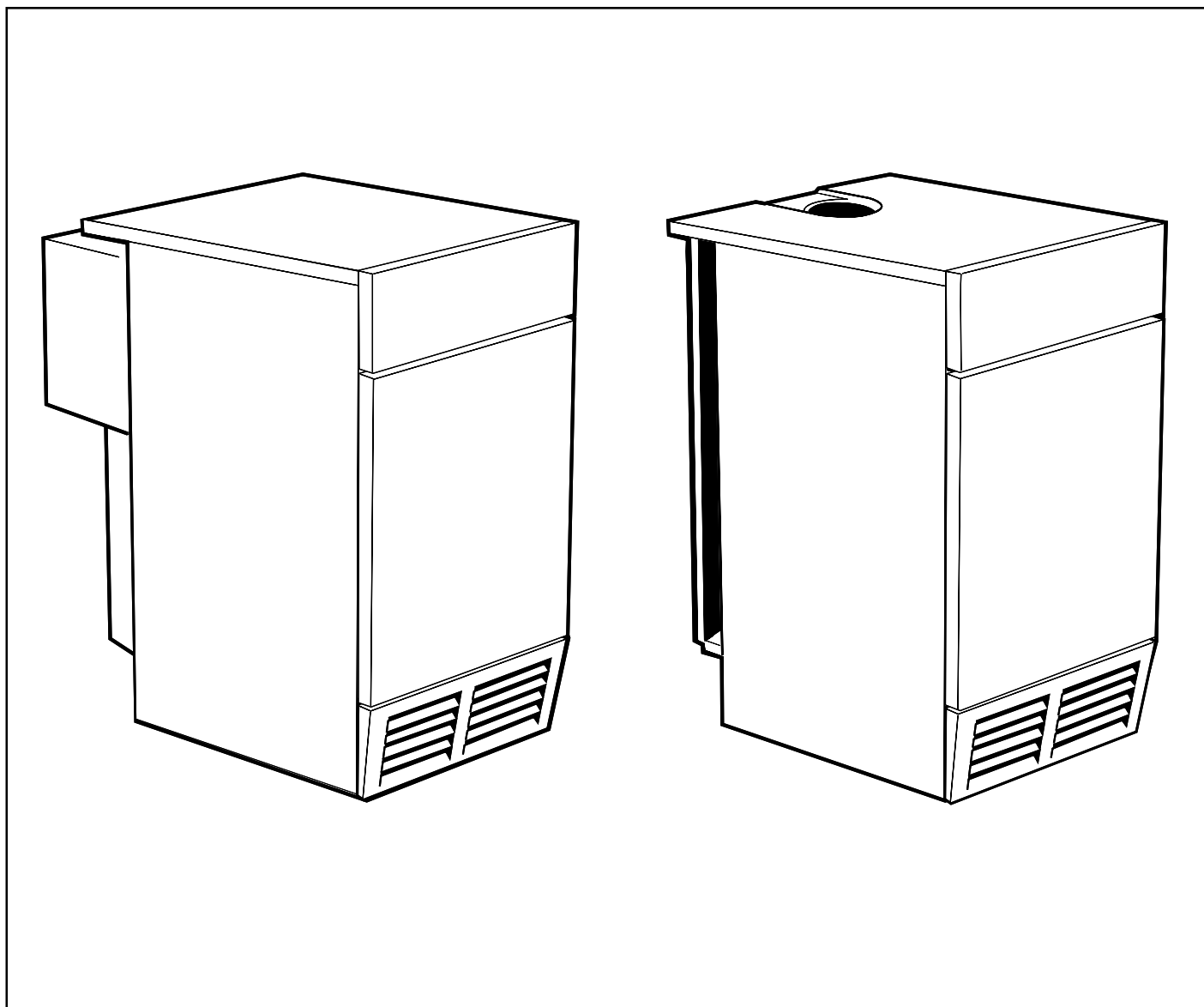

CAUTION. To avoid the possibility of injury during the installation, servicing or cleaning of this appliance care should be taken when handling edges of sheet steel components

Safety

It is essential that the instructions in this booklet are strictly followed, for safe and economical operation of the boiler.

Gas Safety (Installation & Use) Regulations 1994, Amendments 1996 or rules in force.

In your own interest, and that of safety, it is the law that this boiler must be installed by a registered installer, in accordance with all national and local regulations.

Electricity Supply

This appliance must be efficiently earthed.

Supply: 230 V ~ 50 Hz.

The fusing should be 3A.

Connection must be made in a way that allows complete isolation of the electrical supply such as a double pole switch having a 3mm (1/8") contact separation in both poles, or a plug and socket, serving only the boiler and system controls. The means of isolation must be accessible to the user after installation.

Important Points

- If the boiler is installed in a compartment then the compartment **MUST NOT** be used for storage purposes.
- The ventilation provided for the boiler during installation **MUST NOT** be blocked, and a check should be made periodically that the ventilation areas are free from any obstruction.

- If it is known or suspected that a fault exists on the boiler then it **MUST NOT** be used until the fault has been corrected by a CORGI registered installer.
- Inflammable materials must not be placed in close proximity to the appliance. Materials giving off flammable vapours must not be stored in the same room as the appliance.
- Under **NO** circumstances should any of the sealed components on this appliance be used incorrectly or tampered with.

TTB Downdraught Thermostat

(CF boilers only)

This appliance is fitted with a TTB downdraught thermostat for added safety and protection. If this thermostat should operate and switch off the appliance it is because the flue is subject to downdraught, probably as a result of adverse wind conditions.

The TTB is an automatic reset thermostat which will reset once wind conditions have returned to normal, subject to a built-in reset delay in excess of 10 minutes.

The TTB is an IMPORTANT SAFETY DEVICE and MUST NOT be put out of action or interfered with in any way.

The TTB is not a substitute for an independently mounted carbon monoxide detector.

In cases of repeated or continuous shutdown a CORGI registered person should be called to investigate and rectify the condition causing this and carry out an operational test after each intervention on the device. Only the manufacturer's original parts should be used for replacement.

Minimum Clearances

A clearance of 533mm (21") **MUST** be available at the front of the boiler for servicing.

The minimum clearances given in Table 1 **MUST** be complied with, in order to maintain the safe running of the boiler.

1 BOILER CLEARANCES

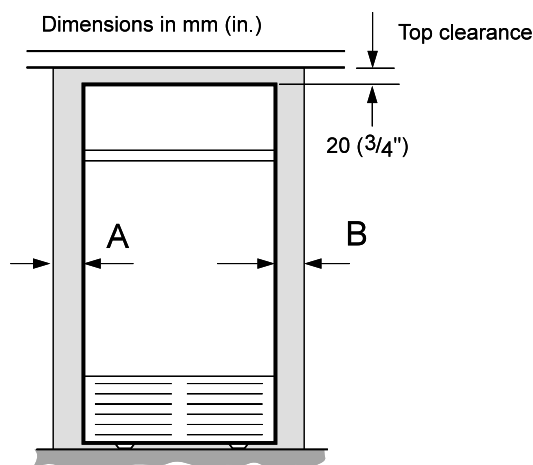

Table 1

Boiler	Minimum A or B		Minimum A + B	
	mm	(ins.)	mm	(ins.)
CF 3/40	10	(3/8)	50	(2)
CF 3/50, 3/60, 3/70	10	(3/8)	110	(4 1/2)
CF 3/80	55	(2 1/4)	110	(4 1/2)
CF 3/100	35	(1 3/8)	135	(5 1/4)
CF 3/125	50	(2)	210	(8 1/4)
CF 3/140	150	(6)	300	(12)
RS 3/125	55	(2 1/4)	110	(4 1/2)
all other RS models	10	(3/8)	20	(3/4)

THE LOG BOOK SHOULD BE COMPLETED AFTER EACH SERVICE AND KEPT WITH THESE INSTRUCTIONS



2 BOILER CONTROLS

RS boiler shown

LEGEND

- A Boiler thermostat knob
- B Gas control knob
- C Ignition button
- D Sightglass
- E Overheat thermostat (optional) reset button

Note.

Grille assembly not shown, for clarity

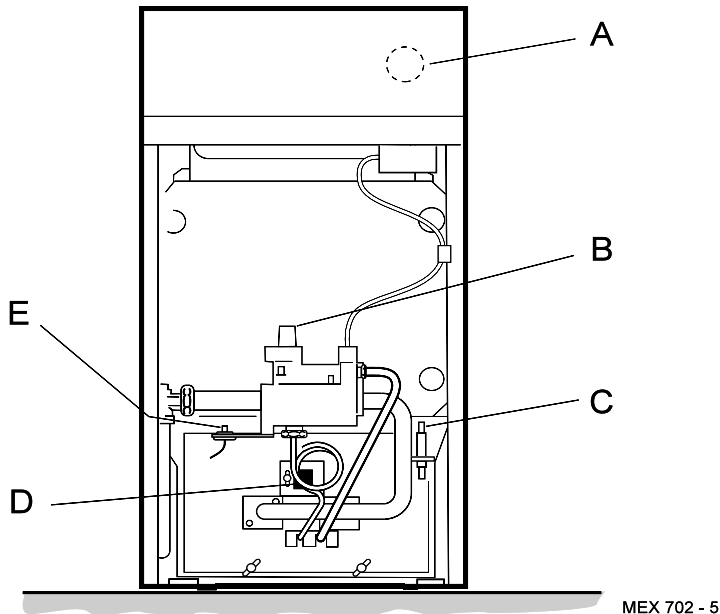

To light the boiler. Refer to Frame 2

If a programmer is fitted refer to separate instructions for the programmer before continuing.

1. Check that the electricity supply to the boiler is OFF.
2. Remove the lower front panel by pulling it forward and lifting out.
3. Open the control panel drop-down door and ensure that the thermostat knob (A) is in the OFF position.
4. Turn the gas control knob (B) to the RIGHT until resistance is felt and then release it.

Wait for 3 minutes.

5. Push in and retain fully depressed the gas control knob (B). Press and release the ignition button (C) repeatedly until the pilot flame can be seen through the sight glass (D). When the pilot has lit, continue to press in the gas control knob (B) for a further 15 seconds.
6. Should the pilot go out at this or any other stage, turn the gas control knob (B) CLOCKWISE and release it. Wait for 3 minutes then repeat instruction 5 - but wait longer than 15 seconds before releasing the gas control knob.
7. Switch ON the electricity supply to the boiler and check that all external controls, e.g. room thermostat etc., are ON.
8. Turn the boiler thermostat knob (A) to position 6 and the boiler will light. Set the boiler thermostat to the desired setting.
9. Refit the lower front panel by locating the bottom edge behind the top of the grille assembly and pushing the panel backwards to engage in the upper clips.

Winter conditions (i.e. central heating and domestic hot water). The thermostat should be positioned at setting 5 or 6.

Summer conditions (i.e. domestic hot water only). The thermostat should be positioned at setting 2.

These settings are offered for general guidance only and other settings may be found preferable, dependent upon the type of system installed or as recommended by the installer.

To shut down the boiler

1. For short periods

Turn the boiler thermostat knob (A) to OFF. When heating is again required, restore the knob to its original setting.

2. For longer periods

- a. Turn the boiler thermostat knob (A) to OFF.
- b. Turn the gas control knob (B) CLOCKWISE until resistance is felt then release it to extinguish the pilot burner.
- c. Switch the electricity supply to OFF.

Frost protection

If no frost protection is provided and frost is likely during a short absence from home, leave the heating controls (if fitted) at a reduced temperature setting.

For longer periods, the entire system should be drained - including the domestic water supply.

If the system includes a frost thermostat then, during cold weather, the boiler should be turned OFF at the time switch (if fitted) ONLY. The mains supply should be left switched ON, with the boiler thermostat left in the normal running position.

Control of water temperature

1. Set the boiler thermostat knob (A) to give the required temperature for central heating.
2. The boiler thermostat automatically switches the main burner OFF and ON to maintain the selected temperature.
3. The pilot burner remains alight continuously to give re-ignition of the main burner.

To relight the boiler

Repeat the procedure 1 - 9 detailed in 'To light the boiler'.

Boiler Overheat Thermostat

(Fitted for sealed systems only)

The boiler is fitted with a safety 'cutout' thermostat. This thermostat will extinguish the pilot and shut down the boiler in the event of overheating. Should this occur, allow the boiler to cool, press the reset button (E) on the overheat thermostat then relight as detailed in steps 1-9 under 'To light the boiler'.

If the 'cutout' condition persists turn off the boiler and consult a CORGI registered installer.

Loss of system water pressure **(Boilers fitted with the Overheat Thermostat Kit only)**

If the red arrow on the system pressure gauge is set above zero and the system pressure is seen to fall below this value over a period of time then a water leak is indicated. In this event a CORGI registered installer should be consulted.

DO NOT FIRE THE BOILER IF THE PRESSURE HAS REDUCED TO ZERO FROM THE ORIGINAL SETTING

Escape of gas

Should a gas leak or fault be suspected, contact your gas supplier *without delay*.

Do NOT search for gas leaks with a naked flame.

Cleaning

For normal cleaning simply dust with a dry cloth.

To remove stubborn marks and stains, wipe with a damp cloth and finish off with a dry cloth.

Do NOT use abrasive cleaning materials.

Maintenance

The appliance should be serviced at least once a year by a CORGI registered installer.

Note. *The appliance model is given on the data plate, located on the front of the boiler base plate, behind the grille assembly.*



The code of practice for the installation, commissioning & servicing of central heating systems

Caradon Plumbing Limited is a member of the Benchmark initiative and fully supports the aims of the programme. Benchmark has been introduced to improve the standards of installation and commissioning of central heating systems in the UK and to encourage the regular servicing of all central heating systems to ensure safety and efficiency.



THIS SYMBOL IS YOUR ASSURANCE OF QUALITY

These appliances are designed for use with Natural Gas only. They have been tested and conform with the provisions of BS. 6332 and BS. 5258.



CERTIFIED PRODUCT
Manufactured under a BS EN ISO 9001:1994
Quality System accepted by BSI

CARADON PLUMBING Ltd. pursues a policy of continuing improvement in the design and performance of its products. The right is therefore reserved to vary specification without notice.

September 1999

151914 A02

CARADON PLUMBING Ltd, P.O. Box 103, National Ave, Kingston upon Hull, HU5 4JN. Telephone: 01482 492 251 Fax: 01482 448 858. Registration No. London 322 137. Registered Office: National Avenue, Kingston upon Hull, HU5 4JN. *A subsidiary of Caradon p.l.c*

***i* Ideal** BOILERS

Ideal Consumer Helpline: 01482 498660

***Your feedback
and your chance to win a free boiler***

At Ideal we've been leaders in the design and engineering of robust and reliable boilers for over 90 years. We want to continue as leaders by listening to your suggestions for how to improve our boilers and our service. We'll be giving away a free boiler for the five best ideas every year (to be selected by our Technical Director). Please complete this form, using extra sheets if required, and post it or fax it to us on 01482 498699.

Boiler details

Model / Size (e.g. Classic RS 230, Mexico CF 3/60 etc. Details on control panel door)

Date of Installation

Installer details

Name

Address

Post Code

Telephone (Please include STD code)

How I would improve this boiler:

My general comments for Ideal:

Caradon 
Plumbing Solutions

Ideal Consumer Helpline: 01482 498660

Further information

If you would like information about Ideal Boilers please complete this sheet and fax it to us on 01482 498699 or post it to Caradon Plumbing Limited, PO Box 103, National Avenue, Kingston upon Hull, HU5 4JN.

Installer details

Name

Address

Post Code

Telephone (Please include STD code)

General information required

- Please send me details of Ideal Training Courses.
- Please arrange for a technical representative to contact me.
- Please arrange for me to join an Ideal factory tour.

Range guides required

- The Ideal Guide: a specifier's and installer's introduction to the Ideal domestic boiler range.
- The Ideal Householders Guide: to assist the installer when presenting to his/her customers.

Technical manuals required

- The Ideal C class combi boiler
- The Ideal Classic wall hung boiler
- The Ideal Classic System wall hung boiler
- The Ideal Classic LX Deluxe wall hung boiler
- The Ideal Mexico floor standing boiler
- The Ideal Minimiser heat-saving boiler
- The Ideal Response combi boiler
- The Ideal Response SE super efficiency combi boiler
- The Ideal Systemiser SE super efficiency system boiler
- The Ideal Concord high output boiler
- The Ideal Buccaneer oil fired boiler

Caradon 
Plumbing Solutions

CARADON PLUMBING Ltd, PO Box 103, National Avenue, Kingston upon Hull, HU5 4JN. Telephone: 01482 492251 Fax: 01482 448858.

Ideal Consumer Helpline: 01482 498660

