

# INSTALLATION AND SERVICING

## LOGIC System 15, 18, 24, 30

For users guide see reverse of book



**For details of document amendments, refer to page 3**

When replacing any part on this appliance, use only spare parts that you can be assured conform to the safety and performance specification that we require. Do not use reconditioned or copy parts that have not been clearly authorised by Ideal.

**For the very latest copy of literature for specification and maintenance practices visit our website [www.idealheating.com](http://www.idealheating.com) where you can download the relevant information in PDF format.**





## NOTES FOR THE INSTALLER

**FOR ANY TECHNICAL QUERIES PLEASE RING THE  
IDEAL INSTALLER/TECHNICAL HELPLINE : 01482 445570**

**NOTE. BOILER RESET PROCEDURE -**

To reset boiler, turn mode knob to reset position and immediately turn knob back to required setting.  
The boiler will repeat the ignition sequence.

## DOCUMENT AMENDMENTS

Relevant Installation changes implemented in this book from Mod Level .....A01 (June 10) to A02 (Nov 10)

**Page 4, Table 2**

New Sedbuk 2009 figures

**Page 8, Gas Supply**

New graph added - Gas Cock Pressure Drop

**Page 8, Flue Installation**

New "IMPORTANT" note added.

**Page 12, Frame 4 Water Treatment**

Addition of Scalemaster Gold 100

**Page 14, Frame 16 Unpacking**

Pack A Contents - New item G added.

**Page 23, Frame 23 Connecting the Flue to the Boiler**

Key no. 4 updated ref flue seal.

**Page 30, Frame 33 Wiring Diagram**

Updated wiring diagram

**Short List of Parts diagrams**

Page deleted refer to Boiler Assembly Frame

**Installer Notification Guidelines**

Page deleted

**Page 56 - 57 Commissioning Checklist**

Forms updated

**Boiler Guarantee**

Page deleted. Now found in Guarantee /Registration Pack

# GENERAL

**Table 1 - General Data**

Ideal Logic System			15	18	24	30
Gas supply			2H - G20 - 20mbar			
Gas Supply Connection			15mm copper compression			
Injector Size	(mm)		4.15	4.15	4.15	4.65
Flow Connection	Central Heating		22mm copper compression			
Return Connection	Central Heating		22mm copper compression			
Flue Terminal Diameter	mm (in)		100 (4)			
Average Flue Temp-Mass Flow Rate			56°C - 6g/s	58°C - 8 g/s	63°C - 10g/s	69°C - 13g/s
Maximum Working Pressure (Sealed Systems)	bar (lb/in <sup>2</sup> )		2.5 (36.3)			
Electrical Supply			230 V ~ 50 Hz.			
Power Consumption	W		126	131	146	152
Fuse Rating			External : 3A Internal : T4H HRC L250 V			
Water content	litre (gal)		1.2 (0.26)			
Packaged Weight	kg (lb)		34.4 (76)	34.4 (76)	34.4 (76)	34.4 (76)
Maximum Installation Weight	kg (lb)		28 (61.7)	28 (61.7)	28 (61.7)	28 (61.7)
Boiler Casing Size	Height	mm (in)	700 (27.5)			
	Width	mm (in)	395 (15.5)			
	Depth	mm (in)	278 (11)			

**Table 2 - Performance Data - Central Heating**

			15		18		24		30	
			MIN	MAX	MIN	MAX	MIN	MAX	MIN	MAX
Boiler Input :										
Boiler Input 'Q'	Nett CV	kW	4.9	15.1	4.9	18.1	4.9	24.3	6.1	30.4
		(Btu/h)	(16,600)	(51,520)	(16,600)	(61,800)	(16,600)	(82,900)	(20,700)	(103,600)
	Gross CV	kW	5.4	16.6	5.4	20.1	5.4	27.0	6.7	33.7
		(Btu/h)	(18,400)	(56,800)	(18,400)	(68,600)	(18,400)	(92,000)	(23,000)	(115,000)
Gas Consumption	l/s		0.139	0.427	0.139	0.52	0.139	0.698	0.173	0.871
	(ft <sup>3</sup> /h)		(17.8)	(54.7)	(17.8)	(66.1)	(17.8)	(89)	(22)	(111)
Boiler Output :										
Non Condensing kW			4.8	15.0	4.8	18.0	4.8	24.2	6.1	30.3
70°C Mean Water temp.	(Btu/h)		(16,500)	(51,300)	(16,500)	(61,600)	(16,500)	(82,600)	(20,700)	(103,300)
Condensing kW			5.1	15.9	5.1	19.1	5.1	25.6	6.4	31.0
40°C Mean Water temp.	(Btu/h)		(17,500)	(54,250)	(17,500)	(65,100)	(17,500)	(87,400)	(21,800)	(105,800)
Seasonal efficiency* SEDBUK 2005			91.1%		91%		91%		91.1%	
Seasonal efficiency* SEDBUK 2009			89.3		89.2%		89.5%		89.6%	
NOx Classification			CLASS 5							

\* The value is used in the UK Government's Standard Assessment Procedure (SAP) for energy rating of dwellings. The test data from which it has been calculated have been certified by a notified body.

**Note.** Gas consumption is calculated using a calorific value of 38.7 MJ/m<sup>3</sup> (1038 Btu/ft<sup>3</sup>) gross or 34.9 MJ/m<sup>3</sup> (935 Btu/ft<sup>3</sup>) nett

To obtain the gas consumption at a different calorific value:

- For l/s - divide the gross heat input (kW) by the gross C.V. of the gas (MJ/m<sup>3</sup>)
- For ft<sup>3</sup>/h - divide the gross heat input (Btu/h) by the gross C.V. of the gas (Btu/ft<sup>3</sup>)
- For m<sup>3</sup>/h - multiply l/s by 3.6.

### Key to symbols

**GB** = United Kingdom    **IE** = Ireland    (Countries of destination)

**PMS** = Maximum operating pressure of water

**C<sub>13</sub> C<sub>33</sub> C<sub>53</sub>** = A room sealed appliance designed for connection via ducts to a horizontal or vertical terminal, which admits fresh air to the burner and discharges the products of combustion to the outside through orifices which, in this case, are concentric. The fan is up stream of the combustion chamber.

**I<sub>2H</sub>** = An appliance designed for use on 2nd Family gas, Group H only.

# GENERAL

## IDEAL LOGIC SYSTEM

Natural Gas only

Boiler size	G.C. Appliance No. (Benchmark No.)	PI No.
15	41-750-24	86 CL 08
18	41-750-25	86 CL 08
24	41-750-26	86 CL 08
30	41-750-27	86 CL 08

Destination Country: GB, IE

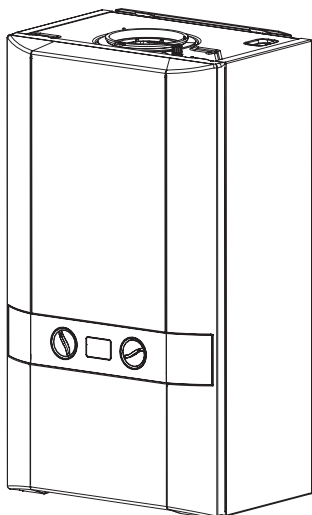

## CONTENTS

Air Supply .....	9
Benchmark Commissioning Checklist .....	56
Boiler Clearances .....	10
Boiler Exploded Diagram .....	13
Condensate Drain .....	21,22
Commissioning & Testing .....	31
Electrical Connections .....	27
Electrical Supply .....	9
Extension Ducts - Fitting .....	19,20
Fault Finding .....	49-53
Flue Fitting .....	15
Flue Installation .....	8
Gas Safety Regulations .....	7
Gas Supply .....	8
Initial Lighting .....	32
Installation .....	14-33
Pump .....	46
Safe Handling .....	6
Servicing .....	34-48
Short List of Parts .....	54
Thermostatic Radiator Valves .....	9
Water and Systems .....	9,11-12
Water Connections .....	10,27
Water Treatment .....	12
Wiring Diagram .....	30

For GB, to comply with Building Regulations Part L1 (Part 6 in Scotland) the boiler should be fitted in accordance with the manufacturer's instructions. Self-certification that the boiler has been installed to comply with Building Regulations can be demonstrated by completing and signing the Benchmark Commissioning Checklist.

Before installing this boiler, read the Code of Practice sheet at the rear of this book.

### BENCHMARK COMMISSIONING CHECKLIST DETAILS

Boiler	Page	Page	
Make and model.....	5	Burner operating pressure .....	n/a
Appliance serial no. on data badge .....	Front Cover	Central heating flow temp. ....	measure and record
SEDBUK No. %.....	4	Central heating return temp. ....	measure and record
<b>Controls</b>		<b>For combination boilers only</b>	
Time and temperature control to heating .....	30	Scale reducer .....	12
Time and temperature control to hot water .....	N/A	<i>Hot water mode</i>	
Heating zone valves.....	29	Heat input.....	to be calculated
TRV's.....	9	Max. operating burner pressure .....	n/a
Auto bypass .....	9	Max. operating water pressure.....	measure & record
Boiler interlock.....	9	Cold water inlet temp .....	measure & record
<b>For .....</b>	<b>all boilers</b>	Hot water outlet temp.....	measure & record
Flushing to BS.7593.....	12	Water flow rate at max. setting.....	measure & record
Inhibitor .....	12	<b>For condensing boilers only</b>	
<i>Central heating mode</i>		Condensate drain.....	21,22
Heat input.....	to be calculated	<b>For all boilers:</b> <i>complete, sign &amp; hand over to customer</i>	
		For assistance see Technical Helpline on the back page	

**NOTE TO THE INSTALLER: COMPLETE THE BENCHMARK COMMISSIONING CHECKLIST AND LEAVE THESE INSTRUCTIONS WITH APPLIANCE**



## INTRODUCTION

The **Logic System** range of boilers are wall mounted, full sequence, automatic spark ignition, low water content, fanned flue, high efficiency, condensing, system gas boilers.

**Note.** *Due to the high efficiency of the boiler a plume of water vapour will form at the terminal during operation.*

Central heating (CH) output is fully modulating with a range of:

15	4.8 to 15kW (16,500 to 51,300 Btu/h)
18	4.8 to 18kW (16,500 to 61,600 Btu/h)
24	4.8 to 24.2kW (16,500 to 82,600 Btu/h)
30	6.1 to 30.3kW (20,700 to 103,300 Btu/h)

The boiler is supplied fully assembled with circulating pump, pressure gauge, safety valve and CH expansion vessel.

A variable CH temperature control is fitted on the user control.

The boiler includes as standard:

- Boiler frost protection
- Daily pump exercise.

The boiler casing is of white painted mild steel.

The boiler temperature control is visibly located in the control panel on the front of the boiler.

The heat exchanger is manufactured from cast aluminium.

The boiler is suitable for connection to fully pumped, sealed heating systems ONLY. Adequate arrangements for completely draining the system by provision of drain cocks MUST be provided in the installation pipework.

Pipework from the boiler is routed downwards.

## OPERATION

When there is a demand for CH, the heating system is supplied at the selected temperature of between 30°C and 80°C.

The boiler features a comprehensive diagnostic system which gives detailed information on the boiler status when operating, and performance of key components to aid commissioning and fault finding.

## SAFE HANDLING

This boiler may require 2 or more operatives to move it to its installation site, remove it from its packaging base and during movement into its installation location. Manoeuvring the boiler may include the use of a sack truck and involve lifting, pushing and pulling.

Caution should be exercised during these operations.

Operatives should be knowledgeable in handling techniques when performing these tasks and the following precautions should be considered:

- Grip the boiler at the base.
- Be physically capable.
- Use personal protective equipment as appropriate, e.g. gloves, safety footwear.

During all manoeuvres and handling actions, every attempt should be made to ensure the following unless unavoidable and/or the weight is light.

- Keep back straight.
- Avoid twisting at the waist.
- Avoid upper body/top heavy bending.
- Always grip with the palm of the hand.
- Use designated hand holds.
- Keep load as close to the body as possible.
- Always use assistance if required.

## OPTIONAL EXTRA KITS

- **Horizontal Flue Terminal** (600mm long)
- **Horizontal Flue Terminal** (1000mm long)
- **Horizontal Flue Telescopic**
- **Flue Extension Ducts** (1000mm long)
  - 15-up to 9m
  - 18-up to 9m
  - 24-up to 9m
  - 30-up to 8m
- **Flue Finishing Kit**
- **90° Elbow Kit** (maximum per installation).
  - 15-up to 6 elbows
  - 18-up to 6 elbows
  - 24-up to 6 elbows
  - 30-up to 6 elbows
- **45° Elbow Kit** (maximum per installation).
  - 15-up to 6 elbows
  - 18-up to 6 elbows
  - 24-up to 6 elbows
  - 30-up to 6 elbows
- **Concentric Flue Screw Retaining Kit**
- **Roof Flue Kit** (to a maximum of 7.5m)
- **Powered Vertical Flue Kit** (5m primary and 17m secondary is a typical maximum length. For alternative details refer to Powered Vertical Instructions)
- **Weather Collar (Universal)**
- **Weather Collar (Flat Roof)**
- **Pre-Piping Frame Kit**
- **Stand-Off Kit**
- **Stand-Off Kit (inc. pipes)**
- **High Level Flue Outlet Kit**
- **Flue Deflector Kit**
- **Condensate Pump Kit**
- **Weather Compensation Kit**
- **Adjustable Flue Support Bracket**
- **Balcony Flue Kit**
- **Security Bracket Kit**
- **PRV Wall Outlet Kit**

## SAFETY

### Current Gas Safety (installation and use) regulations or rules in force:

The appliance is suitable only for installation in GB and IE and should be installed in accordance with the rules in force.

In GB, the installation must be carried out by a Gas Safe Registered Engineer. It must be carried out in accordance with the relevant requirements of the:

- Gas Safety (Installation and Use) Regulations
- The appropriate Building Regulations either The Building Regulations, The Building Regulations (Scotland), Building Regulations (Northern Ireland).
- The Water Fittings Regulations or Water byelaws in Scotland.
- The Current I.E.E. Wiring Regulations.

Where no specific instructions are given, reference should be made to the relevant British Standard Code of Practice.

In IE, the installation must be carried out by a Registered Gas Installer (RGI) and installed in accordance with the current edition of I.S.813 "Domestic Gas Installations", the current Building Regulations and reference should be made to the current ETCI rules for electrical installation.

Detailed recommendations are contained in the following British Standard Codes of Practice:

- BS. 5440:1** Flues (for gas appliances of rated input not exceeding 70 kW).
- BS. 5440:2** Ventilation (for gas appliances of rated input not exceeding 70 kW).
- BSEN. 12828:2003** Heating Systems in buildings: Design for water based heating systems.
- BSEN 12831:2003** Heating Systems in buildings: Method for calculation of the design heat load.
- BSEN 14336:2004** Heating Systems in buildings: Installation and commissioning of water based heating systems.
- BS. 5546** Installation of gas hot water supplies for domestic purposes (2nd Family Gases)
- BS. 6798** Installation of gas fired hot water boilers of rated input not exceeding 70 kW.
- BS. 6891** Low pressure installation pipes.

### Health & Safety Document No. 635.

### The Electricity at Work Regulations, 1989.

The manufacturer's notes must NOT be taken, in any way, as overriding statutory obligations.

**IMPORTANT.** These appliances are CE certificated for safety and performance. It is, therefore, important that no external control devices, e.g. flue dampers, economisers etc., are directly connected to these appliances unless covered by these Installation and Servicing Instructions or as otherwise recommended by **Ideal Stelrad Group** in writing. If in doubt please enquire.

Any direct connection of a control device not approved by **Ideal Stelrad Group** could invalidate the certification and the normal appliance warranty. It could also infringe the Gas Safety Regulations and the above regulations.

## SAFE HANDLING OF SUBSTANCES

No asbestos, mercury or CFCs are included in any part of the boiler or its manufacture.

## LOCATION OF BOILER

The boiler must be installed on a flat and vertical internal wall, capable of adequately supporting the weight of the boiler and any ancillary equipment.

The boiler may be fitted on a combustible wall and insulation between the wall and the boiler is not necessary, unless required by the local authority.

For electrical safety reasons there must be no access available from the back of the boiler.

**The boiler must not be fitted outside.**

### Timber Framed Buildings

If the boiler is to be fitted in a timber framed building it should be fitted in accordance with the Institute of Gas Engineering document IGE/UP/7:1998.

### Bathroom Installations

This appliance is rated **IP20**.

The boiler may be installed in any room or internal space, although particular attention is drawn to the requirements of the current IEE (BS.7671) Wiring Regulations and the electrical provisions of the building regulations applicable in Scotland, with respect to the installation of the boiler in a room or internal space containing a bath or shower. For IE reference should be made to the current ETCI rules for electrical installations and I.S. 813:2002.

If the appliance is to be installed in a room containing a bath or shower then, providing water jets are not going to be used for cleaning purposes (as in communal baths/showers), the appliance must be installed beyond Zone 2, as detailed in BS.7671.

### Compartment Installations

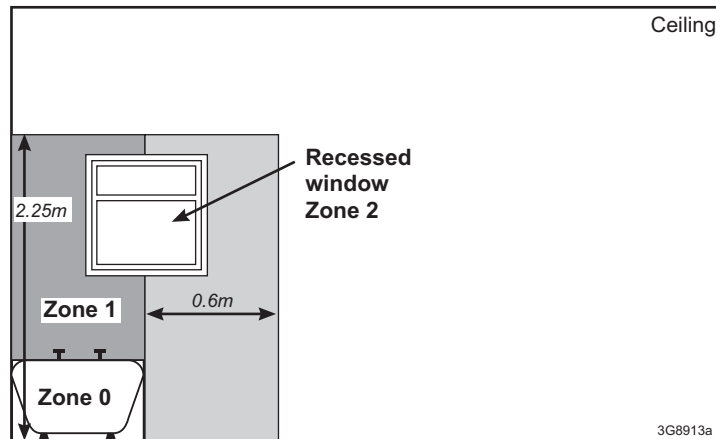

A compartment used to enclose the boiler should be designed and constructed specially for this purpose.

An existing cupboard or compartment may be used, provided that it is modified for the purpose.

In both cases, details of essential features of cupboard / compartment design, including airing cupboard installation, are to conform to the following:

- BS 6798 (No cupboard ventilation is required - see 'Air Supply' for details).
- The position selected for installation MUST allow adequate space for servicing in front of the boiler.
- For the minimum clearances required for safety and subsequent service, see the wall mounting template and Frame 1. In addition, sufficient space may be required to allow lifting access to the wall mounting plate.

## GAS SUPPLY

The local gas supplier should be consulted, at the installation planning stage, in order to establish the availability of an adequate supply of gas. An existing service pipe must NOT be used without prior consultation with the local gas supplier.

The boiler MUST be installed on a gas supply with a governed meter only.

A gas meter can only be connected by the local gas supplier or by a Gas Safe Registered Engineer. In IE by a Registered Gas Installer (RGI).

An existing meter should be checked, preferably by the gas supplier, to ensure that the meter is adequate to deal with the rate of gas supply required.

It is the responsibility of the Gas Installer to size the gas installation pipework in accordance with BS6891:2005. Whilst the principle of the 1:1 gas valve ensures the Logic range is able to deliver it's full output at inlet pressures as low as 14mb, other gas appliances in the property may not be as tolerant. When operating pressures are found to be below the minimum meter outlet of 19mb these should be checked to ensure this is adequate for correct and safe operation.

Allowing for the acceptable pressure loss of 1mb across the installation pipework, it can be assumed that a minimum permitted operating pressure of 18mb will be delivered to the inlet of the appliance. (Reference BS 6400-1 Clause 6.2 Pressure Absorption).

The external gas cock could further reduce the operating pressure when measured at its test point. The pressure drop is relative to the heat input to the boiler (kW), refer to graph below.

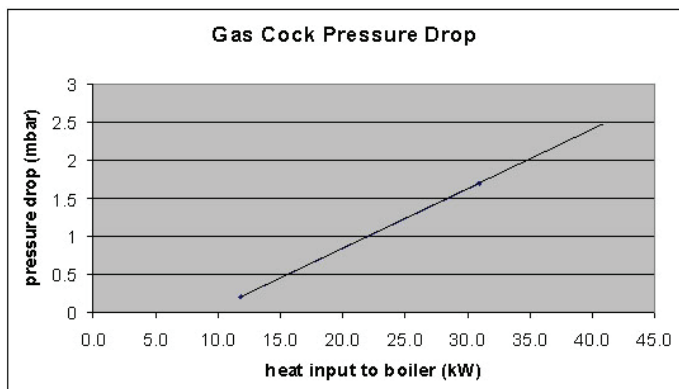

### IMPORTANT.

Installation pipes must be fitted in accordance with BS.6891. In IE refer to IS.813:2002.

The complete installation MUST be tested for gas tightness and purged as described in the above code.

## FLUE INSTALLATION

Plumbing will occur at the terminal so terminal positions where this could cause a nuisance should be avoided.

The flue must be installed in accordance with the recommendations of BS. 5440-1: 2008.

In IE refer to I.S. 813:2002.

The following notes are intended for general guidance:

1. The boiler MUST be installed so that the terminal is exposed to external air.
2. It is important that the position of the terminal allows the free passage of air across it at all times.
3. Minimum acceptable spacing from the terminal to obstructions and ventilation openings are specified in Table 4.

4. Where the lowest part of the terminal is fitted less than 2m (6'6") above a balcony, above ground or above a flat roof to which people have access then the terminal MUST be protected by a purpose designed guard.

Terminal guards are available from boiler suppliers. (Ask for TFC flue guard model no. K6 - round, plastic coated). In case of difficulty contact:

Grasslin (UK) Ltd. Tel. + 44 (0) 01732 359 888  
 Tower House, Vale Rise Fax. + 44 (0) 01732 354 445  
 Tonbridge. Kent TN9 1TB www.tfc-group.co.uk

Ensure that the guard is fitted centrally.

5. The flue assembly shall be so placed or shielded as to prevent ignition or damage to any part of any building.
6. The air inlet/products outlet duct and the terminal of the boiler MUST NOT be closer than 25mm (1") to combustible material. Detailed recommendations on the protection of combustible material are given in BS. 5440-1:2008.

**IMPORTANT.** It is essential to ensure, in practice, that products of combustion discharging from the terminal cannot re-enter the building or buildings through any openings into the building such as ventilators, windows, doors, or other sources of natural air infiltration, such as forced ventilation openings etc.

If products of combustion re-entry is identified or suspected this should be immediately investigated and corrected following the guidance provided in the current Gas Industry Unsafe Situation Procedure.

**Table 4 - Balanced Flue Terminal Position**

Flue Terminal Positions	Min. Spacing*
1. Directly below, above or alongside an opening window, air vent or other ventilation opening.	300mm (12")
2. Below guttering, drain pipes or soil pipes. <i>BS5440-1 2008</i>	25mm (1")* 75mm (3")
3. Below eaves. <i>BS5440-1 2008</i>	25mm (1")* 200mm (8")
4. Below balconies or a car port roof. <i>BS5440-1 2008</i>	25mm (1")* 200mm (8")
5. From vertical drain pipes or soil pipes. <i>BS5440-1 2008</i>	25mm (1")* 150mm (6")
6. From an internal or external corner or to a boundary along side the terminal. <i>BS5440-1 2008</i>	25mm (1")* 300mm (12")
7. Above adjacent ground, roof or balcony level.	300mm (12")
8. From a surface or a boundary facing the terminal.	600mm (24")
9. From a terminal facing a terminal.	1,200mm (48")
10. From an opening in a car port (e.g. door or window) into dwelling.	1,200mm (48")
11. Vertically from a terminal on the same wall.	1,500mm (60")
12. Horizontally from a terminal on the wall.	300mm (12")
<b>Vertical Terminals</b>	
13. Above the roof pitch with roof slope of all angles. Above flat roof.	300mm (12") 300mm (12")
14. From a single wall face. From corner walls.	300mm (12") 300mm (12")
15. Below velux window	2000mm (79")
16. Above or side of velux window	600mm (24")

\* Only one reduction down to 25mm is allowable per installation otherwise BS5440-1 2008 dimensions must be followed.



# GENERAL

## TERMINAL

The terminal assembly can be adapted to accommodate various wall thicknesses. Refer to Frame 8 .

## AIR SUPPLY

It is NOT necessary to have a purpose-provided air vent in the room or internal space in which the boiler is installed. Neither is it necessary to ventilate a cupboard or compartment in which the boiler is installed, due to the low surface temperatures of the boiler casing during operation; therefore the requirements of BS 6798, Clause 12, and BS 5440:2 may be disregarded.

## WATER CIRCULATION SYSTEM

### IMPORTANT.

A minimum length of 1 metre of copper pipe MUST be fitted to both flow and return connections from the boiler before connection to any plastic piping.

The central heating system should be in accordance with BS.6798 and, in addition, for smallbore and microbore systems, BS.5449.

**WATER TREATMENT - see Frame 4**

## BOILER CONTROL INTERLOCKS

Central heating systems controls should be installed to ensure the boiler is switched off when there is no demand for heating, in compliance with Building Regulations.

Heating systems utilising full thermostatic radiator valve control of temperature in individual rooms should also be fitted with a room thermostat controlling the temperature in a space served by radiators not fitted with such a valve.

When thermostatic radiator valves are used, the space heating temperature control over a living / dining area or hallway having a heating requirement of at least 10% of the minimum boiler heat output should be achieved using a room thermostat, whilst other rooms are individually controlled by thermostatic radiator valves. However, if the system employs thermostatic radiator valves on all radiators, or two port valves, then a bypass circuit must be fitted with an automatic bypass valve to ensure a flow of water should all valves be in the closed position.

## ELECTRICAL SUPPLY

### WARNING.

This appliance must be earthed.

Wiring external to the appliance MUST be in accordance with the current I.E.E. (BS.7671) Wiring Regulations and any local regulations which apply. For IE reference should be made to the current ETCI rules for electrical installations.

The mains supply to the boiler and system wiring centre shall be through one common fused double pole isolator. For new heating systems, and where practicable replacement boiler installations, the isolator shall be situated adjacent to the appliance.

## CONDENSATE DRAIN

### Refer to Frames 21, 22 & 43

A condensate drain is provided on the boiler. This drain must be connected to a drainage point on site. All pipework and fittings in the condensate drainage system MUST be made of plastic - *no other materials may be used.*

### IMPORTANT.

Any external runs must be in accordance with BS 6798.

The drain outlet on the boiler is sized for standard 21.5mm (3/4") overflow pipe. It is a universal fitting to allow use of different brands of pipework.

# GENERAL

## 1 BOILER DIMENSIONS, SERVICES & CLEARANCES

*all dimensions in mm*

The boiler connections are made on the boiler connection tails. Refer to Frame 28.

The following minimum clearances must be maintained for operation and servicing.

Additional space will be required for installation, depending upon site conditions.

### Side and Rear Flue

a. Provided that the flue hole is cut accurately, e.g. with a core drill, the flue can be installed from inside the building where

wall thicknesses do not exceed 600mm (24"). Where the space into which the boiler is going to be installed is less than the length of flue required the flue must be fitted from the outside.

### Installation from inside ONLY

b. If a core boring tool is to be used inside the building the space in which the boiler is to be installed must be at least wide enough to accommodate the tool.

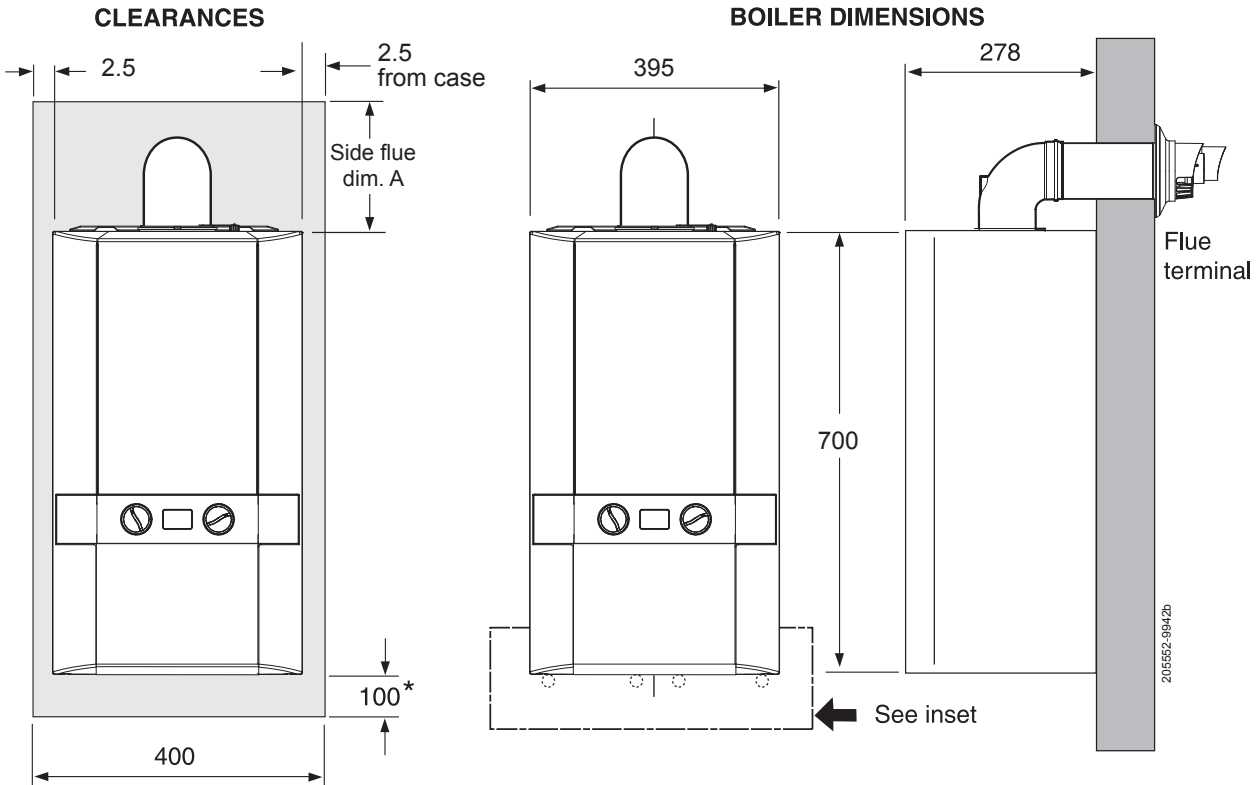

### Inset: Water Connections and Gas Connection

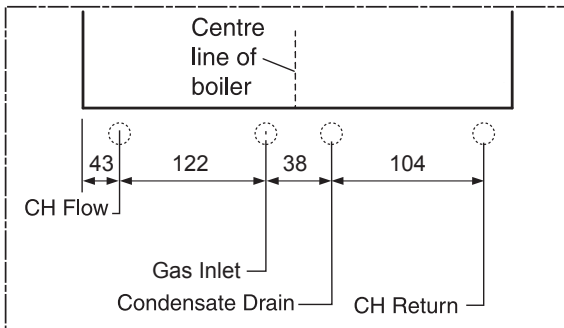

### Front clearance

The minimum front clearance when built in to a cupboard is 5mm from the cupboard door but 450mm overall clearance is still required, with the cupboard door open, to allow for servicing.

### \* Bottom clearance

Bottom clearance after installation can be reduced to 5mm. This must be obtained with an easily removable panel, to enable the consumer to view the system pressure gauge, and to provide the 100mm clearance required for servicing.

### REAR FLUE ONLY

MIN. Top clearance required = 165 mm

SIDE FLUE ONLY		
Horizontal length of flue from CL of boiler to outside wall		Top clearance required (MIN.) Dim. A
15,18,24	30	
0.5 m	0.5 m	165 mm
1.0 m	1.0 m	170 mm
1.5 m	1.5 m	185 mm
2.0 m	2.0 m	200 mm
2.5 m	2.5 m	210 mm
3.0 m	3.0 m	225 mm
3.5 m	3.5 m	250 mm
4.0 m	4.0 m	260 mm
4.5 m	4.5 m	265 mm
5.0 m	5.0 m	275 mm
5.5 m	5.5 m	290 mm
6.0 m	6.0 m	300 mm
6.5 m	6.5 m	320 mm
7.0 m	7.0 m	330 mm
7.5 m	7.5 m	345 mm
8.0 m	8.0 m	360 mm
8.5m	N/A	370 mm
9.0 m	N/A	385 mm

# GENERAL

## 2 SYSTEM REQUIREMENTS - Central Heating

### Notes

- a. The method of filling, refilling, topping up or flushing sealed primary hot water circuits from the mains via a temporary hose connection is only allowed if acceptable to the local water authority.
- b. Antifreeze fluid, corrosion and scale inhibitor fluids suitable for use with boilers having aluminium heat exchangers may be used in the central heating system.

### General

1. The installation must comply with all relevant national and local regulations.
2. The installation should be designed to work with flow temperatures of up to 86 °C.
3. All components of the system must be suitable for a working pressure of 3 bar and temperature of 110 °C. Extra care should be taken in making all connections so that the risk of leakage is minimised.

The following components are incorporated within the appliance:

- a. Circulating pump.
- b. Safety valve, with a non-adjustable preset lift pressure of 3 bar.
- c. Pressure gauge, covering a range of 0 to 4 bar.
- d. An 8-litre expansion vessel, with an initial charge pressure of 0.75 bar.

4. **'Make-up' Water.** Provision must be made for replacing water loss from the system, either :

- a. From a manually filled 'make-up' vessel with a readily visible water level. The vessel should be mounted at least 150mm above the highest point of the system and be connected through a non-return valve to the system, fitted at least 150mm below the 'make-up' vessel on the return side of the radiators. **or**
- b. Where access to a 'make-up' vessel would be difficult, by pre-pressurisation of the system.

The maximum cold water capacity of the system should not exceed 143 litres, if not pressurized. However, if the system is to be pressurized, the efficiency of the expansion vessel will be reduced and a larger vessel (or smaller system volume) may be necessary. If the capacity of the vessel is not considered sufficient for this, or for any other reason, an additional vessel **MUST** be installed on the return to the boiler.

Guidance on vessel sizing is given in table opposite.

### 5. Filling

The system may be filled by the following method:

Through a temporary hose connection from a 'draw-off' tap, supplied from a service pipe under mains pressure. Where the mains pressure is excessive, a pressure reducing valve must be used to facilitate filling. When installing the filling device, it must be connected as below to fully comply with the water regulations.

This may involve the fitting of an additional WRAS approved isolator valve to the mains supply.

- i. Thoroughly flush out the whole system with cold water.
- ii. Fill and vent the system until the pressure gauge registers 1.5 bar, and examine for leaks.
- iii. Check the operation of the safety valve by raising the water pressure until the valve lifts. This should occur within 0.3 bar of the preset lift pressure.
- iv. Release water from the system until the minimum system design pressure is reached; 1.0 bar if the system is to be pre-pressurised.

<b>Safety valve setting</b>	bar	3.0	
<b>Vessel charge pressure</b>	bar	0.5 to 0.75	
<b>System pre-charge pressure</b>	bar	None	1.0
<b>System volume (litres)</b>		<b>Expansion vessel volume (litres)</b>	
	25	1.6	1.8
	50	3.1	3.7
	75	4.7	5.5
	100	6.3	7.4
	125	7.8	9.2
	150	9.4	11.0
	175	10.9	12.9
	190	11.9	14.0
	200	12.5	14.7
	250	15.6	18.4
	300	18.8	22.1
<b>For other system volumes multiply by the factor across</b>		0.063	0.074

Model	15	18	24	30
Max CH output kW (Btu/h)	15 (51,300)	18 (61,600)	24.2 (82,600)	30.3 (103,300)
Water flow rate l/min (gal/min)	10.7 (2.4)	13 (2.8)	17.2 (3.8)	21.5 (4.7)
Temp differential °C (°F)	20 (36)	20 (36)	20 (36)	20 (36)
Head available for system m.w.g. (ft.w.g.)	5 (16.2)	4.5 (14.7)	3.3 (10.8)	1.9 (6.2)

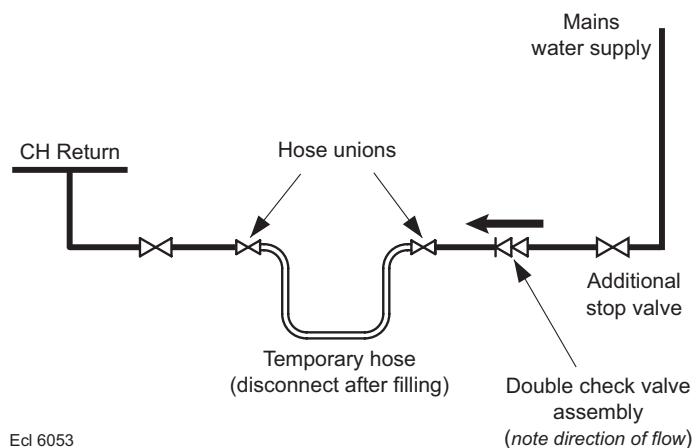

## GENERAL

### 3 SYSTEM BALANCING

The boiler does not normally need a bypass but at least some radiators on the heating circuit, of load of at least 10% of the minimum boiler output, must be provided with twin lockshield valves so that this minimum heating load is always available. See note regarding thermostatic radiator valves on page 9.

**Note.** *Systems incorporating zone valves which could completely cut off the flow through the system must also include a bypass.*

#### BALANCING

1. Set the programmer to ON.

Close the manual or thermostatic valves on all radiators, leaving the twin lockshield valves (on the radiators referred to above) in the OPEN position.

Turn up the room thermostat and adjust the lockshield valve to give an uninterrupted flow through the radiator.

These valves should now be left as set.

2. Open all manual or thermostatic radiator valves and adjust the lockshield valves on the remaining radiators, to give

around 20°C temperature drop at each radiator.

3. Adjust the room thermostat and programmer to NORMAL settings.

### 4 WATER TREATMENT

#### CENTRAL HEATING

The Logic System range of boilers have an ALUMINIUM alloy heat exchanger.

#### IMPORTANT.

The application of any other treatment to this product may render the guarantee of Ideal Stelrad Group Invalid.

Ideal Stelrad Group recommend Water Treatment in accordance with the Benchmark Guidance Notes on Water Treatment in Central Heating Systems.

If water treatment is used **Ideal Stelrad Group** recommend only the use of Scalemaster Gold 100, FERNOX, MBI or SENTINEL X100 inhibitors and associated water treatment products, which must be used in accordance with the manufacturers' instructions.

#### Notes.

1. *It is most important that the correct concentration of the water treatment products is maintained in accordance with the manufacturers' instructions.*
2. *If the boiler is installed in an existing system any unsuitable additives MUST be removed by thorough cleansing. BS 7593:2006 details the steps necessary to clean a domestic heating system.*
3. *In hard water areas, treatment to prevent lime scale may be necessary - however the use of artificially softened water is NOT permitted.*
4. *Under no circumstances should the boiler be fired before the system has been thoroughly flushed.*

For further information contact:

Fernox Manufacturing Co. Ltd  
Cookson Electronics  
Forsyth Road  
Sheerwater  
Woking  
Surrey GU21 5RZ  
+44 (0) 1799 521133

Sentinel Performance Solutions  
The Heath Business & Technical Park  
Runcorn  
Cheshire WA7 4QX  
Tel: 0800 389 4670  
[www.sentinel-solutions.net](http://www.sentinel-solutions.net)

Scalemaster Water Treatment Products  
Emerald Way  
Stone  
Staffordshire ST15 0SR  
Tel: +44 (0) 1785 811636

Calmag Ltd.  
Unit 4-6, Crown Works  
Bradford Road  
Sandbeds, Keighley  
West Yorkshire BD20 5LN  
Tel: +44 (0) 1535 210 320

# GENERAL

## 5 BOILER ASSEMBLY - Exploded View

Note that item numbers are linked to the spares list

104	CH RETURN VALVE	206	PIPE - GAS INJECTOR	303	CUI BOARD
105	CH FLOW VALVE	211	INJECTOR ASSEMBLY	304	CONTROL THERMISTOR (RETURN)
108	PUMP HEAD	214	VENTURI	306	ELECTRODE IGNITION
110	PUMP AUTO AIR VENT	215	FAN	307	ELECTRODE DETECTION
113	PRESSURE RELIEF VALVE	217	BURNER	308	IGNITER UNIT
114	PIPE - PRV OUTLET	218	GASKET - BURNER	309	THERMISTOR CONTROL/NO FLOW
115	PIPE - FLOW	219	SUMP CLEAN OUT COVER	313	IGNITION LEAD
116	PIPE - RETURN	223	FLUE MANIFOLD	314	CONTROL BOX LENS
117	PIPE - EXPANSION VESSEL	224	FLUE MANIFOLD TOP	324	CONTROLS BOX LID
118	EXPANSION VESSEL	227	CLAMP RETAINING FLUE TURRET	325	CONTROL BOX FRONT
120	FLOW GROUP MANIFOLD	228	HOSE CONDENSATE INTERNAL	401	HEAT ENGINE
121	BY-PASS KIT	229	SIPHON TRAP	503	WALL MOUNTING BRACKET
131	WATER PRESSURE TRANSDUCER	230	SIPHON TRAP CAP & SEAL	504	FRONT PANEL
135	PRESSURE GAUGE	231	CONDENSATE OUTLET CONNECTION	505	FASCIA
203	GAS COCK	233	FLUE SENSING NIPPLE	506	BRACKET - GAS VALVE
204	PIPE - GAS INLET	301	CONTROLS BOX FIXINGS HINGE & SPRING	507	BRACKET - EXPANSION VESSEL
205	GAS VALVE	302	PRIMARY PCB*		

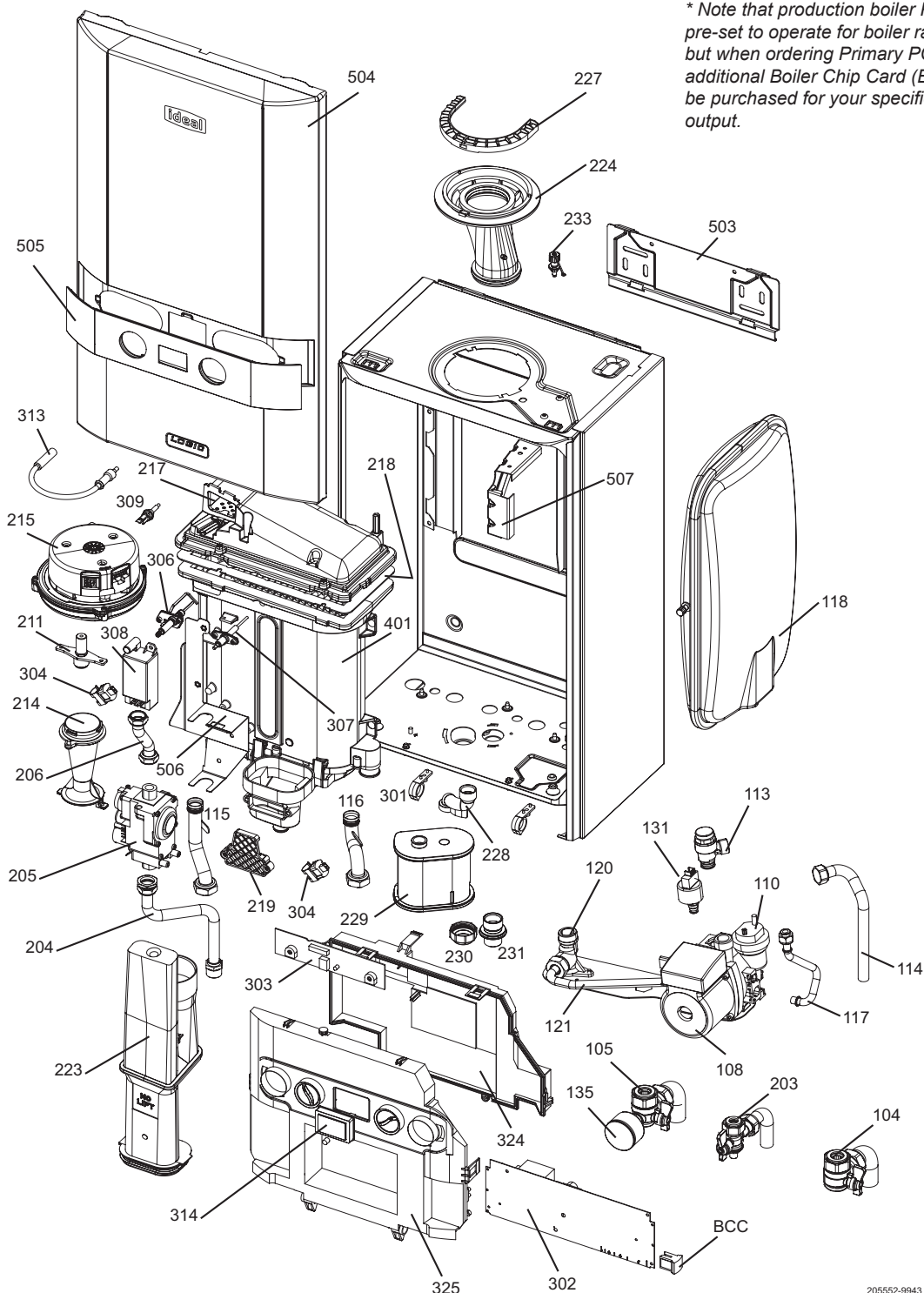

\* Note that production boiler PCBs are factory pre-set to operate for boiler range and output, but when ordering Primary PCB as a spare, an additional Boiler Chip Card (BCC) MUST also be purchased for your specific boiler range and output.

20552-9943

# INSTALLATION

## 6 UNPACKING

The boiler is supplied fully assembled in one Pack A, together with a telescopic flue assembly for lengths up to 595mm, rear or side flue outlet, in Pack B.

### Unpack and check the contents.

#### Pack A Contents

- A Boiler
- B Hardware Pack Box
- C Wall Mounting Plate
- D These Installation/Users Instructions
- E Wall Mounting Template (located on internal protective packaging)
- F Turret Clamp
- G Boiler Guarantee & Registration Pack

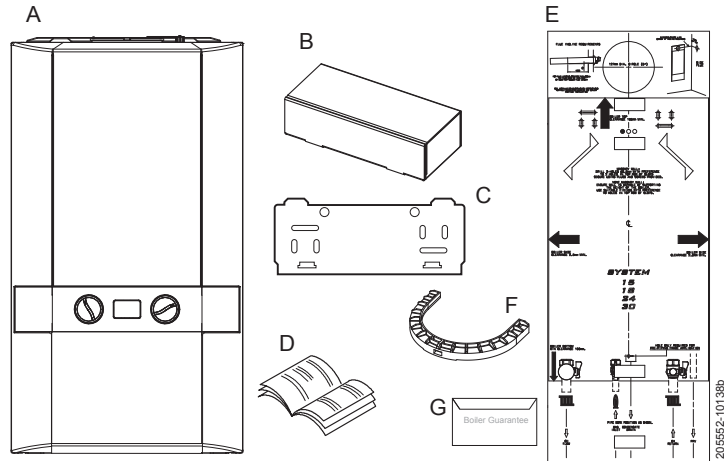

### HARDWARE PACK CONTENTS

#### Gas Valve Pack

- 1. Pipe - Gas Inlet
- 2. Washer - Gas (blue)
- 3. Gas Cock

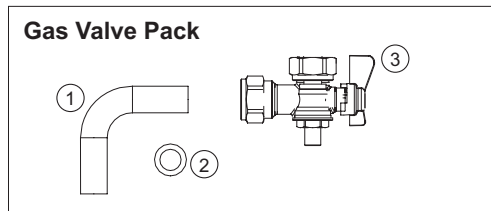

#### Accessory Pack

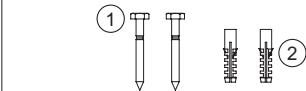

#### Return Valve Pack

- 1. Pipe CH Return
- 2. Washer CH
- 3. Valve Return

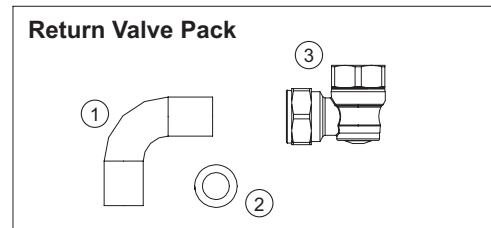

#### Flow Valve Pack

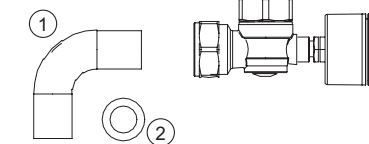

#### Accessory Pack

- 1. Screw (x2)
- 2. Wallplug (x2)

#### Flow Valve Pack

- 1. Pipe CH Flow
- 2. Washer CH
- 3. Valve Flow (with gauge)

3G9945

### Pack B Contents Non-Telescopic

- A Flue terminal
- B Flue turret
- C Rubber terminal wall seal
- D Cutting Aid

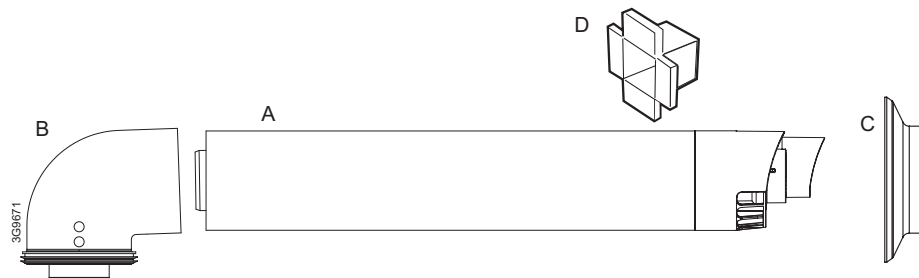

### Pack B Contents Telescopic

- A Telescopic flue terminal
- B Flue turret
- C Rubber terminal wall seal
- D Screw
- E Sealing Tape

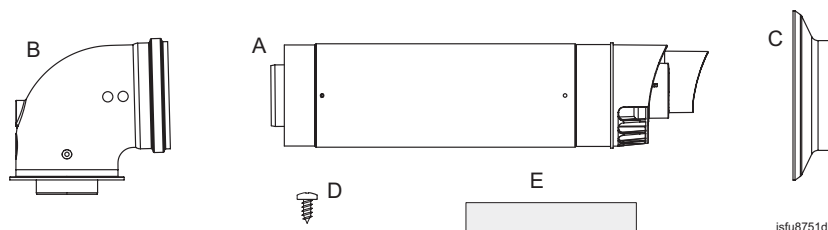

isfu8751d

# INSTALLATION

## 7 FRONT PANEL REMOVAL

1. Loosen the 2 screws retaining the front panel.
2. Pull the two spring clips downwards to disengage.
3. Pull the front panel forward and upwards to remove.

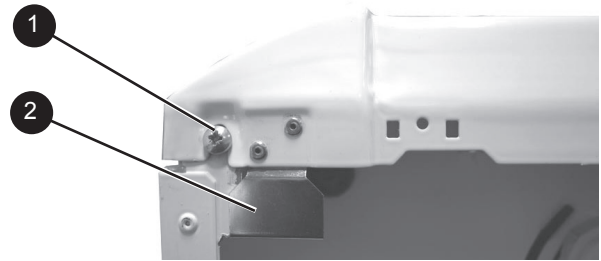

## 8 DETERMINING THE FLUE LENGTH AND FLUE PACKS REQUIRED

**IMPORTANT.** The boiler MUST be installed in a vertical position

### FLUE KITS

**Pack B** - supplied as standard

**Pack B** - optional telescopic

**Pack D** - optional extension kit for side flue or rear flue outlet.

**Concentric Flue Retaining Kit** - Optional Kit for mechanical fixing of flue joints

**Finishing Kit** - Supplied as an optional extra.

Refer to 'Flue Extension Ducts'

**Dimension X** - Wall thickness.

**Dimension L** - Wall thickness plus boiler spacing.

**Dimension S** - Optional stand-off frame depth 45mm.

**Note. MAXIMUM FLUE LENGTHS:**

15 - 9M (HORIZONTAL FLUE)

18 - 9M (HORIZONTAL FLUE)

24 - 9M (HORIZONTAL FLUE)

30 - 8M (HORIZONTAL FLUE)

15, 18, 24, 30 - 7.5M (ROOF FLUE)

15, 18, 24, 30 - 5M PRIMARY AND 17M SECONDARY IS A TYPICAL MAX.

**FLUE LENGTH.** (For alternative details refer to Powered Vertical Instructions)

90° ELBOW KIT 60/100 (EQUIVALENT FLUE LENGTH RESISTANCE = 1M)

45° ELBOW KIT 60/100 (EQUIVALENT FLUE LENGTH RESISTANCE = 0.6M)

**MINIMUM HORIZONTAL FLUE LENGTHS** - TELESCOPIC TERMINAL = 350MM

(Centre Line of turret to outside of wall terminal) - ONE PIECE TERMINAL = 285MM

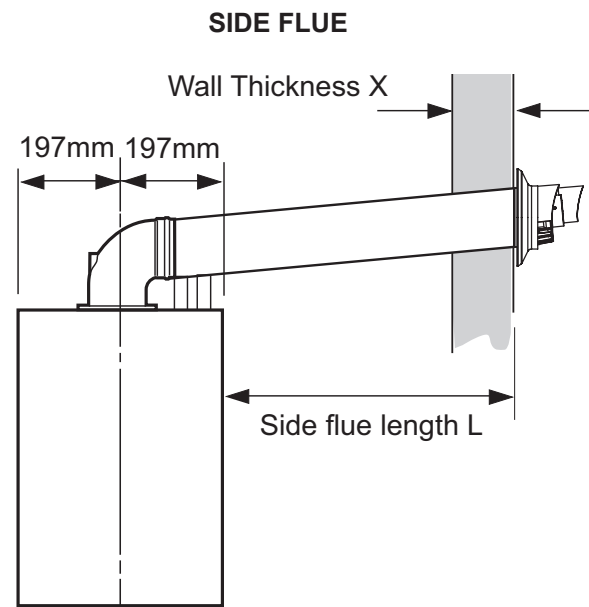
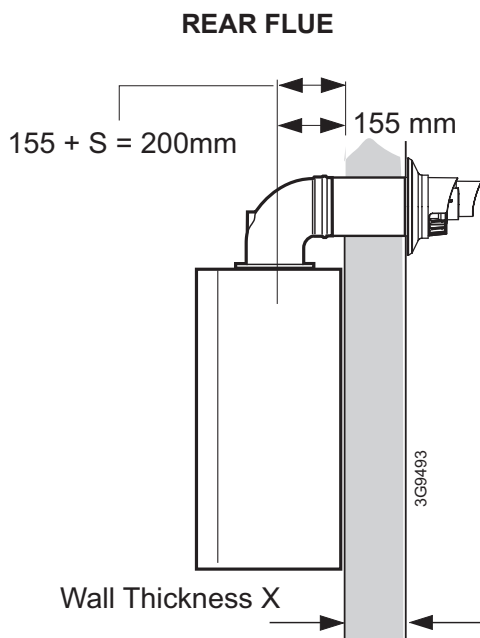

continued . . . . .

FLUE OUTLET

# INSTALLATION

## 9 DETERMINING THE FLUE LENGTH AND FLUE PACKS REQUIRED CONT'D

### Notes.

1. It is recommended that a support bracket is fitted for every 1 metre of extension pipe used and a bracket should be used at every joint, to ensure pipes are held at the correct angle.

If a slip joint coupling is to be used then a bracket should be used to secure the collar.

2. When extension 'D' packs are used the flue duct MUST be inclined at 1.5 degrees to the horizontal to allow condensate to drain back into the boiler and out through the condensate drain.

3. If the B pack, or telescopic B pack only are used, they may be mounted horizontally. The 1.5 degrees is taken care of by the inclination of the flue within the air pipe.

4. Only use water as a lubricant during assembly.

### NON - TELESCOPIC FLUE

Total Flue length dimension (measuring from CL of turret to outside wall)		Flue	
Rear flue dim. X+155	Side flue dim. L+197	Extra packs required	Boiler Size
Up to 640 mm	Up to 640 mm	none	15, 18, 24, 30
Up to 1590 mm	Up to 1590 mm	Pack D - 1 off	15, 18, 24, 30
Up to 2540 mm	Up to 2540 mm	Pack D - 2 off	15, 18, 24, 30
Up to 3490 mm	Up to 3490 mm	Pack D - 3 off	15, 18, 24, 30
Up to 4440 mm	Up to 4440 mm	Pack D - 4 off	15, 18, 24, 30
Up to 5390 mm	Up to 5390 mm	Pack D - 5 off	15, 18, 24, 30
Up to 6340 mm	Up to 6340 mm	Pack D - 6 off	15, 18, 24, 30
Up to 7290 mm	Up to 7290 mm	Pack D - 7 off	15, 18, 24, 30
Up to 8240 mm	Up to 8240 mm	Pack D - 8 off	15, 18, 24, 30*
Up to 9000 mm	Up to 9000 mm	Pack D - 9 off	15, 18, 24

\* Logic System 30 is capable of 8m flue only

### TELESCOPIC FLUE

Total Flue length dimension (measuring from CL of turret to outside wall)		Flue	
Rear flue dim. X+155	Side flue dim. L+197	Extra packs required	Boiler Size
Up to 575 mm	Up to 575 mm	none	15, 18, 24, 30
Up to 1525 mm	Up to 1525 mm	Pack D - 1 off	15, 18, 24, 30
Up to 2475 mm	Up to 2475 mm	Pack D - 2 off	15, 18, 24, 30
Up to 3425 mm	Up to 3425 mm	Pack D - 3 off	15, 18, 24, 30
Up to 4375 mm	Up to 4375 mm	Pack D - 4 off	15, 18, 24, 30
Up to 5325 mm	Up to 5325 mm	Pack D - 5 off	15, 18, 24, 30
Up to 6275 mm	Up to 6275 mm	Pack D - 6 off	15, 18, 24, 30
Up to 7225 mm	Up to 7225 mm	Pack D - 7 off	15, 18, 24, 30
Up to 8175 mm	Up to 8175 mm	Pack D - 8 off	15, 18, 24, 30*
Up to 9000 mm	Up to 9000 mm	Pack D - 9 off	15, 18, 24

\* Logic System 30 is capable of 8m flue only

## 10 FLUE ASSEMBLY - Exploded View

An optional flue duct extension kit is required for wall thicknesses greater than :

Side 378mm

Rear 420mm

### LEGEND

1. Duct assembly.
2. Flue turret.
3. Turret clamp.

Telescopic B Pack shown

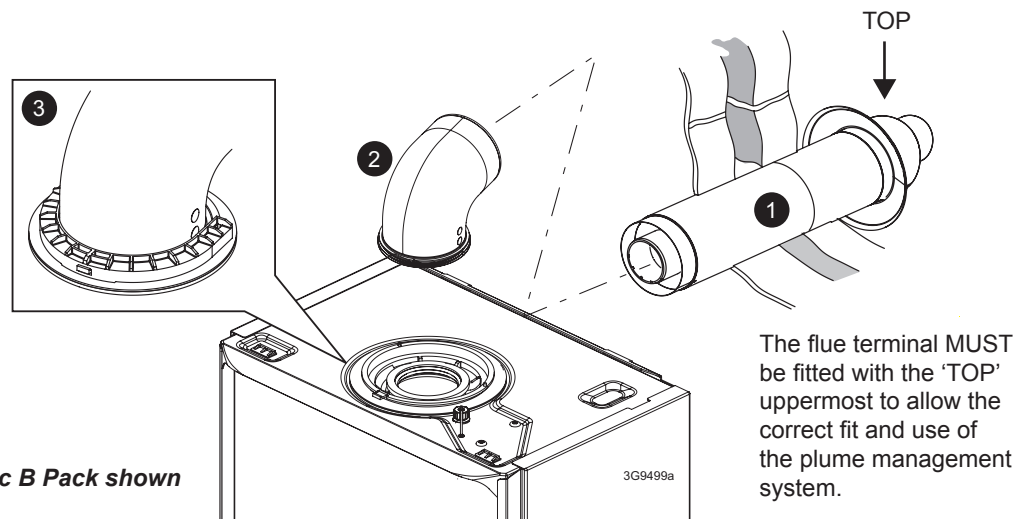

The flue terminal MUST be fitted with the 'TOP' uppermost to allow the correct fit and use of the plume management system.



# INSTALLATION

## 11 WALL MOUNTING TEMPLATE

The wall mounting template is located on the internal protective packaging.

**Note.**

The template shows the positions of the fixing holes and the rear flue hole centre for standard installation. Care MUST be taken to ensure the correct holes are drilled.

1. Tape template into the selected position. Ensure squareness by hanging a plumbline as shown.
2. If fitting a side flue extend the flue centre line onto the side wall and measure in 155mm for standard installation.
3. Mark onto the wall the following:
  - a. The wall mounting plate screw positions (choose one from each group).
  - b. The position of the flue duct hole (see diagram below).

**Note.** Mark the centre of the hole as well as the circumference.

4. Remove the template from the wall.

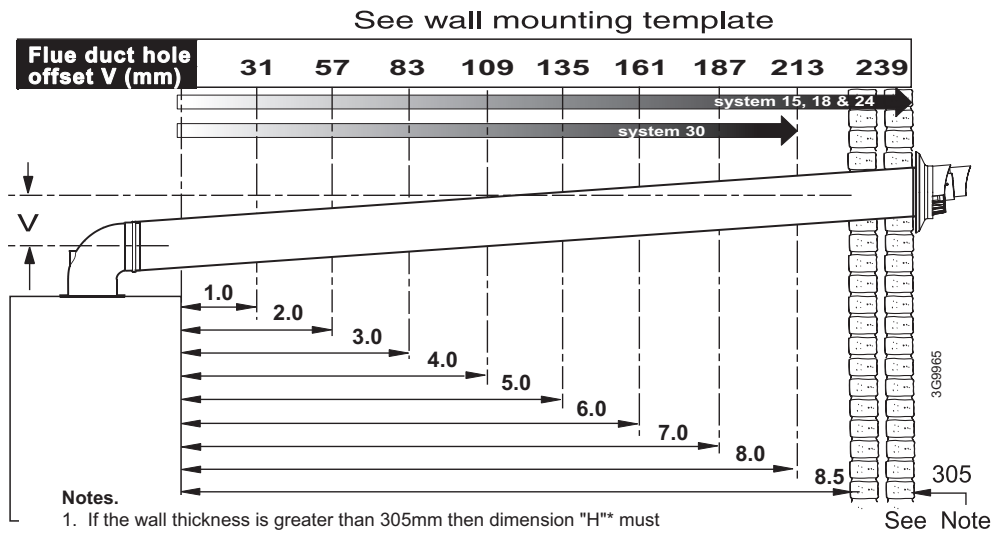
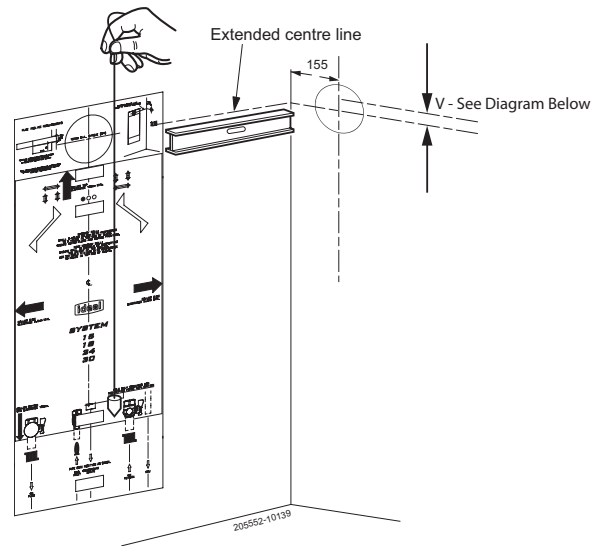

**Notes.**

1. If the wall thickness is greater than 305mm then dimension "H"\* must be reduced by the same amount and the offset may be adjusted accordingly.
  2. For flue lengths greater than 600mm the flue must be inclined by 26mm per 1000mm flue length.
- \* "H" = Distance in metres from side of the boiler to the side wall

## 12 PREPARING THE WALL

**IMPORTANT.**

Ensure that, during the cutting operation, masonry falling outside of the building does not cause damage or personal injury.

1. Cut the flue hole (preferably with a 5" core boring tool), ensuring that the hole is square to the wall. Both wall faces immediately around the cut hole should be flat.
2. Drill 2 holes with a 7.5mm / 8mm masonry drill and insert the plastic plugs, provided, for the wall mounting plate.
3. Locate 2 No.14 x 50mm screws in the wall mounting plate (one at each side, in any of the 3 holes provided at each side) and screw home.

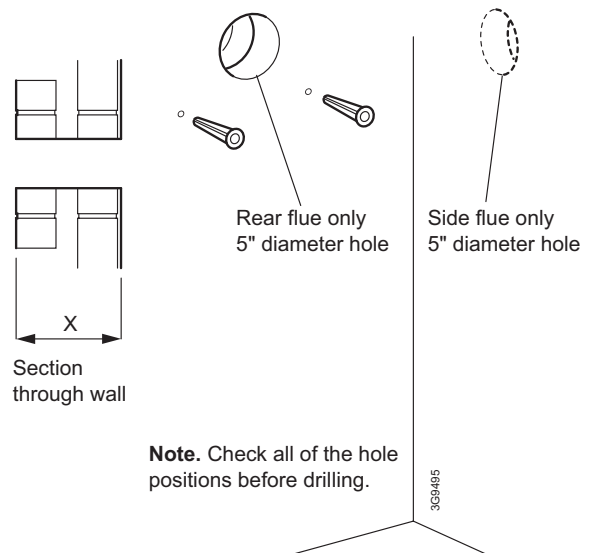

FLUE OUTLET

# INSTALLATION

## 13 TERMINAL WALL SEAL ASSEMBLY / POSITIONING

Prior to fitting the flue, the rubber terminal wall seal provided in the flue pack **MUST** be fitted to the flue terminal as shown below in Figure 1.

Once the flue is installed it is **IMPORTANT** that the rubber terminal wall seal is pressed against the outside wall to create an adequate seal between the flue and wall as shown in Figure 2.

FIGURE 1

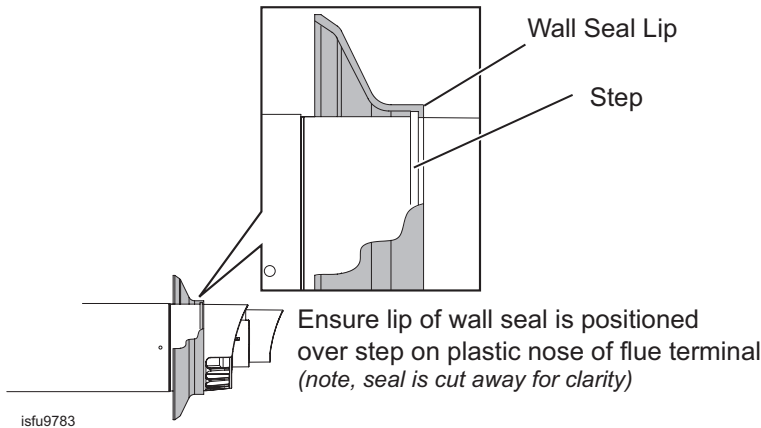
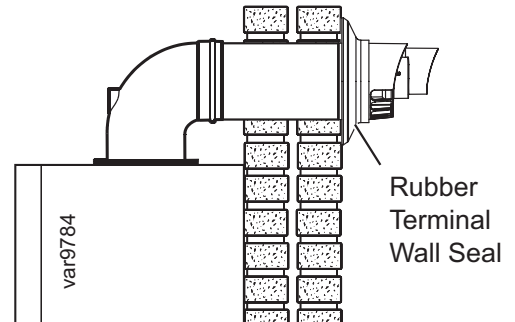

FIGURE 2



## 14 SETTING THE FLUE - REAR

### NON TELESCOPIC FLUE - Wall thickness of 115mm to 485mm

**Notes.**

- a. If using the extension ducts go to Frame 16.
- b. If the stand-off frame is used it is essential to add 45mm to 'X' the measured wall thickness when marking the flue (this will allow for the fitted frame).

1. Measure and note wall thickness X. Refer to Frames 8 & 9.
2. Add 90mm to dimension X and, measuring from the ring, cut the outer tube only.
3. To ensure the tube is cut square, mark the flue all the way around.
4. Cut the inner tube to a length 20mm longer to aid engagement, using the cutting aid provided.

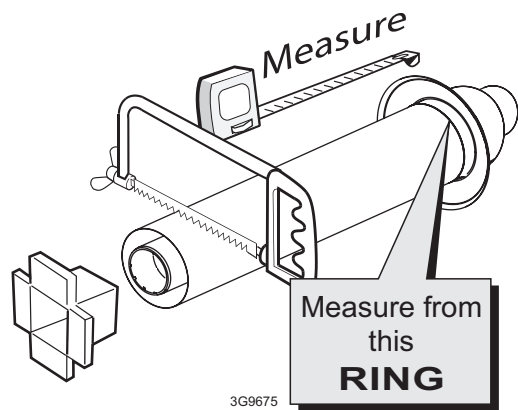

### TELESCOPIC FLUE - Wall thickness of 195mm to 420mm

**Notes.**

- a. If using the extension ducts go to Frame 16.
- b. For shorter flue requirements use non telescopic B Pack.
- c. If the stand-off frame is used it is essential to add 45mm to 'X' the measured wall thickness when marking the flue (this will allow for the fitted frame).

1. Measure and note wall thickness X. Refer to Frames 8 & 9.
2. Add 75mm to dimension X and set telescopic flue length as indicated in drawing.
3. Using a 3.5mm drill bit, drill one hole in outer air duct taking care not to pierce plastic inner flue.
4. Fix to length using self tappers provided.
5. Seal outer air duct using the tape provided.

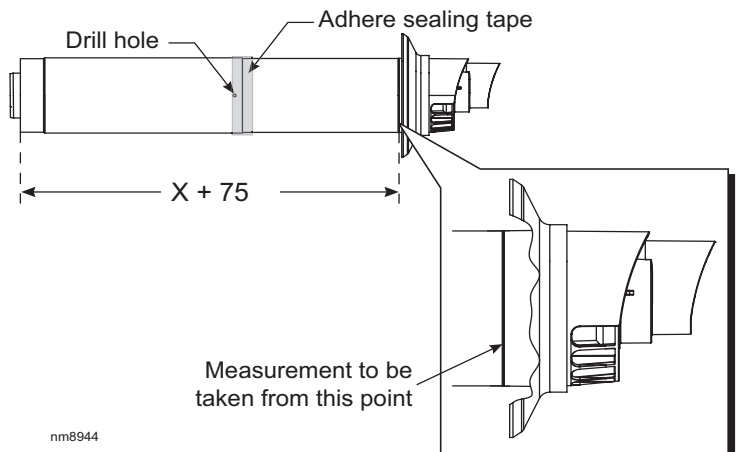

FLUE OUTLET

# INSTALLATION

## 15 SETTING THE FLUE - SIDE

Wall thicknesses of 148 to 378mm

### NON TELESCOPIC FLUE - Wall thickness of 115mm to 440mm

**Notes.**

If using the extension ducts go to Frame 16.

1. Measure and note side flue length L. Refer to Frame 10.
2. Add 125mm to dimension L and, measuring from the ring, cut the outer tube only.
3. To ensure the tube is cut square, mark the flue all the way around.
4. Cut the inner tube to a length 20mm longer to aid engagement, using the cutting aid provided

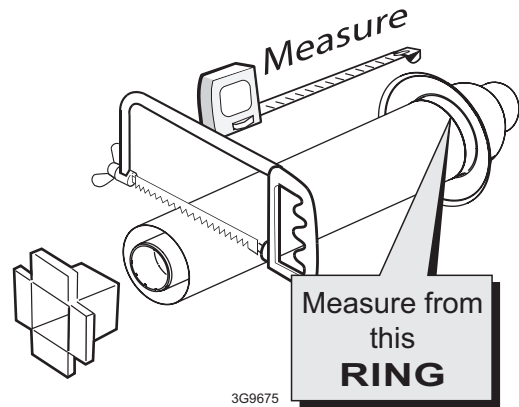

### TELESCOPIC FLUE - Wall thickness of 150mm to 375mm

**Notes.**

- a. If using the extension ducts go to Frame 16.
- b. For shorter flue requirements use non telescopic B Pack.

1. Measure and note wall thickness X. Refer to Frames 8 & 9.
2. Measure distance from side of boiler to inside of wall and add to wall thickness  $X=L$ . Refer to Frame 9.
3. Add 115mm to dimension L and set telescopic flue length as indicated in drawing.
4. Using a 3.5mm drill bit, drill one hole in outer air duct taking care not to pierce plastic inner flue.
5. Fix to length using self tappers provided.
6. Seal outer air duct using the tape provided.

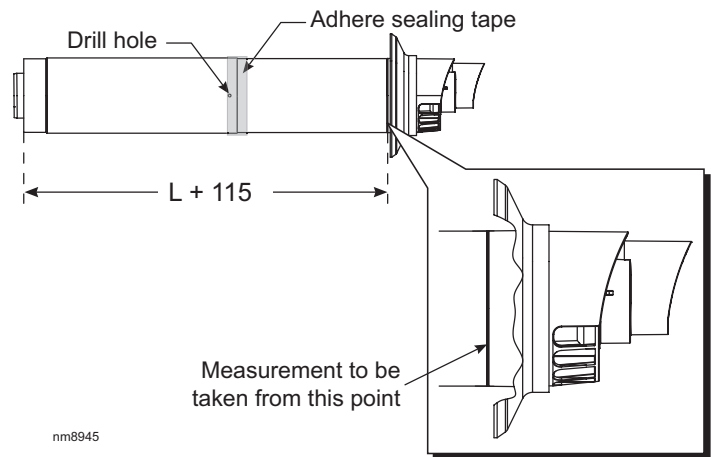

## 16 FLUE EXTENSION DUCTS - For total flue lengths greater than 575mm

**Pack D Flue extension duct kit contents**

Extension duct & clamp  
1.0m (39") long

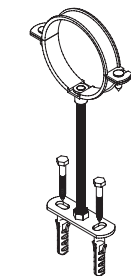
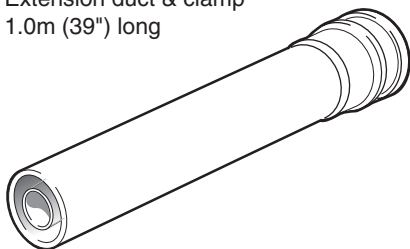

Flue support cutting aid  
(shown folded up)

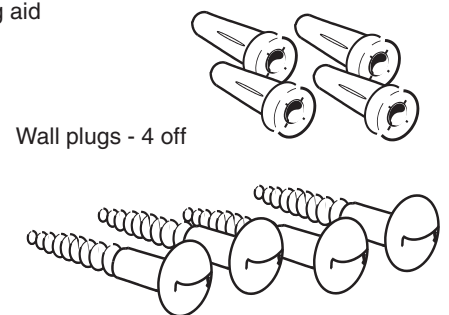
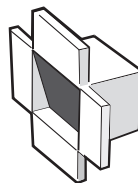

# INSTALLATION

## 17 FLUE EXTENSION DUCTS - continued

Use a maximum of 9m extended flue ONLY (15, 18 & 24)

Use a maximum of 8m extended flue ONLY (30)

### General arrangement

1. A **maximum** number of extension ducts are possible for each boiler output with one suitably cut.
  - 9 extension ducts for 15, 18 & 24
  - 8 extension ducts for 30Refer to Frame 9 for lengths
2. Flue extensions of greater length than 1m should be supported with the bracket provided, suitably adjusted. Refer to Frames 16.
3. Only use water as a lubricant during assembly. Do not use mineral based oils.

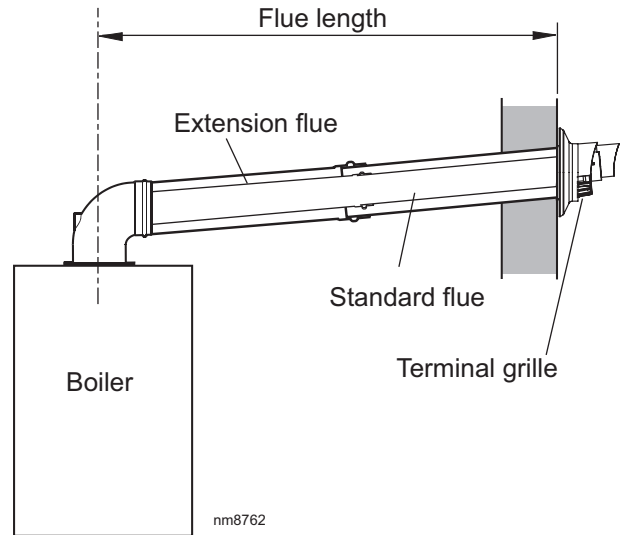

## 18 FITTING THE KIT

If the telescopic flue terminal is used it is not always necessary to cut an extension pack.

1. Measure the total flue length 'L' from the centre of the boiler outlet to the outside wall.
2. Subtract 65mm from this dimension.
3. Subtract 950mm for each 'D' pack to be used.
4. If the remainder Y is 300mm - 500mm this can be taken up by the adjustment in the telescopic flue.
5. If the remainder Y is 500mm - 950mm it will be necessary to use a further 'D' pack cut to 400mm.
6. If the remainder Y is less than 300mm, shorten the previous 'D' pack to suit required length and adjust the telescopic terminal.
7. Measure and mark the length on the flue, to ensure a square cut mark the flue all the way around and cut to length.

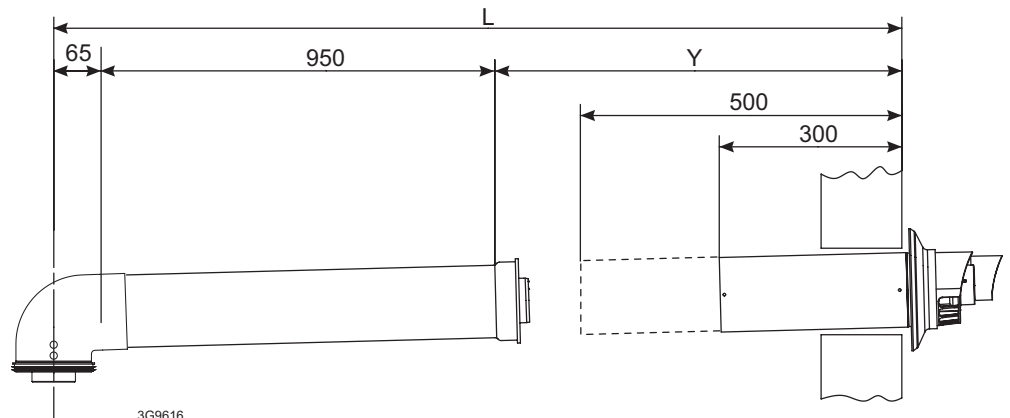

# INSTALLATION

## 19 FITTING THE WALL MOUNTING PLATE

Screw the wall mounting plate to the wall using 2 wall plugs (previously fitted) with the 2 screws provided.

Choose one of the 2 sets of slots in left and right bank. Ensuring that at least one of the screws is fitted into a top slot.

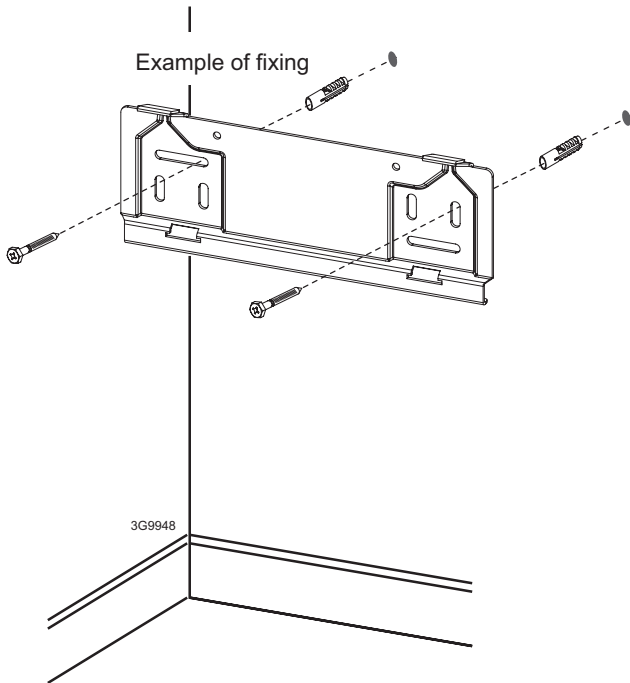

## 20 MOUNTING THE BOILER

1. Ensure the plastic plug is removed from the CH connections before mounting the boiler.
2. Lift the boiler onto the wall mounting plate (refer to the Introduction section for safe handling advice), locating it over the two tabs.

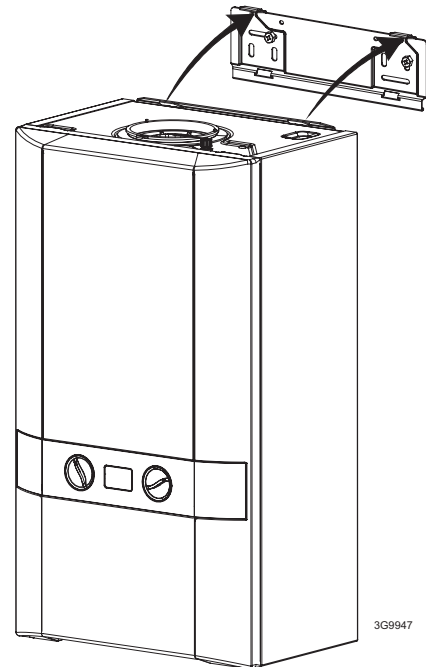

## 21 CONDENSATE DRAIN

Ensure that the siphon is full of water before commissioning the boiler.

The routing of the drain must be made to allow a minimum fall of 1 in 20 away from the boiler, throughout its length.

The drainage pipework must be arranged so that obstruction (e.g. through freezing) of external drainage pipe does not give rise to spillage within the dwelling.

### IMPORTANT.

All pipework and fittings in the condensate drain system must be made of plastic. No other materials may be used.

The drain outlet on the boiler is standard 21.5mm overflow pipe and is suitable for either push fit or solvent weld applications. This size must not be reduced in any part of its length.

The boiler includes as standard, a 75mm condensate trap. The condensate trap also includes a siphon to reduce the possibility of freezing in the drain outlet.

If external condensate pipe run is greater than 3m then pipe should be 32mm nominal diameter. Consideration should be given to insulating external condensate pipe runs.

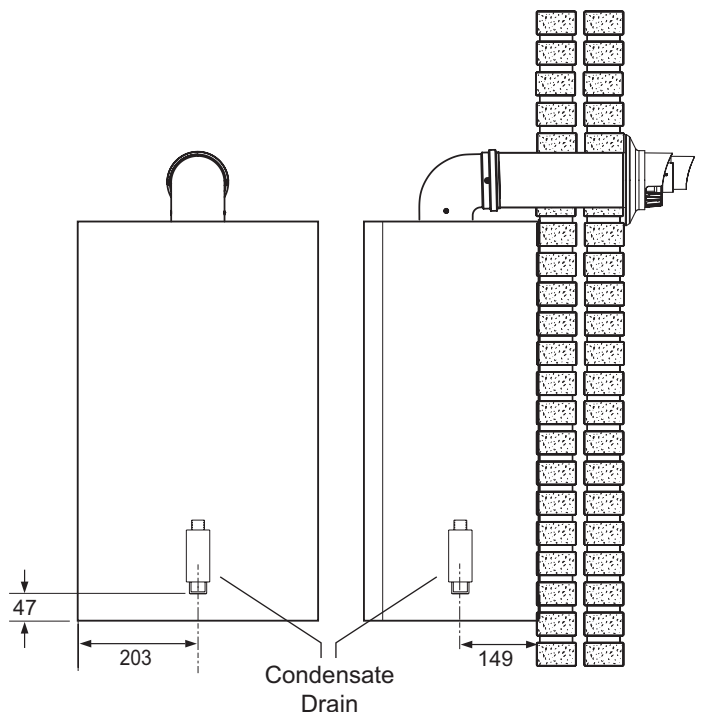

# INSTALLATION

## 22 CONDENSATE PIPE TERMINATION CONFIGURATIONS

Notes: ALL EXTERNAL PIPE RUNS MUST BE IN ACCORDANCE WITH BS 6798

### 1. INTERNAL TO SINK WASTE UPSTREAM OF SINK WASTE TRAP

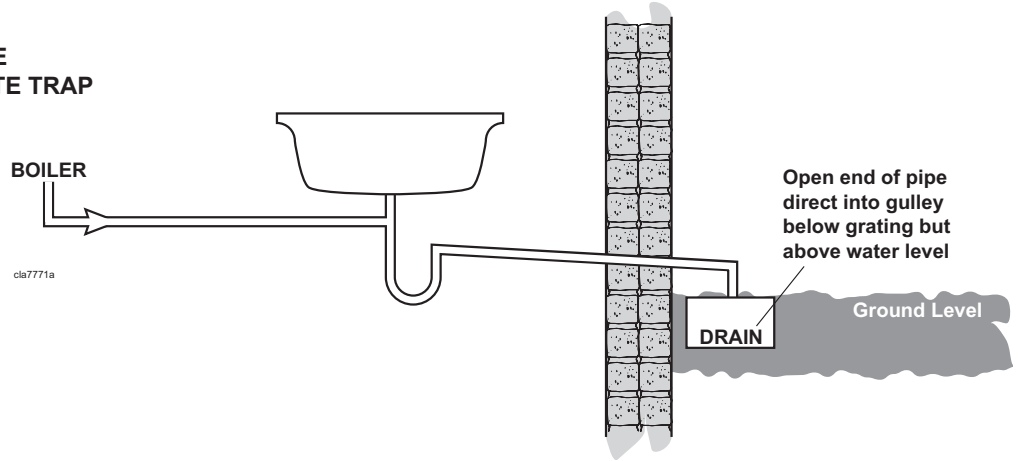

### 3. INTERNAL CONNECTION TO SOIL AND VENT STACK

\* Make connection to SVP using a solvent welded saddle

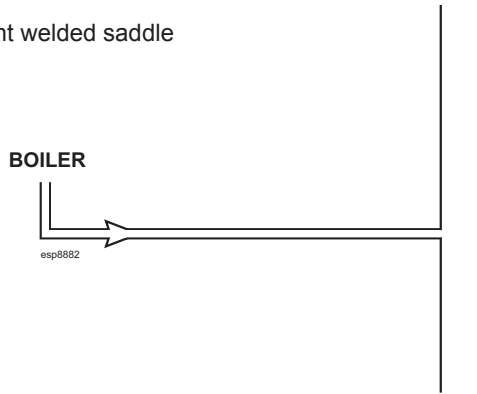

### 4. TERMINATION TO SOAK AWAY

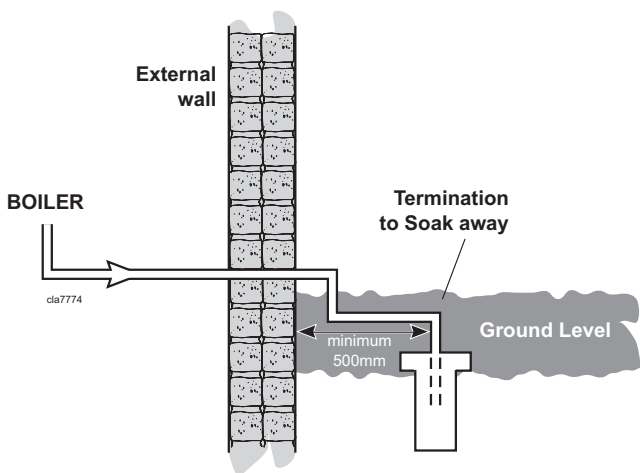

### 5. TERMINATION TO DRAIN / GULLY

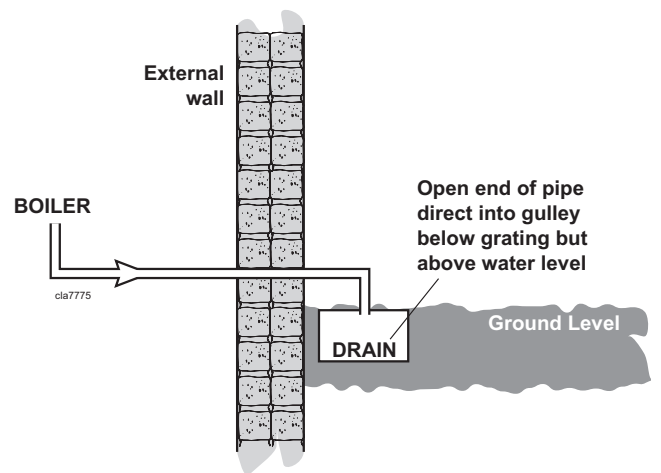

# INSTALLATION

## 23 CONNECTING THE FLUE TO THE BOILER

### Notes.

- Before fitting the flue turret fill the condensate trap within the boiler by pouring a cupful of water into the flue outlet (shown below). Take care to ensure that the water is only poured into the flue outlet, and does not spill into the boiler casing.
- During assembly check that flue seals do not become dislodged.

### NOTE. SIDE FLUE

Select flue orientation before inserting turret into boiler flue manifold.

DO NOT twist the turret once inserted.

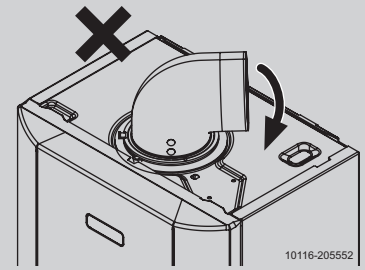

10116-205552

1. Ensure front panel is removed. Refer to Frame 7.
2. Locate the flue into the turret.
3. Insert the flue assembly through the prepared hole in the wall. Push through and pull back to seal against outside wall face.
4. Ensure rubber flue seal is present & fully engaged into plastic top flue manifold then locate the flue turret into the flue manifold and secure by applying downward pressure.
5. Engage the clamp in its slide mechanism and push it horizontally backwards
6. Locate BOTH plastic pegs BEFORE the front retaining clip is fully located.

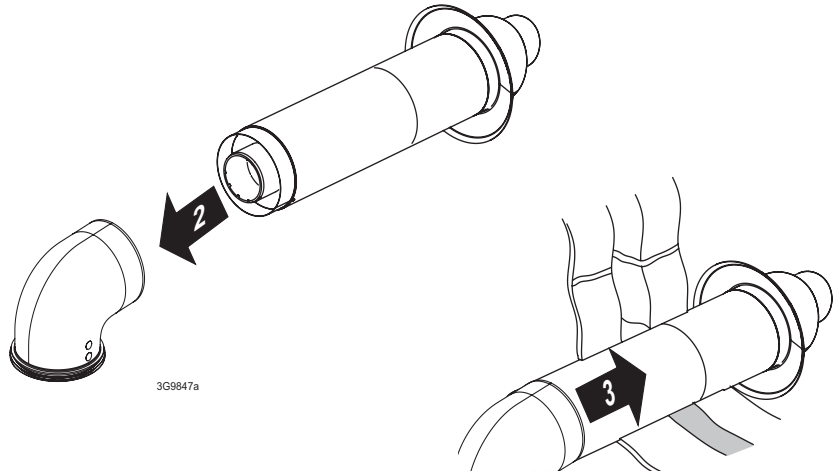

### Note - Flues over 1 metre long

It is recommended that a support bracket is fitted for every 1 metre of extension pipe used and a bracket should be used at every joint, to ensure pipes are held at the correct angle.

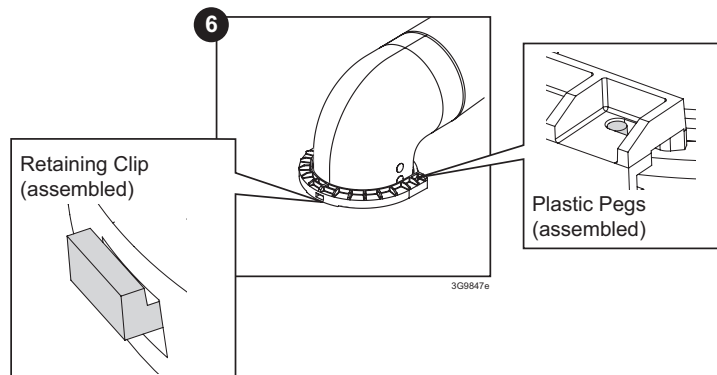
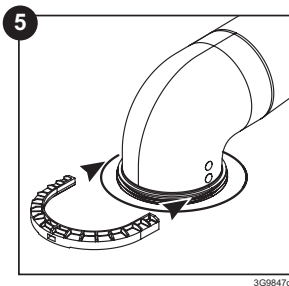
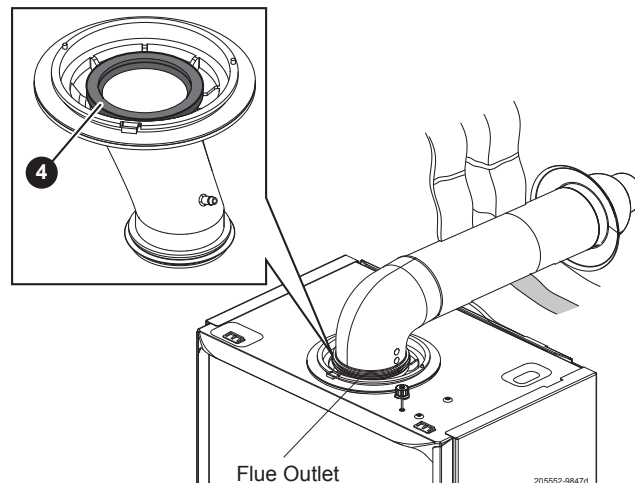

# INSTALLATION

## 24 FITTING THE OPTIONAL ROOF FLUE KIT (Flat or Pitched)

### Note.

A flat or pitched roof flashing plate (not supplied) is required before proceeding with the installation of this kit.

This kit is suitable for both flat and pitched roof terminations, using a concentric flue to run vertically from the top of the boiler and terminating above roof level.

Connection to the top of the boiler is made using a separately supplied vertical connector.

### WEATHER PROOFING

Where the flue passes through the roof line an adequate seal must be made. This is achieved by using either:

- Flat roof weather collar
- or
- Universal weather collar.

### ACCESSORIES

Flue Duct Extension Kits are available for flue lengths extending beyond 1m. These packs contain 1m extension ducts and may be cut to the desired length.

If the offset vertical option is used an elbow Kit is required. For a full accessories list refer to page 6, Optional Extras.

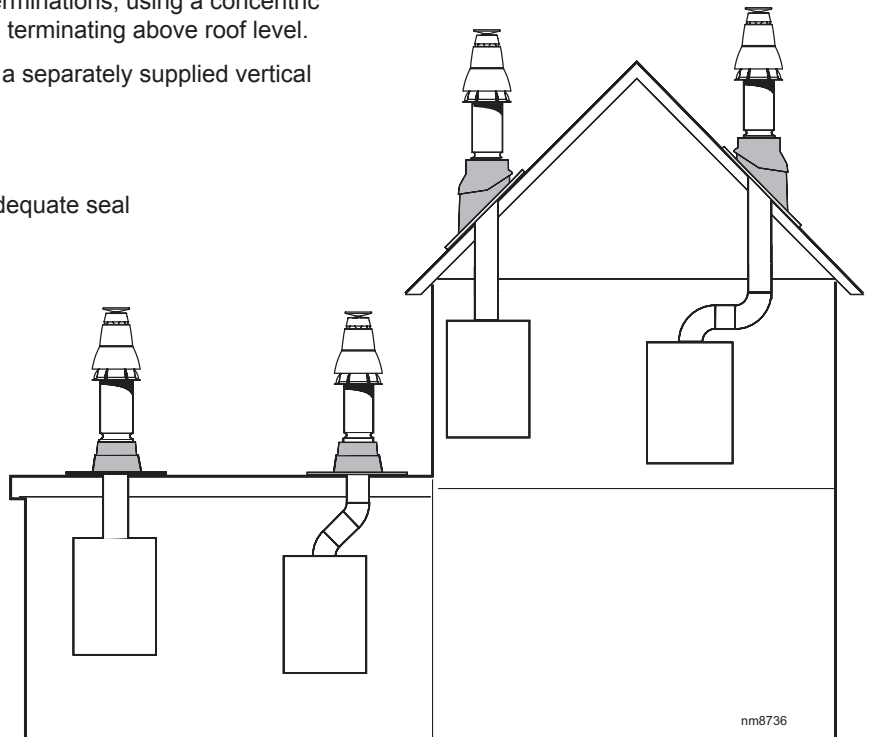

## 25 ROOF FLUE KIT CONTENTS / OPTIONS

Flue Terminal  
UIN 203132

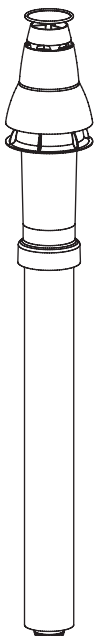

Flue Seal Collar - Flat Roof  
UIN 152259

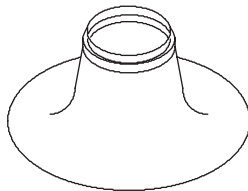

Vertical connector  
UIN 204645

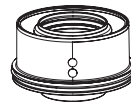

90° elbow  
UIN 203130



45° elbow  
UIN 203131

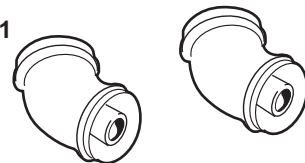

Flue Seal Collar - Tile Roof  
UIN 152258

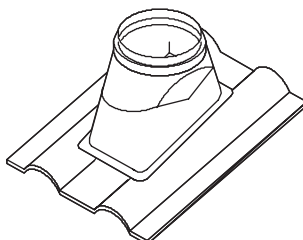

Roof Flue Extension Duct  
UIN 203129

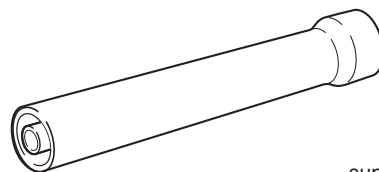

Flue duct support



Flue duct support

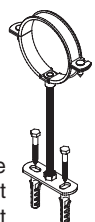

3G9626a



# INSTALLATION

## 26 FLUE TERMINAL POSITION

The terminal should be positioned so that products of combustion can safely disperse at all times.

Plumbing may occur at the termination so, where possible, terminal positions where this could cause a nuisance should be avoided.

Minimum dimensions are shown below

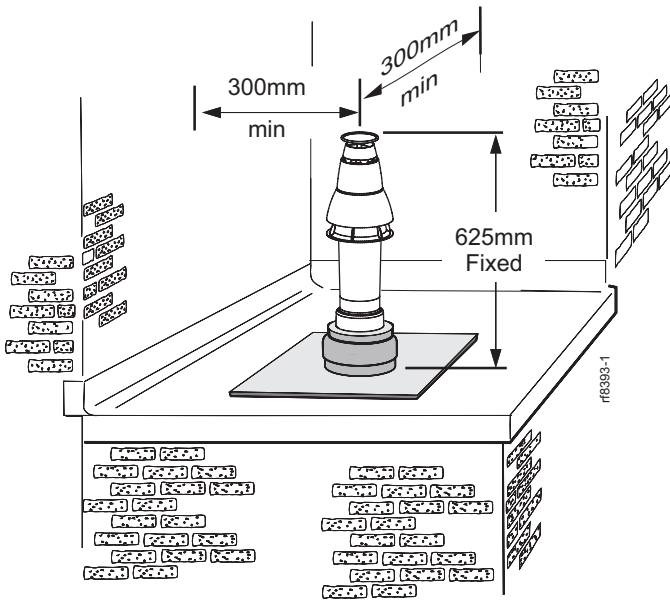

Flat roof - with structure

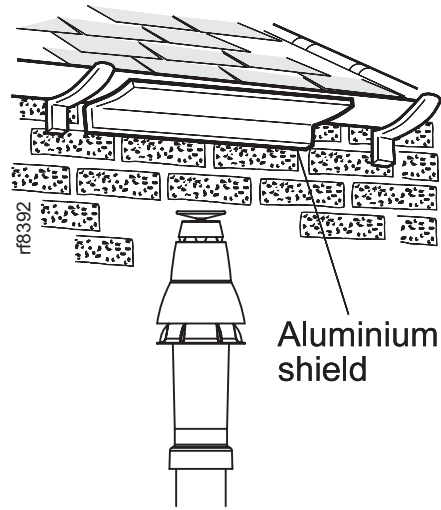

Aluminium shield

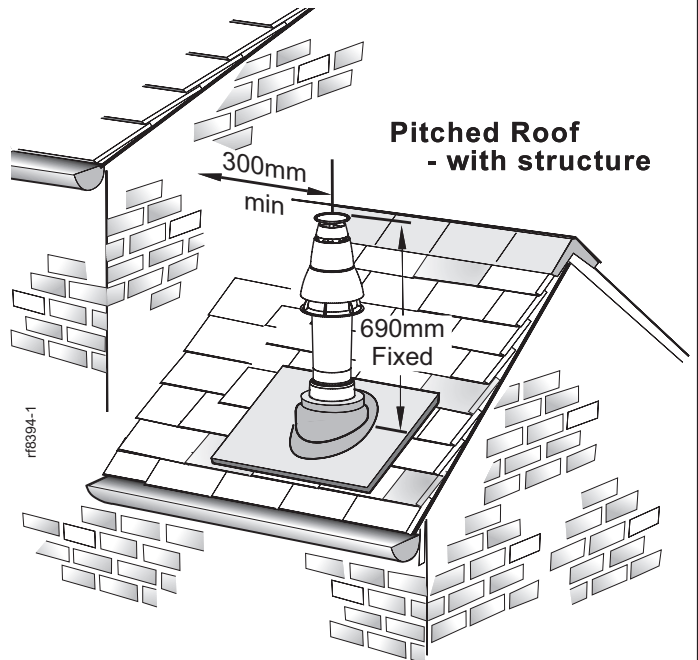

Pitched Roof - with structure

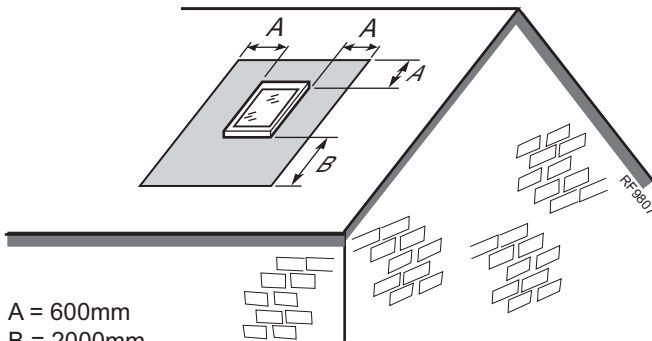

A = 600mm  
B = 2000mm

The flue terminal shall not penetrate the shaded area of the roof

Terminal Position	Minimum Dimension
Directly below an opening, air brick, windows, etc.	300 mm
Below plastic / painted gutters	300 mm
Painted surface	300 mm
Below eaves or balcony	500 mm
Below velux windows	2000mm
Above or side of velux windows	600mm

**Note.**

The equivalent flue length resistance of the elbow kits are:

90° elbow kit = 1m

45° elbow kit = 0.6m

FLUE OUTLET

# INSTALLATION

## 27 ASSEMBLING THE ROOF FLUE KIT

Determine the correct height that the flue should terminate above the roof. If after calculating or measuring the overall flue height from the top of the boiler, it is necessary to cut both pipes of assembly A, then ensure they are cut equally leaving the inner flue tube longer than the outer air tube as supplied.

Ensure the cut pipe ends are free from any burrs.

1. Position the roof flashing plate (supplied separately) over the hole cut in the roof and insert flue terminal from the roof end.

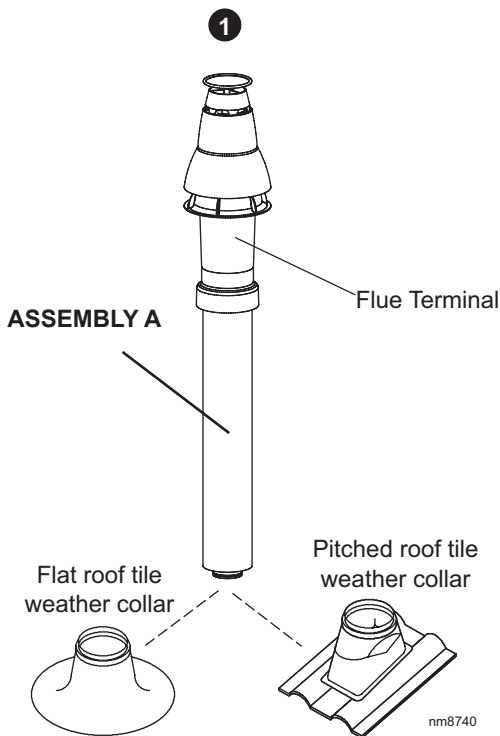
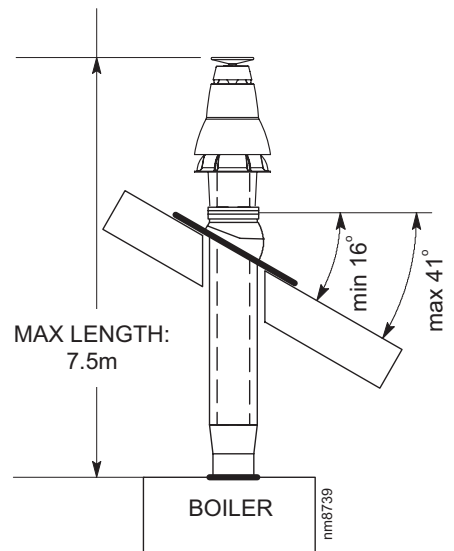

2. Fit the vertical connector (supplied separately) in accordance with the in the instructions provided with the vertical connector kit.
3. Secure the vertical connector by applying downward pressure on the connector.
4. Engage the clamp in its slide mechanism and push it horizontally backwards, locating on BOTH plastic pegs BEFORE the front retaining clip is fully located (as shown in Frame 23).
5. "Push" fit extension duct (if required (supplied separately)) into vertical connector.

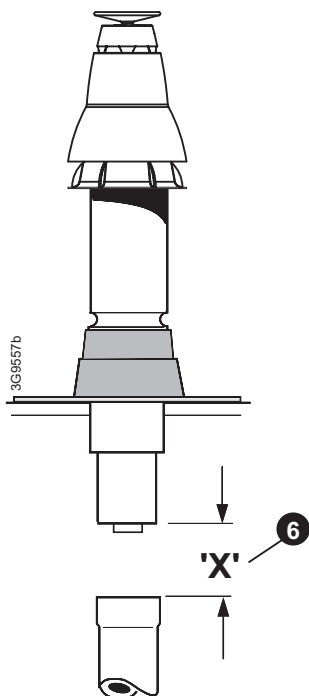
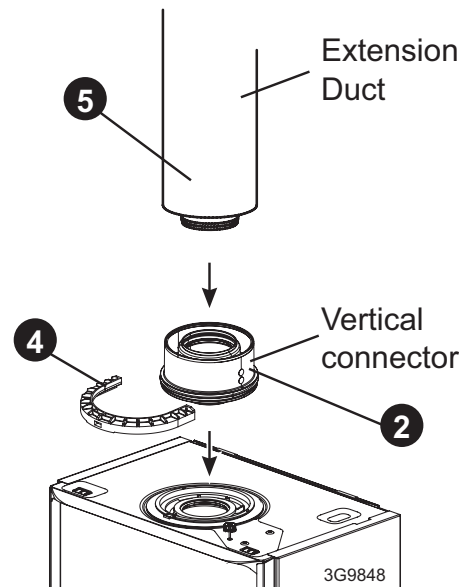

6. If the last extension duct requires cutting, measure 'X', the distance (outer ducts), between the duct and the terminal and add 100 mm to this dimension. This gives the length of the last extension duct.

**Note.** Check the position of the inner flue duct relative to the outer duct on the assembled extension duct(s) and ensure the terminal flue duct is cut longer than the air duct to ensure engagement in the final flue duct seal.

7. Finally ensure the roof flashing plate is correctly sealed to the roof.

## 28 CONNECTIONS & FILLING

### NOTES.

Ensure all boss blanking plugs are removed before connecting hardware. Each valve must be fitted to the correct boss as shown in the picture.

Ensure each union is fitted with fibre seals provided. Do not subject any of the isolating valves to heat as the seals may be damaged.

### WATER CONNECTIONS CH

1. Connect the CH flow service valve provided in the hardware pack to the threaded boss connection provided at the lower rear of the boiler.
2. Connect the CH return valve.
3. For boiler outputs of 18, 24 & 30:  
If connecting the boiler to heating loads in excess of 60,000 Btu/h, connecting flow and return heating systems pipework must be sized in 28mm diameter at the point of pipe connection to the boiler tails. Use 22mm x 28mm pipe adaptors as appropriate.

### GAS CONNECTION

**IMPORTANT.** The gas service cock is sealed with a non-metallic blue fibre washer, which must not be overheated when making capillary connections. Refer to Frame 1 for details of the position of the gas connection.

For additional gas supply information refer to "Gas Supply" on page 8.

### SAFETY VALVE DRAIN

The safety valve connection, located at the bottom right-hand side of the boiler, comprises a 15mm diameter stub pipe.

The discharge pipe should be positioned so that the discharge of water or steam cannot create a hazard to the occupants of the premises or damage the electrical components and wiring.

Note. An optional safety valve wall outlet kit is available if required.

### FILLING

#### IMPORTANT - when filling:

- A. Ensure the dust cap on air vent located at the rear of the pump chamber is slightly unscrewed.
- B. When filling, there may be a slight water leak from the air vent therefore electrical connections should be protected.

1. Ensure that the CH isolating handles are open.
2. Fill and vent the system. Refer to Frame 2 for filling and setting pressure procedure.
3. Check for water soundness.

Dust Cap

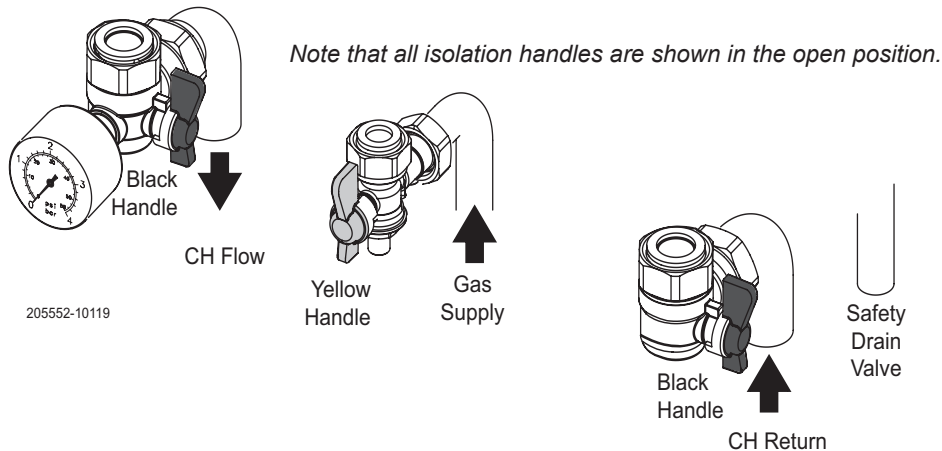

## 29 ELECTRICAL CONNECTIONS

**WARNING.** This appliance MUST be earthed.

A mains supply of 230Vac ~ 50 Hz is required.

The fuse rating should be 3A. All external controls and wiring must be suitable for mains voltage.

Wiring external to the boiler MUST be in accordance with the current I.E.E. (BS.7671) Wiring Regulations and any local regulations.

Wiring should be 3 core PVC insulated cable, not less than 0.75mm<sup>2</sup> (24 x 0.2mm), and to BS 6500 Table 16. For IE reference should be made to the current ETCI rules for electrical installations.

Connection must be made in a way that allows complete isolation of the electrical supply such as a double pole switch having a 3mm (1/8") contact separation in both poles. The means of isolation must be accessible to the user after installation.

## 30 INTERNAL WIRING

The Logic System boiler comes pre-fitted with 1.8m of mains cable. This must be connected to a permanent live supply and NOT switched by thermostats/programmers. For installers wishing to change this cable refer to Frame 31.

Connecting the Switched Live to the Boiler

1. Consult the Y Plan and S Plan diagrams below.
2. Isolate the mains supply to the boiler
3. Remove the front panel. Refer to Frame 7.
4. Swing the control box down into the servicing position.
5. Route incoming cable through a grommet in the bottom panel (note that the grommets are "blind" and will require puncturing) and secure using the clamp and screws provided in the hardware pack.
6. Connect the switched live to the terminal block as shown.

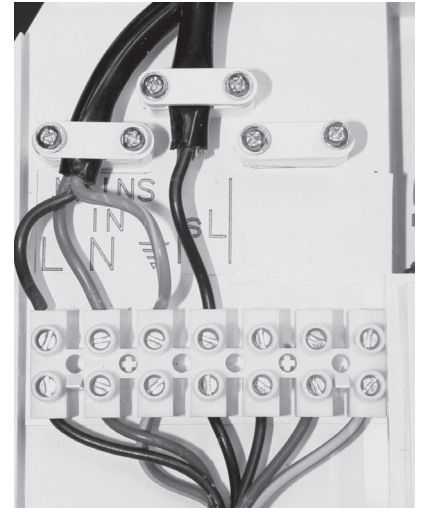

### FROST THERMOSTAT - WIRING

If parts of the system are vulnerable to freezing or the programmer is likely to be left off during cold weather, a frost stat should be fitted in conjunction with a pipe thermostat.

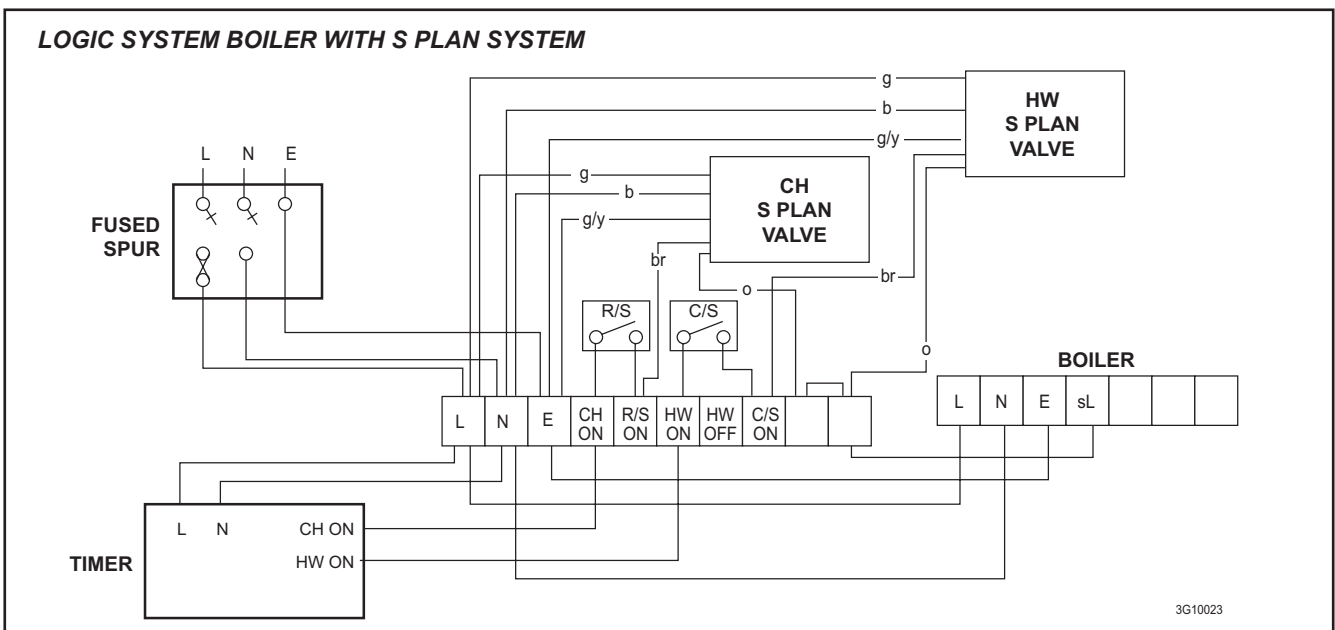
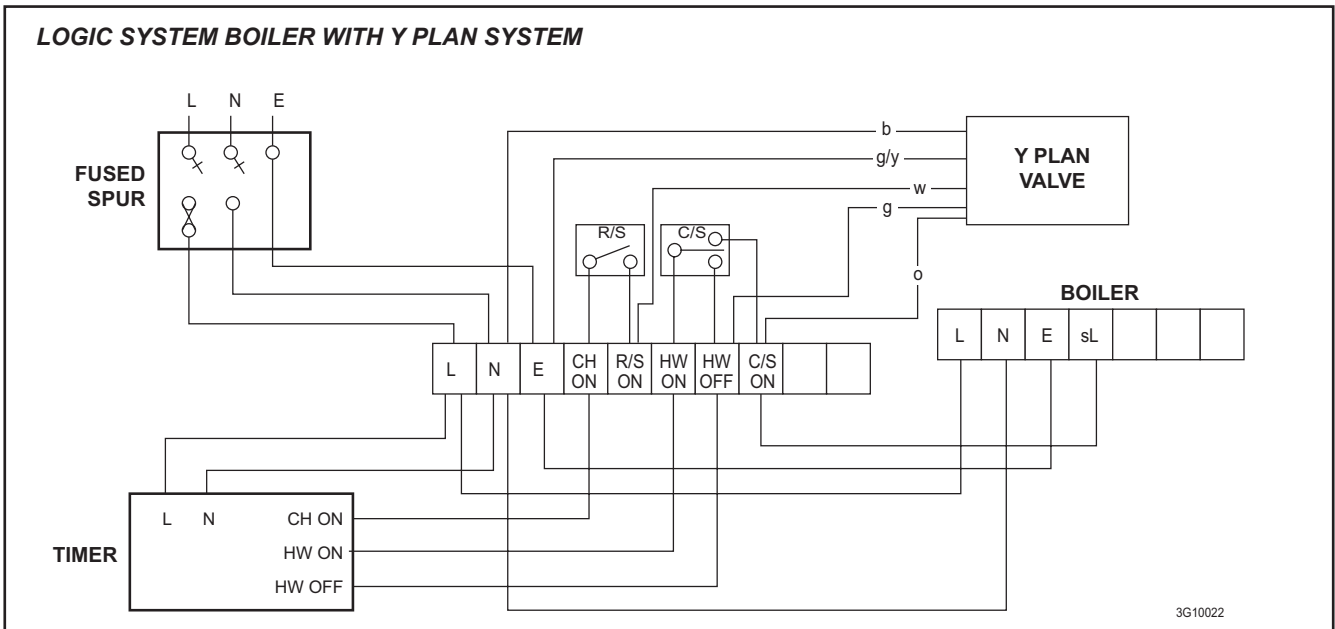

## INSTALLATION

### 31 REPLACING PRE-FITTED MAINS CABLE

If it is necessary to use an alternative mains cable to the one pre-fitted then use the following guide.

Replacement wiring should comply with notes in Frame 29.

1. Isolate the mains supply to the boiler.
2. Remove the front panel. Refer to Frame 40.
3. Swing the control box down into the service position. Refer to frame 46.
4. Remove the live, neutral and earth wires from the terminal block.
5. Loosen the cable clamp and withdraw the mains cable.
6. Route replacement cable back through the cable clamp and grommet and re-tighten to provide cord anchorage.
7. Connect the live, neutral and earth wires to the terminal strip. When making the mains electrical connections to the boiler it is important that the wires are prepared in such a way that the earth conductor is longer than the current carrying conductors, such that if the cord anchorage should slip, the current carrying conductors become taut before the earthing conductor.
8. Swing the control box back up into the operating position and re-fit the front panel ensuring a good seal is made.

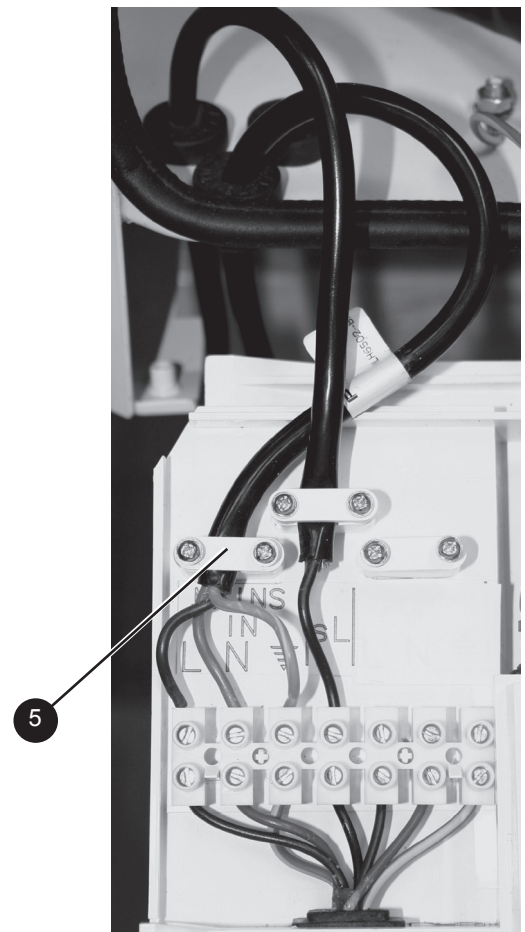

### 32 EXTERNAL ELECTRICAL CONTROLS

#### Wiring External to the Boiler

The fuse rating should be 3A.

Wiring external to the boiler MUST be in accordance with the current I.E.E. (BS.7671) Wiring Regulations and any local regulations.

#### Frost Protection

If parts of the pipework run outside the house or if the boiler will be left off for more than a day or so then a frost thermostat should be wired into the system.

The frost thermostat should be sited in a cold place but where it can sense heat from the system.

**Note.** *If the boiler is installed in a garage it may be necessary to fit a pipe thermostat, preferably on the return pipework.*

### 33 WIRING DIAGRAM

## INSTALLATION

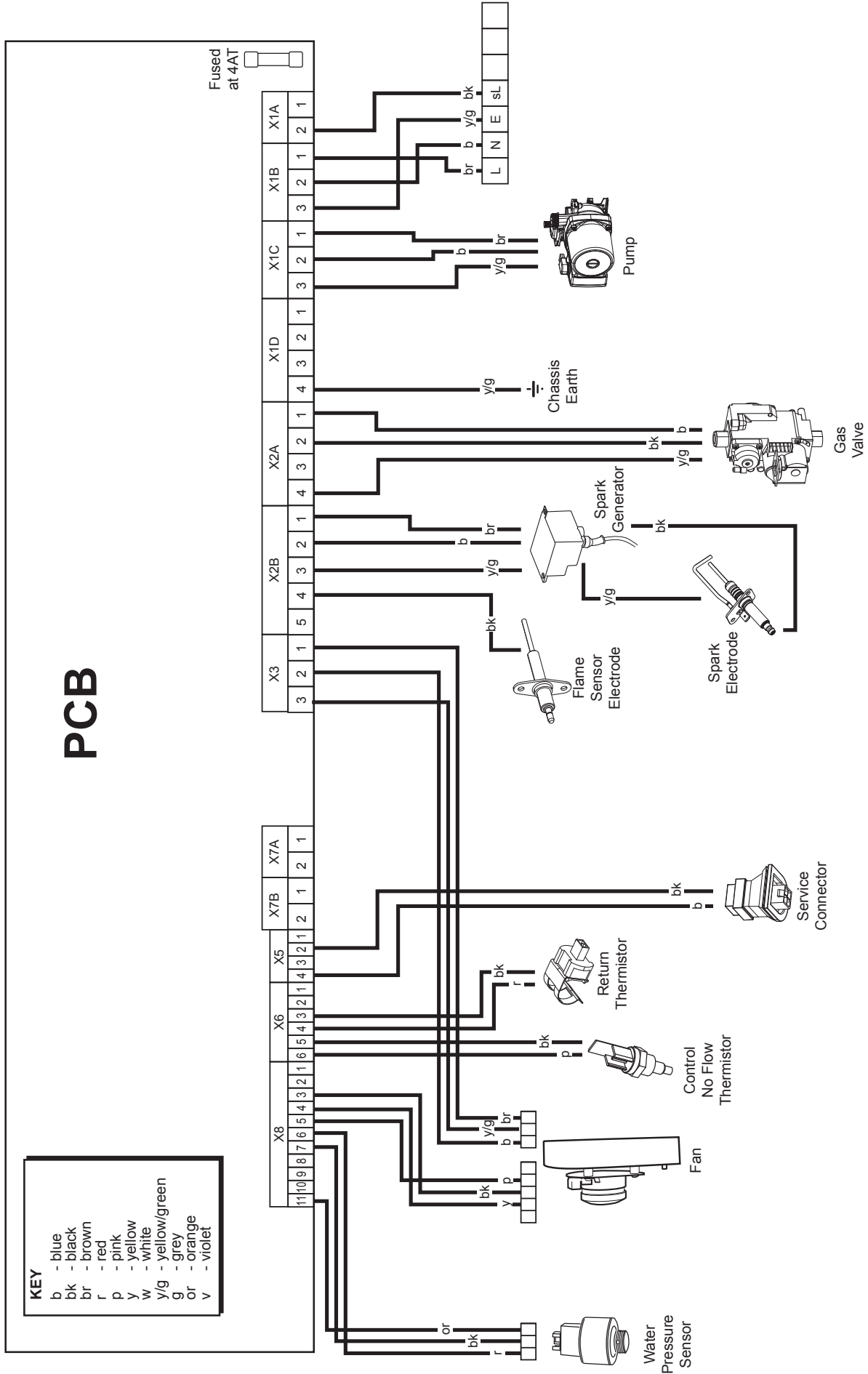

205552-9950b

## 34 COMMISSIONING AND TESTING

### A. Electrical Installation

1. Checks to ensure electrical safety should be carried out by a competent person.
2. ALWAYS carry out the preliminary electrical system checks, i.e. earth continuity, polarity, resistance to earth and short circuit, using a suitable test meter.

### B. Gas Installation

1. The whole of the gas installation, including the meter, should be inspected and tested for tightness and purged in accordance with the recommendations of BS. 6891. In IE refer to IS.813:2002.
2. Purge air from the gas installation by the approved methods only.

**WARNING.** Whilst effecting the required gas tightness test and purging air from the gas installation, open all windows and doors, extinguish naked lights and **DO NOT SMOKE.**

### GENERAL

**Please Note:** The combustion for this appliance has been checked, adjusted and preset at the factory for operation on the gas type defined on the appliance data plate. No measurement of the combustion is necessary. **DO NOT** adjust the air/gas ratio valve.

Having checked:

- That the boiler has been installed in accordance with these instructions.
- The integrity of the flue system and the flue seals, as described in the Flue Installation section.

Proceed to put the boiler into operation as follows:

### CHECK THE OPERATIONAL (WORKING) GAS INLET PRESSURE

Set up the boiler to operate at maximum rate.

With the boiler operating in the maximum rate condition check that the operational (working) gas pressure at the inlet gas pressure test point complies with the requirements - refer to "Gas Supply" on page 8.

Ensure that this inlet pressure can be obtained with all other gas appliances in the property working.

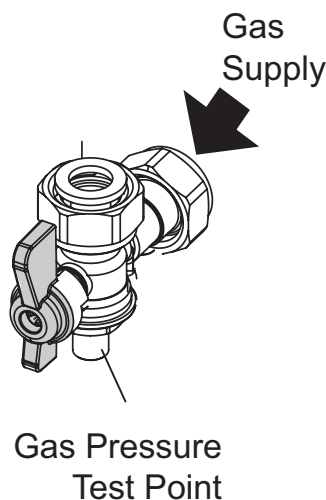

**ATTENTION !**  
IT IS A CONDITION OF THE MANUFACTURERS WARRANTY THAT THE BENCHMARK COMMISSIONING CHECKLIST IS FULLY COMPLETED AND LEFT WITH THE APPLIANCE

# INSTALLATION

## 35 INITIAL LIGHTING

### Legend

- A. CH temperature control
- B. Mode Control Knob
- C. Boiler Status
- D. Burner 'on' indicator
- E. CH Flow Isolating Valve
- F. Pressure Gauge
- G. Gas Inlet Pressure Test Point
- H. Gas Service Cock
- J. CH Return Isolating Valve
- K. Drain Valve

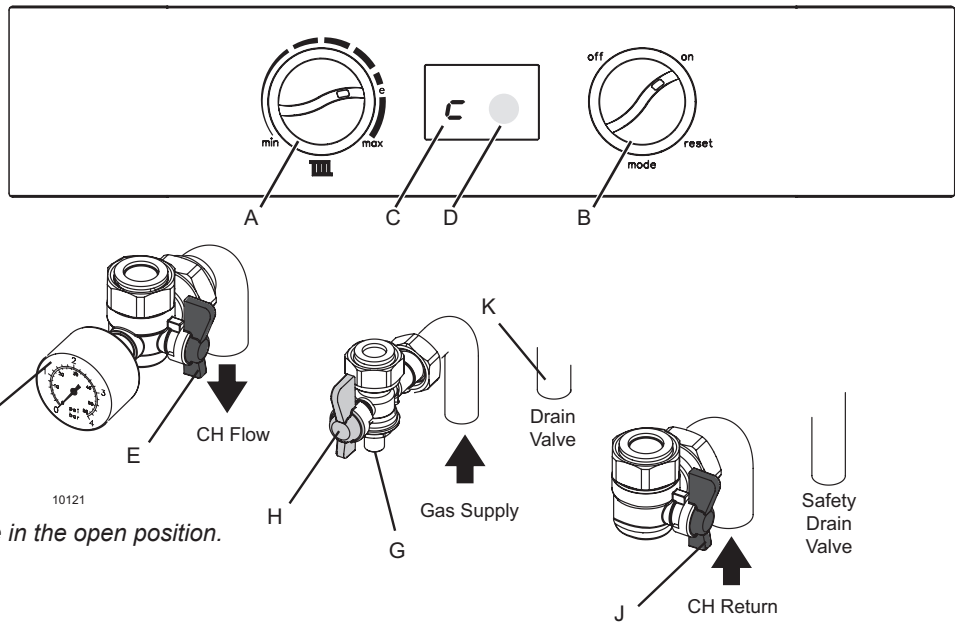

Note. Valves shown are in the open position.

1. Check that the system has been filled and that the boiler is not airlocked. Ensure the automatic air vent cap is open. Refer to Frame 28.

### Note.

It is important the burner is not operated before the system is fully vented of air. If it is necessary to operate the appliance pump to assist venting of the air this must be done with the gas service cock turned off.

2. Refit the boiler front panel. Refer to Frame 40.
3. Check that the drain valve (K) is closed and that the CH isolating valve (E and J) are OPEN.
4. Check that the electrical supply is OFF.
5. Check that the boiler mode control knob (B) is off.
6. Check that the gas service cock (H) is OPEN.
7. Slacken the screw in the inlet pressure test point (G) and connect a gas pressure gauge via a flexible tube.
8. Switch the electricity supply ON and check all external controls are calling for heat.

### CENTRAL HEATING

9. Set the CH temp control (A) to max and turn the mode control knob (B) to ON. The boiler control should now go through its ignition sequence until the burner is established.
10. If the boiler does not light after 5 attempts the boiler will lock out and display fault code  $L-2$  constantly. Reset the boiler (Refer to Frame 37). The boiler will repeat its ignition sequence. If reset occurs 5 times within 15 minutes then  $L-5$  will be shown. If power is removed this will be reset.

When the burner is established the BLUE 'Burner On' neon (D) will be illuminated, the LED display (C) will show status **C**.

11. Ensure that with the boiler operating the dynamic gas pressure is able to obtain maximum output. Refer to Table 2.

### IMPORTANT

The gas input to the burner is regulated by the gas valve according to the air flow produced by the fan. It is NOT user-adjustable. Any interference to sealed settings on the gas valve will adversely affect operation and render our warranty void.

For additional gas supply information refer to "Gas Supply" on page 8.

### THE DISPLAY

The user control has one neon and one display to inform the user about the status. The display will show the status of the boiler. The neon will show the status of the flame. If no flame is detected the neon is off. When the flame is detected the neon will be lit permanently.

Below is a list with display function in normal operation.

- $\emptyset$  Standby, no demand for heat present.
- $c$  Boiler is active for central heating or hot water.
- $F$  Boiler is active for boiler frost protection.
- $L$  Boiler is in lockout for a specific error. Display will be blinking, alternating with a number or letter to show which error is detected.
- $F$  Boiler has a fault for a specific error. Display will be blinking, alternating with a number or letter to show which error is detected.

**Note:** Boiler frost protection - boiler fires if temperature is below 5 degrees C.



*Note. The boiler incorporates a fan overrun cycle which MUST NOT be prematurely interrupted by isolation of the mains electricity supply.*



# INSTALLATION

## 36 GENERAL CHECKS Make the following checks for correct operation:

### CENTRAL HEATING (CH) MODE

1. Ensure that the CH external controls are calling for heat.  
The display should read: 
2. Check the boiler gas rate when the boiler is at full output.  
Check at the gas meter, with no other appliance in use. Refer to Table 2 for gas rate.
3. Set the central heating external controls to OFF. The burner should go off and the pump continue to run for 4 minutes  
The display should read: 
4. Check the correct operation of the timer and all other system controls. Operate each control separately and check that the main burner responds.

### WATER CIRCULATION SYSTEM

1. With the system COLD, check that the initial pressure is correct to the system design requirements.  
For pre-pressurised systems, this should be 1.0 bar.
2. With the system HOT, examine all water connections for soundness. The system pressure will increase with temperature rise but should not exceed 2.5 bar.
3. With the system still hot, turn off the gas, water and electricity supplies to the boiler and drain down to complete the flushing process.  
**Note:** A flushing solution should be used during the flushing procedure.  
Flushing solutions: Fernox Superfloc, Sentinel X300 (new systems) or X400 (existing systems). Refer to Frame 4.
4. Refill and vent the system, add inhibitor (see Frame 4), clear all air locks and again check for water soundness.
5. Reset the system initial pressure to the design requirement.
6. Balance the system. Refer to Frame 3.
7. Check the condensate drain for leaks and check that it is discharging correctly.
8. Finally, set the controls to the User's requirements.  
**Note:** The pump will operate briefly as a self-check once every 24 hours in the absence of any system demand.

### WATER TEMPERATURES

Temperatures can be selected using the CH temperature control (A)

Knob Setting	CH Flow Temp °C (°F)
Max	80 (176)
Min	30 (86)

## 37 RESET PROCEDURE

### Legend

- A. CH temperature control
- B. Mode Control Knob
- C. Boiler Status
- D. Burner 'on' indicator

To reset boiler, turn the mode control knob (B) to reset position and immediately turn knob back to required setting. The boiler will repeat the ignition sequence.

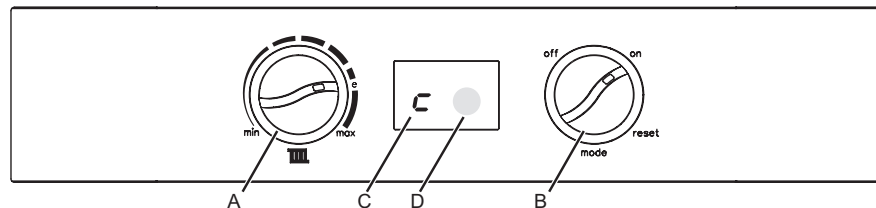

## 38 HANDING OVER

After completing installation and commissioning of the system the installer should hand over to the householder by the following actions:

1. Hand the User Instructions to the householder and explain his/her responsibilities under the relevant national regulations.
2. Explain and demonstrate lighting and shut down procedures.
3. The operation of the boiler and the use and adjustment of all system controls should be fully explained to the householder, to ensure the greatest possible fuel economy consistent with the household requirements of both heating and hot water consumption.  
Advise the User of the precautions necessary to prevent damage to the system and the building, in the event of the system remaining inoperative during frosty conditions.
4. Explain the function and the use of the boiler heating controls.
5. Explain the function of the boiler fault mode.  
Emphasise that if a fault is indicated refer to "Fault Codes" in the User Guide.
6. Explain and demonstrate the function of time and temperature controls, radiator valves etc., for economic use of the system.
7. If a timer is fitted draw attention to the timer Users Instructions and hand them to the householder.
8. Loss of system water pressure  
Explain that the dial underneath the boiler indicates the central heating system pressure and that if the normal COLD pressure of the system is seen to decrease over a period of time then a water leak is indicated. Explain the re-pressurising procedure and if unable to re-pressurise or if the pressure continues to drop a registered local heating installer should be consulted.
9. Explain Boiler reset procedure.
10. After installation and commissioning please complete the Benchmark Commissioning Checklist before handover to the customer. For IE, its is necessary to complete a "Declaration of Conformity" to indicate compliance to I.S. 813:2002.

### IMPORTANT

11. A comprehensive service should be carried out ANNUALLY.  
Stress the importance of regular servicing by a Gas Safe Registered Engineer. In IE servicing work must be carried out by a Registered Gas Installer (RGI).
12. Inform the householder of the guarantee/registration found within the envelope pack and the requirement to register it to receive the full benefit of the warranty.

## 39 SERVICING SCHEDULE

For the very latest copy of literature for specification & maintenance practices, visit our website [www.idealheating.com](http://www.idealheating.com), where you will be able to download the relevant information. N.B. Technical Bulletins are also available on [www.idealheating.com](http://www.idealheating.com).

**WARNING.** Always turn OFF the gas supply at the gas service cock, and switch OFF and disconnect the electricity supply to the appliance before servicing.

**Combustion testing must be carried out by a competent person using a combustion analyser conforming to BS7927.**

To ensure the continued safe and efficient operation of the appliance it is recommended that it is checked at regular intervals and serviced as necessary. The frequency of servicing will depend upon the installation condition and usage but should be carried out at least annually.

It is the law that any service work must be carried out by a Gas Safe Registered Engineer. In IE service work must be carried out by a Registered Gas Installer (RGII).

### INSPECTION

1. Light the boiler and carry out a pre-service check, noting any operational faults.
2. Check the flue terminal (and terminal guard if fitted) is undamaged and clear of any obstruction.
3. Check all water and gas joints for signs of leakage. Remake any suspect joints ensuring a gas tightness check is carried out if applicable and the water system is correctly refilled, vented and re-pressurised.

### CLEANING PROCEDURE

**Note.** In order to carry out either servicing or replacement of components the boiler front panel must be removed. Refer to Frame 40.

1. Clean the main burner. Refer to Frame 42.
2. Clean the heat exchanger & condensate trap/siphon. Refer to Frames 44 & 43.
3. Check the main injector for blockage or damage. Refer to Frame 41.
4. Check that the flue terminal is unobstructed and that the flue system is sealed correctly.

The cleaning procedures are covered more fully in Frames 41-45 and MUST be carried out in sequence.

### IMPORTANT.

6. After completing the servicing or exchange of components always test for gas tightness.
7. When work is complete the front panel MUST be correctly refitted, ensuring that a good seal is made.

**Do NOT OPERATE the boiler if the front panel is not fitted.**

8. If, for any reason, the condensate trap/siphon has been removed ensure the trap is refilled with water before reassembling.
9. Check the gas consumption.
10. Check combustion by connecting the flue gas analyser to the flue gas sampling point as shown in the diagram and measure CO & CO<sub>2</sub>.

If the CO/CO<sub>2</sub> ratio is greater than 0.004 AND the integrity of the complete flue system and combustion circuit seals have been verified and the inlet gas pressure (and gas rate) have been verified, then contact Ideal.

11. Complete the service section in the Benchmark Commissioning Checklist.

### GENERAL

**Please Note:** During routine servicing, and after any maintenance or change of part of the combustion circuit, the following must be checked:

- The integrity of the flue system and the flue seals,
- The integrity of the boiler combustion circuit and the relevant seals
- The operational (working) gas inlet pressure at maximum rate.
- The gas rate
- The combustion performance.

### COMPETENCE TO CARRY OUT THE CHECK OF COMBUSTION PERFORMANCE

**Please Note:** BS 6798:2009 Specification for installation and maintenance of gas-fired boilers of rated input not exceeding 70kW net advises that:

- The person carrying out a combustion measurement should have been assessed as competent in the use of a flue gas analyser and the interpretation of the results.
- The flue gas analyser used should be one meeting the requirements of BS7927 or BS-EN50379-3 and be calibrated in accordance with the analyser manufacturers requirements, and
- Competence can be demonstrated by satisfactory completion of the CPA1 ACS assessment, which covers the use of electronic portable combustion gas analysers in accordance with BS7967, Parts 1 to 4.

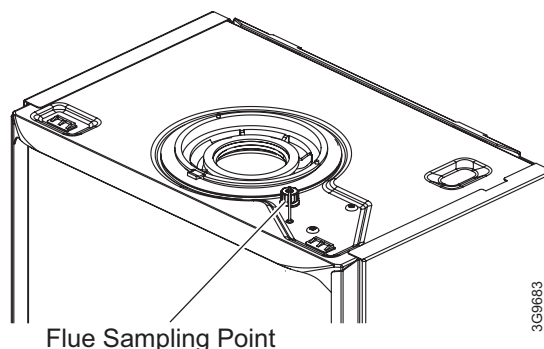

Flue Sampling Point

309683

## 40 BOILER FRONT PANEL REMOVAL / REPLACEMENT

### REMOVAL

1. Loosen the two screws retaining the front panel.
2. Pull the two spring clips down to disengage and pull panel forward and upward and remove.

### REPLACEMENT

3. Hook the panel onto the top retaining clips.
4. Push the panel until the 2 bottom spring clips engage ensuring the 4 control knobs line up with the holes in the front panel.
5. Re-tighten the two retaining screws.

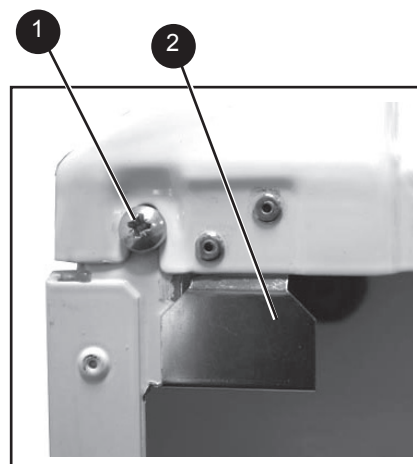

view from bottom of boiler

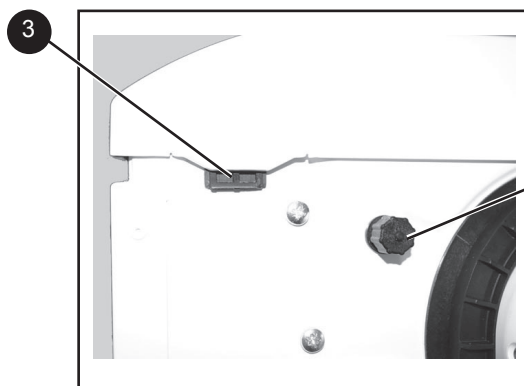

Flue sampling point

view from top of boiler

## 41 FAN AND VENTURI ASSEMBLY REMOVAL AND CLEANING

1. Disconnect the electrical leads from the fan.
2. Undo the gas pipe union connection to the injector housing.
3. Remove the extended nut on the fan mounting bracket.
4. Lift off fan and venturi assembly.
5. Inspect the injector for blockage or damage.
6. Inspect fan outlet sealing gasket and replace if necessary.

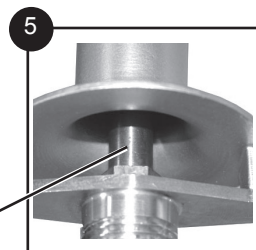
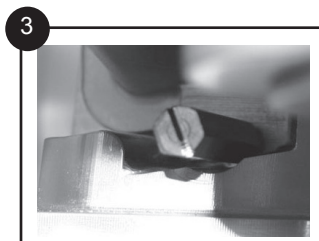

Injector

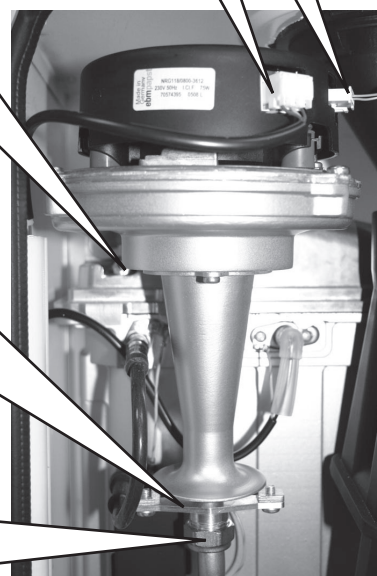
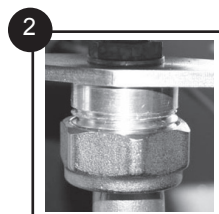

## 42 BURNER REMOVAL AND CLEANING

1. Ensure the sump is fully drained
2. Undo the two screws and remove the sump cover retaining the lower flue manifold.
3. Lift the manifold to clear the bottom sealing gasket and remove manifold.
4. Remove the 2 burner front fixing screws and loosen the 2 rear extended nuts by at least ten turns.
5. Lift off the burner from the combustion chamber. To facilitate the removal angle the burner as shown.

### IMPORTANT

The burner head is a ceramic plaque construction. Care must be taken to ensure that **the burner is not placed down upon its face** as this may cause damage to the ceramic.

6. Brush off any deposits that may be on the ceramic with a SOFT brush.
7. Inspect the sealing gasket around the burner for any signs of damage. Replace as necessary.

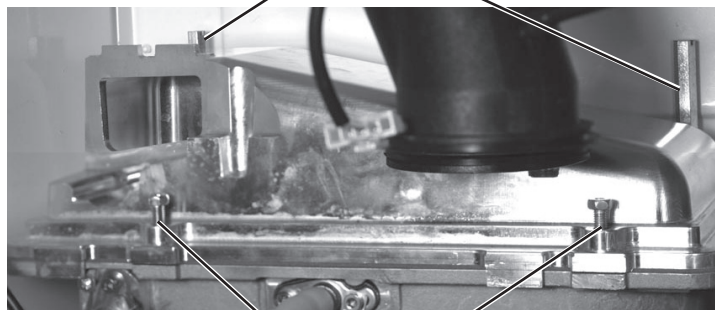
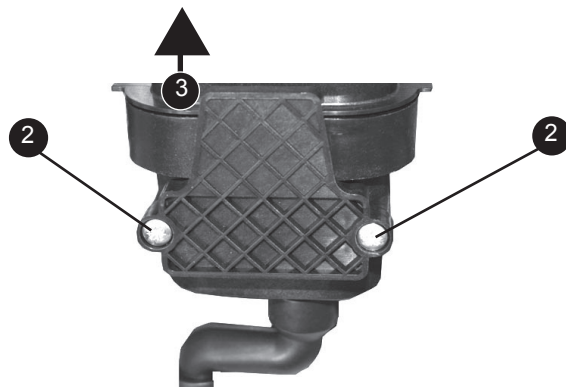

## 43 CLEANING THE CONDENSATE TRAP/SIPHON

1. Remove the cleaning plug taking care with any residual condensate.
2. Pull off the rubber pipe noting the position and flush out any deposits with clean water.
3. Replace the cleaning plug and refill the siphon with water.
4. Replace the rubber pipe connector with the twin wall seal fitted to the condensate siphon.

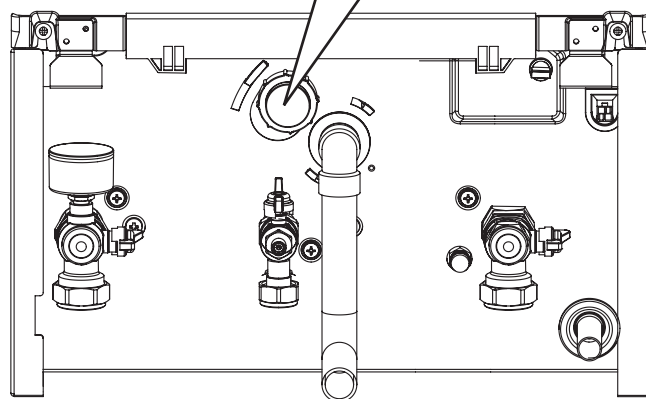
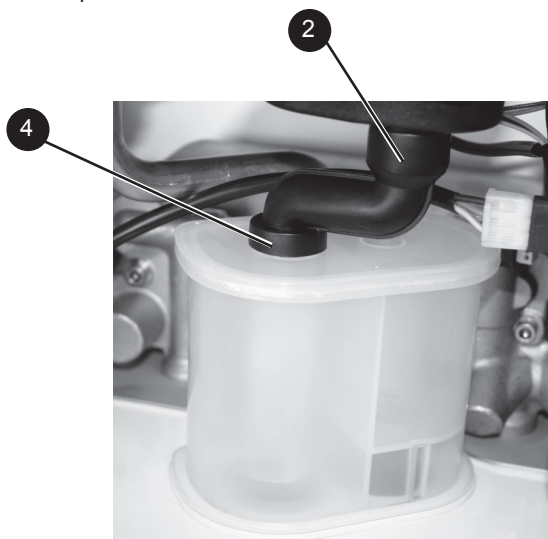
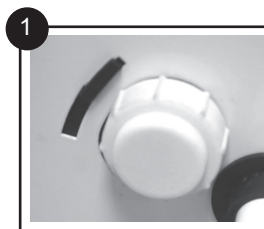

3G9953

## 44 CLEANING THE HEAT EXCHANGER

**Note:** Ensure the condensate trap/siphon is fully drained before cleaning. Refer to Frame 55.

1. Remove ignition and flame detection electrodes. Refer to Frames 51 & 52.
2. It is advisable to replace the sump cover prior to the water flush process.
3. Thoroughly flush the heat exchanger by pouring water into the top of the combustion chamber ensuring the full top area is covered.
4. Remove the sump cover and clean loose deposits from the sump.
5. Inspect the ignition and detection electrodes. Ensure that they are clean and in good condition - replace if necessary.
6. Re-fit the ignition and flame detection electrodes, ensuring that both earth tabs are fitted to ignition electrode.
7. Check that the ignition and detection gaps are correct. Refer to Frames 51 & 52.

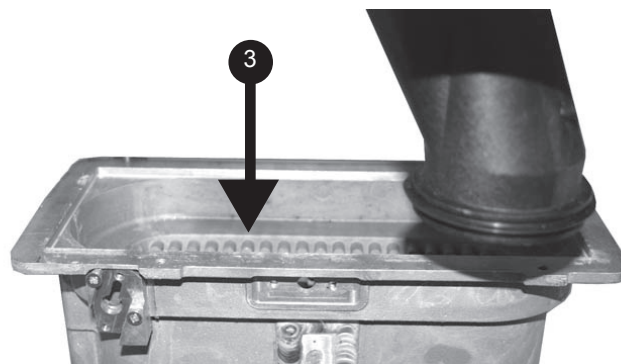
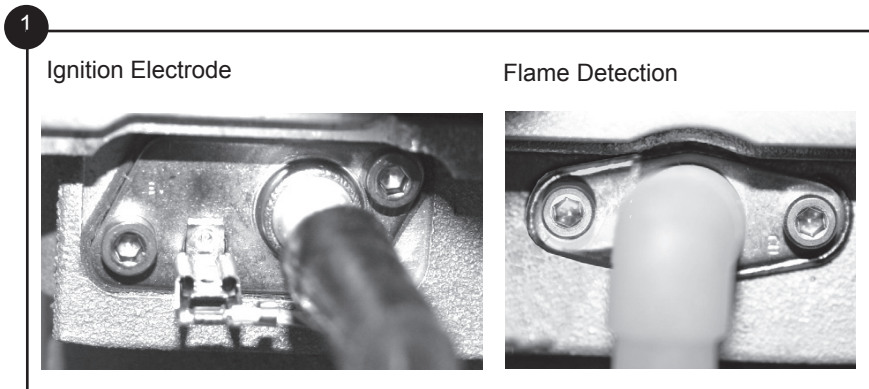

## 45 REASSEMBLY

Reassemble the boiler in the following order:

1. Ensure that the condensate trap/siphon is full of water.
2. Refit the burner ensuring the sealing gasket is correctly positioned and free from damage (tighten the 4 fixing screws in the sequence shown below).
3. Refit the fan / venturi assembly ensuring the retaining tabs are correctly positioned and the sealing gasket is correctly positioned and free from damage.
4. Reconnect the fan electrical leads.
5. Remove the sump cover and refit the lower flue manifold as shown.
6. Refit the sump cover.
7. Refit the boiler front panel.
 

**IMPORTANT.** Ensure that the boiler front panel is correctly fitted and that a good seal is made.
8. Swing the control box back into its working position and secure.
9. Turn on the gas supply at the gas service cock.
10. Reconnect the electrical supply.
11. Check the operation of the boiler. refer to Frame 35, 36 & 37

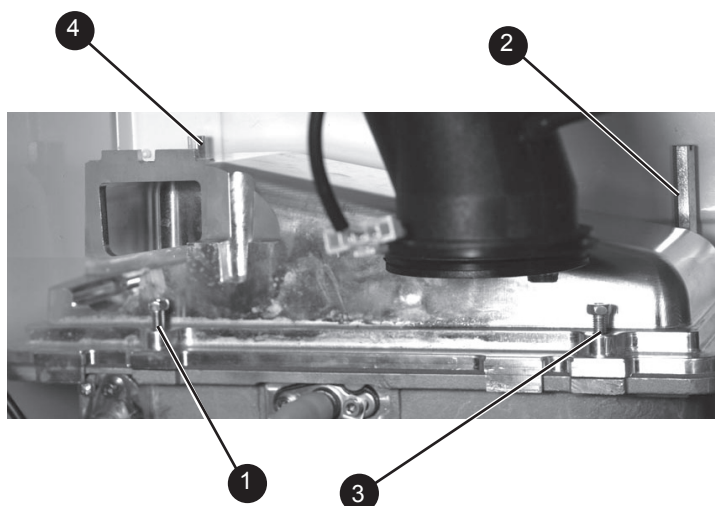

## 46 REPLACEMENT OF COMPONENTS

### GENERAL

#### When replacing ANY component

1. Isolate the electricity supply.
2. Turn off the gas supply.
3. Remove the boiler front panel. Refer to Frame 40.
4. Release the retaining clip and swing the control box down into its servicing position.

After replacing ANY component check operation of the boiler, including gas soundness, gas rate and combustion test.

#### IMPORTANT.

When work is complete, the front panel must be correctly refitted - ensuring that a good seal is made.

#### Notes.

1. In order to assist fault finding, the control panel has an LED diagnostic display. The key to boiler fault conditions is shown in Frame 68.
2. In order to replace components in Frames 59-66 it is necessary to drain the boiler. Refer to Frame 58.

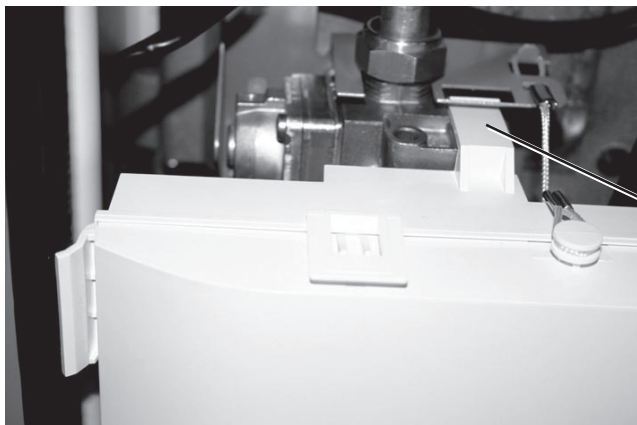

**THE BOILER MUST NOT BE OPERATED WITHOUT THE FRONT PANEL FITTED**

## 47 FAN REPLACEMENT

1. Refer to Frame 46.
2. Disconnect the electrical leads from the fan.
3. Undo the gas pipe union connection to the injector housing.
4. Remove the extended nut retaining the fan mounting bracket.
5. Lift and remove the fan and venturi assembly.
6. Remove the screw and twist venturi anti-clockwise to remove venturi assembly, *noting the orientation of the venturi in relation to the fan body.*
7. Transfer the venturi assembly to the new fan, replacing the 'o' ring if evidence of damage or deterioration is visible.
8. Fit the new fan / venturi assembly ensuring the retaining tabs are correctly positioned and the fan outlet sealing gasket is correctly positioned and free from damage. Refit the extended nut.
9. Reassemble the boiler in reverse order, taking care not to overtighten the screw on the fan mounting bracket.
10. Check the operation of the boiler. Refer to Frames 35, 36 & 37.

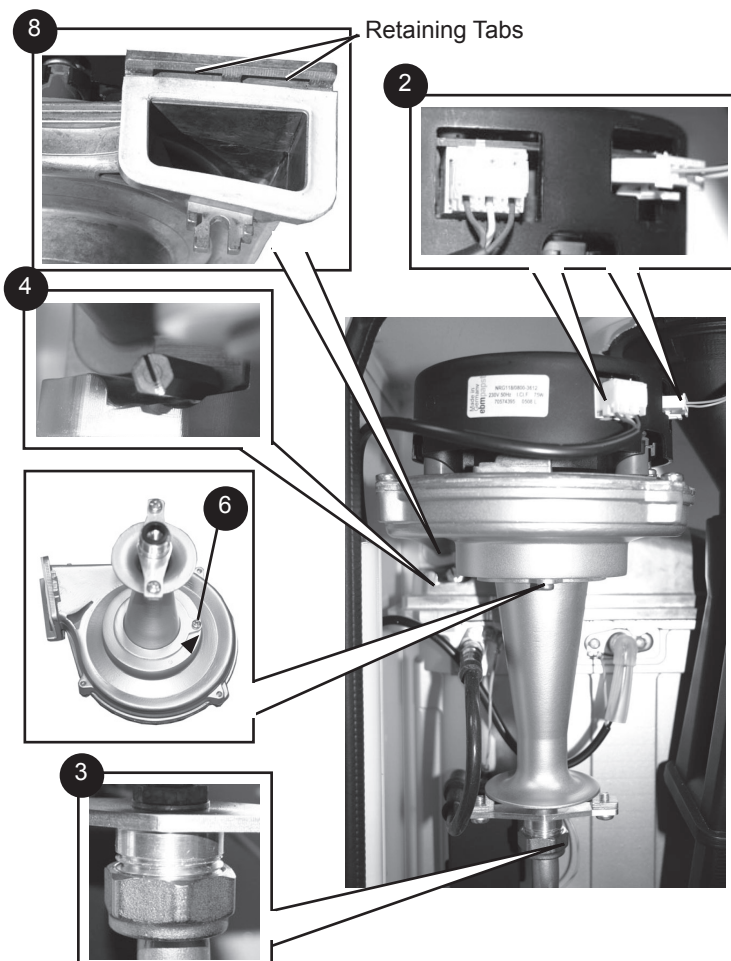

## 48 BURNER INJECTOR REPLACEMENT

1. Refer to Frame 46.
2. Disconnect the electrical leads from the fan.
3. Undo the gas pipe union connection to the injector housing.
4. Loosen the screw retaining the fan mounting bracket.
5. Lift and remove the fan and venturi assembly.
6. Remove the 2 injector housing screws.
7. Withdraw the injector housing.
8. Fit the new injector housing complete with injector.
9. Reassemble in reverse order, ensuring that the new gas seal supplied is located correctly in the injector housing.
10. Check operation of the boiler. Refer to Frames 35, 36 & 37.

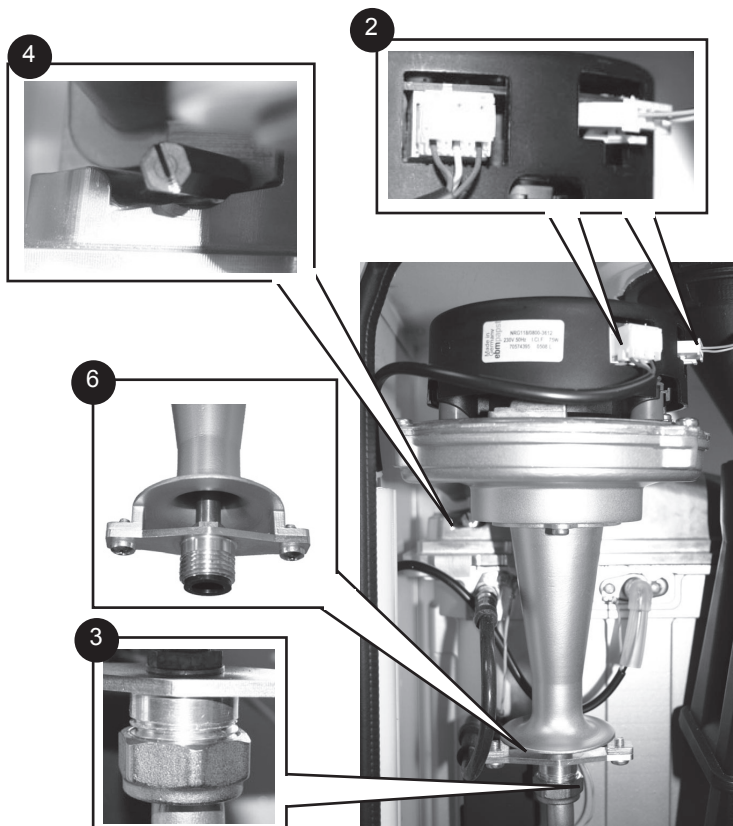

## 49 BURNER REPLACEMENT

1. See Frame 42.
2. Refer to Frame 46.
3. Undo the two screws and remove the sump cover.
4. Lift the manifold to clear the bottom sealing gasket and remove manifold.
5. Remove the 2 front fixing screws and loosen the 2 rear extended nuts.
6. Lift off the burner from the combustion chamber. To facilitate the removal angle the burner as shown.
7. Fit the new burner, replacing any damaged or deteriorating sealing gasket.
8. Reassemble in reverse order. Refer to Frame 45.
9. Check the operation of the boiler. Refer to Frames 35, 36 & 37.

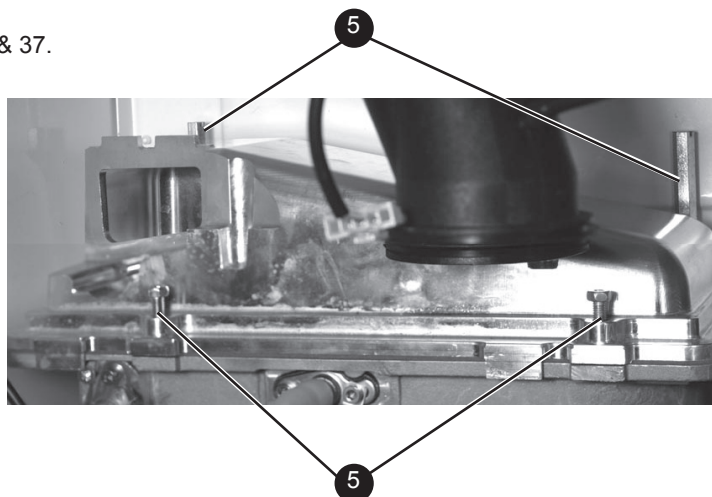
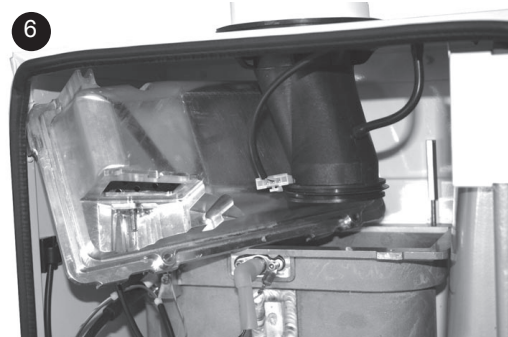
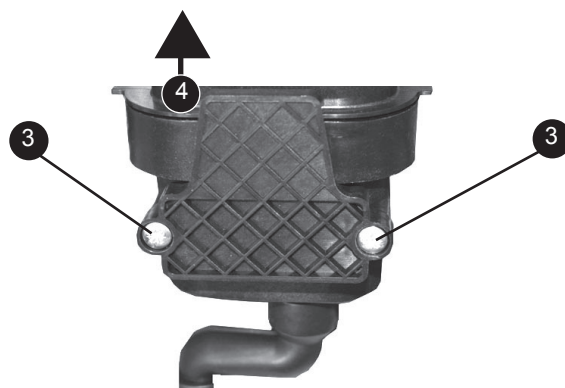

## 50 RETURN THERMISTOR RENEWAL

1. Refer to Frame 46.
2. Unclip the return thermistor from the return pipe and withdraw it from the boiler.
3. Disconnect the electrical leads from the thermistor.
4. Reconnect the electrical lead to the new thermistor and reassemble in reverse order, ensuring that the thermistor is securely fitted to the pipe on the thermistor locator tab as shown.
6. Check the operation of the boiler. Refer to Frames 35, 36 & 37.

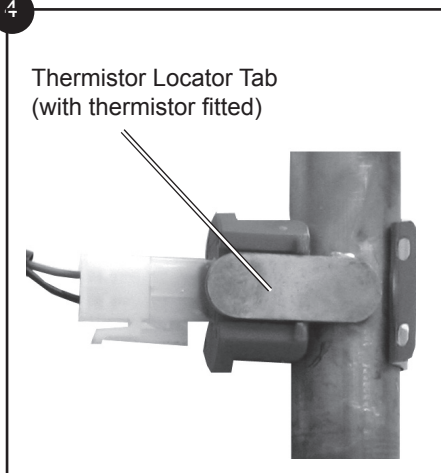

## 51 IGNITION ELECTRODE REPLACEMENT

1. Refer to Frame 46.
2. Remove the burner. Refer to Frame 49.
3. Unplug the ignition lead from the electrode.
4. Remove the earth lead from the ignition electrode.
5. Remove the 2 screws holding the ignition electrode to the combustion chamber.
6. Remove the electrode.
7. Fit the new ignition electrode, using the new gasket supplied. Check dimensions as shown.
8. Reassemble in reverse order.
9. Check the operation of the boiler. Refer to Frames 35, 36 & 37.

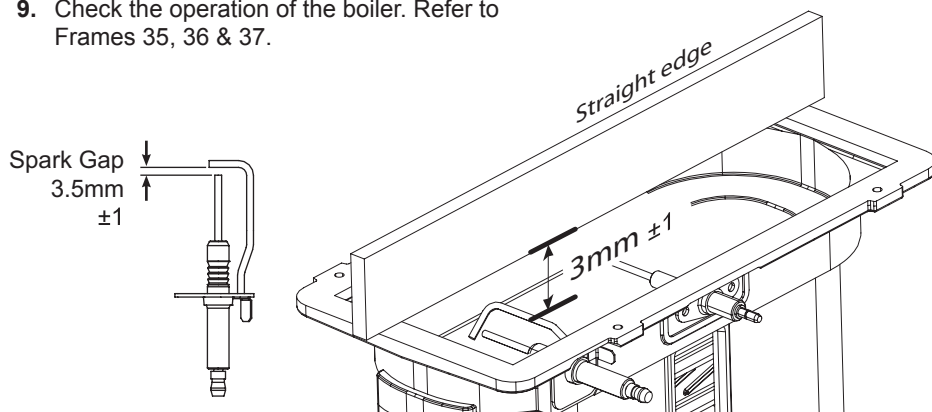
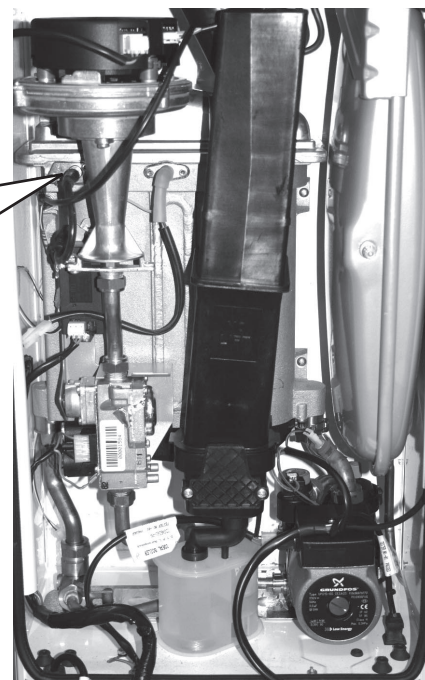
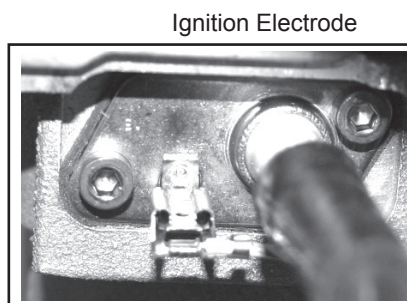



## 52 FLAME DETECTION ELECTRODE REPLACEMENT

1. Refer to Frame 46.
2. Remove the burner. Refer to Frame 49.
3. Unplug the flame detection lead from the electrode.
4. Remove the 2 screws retaining the detection electrode.
5. Remove the electrode.
6. Fit the new flame detection electrode, using the new gasket supplied.
7. Reassemble in reverse order.
8. Check the operation of the boiler. Refer to Frames 35, 36 & 37.

Flame Detection Electrode

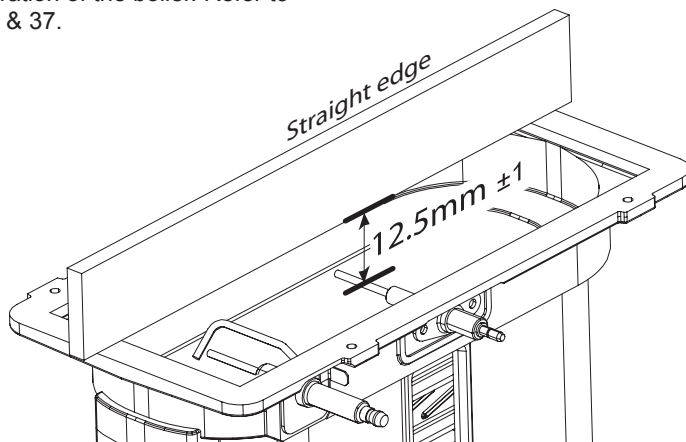
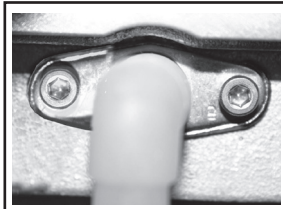

## 53 SPARK GENERATOR REPLACEMENT

1. Refer to Frame 46.
2. Disconnect the leads from the spark generator.
3. Remove the M5 screws securing the spark generator to the boiler chassis.
4. Fit the new spark generator and re-assemble in reverse order ensuring the two earth leads are correctly replaced.
5. Check operation of the boiler. Refer to Frames 35, 36 & 37.

Spark Generator

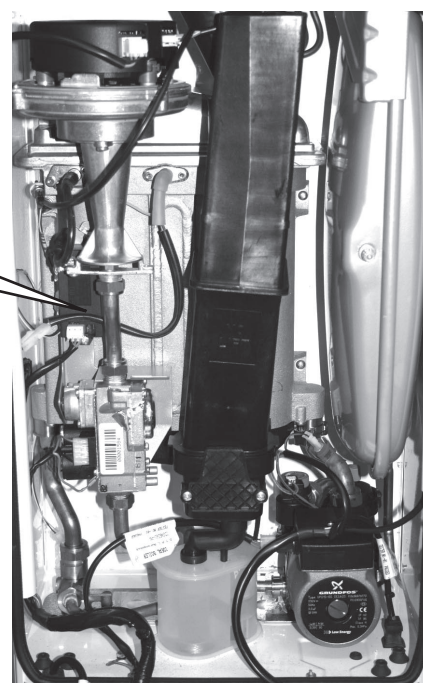
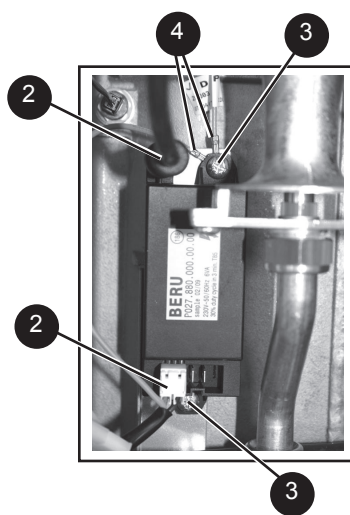

## 54 GAS CONTROL VALVE REPLACEMENT

1. Refer to Frame 46.
2. Unplug the electrical lead connection from the gas control valve and disconnect the earth wire.
3. Undo the union nut on the outlet of the gas control valve.
4. Undo the gas inlet pipe union at the inlet to the gas control valve.
5. Loosen the back nut retaining the valve to the bracket and withdraw the valve forwards.
6. Fit the new gas control valve ensuring the two sealing washers are in place and reconnect gas and electrical connections.
7. Check operation of the boiler. Refer to Frames 35, 36 & 37.

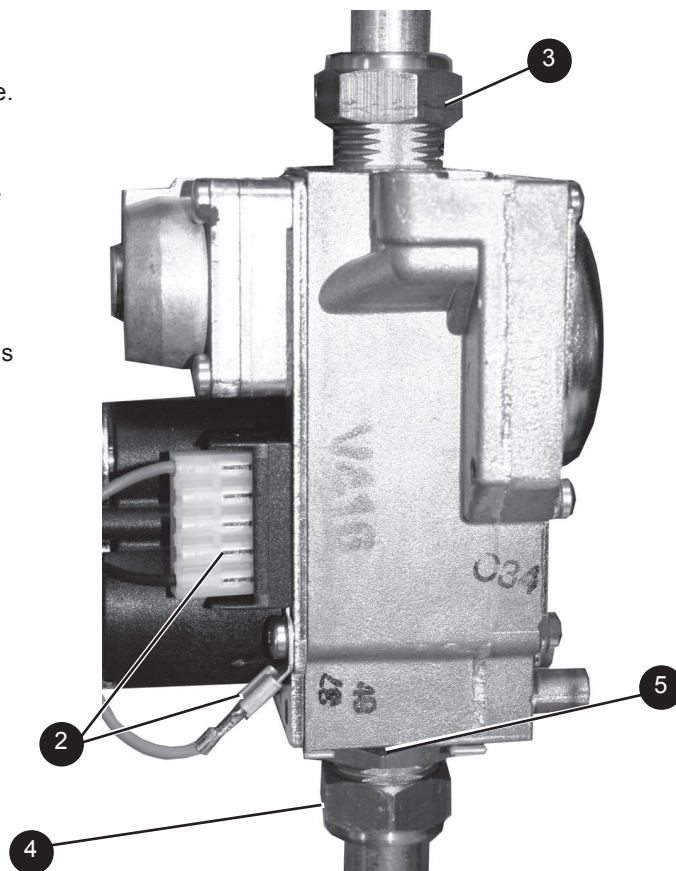

## 55 CONDENSATE TRAP/SIPHON REPLACEMENT

1. Refer to Frame 46.

**Note:** Ensure condensate trap is fully drained before removal.

2. Pull off the rubber pipe at the sump drain.
3. Disconnect the condensate drain pipe.
4. Remove the cleaning plug
5. Turn the siphon clockwise to disengage and lift to remove.
6. Reassemble in reverse order.
7. When reassembling ensure the trap is full of water.
8. Check operation of the boiler. Refer to Frames 35, 36 & 37.

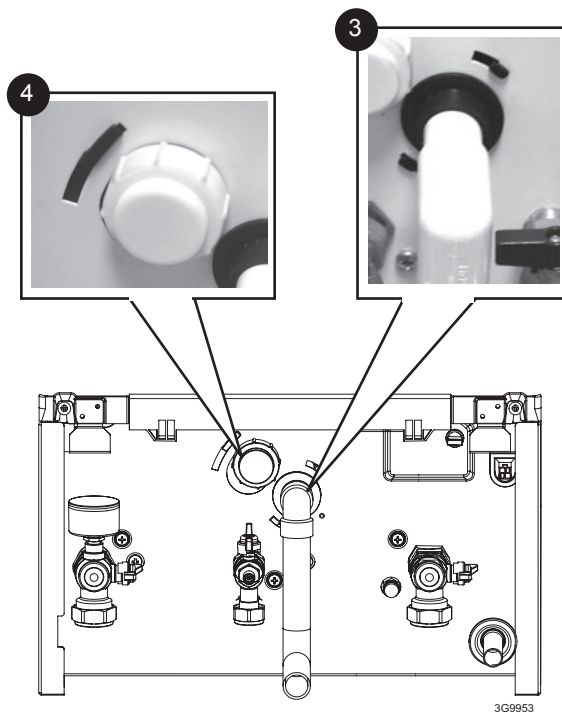
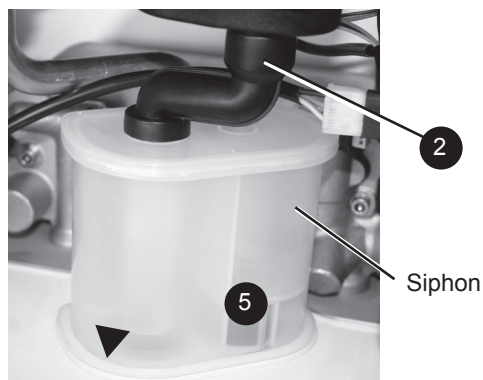

3G9953

## 56 MAIN PCB REPLACEMENT

Note that production boiler PCBs are factory pre-set to operate for boiler range and output, but when ordering Primary PCB as a spare, an additional Boiler Chip Card (BCC) MUST also be purchased for your specific boiler range and output.

**Note.** Fit the earth strap provided with the PCB to your wrist and secure to a suitable earth on the boiler chassis.

1. Refer to Frame 46.
2. Note the control knob positions.
3. Remove the 2 screws retaining the control box cover.
4. Carefully lift the 4 retaining clips and remove control box cover.
5. Unplug all lead connections to the PCB including the ribbon cable (to facilitate ribbon cable removal, ease side clips apart and pull upwards), also where applicable, push the small plastic clip with an electrical screwdriver to facilitate plug removal.
6. Spring out the two side retaining clips and pull the PCB upwards to clear the 4 corner retaining posts.
7. Take the new Primary PCB and attach the appropriate Boiler Chip Card (BCC) to it (this should correspond to the output of the boiler: 15kW, 18kW, 24kW or 30kW).  
**Note.** Ensure the correct orientation of BCC by placing "TOP" side up as shown.
8. Re-connect all plug connections.
9. Reassemble in reverse order.

10. Turn power back on to the boiler, after a few moments the display will start alternating between "F" and "0". Turn the reset knob fully clockwise and when the display shows "-" turn the knob fully anti-clockwise IMMEDIATELY.

Finally move the knob into the required position.

11. Check operation of the boiler. Refer to Frames 35, 36 & 37.

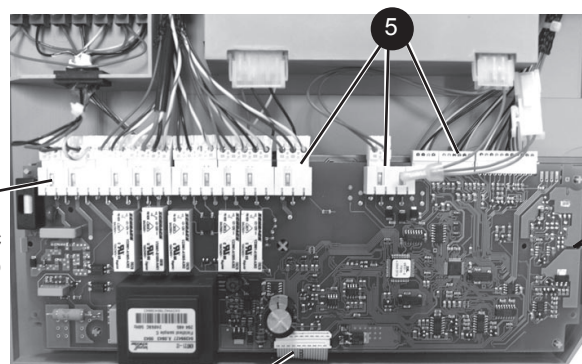
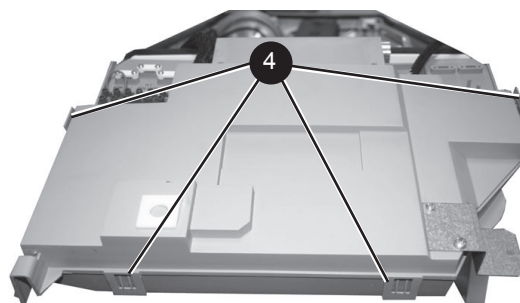
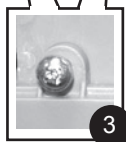
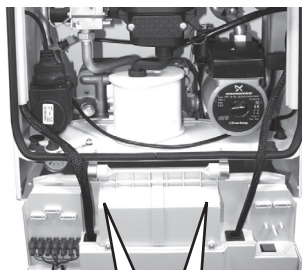

5  
Plastic Clip

Ribbon Cable Connection

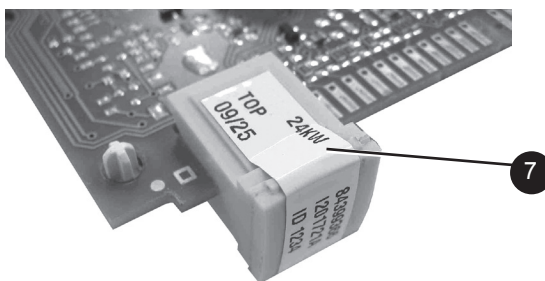
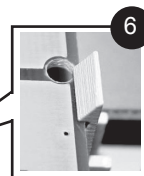

## 57 USER CONTROL PCB REPLACEMENT

**Note.** Fit the earth strap provided with the PCB to your wrist and a suitable earth on the boiler chassis.

1. Refer to Frame 46.
2. Remove the main PCB, refer to Frame 56.
3. Unclip the PCB and lift to clear the mounting posts.
4. Fit the new PCB ensuring the 4 potentiometer spindles line up with the control knobs which must be in a vertical position.
5. Reassemble in reverse order.
6. Check operation of the boiler. Refer to Frames 35, 36 & 37.

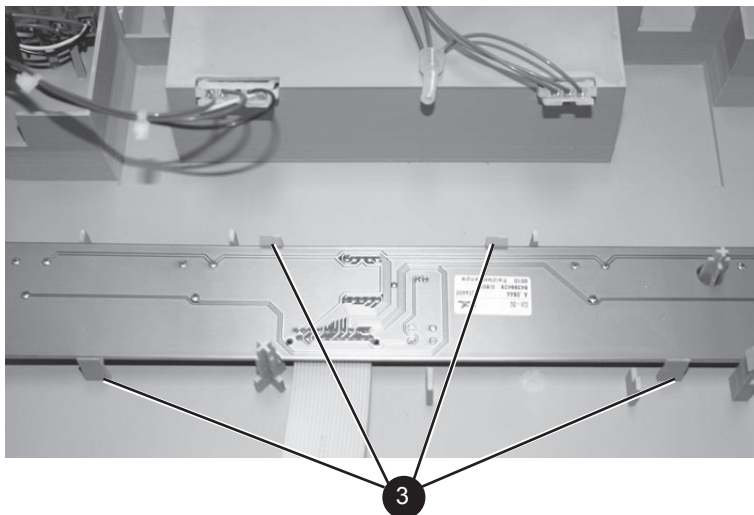

**4**

PCB

Potentiometer spindle

Control Knobs (to be in vertical position)

3G9954

## 58 DRAINING THE BOILER

### CENTRAL HEATING CIRCUIT

1. Refer to Frame 46.
2. Close all the CH water isolating valves on the boiler inlet.
3. To drain the primary heat exchanger circuit: Open the drain valve and attach a length of hose to the CH drain point.
4. After replacing any component on the boiler, remove the hose, close the drain valve and open all system isolating valves (re-pressurise as appropriate) before proceeding to check operation of the boiler.
5. Check operation of the boiler. Refer to Frames 35, 36 & 37.

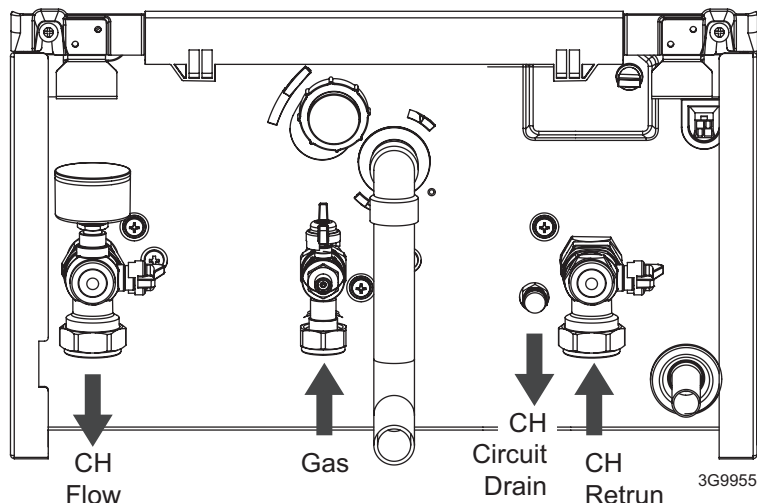

## 59 PRESSURE GAUGE RENEWAL

1. Refer to Frame 46.
2. Drain the heating system. Refer to Frame 58.
3. Unscrew the pressure gauge and discard.
4. Fit new pressure gauge, using suitable jointing compound.
5. Refill the boiler. Refer to Frame 28.
6. Check operation of the boiler. Refer to Frames 35, 36 & 37.

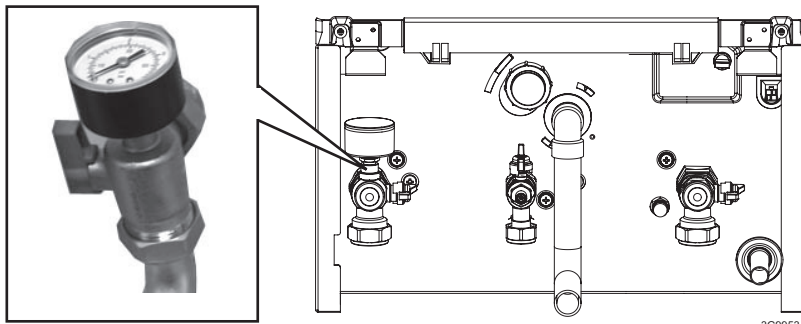

## 60 SAFETY RELIEF VALVE RENEWAL

1. Refer to Frame 46.
2. Drain the boiler. Refer to Frame 58.
3. Remove the condensate trap/siphon. Refer to Frame 55.
4. Remove expansion vessel. Refer to Frame 66.
5. Disconnect the electrical connection from the return thermistor.
6. Disconnect the 22mm pipe connection at the rear of the pump outlet.
7. Pull off the clip retaining the pipe to the heat exchanger swing the pipe to clear the pump and remove pipe.
8. Undo the safety valve union connection.
9. Withdraw the clip securing the safety valve.
10. Lift safety valve from boiler.
11. Fit the new safety valve and reassemble in reverse order ensuring the new 'o' ring is fitted to the top of the return pipe.
12. Refill boiler. Refer to Frame 28. Check operation of boiler. Refer to Frames 35, 36 & 37.

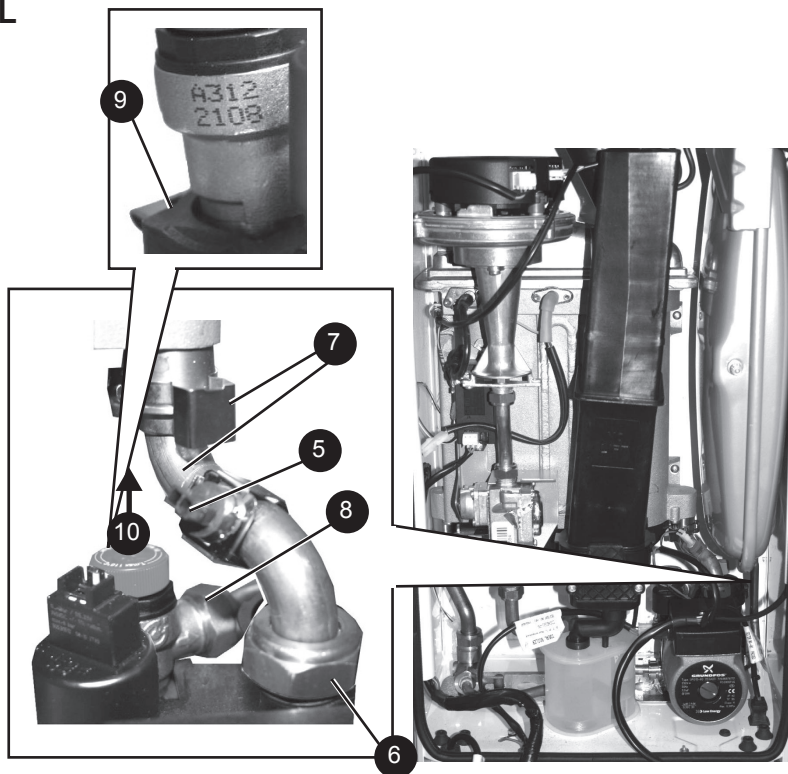

## 61 PUMP AUTOMATIC AIR VENT REPLACEMENT

1. Refer to Frame 46.
2. Drain the boiler. Refer to Frame 58.
3. Remove the expansion vessel. Refer to Frame 66.
4. Firstly, increase access area by disconnecting the 22mm pipe connection at top of pump chamber and bottom of heat exchanger and remove pipe Refer to Frame 60 (no's 5,6 & 7).
5. The automatic air vent head is retained in the pump body with a bayonet connection. The air vent head and float assembly is removed by turning the head anti-clockwise (viewed from above) and pulling upwards.
6. Reassembly is the reverse of the above. Ensure the air vent head 'o' ring seal is in place when refitting and the new 'o' ring is fitted to the return pipe top connection.
7. Ensure the air vent cap is loose.
8. Refill the boiler. Refer to Frame 28. Check for leaks around the new air vent joint.
9. Check the operation of the boiler. Refer to Frames 35, 36 & 37.

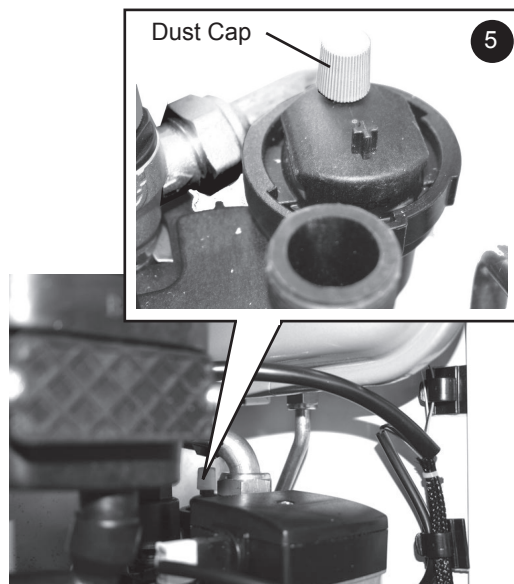

## 62 PUMP HEAD REPLACEMENT

1. Refer to Frame 46.
2. Drain the boiler. Refer to Frame 58.
3. Disconnect the electrical lead from the pump.
4. Remove the 4 Allen screws retaining the pump head.
5. Remove the pump head.
6. Fit the new pump head.
7. Reassemble in reverse order.
8. Refill the boiler. Refer to Frame 28.
9. Check operation of the boiler. Refer to Frames 35, 36 & 37.

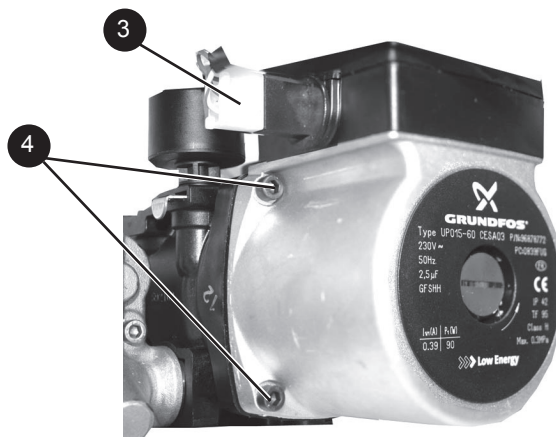

## 63 CH WATER PRESSURE SENSOR REPLACEMENT

1. Refer to Frame 46.
2. Drain the boiler. Refer to frame 58.
3. Remove condensate trap/siphon. Refer to Frame 55.
4. Using a suitable tool pull out the retaining clip.
5. Pull the pressure sensor upwards to remove.
6. Unplug the electrical connection and transfer to the new pressure sensor.
7. Push the new pressure sensor onto the rear pump housing and fit retaining clip.
8. Reassemble in reverse order.
9. Refill the boiler. Refer to Frame 28.
10. Check Operation of the boiler. Refer to Frames 35, 36 & 37.

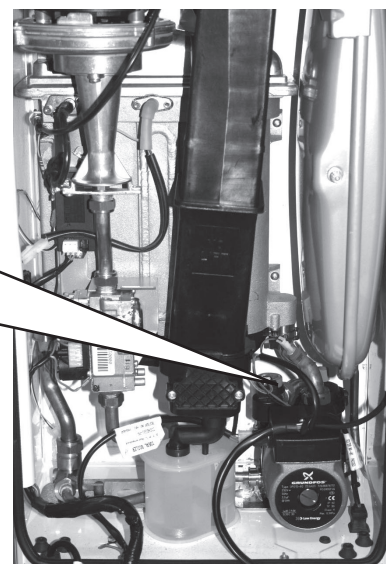
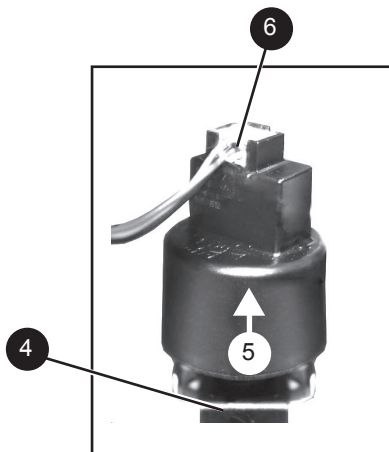

## 64 CONTROL / NO FLOW THERMISTOR REPLACEMENT

1. Refer to Frame 46.
2. Drain down the boiler. Refer to Frame 58.
3. Unplug the electrical lead.
4. Unscrew the thermistor (to facilitate removal a 13mm socket spanner should be used).
5. Fit the new thermistor using the sealing washer provided.
6. Reassemble in the reverse order.
7. Refill the boiler. Refer to Frame 28.
8. Check the operation of the boiler. Refer to Frames 35, 36 & 37.

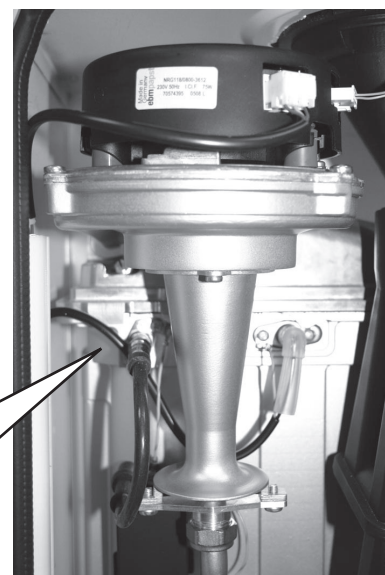
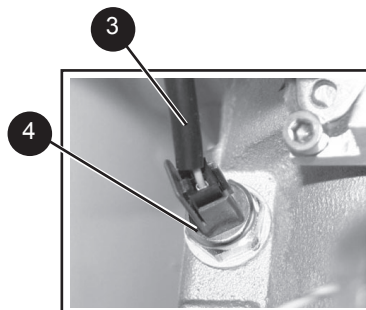

## 65 HEAT ENGINE RENEWAL

Refer also to Frame 5 - 'Boiler Exploded View'

### IMPORTANT

Before starting the removal procedure, protect the gas and electrical controls with a waterproof sheet or plastic bag.

1. Refer to Frame 46.
2. Drain the boiler. Refer to Frame 58.
3. Remove the fan / venturi assembly and place on one side. Refer to Frame 47.
4. Remove the burner and place on one side. Refer to Frame 49.
5. Remove the ignition and detection electrodes. Refer to Frames 51 & 52.
6. Remove the spark generator. Refer to Frame 53.
7. Remove the gas valve. Refer to Frame 54.
8. Remove the expansion vessel. Refer to Frame 66.
9. Remove the control/no flow thermistor. Refer to Frame 64.
10. Remove the 2 M5 screws retaining the gas valve mounting bracket and transfer bracket to the new heat exchanger.
11. Undo the inlet pipe union nut and remove the retaining spring clip and remove pipe.
12. Undo the flow pipe union nut and remove pipe.
13. Remove the condensate rubber pipe. Refer to Frame 55, no. 2.
14. Remove the two heat exchanger fixing screws.
15. Remove the Heat exchanger.
16. Reassemble in reverse order, ensuring the heat exchanger LH retaining bracket is correctly positioned. Replace any new 'o' rings supplied with new heat exchanger and replacing gaskets or seals if any sign of damage is evident. When replacing the spring clips located on both the flow and return pipe connections, ensure clip is oriented to correctly match connecting pipe diameters.
17. Ensure the trap/siphon is filled with water. Refer to Frame 55.
18. Refill the boiler. Refer to Frame 28.
19. Check operation of the boiler. Refer to Frames 35, 36 & 37.

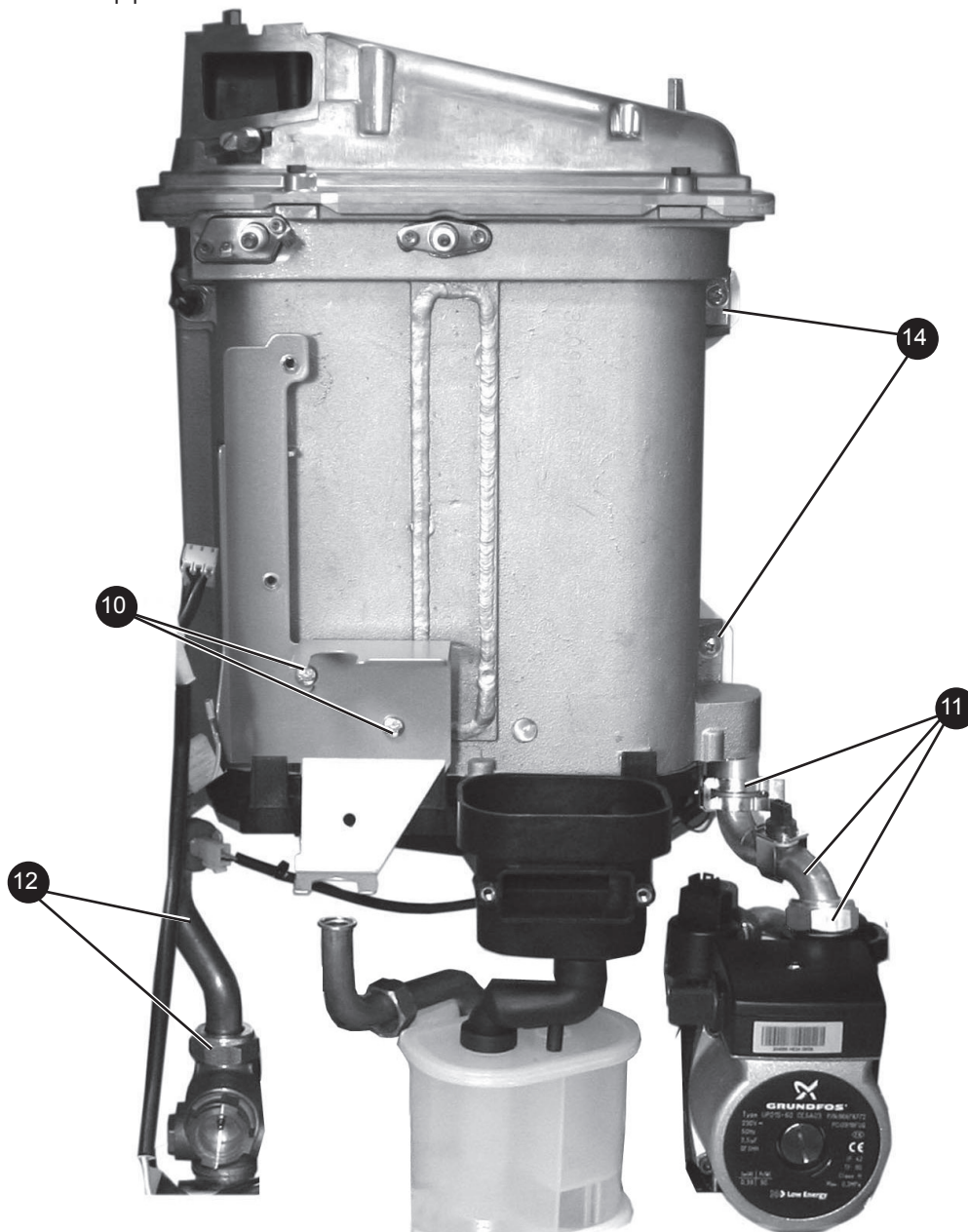

## 66 EXPANSION VESSEL RECHARGING & REPLACEMENT

### RECHARGING

1. Remove the charge point cover.
2. Recharge the tank pressure to 0.75 bar.
3. Re-assemble in reverse order
4. Check operation of the boiler. Refer to Frames 35, 36 & 37.

### REPLACEMENT

5. Refer to Frame 46.
6. Drain the boiler CH circuit. Refer to Frame 58.
7. Unscrew the union nut on the vessel water connection pipe.
8. Support the expansion vessel and unscrew the 2 screws from the securing clamp, located on the top of the boiler, and remove. (Note the position of the bracket on the vessel)
9. Remove the expansion vessel.
10. Fit the new expansion vessel.
11. Reassemble in reverse order.
12. Refill the boiler. Refer to Frame 28.
13. Check operation of the boiler. Refer to Frames 35, 36 & 37.

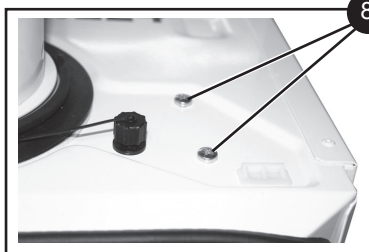
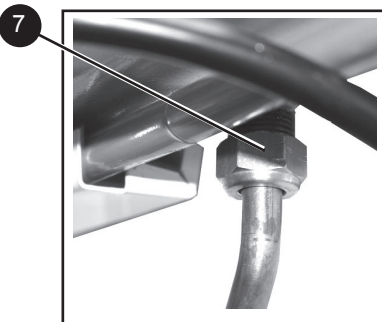

SERVICING

## 67 BOILER SEALING PANEL SEAL REPLACEMENT

1. Refer to Frame 46.
2. Remove the old seal from the casing and thoroughly clean the casing surfaces.
3. Fit the new seal, ensuring the bottom joint provides an air tight seal.
5. Reassemble in reverse order.
6. Check operation of the boiler. Refer to Frames 35, 36 & 37.

**Note.** *Ensure that the boiler front panel is correctly sealed, compressing the seal to make an airtight joint.*

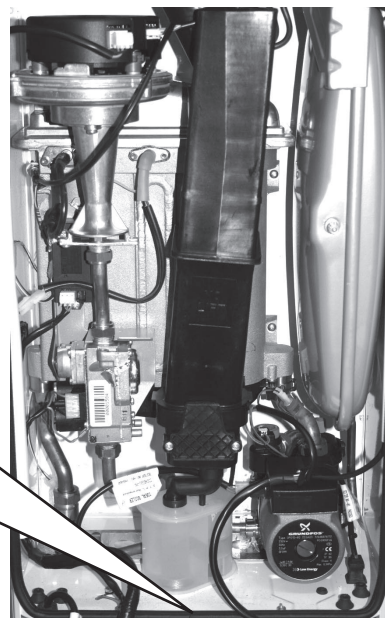
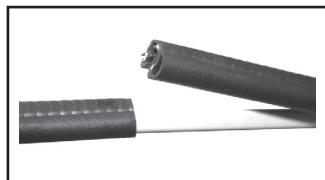



## FAULT FINDING

### 68 FAULT FINDING CHART MAIN MENU

In order to assist fault finding the boiler has a 7 segment display. The key to the display codes is as follows:

ALTERNATING 'L' and '1'	GO TO FRAME 69 - FLOW TEMPERATURE OVERHEAT LOCKOUT or NO WATER FLOW LOCKOUT
ALTERNATING 'L' and '2'	GO TO FRAME 70 - IGNITION LOCKOUT
ALTERNATING 'L' and '5'	5 RESETS WITHIN 15 MINS - TURN POWER OFF AND ON
ALTERNATING 'L' and '6'	GO TO FRAME 71 - FALSE FLAME LOCKOUT
ALTERNATING 'F' and '0'	BCC (BOILER CHIP CARD) NOT FITTED SEE FRAME 56
ALTERNATING 'F' and '1'	GO TO FRAME 72 - LOW WATER PRESSURE
ALTERNATING 'F' and '2'	GO TO FRAME 73 - FLAME LOSS
ALTERNATING 'F' and '3'	GO TO FRAME 74 - FAN FAULT
ALTERNATING 'F' and '4'	GO TO FRAME 75 - CONTROL/NO FLOW THERMISTOR FAULT
ALTERNATING 'F' and '5'	GO TO FRAME 76 - RETURN THERMISTOR FAULT
ALTERNATING 'F' and '6'	GO TO FRAME 77 - OUTSIDE SENSOR FAULT
ALTERNATING 'F' and '7'	LOW MAINS VOLTAGE - CONTACT ELECTRICITY PROVIDER
ALTERNATING 'F' and '9'	PCB FAULT - **REPLACE PCB
ALTERNATING 'c' and '2'	GO TO FRAME 78 - BCC FAULT (BOILER CHIP CARD)
ALTERNATING 'c' and '0'	RESET BOILER
NO CH	GO TO FRAME 79
NO HW	GO TO FRAME 81
NO DISPLAY	GO TO FRAME 80

Note that production boiler PCBs are factory pre-set to operate for boiler range and output, but when ordering Primary PCB as a spare, an additional Boiler Chip Card (BCC) MUST also be purchased for your specific boiler range and output.

\*\*If PCB replaced as a spare ensure that the BCC (boiler chip card - small plastic part) is fitted to the PCB otherwise replace PCB.

**RESET PROCEDURE** - To reset boiler, turn mode knob to reset position and immediately turn knob back to required setting.

## FAULT FINDING

### 69 ALTERNATING 'L' AND '1' - FLOW TEMPERATURE OVERHEAT LOCKOUT OR NO WATER FLOW LOCKOUT

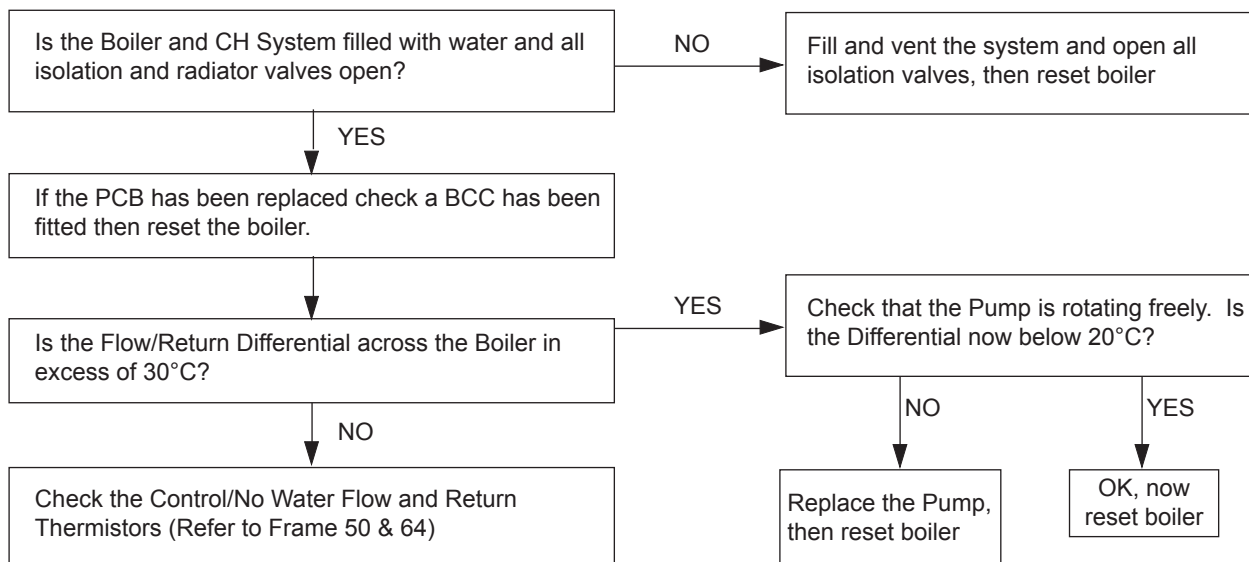

**RESET PROCEDURE** - To reset boiler, turn mode knob to reset position and immediately turn knob back to required setting.

### 70 ALTERNATING 'L' AND '2' - IGNITION LOCKOUT

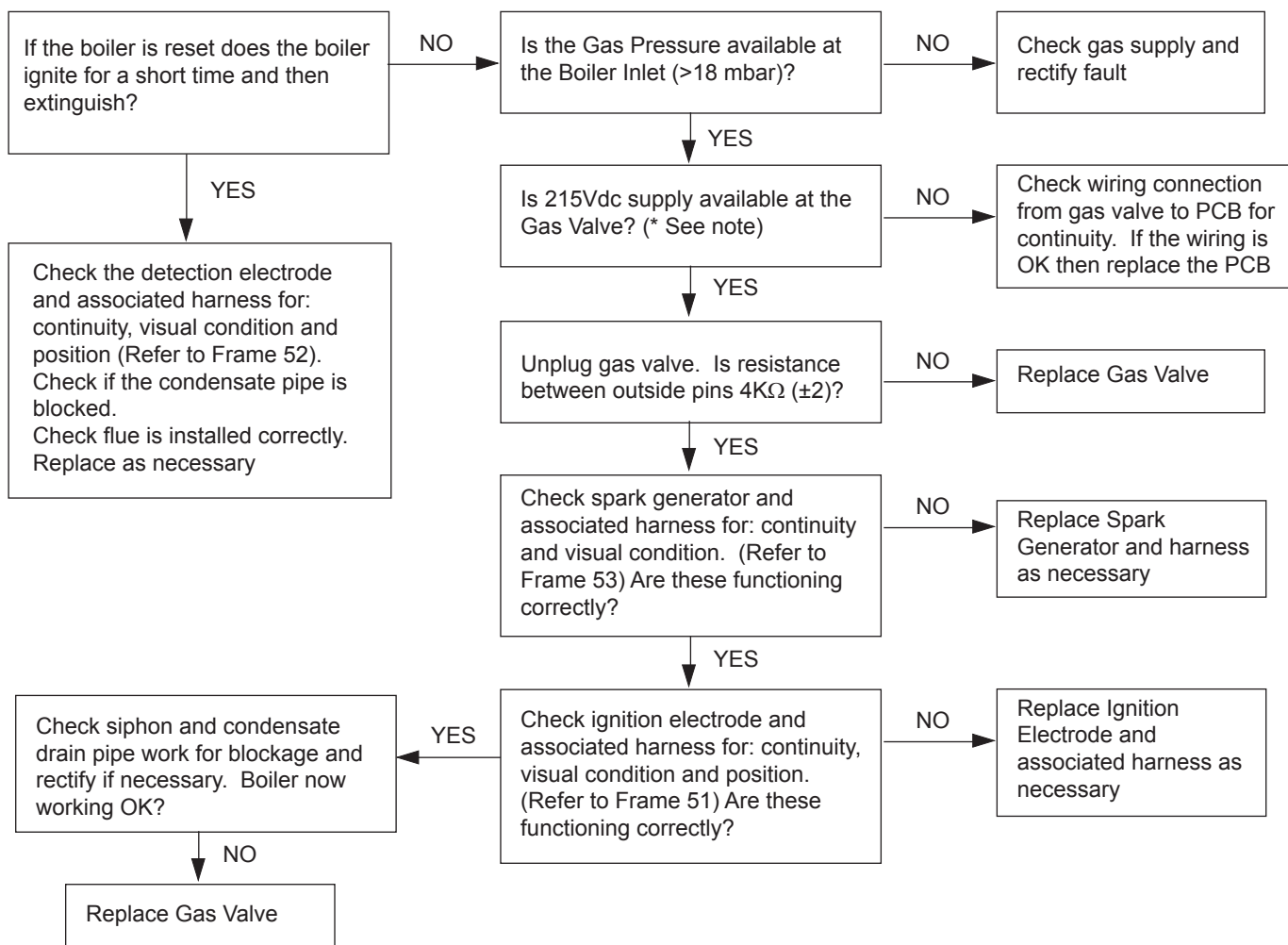

\* **Note:** due to the wave form of the rectified voltage, the reading will vary depending on the type of meter used to measure the value. In general terms a reading greater than 150V indicates that the correct voltage is supplied to the gas valve.

**RESET PROCEDURE** - To reset boiler, turn mode knob to reset position and immediately turn knob back to required setting.

## FAULT FINDING

### 71 ALTERNATING 'L' AND '6' - FALSE FLAME LOCKOUT

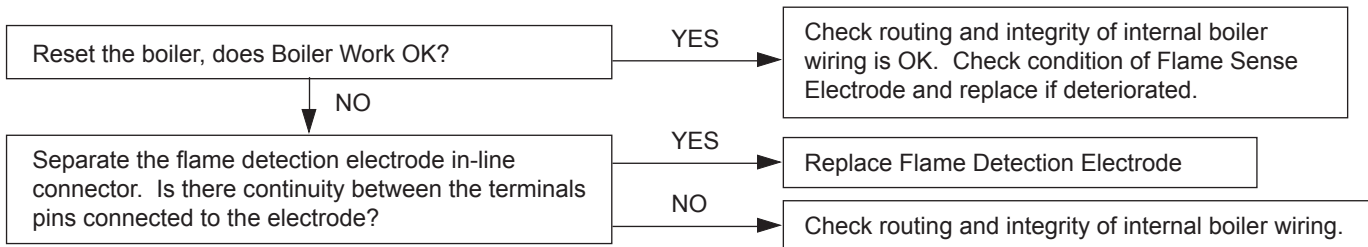

**RESET PROCEDURE** - To reset boiler, turn mode knob to reset position and immediately turn knob back to required setting.

### 72 ALTERNATING 'F' AND '1' - LOW WATER PRESSURE

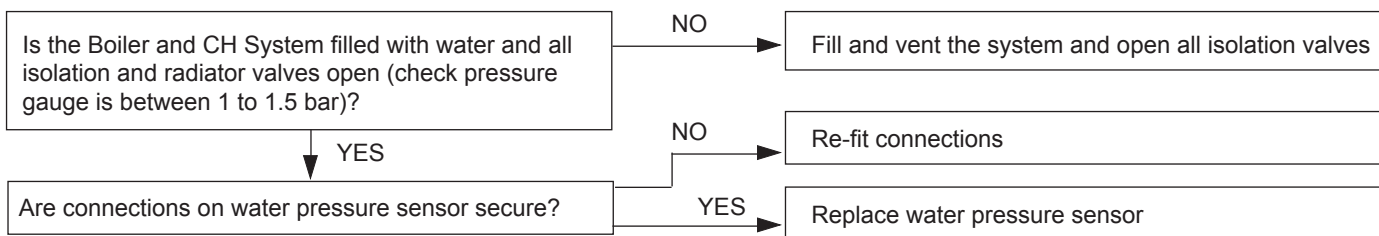

### 73 ALTERNATING 'F' AND '2' - FLAME LOSS

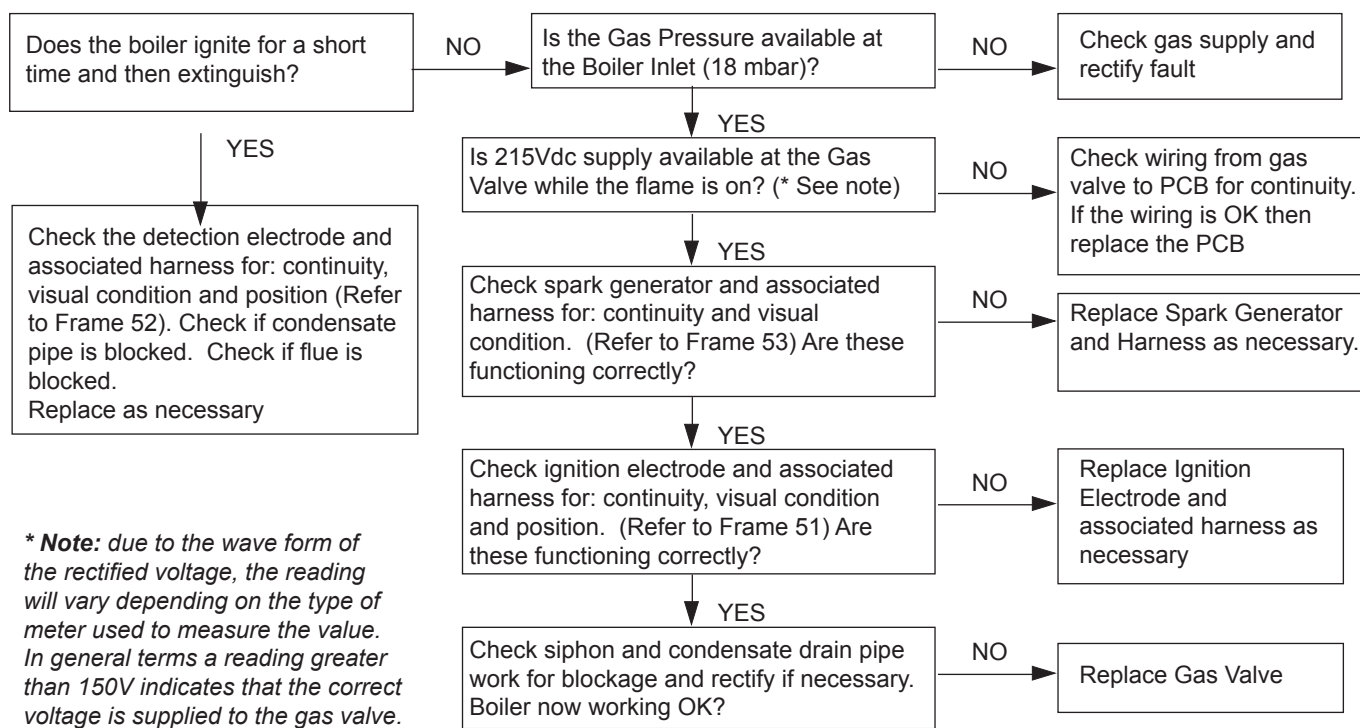

### 74 ALTERNATING 'F' AND '3' - FAN FAULT

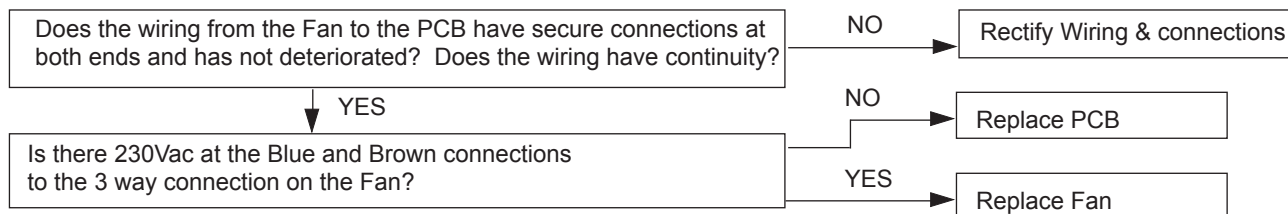

## FAULT FINDING

### 75 ALTERNATING 'F' AND '4' - CONTROL / NO FLOW THERMISTOR FAULT

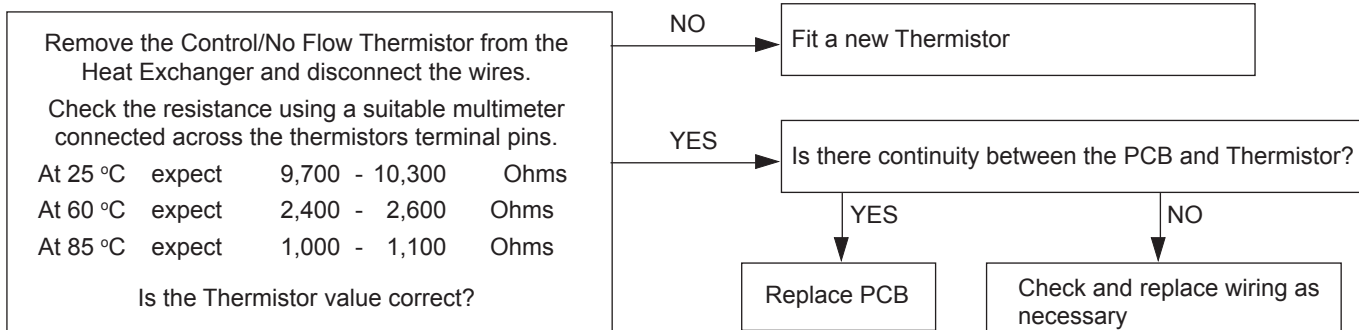

### 76 ALTERNATING 'F' AND '5' - RETURN THERMISTOR FAULT

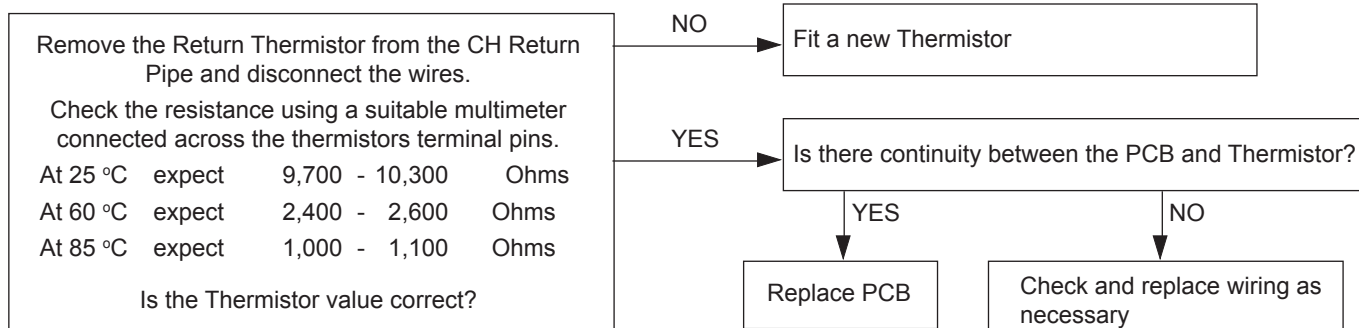

### 77 ALTERNATING 'F' AND '6' - OUTSIDE SENSOR FAULT

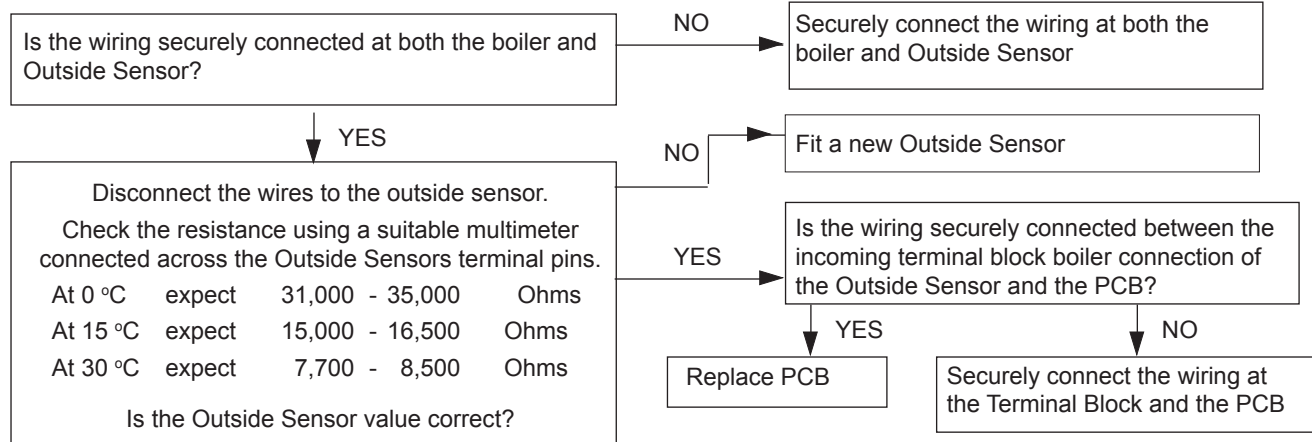

### 78 ALTERNATING 'c' AND '2' - BCC FAULT (BOILER CHIP CARD)

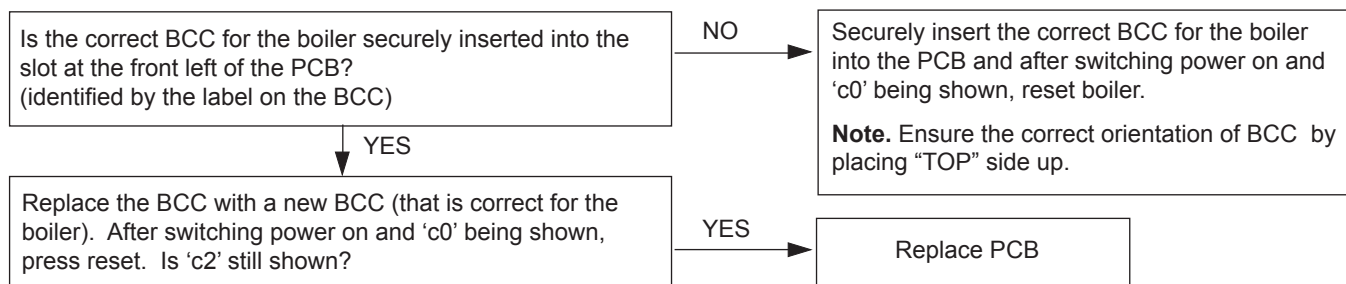

**RESET PROCEDURE** - To reset boiler, turn mode knob to reset position and immediately turn knob back to required setting.

## FAULT FINDING

### 79 NO CH OPERATION

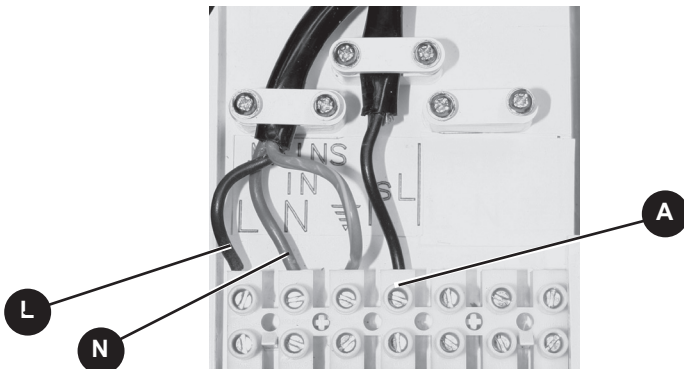
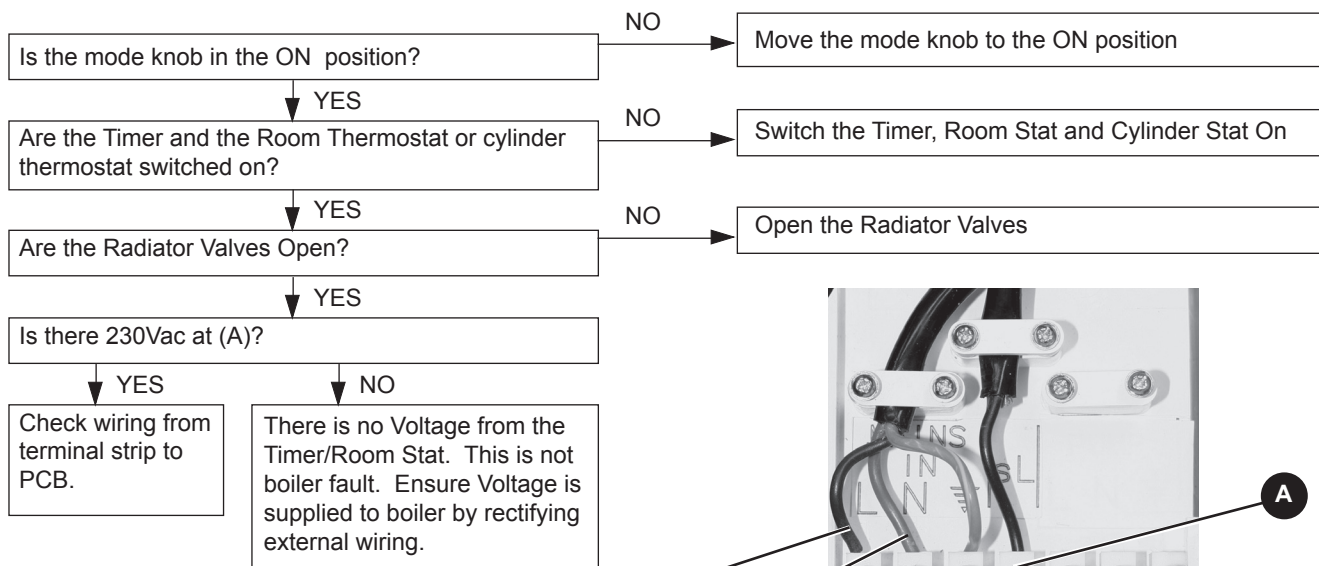

### 80 NO DISPLAY

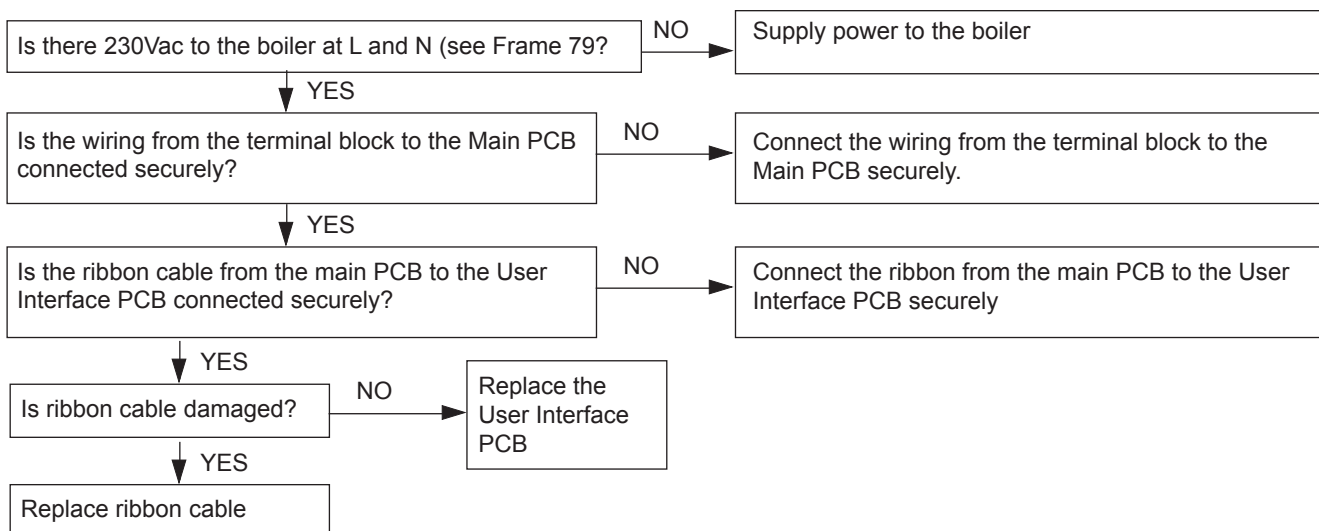

### 81 NO HW

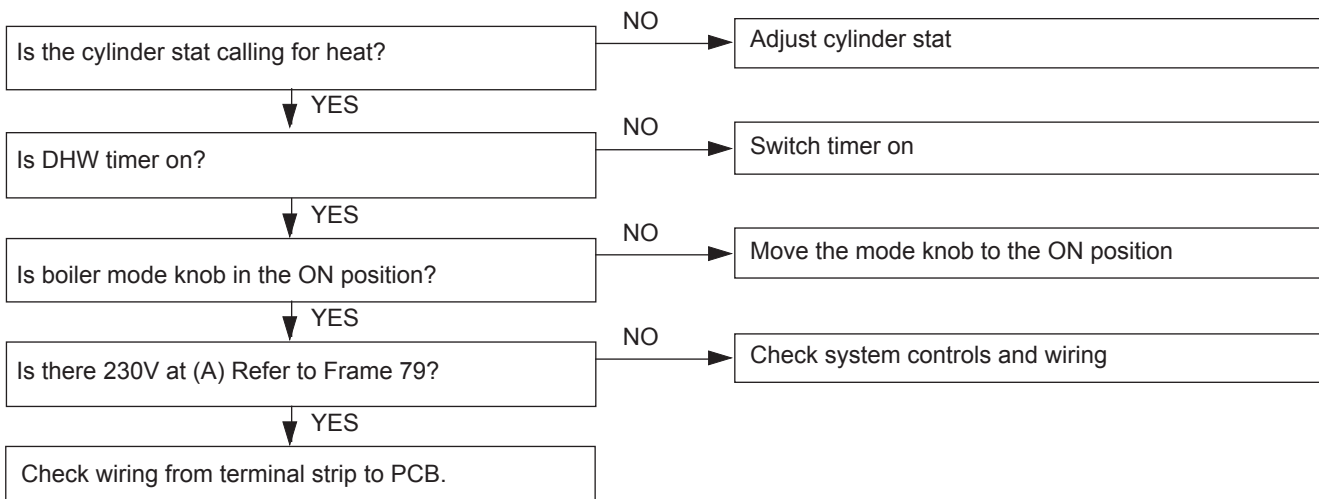

FAULT FINDING FAULT FINDING FAULT FINDING FAULT FINDING

## SHORT LIST OF PARTS

The following are parts commonly required due to damage or expendability. Their failure or absence is likely to affect safety or performance of this appliance.

The list is extracted from the British Gas List of Parts, which contains all available spare parts.

The full list is held by British Gas Services, Ideal Stelrad Group distributors and merchants.

When ordering spares please quote:

1. Boiler model
2. Appliance G.C. No.
3. Description.
4. Quantity.
5. Product number.

When replacing any part on this appliance use only spare parts that you can be assured conform to the safety and performance specification that we require. Do not use reconditioned or copy parts that have not been clearly authorised by Ideal.

\*\*\*\*\* **FOR DIAGRAMS REFER TO FRAME 5 - BOILER ASSEMBLY** \*\*\*\*\*

Key No.	G.C. Part No.	Description	Qty./boiler	Product Number
108		Pump Head Kit	1	175670
110		Automatic Air Vent	1	174894
113		Pressure Relief Valve	1	175413
118		Expansion Vessel	1	176001
131		Water Pressure Sensor	1	175596
135		Pressure Gauge	1	175679
205		Gas Valve kit	1	175562
211		Injector & Housing	1	175566
		15, 18 & 24		
		30	1	175613
215		Fan Kit	1	175569
217		Burner	1	175571
229		Siphon Trap Kit	1	175583
232		Turret Manifold Gasket	1	175620
302		Primary PCB*	1	175935
302A		Boiler Chip Card (BCC)	1	175960
		15	1	175972
		18	1	175961
		24	1	175962
		30	1	175962
303		CUI Board	1	175978
304		Control Thermistor (Return)	2	175589
306		Ignition Electrode Kit	1	175591
307		Detection Electrode Kit	1	175592
308		Spark Generator	1	175593
309		Thermistor - Control / No Flow	1	175594
313		Ignition lead	1	175598
320		Detection Lead	1	175986
328		Fuse - PCB	1	175627
403		Heat Engine Gasket Kit	1	175618
504		Front Casing Panel	1	176002

\* Note that production boiler PCBs are factory pre-set to operate for boiler range and output, but when ordering Primary PCB as a spare, an additional Boiler Chip Card (BCC) MUST also be purchased for your specific boiler range and output.

# Code Of Practice

For the installation, commissioning and servicing of domestic heating and hot water products

Benchmark places responsibilities on both manufacturers and installers.\* The purpose is to ensure that customers\*\* are provided with the correct equipment for their needs, that it is installed, commissioned and serviced in accordance with the manufacturer's instructions by competent persons and that it meets the requirements of the appropriate Building Regulations. Installers are required to carry out work in accordance with the following:

## Standards of Work

- Be competent and qualified to undertake the work required.
- Install, commission, service and use products in accordance with the manufacturer's instructions provided.
- Ensure that where there is responsibility for design work, the installation is correctly sized and fit for purpose.
- Meet the requirements of the appropriate Building Regulations. Where this involves notifiable work be a member of a Competent Persons Scheme or confirm that the customer has notified Local Authority Building Control (LABC), prior to work commencing.
- Complete all relevant sections of the Benchmark Checklist/Service Record when carrying out commissioning or servicing of a product or system.
- Ensure that the product or system is left in a safe condition and, whenever possible, in good working order.
- Highlight to the customer any remedial or improvement work identified during the course of commissioning or servicing work.
- Refer to the manufacturer's helpline where assistance is needed.
- Report product faults and concerns to the manufacturer in a timely manner.

## Customer Service

- Show the customer any identity card that is relevant to the work being carried out prior to commencement or on request.
- Give a full and clear explanation/demonstration of the product or system and its operation to the customer.
- Hand over the manufacturer's instructions, including the Benchmark Checklist, to the customer on completion of an installation.
- Obtain the customer's signature, on the Benchmark Checklist, to confirm satisfactory demonstration and receipt of manufacturer's instructions.
- Advise the customer that regular product servicing is needed, in line with manufacturers' recommendations, to ensure that safety and efficiency is maintained.
- Respond promptly to calls from a customer following completion of work, providing advice and assistance by phone and, if necessary, visiting the customer.
- Rectify any installation problems at no cost to the customer during the installer's guarantee period.



\*The use of the word "installer" is not limited to installation itself and covers those carrying out installation, commissioning and/or servicing of heating and hot water products, or the use of supporting products (such as water treatment or test equipment).

\*\*Customer includes householders, landlords and tenants.







For additional fault finding advice please visit Ideal's website

[www.idealheating.com](http://www.idealheating.com)

### Technical Training

The Ideal Technical Training Centre offers a series of first class training courses for domestic, commercial and industrial heating installers, engineers and system specifiers. For details of courses please ring:..... 01482 498 432



*The code of practice for the installation, commissioning & servicing of central heating systems*



FM 59915

Manufactured under an ISO 9001 registered quality management system

**Ideal Boilers Ltd.**, P.O. Box 103, National Ave, Kingston upon Hull, HU5 4JN. Telephone: 01482 492 251 Fax: 01482 448 858. Registration No. London 322 137.

**Ideal Stelrad Group** pursues a policy of continuing improvement in the design and performance of its products. The right is therefore reserved to vary specification without notice.



Ideal Stelrad Group

***Ideal Installer/Technical Helpline: 01482 498 663***

***[www.idealheating.com](http://www.idealheating.com)***

# USERS GUIDE

---

## LOGIC System 15, 18, 24, 30

For installation guide see reverse of book

When replacing any part on this appliance, use only spare parts that you can be assured conform to the safety and performance specification that we require.  
Do not use reconditioned or copy parts that have not been clearly authorised by Ideal.

# FOR ANY QUERIES PLEASE RING THE IDEAL CONSUMER HELPLINE : 01482 498660

## NOTE. BOILER RESET PROCEDURE -

To reset boiler, turn mode control knob to reset position and immediately turn knob back to required setting.

## Introduction

The **Logic System** is a wall mounted, room sealed, condensing system boiler, featuring full sequence automatic spark ignition and fan assisted combustion.

Due to the high efficiency of the boiler, condensate is produced from the flue gases and this is drained to a suitable disposal point through a plastic waste pipe at the base of the boiler. A condensate 'plume' will also be visible at the flue terminal.

## Safety

### Current Gas Safety (Installation & Use)

#### Regulations or rules in force.

In your own interest, and that of safety, it is the law that this boiler must be installed by a Gas Safe Registered Engineer, in accordance with the above regulations.

In IE, the installation must be carried out by a Registered Gas Installer (RGII) and installed in accordance with the current edition of I.S. 813 "Domestic Gas Installations", the current Building Regulations and reference should be made to the current ETCI rules for electrical installation.

*It is essential that the instructions in this booklet are strictly followed, for safe and economical operation of the boiler.*

## Electricity Supply

**This appliance must be earthed.**

**Supply: 230 V ~ 50 Hz. The fusing should be 3A.**

## Important Notes

- This appliance must not be operated without the casing correctly fitted and forming an adequate seal.
- If the boiler is installed in a compartment then the compartment MUST NOT be used for storage purposes.
- If it is known or suspected that a fault exists on the boiler then it MUST NOT BE USED until the fault has been corrected by a Gas Safe Registered Engineer or in IE a Registered Gas Installer (RGII).
- Under NO circumstances should any of the sealed components on this appliance be used incorrectly or tampered with.
- This appliance is not intended for use by persons (including children) with reduced physical, sensory or mental capabilities, or lack of experience and knowledge, unless they have been given supervision or instructions concerning use of the appliance by a person responsible for their safety.
- Children should be supervised to ensure that they do not play with the appliance.

In cases of repeated or continuous shutdown a Gas Safe Registered Engineer or in IE a Registered Gas Installer (RGII) should be called to investigate and rectify the condition causing this and carry out an operational test. Only the manufacturers original parts should be used for replacement.

## Minimum Clearances

Clearances of **165mm (6 1/2")** above, **100mm (4")** below, **2.5mm (1/8")** at the sides and **450mm (17 3/4")** at the front of the boiler casing must be allowed for servicing.

### Bottom clearance

Bottom clearance after installation can be reduced to 5mm.

This must be obtained with an easily removable panel, to enable the consumer to view the system pressure gauge, and to provide the 100mm clearance required for servicing.

## To light the boiler. Refer to Frame 1

If a programmer is fitted refer to separate instructions for the programmer before continuing.

1. CHECK THAT THE ELECTRICITY SUPPLY TO BOILER IS OFF.
2. Set the mode control knob (B) to 'Off'.
3. Set the Central Heating temperature control (A) to 'max'.
4. Switch ON electricity to the boiler and check that all external controls, e.g. programmer and room thermostat, are ON.
5. Set the mode control knob to ON.

The boiler will commence the ignition sequence supplying heat to the central heating, if required.

**Note.** In normal operation the boiler status display (C) will show codes:

- |          |   |
|----------|---|
| <b>D</b> | Standby - no demand for heat.   |
| <b>E</b> | Heat being supplied.  |
| <b>F</b> | Boiler frost protection - boiler will fire if temperature is below 5 degrees C. |

During normal operation the burner on indicator (D) will remain illuminated when the burner is lit.

Note: If the boiler fails to light after five attempts the fault code L-2 will be displayed.

## RESET PROCEDURE

To reset boiler, turn the mode control knob (B) to reset position and immediately turn knob back to ON. The boiler will repeat the ignition sequence. If the boiler still fails to light consult a Gas Safe Registered Engineer or in IE a Registered Gas Installer (RGII).

## Operation

All Gas Safe Register installers carry a Gas Safe Register ID card, and have a registration number. Both should be recorded in the Benchmark Commissioning Checklist. You can check your installer by calling Gas Safe Register direct on 0800 4085500.

**Ideal Stelrad Group** is a member of the Benchmark scheme and fully supports the aims of the programme. Benchmark has been introduced to improve the standards of installation and commissioning of central heating systems in the UK and to encourage the regular servicing of all central heating systems to ensure safety and efficiency.

**THE BENCHMARK SERVICE INTERVAL RECORD MUST BE COMPLETED AFTER EACH SERVICE**



**Note.** The pump will operate briefly as a self-check once every 24 hours, regardless of system demand.

### Control of water temperature

The boiler controls the central heating radiator temperature to a maximum of 80°C, adjustable via the CH temperature control (A).

The Logic System is a high efficiency condensing boiler which is most efficient when operating in condensing mode.

The boiler will operate in this mode if the CH temperature control (A) is set to the 'e' position (economy mode). This control should be set to maximum for very cold periods

### To shut down the boiler

Set the mode control knob to OFF.

### To relight the boiler

Repeat the procedure detailed in 'To light the boiler'.

### Frost protection

If no system frost protection is provided and frost is likely during a short absence from home, leave the heating controls (if fitted) at a reduced temperature setting. For longer periods, the entire system should be drained.

If the system includes a frost thermostat then, during cold weather, the boiler should be turned OFF at the time switch (if fitted) ONLY. The mains supply should be left switched ON, with the boiler thermostat left in the normal running position.

### Boiler Overheat Protection

The boiler controls will shut down the boiler in the event of overheating. Should this occur, a fault code L-1 will be displayed.

Refer to fault chart.

### Flame Failure

Should this occur a fault code L-2 will be displayed. Refer to fault chart.

### Loss of system water pressure

The gauge (E) indicates the central heating system pressure. If

the pressure is seen to fall below the original installation pressure of 1-2 bar over a period of time then a water leak may be indicated. In this event conduct the re-pressurising procedure as follows:

Re-pressurise via the filling loop to 1 bar (if unsure contact your installer), turn off the tap on the filling loop and turn switch (B) to the reset position and then back on again to reset the boiler.

If unable to do so or if the pressure continues to drop after filling a Gas Safe Registered Engineer or in IE a Registered Gas Installer (RGII) should be consulted.

**NOTE. THE BOILER WILL NOT OPERATE IF PRESSURE HAS REDUCED TO LESS THAN 0.3 BAR UNDER THIS CONDITION.**

### Condensate Drain

The condensate drain (F) must not be modified or blocked.

Blockage of the condensate drain, caused by debris or freezing, can cause automatic shutdown of the boiler.

If freezing is suspected and the pipe run is accessible an attempt may be made to free the obstruction by pouring hot water over the exposed pipe and clearing any blockage from the end of the pipe. If this fails to remedy the problem the assistance of a Gas Safe Registered Engineer or in IE a Registered Gas Installer (RGII) should be sought.

### Escape of gas

Should a gas leak or fault be suspected contact the National Gas Emergency Service without delay. **Telephone 0800 111 999**

**Do NOT search for gas leaks with a naked flame.**

### Cleaning

For normal cleaning simply dust with a dry cloth.

To remove stubborn marks and stains, wipe with a damp cloth and finish off with a dry cloth.

**DO NOT use abrasive cleaning materials.**

### Maintenance

The appliance should be serviced at least once a year by a Gas Safe Registered Engineer or in IE a Registered Gas Installer (RGII).

## 1 BOILER CONTROLS

### Legend

- |                           |                          |                 |
|---------------------------|--------------------------|-----------------|
| A. CH Temperature Control | D. Burner 'on' Indicator | G. Economy Mode |
| B. Mode Control           | E. Pressure Gauge        |                 |
| C. Boiler Status          | F. Condensate Drain      |                 |

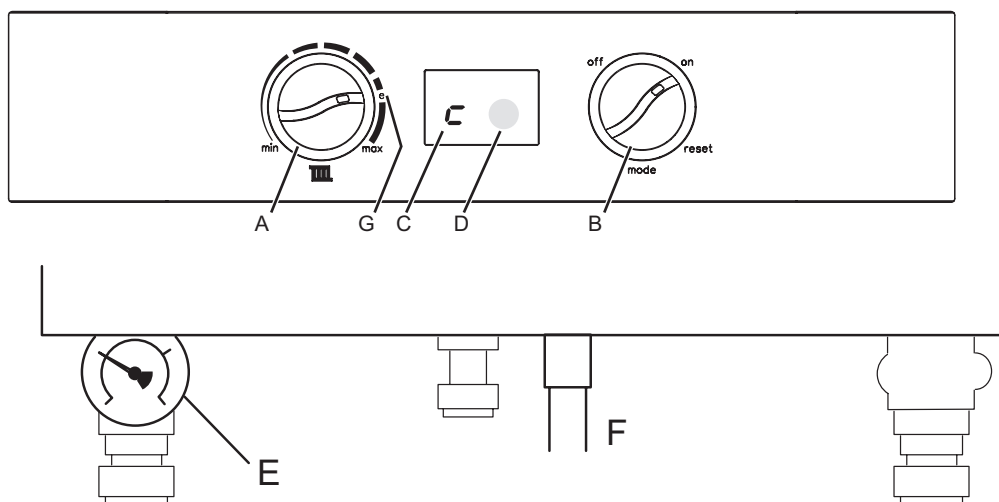



# POINTS FOR THE BOILER USER

**Note.** In line with our current warranty policy we would ask that you check through the following guide to identify any problems external to the boiler prior to requesting a service engineers visit. Should the problem be found to be other than with the appliance we reserve the right to levy a charge for the visit, or for any pre-arranged visit where access is not gained by the engineer.

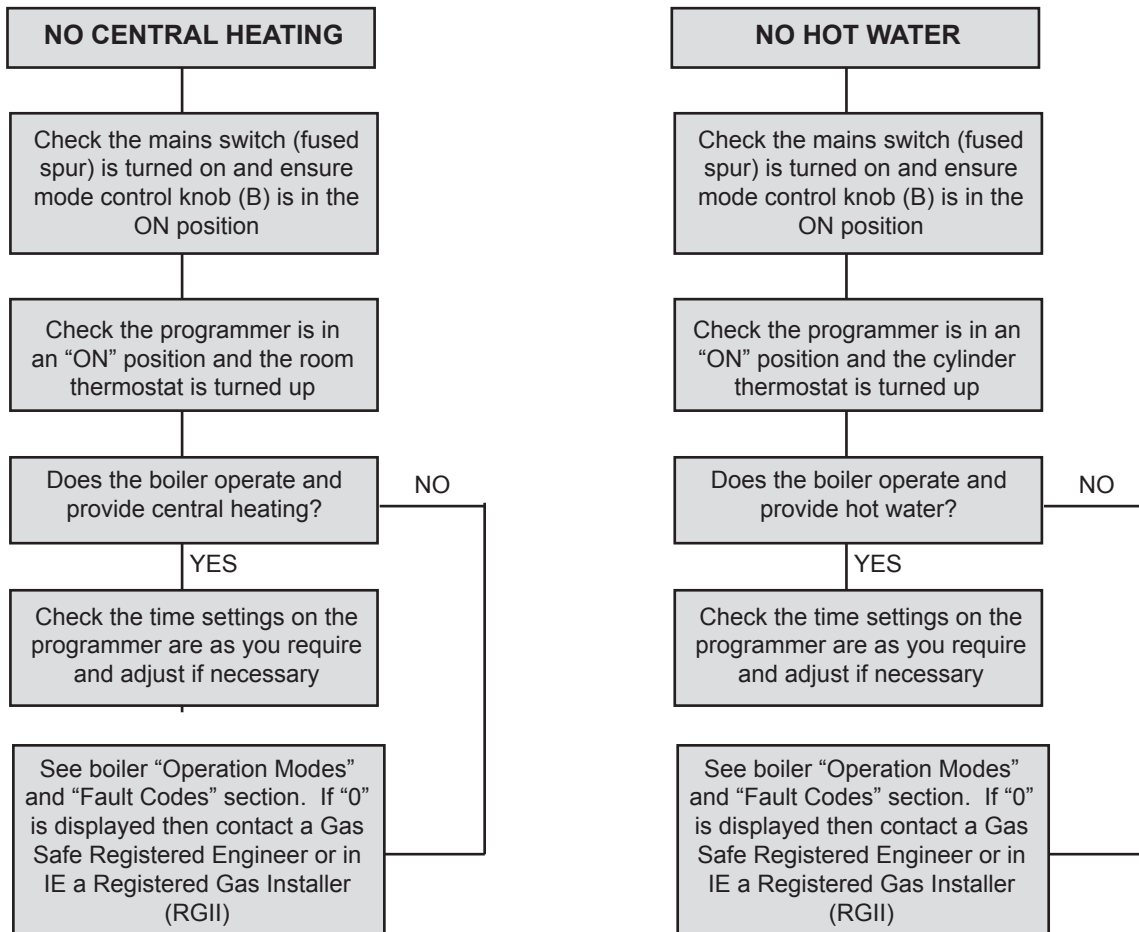
## TROUBLESHOOTING



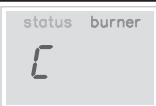
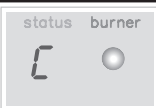







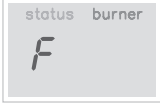











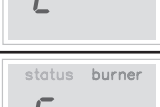
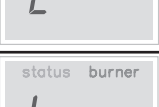
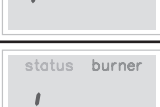
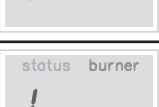
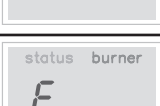
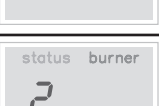
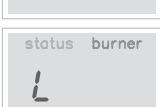
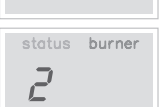

## OPERATION MODES

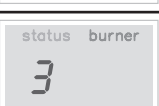
DISPLAY CODE ON BOILER	DESCRIPTION
	The boiler is in standby mode awaiting either a central heating call or hot water demand.
	The boiler has a call for central heating / hot water but the appliance has reached the desired temperature set on the boiler.
	The boiler is operating for central heating / hot water.
	The boiler is operating in frost mode.

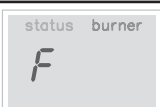
*continued . . . . .*

# FAULT CODES

DISPLAY CODE ON BOILER	DESCRIPTION	ACTION
 	Boiler Chip Card (BCC) Not Fitted	Please contact Ideal (if under warranty) or alternatively a Gas Safe Registered Engineer if outside of the warranty period. In IE contact a Registered Gas Installer (RGII).
 	Outside Sensor Failure	Reset the appliance - if the boiler fails to operate then please contact Ideal (if under warranty) or alternatively a Gas Safe Registered Engineer if outside of the warranty period. In IE contact a Registered Gas Installer (RGII).
 	Low Mains Voltage	Contact a qualified electrician or your electricity provider.
 	PCB Fault	PCB Fault. Please contact Ideal (if under warranty) or alternatively a Gas Safe Registered Engineer if outside of the warranty period. In IE contact a Registered Gas Installer (RGII).
 	5 Boiler Resets in 15 minutes	<ol style="list-style-type: none"> <li>1. Turn power off and on at the fused spur.</li> <li>2. If the boiler fails to operate please contact Ideal (if under warranty) or alternatively a Gas Safe Registered Engineer if outside of the warranty period. In IE contact a Registered Gas Installer (RGII).</li> </ol>
 	False Flame Lockout	Reset the appliance - if the boiler fails to operate then please contact Ideal (if under warranty) or alternatively a Gas Safe Registered Engineer if outside of the warranty period. In IE contact a Registered Gas Installer (RGII).
 	BCC Activation Fault	Reset the appliance - if the boiler fails to operate then please contact Ideal (if under warranty) or alternatively a Gas Safe Registered Engineer if outside of the warranty period. In IE contact a Registered Gas Installer (RGII).
 	BCC Fault	
 	Low Water Pressure	Check system pressure is between 1 & 1.5bar on the pressure gauge. If the boiler fails to operate then please contact Ideal (if under warranty) or alternatively a Gas Safe Registered Engineer if outside of the warranty period. In IE contact a Registered Gas Installer (RGII).
 	Flow Temperature Overheat	
   	Flame Loss	<ol style="list-style-type: none"> <li>1. Check other gas appliances in the house are working to confirm a supply is present in the property.</li> <li>2. If other appliances do not work or there are no other appliances, check the gas supply is on at the meter and/or pre payment meter has credit. If the boiler fails to operate then please contact Ideal (if under warranty) or alternatively a Gas Safe Registered Engineer if outside of the warranty period. In IE contact a Registered Gas Installer (RGII).</li> </ol>
 	Fan Fault	Reset the appliance - if the boiler fails to operate then please contact Ideal (if under warranty) or alternatively a Gas Safe Registered Engineer if outside of the warranty period. In IE contact a Registered Gas Installer (RGII).
 	Control / No Flow Thermistor	Reset the appliance - if the boiler fails to operate then please contact Ideal (if under warranty) or alternatively a Gas Safe Registered Engineer if outside of the warranty period. In IE contact a Registered Gas Installer (RGII).
 	Return Thermistor	Reset the appliance - if the boiler fails to operate then please contact Ideal (if under warranty) or alternatively a Gas Safe Registered Engineer if outside of the warranty period. In IE contact a Registered Gas Installer (RGII).



***Ideal Consumer Helpline***  
***Tel: 01482 498660***  
***www.idealheating.com***

**Ideal Stelrad Group** pursues a policy of continuing improvement in the design and performance of its products. The right is therefore reserved to vary specification without notice.

**Ideal**, P.O. Box 103, National Ave, Kingston Upon Hull, HU5 4JN.  
Tel. 01482 492251 Fax. 01482 448858. Registration No. London 322 137.

