

IDEAL ELAN 2

RS 230, 240, 250, 260 & 275

CF 230, 240, 250 & 260

Wall Mounted Gas Boilers.

User's Instructions.

CAUTION: To avoid the possibility of injury during the installation, servicing or cleaning of this appliance, care should be taken when handling edges of sheet steel components.

IMPORTANT: The appliances are for use with
NATURAL GAS ONLY.

Ideal Elan 2	G.C. Number
RS 230	41 429 51
RS 240	41 429 52
RS 250	41 429 53
RS 260	41 429 54
RS 275	41 429 55

Ideal Elan 2	G.C. Number
CF 230	41 429 56
CF 240	41 429 57
CF 250	41 429 58
CF 260	41 429 59

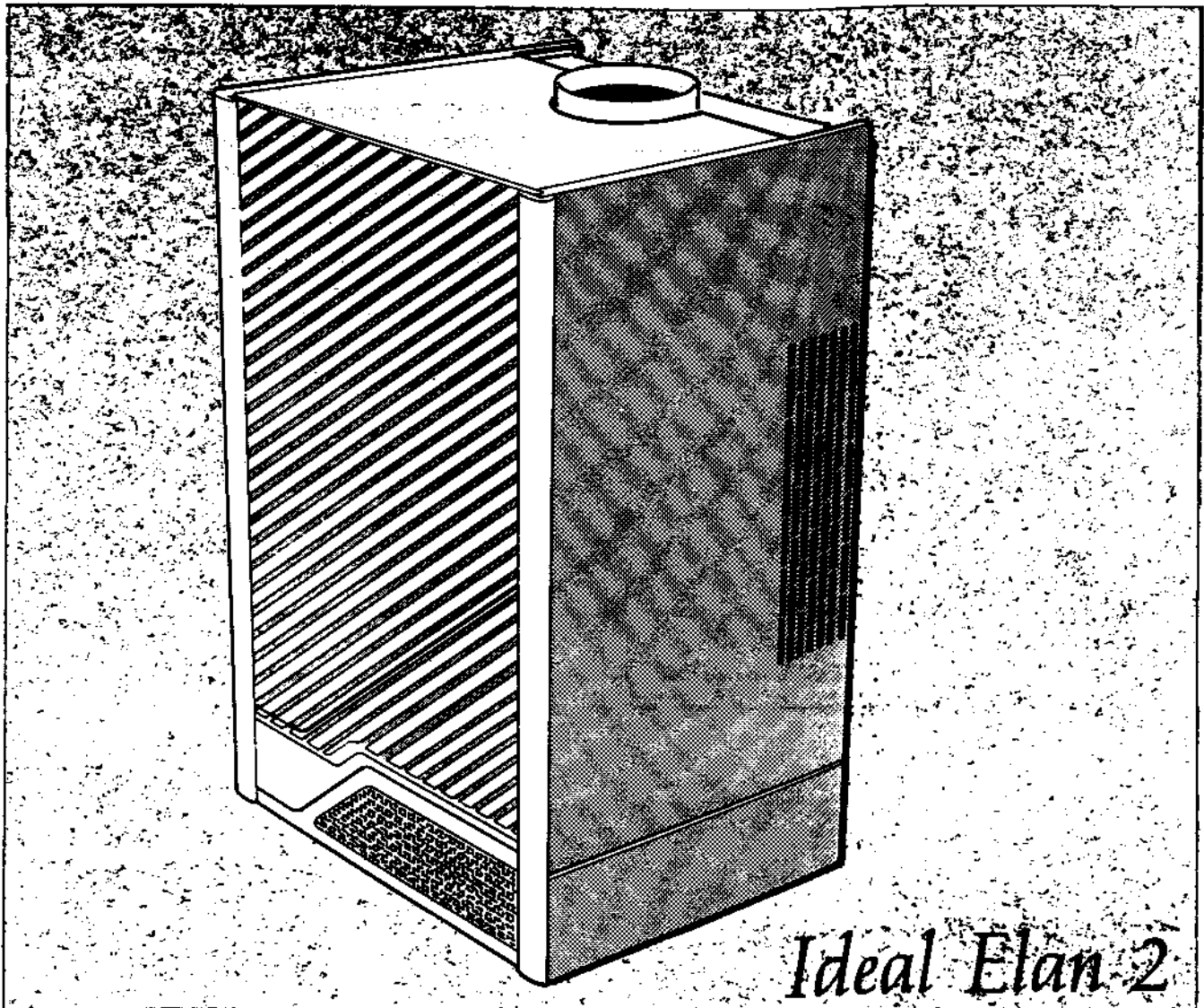

Ideal Elan 2

NOTE TO THE INSTALLER: PLACE THESE INSTRUCTIONS WITH THE HOUSEHOLDER



The Gas Safety (Installation and Use) Regulations: 1984 impose certain statutory obligations on gas users. Further information may be obtained on application to the Gas Region.

It is the law that all gas appliances are installed by competent persons, e.g. CORGI (identified by ) , in accordance with the above regulations. Failure to install appliances correctly could lead to prosecution. It is in your own interest, and that of safety, to ensure that the law is complied with.

ELECTRICAL SUPPLY

If a mains plug is used it **MUST** be of the 3-pin type, wired as shown in Fig.1 and fused at 3 A.

*The appliance **MUST** be efficiently earthed.*

As the colour of the wires in the mains lead of this appliance may not correspond with the coloured markings identifying the terminals in your plug, proceed as follows:

The wire which is coloured **GREEN AND YELLOW** must be connected to the terminal in the plug which is marked with the letter 'E' or by the earth symbol '⏏' or coloured **GREEN** or **GREEN AND YELLOW**.

The wire which is coloured **BLUE** must be connected to the terminal which is marked with the letter 'N' or coloured **BLACK**.

The wire which is coloured **BROWN** must be connected to the terminal which is marked with the letter 'L' or coloured **RED**.

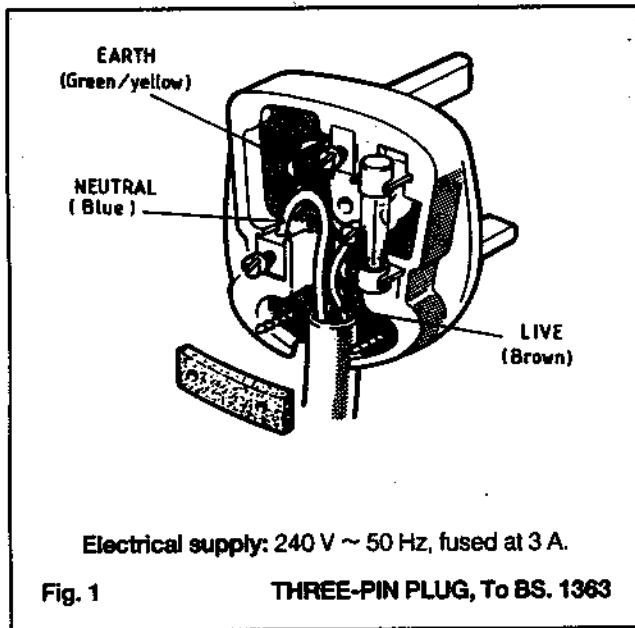

MINIMUM SERVICING SIZES

The minimum clearances given below **MUST** be complied with in order to maintain the safe running of the boiler and to facilitate servicing.

	RS Boilers
Above the boiler	100 mm (4 in.)
At each side of the boiler	10 mm (1/2 in.)
Underneath the boiler	100 mm (4 in.)
	CF Boilers
Above the boiler	100 mm (4 in.)
At each side of the boiler	25 mm (1 in.)
Underneath the boiler	100 mm (4 in.)

In addition a **MINIMUM** clearance of 450 mm (13 in.) **MUST** be available at the

CF Boilers only. The above clearances must always be maintained between the boiler and nearby objects on the wall in order to ensure the correct operation of the draught diverter.

IMPORTANT. THIS APPLIANCE MUST NOT BE OPERATED WITHOUT THE CASING CORRECTLY FITTED.

If the boiler is installed in a compartment, then the compartment **MUST NOT** be used for storage purposes.

The ventilation provided for the boiler during installation **MUST NOT** be blocked and a check should be made periodically to ensure that the ventilation areas are free from any obstruction.

If it is known or suspected that a fault exists on the boiler it **MUST NOT** be used until the fault has been corrected by a competent person.

It is essential that the instructions in this booklet are strictly followed for the safe and economical operation of the boiler.

TO LIGHT THE BOILER, Refer to Fig. 2.

1. Check that the electricity supply to the boiler is OFF.
2. Slide the glass fascia upwards until it locates in the retention catch (E).
3. Ensure that the boiler thermostat knob (C) is in the OFF position.
4. Slide the gas control button (B) to the right until resistance is felt and then release it. Wait for 3 minutes.
5. Push in and retain fully depressed the gas control button (B). Press and release ignition button (D) repeatedly until the pilot flame can be seen through the sightglass (A). When the pilot has lit, continue to press in the gas control button for a further 15 seconds.
6. Should the pilot go out at this or any other stage, slide the gas control button (B) to the right and release it. Wait for 3 minutes and then repeat instruction 5, but wait for longer than 15 seconds before releasing the gas control button.
7. Switch ON the electricity supply to the boiler and check that all external controls, e.g. room thermostat etc., are ON and calling for heat.
8. Set the boiler thermostat knob (C) to position '6' and the will light.
For **WINTER CONDITIONS** (central heating and domestic hot water) the thermostat should be set to position '6'.
For **SUMMER CONDITIONS** (domestic hot water only) the thermostat may be set lower as required.
9. Lift the glass fascia slightly, release the retaining catch (E) and slide the glass fascia down.

Approximate flow temperatures for the boiler thermostat settings are;

Knob Setting	Flow Temperature	
	°C	°F
1	56	133
2	61	142
3	66	152
4	72	161
5	77	170
6	82	180

TO SHUT DOWN THE BOILER

1. **For Short Periods:**
Set the boiler thermostat knob (C) to OFF. When heating is again required – restore the knob to its original setting.
2. **For Longer Periods:**
 - (a) Set the boiler thermostat knob (C) to OFF.
 - (b) Slide the gas control button (B) to the RIGHT until resistance is felt and then release it to extinguish the pilot burner.
 - (c) Switch the electricity supply to OFF.

WARNING. If no frost protection is provided and frost is likely during a short absence from home, leave the heating controls (if fitted) at a reduced temperature setting.

For longer periods the entire system should be drained, including the domestic water supply.

If the system includes a frost thermostat then, during cold weather, the boiler should be turned OFF at the time control selector switch(es) ONLY. The mains supply should be left switched ON and all other controls should remain in their normal running positions.

BOILER OVERHEAT THERMOSTAT

The boiler is fitted with a safety 'cut out' thermostat which will interrupt the gas supply to the boiler and shut it down in the event of overheating.

Should this occur, allow the boiler to cool and then re-light as detailed in steps 1 to 9 under 'To Light the Boiler'.

If the 'cut-out' condition persists, turn off the boiler and consult your local Heating Installer.

CONTROL OF WATER TEMPERATURE

1. Set the boiler thermostat knob to give the required temperature.
2. The boiler thermostat automatically switches the main burner OFF and ON to maintain the selected temperature.
3. The pilot burner remains alight continuously to give re-ignition of the main burner.

TO RELIGHT THE BOILER

Repeat procedures 1 to 9 detailed in 'To Light to Boiler'.

ESCAPE OF GAS

Should a gas leak or fault be suspected then turn Off the supply and contact your local Gas Region or service Engineer *hour delay*.

Do NOT search for gas leaks with a naked flame.

CLEANING

For normal cleaning, simply dust with a dry cloth.

To remove stubborn marks and stains, wipe with a damp cloth and finish off with a dry cloth.

Do NOT use abrasive cleaning materials.

MAINTENANCE

The appliance should be SERVICED AT LEAST ONCE A YEAR by a qualified Heating Engineer or your local Gas Region.

LEGEND

- A Sightglass.
- B Gas control button.
- C Boiler thermostat knob.
- D Piezo ignition button.
- E Fascia retaining catch.

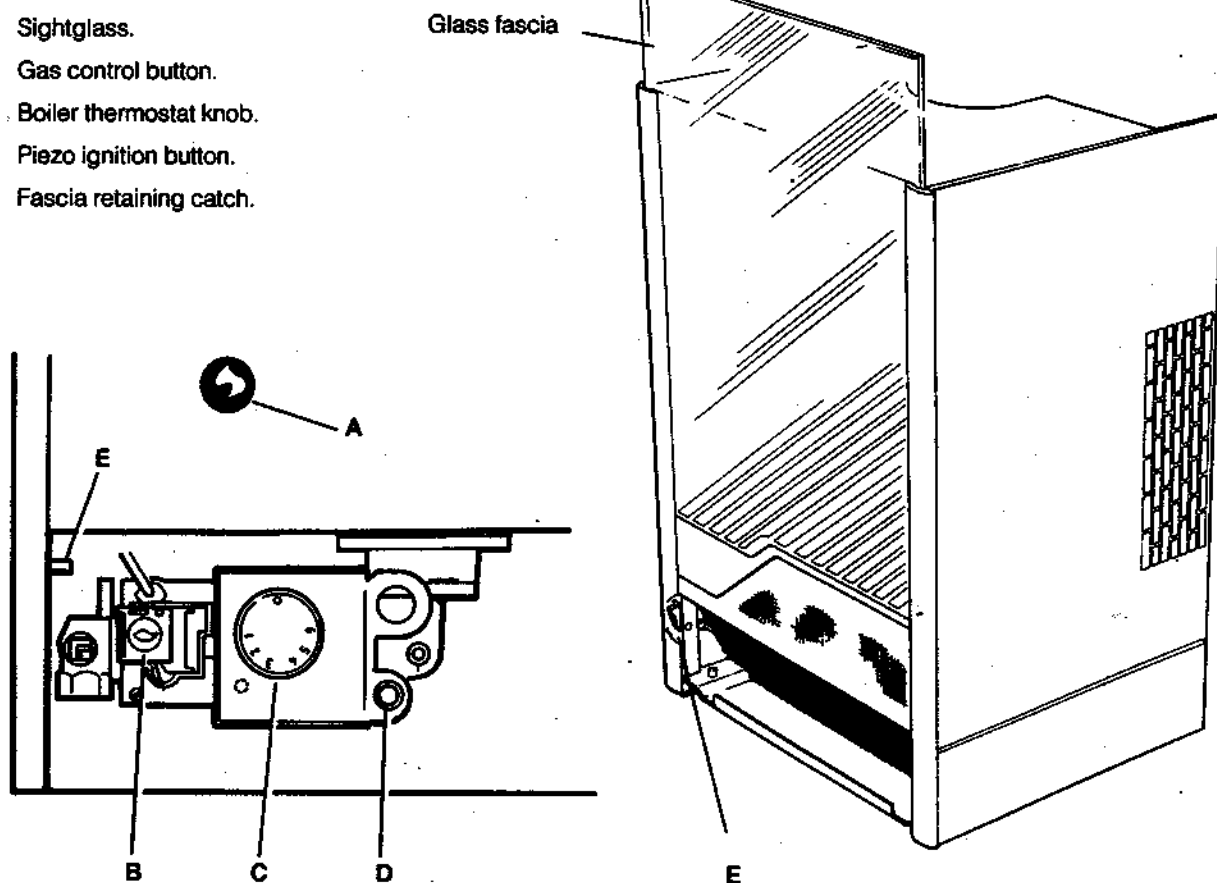

Fig. 2

CF boiler shown

BOILER CONTROLS



**THIS SYMBOL IS YOUR
ASSURANCE OF QUALITY**

These appliances are designed for use with Natural Gas only. They have been tested and conform with the provisions of BS. 6332 and BS. 5258.

Products bearing this Kitemark are made to a safety and performance standard under a stringent scheme of supervision and control monitored by the British Standards Institute.

CARADON IDEAL Ltd. pursues a policy of continuing improvement in the design and performance of its products. The right is therefore reserved to vary specification without notice.

CARADON IDEAL Ltd.

P.O. Box 103, National Avenue,
Kingston upon Hull,
North Humberside. HU5 4JN.

Telephone: 01482 492 251

Fax: 01482 448 858.

Registration No. London 322 137.

Registered Office: National Avenue, Kingston upon Hull,
North Humberside, HU5 4JN.

A subsidiary of Caradon p.l.c

August 1994 116 800 A02

BOILERS
Ideal

Customer Care & Technical Support

Please use the following numbers for speedy assistance.

Spares. Tel: 01482 498 643

**Customer Care &
Technical Support.** Tel: 01482 498 610

..... Fax: 01482 498 666

Publications/literature. Tel: 01482 498 467