

IDEAL ELAN 2 NF 230, NF 240, NF 250, NF 260 & NF 280 Wall Mounted, Fanned, Balanced Flue Gas Boilers. Installation & Servicing.

CAUTION: To avoid the possibility of injury during the installation, servicing or cleaning of this appliance, care should be taken when handling edges of sheet steel components.

IMPORTANT: The appliances are for use with **NATURAL GAS ONLY.**

Ideal Elan 2

NF 230
NF 240
NF 250
NF 260
NF 280

G.C. Number

41 429 60
41 429 61
41 429 62
41 429 63
41 429 64

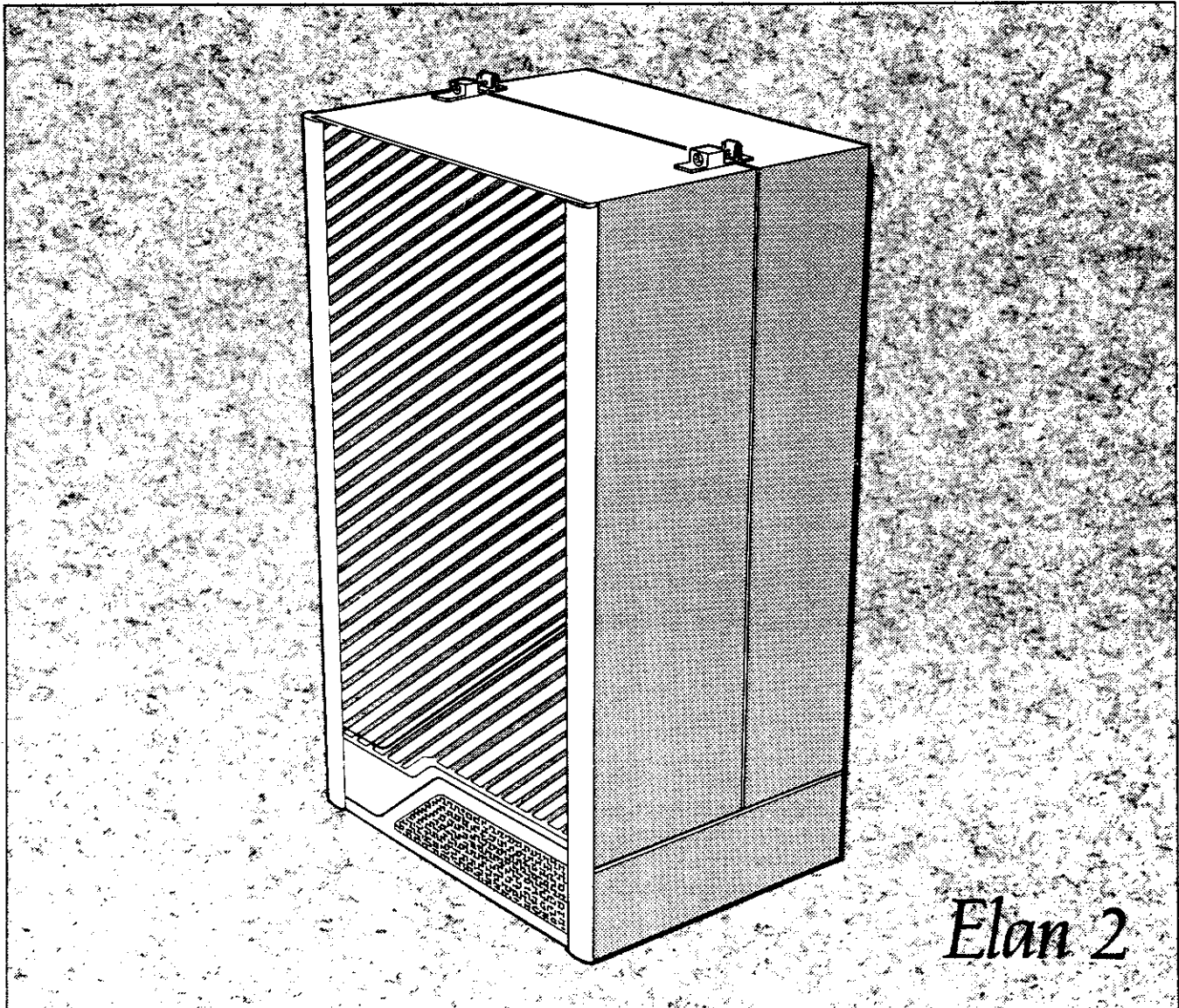

NOTE TO THE INSTALLER: Leave these instructions adjacent to the gas meter or with the user

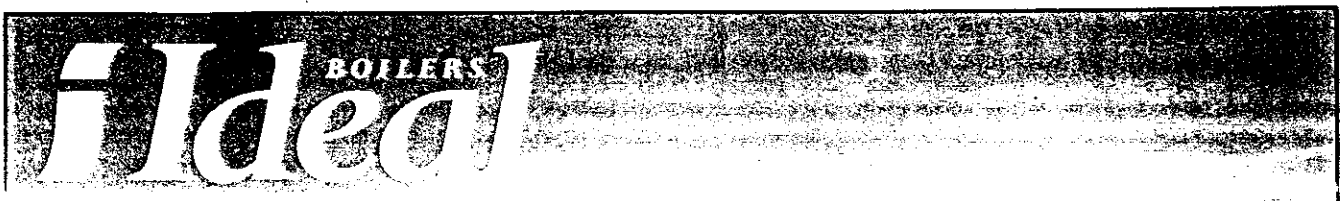

GENERAL

PERFORMANCE DATA

Table 1- GENERAL DATA

Boiler Size		NF 230	NF 240	NF 250	NF 260	NF 280
Main burner bar		Aeromatic AC 19/123 278	Aeromatic AC 19/123 279	Aeromatic AC 19/123 276		Aeromatic AC 19/123 277
Gas control		HONEYWELL VR 4700 E 1042, 240 V				
Burner injector BRAY		Cat. 16 size 750	Cat. 16 size 1100	Cat. 16 size 1400	Cat. 16 size 1700	Cat. 10 size 2400
Pilot injector HONEYWELL		45900421 - 001 STAMPED 38 / 36A		45900421 - 002 STAMPED 56 / 42A		
Gas supply connection (in. BSP)		Rc 1/2 (1/2)				
Flow connection Compression fittings		22 mm				28 mm
Return connection Compression fittings		22 mm				28 mm
Maximum static water head m (ft.)		30.5 (100)				
Minimum static water head m (ft.)		0.45 (1.5)				
Electrical supply		240 V ~ 50 Hz Boiler power consumption; 50 W				
Fuse rating		External; 3 A		Internal; F1 A to BS. 4265		
Water content litre (gal.)		1.0 (0.22)		1.2 (0.27)		1.5 (0.33)
Dry weight kg (lb)		26.3 (58.0)		27.5 (60.6)		35.0 (77.2)
Maximum installation weight kg (lb)		16.0 (35.3)		17.2 (37.9)		22.9 (50.5)
Boiler size	Height mm (in.)	700 (27.5)				
	Width mm (in.)	380 (15)				465 (18)
	Depth mm (in.)	300 (12)				
Flue duct diameter mm (in.)		100 (4)				

Table 2- PERFORMANCE DATA

Boiler Size		NF 230	NF 240	NF 250	NF 260	NF 280
Boiler input	MINIMUM kW	5.9	11.7	15.2	19.0	23.4
	(Btu/h)	(20 300)	(40 000)	(51 900)	(64 900)	(80 000)
To obtain gas consumption	Gas consumption l/s (ft ³ /h)	0.15 (19.5)	0.30 (38.5)	0.39 (50.0)	0.49 (62.5)	0.60 (77.1)
(a) For l/s; divide heat input (kW) by C.V. of the gas (MJ/m ³).	MID kW	8.6	13.3	16.9	20.7	26.6
	(Btu/h)	(29 400)	(45 500)	(57 700)	(70 500)	(90 900)
(b) For ft ³ /h; divide heat input (Btu/h) by C.V. of the gas (Btu/ft ³).	Gas consumption l/s (ft ³ /h)	0.22 (28.3)	0.34 (43.8)	0.44 (55.6)	0.53 (67.9)	0.69 (87.6)
	MAXIMUM kW	11.1	14.8	18.6	22.2	29.7
Heat inputs are pre-set to the highest nominal rating.	(Btu/h)	(38 000)	(50 600)	(63 300)	(75 900)	(101 300)
	Gas Consumption l/s (ft ³ /h)	0.29 (36.6)	0.38 (48.7)	0.48 (61.0)	0.57 (73.1)	0.77 (97.6)
Boiler output	MINIMUM kW	4.4	8.8	11.7	14.7	17.6
	(Btu/h)	(15 000)	(30 000)	(40 000)	(50 000)	(60 000)
	MID kW	6.6	10.3	13.2	16.1	20.5
	(Btu/h)	(22 500)	(35 000)	(45 000)	(55 000)	(70 000)
	MAXIMUM kW	8.8	11.7	14.7	17.6	23.4
Burner setting pressure (HOT)	(Btu/h)	(30 000)	(40 000)	(50 000)	(60 000)	(80 000)
	MINIMUM mbar (in.w.g.)	5.0 (2.0)	9.2 (3.7)	9.7 (3.9)	10.2 (4.1)	9.5 (3.8)
	MID mbar (in.w.g.)	10.1 (4.0)	11.8 (4.7)	11.9 (4.8)	12.0 (4.8)	12.3 (4.9)
	MAXIMUM mbar (in.w.g.)	16.6 (6.7)	14.6 (5.9)	14.0 (5.6)	13.8 (5.5)	15.2 (6.1)

GENERAL

INTRODUCTION

The **Ideal Elan 2** NF 230, NF 240, NF 250, NF 260 and NF 280 are fully automatically controlled, wall mounted, low water content, balanced flue, fanned gas boilers.

They are range rated to provide central heating outputs of 4.4 kW (15 000 Btu/h) to 23.4 kW (80 000 Btu/h).

The boiler casing is of white enamelled mild steel, with a fascia of satinised white glass. The controls pod, also of white enamelled mild steel, has fixed sides and a removable bottom panel.

The glass fascia slides upwards to reveal the boiler thermostat (in the control box mounted on the gas valve) and the programmer (if fitted).

A **Programmer Kit**, which fits neatly within the casing, is available as an optional extra. Separate fitting instructions are included with this kit.

The boilers are supplied with a standard flue kit suitable for rear or side outlet applications from 114mm (4 1/2 in.) to 406 mm (16 in.).

Up to 3 optional **Flue Extension Duct Kits** allowing up to 3 m (118 in.), rear or side outlet, are available.

A **Vertex Flue Kit**, for vertical flue connection is available as an optional extra.

A **90g Flue Elbow Kit**, is also available.

The boilers are suitable for connection to fully pumped, open vented or sealed water systems. Adequate arrangements for completely draining the system by provision of drain cocks, **MUST** be provided in the installation pipework.

Gas Safety (Installation and Use) Regulations, 1984.

It is the law that all gas appliances are installed by competent persons (e.g. CORGI, identified by ) , in accordance with the above Regulations. Failure to install appliances correctly could lead to prosecution. It is in your own interest, and that of safety, to ensure that the law is complied with.

The installation of the boiler **MUST** also be in accordance with the current I.E.E. Wiring Regulations, the Local Building Regulations, Building Standards (Scotland), the bye laws of the Local Water Undertaking and any relevant requirements of the Local Authority.

Detailed recommendations are contained in the following British Standard Codes of Practice.

BS. 6891	Low pressure installation pipes.
BS. 6798	Installation of gas fired hot water boilers of rated input not exceeding 60kW.
BS. 5449	Forced circulation hot water systems.
BS. 5546	Installation of gas hot water supplied for domestic purposes (2nd Family Gases).
BS. 5440:1	Flues (for gas appliances of rated input not exceeding 60kW).
BS. 5440:2	Ventilation (for gas appliances of rated input not exceeding 60kW).

Manufacturers' notes must not be taken in any way as overriding statutory obligations.

IMPORTANT. These appliances are certificated by the British Standards Institution for safety and performance. It is, therefore, important that no external control devices, e.g. flue dampers, economisers etc., are directly connected to

INTRODUCTION - GAS SUPPLY

Any direct connection of a control device not approved by Caradon Heating Ltd. could invalidate the B.S.I. Certification and the normal appliance warranty. It could also infringe the Gas Safety Regulations and the above regulations.

LOCATION OF BOILER

The boiler **MUST** be installed on a flat and vertical non-combustible wall, capable of adequately supporting the weight of the boiler and any ancillary equipment.

THE BOILER IS NOT SUITABLE FOR EXTERNAL INSTALLTION

IMPORTANT NOTICE. If the boiler is to be fitted in a timber framed building it should be fitted in accordance, with the British Gas publication 'Guide for Gas Installations in Timber Frame Housing', Reference DM2. If in doubt advice must be sought from the local Gas Region of British Gas.

The boiler may be installed in any room or internal space, although particular attention is drawn to the requirements of the current I.E.E. Wiring Regulation and, in Scotland, the electrical provisions of the Building Regulations applicable in Scotland with respect to the installation of the boiler in a room or internal space containing a bath or shower.

Where a room sealed appliance is installed in a room containing a bath or shower then the appliance and any electrical switch or appliance control utilising mains electricity should be so situated that it cannot be touched by a person using the bath or shower.

Where installation will be in an unusual location, special procedures may be necessary and BS. 6798 gives detailed guidance on this aspect.

A compartment used to enclose the boiler **MUST** be designed and constructed specially for this purpose. An existing cupboard or compartment may be used, provided it is modified for the purpose. Details of essential features of cupboards / compartment design, including airing cupboards installation are given in BS. 6798.

In siting the boiler, the following limitations **MUST** be observed:

1. The position selected for installation **MUST** allow adequate space for servicing in front of the boiler and for air circulation around the boiler. For the minimum clearances required for safety and subsequent service, see the Wall Mounting Template and Frame 4. In addition sufficient space may be required to allow lifting access on to the wall mounting plate.
2. This position **MUST** also permit the provision of a satisfactory flue termination.

GAS SUPPLY

The Local Gas Region should be consulted, at the installation planning stage, in order to establish the availability of an adequate supply of gas.

An existing service pipe must **NOT** be used without prior consultation with the Local gas region.

A gas meter can only be connected by the Local Gas Region, or by a local Gas Region Contractor. An existing meter should be checked, preferably by the Gas Region, to ensure the meter is adequate to deal with the rate of gas supply required.

Installation pipes should be fitted in accordance with BS. 6891. Pipework from the meter to the boiler **MUST** be of an adequate size. Do **NOT** use pipes of a smaller size than the boiler inlet pipe connection.

GENERAL

FLUE INSTALLATION

The flue **MUST** be installed in accordance with the recommendations of BS 5440: 1.

The following notes are intended for general guidance.

1. The boiler **MUST** be installed so that the terminal is exposed to the external air.
2. It is important that the position of the terminal allows the free passage of air across it at all times.
3. The minimum acceptable spacing from the terminal to obstructions and ventilation openings are specified in Table 3.
4. Where the lowest part of the terminal is fitted less than 2 m (6.6 ft.) above a balcony, above ground or above a flat roof to which people have access then the terminal **MUST** be protected by a purpose designed guard.

Terminal guards are available from:

Quinnel, Barret & Quinnel Ltd.,
884 Old Kent Road, London, SE15 (Model 304),
Telephone No. 071 6391357,
and from,

Tower Flue Components Ltd.,
Vale Rise, Tonbridge, Kent, TN9 1TB (Model K1),
Telephone No. 0732 351555.

Ensure that the guard is fitted centrally.

5. Where the terminal is fitted within 850 mm (34 in.) of a plastic or painted gutter, or 450 mm (18 in.) of painted eaves then an aluminium shield at least 750 mm (30 in.) long should be fitted to the underside of the gutter or painted surface.
6. The air inlet / products outlet duct and the terminal of the boiler **MUST NOT** be closer than 25 mm (1 in.) to combustible material. Detailed recommendations on the protection of combustible material are given in BS. 5440:1 1990.
7. If the terminal is fitted less than 2 m (6 ft. 6 in.) above a balcony, above ground or above a flat roof then the minimum spacing in Table 3, No.s 2, 3, 5 and 6 would be 75 mm in order to allow a terminal guard to be fitted.
8. Where it is essential that the terminal wall plate is fitted, i.e. wall thicknesses over 610 mm (24 in.) or with an inaccurately cut hole, the minimum spacing in Table 3, No.s 2, 3, 5 and 6 would be 60 mm in order to allow the terminal wall plate to be fitted.

IMPORTANT. It is absolutely **ESSENTIAL** to ensure, in practice, that products of combustion discharging from the terminal cannot re-enter the building or any other adjacent building through ventilators, windows, doors, other sources of natural air infiltration, or forced ventilation / air conditioning.

*If this should occur, the appliance **MUST** be turned OFF immediately and the Local Gas Region consulted.*

TERMINAL

The flue terminal assembly can be adapted to accommodate various wall thicknesses and flue lengths. Refer to Frame 3.

AIR SUPPLY

Detailed recommendations for air supply are given in BS. 5440: 2. The following notes are for general guidance:

1. It is **NOT** necessary to have a purpose provided air vent in the room or internal space in which the boiler is installed.

FLUE INSTALLATION - AIR SUPPLY

2. If the boiler is to be installed in a cupboard or compartment, permanent air vents are required (for cooling purposes) in the cupboard/ compartment, at both high and low levels. The air vents must either communicate with room/internal space, or be direct to outside air. The minimum effective areas of the permanent air vents, required in the cupboard/ compartment, are specified as follows and are related to maximum rated heat input.
3. Both air vents **MUST** communicate with the same room or internal space, or **MUST** be on the same wall to outside air.
4. In siting the air vents care must be taken to avoid the freezing of pipework.

Refer to Tables 4, 5, 6, 7 & 8 for details of air vent position and sizing.

Table 3 - BALANCED FLUE TERMINAL POSITION

Terminal Position	Minimum Spacing
1. Directly below an openable window, air vent or other ventilation opening.	300 mm (12 in.)
2. Below guttering, drain pipes or soil pipes.	25 mm (1 in.)
3. Below eaves.	25 mm (1 in.)
4. Below balconies or a car port roof.	25 mm (1 in.)
5. From vertical drain pipes or soil pipes.	25 mm (1 in.)
6. From internal or external corners.	25 mm (1 in.)
7. Above adjacent ground, roof or balcony level.	300 mm (12 in.)
8. From a surface facing the terminal.	600 mm (24 in.)
9. From a terminal facing a terminal.	1200 mm (48 in.)
10. From an opening in a car port (eg. door or window) into dwelling.	1200 mm (48 in.)
11. Vertically from a terminal on the same wall.	1500 mm (60 in.)
12. Horizontally from a terminal on the wall.	300 mm (12 in.)

Table 4 - NF 230 AIR SUPPLY

Position of air vent	Air from room/ internal space	Air direct from outside
HIGH LEVEL	cm ² (in ²)	100 (16)
LOW LEVEL	cm ² (in ²)	100 (16)
		50 (8)
		50 (8)

Table 5 - NF 240 AIR SUPPLY

Position of air vent	Air from room/ internal space	Air direct from outside
HIGH LEVEL	cm ² (in ²)	133 (21)
LOW LEVEL	cm ² (in ²)	133 (21)
		67 (11)
		67 (11)

GENERAL

Table 6 - NF 250 AIR SUPPLY

Position of air vent	Air from room/ internal space	Air direct from outside
HIGH LEVEL cm ² (in ²)	166 (26)	83 (13)
LOW LEVEL cm ² (in ²)	166 (26)	83 (13)

Table 7 - NF 260 AIR SUPPLY

Position of air vent	Air from room/ internal space	Air direct from outside
HIGH LEVEL cm ² (in ²)	200 (30)	100 (15)
LOW LEVEL cm ² (in ²)	200 (30)	100 (15)

Table 8 - NF 280 AIR SUPPLY

Position of air vent	Air from room/ internal space	Air direct from outside
HIGH LEVEL cm ² (in ²)	264 (40)	132 (20)
LOW LEVEL cm ² (in ²)	264 (40)	132 (20)

Table 9 - WATER FLOW RATE AND PRESSURE LOSS

Boiler Size	NF 230	NF 240	NF 250	NF 260	NF 280
Boiler output kW	8.8	11.7	14.7	17.6	23.4
Btu/h	30 000	40 000	50 000	60 000	80 000
Water flow rate l/min	11.4	15.2	19.0	22.8	30.3
gal/h	150	200	250	300	400
Pressure loss mbar	27	45	70	102	92
in. w.g.	11	18	28	41	37

WATER CIRCULATION SYSTEM

The boiler must NOT be used for direct hot water supply.

The boiler is suitable for connection to fully pumped open vented or sealed water central heating systems or central heating combined with indirect domestic hot water systems.

The central heating system should be in accordance with BS. 6798 and in addition, for Smallbore and Microbore systems, BS. 5449

The domestic hot water system, if applicable, should be in accordance with relevant recommendations to BS. 5546.

Copper tubing to BS. 2871: 1 is recommended for water carrying pipework.

The hot water storage cylinder MUST be of the indirect type and should be, preferably, manufactured of copper.

Single-feed indirect cylinders are not recommended and should not be used in indirect systems.

AIR SUPPLY - ELECTRICAL SUPPLY

The hot water cylinder and ancillary pipework, not forming part of the useful heating surface, should be lagged to prevent heat loss and any possible freezing, particularly where pipes run through roof spaces and ventilated under floor spaces.

Draining taps MUST be located in accessible positions, which permit the draining of the whole system, including the boiler and hot water storage vessel.

Draining taps should be at least 1/2 in. nominal size and be in accordance with BS. 2879.

The hydraulic resistances of the boilers, at MAXIMUM OUTPUT with an 11°C (20°F) temperature differential, are shown in Table 9.

ELECTRICAL SUPPLY

Wiring external to the appliance MUST be in accordance with the current I.E.E. Wiring Regulations and any Local Regulations which apply.

The boiler is supplied for 240 V ~ 50 Hz

Single Phase

Fuse Rating is 3 A

The method of connection to the mains electricity supply MUST facilitate complete electrical isolation of the boiler, preferably by the use of a fused, unswitched three pin plug and a shuttered socket outlet, both complying with the requirements of BS. 1363.

Alternatively, a fused double pole switch, having at least a 3 mm (1/8 in.) contact separation in both poles and servicing only the boiler, may be used.

The point of connection to the mains should be readily accessible and adjacent to the boiler, except that for bathroom installations, the point of connection to the mains MUST be situated outside of the bathroom.

Note. Where a room sealed appliance is installed in a room containing a bath or shower then the appliance and any electrical switch or appliance control utilising mains electricity should be so situated that it cannot be touched by a person using the bath or shower.

1 UNPACKING

The boiler is supplied fully assembled in one pack 'A', together with a standard flue assembly for lengths up to 406 mm (16 in.), rear or side flue outlet, in pack 'B'. Optional extras, if ordered. (Programmer Kit, Extension Duct Kit 'D', Vertex Flue Kit and 90° Flue Elbow Kit) are available in separate boxes. Unpack and check the contents.

PACK 'A' CONTENTS Also contained in Pack 'A'; the Hardware Pack (listed opposite), these Installation & Servicing Instructions and the User's Instructions.

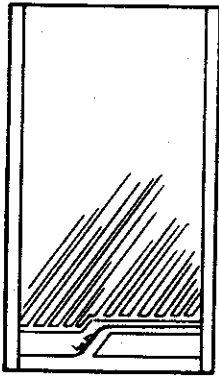

Complete boiler

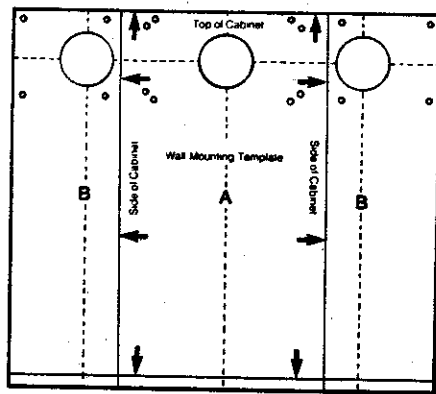

Wall mounting template

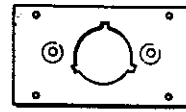

Wall mounting plate

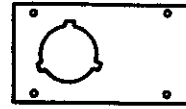

Side outlet terminal mounting plate



Sealing tape

HARDWARE PACK

- Sealing tape for side outlet plate.
- 50 mm x No. 10 wood screw, 13 off.
- Wall plug (TP2B brown), 13 off.
- M6 wing nut, 2 off.
- Data plate indicator arrow, 1 off.
- Sealing discs, 2 off.

PACK 'B' CONTENTS. Also contained in Pack 'B': No. 8 x 6 mm self tappers, 9 off; length of adhesive tape, 1 off; duct cutting support rings, 2 off (cardboard - retain for later use); rectangular washer, 3 off.

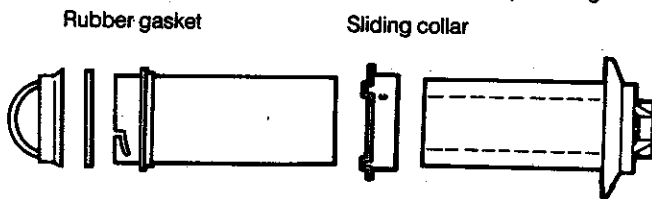

Locking collar

Telescopic air inlet / products outlet assembly

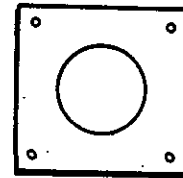

Terminal wall plate

2 BOILER ASSEMBLY - Exploded View

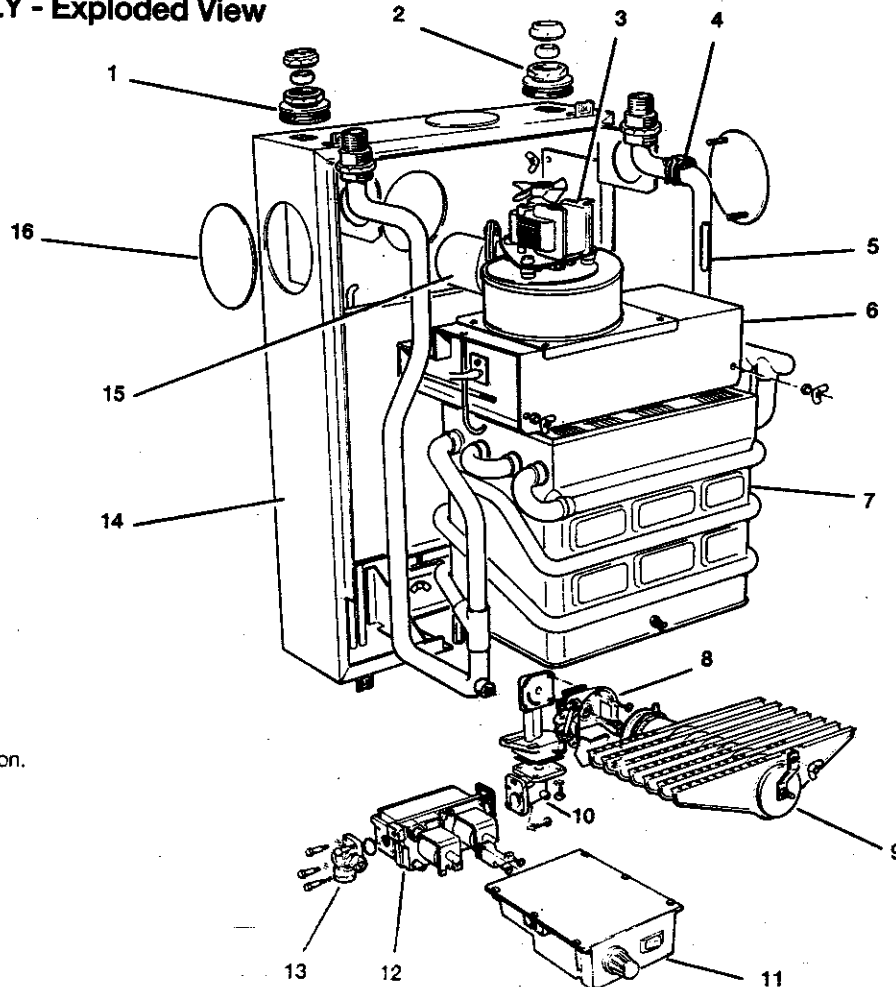

LEGEND

1. Boiler return connection.
2. Boiler flow connection.
3. Fan assembly.
4. Overheat thermostat.
5. Control thermostat pocket.
6. Collector hood.
7. Heat exchanger.
8. Air box and pilot assembly.
9. Main burner.
10. Manifold and manifold extension.
11. Control box.
12. Gas control valve.
13. Gas service cock.
14. Back panel assembly.
15. Flue outlet elbow.
16. Flue outlet sealing plate.

3 WALL MOUNTING AND FLUE LENGTH

IMPORTANT. The boiler **MUST** be installed in a vertical position.

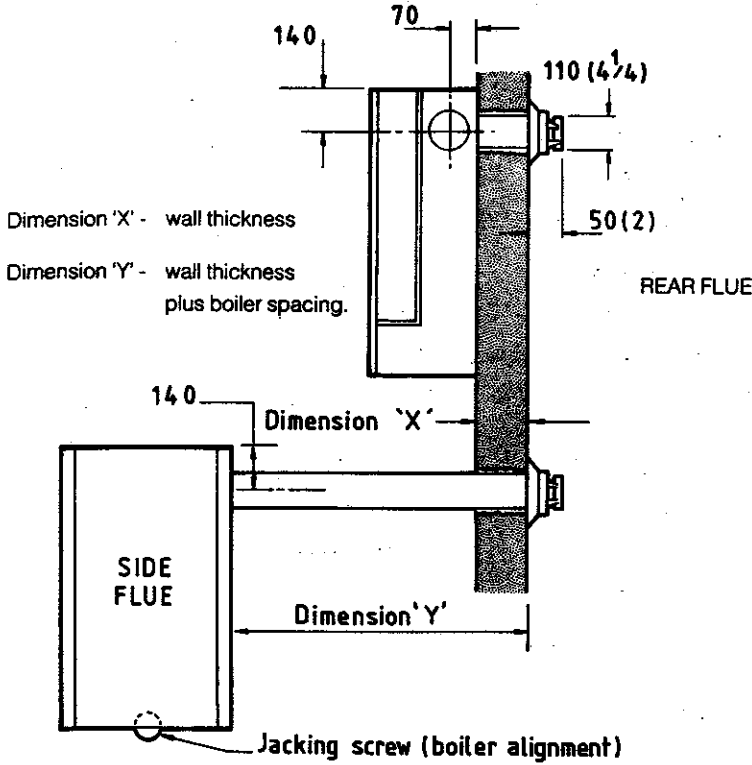

Flue Kits.

- Pack B - supplied as standard.
- Pack D - optional extension kit for side & rear flue outlet. Refer to Frames 27 and 28 (up to 3 lengths).

Flue length, Dimension 'X' or 'Y'	Flue packs required
114 to 216 mm (4 1/2 to 8 1/2 in.)	Pack B, (Cut down as in Frames 9 & 19)
216 to 406 mm (8 1/2 to 16 in.)	Pack B
406 to 1280 mm (16 to 50 3/8 in.)	Pack B (1 off) & Pack D (1 off)
1280 to 2140 mm (50 3/8 to 84 1/4 in.)	Pack B (1 off) & Pack D (2 off)
2140 to 3000 mm (84 1/4 to 118 1/8 in.)	Pack B (1 off) & Pack D (3 off)

4 BOILER DIMENSIONS & CLEARANCES

The following minimum clearances must be maintained for operation and servicing. Additional space will be required for installation depending upon site conditions. In addition a minimum of 450 mm **MUST** be available at the front of the boiler for servicing.

Side and Rear Flue Installations.

1. Provided that the flue hole is cut accurately, e.g. with a core drill the flue can be installed from inside but for flue lengths greater than the width / depth of the boiler then the space in which the boiler is to be installed must be at least equal to the flue length plus the length of the terminal grill, (inside installation up to 610 mm wall thickness only).
2. If a core boring tool is to be used from inside the building, the space in which the boiler is to be installed must be at least wide enough to accommodate the tool.

Side Flue Installations ONLY.

3. Once the boiler has been installed, the clearance on the non-flue side may be reduced to 10 mm.

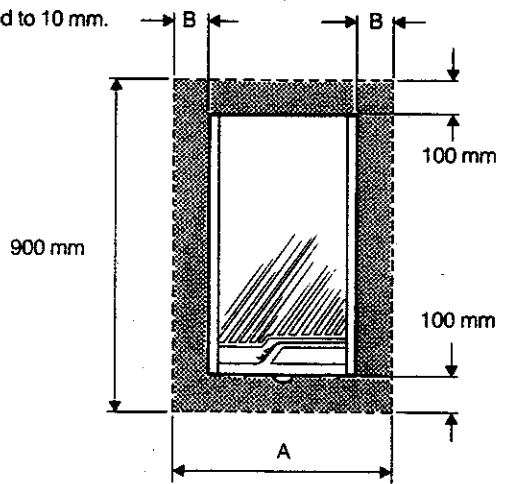

Dimension	NF 230 to NF 260		NF 280	
	Side flue	Rear flue	Side flue	Rear flue
A	425 mm	400 mm	510 mm	485 mm
B	10 mm flue side. 35 mm non flue side.	10 mm both sides.	10 mm flue side. 35 mm non flue side.	10 mm both sides.

5 BOILER CASING REMOVAL

To install the boiler, the casing **MUST** be removed.

1. Release the top captive screw
2. Slide the glass fascia upwards until it locates in the retaining catch.
3. Remove the 2 securing screws, slide the bottom panel forward slightly, & then sideways to remove from the casing.
4. Release the 2 bottom captive screws and lift the casing off the boiler. Place the casing safely to one side, taking care not to damage the glass fascia panel. (Slide the glass panel down in the casing for safe keeping.)

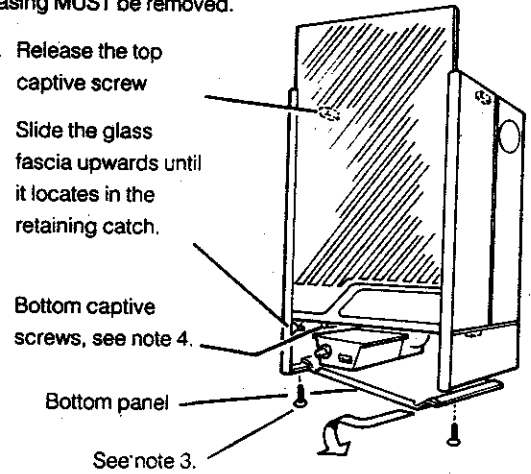

6 FLUE ASSEMBLY - Exploded View

1. An optional duct extension kit is required for wall thicknesses greater than 406 mm (16 in.). Refer to Frames 27 and 28.
2. When cutting the ducts, always use the cardboard support rings provided.

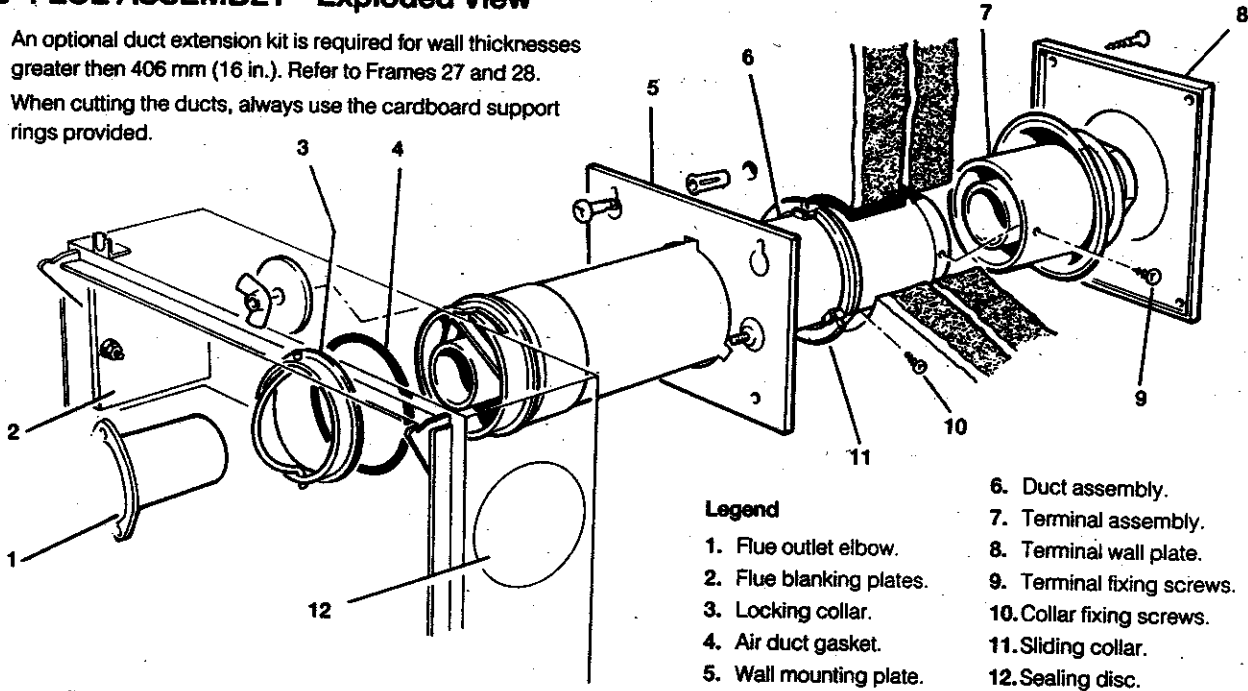

Legend

- | | |
|--------------------------|----------------------------|
| 1. Flue outlet elbow. | 6. Duct assembly. |
| 2. Flue blanking plates. | 7. Terminal assembly. |
| 3. Locking collar. | 8. Terminal wall plate. |
| 4. Air duct gasket. | 9. Terminal fixing screws. |
| 5. Wall mounting plate. | 10. Collar fixing screws. |
| | 11. Sliding collar. |
| | 12. Sealing disc. |

7 WALL MOUNTING TEMPLATE

1. Discard both sections 'B' of the template.
2. Tape the template into the selected position.
3. Ensure squareness by hanging a plumb line as shown.
4. Mark onto the wall the 4 mounting plate screw positions and the lower fixing screw positions.
5. Mark onto the wall the position of the flue duct.
Note. Mark the centre of the hole as well as the circumference.
6. Remove the template from the wall.

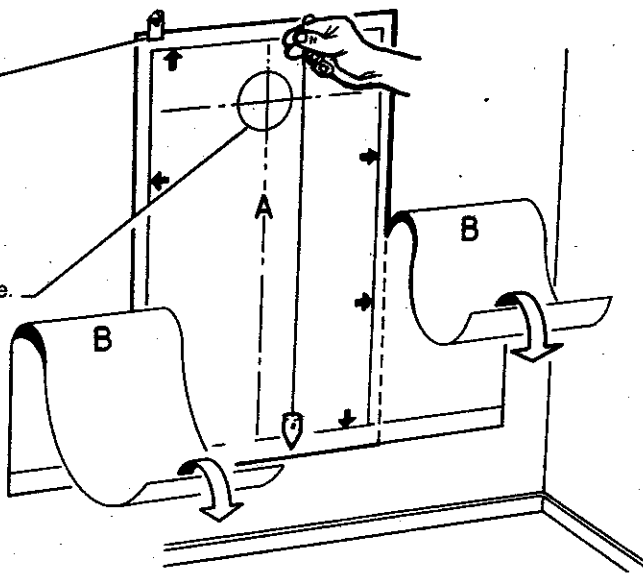

8 PREPARING THE WALL

IMPORTANT. Ensure that, during the cutting operation, masonry falling outside of the building does not cause damage or personal injury.

1. Cut the flue hole (preferably with a 5 in. core boring tool) ensuring that the hole is square to the wall. If the hole has been quite accurately cut with a drill, then making good the wall faces is not essential- as seals are provided at both ends of the flue. However, both wall faces immediately around the cut hole should be flat; make good if necessary. For less accurate holes make good to approximately 125 mm diameter at the two wall faces. If the flue hole is longer than 610 mm this must be done from the outside for the outer face, as access to outside is needed to fit the terminal plate anyway.

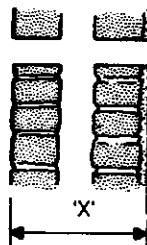

SECTION SHOWING WALL THICKNESS, 'X'.

Note. Check all of the hole positions BEFORE drilling.

5 in. diameter flue hole

Note. If the terminal is to be sited within 25 to 40 mm of a corner or vertical pipe (refer to Table 3.) then the hole MUST be accurately cut and the rubber weather seal trimmed around the groove provided. The terminal wall plate need not be fitted.

2. Measure and note the wall thickness 'X'.
3. Drill the 5 fixing holes with an 8 mm (5/16 in.) masonry drill.
4. Insert the plastic plugs provided.
5. Locate two No. 10 x 2 in. screws in the wall mounting plate top fixing holes and screw home to within 6 mm (1/4 in.) of the wall sur face.

REAR FLUE OUTLET ONLY

REAR FLUE OUTLET ONLY

9 CUTTING THE DUCT ASSEMBLY

WALL THICKNESSES OF 114 TO 216 mm ONLY.

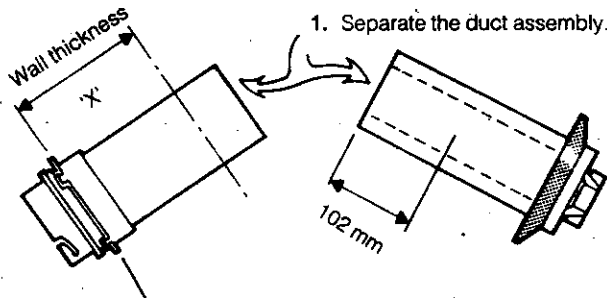

1. Separate the duct assembly.
2. Push the sliding collar to the end of the duct and measure off dimension 'X' (wall thickness).
3. Cut to length 'X', using the cardboard duct rings for support. **Note.** Cut the inner flue tube 6mm (1/4 in.) longer than the outer air tubes.
4. Always cut 102 mm (4 in.) off the terminal section.
5. Remove the cardboard support rings.
6. Re-assemble the terminal, aligning the seams.

11 FITTING THE FLUE ASSEMBLY

FROM EITHER THE INSIDE OR OUTSIDE OF THE BUILDING.

1. Push the assembly through the wall.
2. Locate the wall mounting plate over the flue assembly. Engage the flue duct collar lugs with the wall mounting plate slots & rotate the flue assembly to lock. Proceed to Frame 12.

Weather seal. Apply soap solution to ease fitting.

FROM OUTSIDE OF THE BUILDING.

1. Fit the wall mounting plate (Frame 12)- but do not drive the No. 10 screws home.
2. Push the assembly through the wall. Engage the collar lugs with the wall mounting plate slots & rotate the flue assembly to lock.
3. Drive home the No. 10 wall mounting plate screws.

PROCEED NOW TO STEP 3 OF FRAME 12

12 WALL MOUNTING PLATE

1. Engage the plate on the top fixing screws.

Flue is shown locked in position.

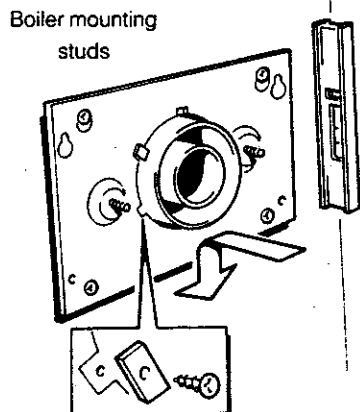

2. Locate two No. 10 x 2 in. wood screws in the remaining fixing holes and drive home all four screws.
3. Check with a spirit level that the plate is vertical.

3. Align the holes in the sliding collar flange with the 3 cut-outs in the wall plate. Insert 3 of the self-tappers and rectangular washers to retain the assembly.

10 JOINING THE DUCT ASSEMBLY

WALL THICKNESSES UP TO 406 mm ONLY.

1. Push the sliding collar to the boiler end of the assembly.
2. Set the assembly to length, wall thickness 'X' plus 50 mm (2 in.).

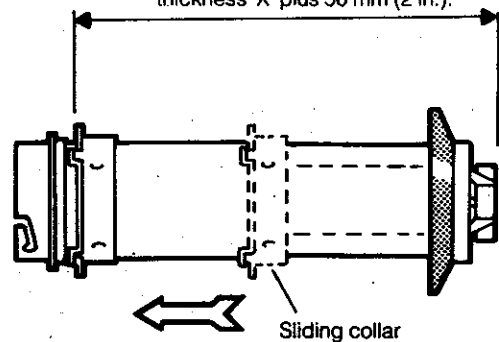

3. Using the sliding collar as a template at the duct join, mark the positions of the 3 fixing screws. **Note.** If the duct join is too close to the rubber weather seal to permit access for drilling, mark the hole positions at the mid-point of the duct.
4. Slide the collar back to the boiler end of the duct and mark the positions for a further 3 fixing screws.

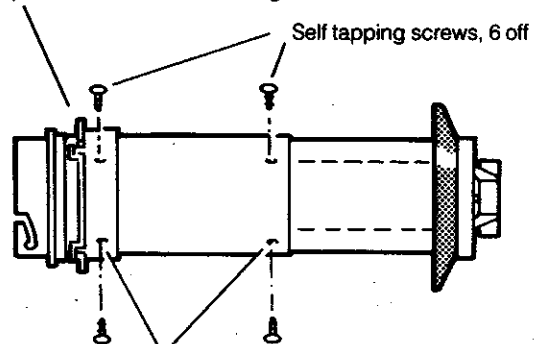

5. Drill the 6 fixing holes using a 3.2 mm. drill. Insert the self tapping screws in order to fix the collar in position and lock the duct assembly. **DO NOT DRILL THE INNER FLUE DUCT.**
6. Seal the air duct joint with the aluminium tape provided in the Hardware Pack.

FOR WALL THICKNESSES ABOVE 406 mm, REFER TO FRAMES 27 & 28 - FLUE EXTENSION DUCTS.

13 TERMINAL WALL PLATE

This plate is provided to allow the neat concealment and full compression of the rubber seal. If the flue hole and flue ducts have been accurately cut and the outside wall face is flat then its use is not essential *except that this plate must be used on wall thicknesses over 610 mm (24 in.)*.

1. Position the terminal wall plate over the terminal.
2. Drill 4 fixing holes with an 8 mm (5/16 in.) masonry drill.
3. Insert the four plastic plugs provided.
4. Secure the plate with four of the No. 10 x 2in. screws provided.

Note. If the terminal is less than 2 m (6.6 ft.) above ground level, an approved terminal guard should be fitted. Refer to Page 4.

14 MOUNTING THE BOILER

1. Disconnect the pressure sensing tube from the fan.
2. Disconnect the fan electrical leads and unclip the harness from the fan mounting plate.
3. Remove the four screws, each with two washers, securing the fan assembly to the top of the collector hood.
4. Lift off the fan assembly and place carefully to one side.
5. Remove the flue pipe connector from its transit position and discard it (for use with side flue only).

Note. Always take care when handling the fan, to preserve the balance of the impeller.

UPPER VIEW OF BOILER ASSEMBLY See note 1.

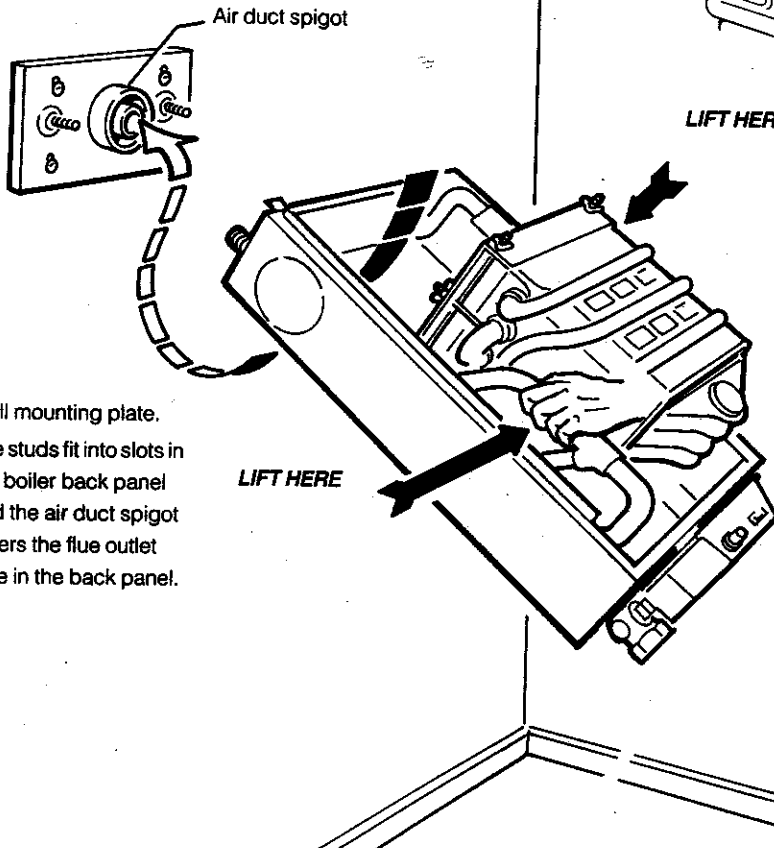
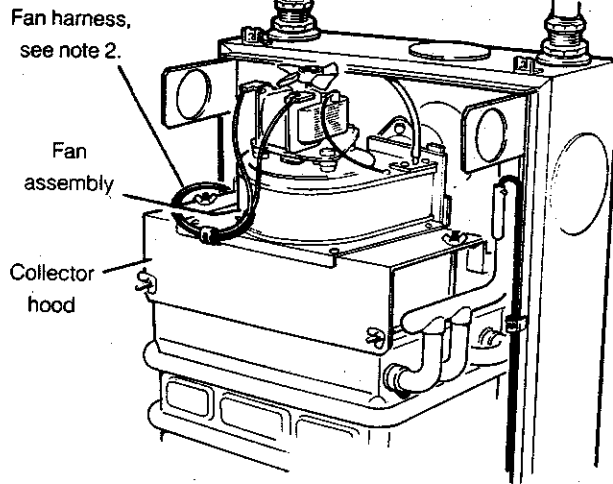

Wall mounting plate.
The studs fit into slots in the boiler back panel and the air duct spigot enters the flue outlet hole in the back panel.

Have ready to hand the sealing discs and wing nuts supplied in the Hardware Pack.

6. Lift the boiler onto the wall mounting plate - as shown.
7. Fit a sealing disc over each stud and secure with a wing nut.
Note. Before fully tightening the wing nuts, check the boiler alignment using a spirit level, and adjust as necessary with the jacking screw. Refer to Frame 3.
8. Locate the No. 10 x 2 in. screw in the boiler lower fixing hole on the jacking screw and secure to the wall.

DO NOT USE THE BURNER / CONTROLS ASSEMBLY FOR LIFTING.

15 SEALING THE BOILER AND FLUE

1. Stretch the rubber gasket over the air duct spigot.
2. Fit the locking collar as shown and rotate it to engage with the locking slots in the flue assembly.
3. Fold the locking handle as shown.
4. Slacken the two nuts at joint 'B-B' on the fan outlet elbow.
5. Refit the fan plate assembly, fully engaging the fan outlet spigot into the flue pipe.
6. Secure the fan assembly to the collector hood with the four screws previously removed.

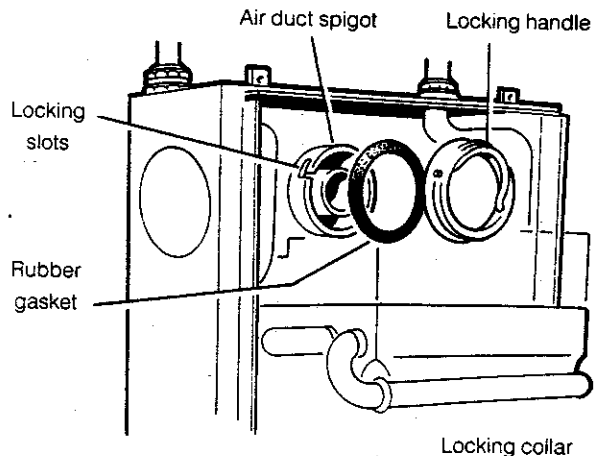
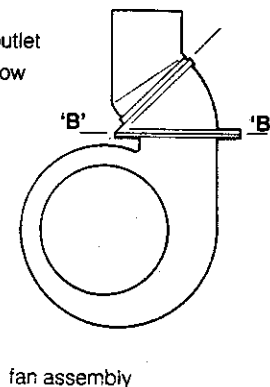

7. Retighten the two extended nuts at joint 'B-B'.
8. Reconnect the electrical leads and the pressure sensing tube to the fan.

REAR FLUE OUTLET ONLY

SIDE FLUE CONNECTOR

16 FLUE ASSEMBLY - Exploded View

1. An optional duct extension kit is required for lengths of dimension 'Y' (wall thickness plus boiler / wall spacing) greater than 406 mm (16 in.). Refer to Frames 3 and 27.
2. When cutting the ducts, always use the cardboard support rings provided.

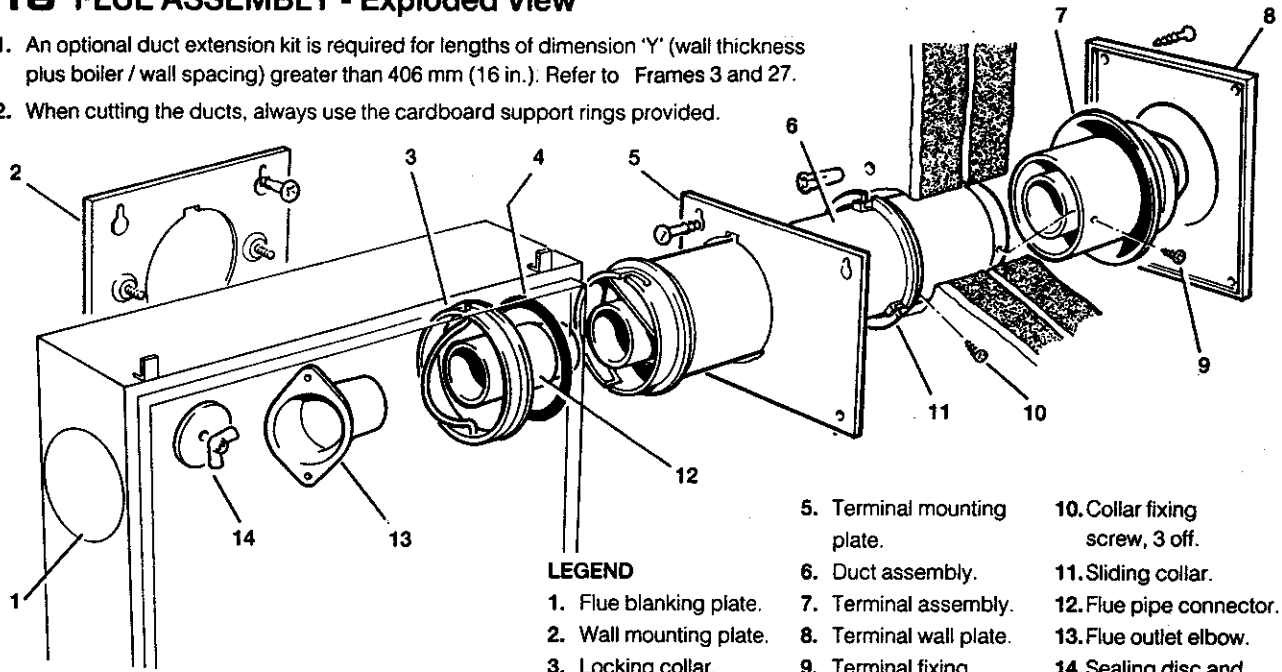

LEGEND

- | | | |
|-------------------------|----------------------------------|--|
| 1. Flue blanking plate. | 7. Terminal assembly. | 10. Collar fixing screw, 3 off. |
| 2. Wall mounting plate. | 8. Terminal wall plate. | 11. Sliding collar. |
| 3. Locking collar. | 9. Terminal fixing screw, 3 off. | 12. Flue pipe connector. |
| 4. Air duct gasket. | | 13. Flue outlet elbow. |
| | | 14. Sealing disc and wing nut. (2 off) |

17 WALL MOUNTING TEMPLATE

1. Separate the templates.
2. Tape both templates into the selected position locating template 'B' via an extended centre line as shown.
3. Ensure squareness by hanging a plumbline as shown.
4. Mark onto the wall the mounting plate screw positions and the lower fixing screw position.
5. Mark onto the wall the 4 terminal mounting plate screw positions.
6. Mark onto the wall the position of the flue duct hole.

Note. Mark the centre of the hole as well as the circumference.
7. Remove both templates from the wall.

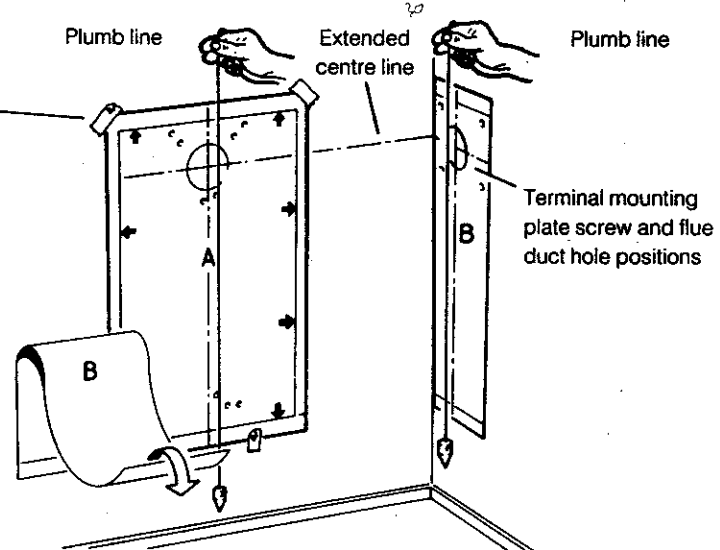

18 PREPARING THE WALL

IMPORTANT. Ensure that, during the cutting operation, masonry falling outside of the building does not cause damage or, personal injury.

1. Cut the flue hole (preferably using a 5 in. core boring tool), ensuring that the hole is square to the wall. If the hole has been quite accurately cut with a drill then making good the wall faces is not essential - as seals are provided at both ends of the flue. However, both wall faces immediately around the cut hole should be flat; make good if necessary. For less accurate holes make good to approximately 125 mm diameter at the two wall faces. For holes longer than 610 mm this must be done from outside for the outer face- as access to outside is needed to fit the terminal wall plate anyway.
2. Measure the wall thickness 'X' and calculate dimension 'Y' (i.e. Boiler spacing plus 'X'). Refer to Frame 3.
3. Drill the all 9 fixing holes with an 8 mm (5/16 in.) masonry drill and insert the plastic plugs provided.
4. Locate two No. 10 x 2 in. screws in the terminal mounting plate top fixing holes and screw home to within 6mm (1/4 in.) of wall surface.

Note. If the terminal is to be sited 25 to 40 mm from a corner or vertical pipe (refer to Table 3) the hole must be accurately cut and the rubber weather seal trimmed around the groove provided. The terminal wall plate need not be fitted.

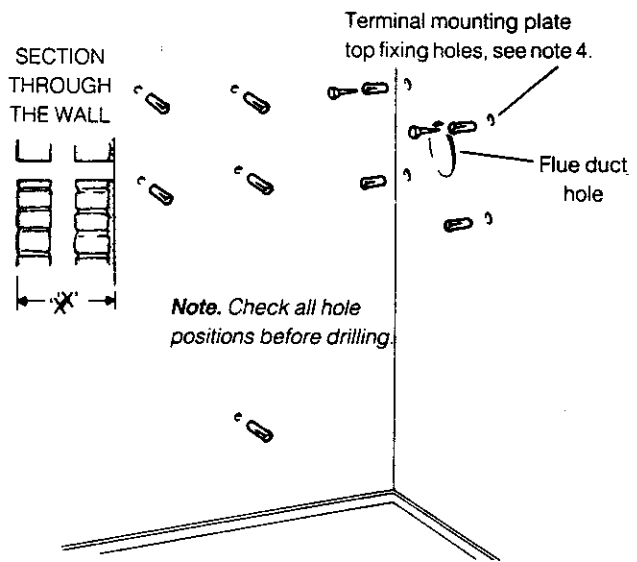

19 CUTTING THE DUCT ASSEMBLY
FLUE LENGTHS OF 114 TO 216 mm ONLY.

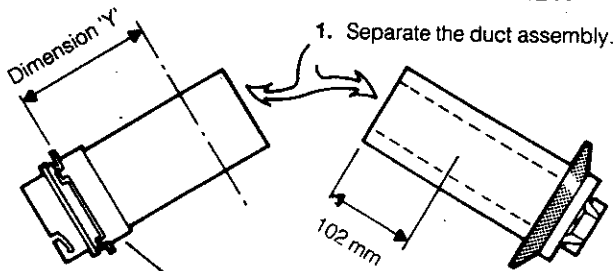

1. Separate the duct assembly.
2. Push the sliding collar to the end of the duct and measure off dimension 'Y' (wall thickness plus boiler spacing).
3. Cut to length 'Y', using the cardboard duct rings for support. **Note.** Cut the inner flue tube 6 mm (1/4 in.) longer than the outer air tubes.
4. Always cut 102 mm (4 in.) off the terminal section.
5. Remove the cardboard support rings.
6. Re-assemble the terminal, aligning the seams.

21 FITTING THE FLUE ASSEMBLY
FROM INSIDE OF THE BUILDING.

1. Push the flue duct assembly through the wall.
2. Take the terminal mounting plate and stick the sealing tape provided to the reverse side of the plate. Locate the plate over the projecting flue duct assembly and engage the flue duct collar lugs with the terminal mounting plate slots. Rotate the flue assembly to lock. Continue the installation procedure from Note 2 of Frame 22.

Weather seal. Apply soap solution to ease fitting.

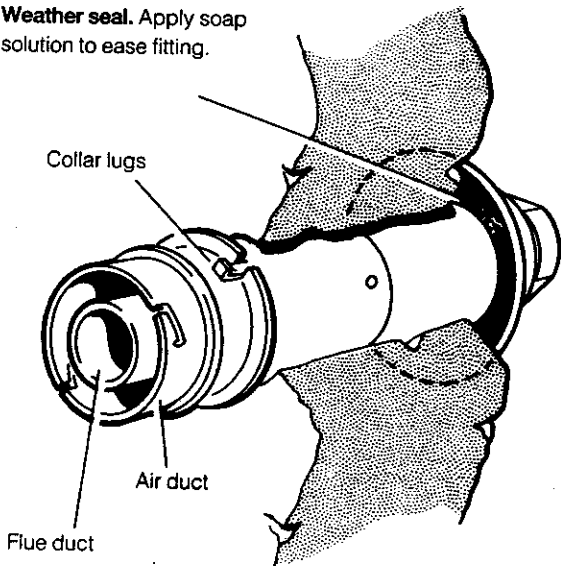

FROM OUTSIDE OF THE BUILDING ONLY.

1. Fit the terminal mounting plate as detailed in Notes 1 to 4 of Frame 22 - but do not drive the No. 10 x 2 in. fixing screws fully home until the flue duct assembly is engaged.
2. From outside of the building, push the assembly through the wall. Engage the flue duct collar lugs with the terminal mounting plate slots and rotate the flue assembly to lock.
3. Drive home the No. 10 x 2 in. fixing screws.
5. Make good between the plate and the corner of the wall.
6. Align the holes in the sliding collar flange with the 3 slots in the terminal wall plate. Insert 3 of the self tapping screws and rectangular washers, provided, to retain the assembly. Refer to the detail in Frame 22.

20 JOINING THE DUCT ASSEMBLY
FLUE LENGTHS UP TO 406 mm ONLY.

1. Push the sliding collar to the boiler end of the assembly.
2. Set the assembly to length, dimension 'Y' plus 50 mm (2 in.).

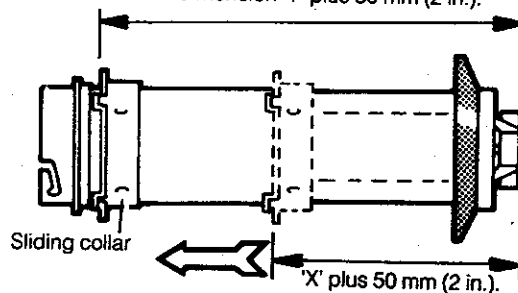

3. Using the sliding collar as a template at the duct joint, mark the positions of the 3 fixing screws (A). **Note.** If the duct joint is too close to the rubber weather seal to permit access for drilling, mark the hole positions at the mid-point of the duct.
4. Set the collar to the required position, i.e. dimension 'X' (wall thickness) plus 50 mm (2 in.) and mark the positions for a further 3 fixing screws (B).

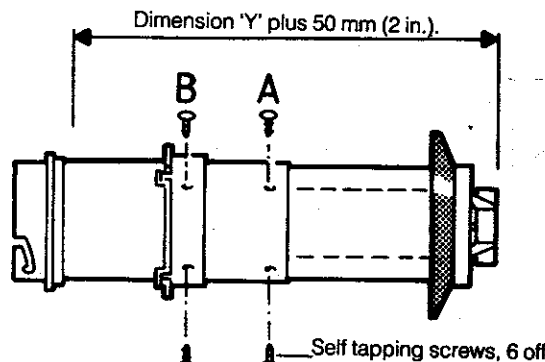

5. Drill the 6 fixing holes using a 3.2 mm. drill. Insert the self tapping screws in order to fix the collar in position and lock the duct assembly. **DO NOT DRILL THE INNER FLUE DUCT.** **Note.** If the duct locking screws restrict the sliding collar then use the collar locking screws to lock the whole assembly.
6. Seal the air duct joint with the aluminium tape provided in the Hardware Pack.

FOR FLUE LENGTHS ABOVE 406 mm, REFER TO FRAMES 27 & 28 - FLUE EXTENSION DUCTS.

22 TERMINAL MOUNTING PLATE

1. Stick the sealing tape, provided, to the reverse side of the plate.
2. Engage the plate on the top two fixing screws.
3. Locate two No. 10 x 2 in. screws in the bottom fixing holes and drive home all four screws.

The flue assembly is shown locked in position.

4. Check with a spirit level that the plate is vertical.
5. Make good between the plate and the corner of the wall.
6. Align the holes in the sliding collar flange with the 3 cut outs in the wall plate. Insert 3 of the self tapping screws and rectangular washers, provided, to retain the flue assembly.

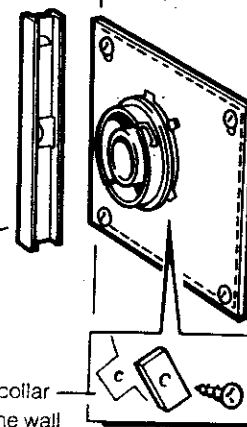

PIPE FLUE COLLAR ONLY

SIDE FLUE OUTLET ONLY

23 WALL MOUNTING PLATE

1. Locate two No. 10 x 2 in. screws in the plate top fixing holes and screw home to within 6 mm (1/4 in.) of the wall surface.
2. Engage the plate on the top two fixing screws.

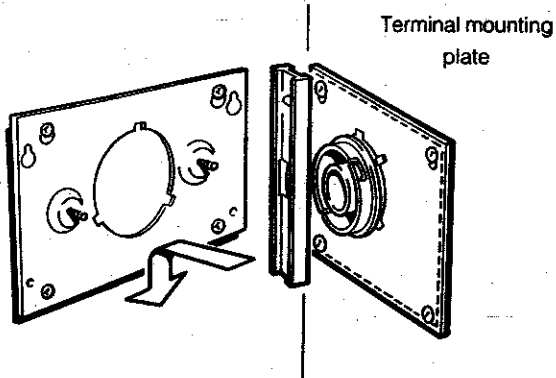

3. Locate two No. 10 x 2 in. screws in the bottom fixing holes and drive home all four screws.
4. Check with a spirit level that the plate is vertical.

24 TERMINAL WALL PLATE

This plate allows the neat concealment and full compression of the rubber seal. Its use is not essential if the flue hole and flue ducts have been accurately cut and the outside wall face is flat *except that this plate must be used on wall thickness over 610 mm (24 in.)*.

1. Position the terminal wall plate over the terminal.
2. Drill 4 fixing holes with an 8 mm (5/16 in.) masonry drill.
3. Insert the four plastic plugs provided.
4. Secure the plate with four of the No. 10 x 2 in. screws provided.

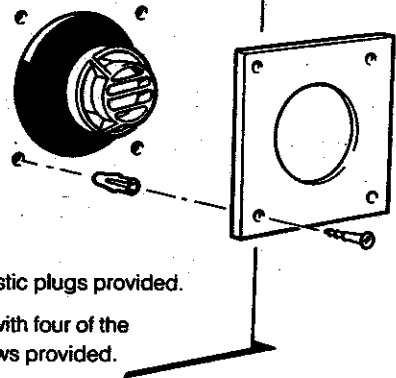

Note. If the terminal is less than 2 m (6.6 ft.) above ground level, an approved terminal guard should be fitted. Refer to Page 4.

25 MOUNTING THE BOILER

1. Disconnect the pressure sensing tube from the fan.
2. Disconnect the fan electrical leads and unclip the harness from the fan mounting plate.
3. Remove the four screws, each with two washers, securing the fan assembly to the top of the collector hood.
4. Lift off the fan assembly and place carefully to one side.
5. Remove the flue pipe connector from its transit position.
6. Remove the blanking plate and disc from the appropriate side of the boiler and transfer them to the rear.

Note. Always take care when handling the fan, to preserve the balance of the impeller.

UPPER VIEW OF BOILER ASSEMBLY

See note 1.

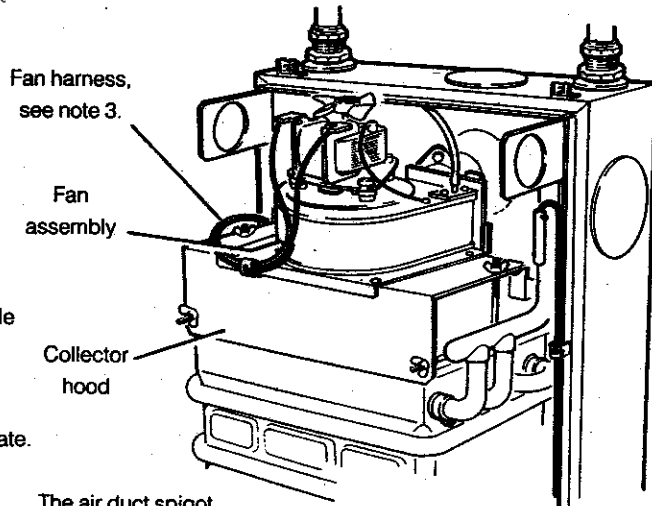

Have ready to hand sealing discs and wing nuts supplied in the Hardware Pack.

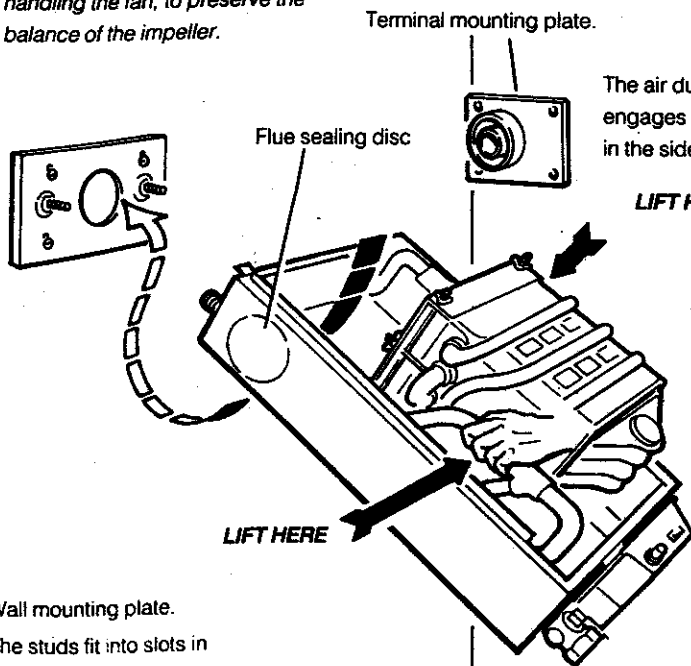

Wall mounting plate.
The studs fit into slots in the boiler back panel.

7. Lift the boiler onto the wall mounting plate as shown.
8. Slide the boiler sideways into its intended position, centring the studs in the slots and engaging the air duct spigot in the hole in the side panel.
9. Fit a sealing disc over each stud and secure with a wing nut.
Note. Before fully tightening the wing nuts, check the boiler alignment using a spirit level and adjust as necessary with the jacking screws. Refer to Frame 3.
10. Locate a No. 10 x 2 in. screw in the boiler lower fixing hole, on the jacking screw, and secure to the wall.

DO NOT USE THE BURNER / CONTROLS ASSEMBLY FOR LIFTING

26 SEALING THE BOILER AND FLUE / REFITTING THE FAN ASSEMBLY

1. Sealing the Boiler and Flue.

- (a) Stretch the rubber gasket over the air duct spigot.
- (b) Fit the collar as shown and rotate to engage with the flue assembly locking slots.
- (c) Fold the locking handle as shown.

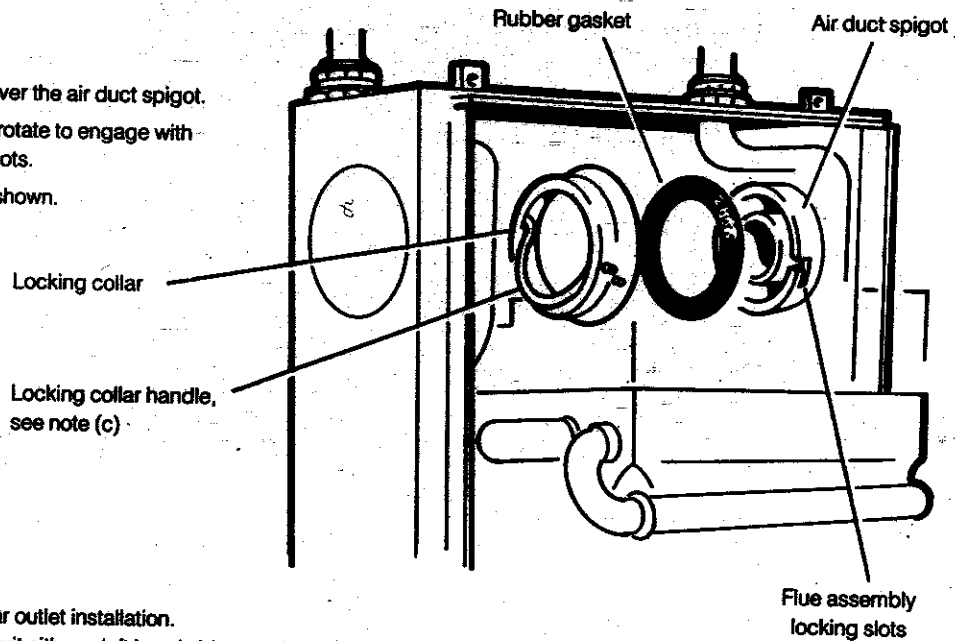

2. Fan Outlet Arrangement.

The fan outlet is supplied for rear outlet installation. Re-arrange the outlet elbow to suit either a left hand side or a right hand side outlet as shown below.

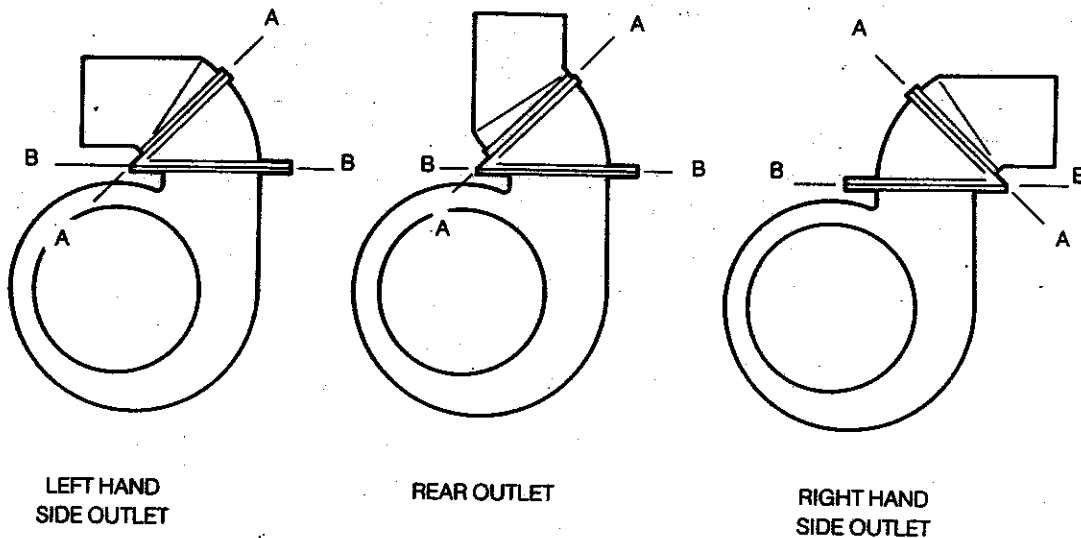

Note. When altering the arrangement of the fan outlet elbow, for either side, slacken the extended nuts at joint 'B - B' to help alignment when re-fitting the fan assembly.

LEFT HAND SIDE OUTLET: Disconnect at joint 'A - A' and rotate through 180°

RIGHT HAND SIDE OUTLET: Disconnect at joint 'A - A', 'B - B' & rotate both halves through 180°

3. Fan Assembly Refitting.

- (a) Cut the side outlet flue pipe connector to the required length, given in the Table below.

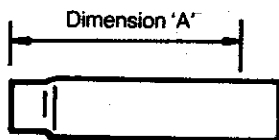

Boiler size	Dimension 'A'	
	Left hand flue	Right hand flue
NF 23Q to NF 260	No cutting required	105 mm (4 1/8 in.)
NF 280	200 mm (8 in.)	145 mm (5 3/4 in.)

- (b) Fit the flue pipe connector onto the fan outlet elbow.
- (c) Refit the fan assembly onto the collector hood, fully engaging the flue pipe connector into the flue pipe. Secure the assembly with the four screws previously removed. Re-tighten the extended nuts at joint 'B - B' on the flue outlet elbow.
- (d) Reconnect the electrical leads and the pressure sensing tube to the fan.

PROCEED TO FRAME 29

27 PACK 'D' CONTENTS AND GENERAL ARRANGEMENT OF THE FLUE DUCTS

PACK 'D' FLUE EXTENSION DUCT KIT CONTENTS. Unpack the Kit and check the contents.

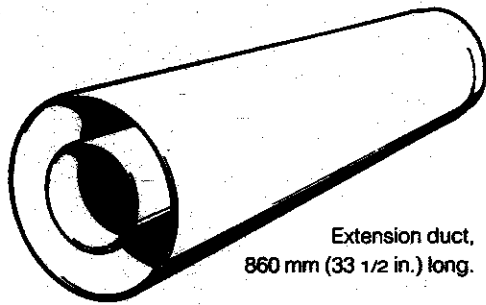

No. 8 x 1/4 in. self tapping screws, 4 off.



FLUE LENGTHS UP TO 3 m. USE A MAXIMUM OF THREE KITS ONLY.

GENERAL ARRANGEMENT. Note. Side flue configuration shown.

1. A MAXIMUM OF THREE KITS ONLY may be used together.
2. Always cut the extension ducts at the plain ends only.
3. Ensure that there is at least a 25 mm (1 in.) overlap at each joint.
4. For flue lengths of less than 457 mm (18 in.), ensure that the collar is positioned on an air duct (outer).
5. Flue extensions of greater length than 1 m (39 in.) should be supported with the bracket provided.
6. Tape all air duct connections.
7. Always align the seams when re-assembling the ducts.

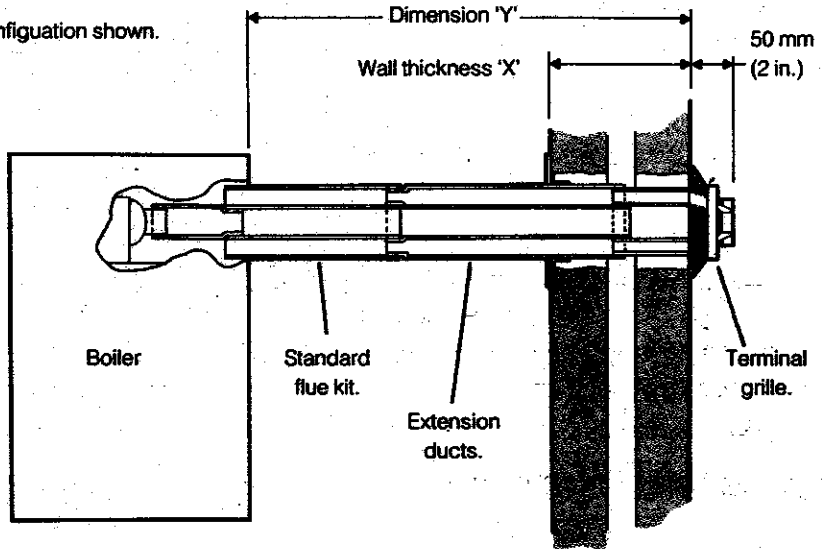

28 FITTING THE KIT

IMPORTANT. Read in conjunction with Frame 27.

1. Separate the Flue duct assembly.
2. Insert the appropriate extension duct(s) with the plain end(s) toward the terminal.
3. Re-assemble the terminal and the duct assemblies.
4. Push the sliding collar back to the boiler end of the duct, or to its intended position.
5. Set the assembly to length, i.e. Dimension 'X' (wall thickness) plus 50 mm (2 in.) or Dimension 'Y' (wall thickness and boiler spacing) plus 50 mm (2 in.).

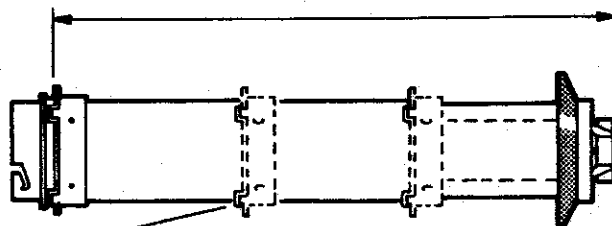

6. Using the sliding collar as a template at the joints of any ducts mark the positions the fixing screws (3 screws for each joint).

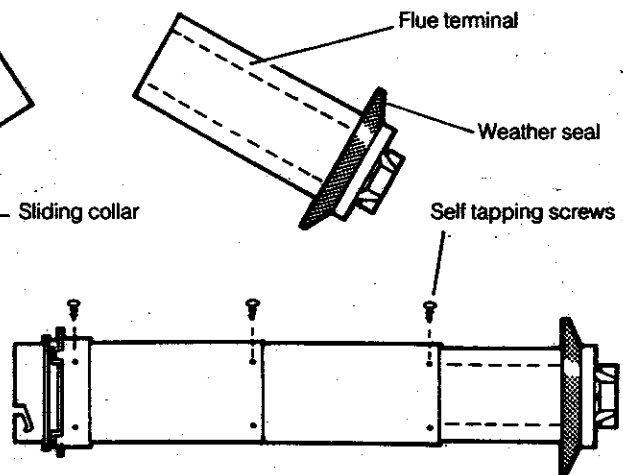

7. Drill at the markings with a 3.2 mm. drill.
8. Lock the assembly in position with the self tapping screws provided.
9. Drill through the holes of the collar into the air duct with a 3.2 mm. drill and lock the sliding collar into position with 3 of the self tapping screws provided.

Note. If the flue duct assembly locking screws restrict the sliding collar then use the collar locking screws to lock the whole assembly.

REAR & SIDE FLUE OUTLET

29 GAS CONNECTION

1. A **MINIMUM** working gas pressure of 20 mbar (8 in.wg) **MUST** be available at the boiler inlet.
2. Extend a gas supply pipe **NOT LESS THAN 15 mm O.D.** to the boiler and connect to the gas service cock situated at the bottom left hand side of the boiler.
 Note. If the pipe run from the meter to the boiler is greater than 3 m (10 ft.), it is recommended that 22 mm O.D. pipe is used.

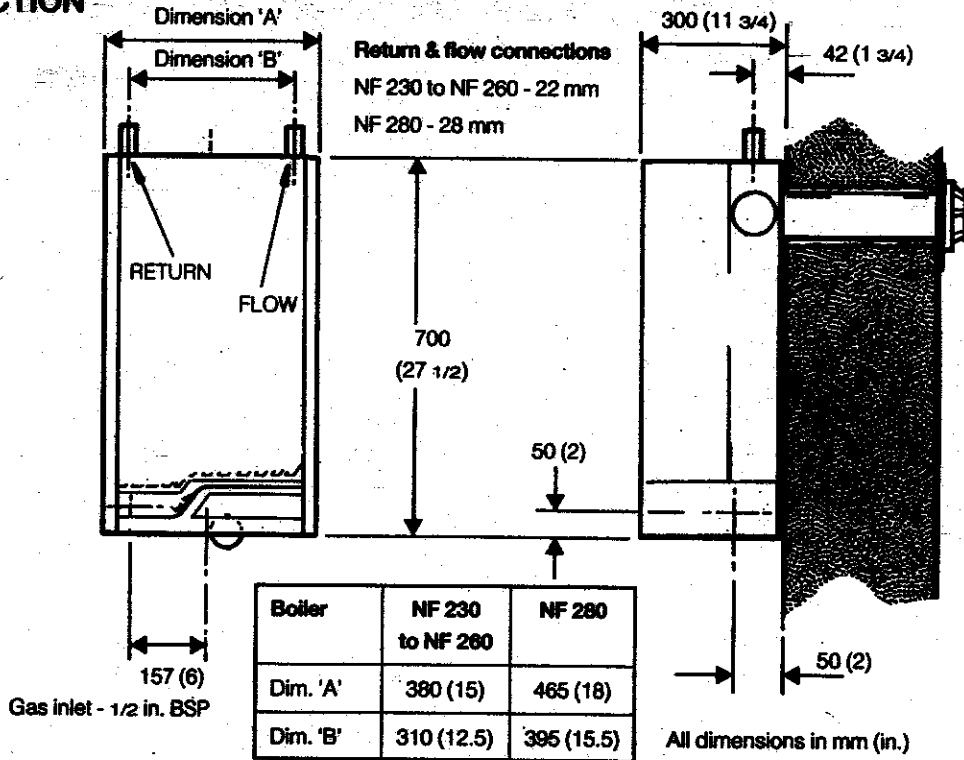

3. To facilitate connection, it is recommended that the gas service cock is not removed from the gas control valve. A 1/2 in. BSP x 15 mm connector prefitted with a short stub connection should be screwed into the cock using a suitable sealant. Ensure that the gas supply pipe does not foul the boiler casing when fitted.

IMPORTANT. The gas service cock contains a non-metallic seal, so must not be overheated when making capillary connections.

4. Test the gas installation for soundness and purge in accordance with BS. 6891.

30 WATER CONNECTIONS

1. Connect the system flow and return pipework to the two water connections at the top of the boiler.

Note. When the required output exceeds 16.1kW (55 000 Btu/h) 28mm (1in.) flow and return pipes should be used, both to and from the boiler. On the NF 260 boiler only connect to the boiler in 22mm (7/8in.) pipe and increase to 28 mm (1in.) as soon as is practicable.

2. Ensure that all valves are open, fill and vent the system and check for water soundness. Note:- This appliance is **NOT** suitable for use with a direct hot water cylinder.

IDEAL ELAN NF 280 ONLY

When venting the heat exchanger using the manual air vent on the flow header, protect the electrical controls with a waterproof sheet or similar.

31 OPEN VENT SYSTEM REQUIREMENTS

The system should be vented directly off the boiler **FLOW** pipe, as close to the boiler as possible. The cold feed entry should be inverted and **MUST** be positioned between the pump and the vent, and not more than 150 mm (6 in.) away from the vent connection.

Note. Combined feed and vent pipes may also be fitted.

There should be a minimum height - 450 mm (18 in.) of open vent above the cistern water level. If this is not possible then refer to Frame 32. The vertical distance between the highest point of the system and the feed / expansion cistern water level **MUST** not be less than 450mm (18 in.) The pump must be fitted on the flow side of the boiler.

A suitable pump is a domestic circulator capable of providing an 11°C (20°F) temperature differential (e.g. Grundfos UPS 15/50 or equivalent). The vertical distance between the pump and the feed / expansion cistern **MUST** comply with the pump Manufacturer's minimum requirements to avoid cavitation. Should these conditions not apply, either lower the pump position or raise the cistern above the minimum requirement specified by Caradon Heating Ltd. Isolation valve should be fitted as close to the pump as possible.

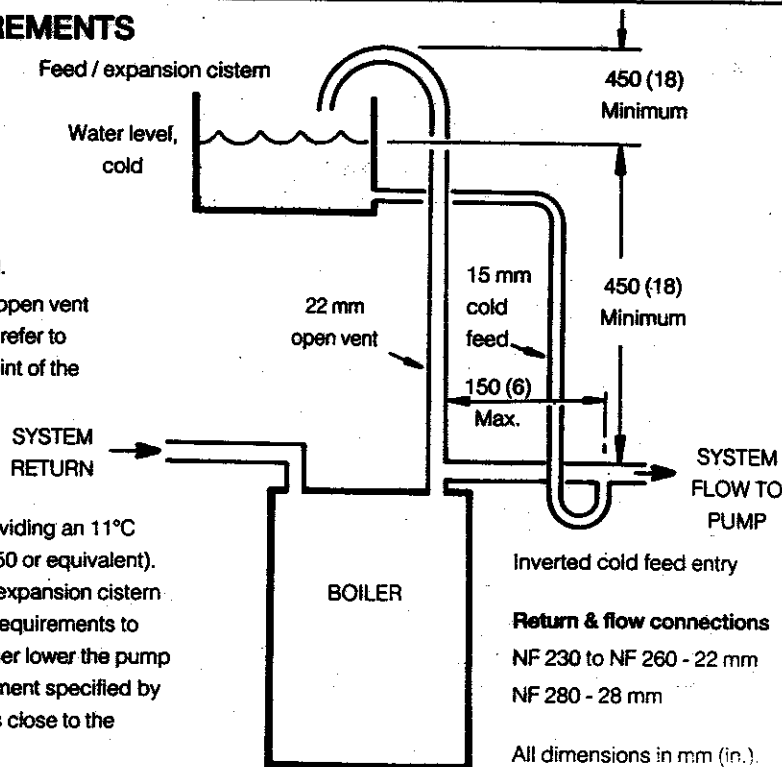

32 LOW HEAD INSTALLATIONS - OPEN VENT

The ideal Elan 2 NF range of boilers can be installed in low head situations by fitting a surge arrester in the expansion pipe.

The following conditions **MUST** be observed.

1. The surge arrester must be at least 42 mm diameter x 150 mm long.
 2. The cistern water level must be at least 200 mm above the highest point of the system.
 3. The height of water in the surge arrester must be at least 75 mm.
 4. The vent connection must **NOT** be made directly off the top of the boiler.
- Note.** The pump manufacturer's minimum requirements must be complied with.

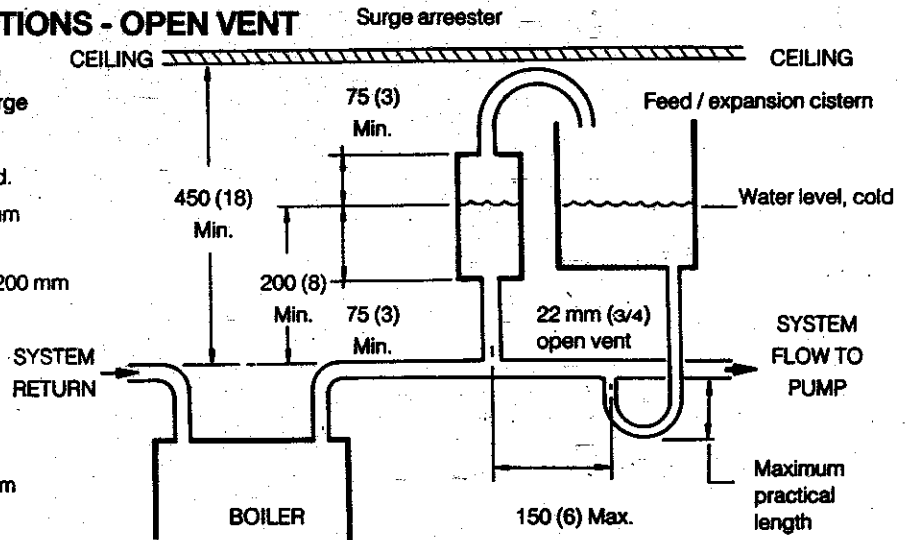

33 SCHEMATIC PIPEWORK AND BY-PASS ADJUSTMENT - OPEN VENT

WATER FLOW RATE AND PRESSURE LOSS

Boiler size		NF 230	NF 240	NF 250	NF 260	NF 280
Boiler output	kW (Btu/h)	8.8 (30 000)	11.7 (40 000)	14.7 (50 000)	17.6 (60 000)	23.4 (80 000)
Water flow rate for 11°C differential	l/min. (gal./h)	11.4 (150)	15.2 (200)	19.0 (250)	22.8 (300)	30.3 (400)
Pressure loss for 11°C differential	mbar (in.w.g)	27 (11)	45 (18)	70 (28)	102 (41)	92 (37)
Water flow rate for 9°C differential	l/min. (gal./h)	13.8 (183)	18.5 (244)	23.2 (306)	27.8 (367)	37.0 (488)
Pressure loss for 9°C differential	mbar (in.w.g)	40 (16.4)	67 (26.9)	105 (41.8)	152 (61.2)	138 (55)

1. The temperature differential across the boiler **MUST NOT** be more than 11°C.
 2. When the NF 260 (with output above 16.1kW [55 000 Btu/h]) and NF 280 units are used, 28mm (1in.) flow and return pipes **MUST** be used - both to and from the boiler.
 3. The control system with the boiler **MUST** provide a load in circuit with the boiler of at least 10% of the boiler output whenever the boiler fires. In order to achieve this load it may be necessary to provide 'uncontrolled' radiator(s) which cannot be manually turned off by the user.
 4. A by-pass **MUST** be fitted as far from the boiler as possible, consisting of the following:
 - (a) 15 mm pipe not more than 1 metre long for boilers up to 50 000 Btu/h output.
 - (b) 22 mm pipe for boilers of over 60 000 Btu/h output.
- The by-pass should incorporate a balancing valve which **CANNOT** be adjusted by the householder.
5. The circulating pump used should have adequate performance to give a maximum temperature differential across the boiler of 9°C when the by-pass & the 'uncontrolled' radiator(s) (when fitted) are closed, with either the heating or the domestic hot water controls calling for heat.

BY-PASS ADJUSTMENT

6. With the heating circuit **OPEN** and the by-pass and 'uncontrolled' radiator(s) (if fitted) **CLOSED**, set the pump to give a maximum of 9°C differential across the boiler and system. The system should be at full temperature for this operation and this is a convenient point to balance the system flows.
7. Open the valve on the 'uncontrolled' radiator(s) (if fitted) and set its temperature differential to approximately 10°C.
8. Open the by-pass until the differential across the boiler is 11°C.
9. Check that the water flow through the boiler is adequate when the heating controls are satisfied and the domestic hot water controls are calling for heat.

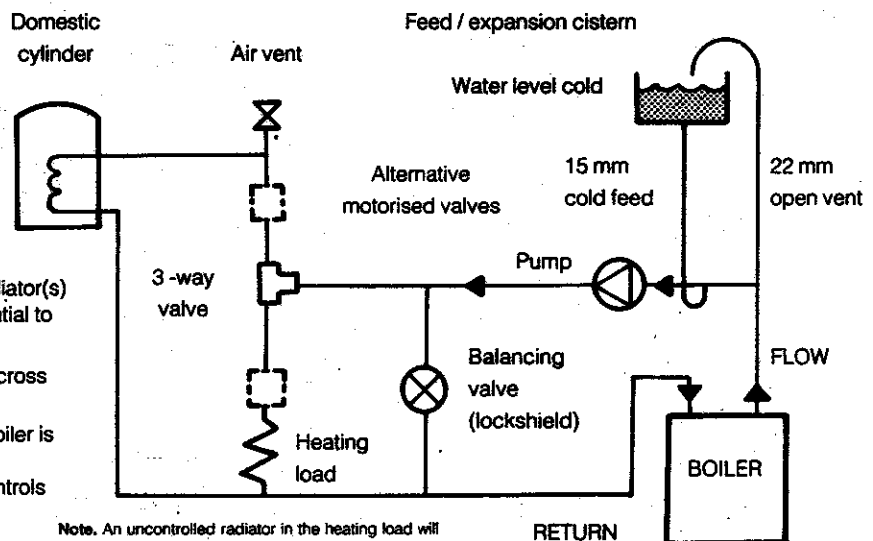

Note. An uncontrolled radiator in the heating load will only emit heat when the zone valve for heating is open.

Thermostatic Radiator Valves

Caradon Heating Ltd. support the recommendations made in BS. 5449 and by leading manufacturers of domestic heating controls that heating systems utilising the full thermostatic radiator valve control of temperature in individual rooms should also be fitted with a room thermostat controlling the temperature in a space served by radiators not fitted with such a valve.

Such an arrangement will provide for a potentially more efficient control of the environment and will also avoid the continuous running of the circulation pump during programmed heating 'ON' periods - thus saving electrical energy. It is therefore strongly recommended that, when thermostatic radiator valves are used, space heating temperature control over a living / dining area or a hallway having a heating requirement of at least 10% of the boiler heat output is achieved using a room thermostat whilst other rooms are individually controlled by thermostatic radiator valves. If a room thermostat is not fitted as described above then it is recommended that the system includes one uncontrolled radiator to give a minimum heat loss of 10% of the boiler heat output under design conditions.

34 SEALED SYSTEM REQUIREMENTS

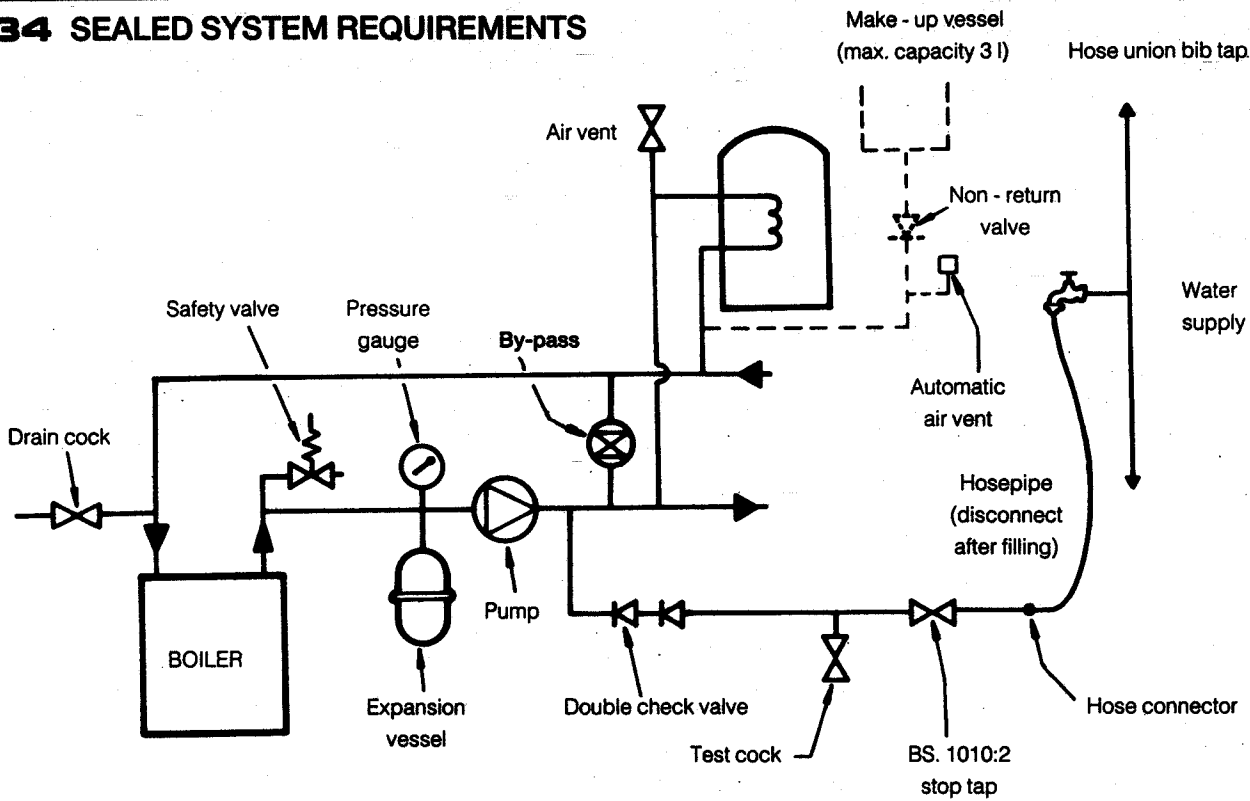

Notes.

- A. Any connection for filling or replenishing of a sealed primary circuit from a supply pipe is conditional upon a water undertaker seeking and obtaining consent for a relaxation of its Byelaws 38.8 (1), from the Secretary of State.
- B. The method of filling, re-filling, topping up or flushing sealed primary hot water circuits from the mains via a temporary hose connection is only allowed if acceptable to the Local Water Authority.

1. General.

- (a) The installation must comply with the requirements of BS. 6798 and BS. 5449.
- (b) The installation should be designed to work with flow temperatures of up to 82° C.
- (c) All components of the system, including the heat exchanger of the indirect cylinder, must be suitable for a working pressure of 3 bar (45 lb.ft. / in²) and temperature of 110° C. Care should be taken in making all connections so that the risk of leakage is minimised.

2. Safety Valve.

A spring loaded safety valve complying with the relevant requirements of BS. 6759 must be fitted in the flow pipe as close to the boiler as possible and with no intervening valve or restriction. The valve should have the following features:

- (a) A non-adjustable pre-set lift pressure not exceeding 3 bar (45 lb.ft. / in²).
- (b) A manual testing device.
- (c) Provision for connection of a discharge pipe.

The valve or discharge pipe should be positioned such that the discharge of water or steam cannot create a hazard to the occupants of the premises, or cause damage to electrical components and wiring.

3. Pressure Gauge.

A pressure gauge covering at least the range 0 - 4 bar (0 - 60 lb.ft. / in²) must be fitted to the system. The gauge should be easily seen from the fitting point and should preferably be connected at the same point as the expansion vessel.

4. Expansion Vessel.

- (a) A diaphragm type expansion vessel must be connected at a point close to the inlet side of the pump, the connecting pipe being not less than 15 mm (1/2 in. nominal) size and not incorporating valves of any sort.
- (b) The vessel capacity must be adequate to accept the expansion of the system water when heated to 110° C (230° F).
- (c) The charge pressure must not be less than the static water head above the vessel. The pressure attained in the system when heated to 110° C (230° F) should be at least 0.35 bar (5 lb.ft. / in²) less than the lift pressure of the safety valve. For guidance on vessel sizing refer to the Table in Frame 35. For further details refer to BS. 5449, BS. 7074:1 & the British Gas Corporation publication - 'Material and Installation Specifications for Domestic Central Heating & Hot Water'.

5. Cylinder.

The cylinder must be either of the indirect coil type or a direct cylinder fitted with an immersion calorifier, which is suitable for operating on a gauge pressure of 0.35 bar (5 lb.ft. / in²) in excess of the safety valve setting. Single feed indirect cylinders are not suitable for sealed systems.

6. Make-up Water.

Provision must be made for replacing water loss from the system either,

- (a) From a manually filled make-up vessel with a readily visible water level. The vessel should be mounted at least 150 mm (6 in.) above the highest point of the system, and be connected through a non-return valve to the system, fitted at least 300 mm (12 in.) below the make-up vessel on the return side of the domestic hot water cylinder or radiators.
- (b) Where access to a make-up vessel would be difficult, by pre-pressurisation of the system. Refer to 'Filling'.

7. Mains Connection.

There must be no direct connection to the mains water supply or to the water storage tank supplying domestic water, even through a non-return valve, without the approval of the Local Water Authority.

35 SEALED SYSTEM REQUIREMENTS

8. Filling.

The system may be filled by one of the following methods:

(a) Through a cistern, used for no other purposes, via a ball valve permanently connected directly to a service pipe and / or a cold water distributing pipe.

The static head available from the cistern should be adequate to provide the desired initial system design pressure. The cold feed pipe from the cistern should include a non-return valve & a stop valve with an automatic air vent connected between them, the stop valve being located between the system & the automatic air vent. The stop valve may remain open during normal operation of the system if automatic water make-up is required.

(b) Through a self-contained unit comprising a cistern, pressure booster pump if required, and if necessary, an automatic pressure reducing valve and flow restrictor. The cistern should be supplied through a temporary connection from a service pipe or cold water distributing pipe.

This unit may remain permanently connected to the heating system to provide limited automatic water make-up. Where the temporary connection is supplied from a service pipe or distributing pipe which also supplies other 'draw-off' points at a lower level then a double check valve shall be installed upstream of the draw off point.

Sizing procedure for expansion vessels: The volume of the expansion vessel (litres) fitted to a sealed system shall not be less than that given by the table below multiplied by a factor of 0.8 (for flow temperatures of less than 88° C).

(c) Through a temporary hose connection from a draw off tap supplied from a service pipe under mains pressure. Where the mains pressure is excessive a pressure reducing valve shall be used to facilitate filling.

The following fittings shall form a permanent part of the system and shall be fitted in the order stated.

A stop valve complying with the requirements of BS. 1010 Part 2 (the hose from the draw off tap shall be connected to this fitting).

A test cock.

A double check valve of an approved type.

- Thoroughly flush out the whole of the system with cold water without the pump in position.
- With the pump fitted, fill & vent the system until the pressure gauge registers 1.5 bar (21.5 lb.ft. / in²), Examine for leaks.
- Check the operation of the safety valve by manually raising the water pressure until the valve lifts. This should occur within ± 0.3 bar (± 4.3 lb.ft. / in²) of the pre-set lift pressure.
- Release water from the system until the initial system design pressure is reached.
- Light the boiler and heat the system to the maximum working temperature. Examine for leaks.
- Turn off the boiler and drain the system while still hot.
- Refill and vent the system.
- Adjust the initial pressure to the required value.

Safety valve setting	3.0 bar			3.5 bar			3.5 bar		
	0.5 bar	1.0 bar	1.5 bar	0.5 bar	1.0 bar	1.5 bar	0.5 bar	1.0 bar	
Vessel charge and initial system pressure									
Total water content of system	Expansion vessel volume (litres)								
25 (litres)	2.1	2.7	3.9	2.3	3.3	5.9	2.8	5.0	
50	4.2	5.4	7.8	4.7	6.7	11.8	5.6	10.0	
75	6.3	8.2	11.7	7.0	10.0	17.7	8.4	15.0	
100	8.3	10.9	15.6	9.4	13.4	23.7	11.3	20.0	
125	10.4	13.6	19.5	11.7	16.7	29.6	14.1	25.0	
150	12.5	16.3	23.4	14.1	20.1	35.5	16.9	30.0	
175	14.6	19.1	27.3	16.4	23.4	41.4	19.7	35.0	
200	16.7	21.8	31.2	18.8	26.8	47.4	22.6	40.0	
225	18.7	24.5	35.1	21.1	30.1	53.3	25.4	45.0	
250	20.8	27.2	39.0	23.5	33.5	59.2	28.2	50.0	
275	22.9	30.0	42.9	25.8	36.8	65.1	31.0	55.0	
300	25.0	32.7	46.8	28.2	40.2	71.1	33.9	60.0	
Multiplying factors for other system volumes	0.0833	0.109	0.156	0.094	0.134	0.237	0.113	0.20	

36 ELECTRICAL CONNECTIONS

WARNING. This appliance **MUST** be efficiently earthed.

A mains supply of 240V ~ 50 Hz is required.

All external controls & wiring **MUST** be suitable for mains voltage. Wiring should be 3-core PVC insulated cable, **NOT LESS** than 0.75 mm² (24 x 0.2 mm) and to BS. 6500, Table 16. Wiring external to the boiler **MUST** be in accordance with the current I.E.E. Wiring Regulations and any Local Regulations.

The supply connection may be made via a removable plug to an unswitched shuttered socket/ outlet, preferably adjacent to the boiler, & should such a plug be used for connection to the mains, it must be of the 3-pin type-wired as shown, fused at 3A & comply with the requirements of BS. 1363. Alternatively, a fused double-pole switch, having a 3mm contact separation in both poles, serving only the boiler & its external controls may be used.

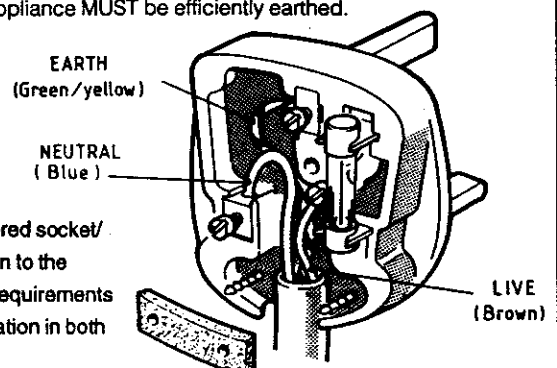

37 INTERNAL WIRING

Note. If the Programmer Kit is to be fitted, refer to the instructions provided with the kit & Frame 38.

A Pictorial Wiring diagram is shown in Frame 39 & a wiring diagram is included in the Lighting Instructions label on the casing bottom panel.

1. Remove the 2 control box lid fixing screws and disengage the lid retention hooks. Remove the lid.
2. Route the mains cable through the strain relief mounted on the pressure switch bracket.
3. Lift the terminal strip from its control box retention slots.
4. Wire the live, neutral and earth into the terminal strip, ensuring that the lengths of the current carrying conductors are shorter than the earth conductor - so that if the cable slips in its anchorage the current carrying conductors become taut before the earth conductor.
5. Slide the terminal strip back into its retention slot and push the cable into the control box R.H. side rear cable clamp.
6. Tighten the main cable relief on the pressure switch bracket.
7. Replace the control box lid and retain with the 2 screws previously removed. Note. Ensure that no basic insulation is accessible outside of the control box.

INCOMING MAINS WIRING DETAIL

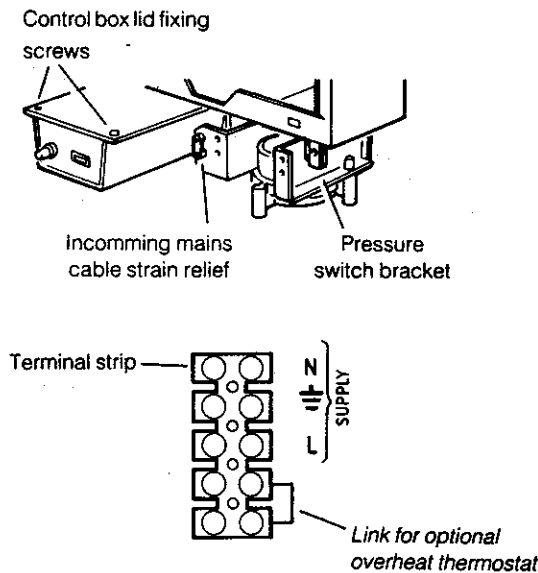

FLOW WIRING DIAGRAM

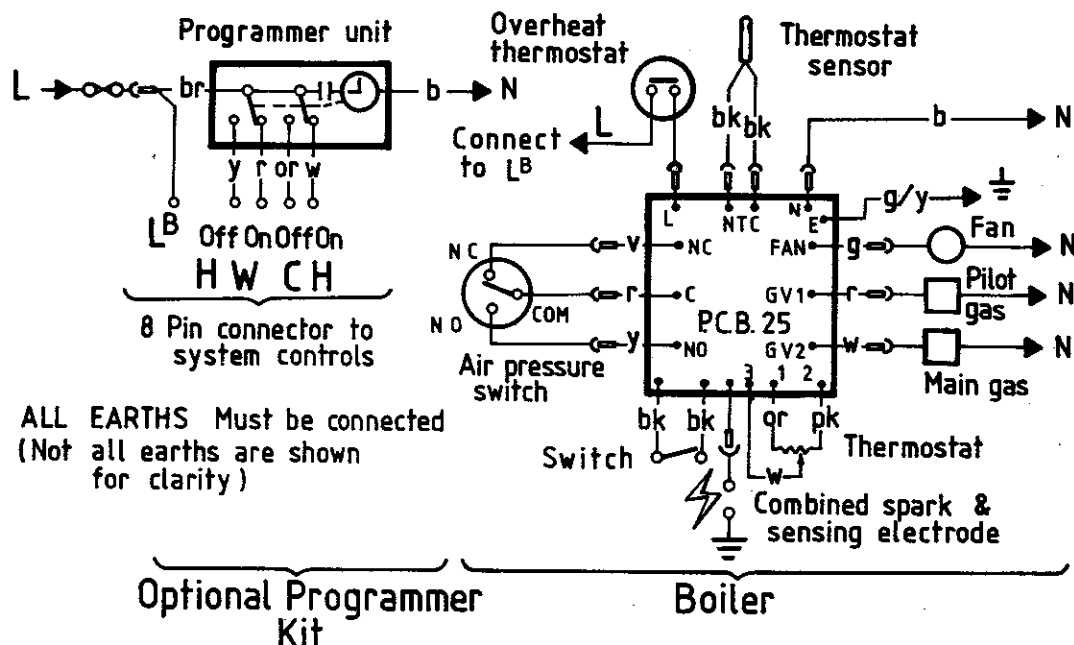

ALL EARTHS Must be connected (Not all earths are shown for clarity)

LEGEND

- b blue
- bk black
- br brown
- r red
- y yellow
- w white
- g/y green / yellow
- g grey
- or orange
- v violet
- pk pink

38 EXTERNAL WIRING

External wiring MUST be in accordance with the current I.E.E. Wiring Regulations.

The wiring diagrams illustrated in Frames 40 to 42 cover the systems most likely to be used with this appliance.

For wiring external controls to the Ideal Elan 2 NF boiler, reference should be made to the systems wiring diagram supplied by the relevant Manufacturer in conjunction with the wiring diagrams shown in Frame 39.

Difficulty in wiring should not arise, providing the following directions are observed:

1. Controls that switch the system ON & OFF, e.g. a time switch, MUST be wired in series, in the live mains lead to the boiler.
2. Controls that over-ride an ON / OFF control, e.g. a frost thermostat, MUST be wired into the mains lead in parallel with the controls to be over-riden. Refer to Frame 43.

3. If a proprietary system is used, follow the instructions supplied by the Manufacturers.
4. The pump must always be wired in 'parallel' with the boiler.
5. SYSTEM DESIGNS FEATURING CONTROLS OR WIRING ARRANGEMENTS WHICH ALLOW THE BOILER TO FIRE WHEN THERE IS NO PUMPED CIRCULATION TAKING PLACE SHOULD NOT BE FITTED.

Advice on required modifications to wiring may be obtained from the component Manufacturers.

Notes.

1. Connections between a frost thermostat and the time control should be made without disturbing other wiring.
2. A frost thermostat should be sited in a cool place in the house, but where it can sense heat from the system.

39 PICTORIAL WIRING

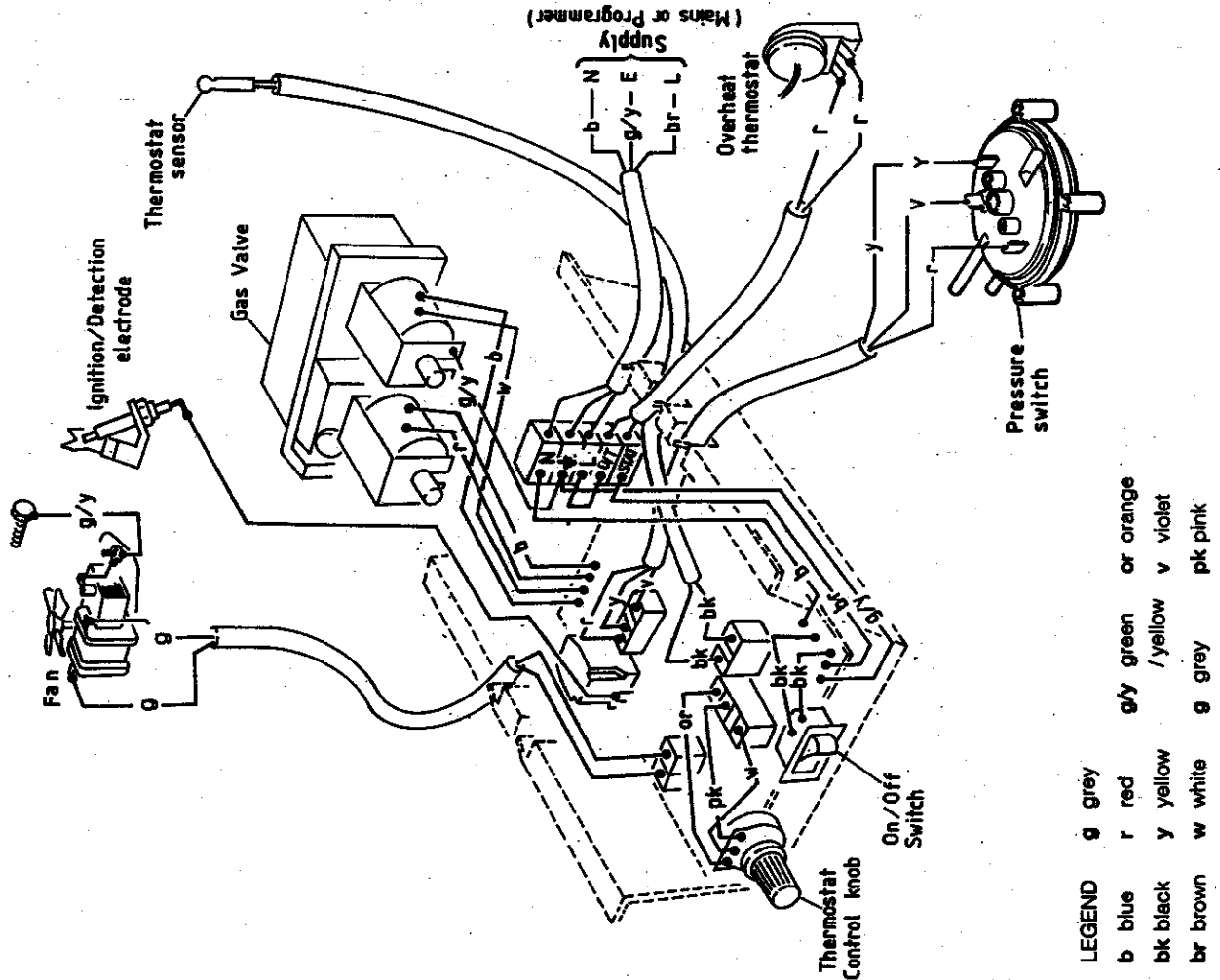

- LEGEND**
- g grey
 - b blue
 - r red
 - y yellow
 - w white
 - g/y green or orange
 - /yellow v violet
 - g grey
 - pk pink

40 MID POSITION VALVE - Pumped only

- Some earth wires are omitted for clarity. Ensure proper earth continuity when wiring.
- This is a fully controlled system - set the boiler thermostat to HIGH.
- Numbering of thermostat terminals applies ONLY to the Manufacturer mentioned.
- Switchmaster Midi operates similarly, but the wiring is not identical - see the manufacturer's wiring diagram.

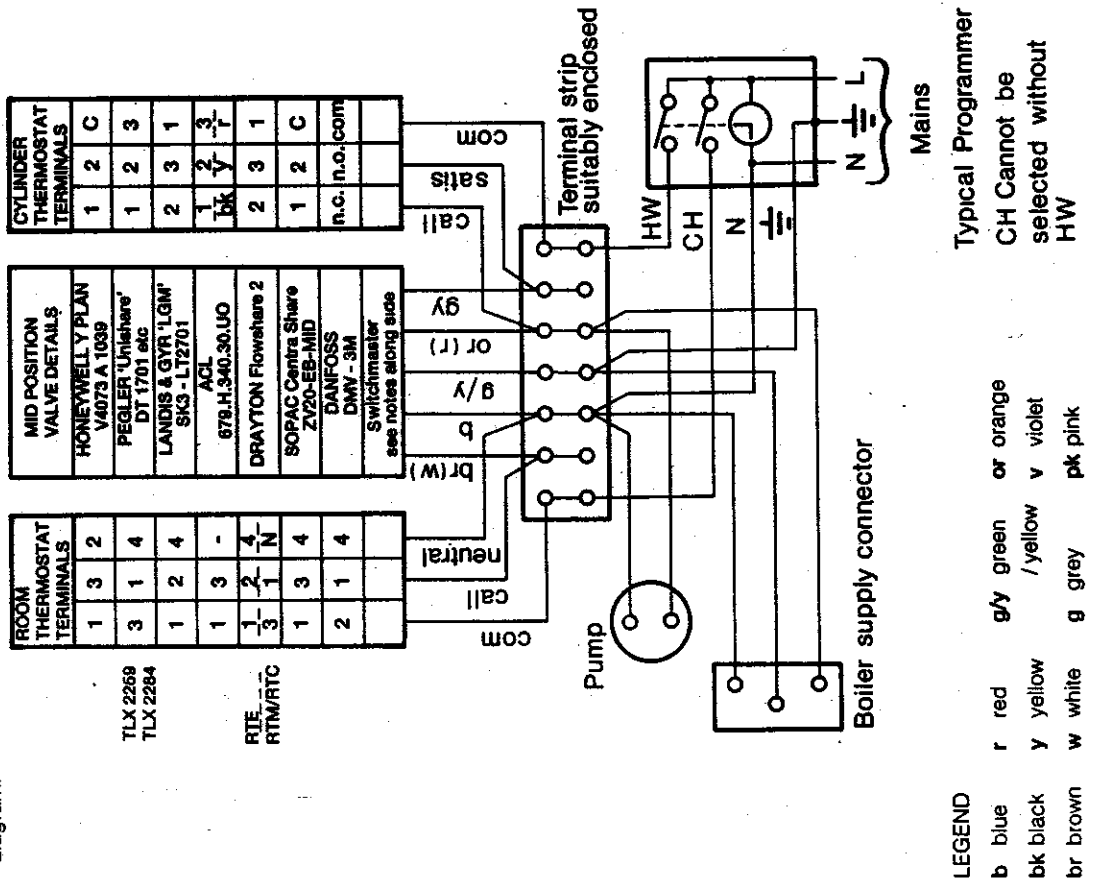

42 TWO SPRING CLOSED VALVES - Pumped only

1. Some earth wires are omitted for clarity. Ensure proper earth continuity when wiring.
2. This is a fully controlled system - set the boiler thermostat to HIGH.
3. Numbering of thermostat terminals applies ONLY to the Manufacturer mentioned.
4. Switchmaster Autozone also has grey and orange wires, but the GREY (not the orange) wire must be connected to the incoming live supply.

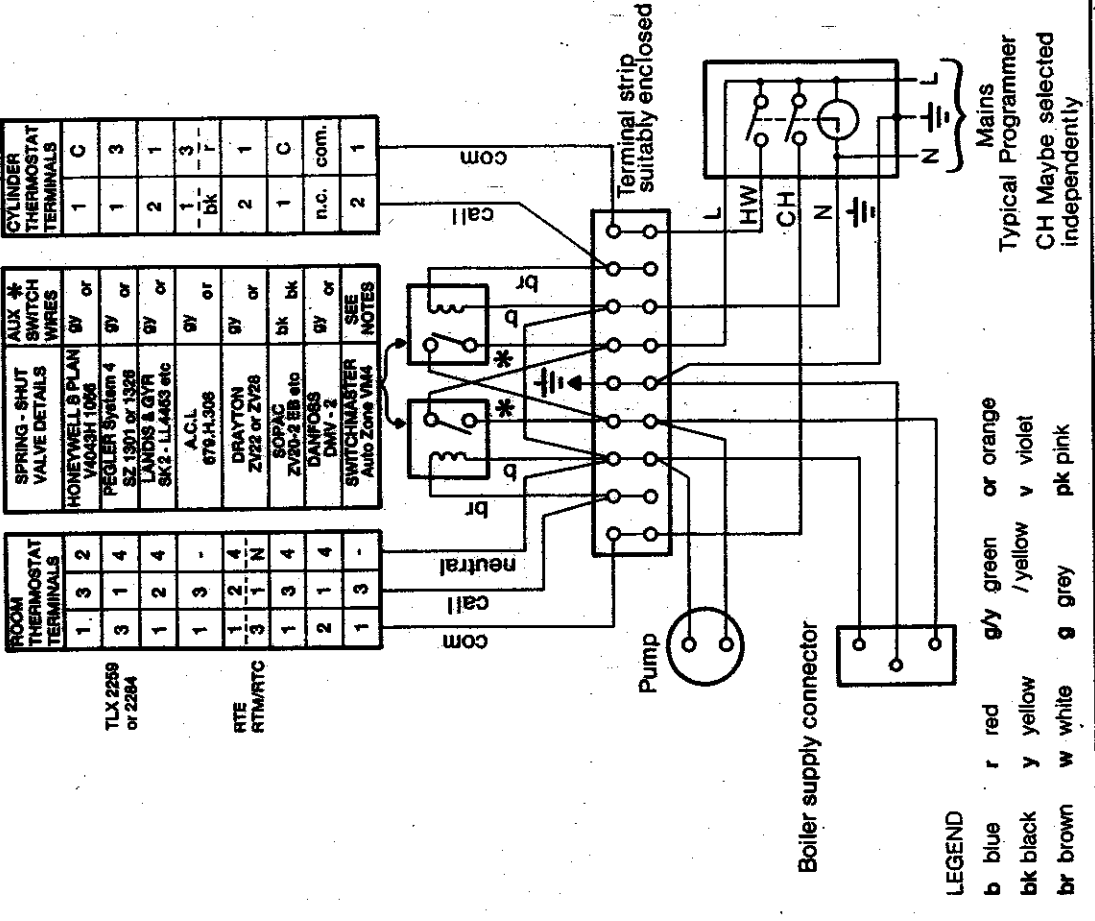

41 ONE VALVE IN HEATING CIRCUIT - Pumped only

1. Some earth wires are omitted for clarity. Ensure proper earth continuity when wiring.
2. Numbering of thermostat terminals applies ONLY to the Manufacturer mentioned.
3. Switchmaster valve also has grey and orange wires, but the GREY wire (not the orange), must be connected to the incoming supply.

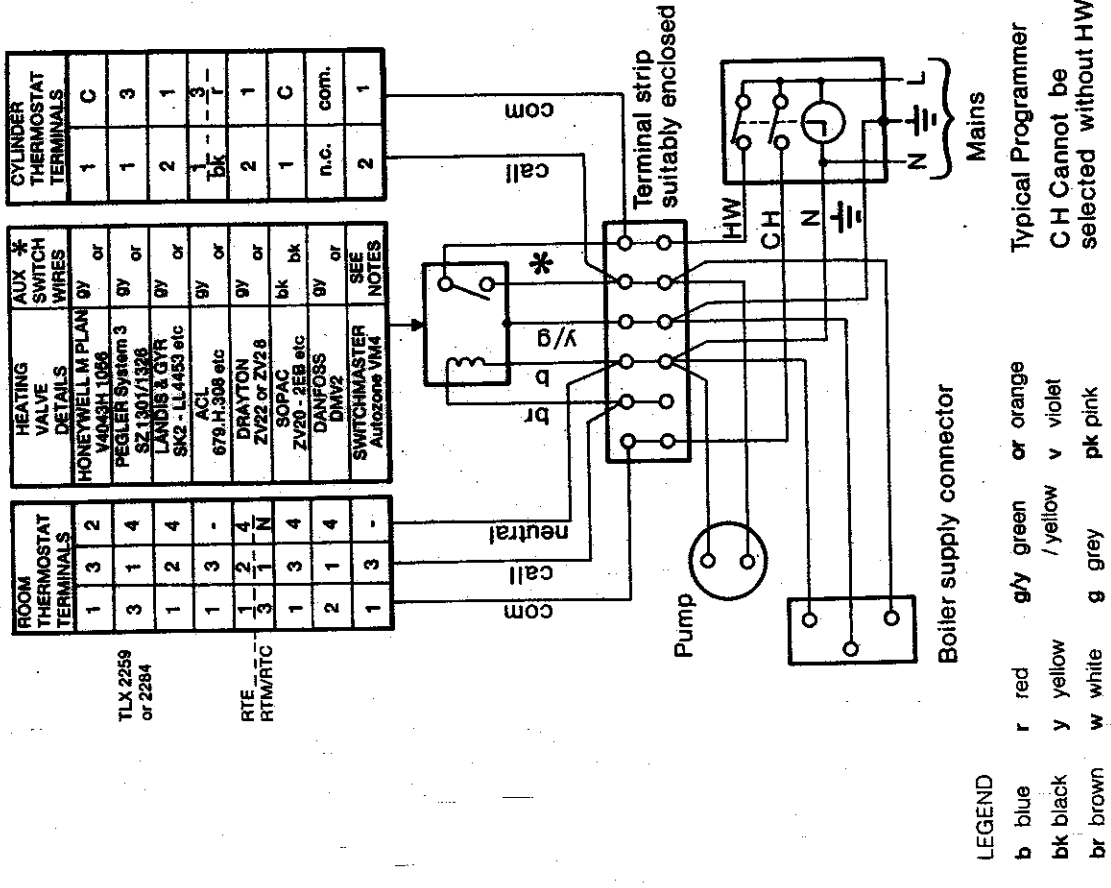

43 FROST PROTECTION

1. The frost thermostat should be wired to the programmer as shown, without disturbing the existing wiring.
2. The frost thermostat should be sited in a cool place in the house, but where it can sense heat from the system.
3. The occupier should be advised that, during frosty weather, the system should be turned OFF at the programmer switches ONLY. All other controls should be left in the normal running position.

TYPICAL PROGRAMMER

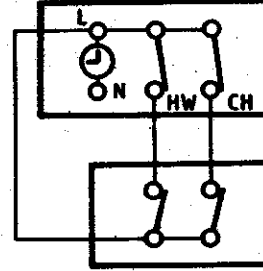

DOUBLE POLE FROST THERMOSTAT

COMMISSIONING AND TESTING

44 COMMISSIONING AND TESTING

(a) Electrical Installation

1. Checks to ensure electrical safety should be carried out by a competent person.
2. ALWAYS carry out the preliminary electrical system checks i.e. earth continuity, polarity, resistance to earth and short circuit using a suitable test meter.

(b) Gas Installation

1. The whole of the gas installation, including the meter, should be inspected & tested for soundness & purged in accordance with the recommendations of BS. 6891.
2. Purge air from the gas installation by loosening the four extended nuts securing the gas service cock and purging until gas is smelled.
3. Retighten the nuts and test for gas soundness.

WARNING. Whilst effecting the required gas soundness test & purging air from the gas installation, open all windows & doors, extinguish naked lights & DO NOT SMOKE.

45 INITIAL LIGHTING

BOILER CONTROLS

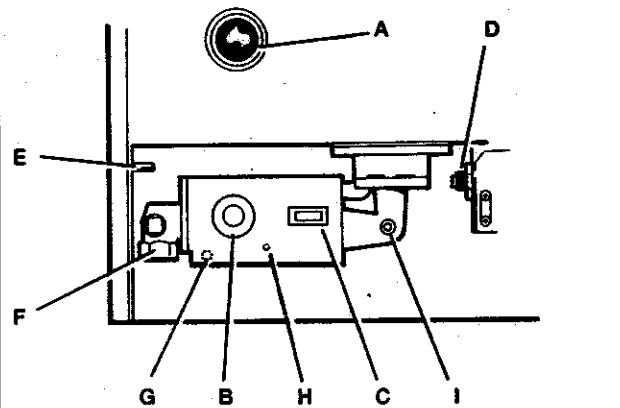

- LEGEND**
- | | |
|-------------------------------------|-------------------------------------|
| A Sightglass. | E Fascia retention catch. |
| B Thermostat knob. | F Gas service cock. |
| C Thermostat ON / OFF switch. | G Inlet pressure test nipple. |
| D Overheat thermostat reset button. | H Main burner pressure adjuster. |
| | I Main burner pressure test nipple. |

1. Check that the electricity supply is OFF.
2. Check that the gas service cock (F) is ON and the boiler thermostat switch (C) is OFF.
3. Slacken the screw in the burner pressure test nipple (I) and connect a gas pressure gauge via a flexible tube.
4. Switch the electricity supply ON and check that all external controls are calling for heat.
5. Set the boiler thermostat knob (B) to position '6' and the thermostat switch (C) to ON. The pilot solenoid valve should open and the intermittent spark commence - continuing until the pilot is established. The main burner will then light.

FITTING THE BOILER CASING.

IMPORTANT. This appliance **MUST NOT** be operated with the casing removed.

- Lift the boiler casing with the glass fascia in the down position up to the boiler assembly & secure with the top two captive screws.
- Slide the fascia up until it locates in the retaining catch.
- Secure the bottom two captive screws.

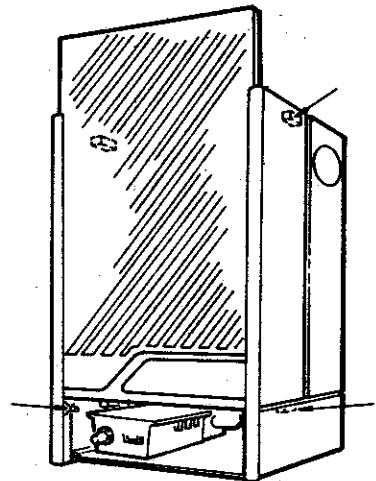

- The casing **MUST** seat correctly and compress the sealing strip to make an airtight joint. If side the clearance is limited then this may be checked by ensuring that the top and bottom edges of the casing are correctly located.
- Check that the pilot flame envelops the ignition / detection electrode. If the pilot flame appears incorrect then refer to Frame 8 'Servicing'. **Note.** The pilot flame is factory set and no adjustment is possible.
6. Test for gas soundness around ALL boiler gas components, particularly valve & manifold flanges, using leak detection fluid.
 7. Set the boiler thermostat switch (C) to OFF and switch OFF the electricity supply.
 8. If the boiler output is to be set to MID or MINIMUM, affix the appropriate indicator label to the Data Plate, located on the bottom R.H. side of the back panel.

46 INITIAL LIGHTING

Continued from Frame 45.

1. Switch the electricity supply ON.
2. Set the boiler thermostat knob (B) to position '6' and the thermostat switch (C) to ON and the fan will start.
3. Once the pilot is established the main gas will come on. Check that the main burner cross lights smoothly. If this sequence does not occur then refer to the 'Fault Finding' section.
4. Operate the boiler for 10 minutes to stabilise the burner temperature.
5. The boiler is pre-set at the factory to its highest nominal rating, but can be range rated to suit the system design requirements. Refer to Table 2 on page 2. Turn the adjusting screw (H) clockwise to decrease the pressure.
6. Set the boiler thermostat switch (C) to OFF.
7. Remove the pressure gauge and tube. Retighten the sealing screw in the pressure test nipple. Ensure a gas tight seal is made.
8. Re-fit the casing bottom panel.

47 GENERAL CHECKS

Make the following checks for correct operation:

1. Set the boiler thermostat knob to position '6' and operate the thermostat ON/OFF switch. Check that the main burner lights and extinguishes in response.
2. The correct operation of ANY programmer and all other system controls should be proved. Operate each control separately and check that the main burner or circulating pump, as the case may be, responds.
3. Check that the casing is sealed correctly and compressing the sealing strip all around the casing.
4. **Water Circulation System**
 - (a) With the system HOT, examine all water connections for soundness.
 - (b) With the system still hot, turn off the gas, water and electricity supplies to the boiler and drain down in order to complete the flushing process.
 - (c) Re-fill and vent the system, clear all air locks and again check for water soundness.
 - (d) Balance the system and set the by-pass.
5. Finally set the controls to the User's requirements and slide the glass fascia down into the closed position.
 - If an optional Programmer Kit is fitted then refer to the instructions supplied with the kit.
 - The temperatures quoted below are approximate and vary between installations.

Knob Setting	Flow Temperature	
	°C	°F
1	54	130
2	60	140
3	66	150
4	71	160
5	77	170
6	82	180

WARNING. The boiler MUST NOT be operated with the casing removed.

48 HANDING OVER

After completing the installation and commissioning of the system, then the installer should hand over to the householder by the following actions:

1. Hand the User's Instructions to the Householder and explain his or her responsibilities under the Gas Safety (Installation and Use) Regulations 1984.
2. Draw attention to the Lighting Instruction label affixed to the casing front and visible through the observation window in the glass fascia when in the raised position.
3. Explain and demonstrate the lighting and shutting down procedures.
4. The operation of the boiler and the use and adjustment of ALL system controls should be fully explained to the Householder, to ensure the greatest possible fuel economy, consistent with household requirements of both heating and hot water consumption.
5. Advise the User of the precautions necessary to prevent damage to the system and to the building, in the event of the system remaining inoperative during frosty conditions.
6. Explain the function and the use of the boiler thermostat and external controls.
7. Explain the function of the boiler over-heat thermostat and emphasise that if cut-out persists, the boiler should be turned off and the local Heating Installer consulted.
8. Explain and demonstrate the function of time and temperature controls, radiator valves, etc for the economic use of the system.
9. If any Programmer Kit is fitted, then draw attention to the Programmer Kit User's instructions and hand them to the Householder.
10. Stress the importance of regular servicing by the Local Gas Region or by a qualified Heating Engineer and that a comprehensive service should be carried out AT LEAST ONCE A YEAR.

1 SCHEDULE

To ensure the continued safe and efficient operation of the appliance, it is recommended that it is checked at regular intervals and serviced as necessary. The frequency of servicing will depend upon the installation condition and usage, but should be carried out at least annually. It is the law that any service work must be carried out by a competent person.

- Light the boiler and carry out a pre-service check, noting any operational faults.
- Clean the main burner.
- Clean the heat exchanger.
- Clean the main and pilot injectors.
- Check that the flue terminal is unobstructed and that the flue system is sealed correctly.
- If the appliance has been installed in a compartment, check that the ventilation areas are clear.

The servicing procedures are covered more fully in Frames 2 to 8 and must be carried out in sequence.

WARNING. Always turn off the gas supply at the gas service cock and and switch off & disconnect the electricity supply to the appliance before servicing.

IMPORTANT. After completing the servicing or exchange of components always test for gas soundness and carry out functional checks as appropriate.

Note. In order to carry out either servicing or replacement of components, the boiler casing must be removed (Frame 2).

IMPORTANT. When work is complete the casing **MUST** be correctly refitted, ensuring that a good seal is made: **DO NOT OPERATE THE BOILER IF THE CASING IS NOT FITTED.**

2 BOILER CASING REMOVAL

- Release the top two captive screws.
- Slide the glass fascia upwards until it locates in the retaining catch.
- Remove the two securing screws, slide the bottom panel forward slightly, and then sideways to remove from the casing.

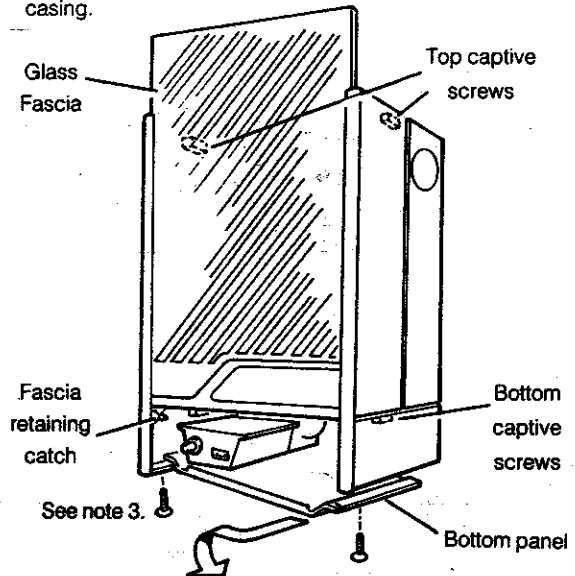

- Release the two bottom captive screws and lift the casing off the boiler. Place the casing safely to one side, taking care not to damage the glass fascia panel. Slide the glass panel down in the casing for safe keeping.

3 BURNER AND AIR BOX REMOVAL

- Remove the wing nut securing the burner front support bracket. Remove the M5 pozi screw situated at the left hand, bottom rear of the burner & pull the burner downwards in order to disengage the retention tab. Remove the burner to a safe place for inspection & cleaning.

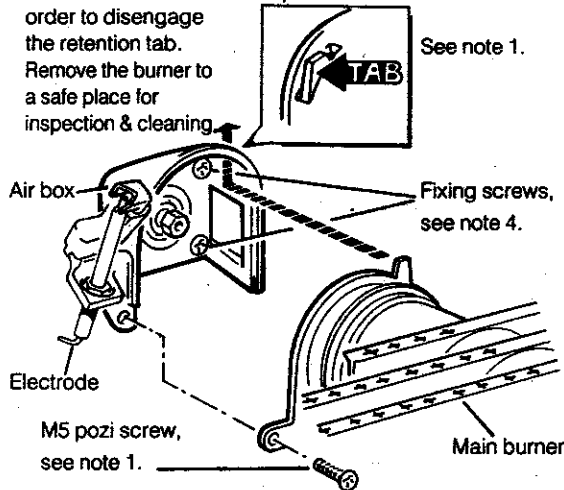

- Remove the control box lid fixing screws. Pull the lid forwards and upwards to disengage the catches and remove the lid.
- Pull the H.T. lead connection off the printed circuit board and pull the lead through the bottom panel grommet.

VIEW OF CONTROL BOX.
Shown with lid removed.

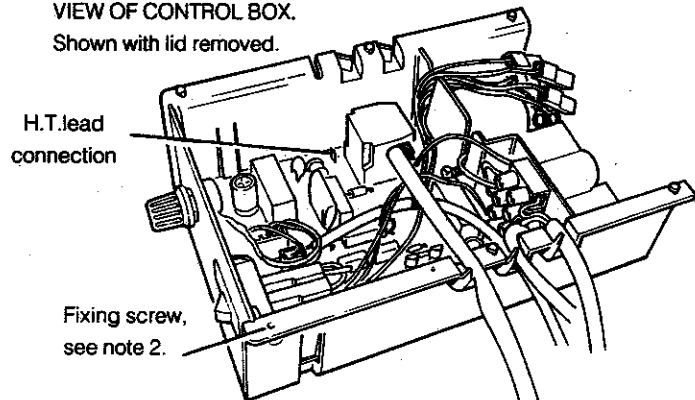

- Remove the four screws retaining the air box / pilot assembly to the vertical manifold & remove the assembly.

4 CLEANING THE FAN ASSEMBLY

- Disconnect the fan electrical leads and unclip the harness from the fan plate
- Disconnect the pressure sensing tube from the fan.
- Remove the four screws, each with two washers, securing the fan assembly to the collector hood.
- Slide the fan assembly clear of the boiler, disengaging the fan outlet elbow from the flue.

- Remove the fan plate to check that the fan impeller runs freely. Clean with a soft brush or renew as necessary, refer to Frame 18

Note. Always take care when handling the fan, due to the balance of the impeller.

- Check that the boiler air inlet duct and the duct are unobstructed.

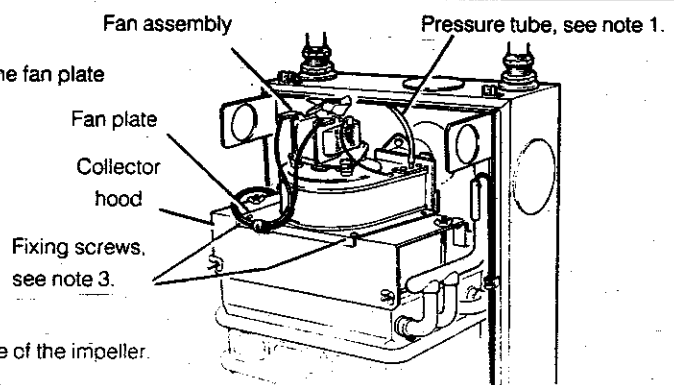

5 CLEANING THE FLUEWAYS

1. Slacken the 4 wing nuts, disengage the tie rods and remove the flue collector hood.
2. Disconnect the pressure switch sensing pipe.

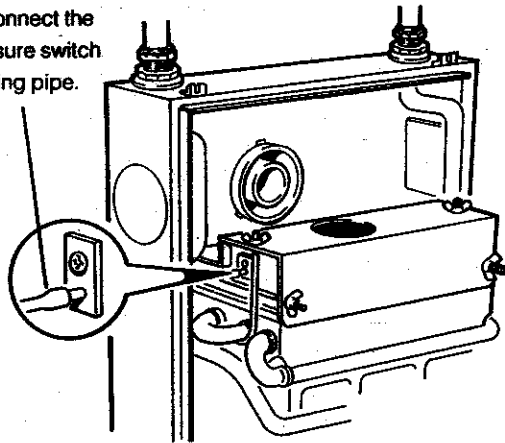

3. Place a plastic sheet, or similar, beneath the boiler and remove all loose deposits from the heat exchanger finned block and copper skirt using a suitable brush and / or clearing rod - brushing from above and below.

6 CLEANING THE BURNER AND PILOT ASSEMBLY

1. Brush off any deposits that may have fallen on to the burner head, ensuring the flame ports are un-obstructed and remove any debris that may have collected.
Note. Brushes with metallic bristles **MUST NOT** be used.
2. Remove the main burner injector and ensure there is no blockage or damage. Clean or renew as necessary.
3. Refit the injector using an approved jointing compound sparingly.
4. Inspect the pilot burner & ignition / detection electrode. Ensure that they are clean & in good condition. Check that:
 - (a) The pilot burner injector is not blocked or damaged. Refer to Frame 13 for removal details.
 - (b) The pilot burner is clean and unobstructed.
 - (c) The ignition/detection electrode is clean and undamaged.
 - (d) The ignition / detection lead is in good condition.
 - (e) The spark gap is correct (Frame 13). Clean or renew as necessary.

7 RE-ASSEMBLY

Re-assemble the boiler in the following order:

1. Refit the flue collector hood - renewing any damaged or deteriorating sealing gasket.
Note. Enter the horizontal tie rods, with the hooks vertical, through the collector hood slots and engage in the holes in the retention angle.
2. Reconnect the pressure switch sensing pipe.
3. Refit the fan mounting plate assembly, taking care to reconnect the pressure sensing pipe.

4. Refit the air box assembly and burner.
5. Refit the control box cover.
6. Turn on the gas supply at the gas service cock.
7. Re-connect the electricity supply.
8. Check the sightglass in the boiler casing. Clean or renew as necessary. Refer to Frame 10.
9. Refit the boiler casing.

IMPORTANT. When work is complete the casing **MUST** be correctly re-fitted. Ensure that a good seal is made.

8 GAS PRESSURE ADJUSTMENT

PILOT Light the boiler and check that the pilot flame envelopes the ignition / detection electrode.

DETAIL OF SPARK GAP

3 to 5 mm

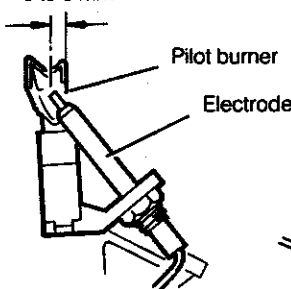

25 mm (1 in.)

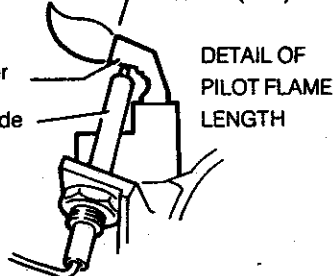

The pilot is factory set to maximum and no further adjustment is possible. However, if the pilot flame length is incorrect then remove and inspect the pilot injector. Refer to Frame 13. Relight in accordance with 'Initial Lighting'. Refer to Frame 46 'Installation'.

MAIN BURNER

After any servicing, reference should be made to Table 2 which quotes details of the rated output with the related burner setting pressure and the heat input. Any required adjustments should be made by using the pressure adjustment screw. Refer to 'Initial Lighting', Frame 46 'Installation'.

REPLACEMENT OF PARTS

9 GENERAL

When replacing any component:

1. Isolate the electricity supply.
2. Turn OFF the gas supply.
3. Remove the boiler casing. Refer to Frame 2.

IMPORTANT. When work is complete the casing **MUST** be correctly refitted, ensuring that a good seal is made.

Note. In order to assist fault finding the control box printed circuit board is fitted with 4 indicator lights which represent the following boiler conditions:

- Neon I1.** Air pressure switch made.
- Neon I2.** Boiler thermostat calling for heat.
- Neon I3.** Mains electricity ON.
- Neon SG1.** Flashes to indicate spark operation (stops after detection).

The boiler MUST NOT be operated if the casing is not fitted.

10 SIGHTGLASS REPLACEMENT

1. Refer to Frame 9.
2. Remove the glass fascia panel from the casing.
3. Unfasten the 2 nuts & washers & remove the assembly.

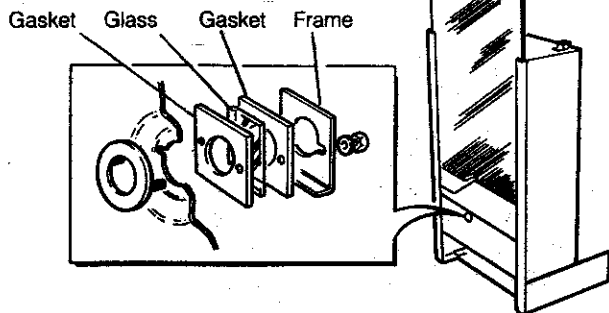

4. Fit the new sightglass and re-assemble as shown.
5. Retighten the two nuts to ensure an airtight seal. **DO NOT OVERTIGHTEN.**
6. Refit the fascia panel & replace the boiler casing (Frame 7).

12 OVERHEAT THERMOSTAT REPLACEMENT

1. Refer to Frame 9.
2. Remove the fan assembly. Refer to Frame 4.
3. Release the sensing head from the thermostat clamp.
4. Release the capillary from the top clip.
5. Unscrew and remove the heat shield.
6. Unscrew the two screws & remove the cover plate.

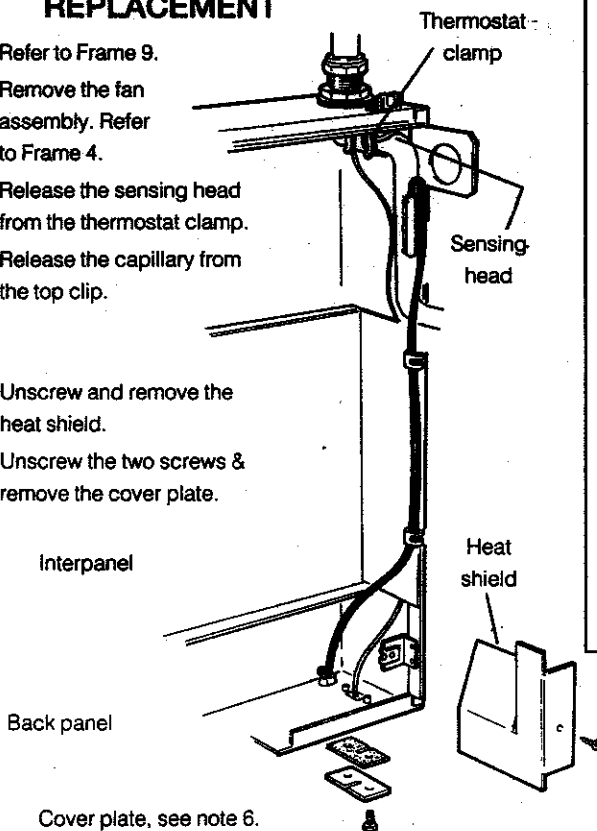

7. Remove the screw securing the overheat thermostat bracket to the pressure switch bracket and withdraw the complete assembly.
8. Remove the thermostat retaining nut and withdraw the thermostat.
9. Disconnect the 2 electrical leads & remove the thermostat from the boiler.
10. Fit the new thermostat and re-assemble in reverse order, ensuring that;
 - (a) The thermostat capillary is routed between the side of the interpanel and the boiler back panel.
 - (b) If a right hand side flue is fitted the thermostat capillary is clear of the side outlet flue pipe.
 - (c) All excess capillary length is neatly coiled behind the pressure switch and clear of the casing.
 - (d) The heat shield is replaced.

11 CONTROL THERMOSTAT AND LEAD REPLACEMENT

Refer also to Frame 27 of 'Exploded Views' & Frame 39 'Installation'.

1. Refer to Frame 9.
2. Remove the control box lid fixing screws. Pull the lid forward and upward to disengage the catches and remove the lid.
3. Unclip and remove the front panel by lifting it upwards.

VIEW OF BOILER CONTROL BOX. Shown with cover removed.

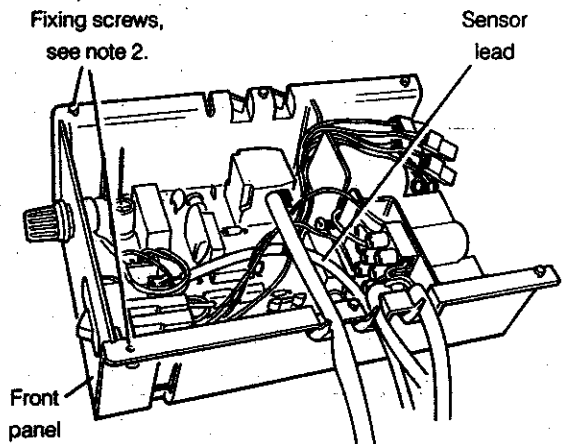

4. Disconnect the thermostat sensor lead from the P.C.B. and unclip it from the strain relief slot.

5. Withdraw the thermostat sensor from the pocket on the heat exchanger flow pipe and unclip the lead from the back panel.
6. Release the lead from the strain relief bush in the bottom of the back panel and remove the assembly from the boiler.

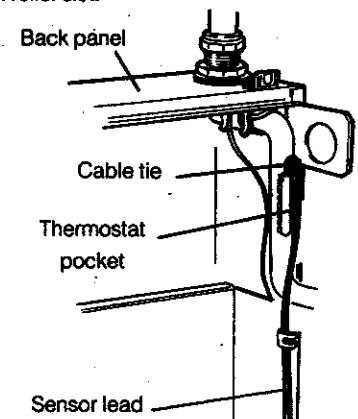

5. Fit the new thermostat sensor & re-assemble in reverse order. Fitting the new cable tie and re-charging the pocket with the heat sink compound provided.

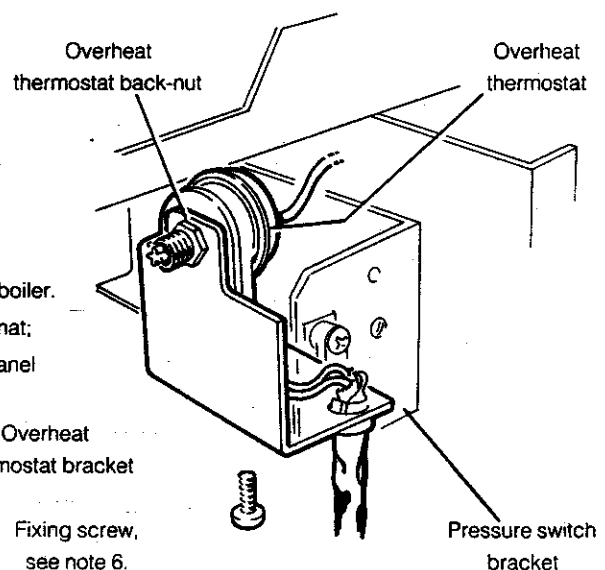

13 PILOT BURNER REPLACEMENT

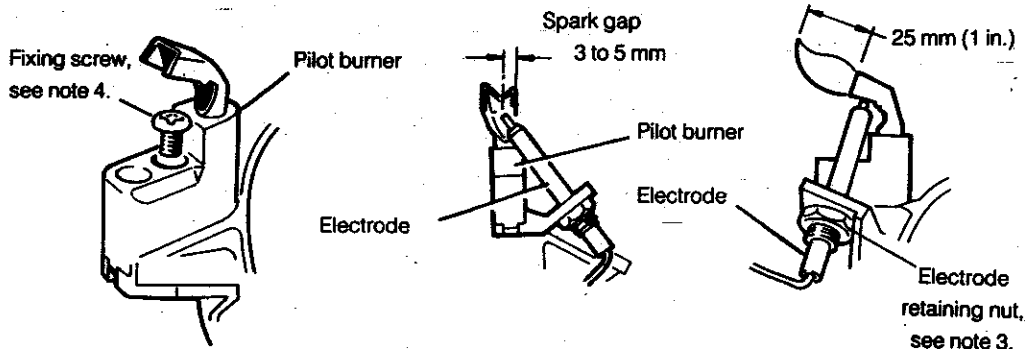

1. Refer to Frame 9.
2. Remove the burner and air box assembly. Refer to Frame 3.
3. Remove the electrode retaining nut and withdraw the electrode
4. Unscrew the central pilot fixing screw and lift the pilot clear of the pilot injector.

Note. The pilot injector may now be unscrewed if required, taking care not to lose the copper sealing washer.

5. Fit the new pilot burner assembly (and injector if necessary) and re-assemble in reverse order, ensuring that;
 - (a) The spark gap and pilot flame length are correct.
 - (b) The pilot injector copper sealing washer is re-fitted.
6. Check the pilot burner relationship to the main burner & the spark gap.
7. Replace the boiler casing. refer to Frame 7.
8. Check the pilot length.
9. Check the pilot operation (cross lighting, etc.).

14 SPARK ELECTRODE AND LEAD REPLACEMENT

1. Refer to Frame 9.
2. Remove the burner and air box assembly. Refer to Frame 3.
3. Remove the electrode retaining nut.

DETAIL OF PILOT BURNER

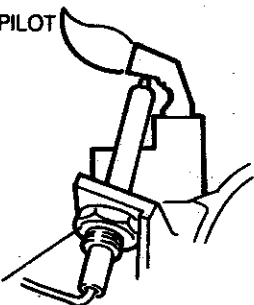

4. Remove the spark electrode and integral lead.
5. Refit the new electrode and lead in reverse order.
6. Check the spark gap. Refer to frame 13.
7. Refit the burner.
8. Replace the boiler casing. Refer to Frame 7.
9. Check the pilot ignition.

15 MAIN BURNER AND MAIN BURNER INJECTOR REPLACEMENT

1. Refer to Frame 9.
2. Remove the wing nut retaining the front burner support bracket. Refer to Frame 3.
3. Remove the M5 pozi screw and washer, situated at the left hand bottom rear of the burner. Pull the burner downwards to disengage the retention tab and remove the burner.
4. Withdraw the burner from the boiler.
5. At this stage the main burner injector can be removed, checked, cleaned or replaced as required. Ensure that an approved jointing compound is used sparingly.
6. Transfer the front support bracket to the new burner.
7. Fit the new burner, ensuring that the retention tab is correctly located in the air box slot.
8. Refit M5 retaining screw and washer.
9. Refit the boiler casing. Refer to Frame 7.
10. Check the burner for cross-lighting and flame stability.

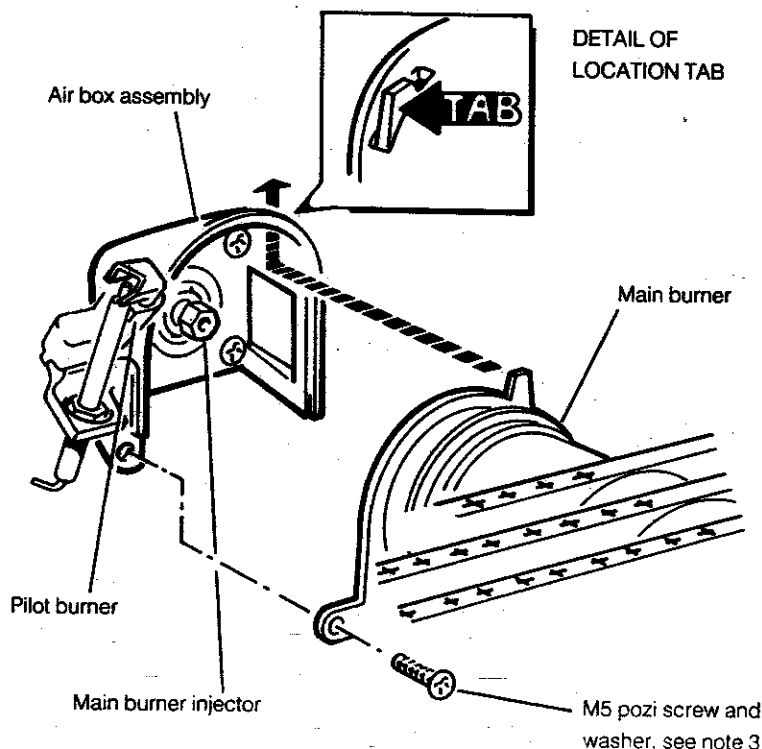

16 GAS CONTROL VALVE REPLACEMENT

Note. Also refer to Frame 26 of 'Exploded Views' for illustration of the procedure detailed below.

1. Refer to Frame 9.
2. Remove the control box as follows:
 - (a) Remove the lid and unclip the front panel. Refer to Frame 11.
 - (b) Pull off the connections at the printed circuit board. Refer to Frame 39 'Installation'.
 - (c) Release the central fixing screw. Refer to Frame 27. Withdraw and suspend the control box.
 - (d) Pull off the solenoid electrical connections and unscrew the earth lead at the gas control valve. Refer to Frame 39 'Installation'.
 - (e) Suspend the control box from the incoming mains lead.
3. Remove the four M4 extended nuts securing the gas service cock to the gas valve.
4. Whilst supporting the gas control valve, remove the two screws retaining the manifold to the back panel.
6. Remove the four screws securing the manifold extension to the gas control valve and withdraw the valve.
7. Fit the new gas control valve, ensuring that:
 - (a) The valve is fitted the correct way round (an arrow engraved on the back indicates the direction of flow).
 - (b) The sealing gasket and 'O' ring supplied with the valve are correctly fitted.
8. Re-assemble in reverse order.
9. Replace the burner / air box assembly.
10. Replace the boiler casing. Refer to Frame 7.
11. Check the gas valve operation.

17 GAS CONTROL VALVE SOLENOID REPLACEMENT

1. Refer to Frame 9.
2. Remove the control box from the gas control valve. Refer to Frame 16.
3. Slide out the spring clip and remove the solenoid from the gas control valve.
4. Fit the new solenoid and re-assemble in reverse order.

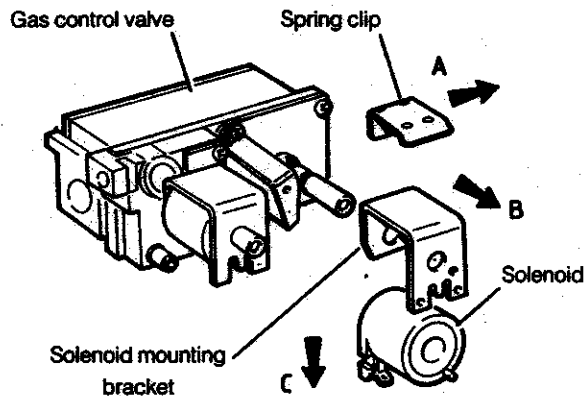

18 FAN UNIT REPLACEMENT

1. Refer to Frame 9.
2. Disconnect the pressure sensing tube from the fan.
3. Disconnect the fan electrical leads and unclip the harness from the fan mounting plate.
4. Remove the four screws securing the fan assembly.
5. Slide the fan assembly clear of the boiler, disengaging the fan outlet elbow from the flue. **Note.** Always take care when handling the fan in order to preserve the balance of the impeller.
6. Transfer the pressure sensing pipe connector to the new fan.
 - Pressure tube, see note 2.
 - Fan assembly
 - Collector hood
 - Harness, see note 3.
7. Fit the new fan in reverse order.
8. Refit the boiler casing. Refer to Frame 7.
9. Check the boiler operation.

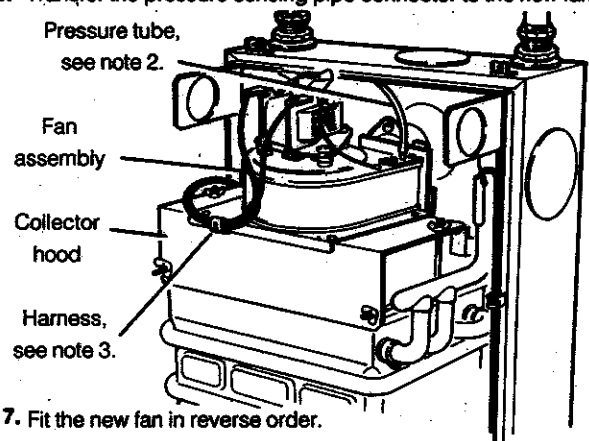

19 PRESSURE SWITCH REPLACEMENT

1. Refer to Frame 9.
2. Pull both of the sensing tubes off the pressure switch.
3. Remove the two screws securing the pressure switch to the back panel and withdraw the switch.
4. Remove the pressure switch cover by removing the fixing screw
5. Disconnect the three electrical leads.
6. Transfer the electrical connections to the new pressure switch. Yellow to No.2, red to No. 3 and violet to No. 1.
7. Fit the new pressure switch and re-assemble in reverse order. Ensure that the 2 rubber pipes are re-connected to the correct pressure switch connections (red pipe to lower connection marked with a red dot and white pipe to upper connection).
8. Refit the boiler casing. Refer to Frame 7.
9. Check the boiler operation.

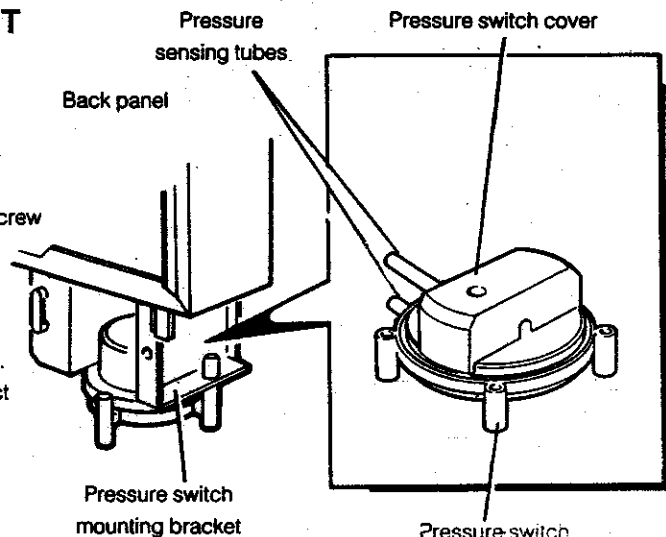

20 CONTROL THERMOSTAT POTENTIOMETER REPLACEMENT

1. Refer to Frame 9.
2. Remove the control box lid. Refer to Frame 11.
3. Pull the potentiometer knob off the shaft & remove the back nut.
4. Unplug the potentiometer lead from the P.C.B. and withdraw the potentiometer from the control box.
5. Fit the new potentiometer and re-assemble in reverse order.
6. Refit the boiler casing. Refer to Frame 7.
7. Check the operation of the thermostat.

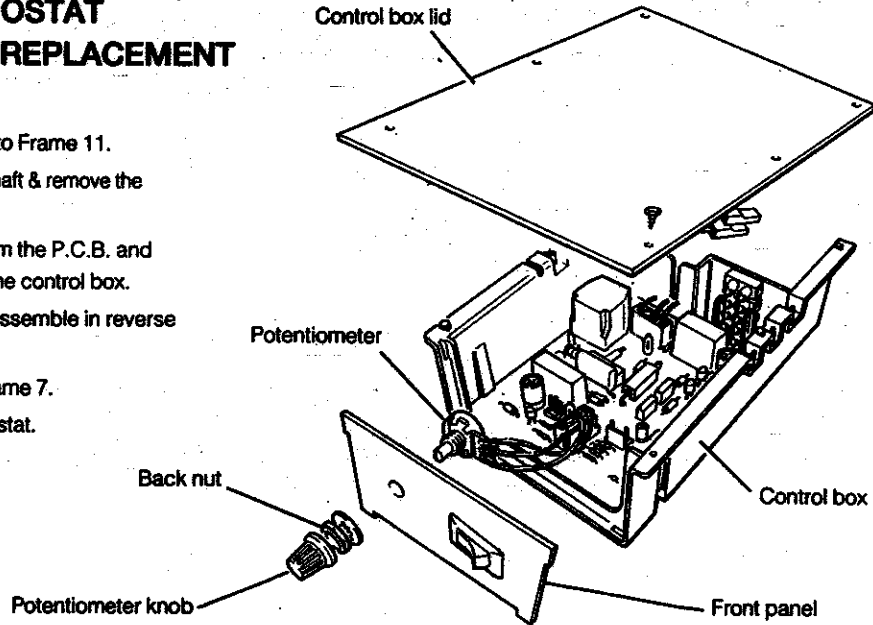

21 THERMOSTAT SWITCH REPLACEMENT

1. Refer to Frame 9.
2. Remove the control box lid. Refer to Frame 11.
3. Disconnect the two electrical leads from the switch.
4. Compress the retaining clips and prise the defective switch out of the front panel.
5. Fit the new switch and re-assemble in reverse order. Ensure that the switch is the correct way round, i.e. with the terminals towards the right, as shown. Polarity is immaterial.
6. Refit the boiler casing. Refer to Frame 7.
7. Check the operation of the thermostat.

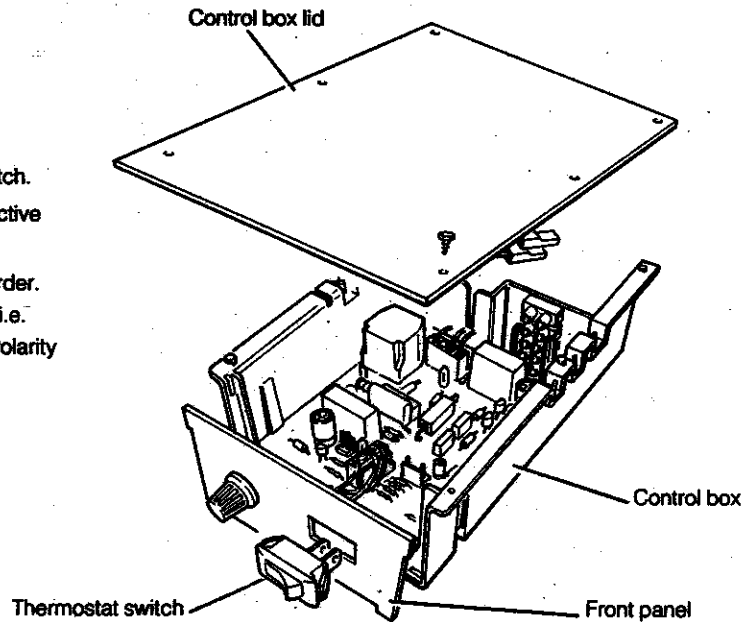

22 AUTOMATIC IGNITION P.C.B. REPLACEMENT

1. Refer to Frame 9.
2. Remove the control box lid. Refer to Frame 11.
3. Disconnect the ignition / detection lead from the P.C.B.
4. Disconnect the four plug-in leads from the P.C.B.
5. Disconnect the two leads from the thermostat switch.
6. Slide the 5-way terminal strip from its housing and remove the three wires connected to the P.C.B.
7. Remove the control box central fixing screw (refer to Frame 27), draw the box forward and disconnect the four electrical leads from the gas valve solenoids.
8. Depress the two side retaining tabs and remove the P.C.B.
9. Fit the new P.C.B. and re-assemble in reverse order. Ensure that all electrical connections are correctly re-made. Refer to Frames 37 & 39 'Installation'.
10. Refit the boiler casing. Refer to Frame 7.
11. Check the ignition operation.

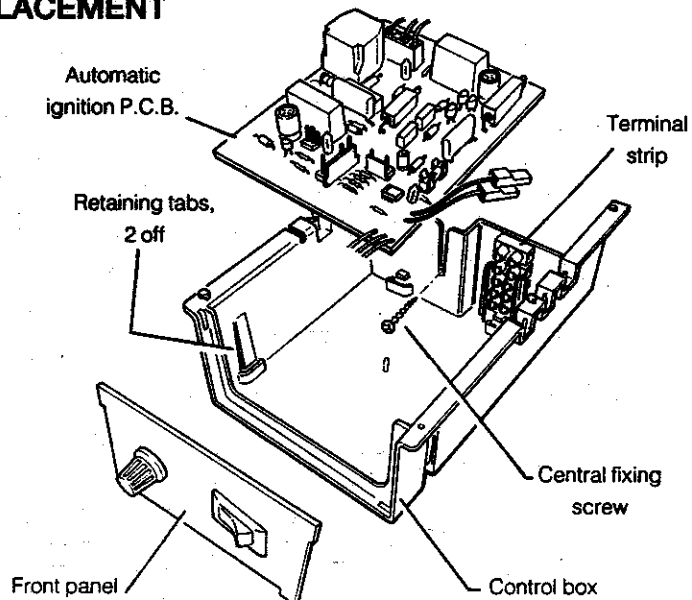

23 HEAT EXCHANGER REPLACEMENT

IMPORTANT. Before starting the removal procedure, protect the gas electrical controls with a waterproof sheet or plastic bag.

1. Refer to Frame 9.
2. Drain down the system and heat exchanger.
3. Remove the fan assembly. Refer to Frame 4.
4. Remove the burner and air box assembly. Refer to Frame 3.
5. Remove the flue collector hood. Refer to Frame 5.
6. Remove the control thermostat sensor and the overheat thermostat - complete with clamp. Refer to Frames 11 & 12.
7. Undo the nut and remove the retaining bracket.
8. Remove the two M5 screws in the top of the back panel and remove the pipe retention plates (80 NF only).
9. Disconnect the boiler flow & return fittings. Remove the back nuts.
10. Withdraw the heat exchanger - swinging forwards at the bottom, downwards and outwards.

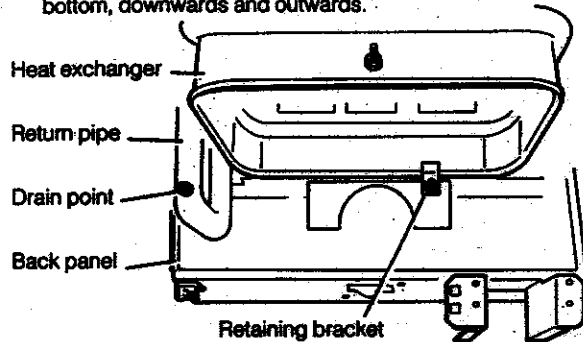

11. Fit the new heat exchanger and re-assemble in reverse order.

24 CASING SEAL REPLACEMENT

1. Refer to Frame 9.

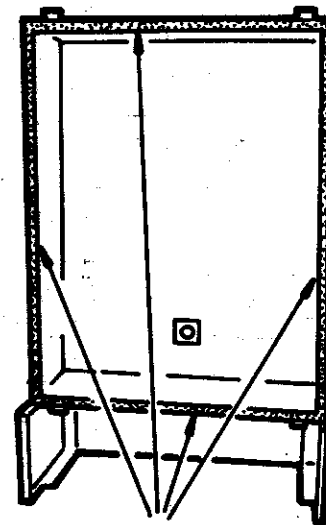

2. Remove the old seals from the channel in the casing, and press in the new seals (4 pieces).
3. Replace the boiler casing. Refer to Frame 7.

Note. Ensure that the casing is correctly seated - compressing the sealing strip to make an airtight joint. If side clearances are limited, then this can be checked by ensuring that top and bottom edges of the casing are correctly located.

24 PROGRAMMER REPLACEMENT (if fitted)

1. Refer to Frame 9.
2. Remove the boiler control box lid and release the terminal strip from its slide retention. Disconnect the 'L', 'N' & 'E' connections from the terminal strip and release the cable clamps.
3. Remove the 2 screws retaining the programmer mounting bracket to the back panel mounting bracket.

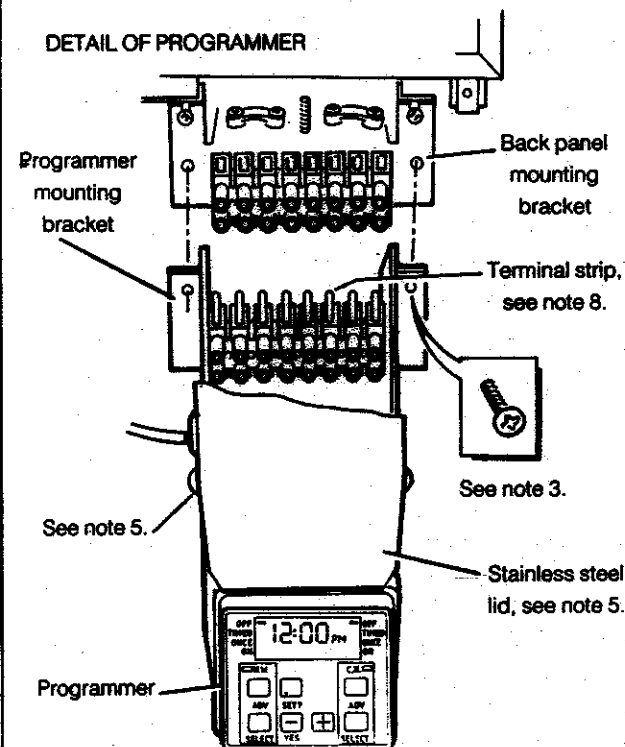

DETAIL OF BOILER CONTROL BOX

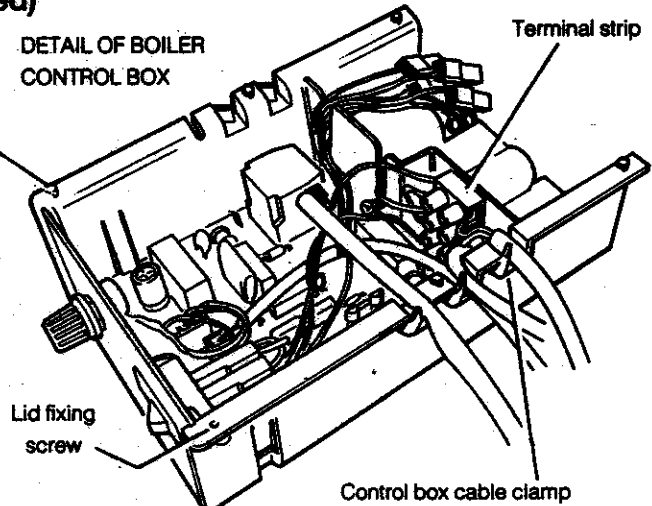

4. Pull the programmer mounting bracket downward and forward in order to disengage the terminal strip connection.
5. Remove the 2 screws fastening the stainless steel lid to the programmer mounting bracket and remove the lid.
6. Slide the programmer upwards in order to clear the mounting bracket.
7. Remove the strain relief bush retaining the control box feed cable and remove the earth lead from the earth post.
8. Remove the 3 screws retaining the terminal strip to the programmer mounting bracket.
9. Remove the programmer, complete with its terminal strip and wiring harness.
10. Fit the new programmer, terminal strip and wiring harness in reverse order.
11. Set the programmer to the desired programme & test its functions.

26 BURNER ASSEMBLY - Exploded view

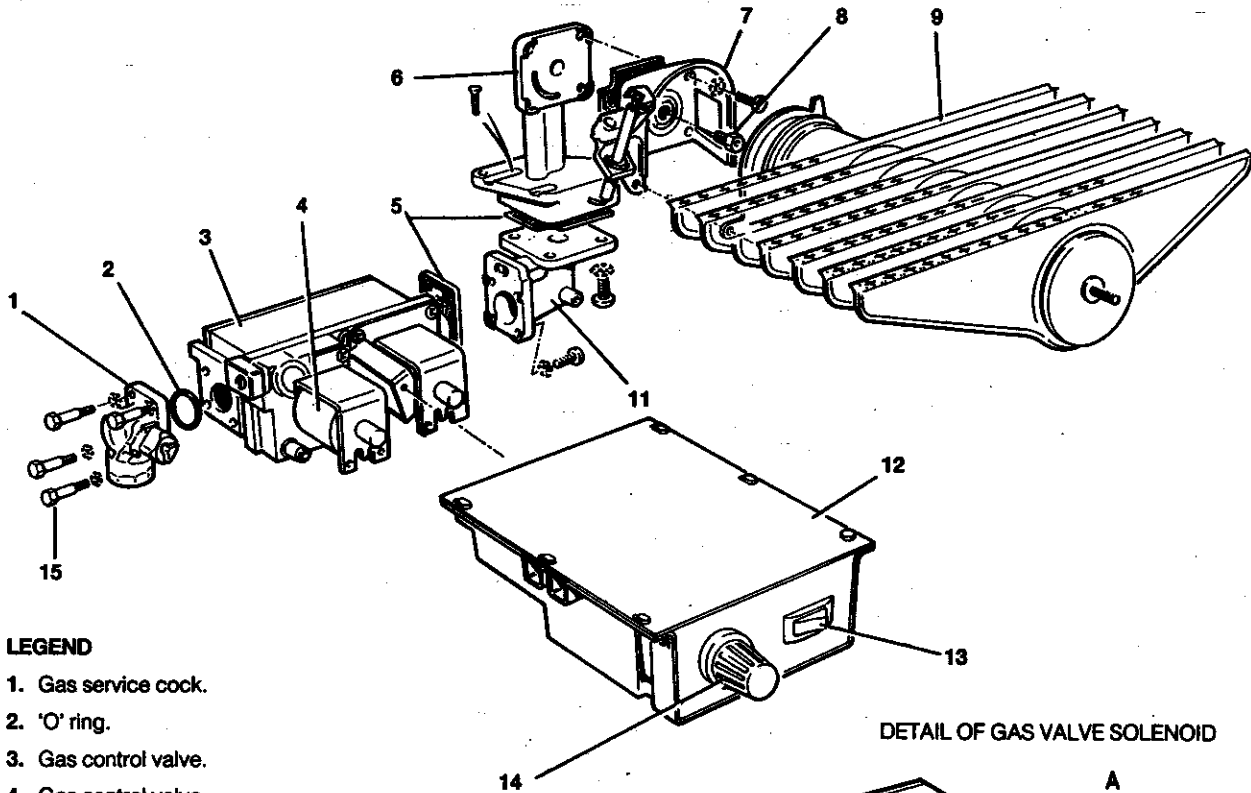

LEGEND

- 1. Gas service cock.
- 2. 'O' ring.
- 3. Gas control valve.
- 4. Gas control valve solenoid.
- 5. sealing gaskets.
- 6. Burner manifold.
- 7. Air box & pilot assembly.
- 8. Main burner injector.
- 9. Main burner.
- 11. Burner manifold extension.
- 12. Control box.
- 13. Mains ON / OFF switch.
- 14. Thermostat knob.
- 15. Extended screws.

DETAIL OF GAS VALVE SOLENOID

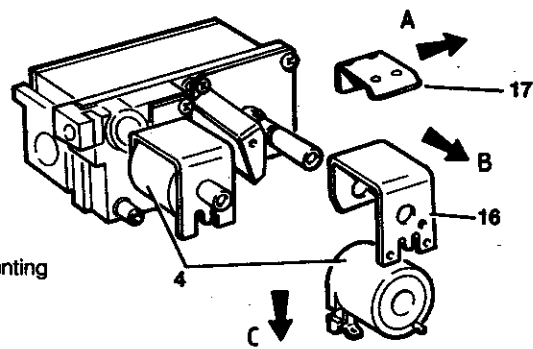

27 CONTROL BOX ASSEMBLY - Exploded view

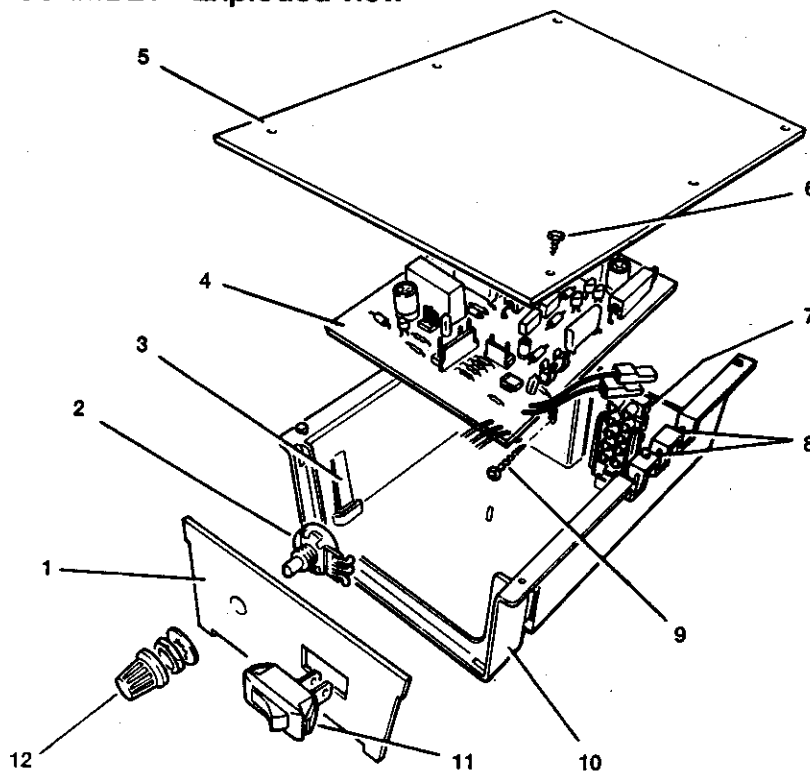

LEGEND

- 1. Control box front cover.
- 2. Thermostat potentiometer.
- 3. Printed circuit board retaining clips.
- 4. Printed circuit board.
- 5. Control box lid.
- 6. Control box lid fixing screws.
- 7. Mains input connector.
- 8. Strain relief bushes.
- 9. Central fixing screw.
- 10. Control box.
- 11. Mains ON / OFF switch.
- 12. Thermostat knob.

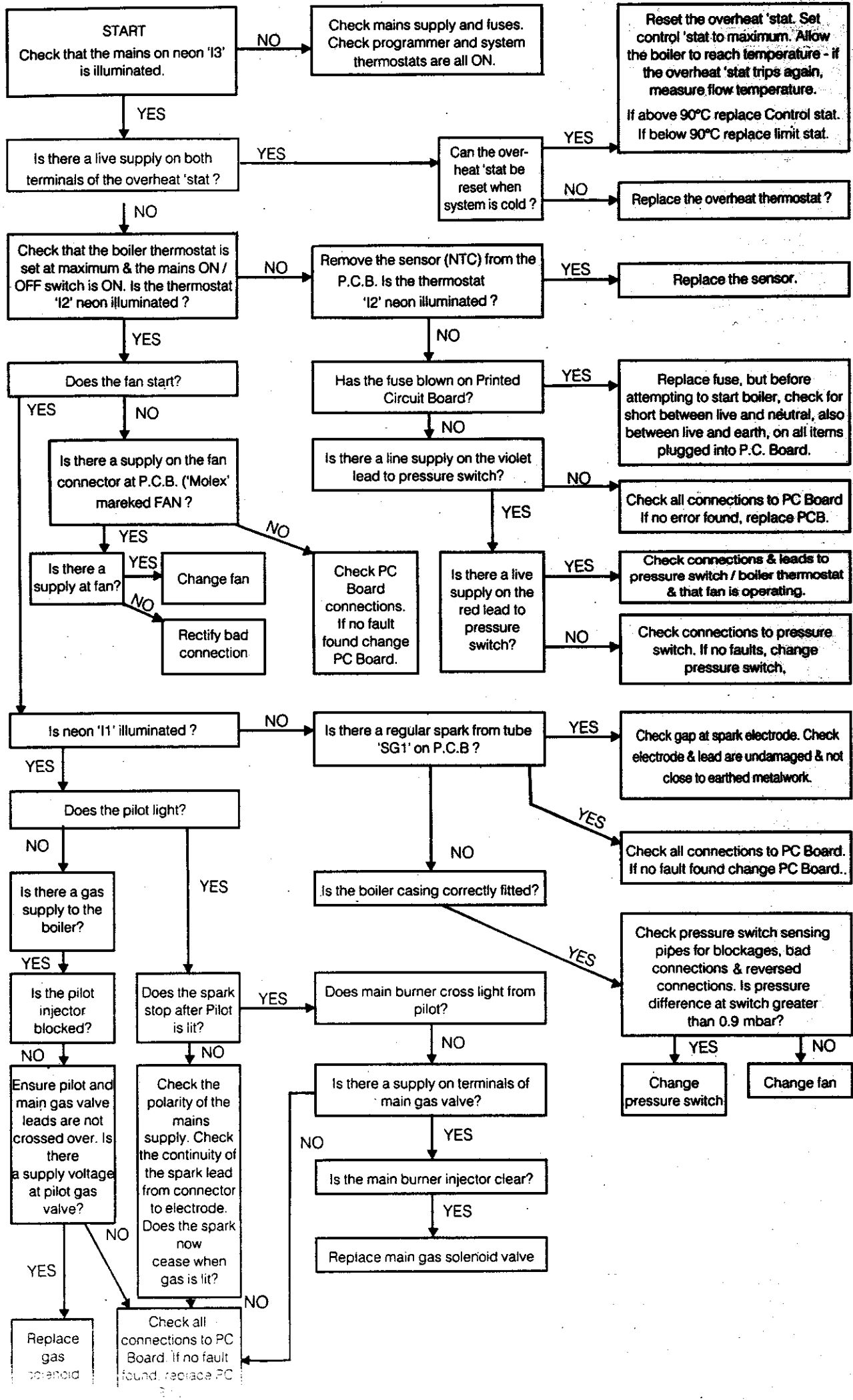

Ideal Elan 2 NF 230, NF 240, NF 250, NF 260 and NF 280 Gas Boilers.

The following list comprises parts commonly required as replacement components due to damage, expendability, or such that their failure or absence is likely to affect safety or performance. The list is extracted from the British Gas List of Parts, which contains all available spare parts.

Details of the British Gas Lists are held by Gas regions, CARADON Distributors and by Merchants.

When ordering spares please quote:

1. Boiler Model
2. Appliance G.C. Number
3. Description
4. Maker's Part Number
5. Quantity

Key No.	G.C. Part No.	Description	No. Off	Product Code No.
3	319 493	Sightglass assembly kit.	1	079 333
5		Main burner.		
	386 235	AEROMATIC No. AC 19/123 278; NF 230	1	113 207
	386 236	AEROMATIC No. AC 19/123 279; NF 240	1	113 208
	386 233	AEROMATIC No. AC 19/123 276; NF 250 & NF 260	1	113 209
	386 234	AEROMATIC No. AC 19/123 277; NF 280	1	113 210
6		Main burner injector.		
	398 315	BRAY Cat. 16 - size 750; NF 230	1	002 773
	398 339	BRAY Cat. 16 - size 1100; NF 240	1	003 279
	398 329	BRAY Cat. 16 - size 1400; NF 250	1	003 962
	398 332	BRAY Cat. 16 - size 1700; NF 260	1	003 213
	398 066	BRAY Cat. 10 - size 2400; NF 280	1	004 444
8	308 347	Pilot burner. HONEYWELL Q 359 A 1124	1	079 599
9		Pilot burner injector.		
	386 131	HONEYWELL 45900421 - 001; NF 230 & NF 240	1	004 981
	386 150	HONEYWELL 45900421 - 002; NF 250, NF 260 & NF 280	1	004 982
10	308 359	Gas control valve.		
		HONEYWELL VR 4700 E 1042, 240 V	1	079 600
11	308 281	Control box, including control thermostat potentiometer, control thermostat, sensor lead, control thermostat knob and mains ON / OFF switch.	1	137 656
12	308 317	Ignition electrode. VERNITRON No. 1414	1	113 172
15	386 149	Automatic ignition printed circuit board.		
		PACTROL P.C.B. No. 25B	1	079 716
16	386 802	Control thermostat ON / OFF switch.	1	004 882
17	308 285	Pressure switch, BECK 911 . 81 L	1	137 990
18	397 910	Control thermostat potentiometer.	1	137 661
18 A	308 357	Control thermostat sensor lead.	1	137 658
18 B	308 283	Control thermostat knob.	1	079 601
20	386 675	Overheat thermostat, RANCO LM 7.	1	589 930 056
21	386 686	Fan assembly.		
		SIFAN FFB 0224 - 004 or SEL RL 108/0034 - 3030 L.H.	1	136 728
26		Boiler casing assembly - white stove enamel, with sightglass, foil insulation & bottom panel (less glass fascia).		
	308 372	Ideal Elan 2 NF 230, NF 240, NF 250 & NF 260.	1	198 934 035
	308 408	Ideal Elan 2 NF 280.	1	137 989
27		Controls casing bottom panel.		
	308 373	Ideal Elan 2 NF 230, NF 240, NF 250 & NF 260.	1	079 612
	308 409	Ideal Elan 2 NF 280.	1	079 613
28	308 374	Glass fascia. Ideal Elan 2 NF 230, NF 240, NF 250 & NF 260.	1	137 900
	308 383	Ideal Elan 2 NF 280.	1	137 904
30	308 058	Casing seal. Ideal Elan 2 NF 230, NF 240, NF 250 & NF 260.	1	079 532
	308 059	Ideal Elan 2 NF 280.	1	079 533

28 SHORT PARTS

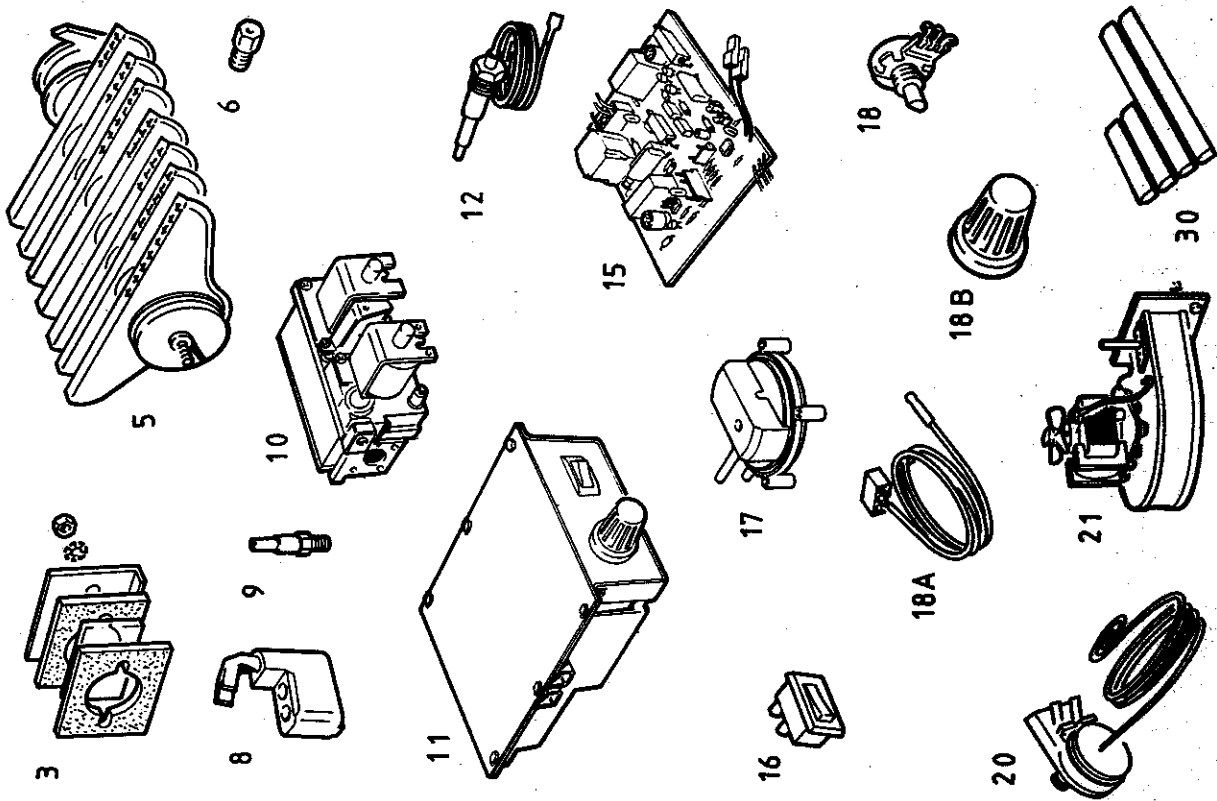

29 BOILER CASING ASSEMBLY

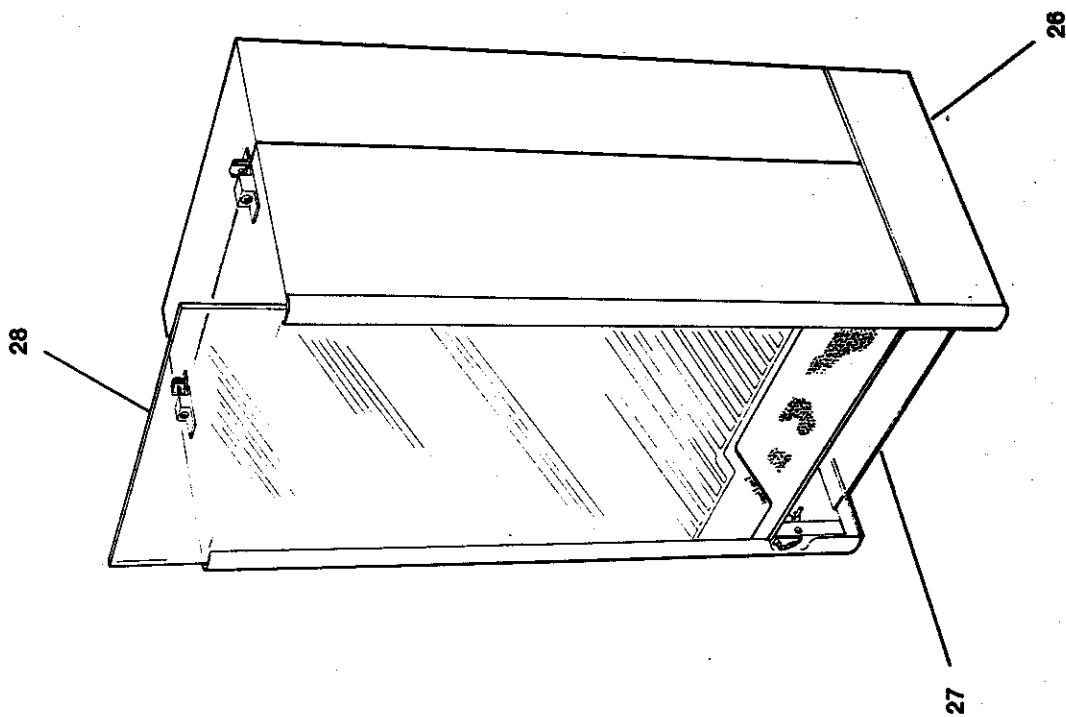



**THIS SYMBOL IS YOUR
ASSURANCE OF QUALITY**

These appliances are designed for use with Natural Gas only. They have been tested and conform with the provisions of BS. 6332 and BS. 5258.

Products bearing this Kitemark are made to a safety and performance standard under a stringent scheme of supervision and control monitored by the British Standards Institute.

CARADON IDEAL Ltd. pursues a policy of continuing improvement in the design and performance of its products. The right is therefore reserved to vary specification without notice.

CARADON IDEAL Ltd.

P.O. Box 103, National Avenue,

Kingston upon Hull,

North Humberside. HU5 4JN.

Telephone: 01482 492 251

Fax: 01482 448 858.

Registration No. London 322 137.

Registered Office; National Avenue, Kingston upon Hull,

North Humberside, HU5 4JN.

A subsidiary of Caradon p.l.c

August 1994 116-799 A07

BOILERS
Ideal

Customer Care & Technical Support

Please use the following numbers for speedy assistance.

Spares Tel: 01482 498 643

**Customer Care &
Technical Support** Tel: 01482 498 610

..... Fax: 01482 498 666

Publications/literature Tel: 01482 498 467