

PROVISIONAL COPY

Grant Grid-Connected Inverter

For Grant Solar PV Systems

Installation & User Instructions



Contents

1	Introduction & General Requirements	3
1.1	Installation Requirements	3
1.2	Signs used in this manual	3
1.3	Safety instructions	3
1.4	Disposal information	3
2	Product information	4
2.1	Product description	4
2.2	Technical specification	5
3	System Design	6
3.1	Guidance	6
4	Installation	7
4.1	Siting	7
4.2	Mounting	8
4.3	Electrical wiring	9
4.4	Energising the system	10
4.5	De-energising the system	10
5	Inverter Display and Indicators	11
5.1	LED indicators	11
5.2	LCD panel	11
5.3	Normal operation	12
5.4	System operating modes	13
5.5	Fault displays	14
5.6	Power generation data	15
6	Fault Finding	16
6.1	Grid volt error	16
6.2	TVS/Over power	16
6.3	DC supply issue	16
6.4	Inverter defect	16
7	Warranty information	17
7.1	Grant Grid Connected Inverter Warranty	17
8	Notes	18/19

1 Introduction & General Requirements

1.1 Installation Requirements

Thank you for purchasing a Grant grid-connected Inverter from our Solar PV Range. This installation manual must be read carefully before you begin installing the inverter.

This inverter must be installed by a competent person in compliance with all current legislation, codes of practice and local by-laws covering the installation of electrical equipment. Please also make sure that any installation complies with the instructions contained in this installation instruction manual.

1.2 Signs used in this manual



WARNING - This sign indicates that the following instructions must be read and complied with. Failure to do so may result in Fire, Injury and death.



CAUTION - This sign indicates that the following instructions must be read and complied with. Failure to do so may result in damage to property.

1.3 Safety instructions

All electrical installations must be carried out in accordance with the Electricity at Work Regulations 1989 and BS. 7671:2008 – IEE Wiring Regulations 17th Edition (including any amendments).

Isolate and disconnect both the AC and the DC connections to this inverter before commencing any maintenance. High power capacitors inside the inverter may be storing high voltages even with the AC/DC connections isolated.

The inverter must be mounted onto a solid fire resistant wall. The inverter weighs between 22.5 and 42.5kg (depending on the model) and will require two people to lift it into position.

Do not touch any part of the inverter whilst in operation as the casing temperature may exceed 60°C.

Do not disconnect the AC or the DC plugs from the inverter unless power has been removed from both the AC and DC sides. Doing so will damage the inverter and may result in electrocution.

1.4 Disposal information

Waste Electrical and Electronic Equipment (WEEE) & Restriction of the Use of Certain Hazardous



Substances in Electrical and Electronic Equipment (RoHS) Directives. The Waste Electrical and Electronic Equipment Directive (WEEE) is an EU initiative to protect the environment by reducing the amount of electrical equipment including PCs, servers, printers, laptops and other electrical products going into landfill sites.

This product is classed as Electrical and Electronic Equipment (EEE) and should not be disposed of with your general waste.

Please leave this manual with the householder after installation.

2 Product Information

2.1 Product Description

The Grant range of PV grid-connected inverters are designed for small to medium power grid-connected PV generation systems.

Features of the Grant inverter range include:

- * Sealed stainless steel enclosure designed and certified for IP65 protection.
- * Isolation transformer for safety and reliability without compromising conversion efficiency
- * Plug-in connections for AC , DC and communication (optional accessory) cables.
- * Power size and input voltage range for each input MPPT channel
- * Transient voltage suppressor at both input and output terminals to protect the inverter from transient high voltages induced by lightening or other sources.



2.2 Technical Specification

Input	Grant AS 1.0	Grant AS 1.5	Grant AS 2.0	Grant AS 3.0
	GPVX01010/AS	GPVX01015/AS	GPVX01020/AS	GPVX01030/AS
Recommended Input PV Power (W)	1250	1875	2500	3500
Max DC input power (W)	1200	1755	2350	3270
Nom. Input Voltage (Voc)	280	280	280	280
MPPT Voltage Range (Vdc)	150-400	150-400	150-400	150-400
Max. Voltage Range (V)	400	400	400	400
Max. Input DC Current (Adc)	6	10	6+6	10+10
Number of Input connections (pair)	1	1	2	2
Number of MPPT Channel	1	1	2	2
Input Transient Voltage Suppression	yes	yes	yes	yes
Earth Fault Detection and Indication	yes	yes	yes	yes
Opposite Polarity Protection	yes	yes	yes	yes

Output				
Max. Output AC (VA)	1100	1650	2200	3080
Nom. Output AC Power (VA)	1000	1500	2000	2800
Power Factor	>0.99	>0.99	>0.99	>0.99
Output Current THD	<4%	<4%	<4%	<4%
Nom. Grid Voltage (Vrms)	220-240V	220-240V	220-240V	220-240V
Rated Output AC Current (A)	4.3	6.5	8.7	13
Max. Output AC Current (A)	5	7	10	15
Grid Frequency Range (Hz)	50	50	50	50
Transformer Isolation	Yes	Yes	Yes	Yes
Output Transient Voltage Suppression	Yes	Yes	Yes	Yes
Anti-Islanding	Yes	Yes	Yes	Yes
Electromagnetic Compatibility	Yes	Yes	Yes	Yes
G83 Compatibility	Yes	Yes	Yes	Yes

Power Efficiency (with isolation)				
Max Efficiency	>93.5%	>94%	>94%	>94.5%
European Efficiency	>91.5%	>92%	>92.5%	>93%

Packaging				
Enclosure	IP65	IP65	IP65	IP65
Weight (kg)	22.5	27	36.5	42.5
Dimensions (HxWxD) mm	326x375x205	344x415x205	370x525x225	370x525x225

Environment				
Operation Ambient Temperature (8°C)	-25 - +50	-25 - +50	-25 - +50	-25 - +50
Storage Ambient Temperature (8°C)	-40 - +70	-40 - +70	-40 - +70	-40 - +70
Elevated above Sea Level (m)	4000 @ max. 30C	4000 @ max. 30C	4000 @ max. 30C	4000 @ max. 30C

3 System Design

3.1 Guidance

Incorrect system design could cause damage to the inverter.

Non-optimal design will lower the efficiency of the system and waste inverter power capacity.

A guide matrix is provided below for each inverter model when using the Grant GPV180M Solar PV modules.



CAUTION:

On no account must these values be exceeded.

GPVX01010/AS			GPVX01015/AS			GPVX01020/AS			GPVX01030/AS		
AS 1.0			AS 1.5			AS 2.0			AS 3.0		
No of Strings	Min modules per string	Max modules per string	No of strings	Min modules per string	Max modules per string	No of strings	Min modules per string	Max modules per string	No of strings	Min modules per string	Max modules per string
1	5	6	1	5	8	2	5	6	2	5	8

4 Installation

4.1 Siting

The Grant range of inverters can be installed either indoors or outdoors.

When siting the inverter, ensure that:

- 1) Sunlight cannot fall directly onto the inverter enclosure.
- 2) The inverter is installed on a concrete or brick wall.
- 3) The wall will not have a tilt angle greater than 30°.

The inverter should be mounted a minimum of 1.2m from ground level.

There must be a minimum space of 500mm above the top of the inverter and 200mm on both sides – Figure 1.



CAUTION:

Do not install the inverter in an explosive or flammable environment.



WARNING:

The inverter must not be covered or partially covered at any time, due to risk of fire!

The site of the installation will be dry, clean from dust and sufficient room to allow free air to circulate.



CAUTION:

The site of the installation should not be an area that is in constant use by people or animals. Do not touch the enclosure while the inverter is in operation. The temperature of the casing may exceed 60°C. Risk of burns.

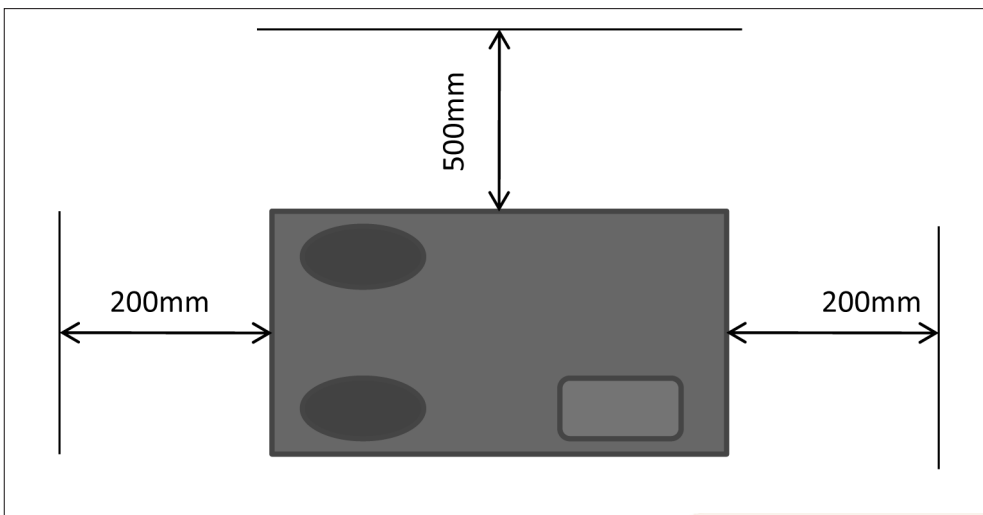

Figure 1: Clearances around inverter, viewed from the front.

4 Installation continued...

4.2 Mounting

Using the two holes on the mounting bracket as a guide, mark and drill two 12mm holes.

Assemble the expansion bolt set as shown in Figure 2, and secure the mounting plate to the wall.

Lift the inverter (with two people) and hang on the top edge of the mounting plate.

Fix the positioning bolt to the bottom hole of the mounting bracket.

Fasten the positioning bolt under the inverter. See Figure 3



WARNING:
The inverter must not be installed on a flammable surface, due to risk of fire!

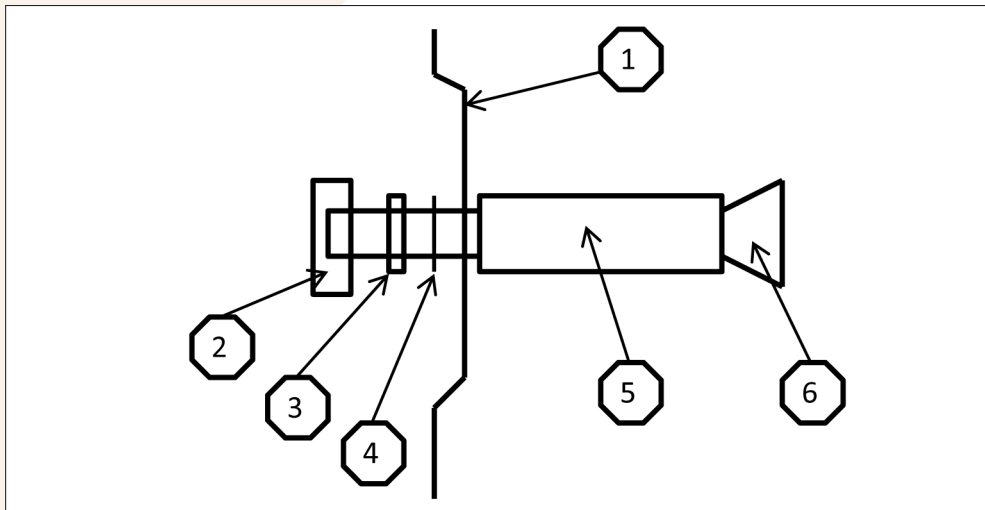

- 1) Mounting Bracket
- 2) Nut
- 3) Spring washer
- 4) Flat washer
- 5) Expansion tube
- 6) Bolt

Figure 2: Bolt Assembly

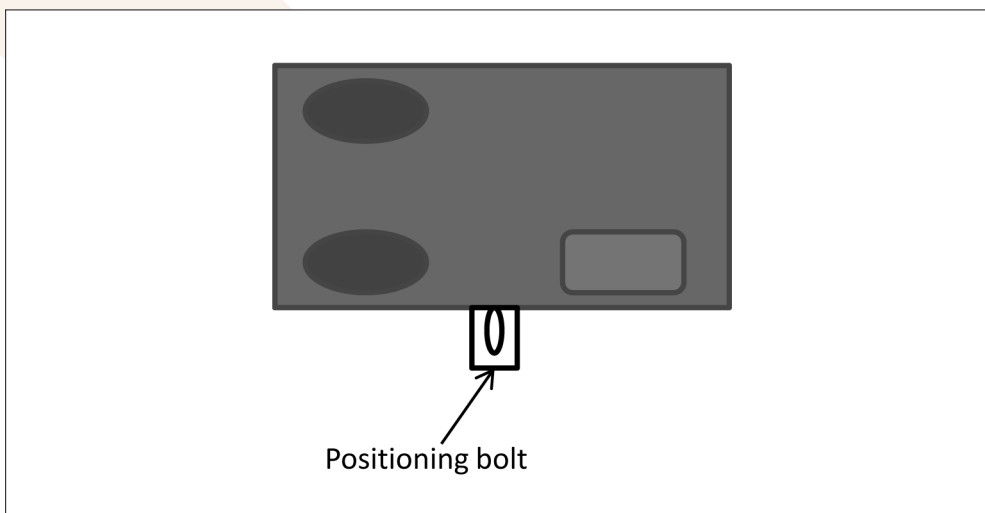

Figure 3: Bolt Positioning

4.3 Electrical wiring

Before connecting the AC and DC cables to the inverter, check the data plate on the inverter matches the installation requirements for both AC and DC. (Voltage, power, frequency, etc). **Failure to do so could damage the inverter or cause a malfunction during operation.**

The Grant range of inverters are designed only for Solar PV Grid-Connected installations only. It is forbidden to connect this inverter to a public DC network or an island (battery) system.

Only Grant Solar PV modules (GPV180M) are permitted to be fitted to this inverter. Do not connect any other type of DC generating device to this inverter.

DC CONNECTION

The length of the cable between the PV array and the inverter should not exceed 10m. This includes any DC isolators that are fitted between the array and the inverter.

Longer cables could lower the overall system efficiency and could cause electromagnetic interference.

* The inverter uses a MC Type4 DC plug and socket for connecting the PV array cables.

* The cross section of the cable must not be less than 4mm².

* The DC array cable must be rated for 1000VDC

AC CONNECTION

The flex used for each inverter is as follows:

* For Grant AS1.0 and AS1.5 inverters, heat resistant 1.5mm² flex must be used.

* For AS2.0 and AS3.0 inverters, heat resistant 2.5mm² flex must be used.

The connection of the wires to the AC plug is shown on Figure 4.

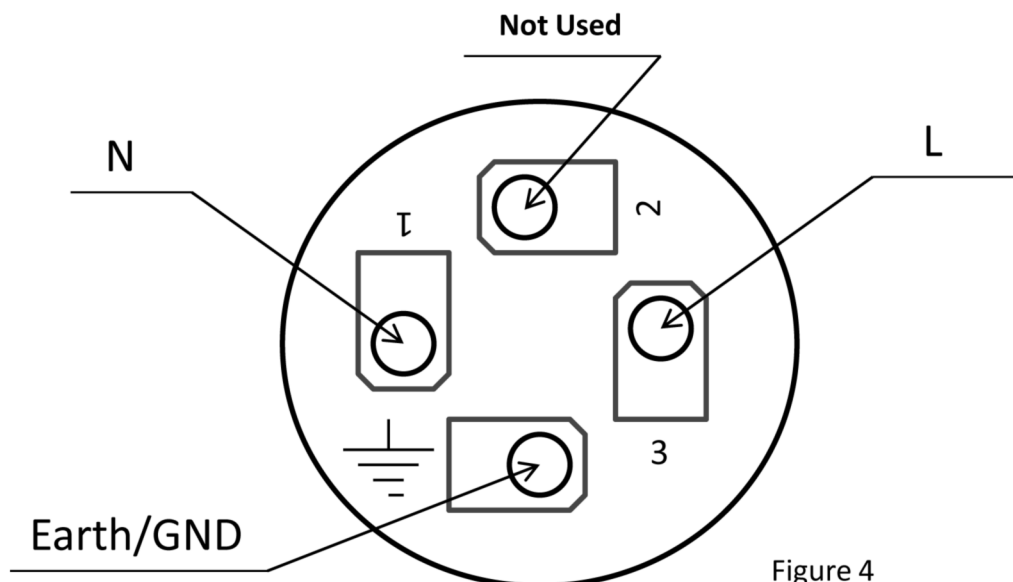

Figure 4

Figure 4: AC Plug Wiring diagram

4 Installation continued...

4.4 Energising the system



CAUTION

Check that the voltage of the completed PV string does not exceed 400V and note the polarity of the MC4 connectors is correct.

Check the AC isolator(s) are in the 'off' position and that there is no power being supplied to the inverter.

Connect the AC plug to the inverter and screw the securing ring hand tight. Isolate the DC isolator(s). Connect the MC Type4 connectors to the inverter. Turn on the DC isolator(s). Note that the LCD display on the inverter reads 'Grid Volt Error – Grid Frequency Error'.

Turn on the AC isolator(s). The inverter now takes approximately 1 minute to carry out self-diagnostic checks on the DC and AC conditions. Check the operation status by scrolling through the LCD displays one by one. Make sure the system is now in normal operation mode.

For references to the LCD display see section 4.

4.5 De-energising the system

Irrespective what condition the inverter is in, carry out the following instructions in the order they appear to safely isolate the inverter.

Turn off and lock off the DC isolator(s).
Turn off and lock off the AC isolator(s).

If maintenance on the DC side is required, disconnect the DC MC Type4 plugs from the inverter. If maintenance on the AC side of the inverter is required, disconnect the DC MC Type4 plugs and then disconnect the AC plug from the inverter.

5 Inverter Display and Indicators

5.1 LED indicators

As shown in Figure 5, there are 3 indicator LED's on the front panel of the inverter. These LED's indicate Power, Run and Fault. When the system is energised, the power LED is lit (green), otherwise it is unlit.

When the system is operating normally, and is generating power, the run LED is lit (green), otherwise it remains unlit.

When the system develops a fault, the Fault LED lights one of two colours to indicate a fault. A Red LED indicates a category 1 fault; a green LED indicates a category 2 fault.

When the fault is removed, this LED turns off.

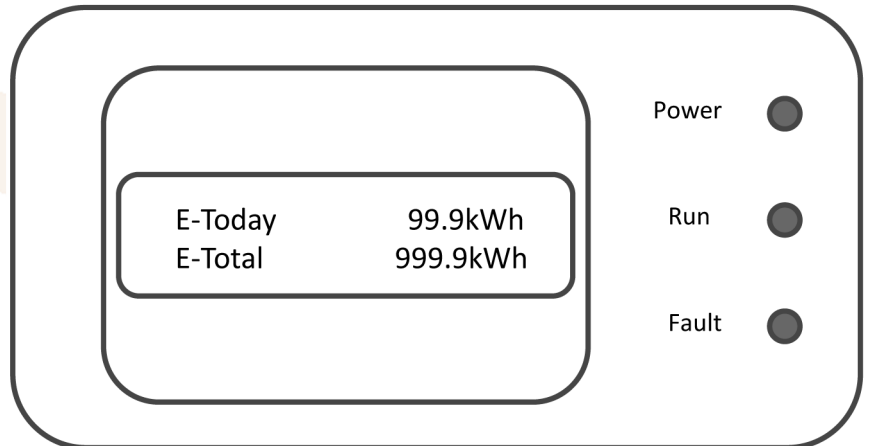

Figure 5: Indicator LED's

5.2 LCD Panel

The LCD shows two lines of information. By touching the case of the inverter, the display will be backlit for a period of 30 seconds.

The display screen can display 3 categories of information – system initialisation; normal operation and system operating mode including the fault categories.

When the system is energised, the LCD module will start Initialisation. See figure 6 for start sequence display.

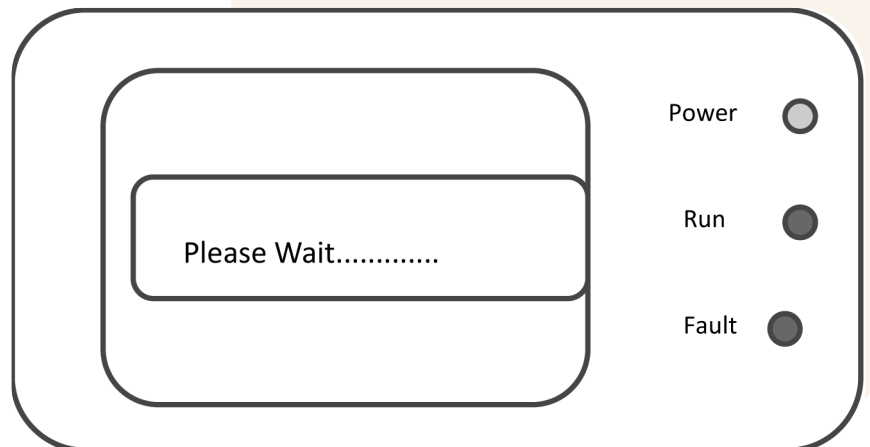

Figure 6: Start sequence display

5 Inverter Display and Indicators continued...

5.3 Normal operation

Information of normal operation is split into groups of Operating Status; Statistical Information and Operating Mode Information.

The Operating status is used to display the main operating parameters of the inverter. The Statistical Information parameter shows total operating time, daily generation and total power generation . The information is displayed on a rolling mode with an interval of 5 seconds.

When the system is powered on, the LCD module begins initialising and will show a display similar to Figure 7.

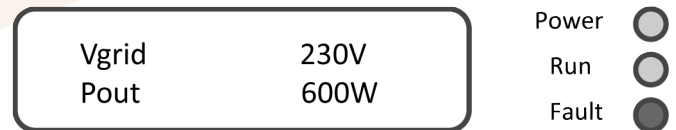

Figure 7: Display

After a few seconds, the system will enter the rolling sequence of operating information. See Figure 8:

Vgrid: Value range 0 to 499 V (volts)

Pout: Value range 0 to 9999 W (Watts)

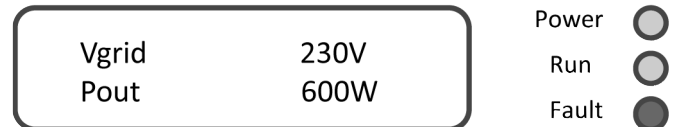

Figure 8: Display

For 2-string inverters where only one string is used, the unused channel may show a small residual voltage. This is normal. See Figure 9

Vpv1 (Voltage of PV string 1)

Value range 0 to 499V (volts)

Vpv2 (Voltage of PV string 2)

Value range 0 to 499V (volts)

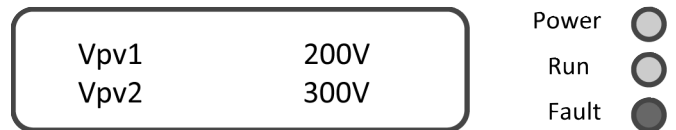

Figure 9: Display

See Figure 10.

E-Today (Power generated today) in kWh

Range: 0 to 99.9 kWh

E-Total (Power generated in total) in kWh

Range: 0 to 300,000 kWh

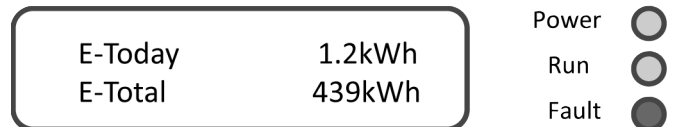

Figure 10: Display

See Figure 11.

T-Today (generation time today)

Range: 0.0 to 24.0 h (hours)

T-Total (Total generation time)

Range: 0.0 to 99,999 h (hours)

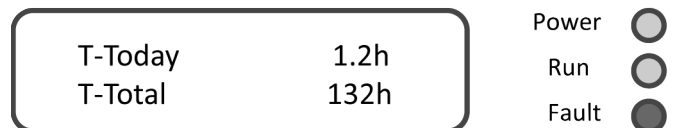

Figure 11: Display

Internal Temp of the Inverter See Figure 12.

Value: 0 to 99 °C

Mode is used to indicate what operating mode the inverter is currently in.

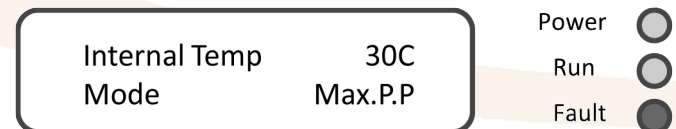

Figure 12: Display

Display real time: Year/Month/Date/Hour/Minute See Figure 13.

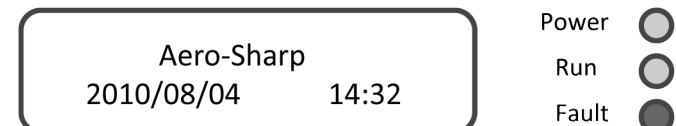

Figure 13: Display

5.4 System operating modes

There are 4 operating modes as follows:

1) STAND-BY MODE

The system is energised but hasn't met the requirements to generate power (too little sunlight/small DC voltage) or the equipment has not entered generation status after restart. See Figure 14.

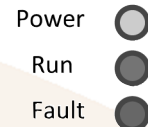
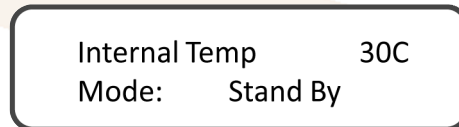

Figure 14: Stand-by mode

2) INTERRUPTED MODE

The system has shut down because of CAT 1 (see info below). See Figure 15.

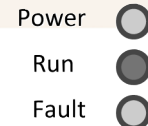

Figure 15: Interrupted mode

3) POWER-LIMITING MODE

The system reduces power output when overheated or Overloaded. See Figure 16.

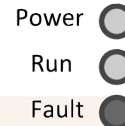
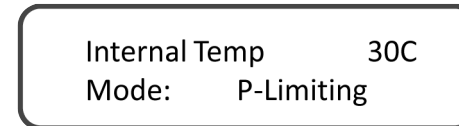

Figure 16: Power-limiting mode

4) MAXIMUM POWER POINT MODE

The system is operating at maximum power See Figure 17.

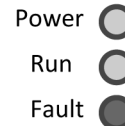
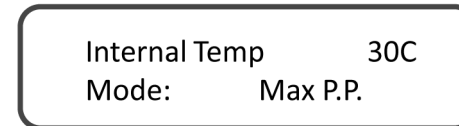

Figure 17 Maximum power point mode

5 Inverter Display and Indicators continued...

5.5 Fault Displays

Faults are divided into 2 categories. CAT1 and CAT2.

CAT1 Fault

There are 5 types of fault:

1. BIT Failure
2. Ground Failure
3. PV1 Over Voltage
4. PV2 Over Voltage
5. System Error

The system will restore normal operating after the CAT1 fault is cleared. If this fault continuously occurs, the system

Will shut down and will require the complete system to be examined by a qualified engineer.

CAT2 Fault

There are 5 types of fault:

1. PV over Power
2. Grid Volt Error
3. Grid Frequency Error
4. TVS1 Failure
5. TVS2 Failure

There will be 2 lines of information displayed. The top line will display the fault information.

If there is more than one fault, the display will roll with intervals of 5 seconds.

The bottom line will display information of the operating status and statistics. The display will roll with intervals of 5 seconds.

If faults 1, 4 or 5 occur, the system will operate normally but it is advised that all TVS are replaced as soon as possible by a qualified engineer.

If faults 2 or 3 occur the system will stop operating. The system will start automatically if the grid connection returns to a normal condition.

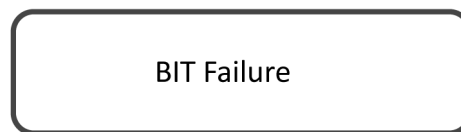

Figure 18: CAT1 Display

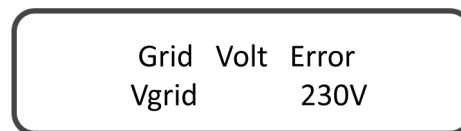
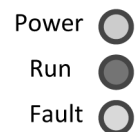

Figure 19: CAT2 Display



Grid Volt Error
Pout: Range 0 to 3999W



Power
Run
Fault (green)

Figure 20: CAT2 Display

Grid Volt Error
Vpv1: Range 0 to 499V

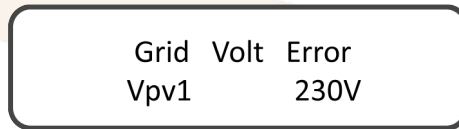

Power
Run
Fault (green)

Figure 21: CAT2 Display

Grid Volt Error
Vpv2: Range 0 to 499V

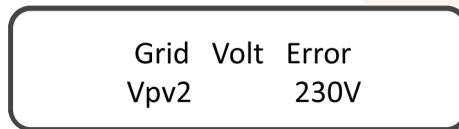

Power
Run
Fault (green)

Figure 22: CAT2 Display

Grid Volt Error
E-Today: Range 0.0 to 99.9kWh

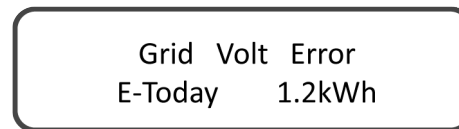

Power
Run
Fault (green)

Figure 23: CAT2 Display

Grid Volt Error
E-Total: Range 0 to 300,000 kWh

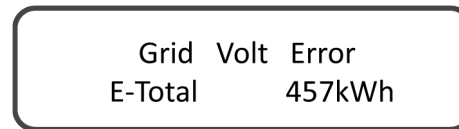

Power
Run
Fault (green)

Figure 24: CAT2 Display

Grid Volt Error
T-Total: Range 0.0 to 24.0h

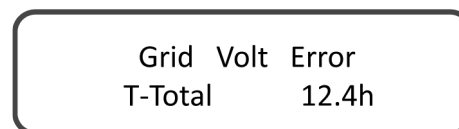

Power
Run
Fault (green)

Figure 25: CAT2 Display

Grid Volt Error
Internal Temp: Range 0 to 99C

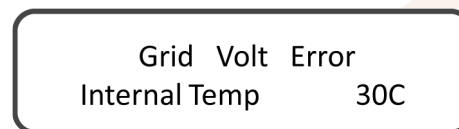

Power
Run
Fault (green)

Figure 26: CAT2 Display

5.6 Power Generation Data

In addition to the system operating condition, the inverter also records power output for all conditions including daily output for the last 30 days and monthly outputs for the last 12 months. The system can record up to 1000 records of fault information which includes fault characters to a maximum of 10 digits. When the records exceed 1000, the oldest record will be replaced. All of the above operating information and records can be read via the optional communication kit.

6 Fault finding

6.1 Grid Volt Error

Possible causes:

- 1) Grid supply is under or over voltage.
- 2) Grid frequency is lower/higher than allowed
- 3) Grid connection error (no Live and/or Neutral).

Solutions:

- 1) Check supply voltages to consumer unit
- 2) Check frequency of power supply at consumer unit
- 3) Check compatibility of inverter for power supply being used.

6.2 TVS/Over Power

Possible causes:

- 1) TVS component failure
- 2) System Overload

Solutions:

- 1) Contact Grant Engineering Service department to arrange for the replacement of the TVS components when the display reads 'TVS1 or TVS2 failure'.
- 2) If the display reads 'PV Over Power', check the PV configuration and check for inverter compatibility.

6.3 DC Supply Issue

Possible causes:

- 1) DC input over or under Voltage

Solutions:

- 1) Isolate the inverter and check the Strings for over/under voltage.
- 2) Check this measurement with the aid of an irradiance meter. (Optional equipment from Grant Engineering.)



WARNING

There are no user-serviceable components inside the Grant grid connected inverter.

Service and repair of the unit can only be carried out by Grant Engineering or a trained Grant representative, due to a high risk of electric shock!

6.4 Inverter Defect

Possible causes:

- 1) Internal errors including power components, over power condition, other system errors.

Solutions:

- 1) Turn DC isolators off, turn AC isolators off and wait for 10 minutes. Check AC voltage supply and if all is well, restart the inverter normally.
- 2) If the systems fails to operate normally, shut down the system and contact the system installer.

7 Warranty information

7.1 Grant Grid Connected Inverter Warranty

Dear Customer

This product is guaranteed for ten years from the Date of Purchase (subject to the terms and conditions stated below).

On completion of the installation, the system should be commissioned and registered online at: www.grantuk.com

Breakdown during the Manufacturer's warranty.

If your Grant Solar PV Grid Inverter should fail within the first ten years* of the date of purchase you must contact Grant Engineering (UK) Limited, who will arrange for the repair under the terms of their Warranty, providing that the inverter has been correctly installed and commissioned, and the fault is not due to misuse, or the failure of any system components not supplied by Grant UK (e.g. circuit breakers, AC cabling, etc.), any fault in the existing electrical installation or the incorrect setting of the system controls.

Chargeable repairs

A charge will be made if the cause of the breakdown is due to any of the following:

- The inverter has been installed for over ten years
- The inverter is damaged by improper installation, usage, connection.
- The inverter has not been installed in accordance with the manufacturers installation instructions.
- The inverter has been changed, modified or repair attempts have been made by unauthorised personnel
- The inverter has been damaged in transit
- Where the inverter data plate is missing or has been tampered with
- Where unauthorised accessories have been used
- Incorrect PV system design resulting in Over Voltage or Over Power.
- Force Majeure –lightning, earthquake, flood, fire etc.*

Terms of manufacturer's guarantee

The Grant Solar PV Grid Inverter guarantee starts from the date of purchase.

- This guarantee does not cover breakdowns caused by incorrect installation, neglect, misuse, accident or failure to operate the system in accordance with these Installation and User Instructions.
- The online registration must be completed within thirty days of installation. Failure to do so does not affect your statutoryrights.
- The Grant Solar PV System must be installed by a competent installer in accordance with the relevant Codes of Practice, Regulations and Legislation in force at the time of installation.
- The Grant Solar PV Inverter components must not have been modified or tampered with.
- The installation is checked by a qualified electrician every ten years, or sooner, as required by the current BS.7671 (WiringRegulations –17th Edition).
- All claims under this guarantee must be made to Grant Engineering (UK) Ltd prior to any work being undertaken. Proof of purchase and date of installation must be provided on request. Invoices for call out/repair work by any third party will not be accepted unless previously authorisedby Grant Engineering (UK) Ltd.
- This guarantee is transferable providing the installation is serviced prior to the dwelling's new owners taking up residence.Grant Engineering (UK) Ltd must be informed of the new owner's details.
- Grant Engineering (UK) Ltd will endeavour to provide prompt service in the unlikely event of a problem occurring, but cannot beheld responsible for any consequence of delay however caused.
- This guarantee applies to Grant Solar PV Inverters installed on the UK mainland, Isle of Man and Channel Islands only. Provision of in-warranty cover elsewhere in the UK is subject to agreement with Grant Engineering (UK) Ltd.

Notes

Notes



GRANT ENGINEERING (UK) LTD

Hopton House, Hopton Industrial Estate, Devizes, Wiltshire. SN10 2EU
Telephone: 01380 736920 Fax: 01380 736991
Email: info@grantuk.com Website: www.grantuk.com