

GRANT CONDENSING RANGE



Internal and External Oil-Fired Condensing Boilers with Outputs from 12kW to 70kW



FEATURES:

Grant Vortex Eco Range

Floor standing utility and external models in standard and system versions.

Wall hung utility and external models in standard and system versions.

Grant Vortex Pro Range

Floor standing kitchen/utility and external models in standard, system and combination versions.

Energy Management Controls

Grant Efficiency Optimiser



Grant Profile

The Company

With an established history of over 30 years designing, manufacturing and supplying a wide range of highly efficient and reliable products, Grant has become a firm favourite for many heating engineers and householders when choosing a new or replacement oil-fired boiler.

The Company has achieved an enviable reputation within the heating industry for its approach to new concepts like condensing technology. Today, Grant's range of Vortex oil-fired condensing boilers tops the Government SEDBUK Efficiency Database and is the market leading product in this sector

Endorsed at the highest level

Grant products and facilities have been endorsed at the highest level with the Grant Vortex range being named 'Domestic H&V Product of the Year 2003' and the Training Academy, winning 'Training Initiative of the Year 2004' both in the prestigious H&V News Awards for Excellence - known in the Trade as "The Oscars of the Heating Industry". Grant's training facilities were also acknowledged recently when they were awarded OFTEC Training Centre of the Year for the second time.



No other company in the domestic oil heating industry has ever received this level of recognition for product design, high quality engineering, innovation and training. It was also the first time in the history of the H&V News Awards for Excellence that an oil-fired boiler had won the coveted trophy.

Additionally, the Grant Vortex Combi Pro 26 has been awarded the prestigious 'Which? Best Buy' accreditation for 2008. The boiler survey gave the combi an outstanding 74% and mentioned it was their first ever oil 'Best Buy'.



A new approach to oil-fired heating

The name 'Grant' has in recent years become synonymous with highly efficient oil-fired central heating appliances. Designs like the 'Multi Pass' boiler achieved efficiency levels far in excess of any UK or European Standards and have helped thousands of homes to reduce their annual fuel bills. So it will come as no surprise to see Grant yet again leading the way with the Grant Vortex oil-fired condensing boiler range.

Quality design

Despite the sophisticated technology employed in the development of new products, Grant's design engineers have kept true to the original Grant concept of simplicity in installation and maintenance which are essential ingredients of today's heating systems. Grant products are manufactured from the highest quality materials and designed not just to meet, but to exceed all relevant performance and environmental standards.

Backed by highly efficient administration and Grant's comprehensive extended warranty schemes, the Company is also focused on providing an exceptional after sales service for its customers.

Why should you install an energy efficient boiler?

A great deal of media coverage has been given to global warming and the environmental damage caused by burning fossil fuels. There are many contributing factors, but one area that can make a significant difference and reduce the amount of harmful greenhouse gases in the atmosphere is to install a more efficient central heating boiler. Older oil-fired boilers, designed at a time when very little consideration was given to environmental issues, can operate with efficiency levels as low as 65%. A modern oil-fired condensing boiler, like the Grant



Vortex, has been tested and approved to operate at very high efficiency levels, achieving a considerable reduction in harmful emissions, whilst lowering annual fuel bills.



Grant Condensing Technology

Contents

What is a condensing boiler?

Condensing boilers differ from traditional boilers in that they are designed to capture heat normally lost through the flue system during the combustion process. Unlike traditional oil-fired boilers the Grant Vortex condensing boiler has a built-in stainless steel heat exchanger incorporating Grant's unique turbulator baffle system, which cools the gases to a point where the latent heat, normally lost to the atmosphere through the flue, can be usefully extracted. The additional energy recovered enables the boiler to operate continuously at much higher efficiency levels, resulting in lower heating and hot water running costs.

Typical annual running costs comparison*

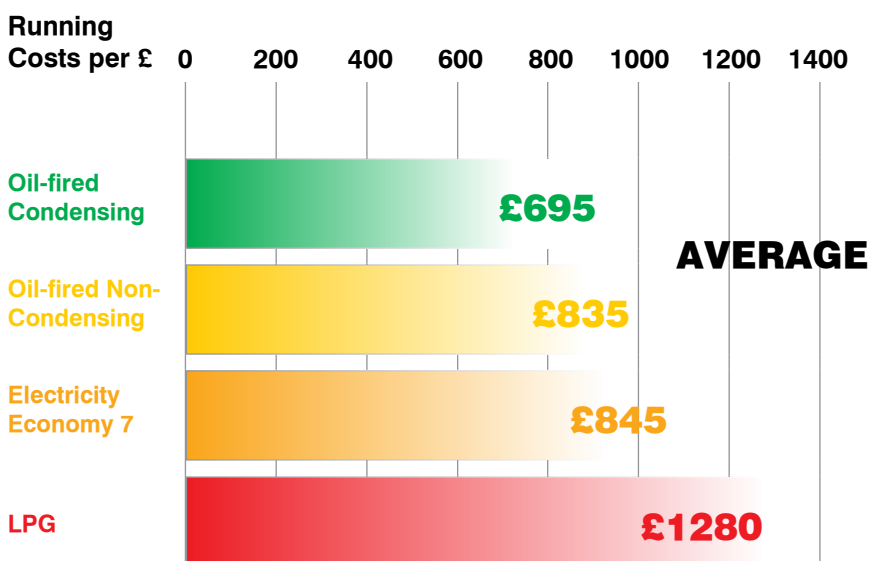

*Figures reproduced with kind permission from Sutherland Tables, showing a 5-year average running cost for a 3 bedroom house in the UK up until May 08.

EZ-Fit Flue Systems

All Grant boilers are supplied for connection to either a 'stainless steel' conventional flue, or one of Grant's EZ-Fit Flue options. The flue systems are available as low level, high level or vertical kits, for internal and external applications, and even as unique EZ-Flexi Packs, designed to enable condensing boilers to utilise an existing chimney.



Combining oil and renewable technologies

With constantly rising fuel costs, an ideal way to ensure your household is as energy efficient as possible would be to combine your new Grant oil-fired system with a renewable technology like Grant Solar Thermal. This easy to install option can provide up to 70% of your hot water needs and is the perfect match with oil-fired condensing boilers.

For details on all green Grant products including solar thermal, solar PV, air source heat pumps, cylinders, and Grant's unique GEO360 energy management control system visit: www.grantuk.com or alternatively call the Sales Department on: 01380 736920



2. Grant Company Profile

3. Grant Condensing Technology

4. Grant Vortex Eco Utility Range

6. Grant Vortex Eco Outdoor Range

8. Grant Vortex Eco Wall Hung Range

10. Grant Vortex Pro Kitchen/Utility Range

12. Grant Vortex Pro Outdoor Range

14. Grant Vortex Pro Combi Range

16. Energy Management Controls

19. General Information



Grant Vortex **Eco Utility** Range

Introduction

The Grant Vortex Eco Utility Range was launched as a direct response to customer demand for a competitively priced condensing boiler.

The Eco models incorporate the latest version of the Grant Vortex stainless steel heat exchanger. Outputs range between 15kW and 35kW (50-120,000Btu/h) with SAP 2009 gross seasonal efficiencies of 90.3 - 90.8% gross.

As you would expect from a product with this pedigree, Grant Vortex Eco Utility boilers are exceptionally quiet in operation and feature the latest Riello burner technology. The boilers also have a simplified casing, control panel and pipework arrangement, making them the ideal choice for utility room installations.

All standard Eco Utility boilers are designed to allow the burner and combustion chambers to be serviced from the front, however, models fitted with a sealed system kit require top service access.



Dimensions (mm)

Grant Vortex **Eco Utility** 15-21 and 21-26

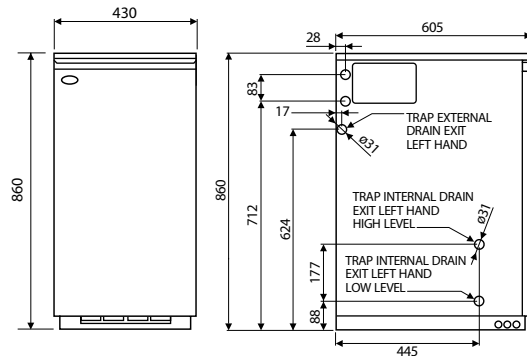

Grant Vortex **Eco Utility** 26-35

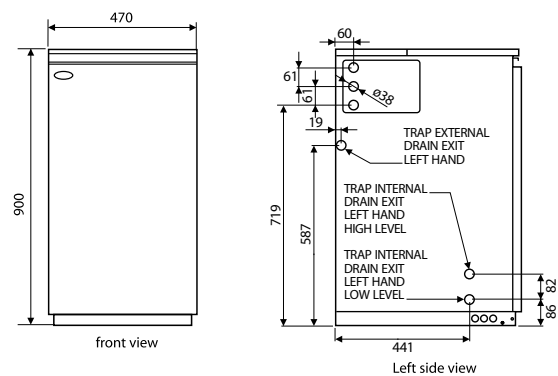

Condensate removal

The condensate trap is now factory fitted within the white case on Grant Vortex Eco Utility boilers, but can also be positioned externally if preferred.

Flueing

Utility models are compatible with all of Grant's EZ-Fit flue options and capable of being flued from the top, rear, left or right hand sides of the appliance.

Sealed system kits

Grant Vortex Eco Utility models can also be converted to sealed system operation, by adding a sealed system kit (Product code: VTXCOSKIT35). This optional pack fits all models and can be neatly housed within the boiler enclosure. It includes a filling loop, expansion vessel, pressure gauge and circulating pump.



Grant Vortex Eco Utility Models

VTXECO1521

VTXECO2126

VTXECO2635

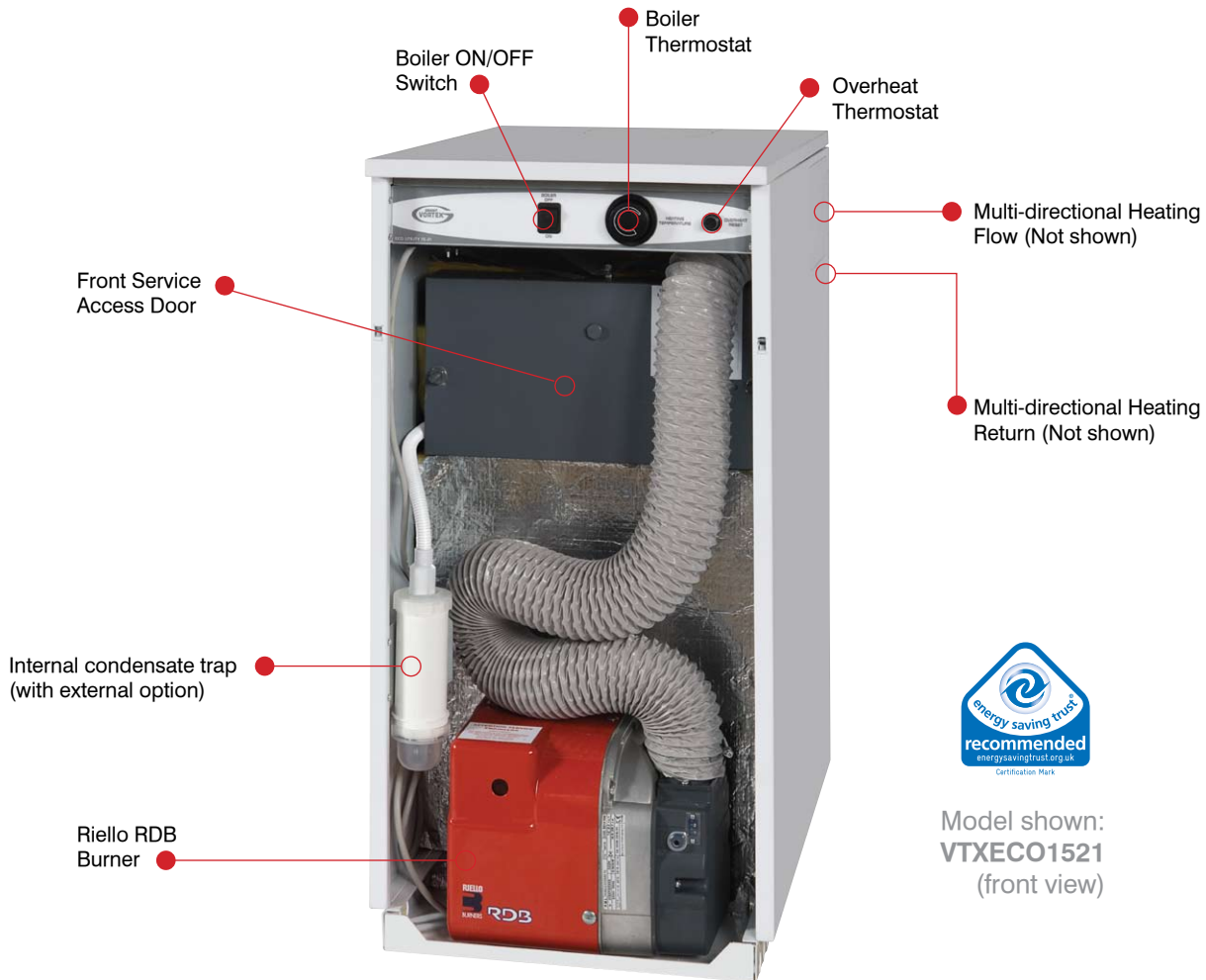

Model shown:
VTXECO1521
(front view)

Technical specifications

Model	Eco Utility Models		
	15-21	21-26	26-35
Output kW	15 to 21	21 to 26	26 to 35
Output Btu/h	50-70,000	70-90,000	90-120,000
Flow connection	22mm	22mm	22mm
Return connection	22mm	22mm	22mm
Cold water in (system kit)	15mm	15mm	15mm
Pressure relief (system kit)	15mm	15mm	15mm
Condensate pipe	21.5mm OD plastic overflow pipe		

NOTE 1: The boiler flow and return connections exit the casing on the left or right hand side.
NOTE 2: Grant Vortex Eco utility boilers are suitable for fully pumped systems only.

Vortex Eco
Wall-Mounted
Programmer Options



Optional Grant ES Kit,
Wall-mounted twin-channel
programmer



Optional Grant RS Kit Wall-mounted
programmable room thermostat

Grant Vortex **Eco Outdoor** Range

Introduction

Grant developed the first oil-fired external boiler in 1986 and although the concept was new to the oil market, it quickly became a popular addition to the range. Today, as around one in four oil boiler installations are external, Grant have expanded the number of options available with the launch of three competitively priced Eco external modules. The models have outputs between 15kW and 35kW (50-120,000Btu/h) and SAP 2009 gross seasonal efficiencies of 90.3 - 90.8% gross.

External finish

This high efficiency Eco external range has some unique features including multi-directional flueing options, high quality external powder coated paint finish, built-in boiler frost protection, mains isolating switch and a test switch.

Dimensions (mm)

Grant Vortex **Eco External** 15-21, 21-26, 26-35

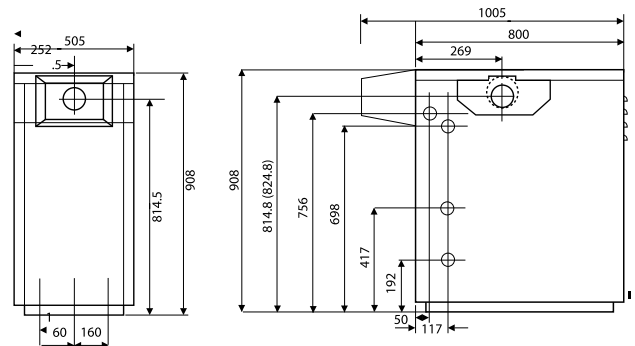

Sealed system kits

Eco external boilers can be converted to sealed system operation by purchasing a pre-assembled kit from Grant UK (Product code: VTXECOSSKIT35). The sealed system kit includes an expansion vessel, automatic air vent, pressure relief valve and circulating pump. A filling loop and pressure gauge are also supplied as part of the kit. These can be fitted within the module casing, or ideally in a convenient site within the building, located between the cold main and central heating return.



Model shown: Grant Vortex Eco External Module

Grant Vortex **Eco** External Modules

VTXOMECO1521

VTXOMECO2126

VTXOMECO2635

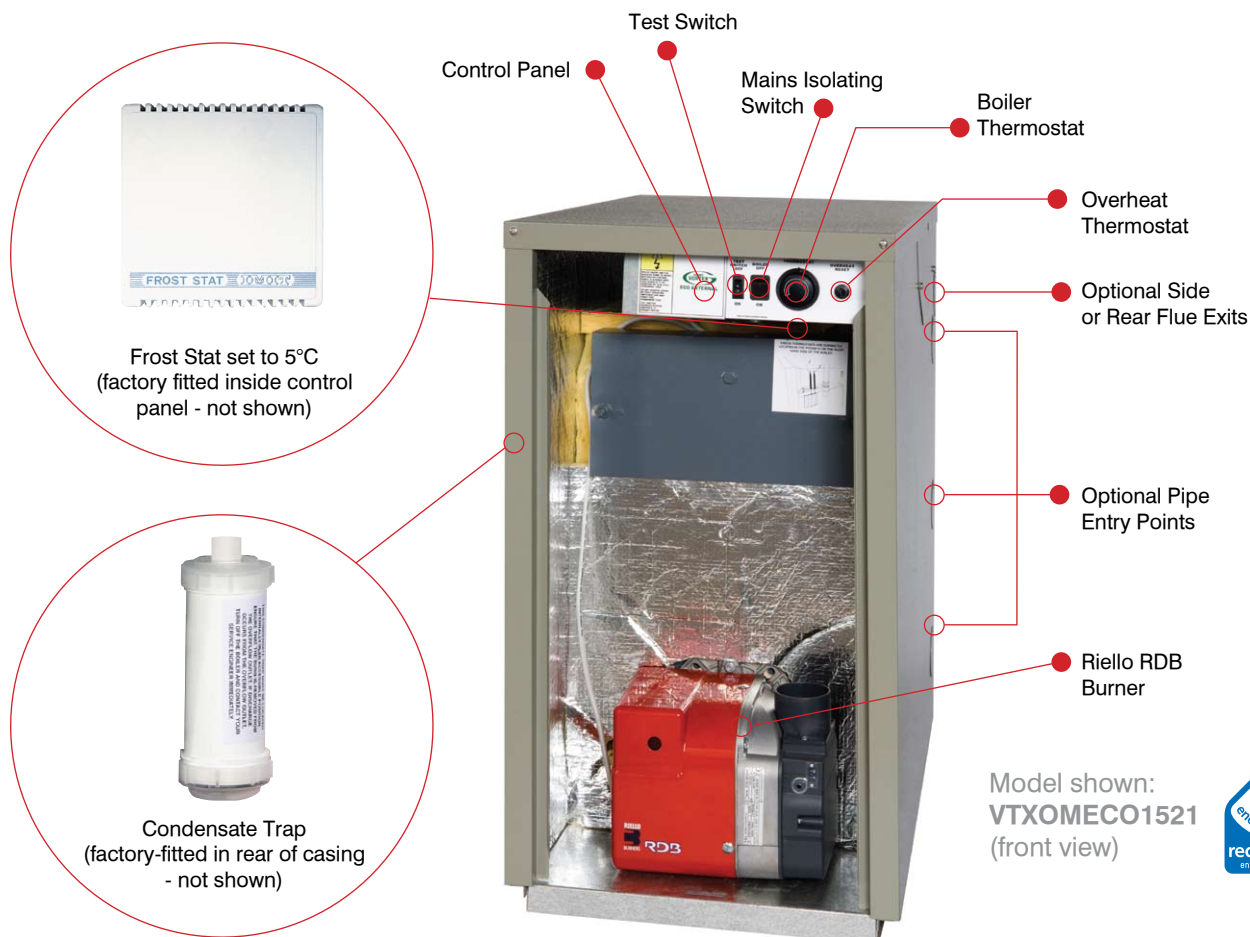

Technical specifications - Boiler Connections

Model	Eco External Modules		
	15-21	21-26	26-35
Output kW	15 to 21	21 to 26	26 to 35
Output Btu/h	50-70,000	70-90,000	90-120,000
Flow connection	22mm	22mm	22mm
Return connection	22mm	22mm	22mm
Cold water in (system kit)	15mm	15mm	15mm
Pressure relief (system kit)	15mm	15mm	15mm
Condensate pipe	21.5mm OD plastic overflow pipe		

NOTE 1: All boiler connections can be positioned to the left or right of the appliance.
NOTE 2: Grant Vortex Eco External Modules are suitable for fully pumped systems only.

Vortex Eco
Wall-Mounted
Programmer Options



Optional Grant ES Kit, Wall-mounted twin-channel programmer



Optional Grant RS Kit Wall-mounted programmable room thermostat

Grant Vortex **Eco Wall Hung** Range

Introduction

Grant's wall hung oil-fired boiler range comprises four internal and four external models.

Available in outputs ranging from 12-21kW, in both sealed system and open-vented system variants, these new appliances are pre plumbed and encompass Grant's patented Vortex stainless steel heat exchanger and turbulator baffle system.

All internal models require a separate flue kit (not supplied with the boiler) and are compatible with all Grant's EZ-Fit low level, high level and vertical flue systems, so now almost any installation situation can be catered for.

Unique External Modules

All Grant Vortex Eco External Wall Hung models come complete with a factory fitted flue, high quality external powder coated paint finish, built-in boiler frost protection, mains isolating switch and a test switch.

Sealed system models

Grant Vortex Eco Wall Hung boilers are also available in sealed system versions. These include a factory fitted expansion vessel, filling loop, pressure gauge, automatic air vent, pressure relief valve and circulating pump, enabling boilers to be installed without the need for a feed and expansion tank in the loft.

Dimensions (mm)

Grant Vortex Eco Wall Hung Internal 12-16, 16-21

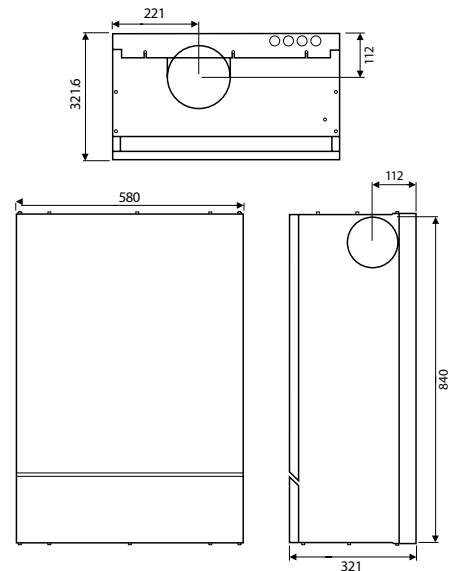

Grant Vortex Eco Wall Hung External 12-16, 16-21

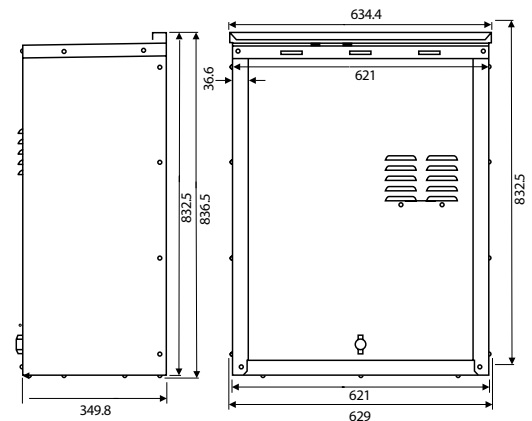

Grant Vortex **Eco** Internal/Internal System
Wall Hung Models

Grant Vortex **Eco** External/External System
Wall Hung Models

- VTXWH1216
- VTXWH1621
- VTXSWH1216
- VTXSWH1621

- VTXOMWH1216
- VTXOMWH1621
- VTXSOMWH1216
- VTXSOMWH1621

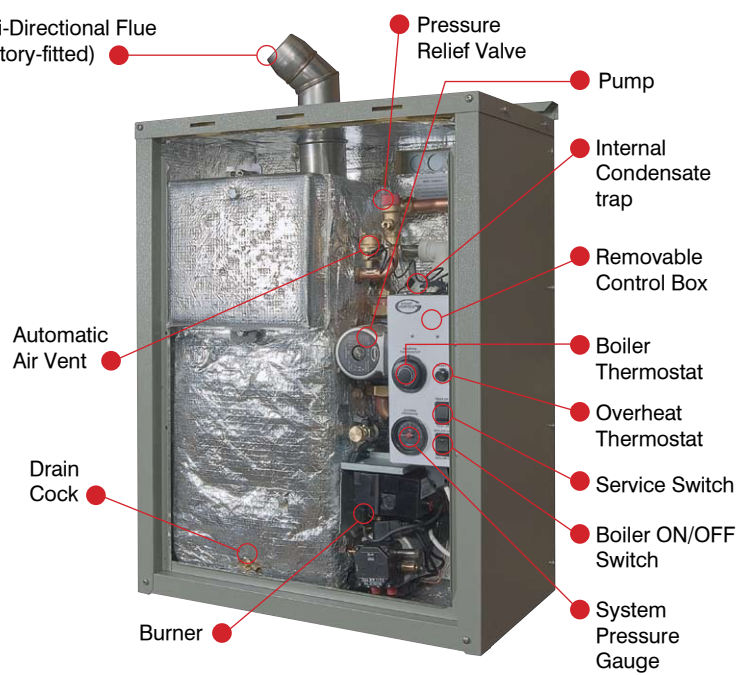
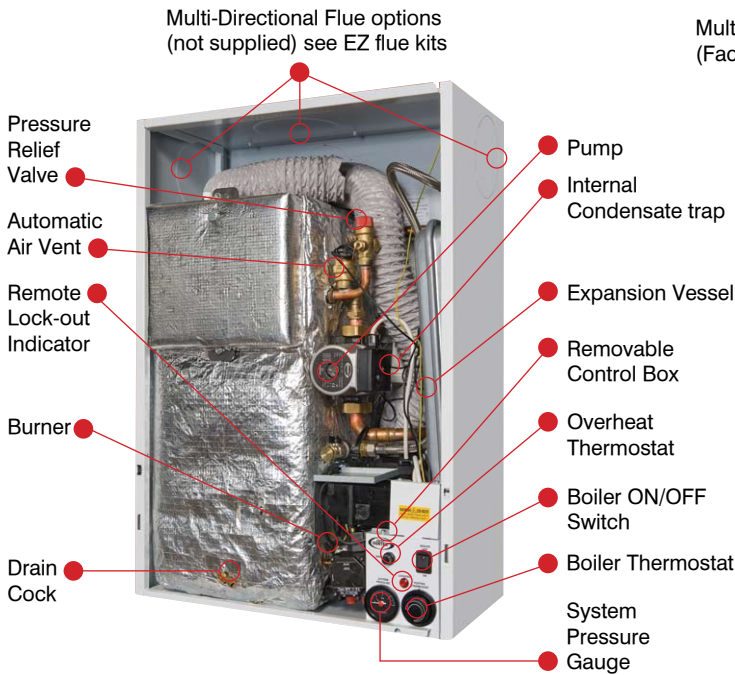

Model shown
VTXSWH1216 (front view)



Model shown
VTXSOMWH1216 (front view)

Technical specifications - Boiler Connections

Model	Internal Models		Internal System Models		External Modules		External System Modules	
	12-16	16-21	12-16	16-21	12-16	16-21	12-16	16-21
Output kW	12 to 16	16 to 21	12 to 16	16 to 21	12 to 16	16 to 21	12 to 16	16 to 21
Output Btu/h	40-55,000	55-70,000	40-55,000	55-70,000	40-55,000	55-70,000	40-55,000	55-70,000
Flow connection	22mm	22mm	22mm	22mm	22mm	22mm	22mm	22mm
Return connection	22mm	22mm	22mm	22mm	22mm	22mm	22mm	22mm
Cold water in	n/a	n/a	15mm	15mm	n/a	n/a	15mm	15mm
Pressure relief	n/a	n/a	15mm	15mm	n/a	n/a	15mm	15mm

Condensate pipe 21.5mm OD plastic overflow pipe

NOTE 1: The boiler flow connection exits the casing on the top or bottom.
NOTE 2: The return connection is located on the right and the condensate drain on the left.

**Vortex Eco
Wall-Mounted
Programmer Options**



Optional Grant ES Kit,
Wall-mounted twin-channel
programmer



Optional Grant RS Kit Wall-mounted
programmable room thermostat

Grant Vortex Pro Kitchen/Utility Range

Introduction

The Grant Vortex Pro Kitchen/Utility range has been upgraded to enable a number of new programmer options to be used with the appliance. A plug-in programmer (EP Kit) can be installed within the fascia, or alternatively, the receiver for Grant's new wireless RFT Kit can be located within the knockout and the programmer sited conveniently within the building.

The boilers have very high SAP 2009 gross seasonal efficiencies of between 90.7 - 93.3% and feature the 'award winning' unique Grant Vortex stainless steel condensing heat exchanger, and turbulator baffle system. The 15-21 utility model has been designed to fit within a kitchen unit and, due to its reduced width, can be used as a direct replacement for most older oil-fired boilers.

There are nine models within the range covering outputs from 15-70kW (50,000-240,000 Btu/h), all of which feature Grant's new internal condensate trap.

Sealed System models

Sealed System variants of the Kitchen/Utility range are available in outputs of 15-26kW, 26-36kW and 36-46kW. Larger models above 46kW can also be converted to sealed system operation.



Dimensions (mm)

Grant Vortex Pro 15-21 kitchen/utility

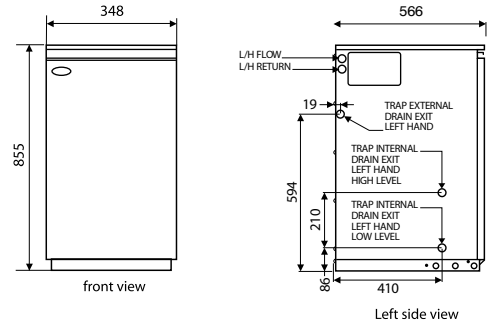

Grant Vortex Pro 15-26 kitchen/utility and system

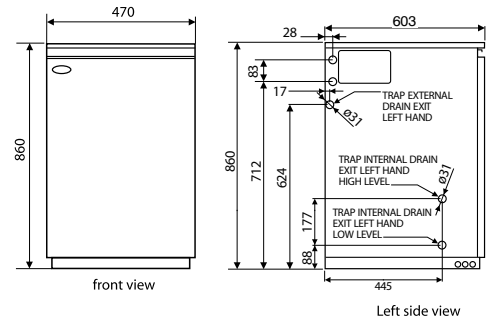

Grant Vortex Pro 26-36 and 36-46 kitchen/utility and system

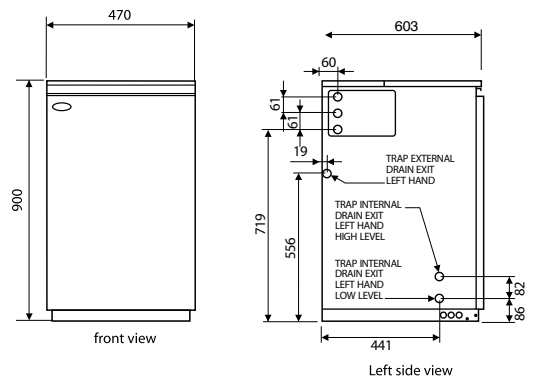

Grant Vortex Pro 46-58 and 58-70 kitchen/utility

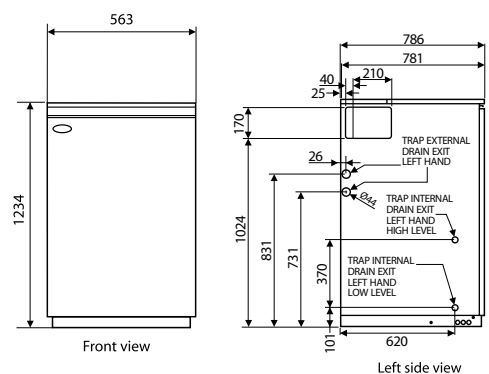

Grant Vortex Pro Kitchen/Utility Models

- VTX1521
- VTX1526
- VTX2636
- VTX3646
- VTX4658
- VTX5870

Grant Vortex Pro Kitchen/Utility Sealed System Models

- VTXS1526
- VTXS2636
- VTXS3646

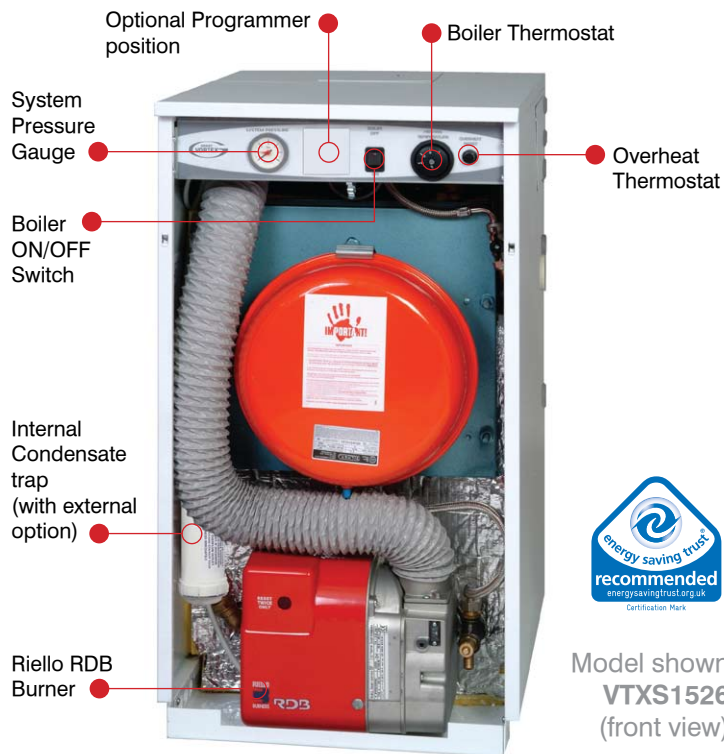

Technical specifications - Boiler Connections

Model	Kitchen/Utility Models						Kitchen/Utility System Models		
	15-21	15-26	26-36	36-46	46-58	58-70	15-26S	26-36S	36-46S
Output kW	15 to 21	15 to 26	26 to 36	36 to 46	46 to 58	58 to 70	15 to 26	26 to 36	36 to 46
Output Btu/h	50-70,000	50-90,000	90-123,000	123-157,000	157-200,000	200-240,000	50-90,000	90-123,000	123-157,000
Flow connection	22mm	22mm	28mm	28mm	1 1/4" BSP	1 1/4" BSP	22mm	28mm	28mm
Return connection	22mm	22mm	28mm	28mm	1 1/4" BSP	1 1/4" BSP	22mm	28mm	28mm
Cold water in (system kit)	n/a	n/a	n/a	n/a	n/a	n/a	15mm	15mm	15mm
Pressure relief (system kit)	n/a	n/a	n/a	n/a	n/a	n/a	15mm	15mm	15mm
Condensate pipe	21.5mm OD plastic overflow pipe								

NOTE 1: The boiler flow and return connections exit the casing on the left or right hand side.
NOTE 2: Grant Vortex Kitchen/Utility boilers are suitable for fully pumped systems only.

Vortex Pro Kitchen/Utility Programmer Options



Optional Grant EP Kit. Electronic Twin-Channel Plug-in Programmer



Optional Grant RFT Kit. Wireless Twin-Channel Programmable Thermostat

NOTE: It is also possible to control Grant Vortex Pro Kitchen/Utility models with the optional twin channel programmer (ES Kit - see page 5)

Grant Vortex Pro Outdoor Range

Introduction

The Grant Vortex Pro Range of external modules encompass Grant's original Vortex heat exchanger and have some of the highest efficiencies available in the market today. The boilers are available in four outputs ranging between 15kW and 46kW (50-157,000 Btu/h).

Bespoke features

All Pro external modules enjoy the same unique features as the Eco external modules including the factory fitted multi-directional flue, high quality external powder coated casing, built in frost protection, mains isolating switch and a test switch. However, in addition, the boilers have a higher efficiency level and are factory wired to receive an 'optional' RF (radio frequency) wireless programmer. In this situation, the receiver can be plugged into the control panel of the module, enabling the boiler to be operated using a remote controller from any room inside the house, without the need for hard wiring.



Dimensions (mm)

Grant Vortex Pro External 15-21

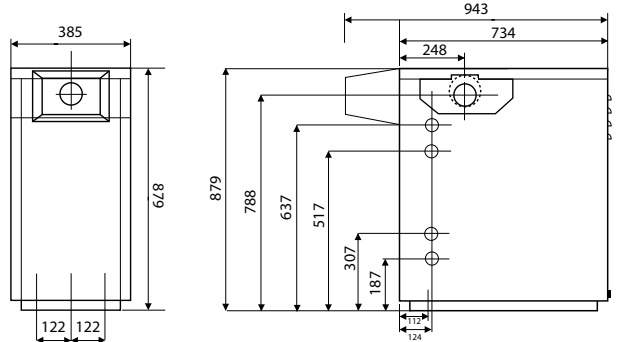

Grant Vortex Pro External 15-26 26-36 36-46

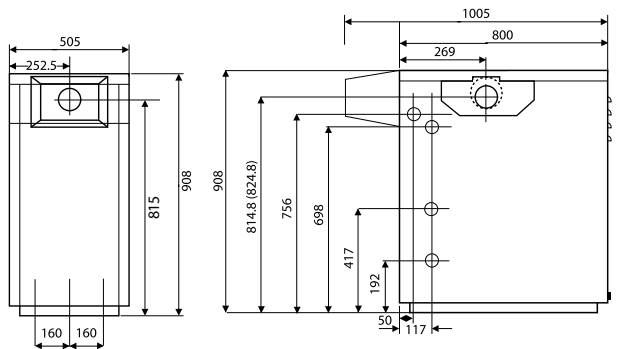

Sealed system kits

Grant Vortex Pro external condensing modules can be converted to sealed system operation by purchasing a pre-assembled kit from Grant UK. The sealed system kit includes an expansion vessel (size varies), automatic air vent, pressure relief valve and circulating pump. A filling loop and pressure gauge are also supplied as part of the kit. These can be fitted within the module casing, or ideally in a convenient site within the building, located between the cold main and central heating return.

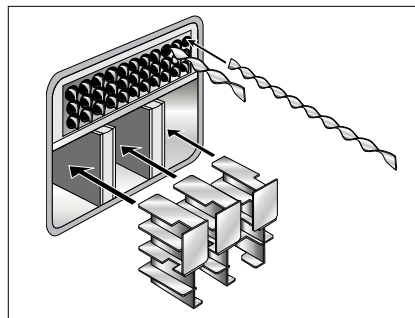

Baffle arrangement Grant Vortex 26-36 external module



Optional side flue outlet



Grant Vortex Pro External Modules

VTXOM1521

VTXOM1526

VTXOM2636

VTXOM3646

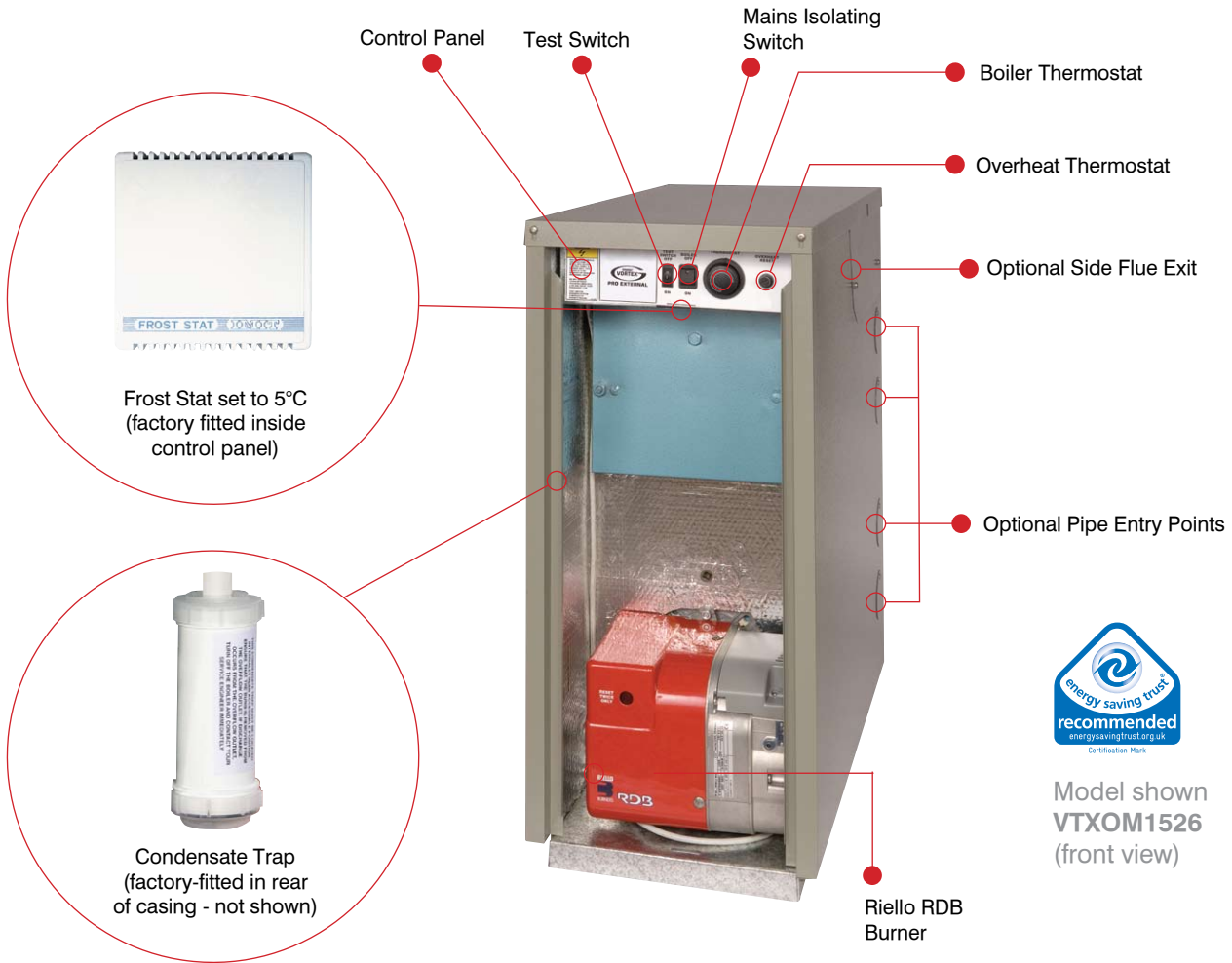

Model shown
VTXOM1526
(front view)

Technical specifications - Boiler Connections

Model	Pro External Modules			
	15-21	15-26	26-36	36-46
Output kW	15 to 21	15 to 26	26 to 36	36 to 46
Output Btu/h	50-70,000	50-90,000	90-123,000	123-157,000
Flow connection	22mm	22mm	28mm	28mm
Return connection	22mm	22mm	28mm	28mm
Cold water in (system kit)	15mm	15mm	15mm	15mm
Pressure relief (system kit)	15mm	15mm	15mm	15mm
Condensate pipe	21.5mm OD plastic overflow pipe			

NOTE 1: All boiler connections can be positioned to the left or right of the appliance.
NOTE 2: Grant Vortex Condensing Modules are suitable for fully pumped systems only.

Vortex Pro External Programmer Options



Optional Grant RFT Kit, Wireless Twin-Channel Programmable Thermostat

NOTE: It is also possible to control Grant Vortex Pro External modules with the optional twin channel programmer (ES Kit - see page 5)

Grant Vortex Pro Combi Range

Introduction

For almost two years Grant has been working behind the scenes on brand new electronic versions of the successful Grant Vortex Combi Range with the aim of incorporating as many of the additional features and benefits customers have requested, whilst bringing the technology installed in these appliances up to the minute. The models now include internal frost protection, neon diagnostic indicators and a factory fitted internal condensate trap (this can be sited externally if preferred), which is designed to make installation and servicing easier. The Grant Vortex Pro Electronic Condensing Combi's are available as internal or external models in three sizes, 21kW, 26kW* and 36kW.

Unique designs

Grant Vortex Pro Combi's feature much larger heat exchangers which, due to their low water content and larger surface area, vastly increase the hot water performance available and mixing valves are pre-set at 50°C, controlling accurately the hot water draw off temperature from the boiler. They also feature a low system pressure cut off switch, enabling the combi to protect itself in the unlikely event of system water loss. Additionally, there are two very accurate electronic temperature controls which allow the boiler to operate in condensing mode on central heating, whilst maintaining its instant hot water production.

*Grant Vortex Pro 26kW Internal Combi - Awarded 'Which? Best Buy 2008'.



Dimensions (mm)

Grant Vortex Pro Internal Combi 21e and 26e

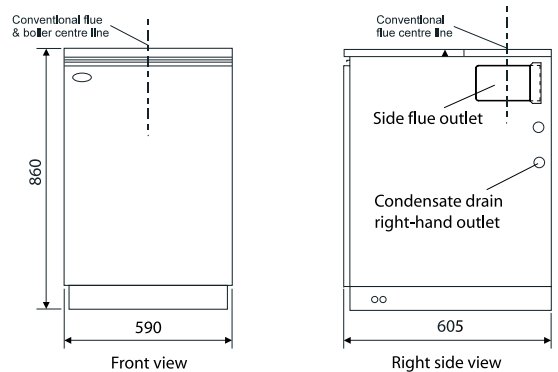

Grant Vortex Pro Internal Combi 36e

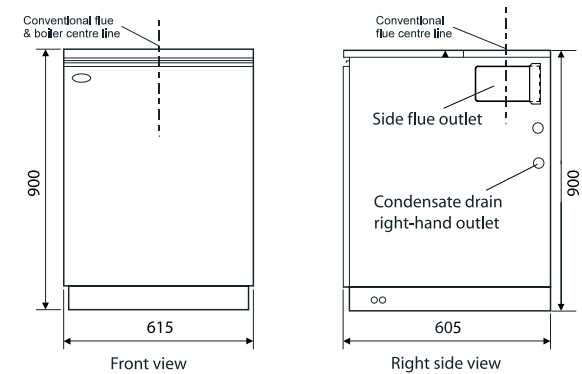

Grant Vortex Pro External Combi 21e, 26e and 36e

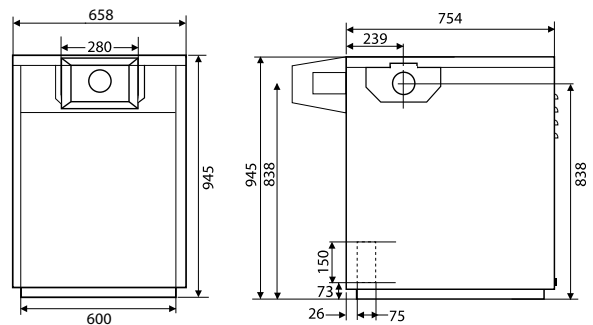

Typical hot water performance

VTXCOMBI21* 15 litres per minute at an average temperature of 50°C. Recovery time 4 minutes approx. Based upon 100 litre draw off.

VTXCOMBI26* 17 litres per minute at an average temperature of 50°C. Recovery time 4 minutes approx. Based upon 100 litre draw off.

VTXCOMBI36* 20 litres per minute at an average temperature of 50°C. Recovery time 3 minutes approx. Based upon 100 litre draw off.

MAINS WATER PRESSURE

Minimum 2.5bar (36psi) Maximum 8bar (115psi)

*Hot water flow rate is dependent on mains pressure available. Figures based upon an incoming mains water temperature of 10°C.



Grant Vortex Pro Internal Combi Models

- VTXCOMBI21
- VTXCOMBI26
- VTXCOMBI36

Grant Vortex Pro External Combi Modules

- VTXOMCOMBI21
- VTXOMCOMBI26
- VTXOMCOMBI36

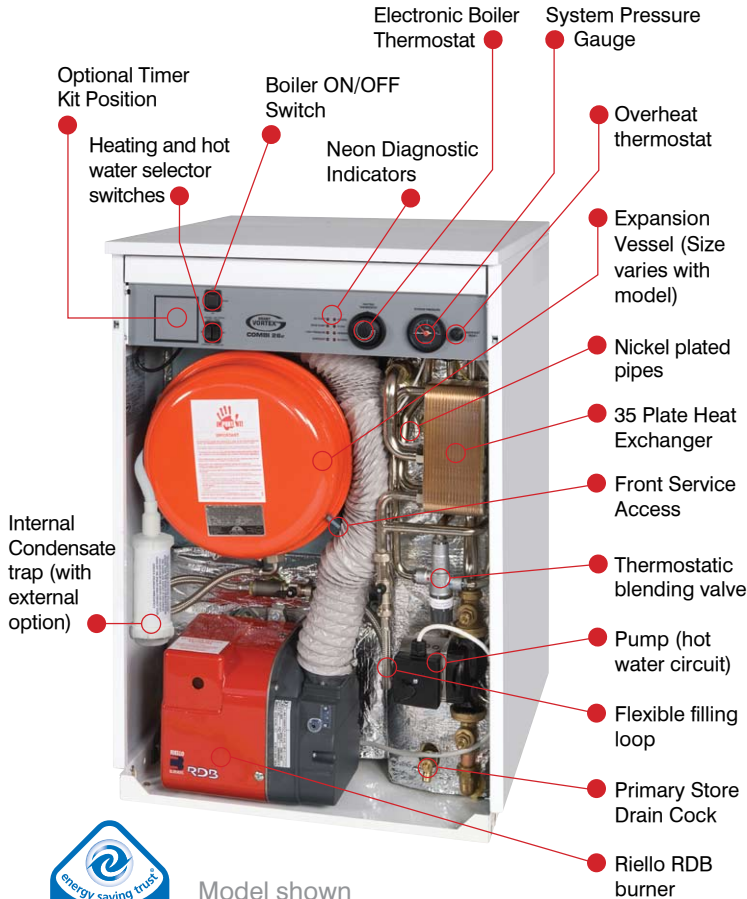

Model shown
VTXCOMBI26 (front view)

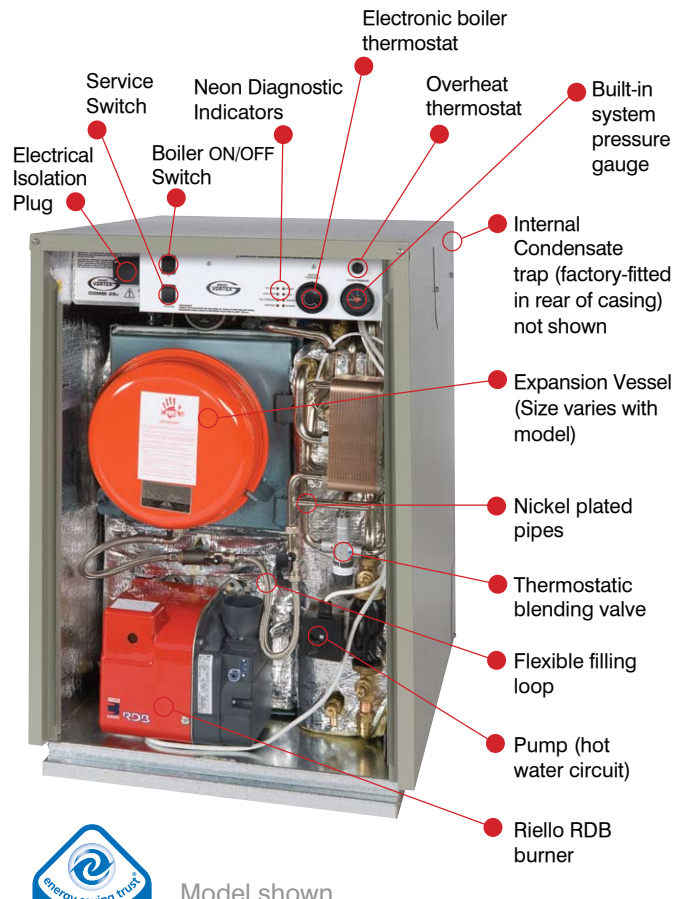

Model shown
VTXOMCOMBI26 (front view)

Technical specifications - Boiler Connections

Model	Pro Internal Combi Models			Pro External Combi Models		
	21	26	36	21	26	36
Output kW	21	26	36	21	26	36
Output Btu/h	70,000	90,000	123,000	70,000	90,000	123,000
Flow connection	22mm	22mm	28mm	22mm	22mm	28mm
Return connection	22mm	22mm	28mm	22mm	22mm	28mm
Cold water in	15mm	15mm	22mm	15mm	15mm	22mm
Hot water out	15mm	15mm	22mm	15mm	15mm	22mm
Pressure relief	15mm	15mm	15mm	15mm	15mm	15mm
Condensate pipe	21.5mm OD plastic overflow pipe					

NOTE 1: All boiler connections can be positioned to the left or right of the appliance.
NOTE 2: Grant Vortex Pro Internal and External Condensing Combis are suitable for fully pumped systems only.

**Vortex Pro Combi
Timer Options**



Optional Grant MT Kit
Single-Channel Mechanical Timer



Optional Grant RFT Kit. Wireless Twin-Channel
Programmable Thermostat

NOTE: It is also possible to control Grant Vortex Pro Combi's with the optional twin channel programmer (ES Kit - see page 5)

Energy Management Controls

Save up to 15% on annual fuel bills

Improving efficiencies

Fuel prices are increasing year on year and this is having a major effect on domestic heating costs. Although the price of fuel cannot be changed, steps can be taken to reduce the amount used. Recent amendments to the Building Regulations have increased the use of far more efficient Condensing appliances in both gas and oil, but unless the control of these boilers is also considered at the time of installation, the full benefit of their high efficiency may not be gained.

How most heating systems work

When air temperatures in the house fall below the setting on the room thermostat, a signal is sent for the boiler to fire and warm the house. Unfortunately a disadvantage of this simple arrangement is that the thermostat only tells the boiler to turn on or off when the house is too cold or too hot, respectively. Some systems are even installed without a room thermostat (boiler interlock), relying solely on individual thermostatic radiator valves.

In either case no consideration is given to maintaining the correct flow and return temperatures that enable a boiler to operate in condensing mode; or to any external temperature fluctuations. Looking at it another way, how many miles per gallon would a car get if the only method of controlling speed was to accelerate until it is going too fast and then apply the brakes? That is exactly how most heating systems work.

How heating systems should work

Boiler flow and return temperatures should be monitored and controlled, and the system must be able to react promptly to internal and external air temperature changes.

Using the car analogy, an accelerator pedal is adjusted carefully to maintain a comfortable driving speed and good fuel economy. Why not the same with a domestic heating system? By installing a Grant Energy Management Control, the water temperature in the heating system is constantly measured to maintain comfort and improve efficiency.



Grant Efficiency Optimiser

GEO360 technology

The Grant Efficiency Optimiser (GEO360) is a smart weather compensating control unit comprising of a controller, two pipe thermostats together with an internal and external air sensor, coupled to a 4-Port mixing valve. With the information retrieved through the outdoor air sensor (fitted on a north facing wall) the unit can adjust system water temperature to match a heat output closer to the needs of the home. In fact, the system will adapt before it even feels too cold or too hot. In periods of warm weather the GEO360 will automatically shut the system down until it is needed again. Flow and return temperatures can be pre-set on the control module enabling condensing boilers to operate in condensing mode more often, thereby saving fuel and making the system more environmentally friendly.



Thermostat only

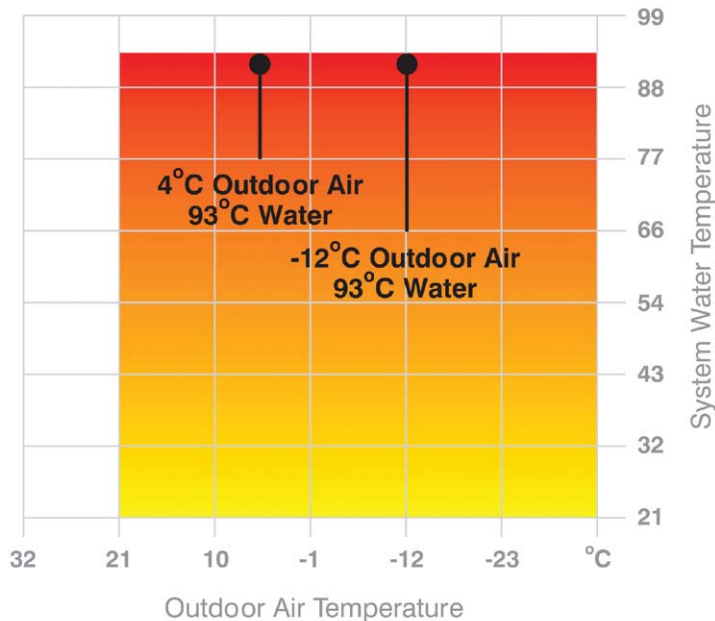

With a GEO360

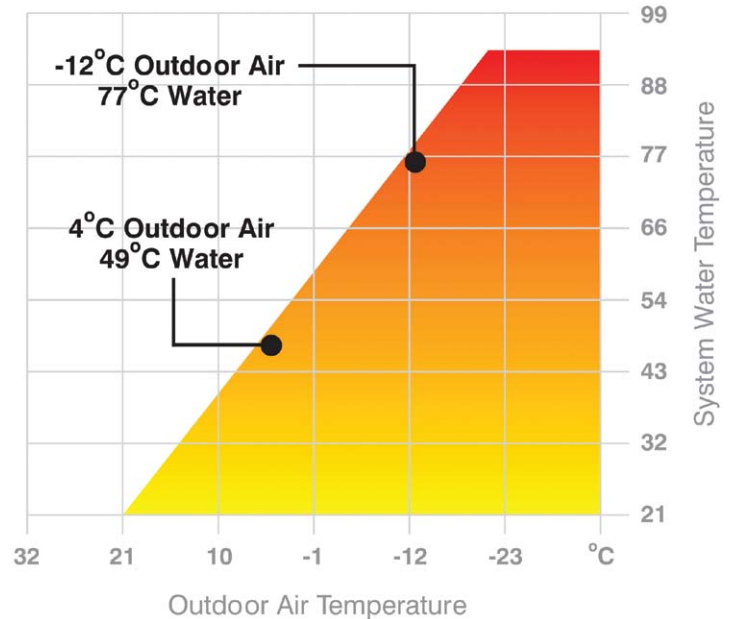

The GEO360 range

There are two Grant Efficiency Optimiser models available. The GEO360/28 has 28mm compression fittings and is suitable for systems up to 36kW (123,000 Btu/h). If required, a reducing set (28mm reducing to 22mm) should be used for systems under 21kW (70,000 Btu/h). The GEO360/35 has 35mm compression fittings and is suitable for systems from 36kW to 70kW (123,000 - 240,000 Btu/h).



GEO360 Performance

Intelligent weather compensation

The GEO360 monitors weather conditions throughout the year regardless of the season. Without the control unit, a heating system does not know if it is a cool autumn night or the coldest winter day. Therefore it works as if it was always the coldest day of the year and heats the water to a maximum temperature.

The following diagrams show how the GEO360 adapts a heating system to the changing seasons, thus saving energy.

Autumn

Winter

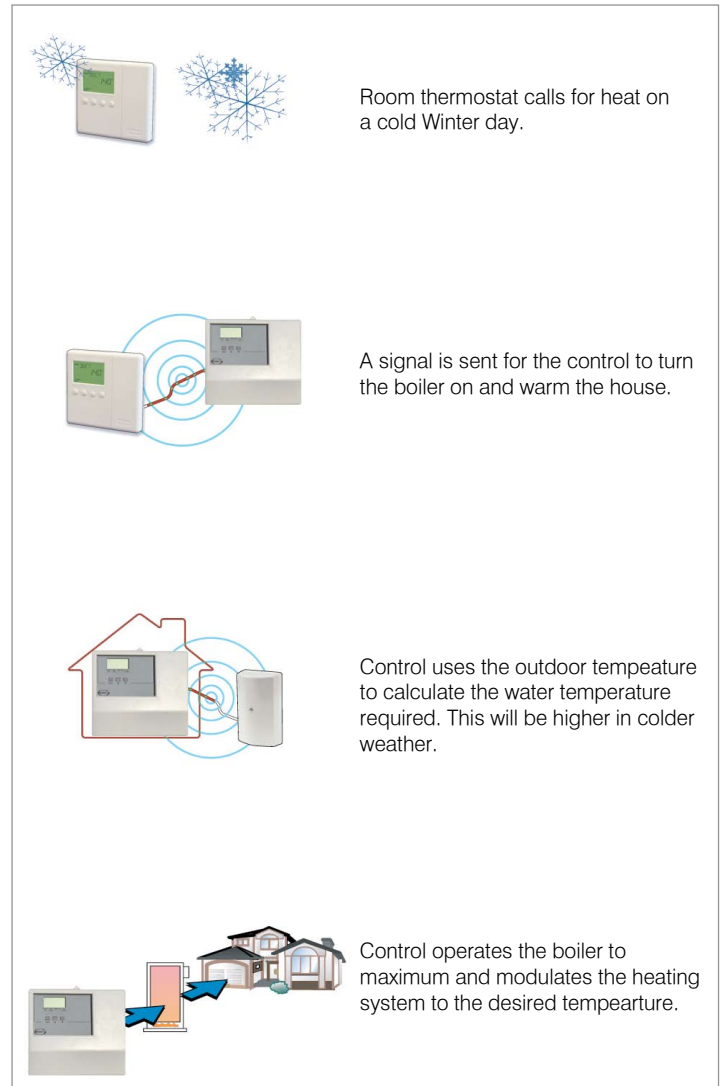
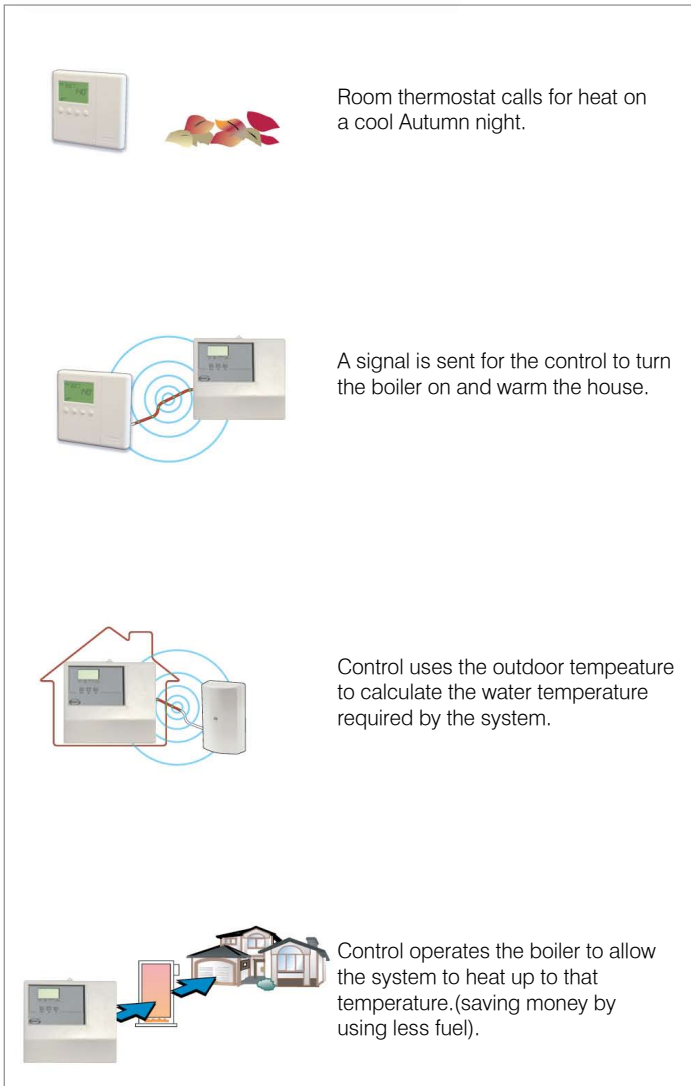

GEO360 Savings

How much fuel will I save?

Weather compensating controls are not a new concept. Most are generally found in commercial applications, such as office buildings, factories, etc.

The GEO360 has been developed to make this technology affordable for the domestic market. Savings depend on many factors, however when fitted on a standard system, a fuel reduction in the region of 10-15% per annum should be achievable, and in many cases this will be higher, so payback would typically be within three years!

Compatibility

The GEO360 is a stand-alone unit that is compatible with most types of gas and oil-fired boilers and can be coupled with any standard system programmers.

Typical heating fuel costs

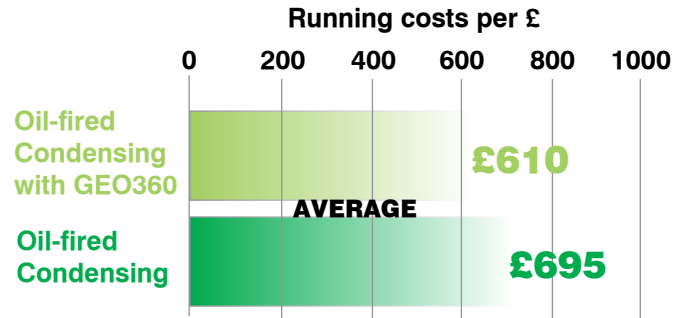

*Figures reproduced with permission from Sutherland Tables, showing a 5-year average running cost for a 3-bed house in the UK up until May 08.

Example of Pipework layout Schematic

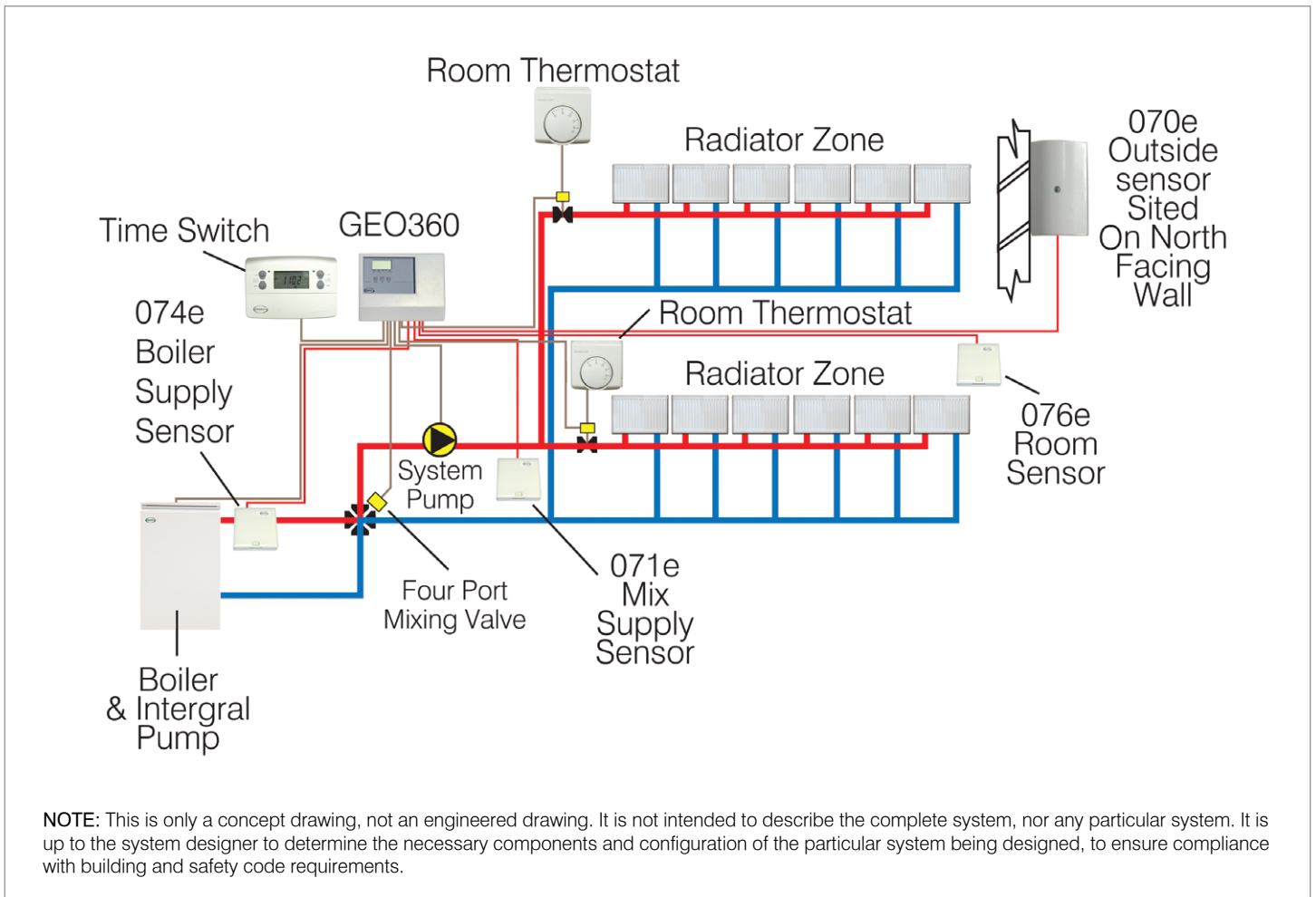

General Information

Easy to commission, service and maintain

As with all oil-fired appliances, Grant Vortex Condensing Boilers require commissioning at the time of installation. This simple process ensures that the boiler is working at peak efficiency which, in turn, will result in lower running costs and long term reliability.

Annual maintenance is also made easy by Grant's cleverly designed front service access to both the burner and all the internal serviceable parts. This feature enables Grant Vortex Condensing Boilers to be fitted neatly and unobtrusively within either the kitchen or utility room environment. Alternatively, if internal siting is a problem, space-saving outdoor versions are available.

Standard Assessment Procedure (SAP)

SEDBUK was developed by the Government alongside boiler manufacturers, under their 'Energy Efficiency Best Practice Programme'. It was designed as a fair basis for comparisons of boiler energy performance when installed in a typical domestic situation in the UK.

To determine boiler efficiencies, a 'Standard Assessment Procedure' more commonly known as SAP, is used. SAP is the Government's standard method for energy rating. SAP ratings enable the comparison of energy efficiencies and demonstrate the likely effect of improvements to a property in terms of energy use.

Since SEDBUK was introduced in 1999, it has undergone many changes, the most recent being the move from SAP 2005 to SAP 2009. The changes focus on improving the accuracy of the way the efficiencies are worked out. SAP 2009 incorporates a key revision in the assumed carbon emissions per kWh of oil used by the boiler. It may appear that the efficiencies of boilers have reduced with SAP 2009, but it is important to understand that the new methodology gives a more realistic estimate of the average annual boiler efficiency when installed in typical conditions, based on evidence from recent independent testing and field trials.

Visit: www.sedbuk.com for more information.

Plumbing

Condensing boilers operate at extremely high efficiency levels, producing cool flue gas temperatures, resulting in a 'plume' of vapour being visible at the flue terminal. This plume (steam) is a normal condition of condensing boiler operation and indicates that the appliance is working efficiently. As an alternative to a low level balanced flue kit, high level, or vertical kits are available, which moves the plume to a higher level.

Fuel

All burners are supplied factory set at the stated output for use on standard grade Kerosene – Class C2. Grant Vortex Condensing Boilers are not suitable for use with Class D gas oil.

Installation

Installation must comply with the current British Standards and The Building Regulations. Comprehensive technical information can be found in the installation manual, supplied with every boiler.

Guarantees

The unique heat exchanger on Grant Vortex Condensing Boilers is covered by a 5-year guarantee. All other component parts of the boiler are guaranteed for 2 years from the date of purchase (excluding consumable items), subject to being installed in accordance with the manufacturers instructions. There are also optional annual, or 3-year extended warranty schemes available. On completion of the installation all Grant Vortex Condensing Boilers must be commissioned and the guarantee registration form returned to Grant UK.

After sales service

For peace of mind, all Grant central heating boilers are backed by a national network of independent service engineers. In the unlikely event of a problem occurring, your installer should telephone our Customer Service Department on: **01380 736920**



GRANT ENGINEERING (UK) LTD
HOPTON HOUSE, HOPTON INDUSTRIAL ESTATE,
DEVIZES, WILTSHIRE, SN10 2EU
T: 01380 736920 F: 01380 736991
E: SALES@GRANTUK.COM W: WWW.GRANTUK.COM

This leaflet is accurate at the time of printing but as Grant UK has a policy of continual improvement it may be superseded. We reserve the right to amend specifications without prior notice. The statutory rights of the consumer are not affected.

All products manufactured under I.S. EN ISO 9001 and ISO 14001.

™ THE GRANT 'EZ-FIT FLUE' SYSTEM is a Trade Mark of Grant Engineering Limited.

© Grant Aerona, Grant Spira, Grant Vecta, Grant Vortex, Grant Solar, Grant Aurora, Grant Sahara, Grant CombiSOL, Grant WinterSOL, Grant MonoWave, Grant DuoWave, Grant ThermoWave, Euroflame and Multi Pass are registered trade marks of Grant Engineering Limited. The contents of this leaflet are fully protected by copyright and nothing may be reproduced without permission from Grant UK.

