



Glow-worm

Instructions for Use Installation and Servicing

To be left with the user

Energysaver Combi

80 100

G.C. No. 47-047-01 G.C. No. 47-047-02

Condensing Combination Boiler



This is a Cat I_{2H} Appliance

Reference in these instructions to British Standards and Statutory Regulations/Requirements apply only to the United Kingdom.
For Ireland the rules in force must be used.

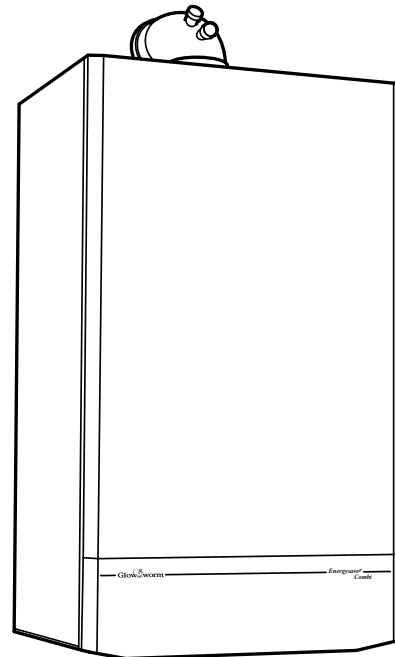

6548

The instructions consist of three parts, User, Installation and Servicing Instructions, which includes the Guarantee Registration Card. The instructions are an integral part of the appliance and must, to comply with the current issue of the Gas Safety (Installation and Use) Regulations, be handed to the user on completion of the installation.

Guarantee Registration

Thank you for installing a new Glow-worm appliance in your home.

Glow-worm appliances' are manufactured to the very highest standard so we are pleased to offer our customers' a Comprehensive First Year Guarantee.

In the centre pages are to be found your Guarantee Registration Card, which we recommend you complete and return as soon as possible.

If this card is missing you can obtain a copy or record your registration by telephoning the Heatcall Customer Service number 01773 828100.

Our Guarantee gives you peace of mind plus valuable protection against breakdown by covering the cost of:

- All replacement parts**
- All labour charges**
- All call-out charges**

REGISTER YOUR GLOW-WORM APPLIANCE
FOR 1ST YEAR GUARANTEE PROTECTION

CALL 0208 247 9857

HEATCALL Customer Services:
Tel: (01773) 828100
One Contact Local Service Fax: (01773) 828070

Hepworth Heating Ltd.,
Nottingham Road, Belper, Derbyshire. DE56 1JT
General/Sales enquiries:
Tel: (01773) 824141 Fax: (01773) 820569

Contents

CONTENTS	DESCRIPTION	SECTION	PAGE No.
INSTRUCTIONS FOR USE	Introduction		3
	Operating the Boiler		3
	Clock Setting		5
INSTALLATION INSTRUCTIONS	General Information	1	6
	Boiler Position	2	8
	Flue Location and Ventilation	3	9
	Heating System	4	11
	Domestic Hot Water System	5	13
	Installation Preparation	6	13
	Flue Preparation	7	15
	Boiler Fixing	8	17
	Gas, Water and Condensate Conns.	9	17
	Electrical Connections	10	18
	Commissioning	11	20
SERVICING INSTRUCTIONS	Servicing	12	25
	Fault Finding	13	29
	Replacement Parts	14	32

Important Information

General

Please read these instructions and follow them carefully for the safe and economical use of your boiler.

Once the controls are set, the boiler is automatic in operation.

The Energysaver 80 and 100 Combi boilers are able to provide room heating as part of a central heating system and domestic hot water direct from the cold water supply, without the need for secondary storage.

Gas Category

This boiler is for use only on G20 gas.

Gas Safety (Installation and Use) Regulations

In your own interests and that of safety, it is the Law that ALL gas appliances are installed by a competent person in accordance with the current issue of the above regulations.

Gas Testing and Certification

The boiler is tested and certificated for safety and performance. It is, therefore, important that no alteration is made to the boiler unless approved, in writing, by Hepworth Heating Ltd.

Any alteration not approved by Hepworth Heating Ltd., could invalidate the certification, boiler warranty and may also infringe the current issue of the Statutory requirements.

CE Mark

This boiler meets the requirements of Statutory Instrument, No. 3083 The Boiler Efficiency Regulations, and therefore is deemed to meet the requirements of Directive 92/42/EEC on the efficiency requirements for new hot water boilers fired with liquid or gaseous fuels.

Type test for purposes of Regulation 5 certified by:

Notified body 0063.

Product/production certified:

Notified body 0063.

The CE Mark on this appliance shows compliance with:

1. Directive 90/396/EEC on the approximation of the Laws of the Member States relating to appliances burning gaseous fuels.
2. Directive 73/23/EEC on the harmonization of the Laws of the Member States relating to electrical equipment designed for use within certain voltage limits.
3. Directive 89/336/EEC on the approximation of the Laws of the Members States relating to electromagnetic compatibility.

Control of Substances Hazardous to Health

Under Section 6 of The Health and Safety at Work Act 1974, we are required to provide information on substances hazardous to health.

The adhesives and sealants used in this appliance are cured and give no known hazard in this state.

Refractory Ceramic Fibre

This product uses insulation material containing Refractory Ceramic Fibre (RCF), which are man-made vitreous silicate fibres. Excessive exposure to these materials may cause temporary irritation to eyes, skin and respiratory tract, consequently, it makes sense to take care when handling these articles to ensure that the release of dust is kept to a minimum.

To ensure that the release of fibres from these RCF articles is kept to a minimum, during installation and servicing we recommend that you use a HEPA filtered vacuum to remove any dust accumulated in and around the boiler before and after working on the boiler. When replacing these articles we recommend that the replaced items are not broken up, but are sealed within heavy duty polythene bags, clearly labelled as RCF waste. This is not classified as "hazardous waste" and may be disposed of at a tipping site licensed for the disposal of industrial waste.

Important Information

Protective clothing is not required when handling these articles, but we recommend you follow the normal hygiene rules of not smoking, eating or drinking in the work area and always wash your hands before eating or drinking.

Normal handling should not cause discomfort, but follow normal good hygiene and wash your hands before eating, drinking or going to the lavatory.

If you do suffer irritation to the eyes or severe irritation to the skin seek medical attention.

Insulation Pads/Ceramic Fibre, Glass yarn

These can cause irritation to skin, eyes and the respiratory tract.

If you have a history of skin complaint you may be susceptible to irritation. High dust levels are usual only if the material is broken.

Reset Button

Refer to diagram 1 which shows the fascia behind the drop down panel.

If the burner goes out check the digital display. Flashing digits on the display indicate a fault. Allow the boiler to cool down for at least four minutes then press the 'Reset' button. This should restart the boiler.

To obtain service call your installer or Heatcall (Glow-worm's own service organisation) using the telephone number given on the front page of these instructions.

Gas Leak or Fault

If a gas leak or fault exists or is suspected, turn the boiler mains electrical supply off and turn off the gas supply at the meter. Consult your local gas company or your local installation/servicing company.

Electrical Supply Failure

The boiler will not work without an electrical supply.

Normal operation of the boiler should resume when the electrical supply is restored. If not, the boiler safety cut-off may have operated, please refer to the following section to reset.

Reset any external controls, to resume normal operation of the central heating.

The digital timer, if fitted, has a lithium battery back up and will not need resetting.

Introduction

Operating the Boiler

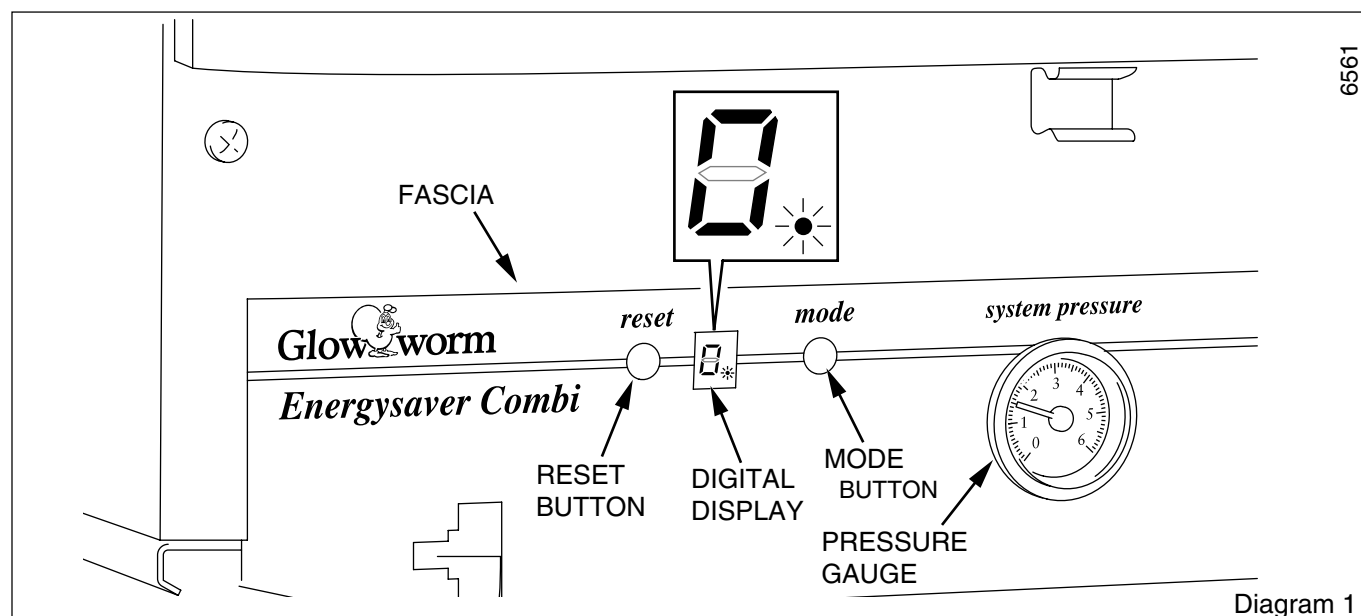

To Operate the Boiler

1. Check that all five isolating valves are open with their slots in line with the length of the valve, see diagram 8.1 in Installation instructions.
2. CAUTION: A sealed pressurised system must be filled and pressurised by a competent person.

Only operate the boiler when you are sure that the system has been filled and pressurised. Check this by looking at the

pressure gauge which should read a minimum of 1.0bar, see diagram 1.

3. Open a hot water tap, check that water flows, then close it.
4. If you are in any doubt about the boiler being filled with water contact your installation/servicing company or the local gas company.
5. Check that the electrical supply to the boiler is ON at the external isolator.

Operating the Boiler

6. Set clock/timer (if fitted) and any remote controls as required.
7. If the display is flashing, press the 'reset' button, shown on diagram 1.
8. The boiler should now operate. It is factory preset to supply domestic hot water up to 65°C and central heating up to 70°C.

User Controls

The operation of the boiler can be altered by using the 'Mode' button. Temperature Selection and Control Options are detailed in sections 11.8 to 11.11.

Additional Options

Other modes are available by repeatedly pressing the 'Mode' button. These cover fault indication and servicing and should only be accessed by the service engineer. Repeated pressing of the 'Mode' button will eventually return the display to show boiler temperature, see diagram 11.4.

To Turn the Boiler Off

It is preferable to leave the electrical supply on whenever possible to permit operation of the built-in frost protection (see 'Protection Against Freezing') and daily pump and valve exercise.

To turn off the central heating use the room thermostat or clock/timer.

To turn off the domestic hot water select  (see section 11.8 and diagram 11.4).

For holiday mode, refer to section 11.8.

To turn off the boiler for servicing, isolate it from the electrical supply. To turn it on again follow the instructions given in 'To Operate the Boiler'.

Maintenance and Servicing

If this appliance is installed in a rented property there is a duty of care imposed on the owner of the property by the current issue of the Gas Safety (Installation and Use) Regulations, Section 35.

Servicing/maintenance should be carried out by a competent person in accordance with the rules in force in the countries of destination.

To obtain service, please call your installer or Heatcall (Glow-worm's own service organisation) using the telephone number on the back cover of this booklet.

Please be advised that the 'Benchmark' logbook should be completed by the installation engineer on completion of commissioning and servicing.

All CORGI Registered Installers carry a CORGI ID card, and have a registration number. Both should be recorded in your boiler Logbook. You can check your installer is CORGI registered by calling CORGI direct on :- 01256 372300.

Clearances

If the boiler is fitted into a compartment or cupboard do not use the compartment or cupboard for storage.

Protection Against Freezing

The boiler has a built in frost protection programme as long as the electricity and gas are left switched on.

This device only protects the boiler. Any other exposed areas of the system should be protected.

If the mains electricity and gas are to be turned off for any long periods during severe weather, it is recommended that the whole system, including the combination boiler, should be drained to avoid the risk of freezing.

If in doubt, contact your installation/servicing company for advice.

As a safety feature the boiler will stop working if the condensate drain becomes blocked. The display will repeatedly flash 'U' then 'E'. During freezing conditions this may be due to the forming of ice in the condensate drain external to the house. Release an ice blockage by the use of warm cloths on the pipe. Press the reset button to restart the boiler. Contact your installation / servicing company if the fault persists.

Draining and Filling

CAUTION: This boiler works in a pressurised system which must only be drained, refilled and pressurised by a competent person.

NOTE: If the pressure gauge indicates a loss of system pressure, i.e. less than 0.7bar, the appliance will shut down showing flashing: '7' then 'E' on the display. **YOU MUST CONTACT YOUR INSTALLER.**

Pressure Relief Safety Valve

CAUTION: A pressure relief safety valve and discharge pipe is fitted to the boiler. This valve must not be touched. Should there be any discharge from the pipe, isolate the boiler electrical supply and contact your installation/servicing company.

Cleaning

WARNING: This appliance contains metal parts and care should be taken when handling and cleaning with particular regard to edges.

The boiler casing can be cleaned using a mild liquid detergent with a damp cloth, then a dry cloth to polish.

Do not use any form of abrasive or solvent cleaner as you may damage the paint work.

Boiler Casing

CAUTION. Do not remove or adjust the casing in any way, as incorrect fitting may result in incorrect operation or failure to operate at all. If in doubt seek advice from the local gas company or your installation/servicing company.

Replacement Parts

If replacement parts are required apply to your local supplier or British Gas.

Please quote the name of the appliance.

Condensation Plumbing

Like all condensing boilers this appliance will produce a plume of condensation from the flue terminal in cool weather. This is due to the high efficiency and hence low flue gas temperature of the boiler.

Clock Setting

Setting Instructions for Electro/mechanical Clock - if fitted

Refer to diagram 2.

This clock has a twenty four hour dial, i.e. 1pm is '13'.

To set the time, turn the whole face clockwise until the pointer is against the time of day.

To set any "Off" time, push the tappets outwards.

To set any "On" time, push the tappets inwards.

Time can be set either "On" or "Off" in fifteen minute segments.

Note. The clock supplied is fitted with an override device, which switches the clock programme "On" or "Off" permanently. The switch will need to be repositioned to resume programmed working.

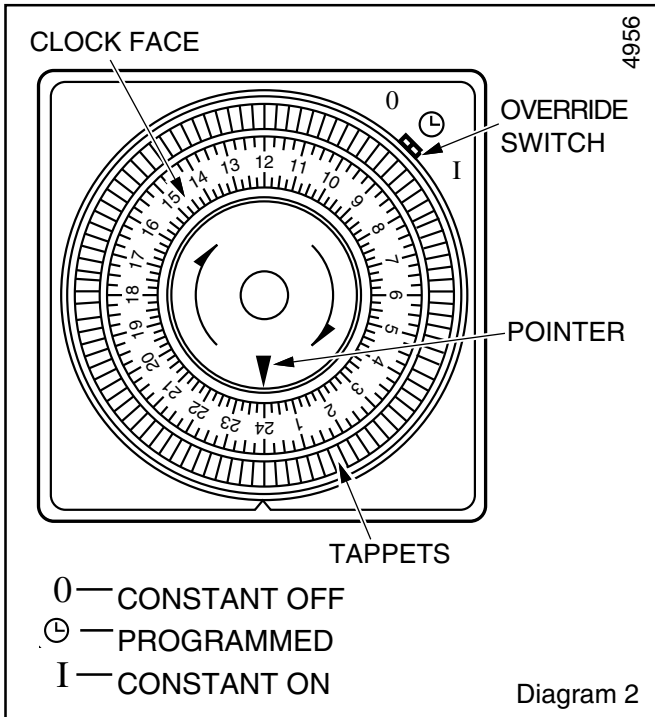

Diagram 2

Setting Instructions for the 7 Day Digital Clock/Timer - if fitted

Refer to diagram 3.

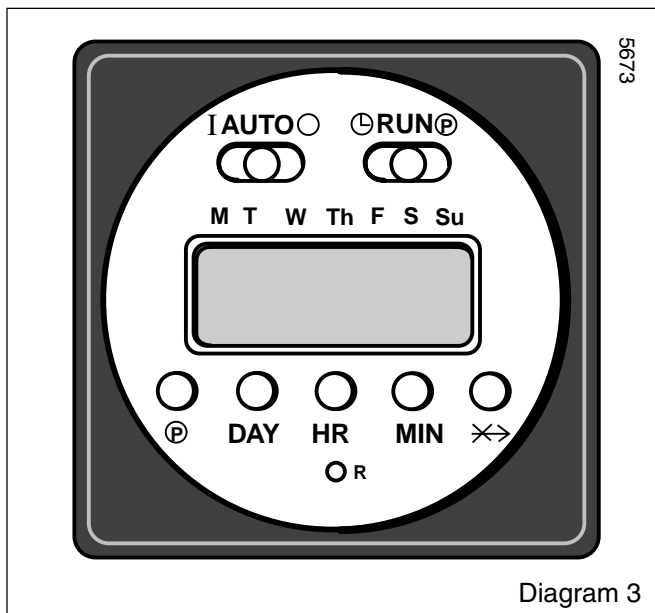



Diagram 3

This is a 24 hour clock/timer, that is 1pm is '13:00', and has 8 "ON" and 8 "OFF" daily switching actions.

It is fitted with a lithium battery back up which protects the programme in the event of an electrical failure. The battery should have a life of several years.

Setting the Clock

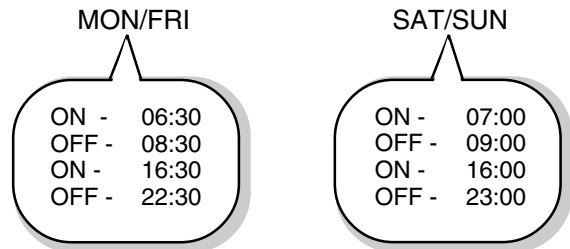

1. With both AUTO and RUN switches set to the central position, press R reset button, the display will flash.
2. Set RUN switch to .
3. Set day of week by pressing button DAY.
4. Set time of day by pressing buttons HR and MIN.
5. Set RUN switch to the central position, colon will flash, this indicates the clock is set.

With the clock set, the factory preset programme shown below will operate.



Setting Timed Programmes

With the clock set to the correct time, see SETTING THE CLOCK paragraphs 1-4, and then continue as follows:

1. Set RUN switch to , the display will indicate the 1st (ON) preset programme and the symbol .
2. Set day of week to be programmed by pressing the DAY button.

Note. The days can be selected individually or as groups:

Mon-Fri., Mon-Sat., Mon-Sun., Sat/Sun.

An arrow will be displayed under the day or days selected.

3. Set time of day by pressing the buttons HR and MIN.
4. Press button  to confirm programmes, the display will indicate the 2nd (OFF) preset programme and subsequently, 3rd, 4th, 5th, 6th, 7th, 8th to 16th.

5. Repeat procedures 2, 3 and 4 until desired programmes are set.

Note. It is not a requirement to use all of the 8 on and 8 off programmes.

6. Set the RUN switch the central position, your appliance will now operate at the programmed times.

General Notes.

With the AUTO switch in the I position the central heating will operated constantly ON.

With the AUTO switch in the O position the central heating will not operate.

Soft Override button indicated by the symbol , this function will override the current central heating programme for the next available.

ON time programmes are indicated by the symbol .

1 General Information

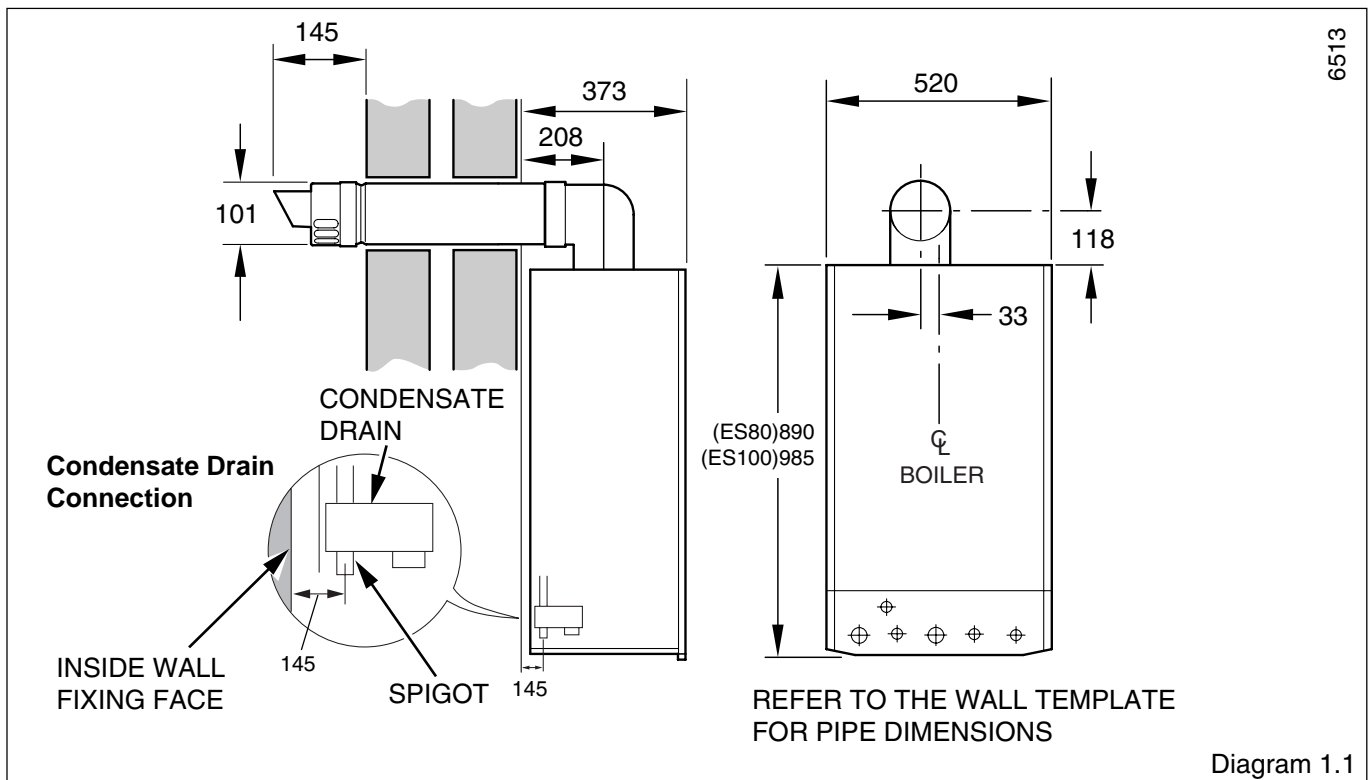

Diagram 1.1

1.1 Installation

Where no British Standards exists, materials and equipment should be fit for their purpose and of suitable quality and workmanship.

WARNING: When installing the appliance, care should be taken to avoid any possibility of personal injury when handling sheet metal parts.

The installation of this boiler must be carried out by a competent person in accordance the rules in force in the countries of destination.

Manufacturer's instructions must not be taken as overriding statutory requirements.

1.2 Gas Supply

This boiler is for use only on G20 gas.

The gas installation must be in accordance with the current issue of BS6891.

The supply from the governed meter must be of adequate size to provide a steady inlet working pressure of 20mbar (8in wg) at the boiler.

On completion, test the gas installation for soundness using the pressure drop method and suitable leak detection fluid, purge in accordance with the above standard.

1.3 Data Label

The data label is on the base panel inside the appliance.

1.4 Electrical Supply

WARNING: The boiler must be earthed.

All system components shall be of an approved type and all wiring to current I.E.E. wiring regulations.

The boiler must be connected to a permanent 230V ac, 50Hz supply.

Connection of the whole electrical system of the boiler, including any heating controls, to the electrical supply must be through one common isolator.

Isolation should be by a double pole switched fused spur box, with a minimum gap of 3mm for both poles. The fused spur box should be readily accessible and preferably adjacent to the appliance. It should be identified as to its use.

Alternatively connection can be made through an unswitched shuttered socket and 3A fused 3 pin plug.

The mains supply cable and other cables connected to the boiler must be the PVC flexible type of at least 0.75mm² (24/0.20mm).

The colours of three core flexible cable are, blue - neutral, brown - live, green and yellow - earth.

The wire coloured blue must be connected to the terminal marked "N" or "Black".

The wire coloured brown must be connected to the terminal marked "L" or "Red".

The wire coloured green and yellow must be connected to the terminal marked "E" or "Green" or the earth symbol \perp .

1.5 Condensate

Being a condensing boiler, a condensate drain MUST be fitted.

Condensate should, if possible, be discharged into the internal household draining system, i.e. sink or washing machine drain.

If this is not practical, discharge can be made externally into the household drainage system or a purpose designed soak away.

It is recommended that any external condensate drain pipe is insulated and preferably of larger diameter to prevent it freezing up in adverse weather conditions.

The condensate drain pipe should be checked during servicing and any debris removed.

Refer to the British Gas Publication "Guidance Note For The Installation of Domestic Condensing Boilers" for further information.

1 General Information

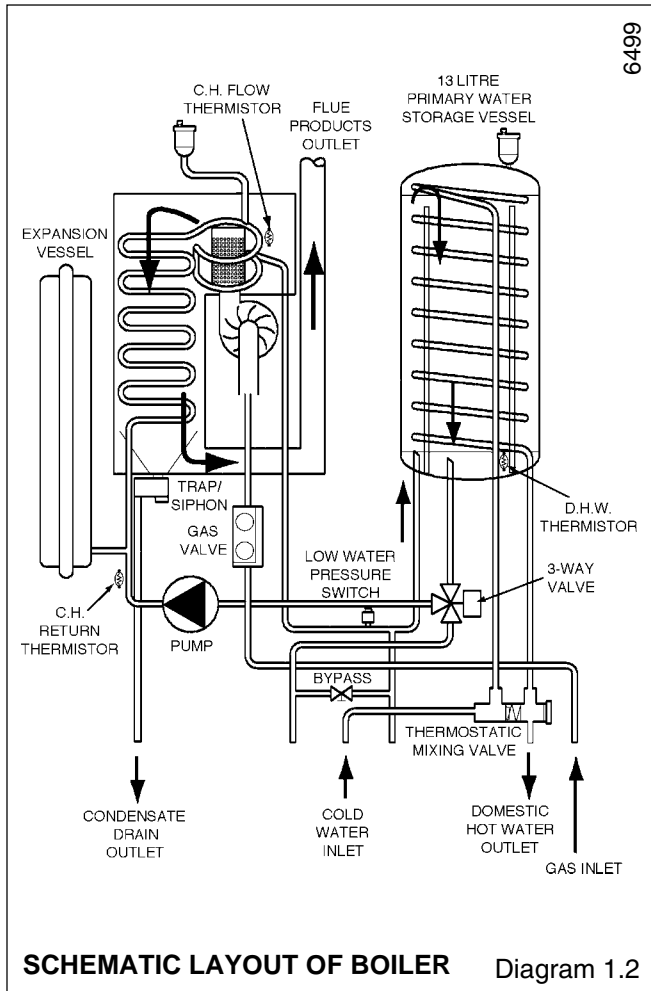

TABLE 1		C.H. Max	D.H.W.Max	MIN
NOMINAL HEAT INPUT GROSS	kW	80 27.5	27.5	8.0
	Btu/h	93,830	93,830	27,266
NOMINAL HEAT OUTPUT	kW	80 24.5	24.5	6.8
	Btu/h	83,600	83,600	23,200
COND. HEAT OUTPUT	kW	80 25.5	25.5	7.7
	Btu/h	87,000	87,000	26,170
BURNER MANIFOLD SUCTION PRESSURE HOT (APPROX)	mbar	80 -4.5	-4.5	-0.5
	wg	-1.8	-1.8	-0.2
BURNER CASING DOOR ON	%CO ₂	80 9.2-9.6	9.2-9.6	9.2-9.6
	CASING DOOR OFF	9.0-9.4	9.0-9.4	9.0-9.4
APPROX. GAS RATE	m ³ /h	80 2.6	2.6	0.7
	ft ³ /h	91.8	91.8	24.7
	m ³ /h	100 2.9	2.9	0.9
	ft ³ /h	102.4	102.4	31.8

TABLE 2

	80	100	
Lift Weight	72kg (158.7lb)	77kg (169.7lb)	
Total Weight (packed)	76kg (167.5lb)	81kg (178.6lb)	
Total Weight (installed)	94kg (207.2lb)	99kg (218.3lb)	
● Gas connection	Rc1/2 (1/2 in BSPT)		
● Heating and return	22mm compression		
● Domestic hot water	15mm compression		
Safety valve	Preset 3bar (43.5lbf/in ²)		
Safety valve discharge	15mm copper		
■ Expansion vessel capacity 7 litres (1.54 gallons)	80	100	
	Water content (heat exch)	2.7 ltr (0.59 gall)	4 ltr (0.88 gall)
	Water content (primary store)	13 ltr (2.86 gall)	12.4 ltr (2.7 gall)
Water content (domestic)	1.3 ltr (0.29 gall)	2 ltr (0.44 gall)	
Charge pressure	0.5bar (7.3lbf/in ²)		
Heating system minimum pressure	0.7bar (10.1lbf/in ²)		
D.H.W Max. working pressure	8bar (150lbf/in ²)		
Domestic hot water flow rate	temp rise 30°C 11.4l/min (2.5gall/min) 13.3l/min (2.9gall/min)		
	35°C 9.8l/min (2.2gall/min) 11.4l/min (2.5gall/min)		
Maximum flow temperature	65°C		
Minimum working pressure	0.1bar		
■ Maximum heating system water content using fitted expansion vessel, pressurised at 1bar.	130 litres (28.6 gallons) at 75°C average system temperature		
Electrical supply	230V~50Hz		
Electrical rating	115W fused 3A		
IP classification	IP40		
Internal Fuse rating	1) Type 2AF 2) Type 2AF 3) Type 3AT		
● Ball valves are fitted in water and gas connections, plus a drain point on all water connections.			
■ For larger systems use an additional expansion vessel.			

3 Flue Location and Ventilation

3.1 Flue Position and Length

There are several flueing options available for the Energysaver Combi, e.g. horizontal, vertical and twin flue.

The standard horizontal flue is fitted onto the top of the boiler using the flue elbow.

See diagrams 3.1 to 3.3 to determine whether a standard flue can be used.

The standard flue can be extended using 1 m long extension kits and 90° elbows. A maximum of 3500mm of extension pipes plus 3x90° bends can be added to the standard horizontal flue length.

NOTE: When extension pipes are used the flue system must be designed to have a continuous fall to the boiler of at least 2.5° to facilitate the removal of condensate.

3.2 Internal Flue Installation

The flue can be installed from inside the building, when access to the outside wall face is not practicable.

3.3 Terminal Position

The minimum acceptable siting dimensions for the terminal from obstructions, other terminals and ventilation openings are shown in diagram 3.4.

The terminal must be exposed to the external air, allowing free passage of air across it at all times.

Being a condensing boiler some plumbing may occur from the flue outlet. This should be taken into consideration when selecting the position for the terminal.

Car ports or similar extensions of a roof only, or a roof and one wall, require special consideration with respect to any openings, doors, vents or windows under the roof. Care is required to protect the roof if made of plastic sheeting. If the car port comprises of a roof and two or more walls, seek advice from the local gas supply company before installing the boiler.

If the terminal is fitted less than 600mm below plastic guttering or less than 450mm below painted eaves or a painted gutter, an aluminium shield 750mm long should be fitted immediately beneath the guttering or eaves.

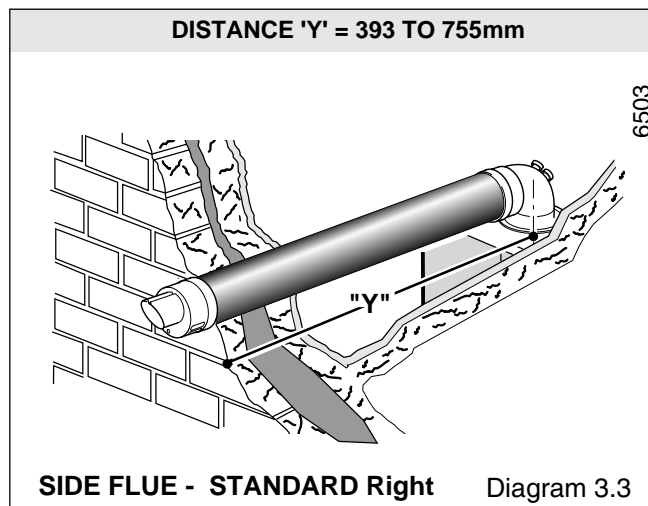
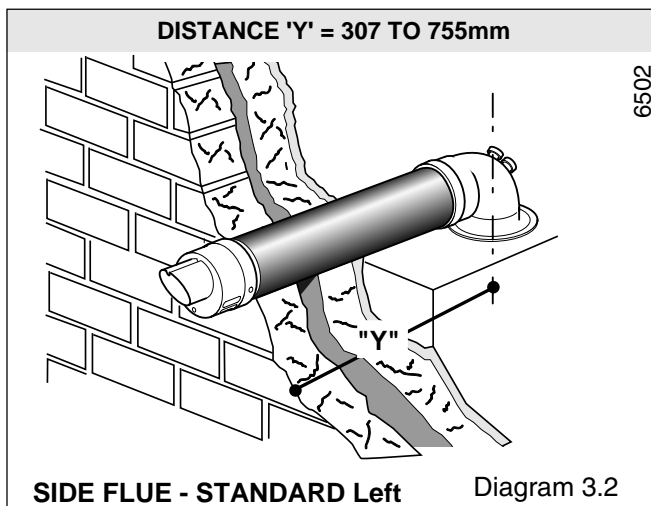
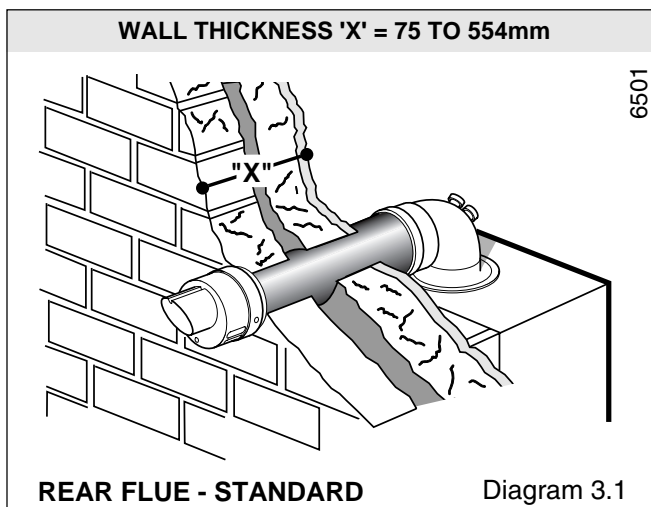

3 Flue Location and Ventilation

3.4 Terminal Guard

A terminal guard is required if persons could come into contact with the terminal or the terminal could be subject to damage.

If a terminal guard is required, it must be positioned to provide minimum of 50mm clearance from any part of the terminal and be central over the terminal.

The guard should be similar to that shown in diagram 3.5.

A suitable guard can be obtained from.

Tower Flue Components

Morley Rd.

Tonbridge

Kent

TN9 1RA.

Their Reference CGD K3 BL.

3.5 Timber Frame Buildings

If the boiler is to be installed in a timber frame building it should be fitted in accordance with the Institute of Gas Engineers document IGE/UP/7/1998. If in doubt seek advice from the local gas undertaking or Hepworth Heating Ltd.

3.6 Room Ventilation

The boiler is room sealed, so when it is installed in a room or space, a permanent air vent is not required.

3.7 Cupboard or Compartment Ventilation

Due to the high efficiency and hence low casing temperature of this boiler, cupboard or compartment ventilation is not necessary.

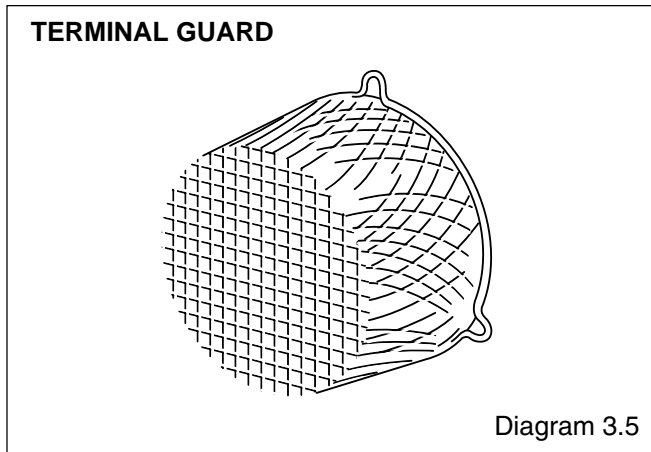

MINIMUM SITING DIMENSIONS FOR FANNED FLUE TERMINALS POSITION

	MM
A DIRECTLY BELOW AN OPENABLE WINDOW, AIR VENT, OR ANY OTHER VENTILATION OPENING	300
B BELOW GUTTER, DRAIN/SOIL PIPE	75
C BELOW EAVES	200
D BELOW A BALCONY OR CAR PORT	200
E FROM VERTICAL DRAIN PIPES AND SOIL PIPES	75
F FROM INTERNAL CORNERS	300*
G ABOVE ADJACENT GROUND OR BALCONY LEVEL	300
H FROM SURFACE FACING THE TERMINAL	600*
I FACING TERMINALS	1200
J FROM OPENING (DOOR/WINDOW) IN CAR PORT INTO DWELLING	1200
K VERTICAL FROM A TERMINAL	1500
L HORIZONTALLY FROM A TERMINAL	300
M FROM EXTERNAL CORNERS	300

Diagram 3.4

* It may be necessary to increase this dimension to prevent staining of adjacent walls depending on weather conditions.

4 Heating System

4.1 General

The boiler is for use in sealed water systems only.

The safety valve is an integral part of the boiler and it cannot be adjusted.

A pressure gauge is incorporated into the boiler to indicate the system pressure.

The circulation pump is integral with the boiler, see diagram 4.1.

4.2 Expansion Vessel

The boiler has an integral expansion vessel with a capacity of 7 litres (1.54 gallons), with a charge pressure of 0.5bar.

The maximum heating system water content using the fitted expansion vessel is 130 litres at an average temperature of 75°C, and charge pressure of 1.0bar.

4.3 Flow Rate

The minimum flow rate through the boiler is 400 litres/hr for ES80 and 470 litres/hr for ES100. This is equal to 20°C differential at maximum heat input.

The system can be fitted with a lockable balancing valve if necessary in the main flow or return pipes shown as valve "A" in diagram 4.2.

4.4 Bypass

The boiler is fitted with a manual bypass, see diagram 4.3. This valve may be adjusted by the installer if necessary to ensure at least 400 litres/hr for ES80 and 470 litres/hr for ES100 flow through the boiler. The boiler is supplied with the bypass open by approximately half a turn and is closed by turning the white screw clockwise. However for systems completely fitted with thermostatic radiator valves or systems of high pressure loss an additional bypass valve must be fitted to the heating circuit to ensure that under no circumstances does the flow rate drop below this level.

An additional bypass valve "B" is shown in diagram 4.2.

4.5 Filling Sealed Systems

Provision for filling the system at a low level must be made. Two methods of filling are shown in diagram 4.4. There must be no permanent connection to the mains water supply, even through a non-return valve.

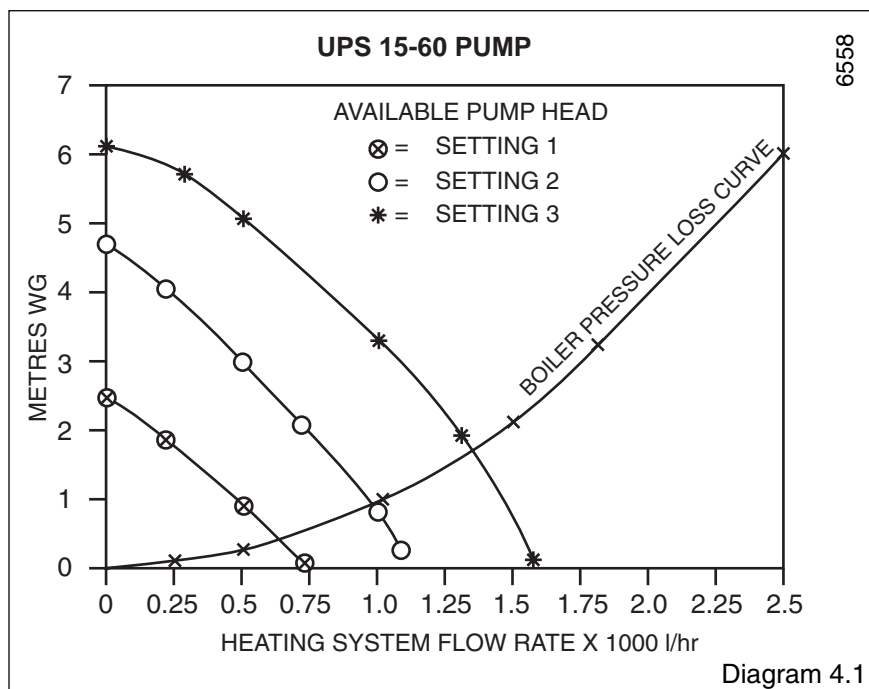

Diagram 4.1

4 Heating System

4.6 Water Treatment

For optimum performance after installation, the boiler and its associated central heating system should be flushed in accordance with BS7593:1992 using a cleanser such as Sentinel X300 or X400, or Fernox Superfloc.

For long term corrosion protection, after flushing, an inhibitor suitable for aluminium heat exchangers should be used. Examples are Sentinel X100 and Fernox Copal.

4.7 Draining Tap

A draining tap must be provided at the lowest points of the system, which will allow the entire system to be drained.

The flow and return isolation valves are provided with drain points for boiler heat exchanger drainage, see diagram 8.1.

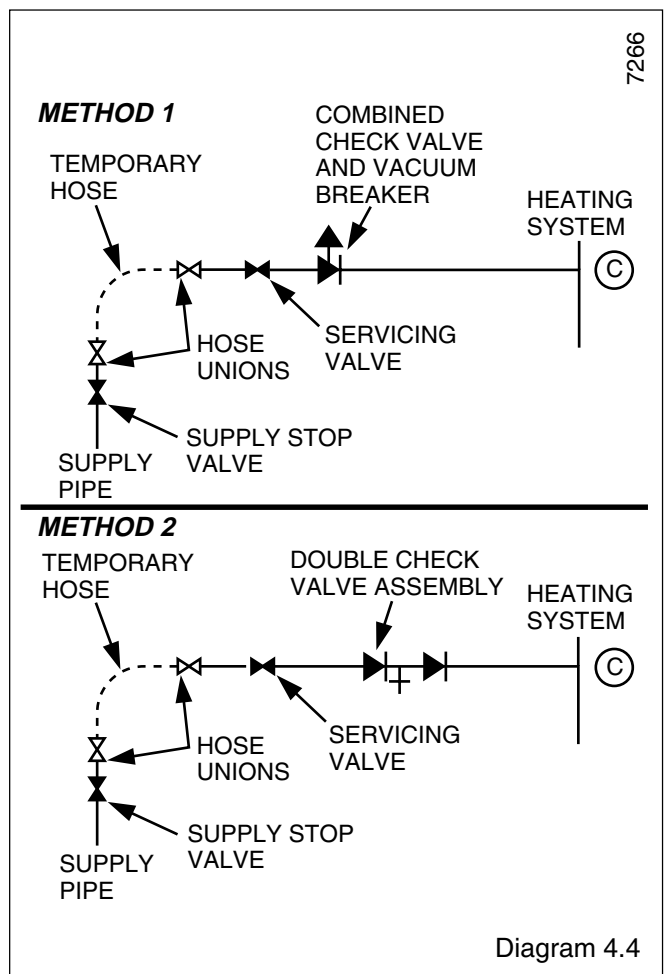
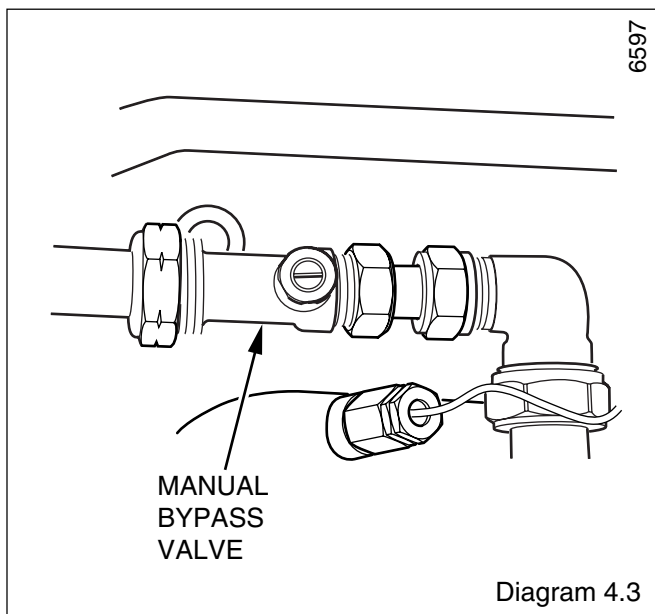
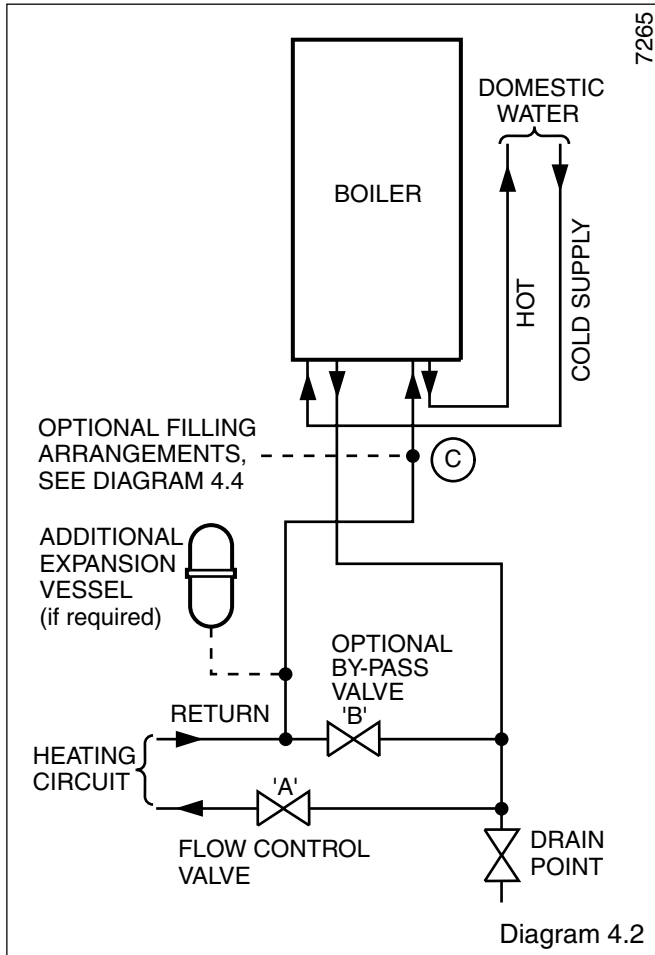

5 Domestic Hot Water System

5.1 Water Pressure

The maximum working pressure of the domestic hot water circuit is 8 bar.

If the cold water supply pressure exceeds the maximum, a pressure reducing valve must be fitted in the supply to the boiler.

5.2 “Hard” Water Areas

The temperatures within the heat exchanger are limited by the boiler control system to minimise scale formation within the hot water pipework. However, in areas where the water is “hard” (i.e. more than 200mg/litre), it is recommended that the hot water setting is adjusted from $\boxed{L_{*}}$ to $\boxed{E_{*}}$ (see section 11.8 and diagram 11.4) and that a scale reducer is fitted.

Refer to the manufacturer’s instructions or consult the local water company for additional advice.

5.3 Domestic Water Flow Rate

The water flow rate is governed to a maximum 12 litre/min by a restrictor fitted into the boiler pipework.

5.4 Mixing Valve

There is a domestic hot water mixing valve fitted to the boiler base and this is factory set at approximately 60°C. This can be adjusted if necessary to supply a lower temperature. Turn the 5mm adjuster anticlockwise to reduce the temperature, see diagram 14.7. The domestic hot water temperature can also be adjusted, see section 11.8.

6 Installation Preparation

6.1 Wall Mounting Pack

The wall mounting pack contains everything required to pre-plumb the boiler, including the wall mounting jig, hanging bracket, wall template, screw pack, room thermostat and safety valve discharge pipe, along with these instructions.

6.2 Wall Template

Remove the wall template from the wall mounting pack and place in the desired position on a flat wall, giving due consideration to boiler clearances, see section 2.

6.3 Flue Hole Cutting

The **standard horizontal flue** is designed with an internal fall of 35mm/metre towards the boiler for disposal of condensate. If the standard flue length alone is being used then the flue hole of diameter 105mm can be cut in the position marked on the wall template.

For **standard side flues** the horizontal flue centre line on the wall template should be extended to the side wall, and the vertical centre of the flue hole marked at 208mm from the back wall.

For installations with external access, a 105mm diameter core drill can be used.

For installations with internal access only a 125mm diameter core drill should be used.

When using extension pipes with the horizontal rear flue, a core drill size of 125mm should be used to allow the extension pieces to slope at 35mm/metre (2.5°) towards the boiler.

For **extended side flues**, the flue hole centre should be determined by extending the dashed inclined line on the template to the side wall. This dashed line is drawn at 35mm/metre (2.5°) rise from the boiler. Where this line reaches the side wall, a horizontal line should be marked. The vertical centre line of the flue should then be marked at 208mm from the back wall, see diagram 6.1.

To allow for the flue passing through the wall at this angle a 125mm hole should be drilled irrespective of internal or external installation.

If necessary remove the wall template whilst drilling the flue hole.

6.5 Wall Mounting Jig and Hanging Bracket Fixing

If previously removed, reposition the wall template over the flue hole and mark the position of the fixing holes for the jig and the hanging bracket.

Drill the four fixing holes using a 7mm dia. drill bit and insert wall plugs supplied.

If gas and/or water pipes are to be plumbed through the rear wall directly into the wall mounting jig holes, the holes must be drilled as marked on the wall template prior to fixing of the wall mounting jig.

Secure the wall mounting jig and hanging bracket using the screws and washers supplied, see diagram 6.2.

6 Installation Preparation

6.5 Pre Plumbing

The wall mounting jig can now be pre-plumbed without the boiler being mounted if necessary. All water, gas and electric connections are on the wall mounting jig with the exception of the condensate drain, the position of which is shown on the wall template for pre plumbing purposes. See sections 9 and 10 for details of gas, water, condensate and electrical connections.

6.6 Unpacking of Boiler Carton

Cut the straps that secure the carton and the boiler to its transit pallet and open the top flaps of the carton. Carefully remove the top packing piece which contains the user control door and place to one side until required. Remove the carton and edge packing. To assist in lifting the boiler it is advisable to remove the casing door by removing the two securing screws.

6.7 Optional Mini Expansion Vessel

As an option a mini expansion vessel can be fitted to the domestic pipework as shown in diagram 6.3.

For ease of installation the vessel should be fitted to the boiler prior to it being lifted to the wall.

Remove the right hand casing panel of the boiler as described in section 12.7.

Remove the $\frac{1}{2}$ " plug fitted into the domestic pipework.

Fit the mini expansion vessel using a suitable thread sealant to make a water tight seal.

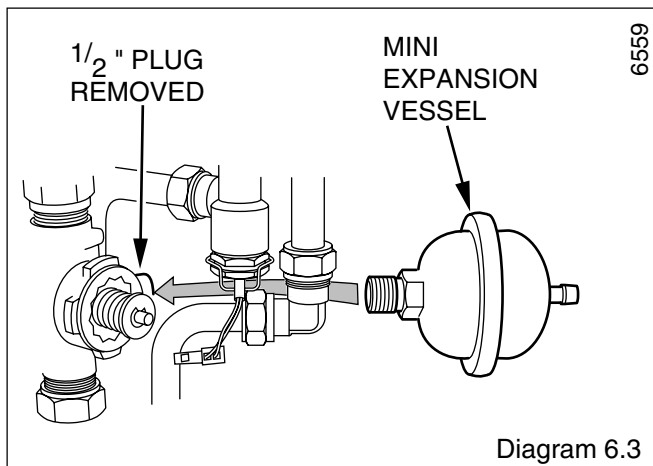

6559

Diagram 6.3

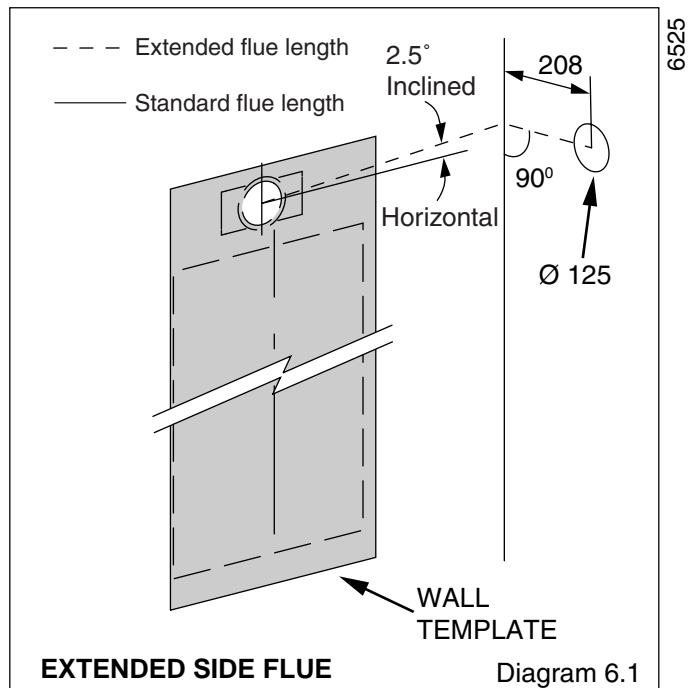

EXTENDED SIDE FLUE

Diagram 6.1

6525

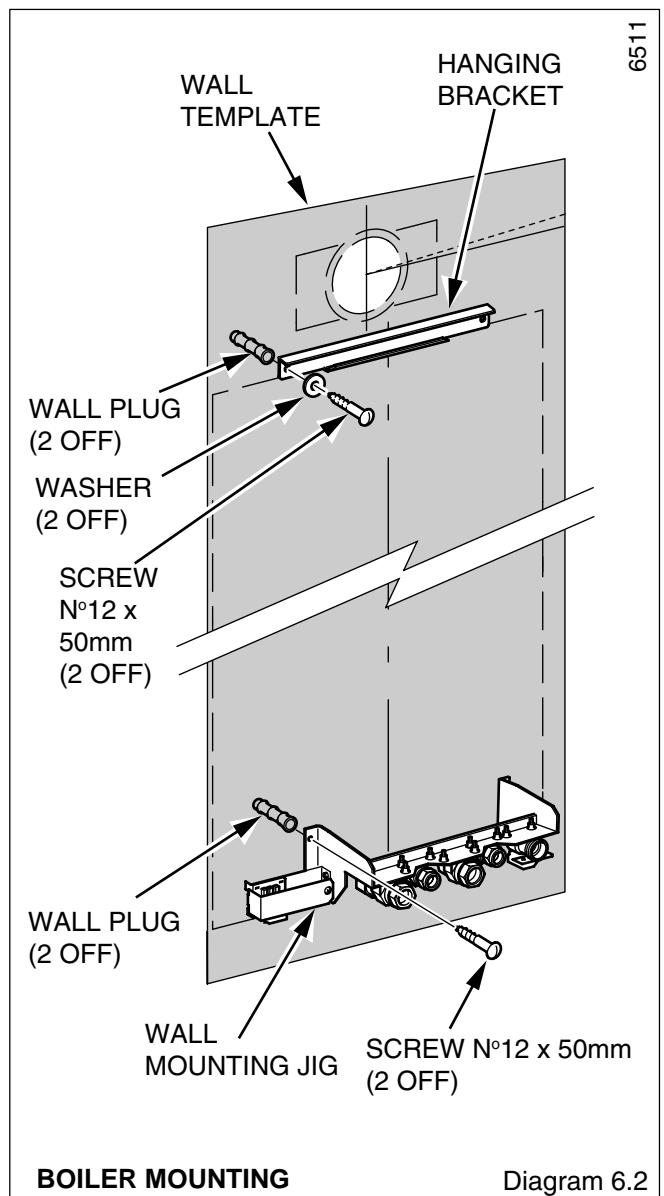

BOILER MOUNTING

Diagram 6.2

6511

7 Flue Preparation

7.1 Flue Length

Note: All dimensions are in mm.

For a rear flue, measure the distance from the outside wall face to the boiler mounting wall. Check that the flue length will be suitable, see diagram 3.1 for a standard flue system.

For a side flue, measure the distance from the outside wall face to the flue outlet centre line of the boiler. Check that the flue length will be suitable, see diagram 3.2 for a left hand flue system or diagram 3.3 for a right hand flue system.

If the measurement exceeds those shown in diagrams 3.1 - 3.3 then one or more extension pipes are required.

7.2 Rear Flue

Mark the air duct assembly and the flue duct at the lengths shown in diagram 7.1 then cut to length, cutting square and removing any burrs.

7.3 Standard Side Flue

Mark the air duct assembly and the flue duct at the lengths shown in diagram 7.2 then cut to length, cutting square and removing any burrs.

7.4 Side Flue With Extensions

Measure the distance from the outside wall to the side of the boiler casing. With the extensions only joined together (i.e. without standard flue piece fitted) cut the end nearest to the boiler, to the dimensions shown in diagram 7.3.

7.5 Flue Assembly

The flue assembly is an entirely push fit design.

The rubber seals should be lubricated prior to assembly.

Remove all burrs from cut pipes.

Diagram 7.4 shows the components supplied in the standard flue kit.

Having cut the air and flue ducts as described in sections 7.1 - 7.4, assemble the flue as follows: the flue can be assembled externally and internally by following sections A & C, or entirely from inside by following sections B & C.

A. External fitting - Fit the rubber sealing collar 'D' into the groove at the outer end of the air pipe 'B'.

Push the air pipe 'B' into the wall until collar 'D' is pushed up against the outside face of the wall.

Ensure that the 'up' label on air pipe 'B' is at the top, i.e. the tab protruding into the hole at the outer end of the pipe is uppermost.

B. Internal fitting - Fit the rubber sealing collar 'D' into the groove at the outer end of the air pipe 'B'.

Fit spacer piece 'E' over air pipe 'B'.

Push the air pipe 'B' through the wall until collar 'D' is clear of the outside face of the wall.

Pull the air pipe 'B' to ensure that collar 'D' is pulled up to the outside wall face.

Ensure spacer piece 'E' is pushed into the wall, see diagram 7.1.

C. Fitting Completion - Fit sealing flange 'F' over the air pipe and against the inside wall face.

From inside fit flue pipe 'A' into the air pipe 'B' ensuring that the groove on the outer end engages in the air pipe tab.

Fit the flue pipe spacer 'C' over the flue pipe 'A' and push inside air pipe 'B'.

Attach any extension pieces necessary.

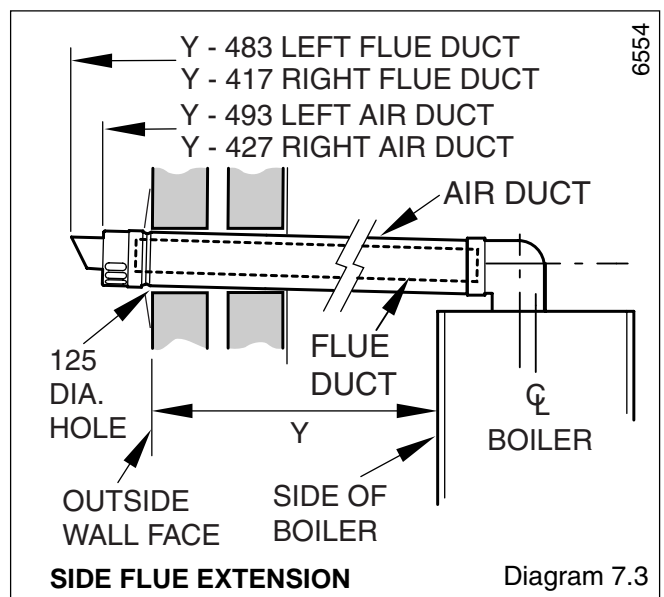
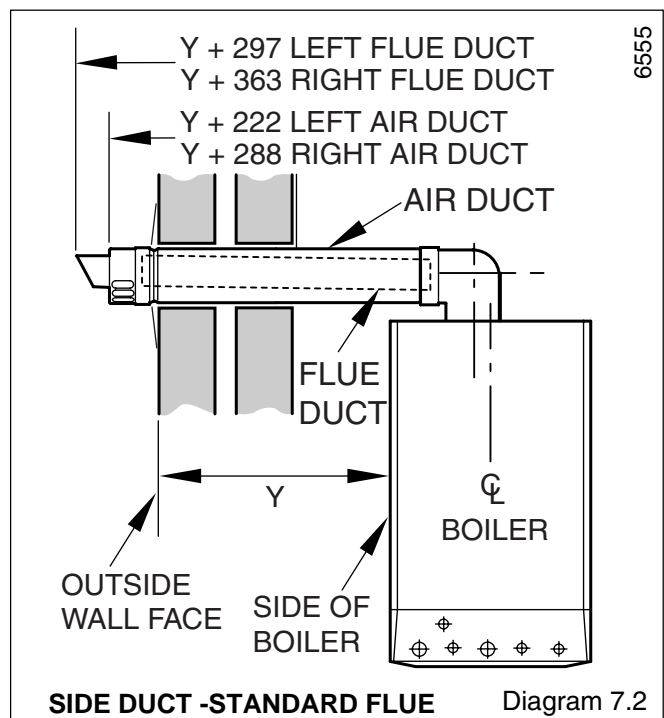
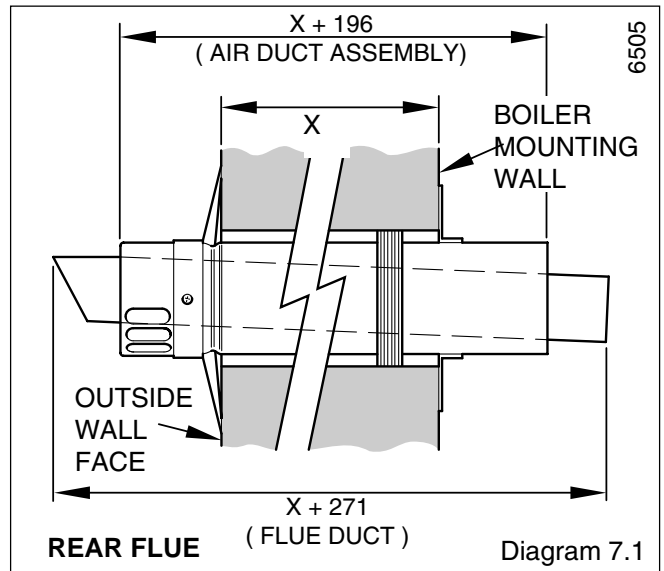

7 Flue Preparation

7.6 Flue Attachment To Boiler

Refer to section 8 and fix the boiler in position prior to completing the flue installation.

Pull off the wire clip on the flue adaptor pipe inside the boiler, see diagram 7.5. Push the flue adaptor pipe downwards into the flue pipe.

Refer to diagram 7.4. Fit rubber dome 'J' to the base of the flue elbow 'G' and place securing ring 'H' over the elbow to rest around the bottom flange of the rubber dome.

Fit flue elbow 'G' to air pipe 'B' and flue duct 'A'. A small amount of lubricant can be applied to the rubber seals in the elbow to facilitate this.

Secure the rubber dome 'J' to the top of the boiler with securing ring 'H' and screws provided.

Push the flue adapter pipe up onto the inner duct of the elbow and secure with wire clip.

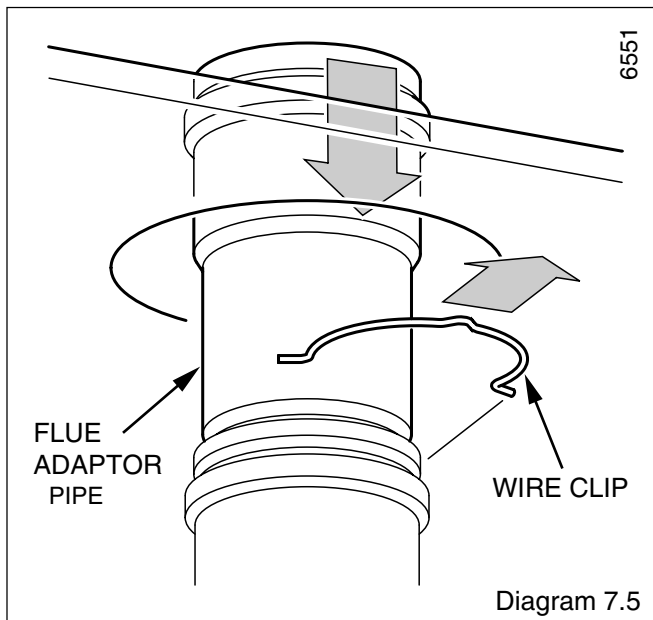
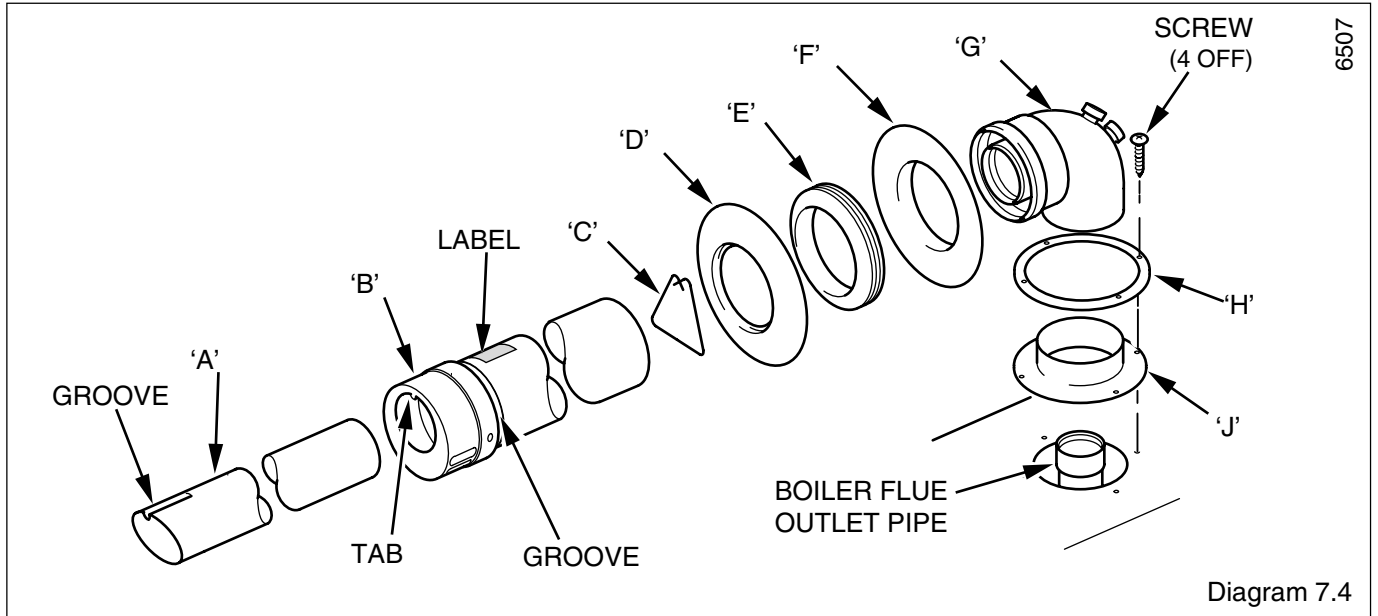

8 Boiler Fixing

Boiler Fixing

Having previously secured the wall mounting jig and hanging bracket to the wall, lift the boiler into position in the following manner. To assist in the lifting of the boiler, remove the casing door.

Lean the top of the boiler slightly to the wall and position just above the hanging bracket. Allow the boiler to slowly move downwards until engaged in the hanging bracket.

Slowly swing the base of the boiler to the wall mounting jig ensuring that the copper tails on the boiler fit into the gas and water isolation valves on the jig, see diagram 8.1. If necessary the gas and water isolation valve clamps can be loosened to ease fitting. Make sure that the isolation valves are secured with the clamps after making good the connections.

Connect the two electrical connector plugs hanging from the boiler into the sockets on the wall mounting jig. The white mains electrical supply socket on the left hand side of the jig and the black auxiliary electrical socket on the right hand side of the jig.

NOTE: Please refer to condensate connection before proceeding, see section 9.4.

Attach the flue as described in section 7.6.

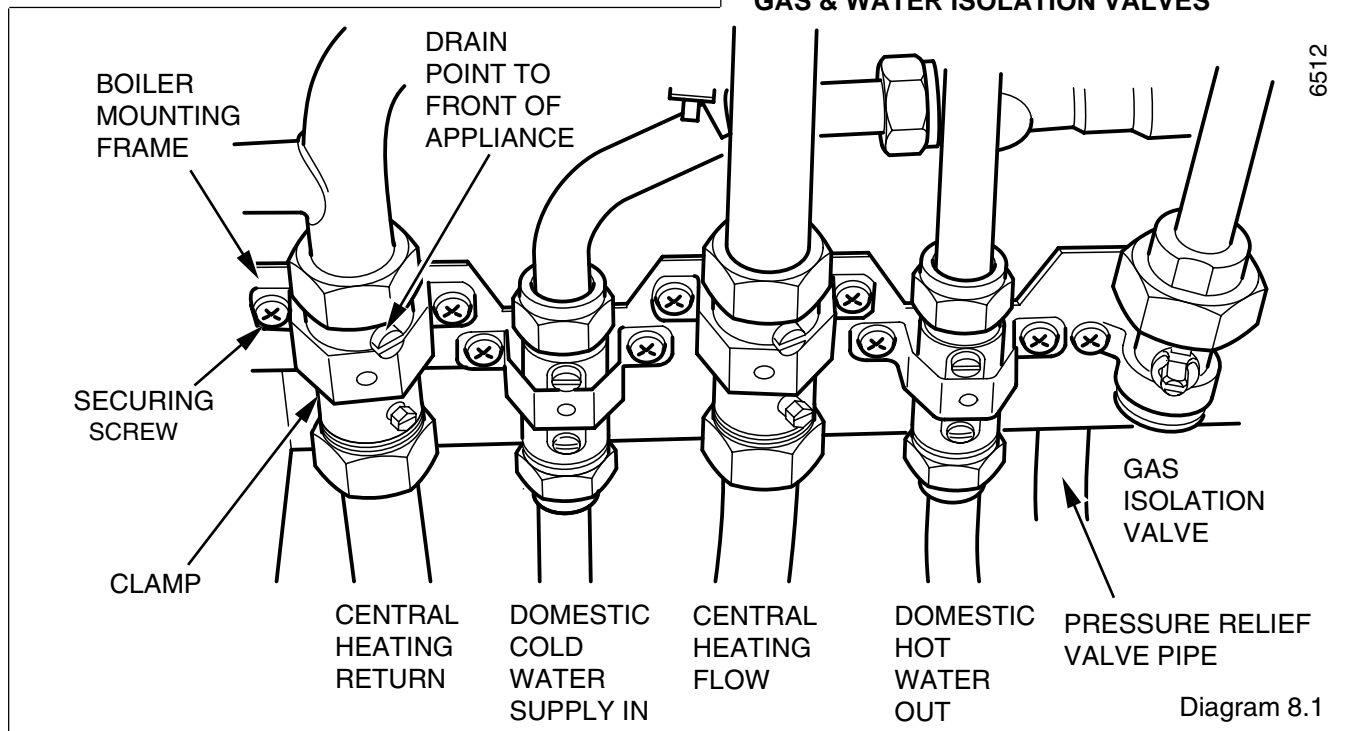
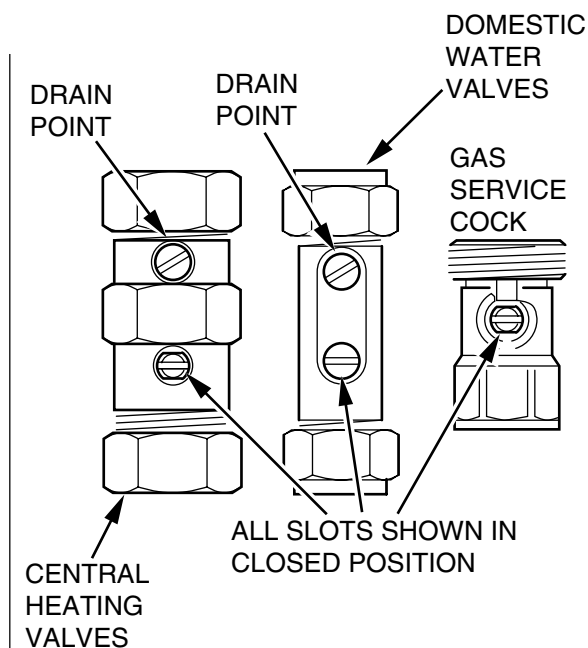

9 Gas, Water, and Condensate Connections

9.1 Gas Connection

The gas supply can be connected from below or through the wall at the rear of the boiler, the position is shown on the wall template.

Refer also to section 1.2.

Make the gas supply connection to the gas isolation valve. Slacken or remove the clamp, as desired, whilst making the connection. Do not subject the gas isolation valve to heat, see diagram 8.1.

9.2 Water Connections

Provision is made for the water connections to be made from below or through an internal wall at the rear of the boiler, the position is shown on the wall template. Copper tail pieces are supplied in the wall mounting pack if required.

Flush out the domestic hot water and the heating systems before connecting to the boiler.

Make the connections to the domestic hot water and heating systems by way of the isolating valves, see diagram 8.1

Slacken or remove the clamps, as desired, while making the connections. Do not subject any of the isolating valves to heat.

9 Gas, Water, and Condensate Connections

Make sure that the drain points on the isolating valves are positioned towards the front of the boiler, also that the drain and operating screw heads are accessible.

9.3 Safety Valve Discharge

WARNING: The pipe from the safety valve must not discharge above an entrance, window or any type of public access area.

A short discharge pipe is supplied loose in the wall mounting pack. This must be extended, using not less than 15mm o.d. pipe, to discharge, in a visible position, outside the building, facing downwards, preferably over a drain.

The pipe must have a continuous fall and be routed to a position so that any discharge of water, possibly boiling, or steam cannot create any danger to persons, damage to property or external electrical components and wiring.

NOTE: To ease future servicing it is advisable to use a compression type fitting to extend the discharge pipe.

9.4 Condensate Connection

The condensate connection is at the bottom of the boiler to the left hand side of the wall mounting jig, see diagram 9.1.

The condensate discharge pipe should have a fall of at least 2.5° away from the boiler.

Condensate should, if possible be discharged into the household internal drainage system. If this is not practicable, discharge can be allowed into the external household drains or a purpose designed soak away.

It is recommended that any external condensate drain pipe is at least insulated and also preferably of larger diameter, to prevent freezing in adverse weather conditions.

The condensate is discharged periodically in 'slugs' by siphonic action.

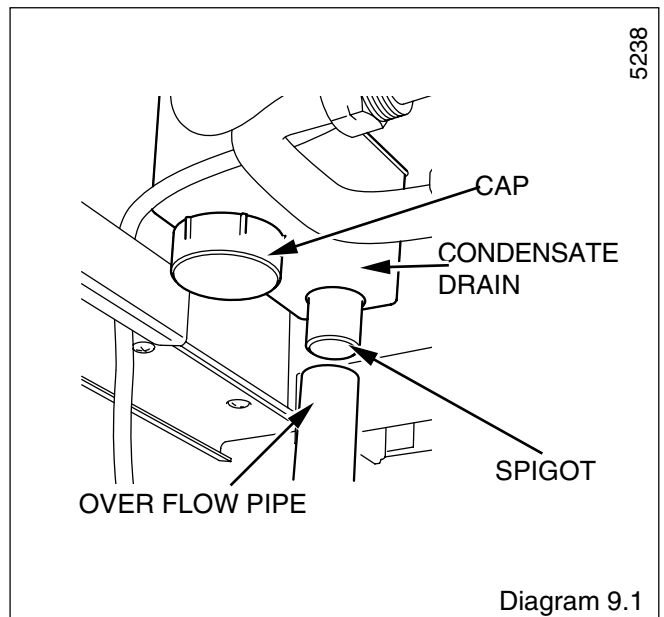

It is recommended that the condensate drain is pre-filled by pouring 250ml ($\frac{1}{2}$ pt) of water into the boiler flue outlet pipe prior to commissioning, see diagram 7.4.

It is not necessary to provide air breaks or extra traps in the discharge pipe as there is already a trap inside the boiler. Fitting an extra trap may cause the boiler siphon to work incorrectly. Refer to British Gas publication "Guidance notes for the Installation of Domestic Condensing Boilers" for advice on the disposal of the boiler condensate.

10 Electrical Connections

10.1 Supply Cable Connection

THIS APPLIANCE MUST BE EARTHED.

CAUTION: To prevent an induced current from switching the central heating on, when not required, it is important that the heating system control cables are separated from the other mains supply cables.

The boiler requires a permanent mains supply through an isolator, see section 1.4.

Any heating system controls must not interrupt the permanent mains electrical supply to the boiler.

Unscrew the mains electrical supply cover plate, situated on the left hand side of the wall mounting jig, see diagram 10.1.

Remove the mains electrical connector socket from the fittings pack and push on to the bracket on the left hand side of the wall mounting jig with the socket pins pointing upwards. Remove the two securing screws and cover from the socket. Using PVC cable of suitable length and rating as stated in section 1.4, connect the mains supply cable to the appropriate terminals of the plug, see diagram 10.2.

Standard colours are, Brown - Live; Blue - Neutral; Green and Yellow - Earth.

The electrical mains supply cable outer insulation must not be cut back external to the connector.

Make the earth cable of a greater length so that if the cable is strained the earth would be the last to become disconnected.

CAUTION: It is essential that the polarity is correct.

10 Electrical Connections

10.2 Heating System Controls

WARNING: Mains electricity must not be connected to the black auxiliary control plug.

All heating system controls must be low voltage or potential free.

It is recommended that the boiler is controlled by a programmer and room thermostat. A suitable room thermostat is supplied in the wall mounting pack.

Thermostatic radiator valves may be installed in addition to the room thermostat.

Note: For further information, see The Building Regulations 1991 - Conservation of fuel and power, 1995 edition - Appendix G, table 4b.

All system controls are wired into the black electrical connector plug situated on the right hand side of the wall mounting jig.

If electrical controls are being used the links between terminals should be removed as necessary as shown in diagram 10.3.

If electrical controls are not being used, DO NOT REMOVE the red and blue links between terminals 1 and 2, and 2 and 3 in the black electrical connector plug.

10.3 Clock/Timer

An integral clock/timer kit can be supplied as an optional extra. Refer to the literature supplied with it, regarding fitting.

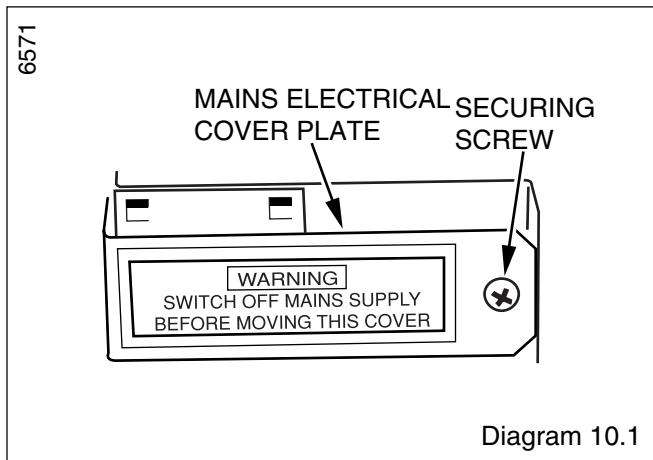

Diagram 10.1

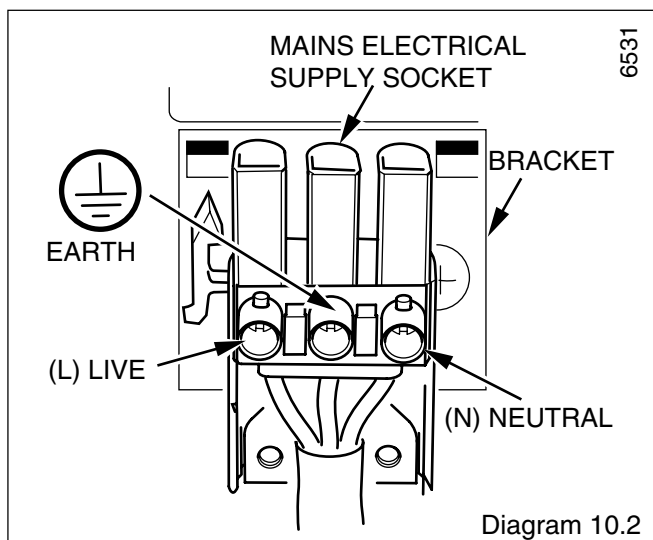

Diagram 10.2

10.4 Frost Thermostat

This boiler has its own frost protection device to protect the boiler. Additional frost protection may be required for exposed pipework. If required, connect a single pole frost thermostat to the appropriate terminals of the black electrical connector plug as shown in diagram 10.3.

10.5 Outside Sensor

An outside sensor can be supplied as an optional extra, see section 11.11. If required, connect to the red and black wires which are pre-wired to terminals 4 and 5 of the control module.

10.6 Cable and Connector Securing

After completing all the connections to the wall mounting jig electrical connectors, secure the cables with the covers, using the screws previously removed.

Connect the boiler connector, and replace the cover plate over the white mains connector, see diagram 10.4.

10.7 Electrical Connections - Testing

Carry out preliminary electrical system checks as below:

1. Test insulation resistance to earth of mains cables.
2. Test the earth continuity and short circuit of cables.
3. Test the polarity of the mains.

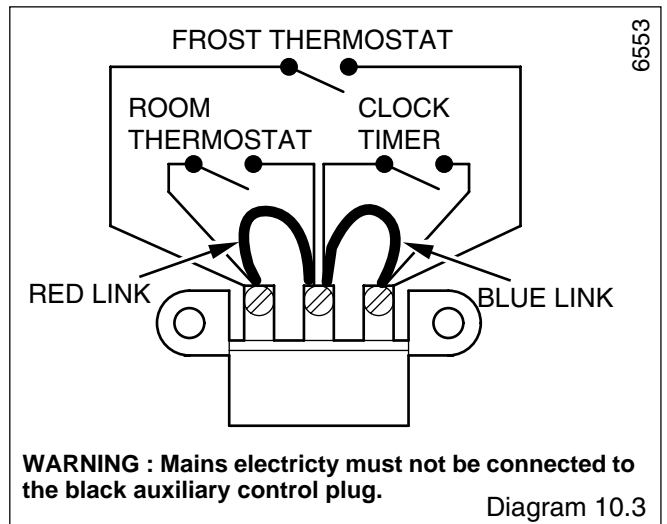

WARNING : Mains electricity must not be connected to the black auxiliary control plug.

Diagram 10.3

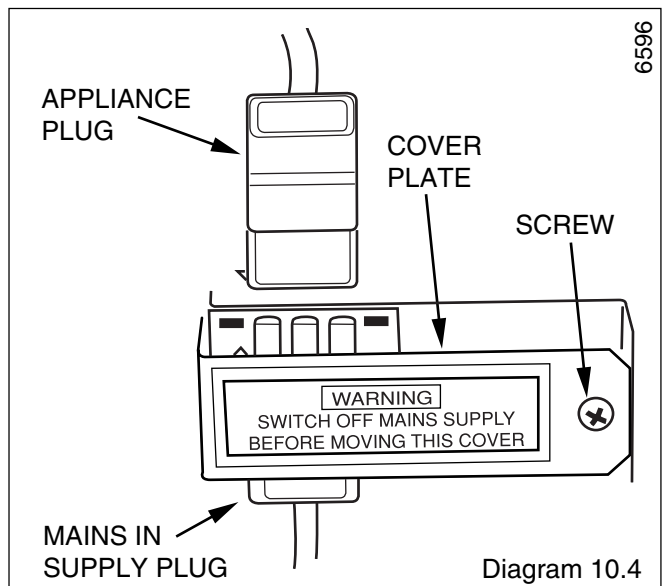

Diagram 10.4

11 Commissioning

Please ensure the "Benchmark" logbook is completed and left with the user.

11.1 Filling Domestic Water Circuit

Fully open any valves in the domestic water supply to the boiler.

Open the two domestic water isolation valves, slots in line with the length of the valve, see diagram 8.1.

Open all hot water taps in turn and close them when water flows. Check for water soundness of the complete domestic water system.

The water flow rate is regulated to 12 litres/min by a restrictor fitted into the boiler pipe work.

11.2 Filling the Heating Circuit

Open the two central heating isolating valves, slots in line with the length of the valve, see diagram 8.1.

Flush, fill and vent the system referring to sections 4.5 and 9.2.

Make sure that the automatic air vents are operating correctly, see diagram 11.1, and that their black caps are **loosely** fitted to allow air to escape.

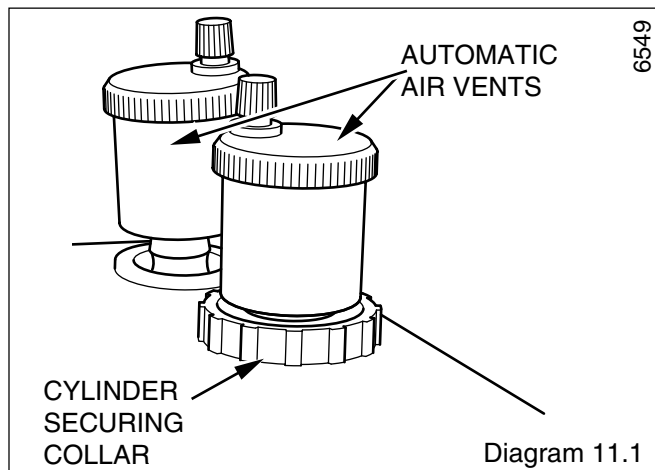

Pressurise the system until the pressure gauge reads at least 1.0bar (14.5lbf/in²), see diagram 1 in Instructions for Use.

Check the heating system and boiler for water soundness.

11.3 Preparation for Lighting

Isolate the boiler from the mains electrical supply.

Test for gas soundness and purge air from the gas supply. Turn on the gas isolation valve, slot in line with the length of the valve, see diagram 8.1.

11.4 Initial Lighting

The lighting procedure of the boiler is fully automated. Check that all external controls are calling for heat. If an integral clock/timer is fitted check that it is correctly programmed and if necessary overridden to provide heat.

Turn on the mains electrical supply. After a short delay the digital display on the fascia should illuminate, see diagram 1 in Instructions for Use.

The fan should start and after a few seconds the ignition will commence.

If the burner fails to light the fan will stop and the display will flash '0' and then '2.'. This indicates the boiler has failed to light, which initially may be due to air in the gas supply line.

Press the 'Reset' button and the boiler will restart, see diagram 1 in Instructions for Use

Flashing digits indicate a fault. Refer to fault finding if any fault persists, see section 13.

After the burner has lit, the boiler will initially heat up the domestic hot water cylinder. This will take approximately four minutes.

After this a pump overrun will operate to ensure that the stored water temperature is not too high.

After a short period the three way valve will switch to central heating.

The boiler will continue firing in central heating mode until the user controls; ie. time clock or room thermostat are satisfied, or there is a demand for hot water.

11.5 Gas Pressure

The gas valve is factory set and should need no adjustment. It should be checked that the supply pressure is 20mb when the boiler is firing at full rate. This can be achieved by turning on several hot water taps and checking the inlet pressure at the tapping on the gas valve shown in diagram 11.2. Turn taps off and disconnect pressure gauge.

NOTE: The burner pressure is altered by the suction of the fan and is modulated according to demand.

11.6 Testing - Heating System

Check that all remote controls are calling for heat. The boiler will fire automatically. Fully open all radiator valves, flow control valve 'A' and additional bypass valve 'B' if fitted, see diagram 4.2.

Balance the radiators as required and if fitted adjust valve 'A' to give the required system differential. Turn off all radiators that can be shut off by the user and adjust the boiler bypass if necessary to achieve less than the maximum differential allowed of 20°C across flow and return.

If this is not possible, a separate system bypass must be fitted and adjusted to achieve less than maximum differential. Refer to section 4.3 and diagram 4.2.

Allow the system to reach maximum temperature then switch off the boiler by isolating from the electrical supply.

Drain the entire system rapidly whilst hot, using the drain tap at the lowest part of the system. Fill and vent the system as described previously in section 11.2.

Lock or remove the handles from controls valve 'A' and bypass valve 'B' if fitted to prevent unauthorised adjustment.

11.7 User Control Door - Fitting

Take the control door, which was removed from the top of the boiler carton and fit the the two brass lugs. Push the lugs into the slots at the bottom of the fascia to engage, see diagram 11.3.

11.8 User Controls and Options

The Energysaver Combi has a multifunctional single digit display and two control buttons labelled 'Mode' and 'Reset', see diagram 1 in Instructions for Use.

The 'Reset' button is used to restart the boiler after a fault condition has occurred, ie. ignition failure, low water pressure or high water temperature.

The 'Mode' button allows the user to view the operating conditions of the boiler, or if necessary change the domestic or central heating temperatures to a preferred setting. The boiler is factory pre-set to supply Domestic hot water up to 65°C and central heating up to 70°C.

11 Commissioning

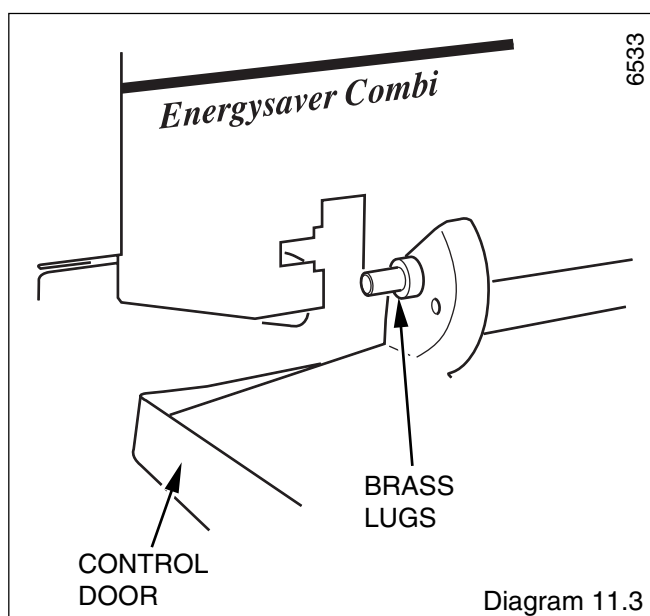
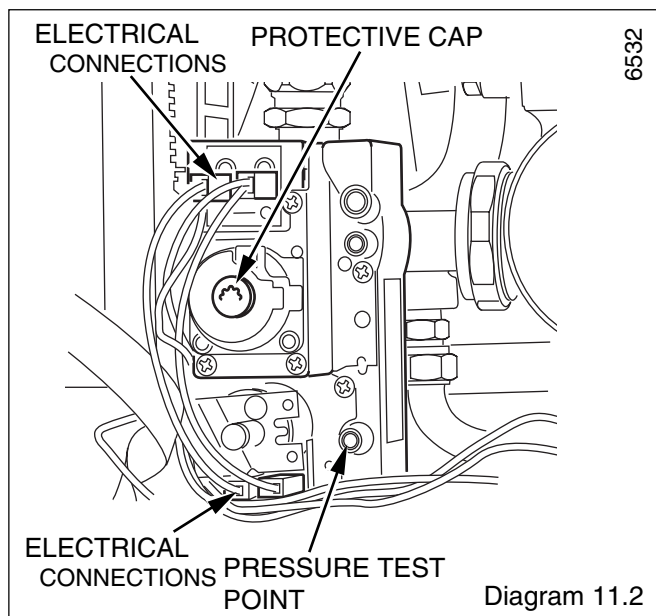

Repeated pressing of the 'Mode' button gives the display sequence shown in diagram 11.4.

If a different option is required, repeatedly press the 'Mode' button until the required symbol is shown, and then press and hold the 'Mode' button for two seconds. The decimal point will flash to confirm selection.

Note: If left the display reverts to show boiler temperature after approximately two minutes.

Temperature Display

The boiler normally shows the operating temperature of the unit on the digital display. However, because the display consists of only one digit, temperature is represented in blocks of ten degrees as follows.

DISPLAY	TEMPERATURE RANGE (°C)
0	Min - 5
1	6 - 15
2	16 - 25
3	26 - 35
4	36 - 45
5	46 - 55
6	56 - 65
7	66 - 75
8	76 - 85
9	86 - Max

6566

The decimal point after the digit signifies that the boiler is firing. This information is also supplied on the inside of the control door.

Temperature Options

There are four domestic hot water and four central heating options to choose from. These options are shown on the digital display by repeated pressing of the 'Mode' button. The sequence is shown in diagram 11.4. The selected options are indicated by a flashing decimal point.

Only one domestic hot water and one central heating option can be selected at any one time.

For adaptive control, see section 11.10.

11 Commissioning

Control Options

There are two control options available: Normal mode and Holiday mode, see diagram 11.4.

Normal mode uses the domestic hot water and central heating temperatures selected.

Holiday mode shuts down the domestic hot water and central heating. However, frost protection and pump exercise programme remain active. To resume normal operation after a holiday period, select 'Normal Mode', .

Note: If an external frost thermostat is fitted 'Holiday Mode' should **not** be selected during periods of cold weather.

Alternatively select setting  to turn off the domestic hot water and turn the central heating off at the programmer or reduce the room thermostat temp to a low setting.

11.9 Servicing Options

There are four options available to the service engineer, which are not to be used by the user, see diagram 11.4. They are as follows.











Installation Mode

This allows interrogation of the appliance by an authorised engineer, via the connection of a P.C.

After using the installation mode, normal operation of the appliance can be resumed by reselecting 'Normal mode', .

Operating Function

The current function that the boiler is performing is shown by a number with a flashing decimal point, see table below.

OPERATING FUNCTION	
DISPLAY	ACTION
	No demand.
	Boiler fan is purging the system.
	Ignition phase.
	Boiler is supplying central heating.
	Boiler is supplying domestic hot water.
	Waiting for the fan to run up to speed.
	Boiler is off after reaching temperature.
	Central heating pump overrun.
	Domestic hot water pump overrun.
	Boiler safety shut down.

6574

Minimum Input Lock

This function allows the service engineer to lock the appliance into delivering minimum heat input to enable accurate combustion analysis.

Maximum Input Lock

This function allows the service engineer to lock the appliance into delivering maximum heat input to enable accurate combustion analysis.

See section 12.6 for details of checking combustion.

Both input locks are not permanent and revert to normal operation after approximately 15 minutes. The boiler can be manually reverted at any time by pressing the 'Reset' button.

NOTE: If left the display automatically reverts to display temperature after approximately two minutes.

11.10 Adaptive Control

Adaptive Control is an advanced control feature that requires the interaction of a room thermostat. It is used in two out of the four central heating options and allows the boiler to optimise the heat output. This enables the boiler to operate at much lower temperatures and hence be more fuel efficient.

If a room thermostat is not fitted when using these modes the boiler will revert to standard modulation at the temperatures given in diagram 11.4.

NOTE: When the boiler fires from cold with the adaptive control active, it fires at low rate for ten minutes before ramping up to full rate.

For details of wiring in a room thermostat refer to section 10.2 and diagram 10.3.

11.11 Outside Sensor

If an outside sensor is fitted the boiler adjusts the flow temperature to compensate for variations in external temperature. Only two central heating options are available which are different to those in diagram 11.4, these are:

 The outside sensor optimises the boiler flow temperature to suit demand. Normal on/off control is retained but a room thermostat is required. This is the preferred option.

 For use in systems with a programmer but no room thermostat. Sets the boiler flow temperature depending on external temperature. During "off" periods on the programmer the flow temperature is reduced by 10°C.



















11.12 Operating Sequence

Refer to diagram 11.4 and press the 'Mode' button until the Operating function is displayed.

11 Commissioning

6563

NOTE:- The SYMBOL  (flashing decimal point) indicates the selected options

		to		BOILER TEMPERATURE (Decimal Point illuminated means boiler is firing)	
Press Mode -				65°C	} Domestic hot water options (select one only)
Press Mode -				55°C	
Press Mode -				For use with a supplementary hot water cylinder	
Press Mode -				OFF	
Press Mode -				55°C with adaptive control	} Central heating options (select one only)
Press Mode -				70°C with adaptive control	
Press Mode -				85°C	
Press Mode -				85°C with continuous pump operation	
Press Mode -				Normal mode	} Control options
Press Mode -				Holiday mode	
Press Mode -				Installation mode	} Servicing options
Press Mode -		to		Operating function	
Press Mode -				Minimum input lock	
Press Mode -				Maximum input lock	
Press Mode		to		Returns to temperature display	

Sequence Chart for Digital Display

Diagram 11.4

11 Commissioning

The operating sequence of the appliance can be checked against the following two tables.

11.13 Pump Exercise Program

After a power cut or every 24 hour in holiday mode the three way valve will switch and the pump will run for one minute to prevent

CENTRAL HEATING SEQUENCE TABLE	
DISPLAY (Operating function)	ACTION
0*	No demand.
	Create demand by switching on timer or room thermostat.
	Three way valve switches to central heating (approx. 15 seconds).
1*	Pump and fan start.
5*	Fan running up to speed.
2*	Gas valve opens and ignitor sparks for 3 seconds. Burner ignites.
3*	Burner runs at ignition rate (70%) for 10 seconds. Rate drops to minimum for 60 seconds. Input adjusts according to heating option selected.
	End of heating demand i.e. room thermostat satisfied.
7*	Burner shuts down and timed pump overrun commences.
0*	No demand. 3 way valve switches back to domestic position (approx 15 seconds).

6572

the components from sticking. This will also occur during normal operating if there is no domestic or central heating demand for more than 24 hours.

11.14 Frost Protection

During periods of no demand the boiler is protected by a frost protection procedure. If the heating outlet temperature falls to 7°C the pump will start. If the heating outlet temperature continues to fall to 3°C the burner is ignited. The burner is extinguished when the heating outlet reaches 10°C, the pump will run for a further 15 minutes. This function primarily protects only the boiler.

If an additional frost thermostat is fitted, switching of this will operate the boiler.

11.15 Instruct the User

Instruct and demonstrate the lighting procedure and advise the user on the safe and efficient operation of the boiler.

Instruct on and demonstrate the operation of any heating system controls.

DOMESTIC HOT WATER SEQUENCE TABLE	
DISPLAY (Operating function)	ACTION
0*	No demand.
	Create demand by turning on a hot water tap.
1*	Pump and fan start.
5*	Fan running up to speed.
2*	Gas valve opens and ignitor sparks for 3 seconds. Burner ignites.
4*	Hot water supplied to thermal store.
	End of hot water demand i.e. hot water turned off.
	Burner modulates to bring thermal store to correct temperature.
8*	Burner shuts down and pump overrun commences.
0*	No demand.

6573

Advise the user on the use and maintenance of any scale reducer and pass on any relevant instructional documents.

Advise that to ensure the continued efficient and safe operation of the boiler it is recommended that it is checked and serviced at regular intervals. The frequency of servicing will depend upon the installation conditions and usage, but in general, once a year should be enough.

Draw attention, if applicable, to the current issue of the Gas Safety (Installation and Use) Regulations, Section 35, which imposes a duty of care on all persons who let out any property containing a gas appliance.

It is the Law that any servicing is carried out by a competent person.

Advise the user that, like all condensing boilers this appliance will produce a plume of condensation from the flue terminal in cool weather. This is due to the high efficiency and hence low flue gas temperature of the boiler.

Advise the user of the precautions necessary to prevent damage to the system, boiler and the building, in the event of the heating system being out of use during frost or freezing conditions.

Advise the user that the permanent mains electrical supply SHOULD NOT be switched off, as the built in frost protection and pump/valve saver program would not be operable.

Reminder - Leave these instructions and the "Benchmark" logbook with the user.

12 Servicing

12.1 General

To ensure the continued efficient and safe operation of the boiler it is recommended that it is checked and serviced at regular intervals. The frequency of servicing will depend upon the particular installation and usage, but in general, once a year should be sufficient.

It is the law that any servicing is carried out by a competent person.

Measurement of the products of combustion can be achieved by connection of a probe to the flue elbow or alternatively to the sample point at the base of the flue outlet pipe inside the boiler, see diagram 12.1.

Before commencing with a service or replacement of parts the boiler should be isolated from the electrical supply and the gas supply should be turned off at the gas isolation valve, see diagram 8.1.

All routine servicing requirements can be achieved by the removal of the front door only. To remove, simply lower the control door and remove the two screws at the bottom of the front door.

Unless stated otherwise any part removed during servicing should be replaced in the reverse order to removal.

Servicing should always include the removal of any debris from the condensate pipe and siphon.

After completing any servicing of gas carrying components, ALWAYS test for gas soundness and carry out a functional test of the controls.

12.2 Combustion Chamber and Heat Exchanger

The Combustion Chamber and Heat Exchanger do not require cleaning during routine servicing. See section 12.11 for major servicing.

12.3 Burner and Fan

Undo the union nut on the injector tube. Lift the tube clear of the injector on the gas valve and then twist the tube and pull downwards to disengage from the fan inlet flange, see diagram 12.2.

Remove Air pressure switch tube, see diagram 12.2.

Remove spark plug lead, see diagram 12.3.

While supporting the fan, remove the wing nut and screw and pull out the fan securing plate, see diagrams 12.3 & 12.4.

Gently lower the fan and burner assembly out of the combustion chamber.

Disconnect the electrical lead from the fan.

Inspect the burner for any signs of damage.

The burner can be cleaned if necessary by washing in warm soapy water and rinsing with clean water. DO NOT use wire or sharp instruments to clean the holes of the burner.

Clean the inlet holes of the fan inlet flange with a soft brush or vacuum cleaner, see diagrams 12.2 and 12.5.

Examine the fan inlet and outlet seals and replace if necessary.

When refitting the fan securing plate, ensure that the dimples are uppermost and that the fork on the plate engages onto the ledge on the Heat Exchanger, see diagram 12.6.

When refitting the injector tube make sure the 'O' ring seal is fitted.

12.4 Spark Electrode

Remove the spark plug lead and two securing screws. Withdraw the spark electrode and viewing window from the combustion chamber, see diagram 12.3.

Inspect the tips for damage.

Clean away any debris and check the spark gap is $3.5 \pm 0.5\text{mm}$, see diagram 12.7.

Check the electrode gasket for signs of leakage and replace if necessary.

12.5 Condensate Drain

Place a container beneath the condensate drain cap.

Carefully remove the cap at the base of the condensate drain trap, see diagram 9.1.

Remove any solids found.

Check for any debris in the outlet pipe of the condensate drain and clean as necessary.

When refitting the cap ensure that a water tight seal is achieved.

Fill the condensate trap as recommended in section 9.4.

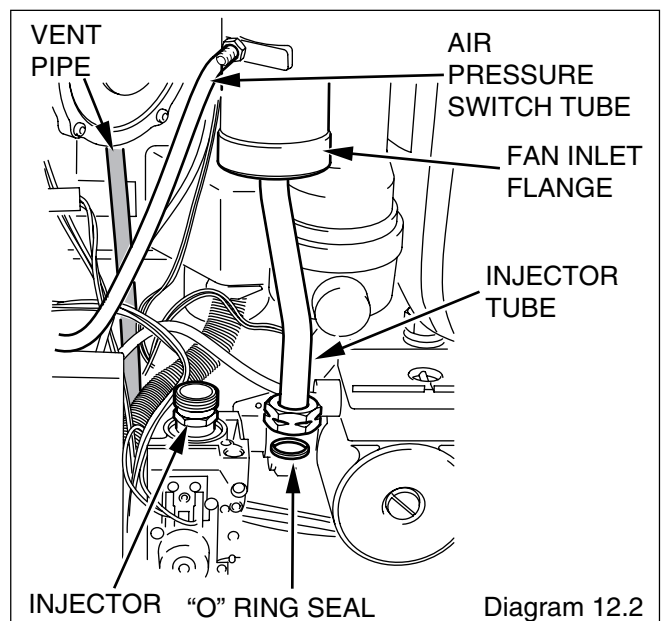
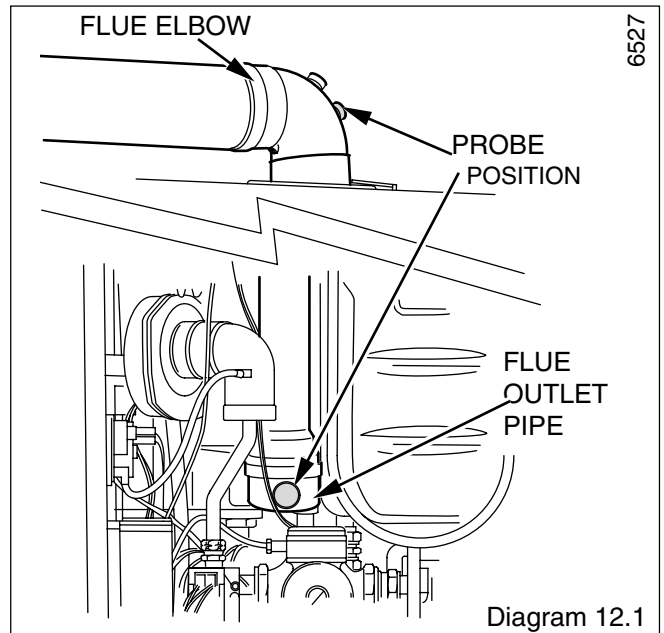

12 Servicing

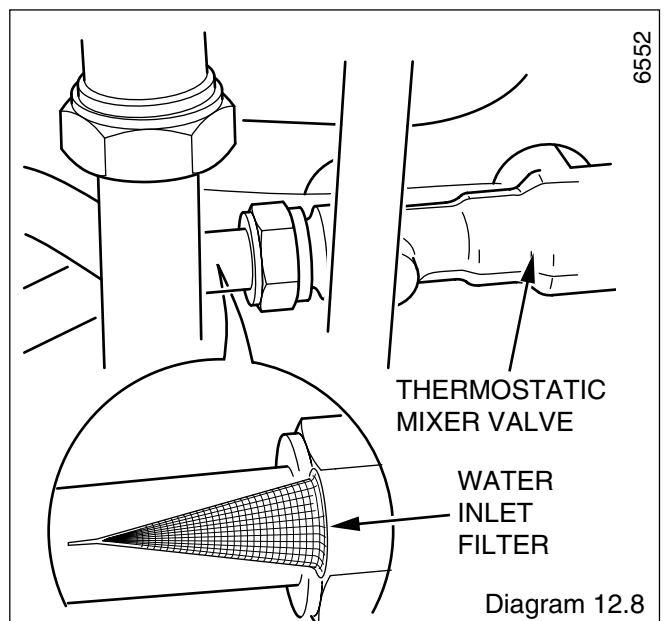
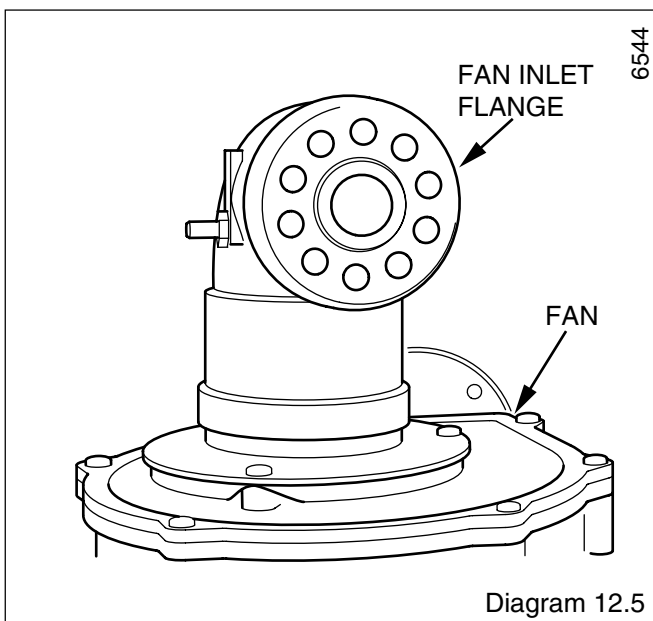
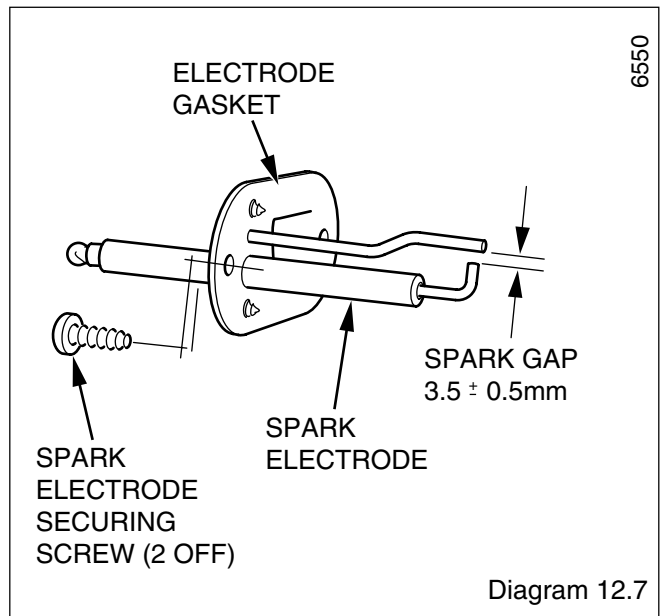
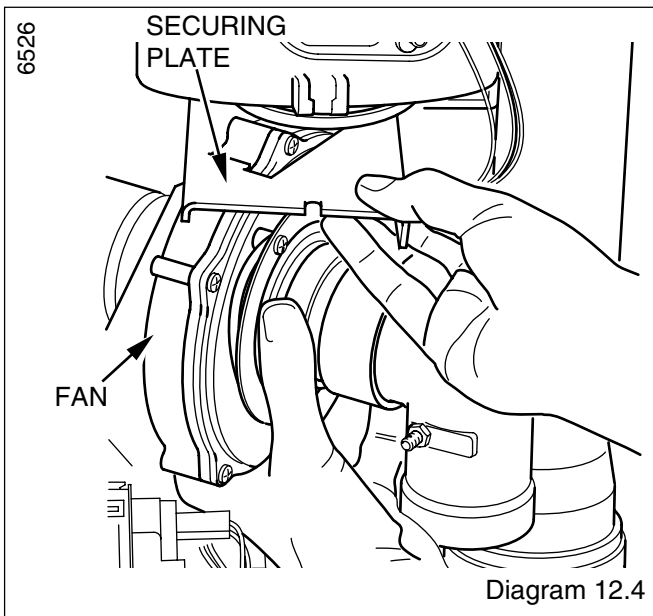
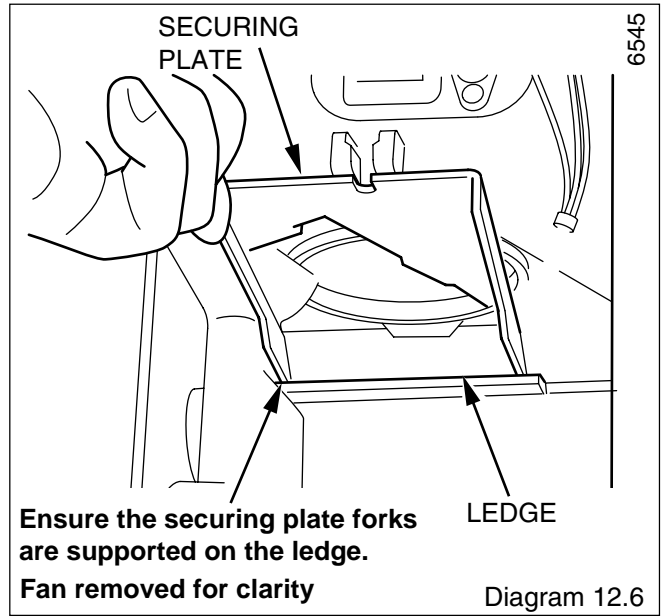
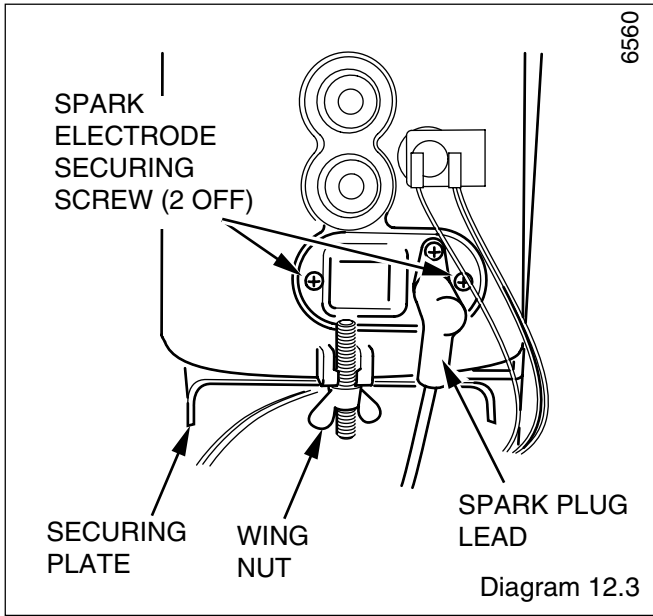

12.6 Combustion Check.

Connect a CO₂ combustion analyser to the test point on the flue elbow if fitted, or alternatively to the sample point at the base of the flue outlet pipe inside the boiler casing, see diagram 12.1.

Turn on the gas isolation valve, see diagram 8.1.

Turn on the electricity supply.

The boiler should fire automatically, but if there is no demand for heat open a hot water tap to create a demand.

Repeatedly press the 'Mode' button on the boiler fascia until the symbol  appears.

Press and hold the 'Mode' button for greater than one second until the decimal point is flashing on the display.

The boiler is now locked at minimum input.

Allow the boiler to stabilise for a few minutes and then check the CO₂ value. See Table 1.

If adjustment proves necessary then proceed as follows.

NOTE: The CO₂ value can only be adjusted at minimum input.

Any adjustment to the gas valve should only be carried out by a qualified person.

Remove the protective cap from the Gas Valve. See diagram 11.2.

Turn the adjuster until the correct CO₂ value is attained.

To check the combustion at full rate repeatedly press the mode button on the boiler fascia until the symbol  appears. Press and hold the mode button until the decimal point on the display flashes.

The boiler is now locked at maximum input.

If necessary several hot water taps should be turned on to deliver maximum flow rate to prevent the boiler from shutting down for overheat protection.

Check the combustion levels of CO and CO₂.

If the combustion is excessive, see fault finding section 13.3.

NOTE: The CO₂ level should not be adjusted in maximum input lock mode.

Press the Reset button to remove the minimum or maximum input lock. Replace caps on sample point and gas valve.

12.7 Cold Water Inlet Filter

If the water flow rate through the appliance has reduced it may be necessary to clean or replace the water inlet filter.

Turn off the electrical supply to the boiler.

Drain the Domestic Hot Water circuit by closing the cold water isolation valve on the wall mounting jig, see diagram 8.1.

Open one or more hot water taps to drain the hot water circuit.

Undo and remove the drain screw on the cold water inlet valve and drain away any remaining water.

Undo the connecting nuts on either end of the water inlet pipe and remove the pipe from the boiler.

Remove the filter situated in the end of the cold water inlet pipe, see diagram 12.8.

Clean the filter, inspect and renew if necessary.

Replace the filter into the cold water inlet pipe. Replace the drain screw in the cold water isolation valve. Replace the water inlet pipe and tighten the unions.

Open the cold water isolating valve and test the Domestic Hot Water circuit for soundness.

12.8 Casing Panel Removal

During major servicing or replacement of parts it may be necessary to remove the boiler side panels to gain access.

Remove the front door and the control door. See section 11.7.

To remove a side panel undo and remove the four screws securing the lower panel brackets to the boiler.

Remove the brackets along with the control door.

Undo and remove the four screws securing each side panel to the boiler, two at the bottom and two at the top.

Pull the panel out at the bottom and off at the top of the boiler.

12.9 Draining of Boiler Heating Circuit

Drain down the Heating Circuit of the boiler only, by closing the heating flow and return isolating valves on the wall mounting jig, see diagram 8.1.

NOTE: These valves are closed when the slots are at right angles to the direction of flow.

Lift the head of the pressure relief valve on the underside of the boiler by twisting and allow the boiler circuit to drain. Complete draining by removing the drain screws from the isolating valves and drain the water into a suitable receptacle.

After servicing or replacing parts, open the heating flow and return isolating valves and refill, vent and pressurise the heating circuit. See section 11.2.

Check for leaks.

12.10 Draining of Boiler Hot Water Circuit

Drain the Domestic Hot Water circuit by closing the cold water isolation valve on the wall mounting jig.

Open one or more hot water taps to drain the hot water circuit.

Undo and remove the drain screw on the cold water isolation valve and drain away any remaining water, see diagram 8.1.

After servicing or replacing parts, replace the drain screw, open the cold water isolation valve and slowly open a hot water tap to remove air. Close the hot water tap and check for any leaks.

ATTENTION!

When carrying out a combustion check or replacing the gas valve, please refer to the gas valve replacement instructions for the gas valve setting procedure.

12 Servicing

12.11 Heat Exchanger - Major Servicing

Refer to Fault Finding sections 13.1, (fault code **D** and **B**.) and 13.4 before carrying out a major service of the heat exchanger.

If it is suspected that the heat exchanger has become partially blocked internally, proceed as follows.

Remove the burner and fan as described in section 12.3.

Remove the wire clip from the internal flue adaptor, see diagram 7.5.

Push the adaptor pipe downwards into the boiler flue pipe, disengaging it from the flue elbow.

Remove the boiler flue pipe.

Check for any blockage in the boiler flue pipe and remove any debris.

Check for any blockage in the casting flue outlet orifice and remove any debris.

Place a suitable container below the condense drain and remove the cap. See section 12.5.

Using a suitable spanner, remove the heat exchanger top panel nuts, see diagram 12.9. Take care when removing the nuts not to drop them behind the heat exchanger.

Carefully prise open the boiler top, making sure that the washers are retained on removal.

Replace the boiler flue pipe.

Place a water hose into the top of the heat exchanger, taking care not to damage the insulation to the rear, see diagram 12.10.

Thoroughly flush the heat exchanger from above and collect the water and any debris in the container beneath the condense drain.

Flush the heat exchanger until the water appears clear at the condense drain.

Check the condition of the heat exchanger top gasket and replace if necessary.

Rebuild the boiler.

Repeat the combustion test as detailed in section 12.6.

If the combustion is still unacceptable then the heat exchanger will need to be replaced. Refer to section 14.21 and remove the heat exchanger.

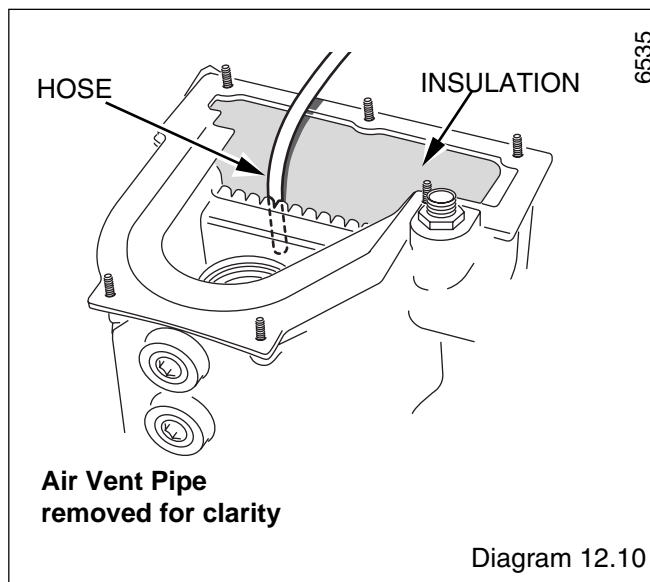
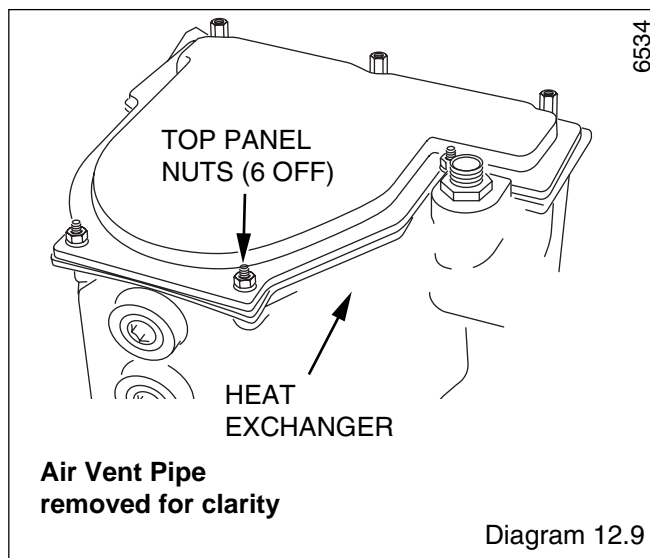

13 Fault Finding

6576

KEY	
Red	r
Black	b
Blue	bl
Brown	br
Green	gr
Yellow	y
Green/Yellow	g/y
White	wh
Orange	or
Grey	gy

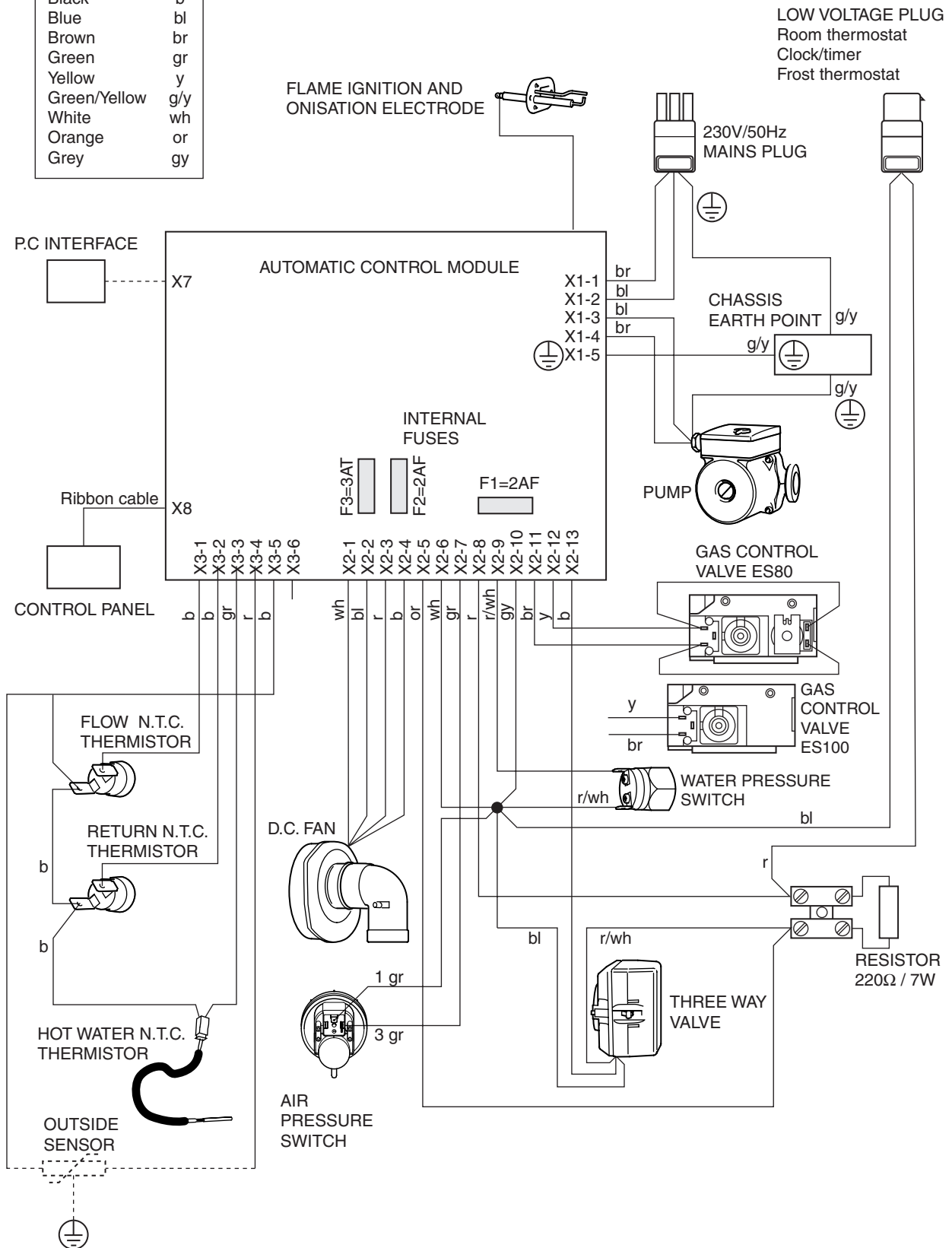

Schematic Wiring Diagram

Diagram 13.1

13 Fault Finding

13.1 Digital Display - Fault Codes

If a fault has occurred during operation of the boiler the display will start flashing.

Two numbers will alternate to show what type of fault has occurred.

The second number has a decimal point after it.

Fault Code = 0 and 0.

There is a flame signal without there being a flame present.

Press the reset button.

If the fault recurs, check the ignition electrode and wire.

Check to see if there is 24V a.c. on the gas valve.

If there is 24V a.c. at the gas valve then replace the Automatic control module, see section 14.4.

After replacing the Automatic Control Module, press the "reset" button and check that the boiler functions correctly. Check that flames extinguish correctly and that after heating demand is complete there is not 24V a.c. present at the gas valve.

Fault Code = 0 and 2.

There is no flame ionisation.

This fault code may appear on commissioning the boiler and may simply be due to the presence of air in the gas line.

Press the reset button and the ignition phase will be repeated.

If the problem recurs, then proceed as follows:

Check that the gas supply to the boiler is turned on.

Check that during the ignition phase there are sparks present at the electrode.

Check that the spark gap of the electrode is correct, see section 12.4.

Check that the resistance of the ignition wire is less than 1000 ohms. If the resistance is too high, change the lead. See section 14.3.

Re-check to see if sparks are present at the electrode. If not check the electrode and change if necessary, see section 14.2.

If there is still no spark at the electrode then the Automatic Control Module needs replacing, see section 14.4.

If the burner lights but the flame is not detected, the CO₂ level may be too low to sustain combustion. Refer to section 12.6. Try turning the adjustment screw clockwise to increase the CO₂ content. If the burner flame is still not detected, then the Automatic Control Module needs replacing. Refer to section 14.4.

If the gas valve setting has been adjusted in any way, the CO₂ value must be reset to the correct value. See section 12.6.

Fault Codes = 0 and 3., 0 and 5., 0 and 6., 0 and 7., 1 and 1., 1 and 3., 1 and 4., 1 and 5., 1 and 6., 1 and 7., 4 and 1., 4 and 2. and 6 and 0.

There is an internal fault in the Automatic Control Module.

Try pressing the "reset" button.

If the fault is not cleared, the Automatic Control Module should be replaced. Refer to section 14.4.

Fault Codes = 0 and 4.

Power supply has been interrupted.

This fault code may appear on first commissioning the boiler, or if the power is interrupted while the boiler is in operation.

Press the "reset" button.

If the fault code is not removed then an internal fault has occurred in the Automatic Control Module.

Refer to section 14.4 and replace the module.

Fault Code = 2 and 4.

The heating flow thermistor and heating return thermistor are connected the wrong way round.

Exchange the thermistor positions or their wiring.

Fault Code = 3 and 0.

There is excessive temperature difference between the flow and return thermistors.

Check that the pump is functioning correctly.

Check that the system is not air locked.

Check that the flow rate through the installation is high enough. Refer to section 4.3.

Fault Code = 3 and 1.

The heating flow thermistor is short circuited.

Check the wiring between the thermistor and the Automatic Control Module for a short circuit.

If the wiring is sound, change the thermistor. Refer to section 14.8.

Fault Code = 3 and 2.

The heating return thermistor is short circuited.

Check the wiring between the thermistor and the Automatic Control Module for a short circuit.

If the wiring is sound, change the thermistor. Refer to section 14.9.

Fault Code = 3 and 5.

The heating flow thermistor is too resistant.

Check that the wiring has not become disconnected

If the wiring is sound, change the thermistor. Refer to section 14.8.

Fault Code = 3 and 7.

The heating return thermistor is too resistant.

Check that the wiring has not become disconnected.

If the wiring is sound, change the thermistor. Refer to section 14.9.

Fault Code = 0 and 8.

The Air pressure switch has not closed.

Check that the air pressure switch is functioning correctly. Switch off the electrical supply to the boiler.

Remove the sensing pipe from the fan elbow and gently suck on the pipe. The air pressure switch should click shut. Immediately crimp the sensing pipe and note whether the air pressure switch holds pressure. A new air pressure switch is required if under these conditions the switch drops to open circuit within a few seconds of crimping the pipe. See section 14.22 for replacement.

Reconnect the sensing pipe to the fan elbow and switch on the electric mains supply. If the boiler does not fire check the following.

Check that the condense drain is not blocked and backing up into the heat exchanger. See section 12.5 for instructions on cleaning.

Check for any obstruction to the flue system internally.

Check the fan and burner cleanliness as in section 12.3.

13 Fault Finding

If after checking all previous points the error code is still present, this suggests that the heat exchanger has become partially blocked. See section 12.11 for major service of heat exchanger.

Fault Code = 2 and 8.

The fan is stationary or there is no fan speed signal.

Check the wiring to the fan.

Check the fan and replace as necessary. See section 12.3 for fan removal.

Fault Code = 2 and 9.

The fan is stationary and open circuit.

Check the wiring to the fan.

Fault Code = 1 and 2.

There is insufficient water pressure in the heating circuit.

Check that there is sufficient water pressure and adjust if necessary to 1.5 bar. Press the "reset" button. If the fault persists check the water pressure switch for continuity. If it is open circuit then replace the water pressure switch, referring to section 14.17.

If the water pressure switch is OK, check the 24V a.c. fuse on the Automatic Control Module (3.15A).

Fault Code = 1 and 8.

The heating flow thermistor is detecting a temperature in excess of 100°C.

Check that the pump is functioning correctly.

Check that the system is not air locked.

Check that the flow rate through the installation is high enough. Refer to section 4.3.

Fault Code = 1 and 9.

The heating return thermistor is detecting an excessive temperature.

Check that the pump is functioning correctly.

Check that the system is not air locked.

Check that the flow rate through the installation is high enough. Refer to section 4.3.

Fault Code = 2 and 5.

The rate of temperature rise measured by the heating flow thermistor is too high.

Check that the pump is functioning correctly.

Check that the system is not air locked.

Check that the flow rate through the installation is high enough. Refer to section 4.3.

13.2 Central Heating

If the central heating fails to operate, or the temperature provided is poor, check the following:

Check that all external controls are calling for heat.

Check that the boiler controls are set correctly, see section 11. Increase temperature or return to 'Normal mode' , if necessary.

If there is still a problem, check that no domestic hot water taps are dripping. A dripping tap can prevent the boiler from operating in the central heating mode. Repair any leaking taps as necessary.

13.3 Thermistor Characteristics

All three thermistors used on the boiler can be checked for accuracy against the chart below if their performance is suspect.

Temperature °C	Resistance (Ohms)
0	35400
10	22500
20	14700
25	12000
30	9835
40	6712
50	4672
60	3311
70	2388
80	1749
90	1300
100	980
110	749

NOTE: That there is no error message displayed for a fault involving the Domestic Hot water thermistor.

The performance of the thermistor should be checked both at hot and cold temperatures.

13.4 Combustion

If the combustion CO₂ measured during servicing in section 12.6 is too high and cannot be adjusted, or the CO levels measured at full rate are unacceptable, then the following possibilities should be investigated and cured.

A. Check the flue system has been correctly installed and that both air and flue ducts are unobstructed internally, see section 7.5.

B. Ensure that correct terminal clearances are observed and that product recirculation is impossible, see section 3.3.

C. Ensure that the condensate drain is not blocked. Refer to section 12.5 for cleaning of the condensate drain and section 14.23 for removal if faulty.

D. Check the condition of the burner and clean or replace as directed in section 12.3.

E. Check and clean the air inlet to the fan and check that the seals are in good condition as directed in section 12.3.

F. If after checking all previous points the heat exchanger may have become partially blocked, see section 12.11 for major servicing of the heat exchanger.

13.5 Operating Procedure

Refer to section 11.12 if necessary to check for correct operation of the central heating and domestic hot water.

14 Replacement of Parts

14.1 General

Replacement of parts must be carried out by a competent person.

Before replacing any parts the boiler should be isolated from the mains electric supply and the gas should be turned off at the service cock on the boiler, see diagram 8.1.

Unless stated otherwise parts are replaced in the reverse order to removal.

After replacing any parts always test for gas soundness and if necessary carry out functional test of the controls.

For replacement of parts the front casing of the boiler will need to be removed, see section 12.1.

14.2 Spark Electrode

Replace the spark electrode as described in section 12.4.

14.3 Ignition Lead

Pull the spark plug style connector off the spark electrode and the spade connector connected to the top of the grey ignition coil.

14.4 Automatic Control Module

Pull the spark plug style connector of the ignition lead off the spark electrode.

Carefully remove the ribbon wire from the display connection on the front face of the unit.

Undo and remove the retaining screw from the top corner of the module.

Pull the Automatic control module forwards and upwards out of its bracket and remove the electrical connections from the underside of the module.

Remove the ignition lead from the module and push onto replacement unit.

Note that the electrical connections are unique to prevent incorrect fitting.

The Ribbon wire connection must be fitted to the lower socket on the module marked 'DISPLAY'.

14.5 Three Way Valve Head

Refer to diagram 14.1.

The three way valve head can be replaced as a separate item to the body if necessary.

Depress the location button on the front of the unit.

Twist the valve head top towards the front of the boiler and remove from the body.

Remove the electrical plug.

The replacement unit must be offered to the body in a rotated position and pushed to the upright position on the valve body.

14.6 Three Way Valve

Refer to section 12.9 and drain the boiler heating circuit.

Remove the three way valve head as described in section 14.4.

Disconnect the Central Heating return pipe from the water cock and loosen the clamp, see diagram 8.1.

Remove the two screws from the return pipe flange beneath the boiler.

Remove the gas pipe.

Remove the domestic hot water pipe.

Undo the left hand nut from the bypass valve, see diagram 4.3.

Remove the pump. See section 14.14.

Undo the compression fittings on the three way valve body, pull the return pipe down and remove the valve.

Fit the replacement valve and replace pipework.

Open the isolating valves on the flow and return connections and refill, vent and pressurise the boiler.

Check for leaks.

14.7 Domestic Hot Water Thermistor

Refer to diagram 14.2.

Remove the three way valve head as described in section 14.5.

Remove the thermistor retaining clip.

Pull the thermistor downwards and out of its pocket.

Unclip the connecting plug and remove the thermistor.

Fit replacement thermistor ensuring that it is pushed fully into the pocket and secure with the retaining clip.

Note that the use of a heat sink compound is not required.

Carry out a functional test of the controls.

14.8 Heating Flow Thermistor

Refer to diagram 14.3.

The heating flow thermistor is situated on the front of the combustion chamber directly above the spark electrode.

Remove the electrical connections from the thermistor.

Undo and remove the screw and securing bracket.

Fit the replacement thermistor using the heat sink compound supplied.

Note that the polarity of the wiring to thermistors is unimportant.

14.9 Heating Return Thermistor

Refer to diagram 14.4.

The heating return thermistor is located on the pipe running from the pump to the heat exchanger.

Remove the thermistor clip by pulling it forwards from beneath the pipe.

If this thermistor clip is tight it may be necessary to remove the pump for easier access. See section 14.14.

Remove the thermistor and clip from the boiler.

Disconnect the electrical connections from the thermistor.

Push the thermistor out of its clip.

Push the replacement thermistor into the clip and apply heat sink compound supplied.

Ensure that the thermistor is correctly located on the flat on the return pipe and push the thermistor clip into place.

Note that the polarity of the wiring to thermistors is unimportant.

14.10 Gas Injector

Remove the injector pipe as described in section 12.3.

Undo and remove the injector from the outlet of the Gas valve, see diagram 12.2.

Fit replacement injector into gas valve using a suitable sealant.

Do not over tighten.

14 Replacement of Parts

14.11 Gas Valve

Remove the injector pipe as described in section 12.3.

Remove the gas injector as described in section 14.10.

Remove the electrical connections from the gas valve, see diagram 11.2.

Undo the gas pipe nut from beneath the base panel.

Undo and remove the two securing screws from beneath the base panel.

Remove the gas valve.

After replacing the gas valve the combustion CO_2 will need to be checked and adjusted if necessary, see section 12.6.

14.12 Fan

Remove fan as described in section 12.3.

14.13 Burner

Remove fan and burner as described in section 12.3.

14.14 Pump

Refer to section 12.9 and drain the boiler heating circuit.

Undo the pump union nuts.

Unscrew the electrical cover from the pump and remove wiring.

Fit the new pump and refill, vent and pressurise the boiler.

Check for leaks.

14.15 Pressure Relief Valve

Refer to section 12.9 and drain the boiler heating circuit.

Undo the pressure relief valve unions and remove from the pipework.

Fit new pressure relief valve.

Refill, vent and pressurise the boiler.

Check for leaks.

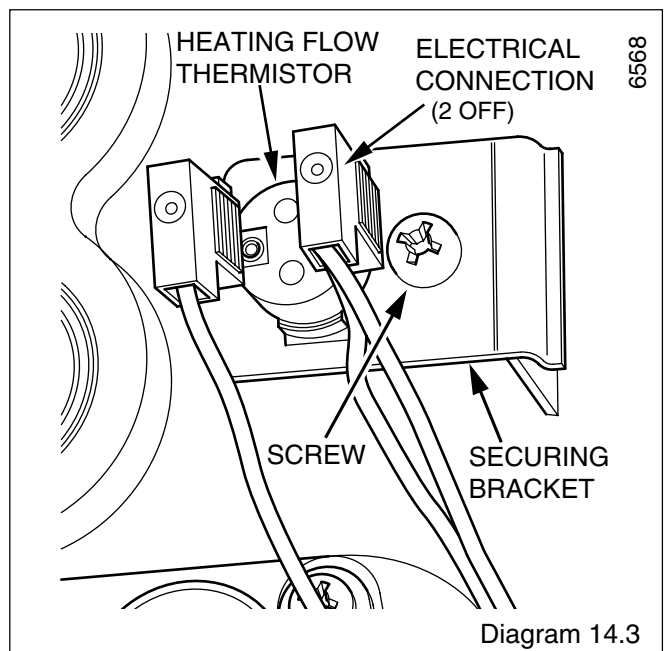
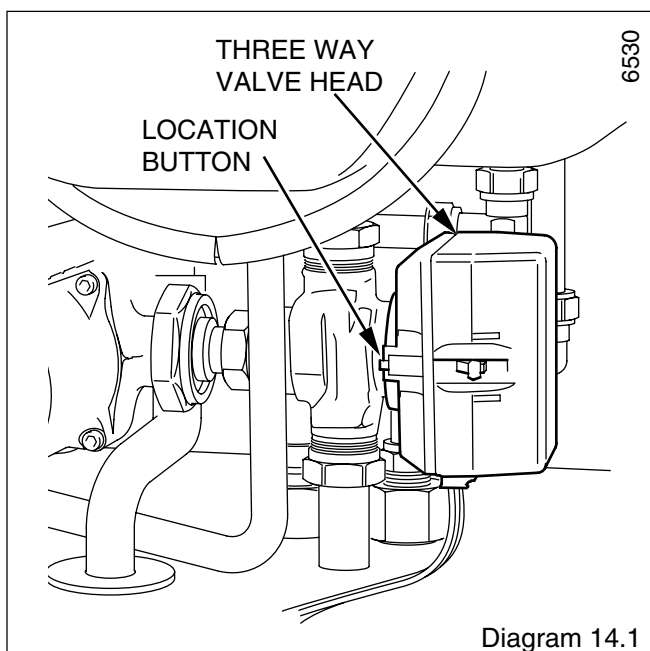
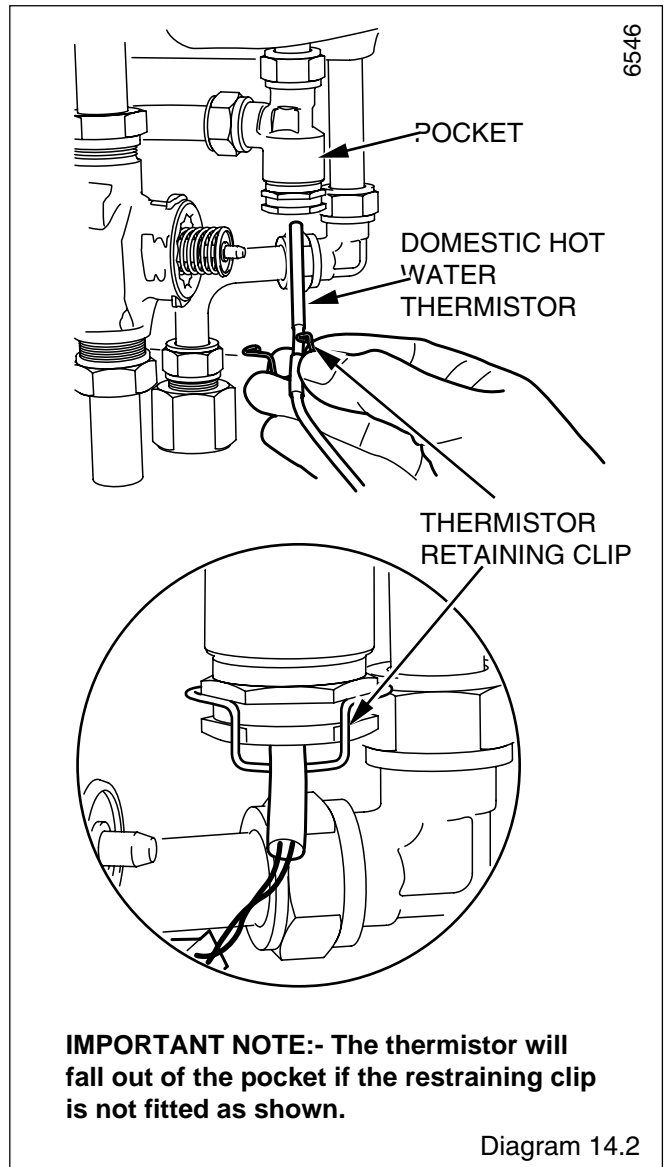

14 Replacement of Parts

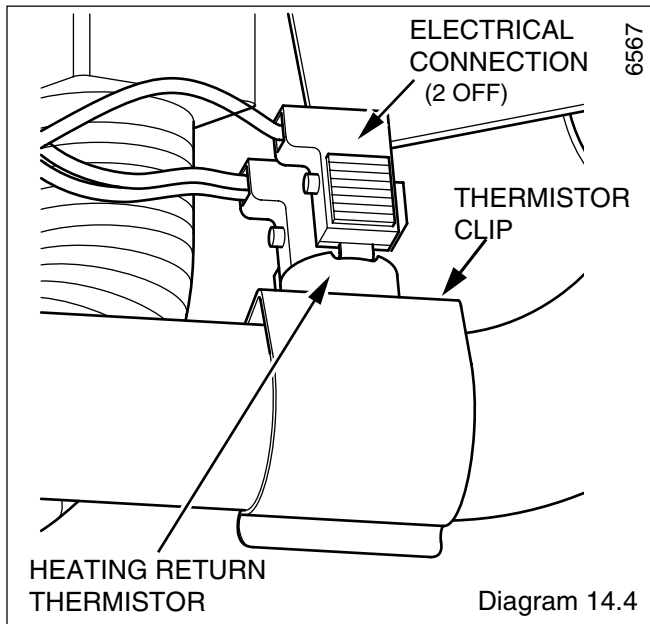

14.16 Pressure Gauge

Refer to section 12.9 and drain the boiler heating circuit.

Undo the union to the return pipe.

Push the pressure gauge out of the controls fascia while depressing the retaining lugs behind the fascia, see diagram 14.5.

When replacing the gauge, ensure that the location pin engages in the slot in the fascia.

Refill, vent and pressurise the boiler.

Check for leaks.

14.17 Low Water Pressure Switch

Refer to section 12.9 and drain the boiler heating circuit.

The Low Water Pressure Switch is located on the boiler flow pipe directly below the heat exchanger.

Remove the automatic control module, see section 14.4.

Remove the condense trap vent pipe by twisting out of the trap body, see diagram 12.2.

Disconnect the electrical connections from the switch.

Using a 27mm spanner, remove the switch from the flow pipe, see diagram 14.6.

Fit the new Low Water Pressure Switch using suitable sealant on the threads.

Refill, vent and pressurise the boiler.

Check for leaks.

14.18 Expansion Vessel

Refer to section 12.9 and drain the boiler heating circuit

Undo the coupling at the base of the vessel.

While holding the vessel undo the securing bolt on the top panel of the boiler. Remove the expansion vessel from the boiler taking care not to lose the securing bolt spacer from the top of the unit.

Fit the replacement unit ensuring that the securing bolt spacer is in position and the securing bolt passes through it.

Refill, vent and pressurise the boiler.

Check for leaks.

14.19 Thermostatic Mixer Valve

Refer to section 12.10 and drain the boiler hot water circuit.

From below the boiler base plate, remove the gas pipe and remove both cold and hot water pipes from the thermostatic mixer valve.

From above the boiler base plate remove the three way valve head. See section 14.5.

Undo both hot and cold water connections to the cylinder.

While holding the thermostatic mixer valve undo the two hexagonal bulkhead connectors, see diagram 14.7.

Fit new valve.

Open the cold water inlet valve.

Check for leaks.

14.20 Hot Water Cylinder

To remove the hot water cylinder it is necessary to drain down the boiler heating and hot water circuits.

Refer to section 12.9 and drain the boiler heating circuit.

Refer to section 12.10 and drain the boiler hot water circuit.

The right hand casing panel should be removed as described in section 12.8.

Remove the expansion vessel as described in section 14.18.

Remove the three way valve as described in section 14.6.

Remove the domestic hot water thermistor as described in section 14.7.

From above the boiler remove the cylinder automatic air vent, see diagram 11.1.

Remove the cylinder securing collar, see diagram 11.1.

Remove the automatic air vent non- return valve from the top of the boiler and temporarily replace the cylinder securing collar.

Undo the thermostatic mixer valve connections to the cylinder.

Remove the thermostatic mixer valve, see section 14.19.

Undo the cylinder flow pipe connection from the bottom left hand side of the cylinder.

While holding the cylinder in place, remove the cylinder securing collar on top of the boiler.

Lean the cylinder forwards and lift upwards, disengaging the location studs at the rear and the cylinder flow pipe connection.

Fit the replacement cylinder ensuring its fitting on the location studs at the rear of the appliance.

When refitting the automatic air vent non - return valve, a suitable thread sealant must be used.

Open the isolating valves of both heating and hot water circuits, refill, vent and pressurise the heating circuit.

Check for leaks.

14.21 Heat Exchanger

Refer to section 12.9 and drain the boiler heating circuit.

Refer to Section 12.10 and drain the boiler hot water circuit.

14 Replacement of Parts

The right hand casing panels should be removed as described in section 12.8.

Remove the gas valve as described in section 14.11.

Remove the fan and burner as described in section 12.3.

Remove the central heating flow thermistor as described in section 14.8.

Remove the ignition electrode as described in section 12.4.

Remove the pump as described in section 14.14.

Remove the hot water cylinder as described in section 14.20.

Remove the automatic control module as described in section 14.4.

Remove the air pressure switch as described in section 14.22.

Remove the wire clip on the internal flue adaptor pipe and pull the adaptor pipe down into the flue outlet pipe, see diagram 7.5.

Pull the flue outlet pipe out of the heat exchanger.

Remove the automatic air vent pipe from the top right hand side of the heat exchanger.

Pull the black condense pipe and vent pipe out of the top of the condense trap body.

Unscrew the heat exchanger condense pipe from the base of the heat exchanger.

Undo the heat exchanger flow pipe connection from the bottom left hand side of the boiler.

Undo and remove the return pipe locking plate from the rear panel below the heat exchanger and pull the return pipe down and out of the casting.

Pry open the heat exchanger retaining clips on the back panel of the appliance and remove the heat exchanger.

After refitting the heat exchanger, fill, vent and pressurise the boiler and check for leaks.

14.22 Air Pressure switch

Remove the sensing tube from the air pressure switch. Disconnect the wires. Unclip the air pressure switch from its plastic retaining clip. Fit the new air pressure switch with the sensing pipe connections downwards, see diagram 14.8.

14.23 Condense trap and siphon

Unscrew the drain cap on the trap and drain off the condensate. Disconnect the overflow pipework from the outlet of the siphon. From underneath the baseplate, unscrew the two condense drain trap securing screws. Pull the condense drain trap away from the bottom of the appliance and disconnect the heat exchanger condense pipe, see diagram 9.1.

Check the condense drain trap gasket and if necessary replace prior to refitting the assembly.

Insert the heat exchanger condense pipe into the trap and siphon assembly prior to fixing to the boiler base.

Refill the condense trap as recommended in section 9.4.

14.24 Display PCB

Unscrew the two securing screws, one on the top front edge of the base panel and the second on the bottom edge of the base panel. Carefully remove the ribbon wire plug from the display PCB. Unclip the PCB from its four retaining pillars on the PCB cover.

When refitting the PCB and cover to the appliance base panel be careful not to trap the ribbon wire behind the cover. The ribbon wire should exit from the right hand side of the cover.

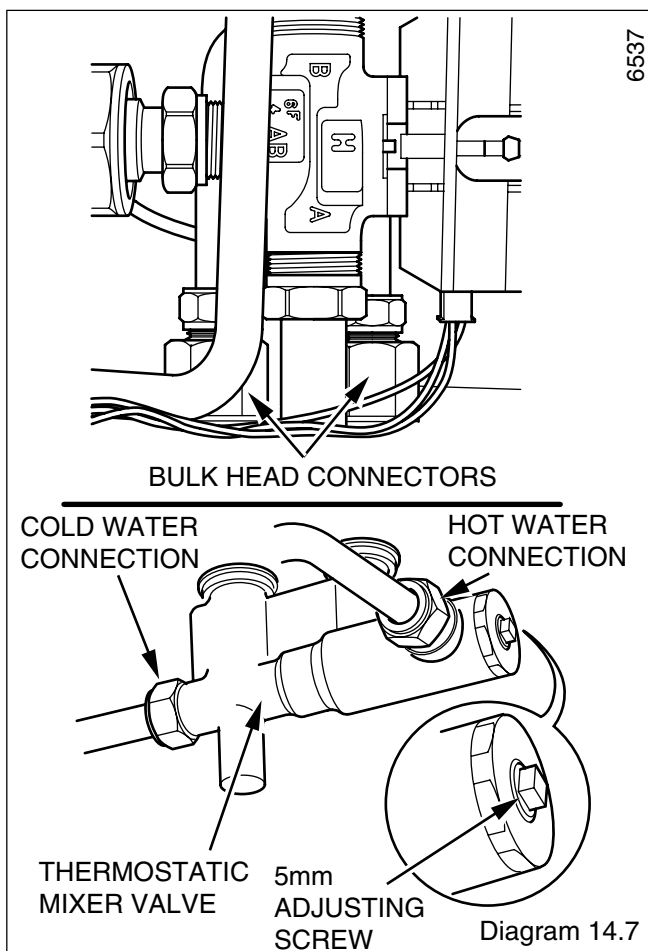
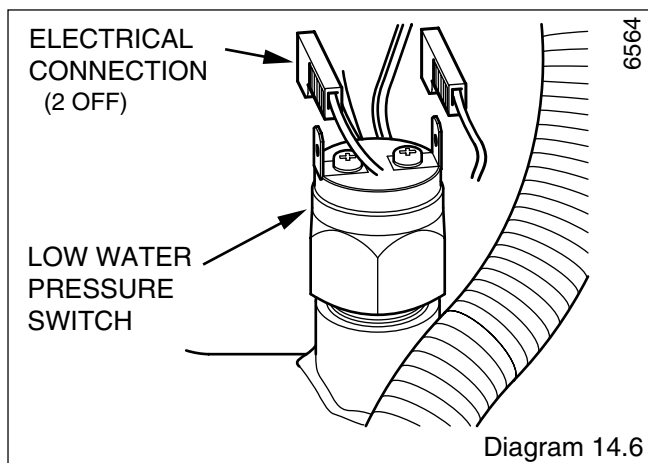
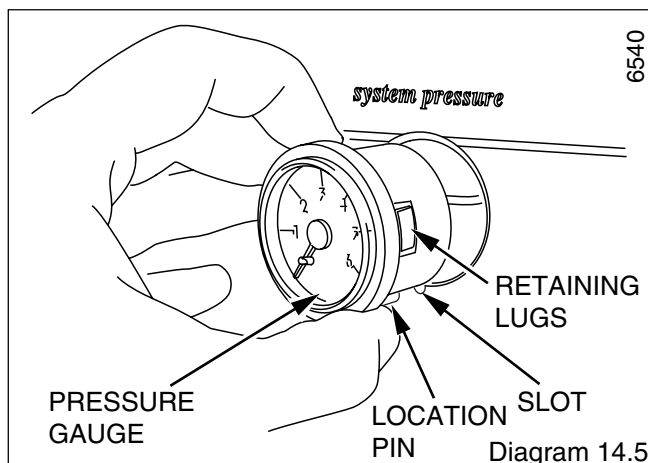

14 Replacement of Parts

14.25 Control Door

Open the control door and pull the brass lugs out of their locations in the fascia, see diagram 11.3.

14.26 Mini Expansion Vessel

If the mini expansion vessel option is fitted it can be replaced by the following method.

Refer to section 12.10 and drain the boiler hot water circuit.

Remove the right hand casing panel as described in section 12.8.

Remove the mini expansion vessel.

Fit new vessel using a suitable thread sealant, see diagram 6.3.

14.27 Spare Part List

Key No.	Part No.	Description	GC Part No.
1	801056	Gas control valve (80)	E24293
1a	801145	Gas control valve (100)	E24434
2	801064	Automatic control module (80)	E24300
2a	801147	Automatic control module (100)	E24436
3	801029	Ignition lead (80)	E24243
3a	801140	Ignition lead (100)	E24418
4	801112	Electrode	E24371
5	801049	Pump	E24288
6	801052	Three way valve head	E24291
7	432875	Mini expansion vessel	360113
8	801034	Heating flow thermistor /Heating return thermistor	E24250
9	208214	Water inlet filter	281359
10	801120	Domestic hot water thermistor	E24381
11	801074	Air pressure switch	E24309
12	801039	Burner (80)	E24257
12a	801142	Burner (100)	E24426
13	801087	Injector (80)	E24336
13a	801154	Injector (100)	E24449
14	801040	Fan (80)	E24259
14a	801040	Fan (100)	E24259

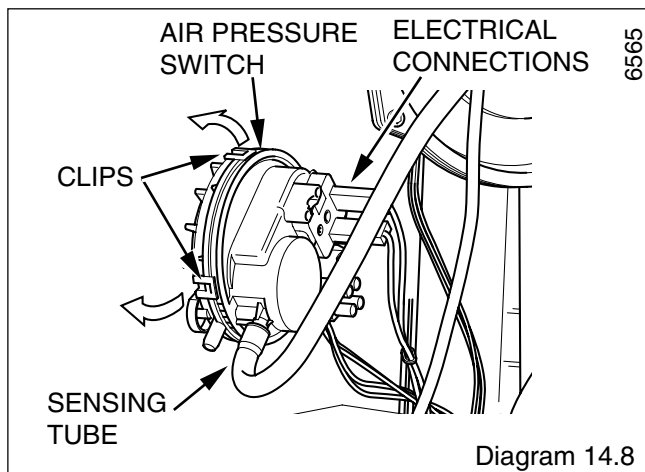
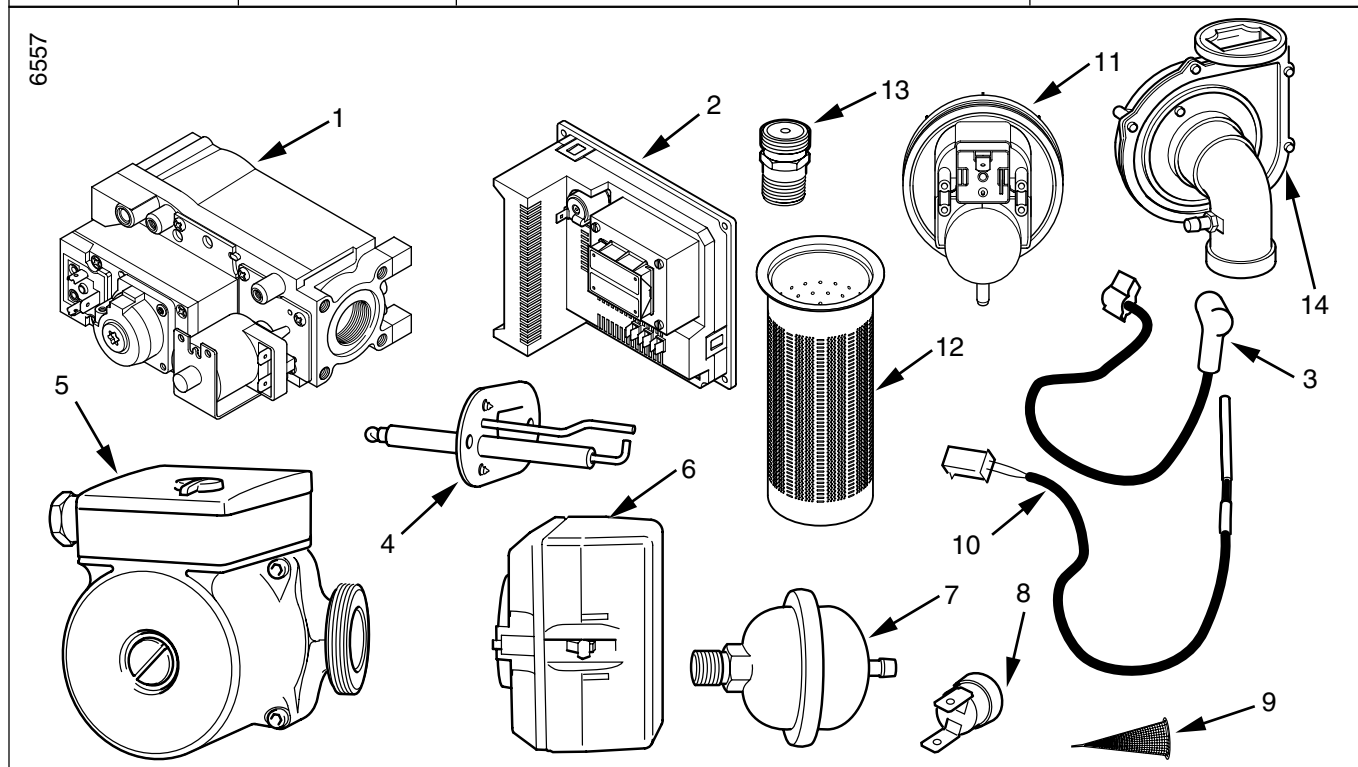

Diagram 14.8



Because of our constant endeavour for improvement, details may vary slightly from those shown in these instructions.