

PulsaCoil BP

Hot water cylinder utilising off-peak electric with an optional solar version

Design, Installation & Servicing Instructions



Models covered in this manual

PulsaCoil PCBP 120
PulsaCoil PCBP 150
PulsaCoil PCBP 180
PulsaCoil PCBP 220

ISSUE 3: 02-11

Section	Page
DESIGN	
Introduction	3
Technical Data	5
System Details	9
INSTALLATION	
Site Requirements	12
Installation	13
Commissioning	16
SERVICING	
Annual Service	17
Changing Components	17
Short Parts List	18
APPENDIX	
Appendix A	19
Appendix B	20
Appendix C	21
BENCHMARK	
Commissioning Checklist	22
Service Record	23
Notes	24
Terms & Conditions	26



Benchmark places responsibilities on both manufacturers and installers. The purpose is to ensure that customers are provided with the correct equipment for their needs, that it is installed, commissioned and serviced in accordance with the manufacturers instructions by competent persons and that it meets the requirements of the appropriate Building Regulations. The Benchmark Checklist can be used to demonstrate compliance with Building Regulations and should be provided to the customer for future reference.

Installers are required to carry out installation, commissioning and servicing work in accordance with the Benchmark Code of Practice which is available from the Heating and Hot Water Industry Council who manage and promote the Scheme. Visit www.centralheating.co.uk for more information.

The Gledhill PulsaCoil range is a WBS listed product and complies with the HWA Specification for hot water only thermal storage products. The principle was developed in conjunction with British Gas. This product is manufactured under an ISO 9001:2008 Quality System audited by BSI.

Gledhill's first priority is to give a high quality service to our customers.

Quality is built into every Gledhill product and we hope you get satisfactory service from Gledhill.

If not please let us know.

DESIGN

Any water distribution system/installation must comply with the relevant recommendations of the current version of the Regulations and British Standards listed below:-

Building Regulations
Requirements for Electrical Installations
Water Regulations
Manual Handling Operations Regulations

British Standards

BS6700 and BS7671.

The Building Regulations (England & Wales) require that the installation of a heating appliance be notified to the relevant Local Authority Building Control Department. From 1st April 2005 this can be achieved via a Competent Person Self Certification Scheme as an option to notifying the Local Authority directly. Similar arrangements will follow for Scotland and will apply in Northern Ireland from 1st January 06.

A suitably competent trades person must install the PulsaCoil and carry out any subsequent maintenance/repairs. In fact the appliance front cover is secured by 2 screws and this should only be removed by a competent trades person. The manufacturer's notes must not be taken as overriding statutory obligations.

The PulsaCoil BP is not covered by section G3 of the current Building Regulations and is therefore only notifiable to Building Control as part of the domestic water installations.

The PulsaCoil BP is not intended for use by persons (including children) with reduced physical, sensory or mental capabilities, or lack of experience or knowledge, unless they have been given supervision or instruction concerning use of the appliance by a person responsible for their safety.

Children should be supervised to ensure that they do not play with the appliance.

The information in this manual is provided to assist generally in the selection of equipment. The responsibility for the selection and specification of the equipment must however remain that of the customer and any Designers or Consultants concerned with the design and installation.

Please Note: We do not therefore accept any responsibility for matters of design, selection or specification or for the effectiveness of an installation containing one of our products unless we have been specifically requested to do so.

All goods are sold subject to our Conditions of Sale, which are set out at the rear of this manual.

In the interest of continuously improving the PulsaCoil range, Gledhill Building Products Ltd reserve the right to modify the product without notice, and in these circumstances this document, which is accurate at the time of printing, should be disregarded. It will however be updated as soon as possible after the change has occurred.



DESIGN

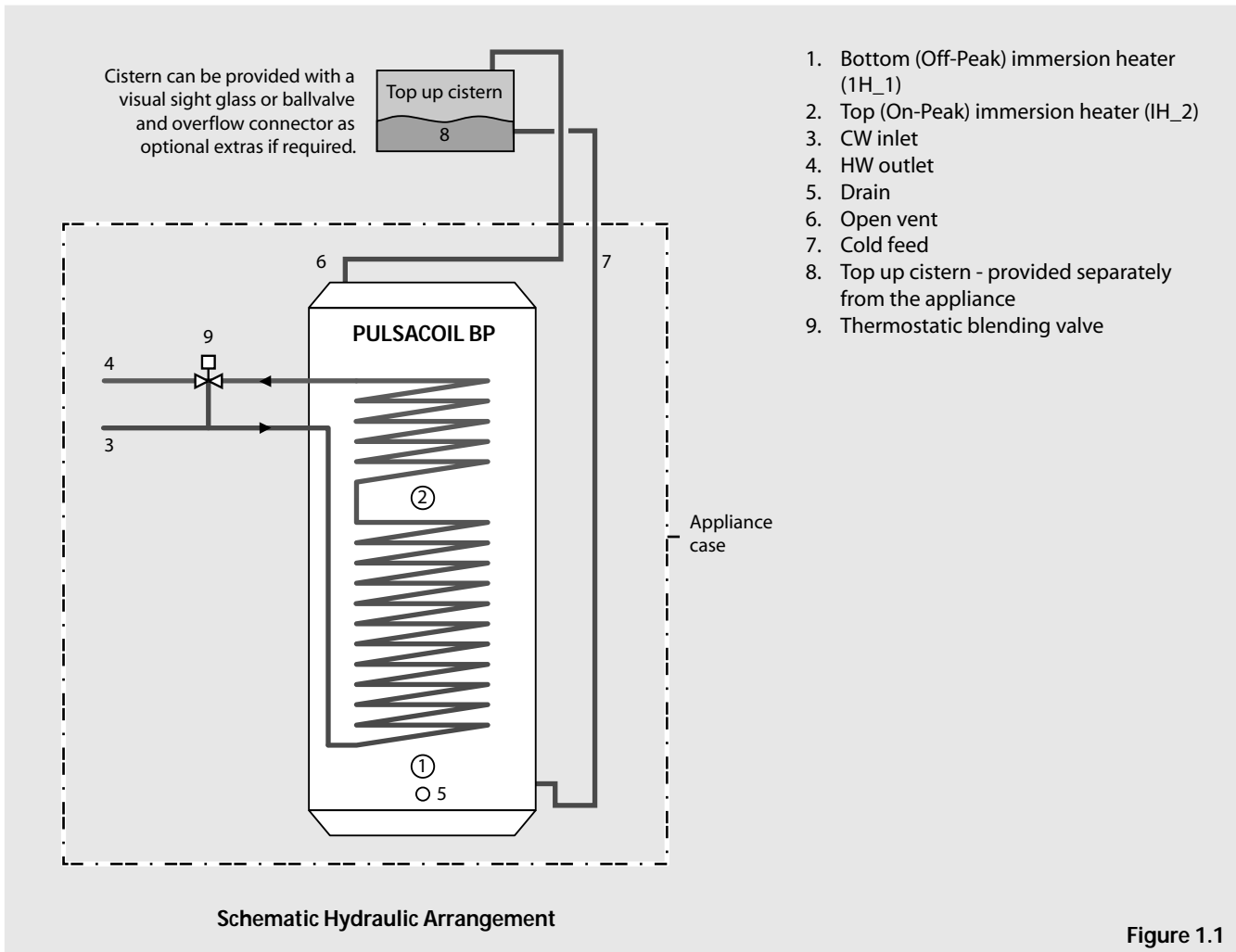

Figure 1.1

The Pulsacoil BP shown schematically above is a very highly insulated appliance. As such, the products will allow a pass to be achieved in SAP2005 even in small apartment situations, which is to provide an improved method of supplying mains pressure hot water when using a suitable off peak electric supply/tariff.

The heat losses from thermal stores should not be directly compared with heat losses from unvented or vented cylinders because they are treated differently in SAP. The SAP calculator takes account of the type of store and various correction factors are included to reflect the different ways that the hot water and heating operates.

The main feature of the concept is that hot water can be supplied directly from the mains at conventional flow rates without the need for temperature and pressure relief safety valves or expansion vessels. This is achieved by passing the mains water through heat exchangers inside the thermal store. The outlet temperature of the domestic hot water is maintained by a thermostatic blending valve.

The Building Regulations L1A: New dwellings/L1B: Existing dwellings and the requirements set out in the Domestic Heating Compliance Guide specify that "where the mains water hardness exceeds 200ppm provision should be made to treat the feed water to water heaters and the hot water circuit of combination boilers to reduce the rate of accumulation of lime scale".

To comply with this requirement the hardness of the mains water should be checked by the installer and if necessary the optional factory fitted in-line scale inhibitor should be specified at the time of order for hardness levels between 200 and 300 ppm (mg/l).

Where the water is very hard ie 300ppm (mg/l) and above the optional polyphosphate type, scale inhibitor should be specified at the time of order. However, this will need to be fitted by the installer at a suitable point in the cold water supply to the appliance.

Because this product does not require a safety discharge from a temperature and pressure relief valve, any installations will be easy to incorporate into the building and will not suffer from the problems associated with using PVCu soil stacks to take the discharge from unvented cylinders.

Table 1.1

Technical Specification					
Description		PCBP 120	PCBP 150	PCBP 180	PCBP 220
Appliance height	mm	1131	1332	1533	1734
Appliance width	mm	560	560	560	560
Appliance depth	mm	605	605	605	605
Appliance weight (empty)	kg	54	63	69	78
Approx weight (full)	kg	172	205	234	268
Total volume (nominal)	litres	118	142	165	190
Volume heated (on peak)	litres	60	60	70	80
Heat loss ¹	kWh/24hr	1.12	1.31	1.50	1.60
Hot water flow rate ²		up to 18 litres/minute		up to 22 litres/minute	

Table 1.2

Model Selection					
Bedroom		1	1-2	2-3	2-3
Bathroom		1 or	1 or	1	1
En-suite shower room		1	1	1	2
Model selection data (7 hour off peak)		PCBP 150	PCBP 150	PCBP 180	PCBP 220
Model selection data (10 hour off peak)		PCBP 120	PCBP 150	PCBP 150	PCBP 180

Notes:-

1. The heat losses from thermal stores should not be directly compared with heat losses from unvented or vented cylinders because they are treated differently in SAP. The SAP calculator takes account of the type of store and various correction factors are included to reflect the different ways that the hot water and heating operates.
2. The flow rates are based on a 35°C temperature rise and assume that recommended pressures and adequate flow are available at the appliance. The flow rate will be reduced if the available water pressure is below that recommended.
3. The domestic hot water outlet temperature is automatically regulated to approximately 52°C at the bath flow rate of 18 litres/min recommended by BS 6700. The temperature is user adjustable.

DESIGN



Figure 1.2

Standard Equipment

The standard configuration of the Pulsacoil BP is shown opposite.

1. Drain - 1/2" BSP
2. Cold water inlet (22mm)
3. Hot water outlet (22mm)
4. Bottom (off-peak) immersion heater (3kW)
5. Top (on-peak) immersion heater (3kW)
6. Scale inhibitor PCB - (factory fitted optional extra)
7. Hot water thermostatic blending valve
8. Cold feed/expansion pipe (15mm)
9. Open vent pipe (22mm)
10. Manual fill sight glass for top up cistern (not shown)

Note : Both immersion heaters are low watts density type with incoloy 825 sheaths and are specially manufactured to suit Thermal Stores. It is recommended that any replacements should be obtained from Gledhill Building Products.

Optional Extra Equipment

- In line scale inhibitor for mains water services with hardness levels between 200 and 300ppm (mg/l) fitted but ready for wiring by the installer to the suitable 230V ac supply.
- Polyphosphate scale inhibitor for fitting on site by the installer.
- Ballvalve/overflow connector for top up cistern.

DESIGN

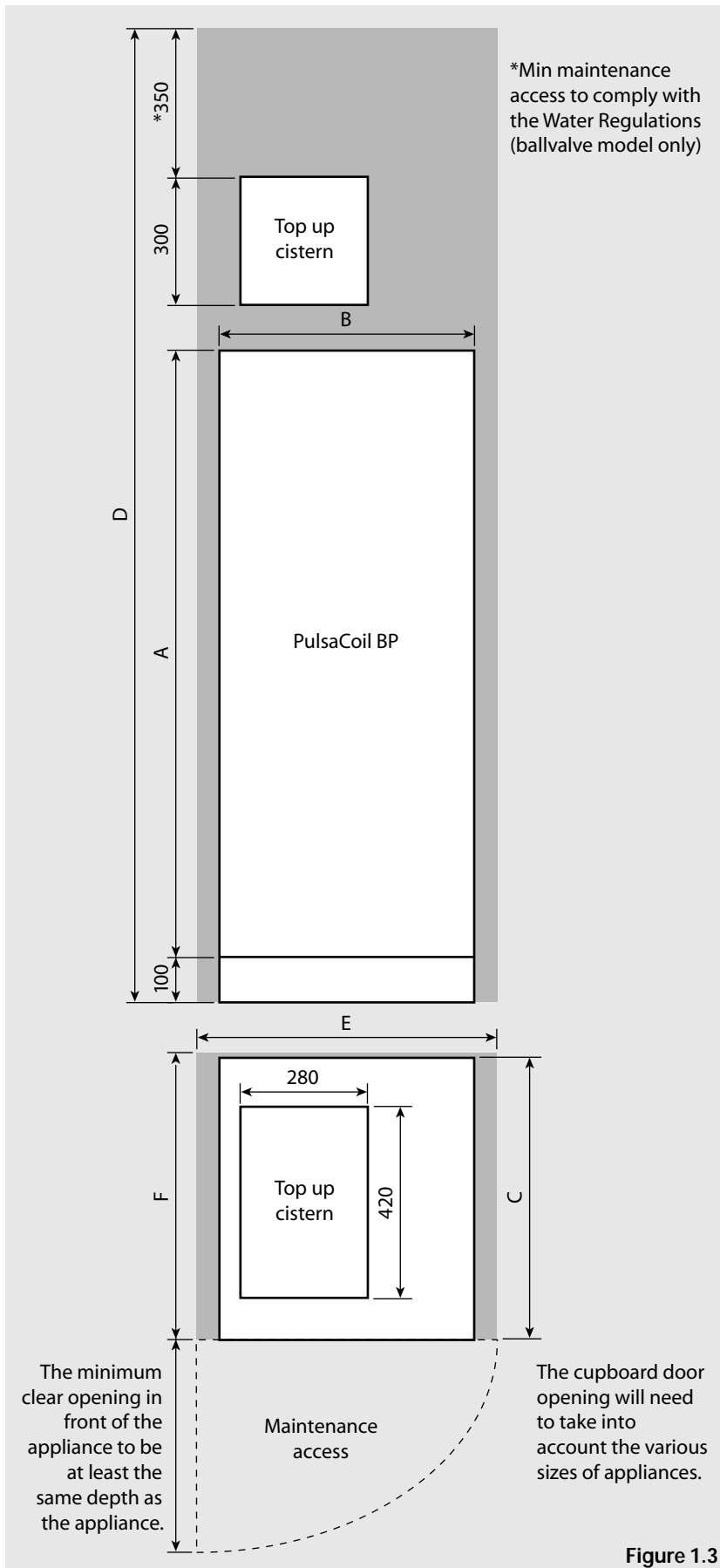

Appliance Dimensions			
Model	Height (A)	Width (B)	Depth (C)
PCBP 120	1131	560	605
PCBP 150	1332	560	605
PCBP 180	1533	560	605
PCBP 220	1734	560	605

Note: The Appliance dimensions above do not allow for the 100mm high installation base.

The following table of minimum cupboard dimensions only allow the minimum space required for the appliance (including the top up cistern). Any extra space required for shelving etc in the case of airing cupboards etc must be added.

Minimum Cupboard Dimensions			
Model	Height (D)	Width (E)	Depth (F)
PCBP 120	1881	600	620
PCBP 150	2082	600	620
PCBP 180	2283	600	620
PCBP 220	2484	600	620

Note: The above dimensions are based on the Appliance and the Top up cistern (fitted with a ballvalve) being in the same cupboard. **If the manual fill model is chosen, the heights shown above can be reduced by 125mm.**

If pipework needs to rise vertically adjacent to the appliance the width/depth will need increasing to accommodate this.

Figure 1.3

DESIGN

PLAN OF APPLIANCE CONNECTIONS

The PulsaCoil BP units are supplied on an installation base to allow the pipe runs to connect to the appliance from any direction. It is easier if all pipes protrude vertically in the cut out area shown. Compression or push fit connections can be used. All pipe positions are approximate and subject to a tolerance of +/- 10mm in any direction. Space will also be required for a 15mm cold water supply and a 22mm warning / overflow pipe (if the optional extra ball valve and overflow connector have been specified. If a warning/overflow pipe is NOT provided the F&E Cistern should be filled from a temporary hose connection incorporating a double check valve. This can be from a temporary hose connection supplied from a cold water tap or a permanent cold branch provided adjacent to the Top up Cistern. The temporary connection must be removed once the appliance is filled.

Note: All dimensions are shown in mm and are to the centre line of pipework.

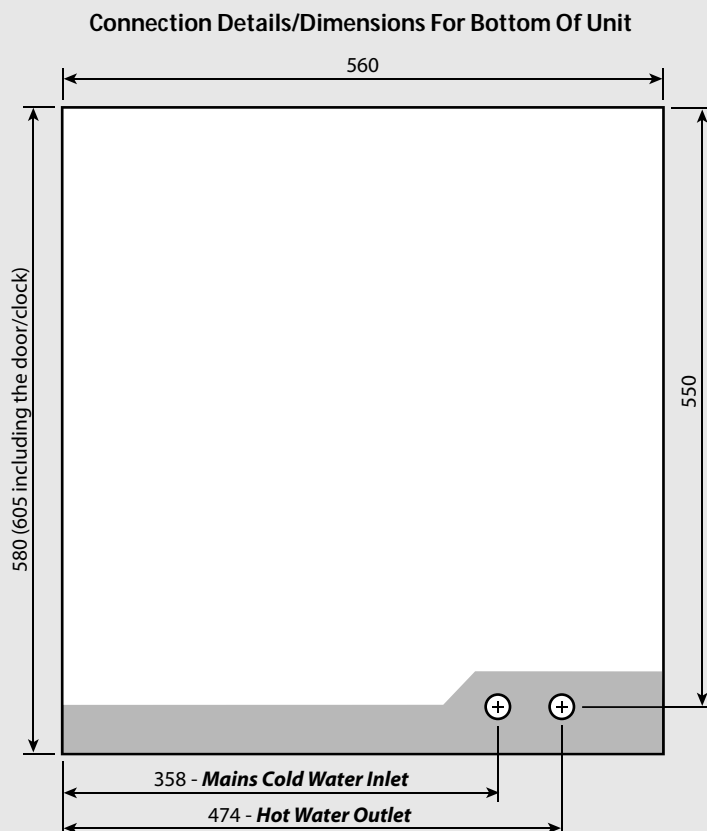
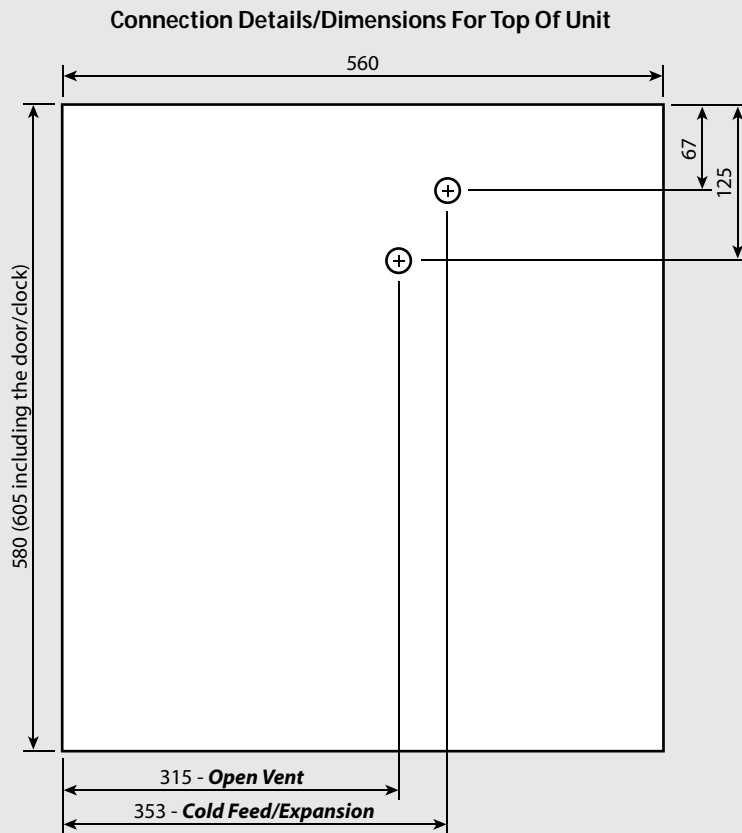

Figure 1.4

Hot and Cold Water System

General

A schematic layout of the hot and cold water services in a typical small dwelling is shown below. Pulsacoil BP will operate at mains pressures as low as 1.5 bar and as high as 5 bar although the recommended range is 2-3 bar dynamic at the appliance. It is also important to check that all other equipment and components in the hot and cold water system are capable of accepting the mains pressure available to the property. If the mains pressure can rise above 5 bar or the maximum working pressure of any item of equipment or component to be fitted in the system, a pressure limiting (reducing) valve set to 3 bar will be required.

If you encounter a situation where the water pressure is adequate but flow rates are poor please contact our technical helpline for details of an effective solution.

No check valve or similar device should be fitted on the cold water supply branch to the Pulsacoil BP.

The Building Regulations L1A: New dwellings/L1B: Existing dwellings and the requirements set out in the Domestic Heating Compliance Guide specify that "where the mains water hardness exceeds 200ppm provision should be made to treat the feed water to water heaters and the hot water circuit of combination boilers to reduce the rate of accumulation of lime scale"

To comply with this requirement the hardness of the mains water should be checked by the installer and if necessary the optional factory fitted in-line scale inhibitor should be specified at the time of order for hardness levels between 200 and 300 ppm (mg/l).

Where the water is very hard ie 300ppm (mg/l) and above the optional polyphosphate type, inhibitor should be specified at the time of order. However, this will need to be fitted by the installer at a suitable point in the cold water supply to the appliance.

The hot water flow rate from the Pulsacoil BP is directly related to the adequacy of the cold water supply to the dwelling. This must be capable of providing for those services, which could be required to be supplied simultaneously, and this maximum demand should be calculated using procedures defined in BS 6700.

If a water meter is fitted in the service pipe, it should have a nominal rating to match the maximum hot and cold water peak demands calculated in accordance with BS 6700. This could be up to 60ltr/min in some properties.

Note: The diagram below shows the Top up cistern with ballvalve and warning/overflow pipe. The ballvalve/overflow connector can be supplied as an optional extra if required. However, the standard preferred arrangement is for the cistern to be manually filled from a temporary hose connection fitted with a double check valve.

The cistern must not be fitted more than 6 metres above the Pulsacoil BP appliance itself.

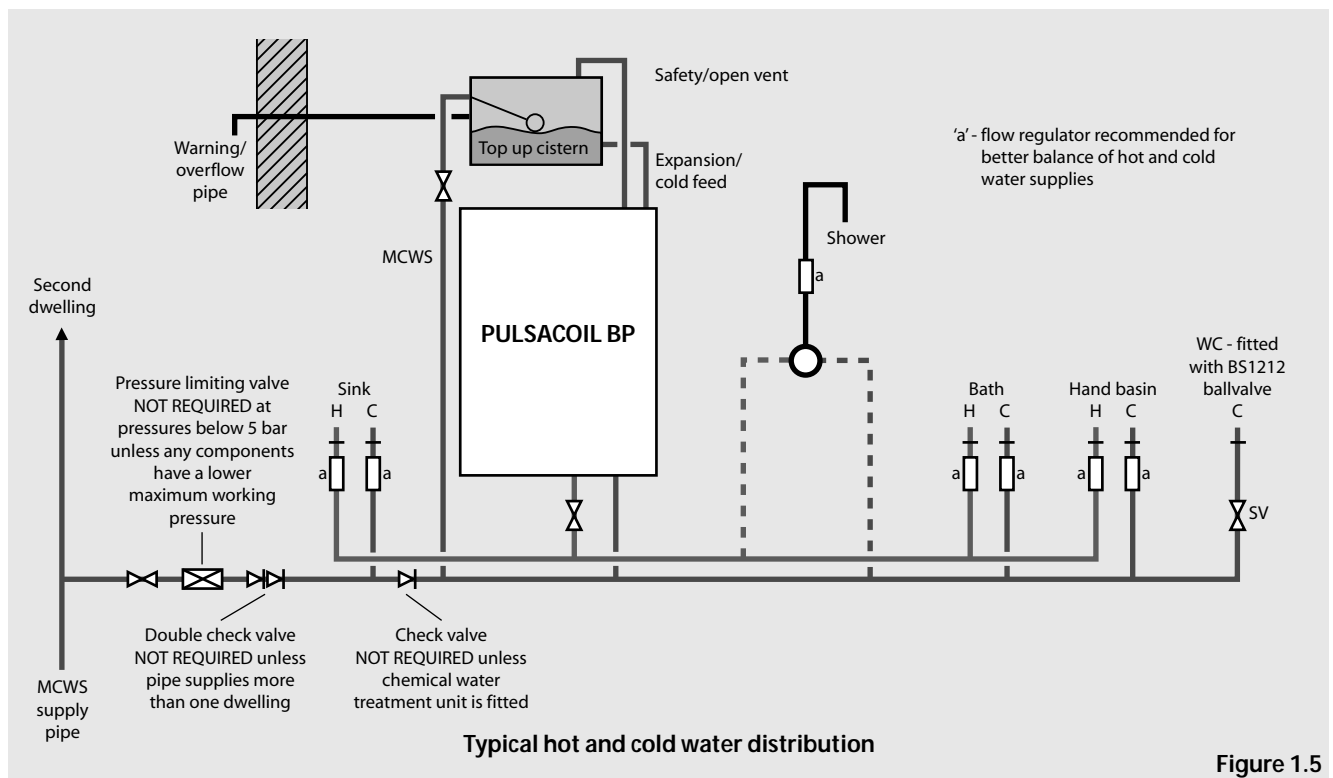

Figure 1.5

DESIGN

Hot and Cold water System

Pipe Sizing / Materials

To achieve even distribution of the available supply of hot and cold water, it is important in any mains pressure system, that the piping in a dwelling should be sized in accordance with BS 6700. This is particularly important in a large property with more than one bathroom.

However, the following rule of thumb guide lines should be adequate for most smaller property types as long as water pressures are within the recommended range.

1. A 15mm copper or equivalent external service may be sufficient for a small 1 bathroom dwelling (depending upon the flow rate available), but the minimum recommended size for new dwellings is 22mm (25mm MDPE).
2. The internal cold feed from the main incoming stop tap to the PulsaCoil should be run in 22mm pipe. The cold main and hot draw-off should also be run in 22mm as far as the branch to the bath tap.
3. The final branches to the hand basins and sinks should be in 10mm and to the baths and showers in 15mm. (1 metre minimum)
4. **We would recommend that best results for a balanced system are achieved by fitting appropriate flow regulators to each hot and cold outlet. This is particularly relevant where the water pressures are above the recommended water pressure range. Details of suitable flow regulators are provided in Appendix.**

All the recommendations with regard to pipework systems in this manual are generally based on the use of BS/EN Standard copper pipework and fittings.

However, we are happy that plastic pipework systems can be used in place of copper internally as long as the chosen system is recommended for use on domestic hot and cold water systems by the manufacturer and is installed fully in accordance with their recommendations.

It is also essential that if an alternative pipework material/system is chosen the manufacturer confirms that the design criteria of the new system is at least equivalent to the use of BS/EN Standard copper pipework and fittings.

Taps/Shower Fittings

Aerated taps are recommended to prevent splashing.

Any type of shower mixing valve can be used as long as both the hot and cold supplies are mains fed. However all mains pressure systems are subject to dynamic changes particularly when other hot and cold taps/showers are opened and closed, which will cause changes in the water temperature at mixed water outlets such as showers. For this reason and because these are now no more expensive than a manual shower we strongly recommend the use of thermostatic showers with this appliance.

The shower head provided must also be suitable for mains pressure supplies.

However, if it is proposed to use a 'whole body' or similar shower with a number of high flow/pressure outlets please discuss with the Gledhill technical department.

The hot water supply to a shower-mixing valve should be fed wherever practical directly from the PulsaCoil BP or be the first draw-off point on the hot circuit. The cold supply to a shower-mixing valve should wherever practical be fed directly from the rising mains via an independent branch. The shower must incorporate or be fitted with the necessary check valves to provide back-syphonage protection in accordance with the Water Regulations.

The supply of hot and cold mains water directly to a bidet is permitted provided that it is of the over-rim flushing type and that a type 'A' air gap is incorporated.

Hot and Cold Water System

If the length of the hot water draw off pipework is excessive and the delivery time will be more than 60 seconds before hot water is available at the tap, you may wish to consider using trace heating to the hot water pipework such as the Raychem HWAT system. Please consult Gledhill technical department for further details.

Also a conventional pumped secondary circulation system can be used with this appliance.

It is important that the cold water pipework is adequately separated/protected from any heating/hot water pipework to ensure that the water remains cold and of drinking water quality.

DESIGN

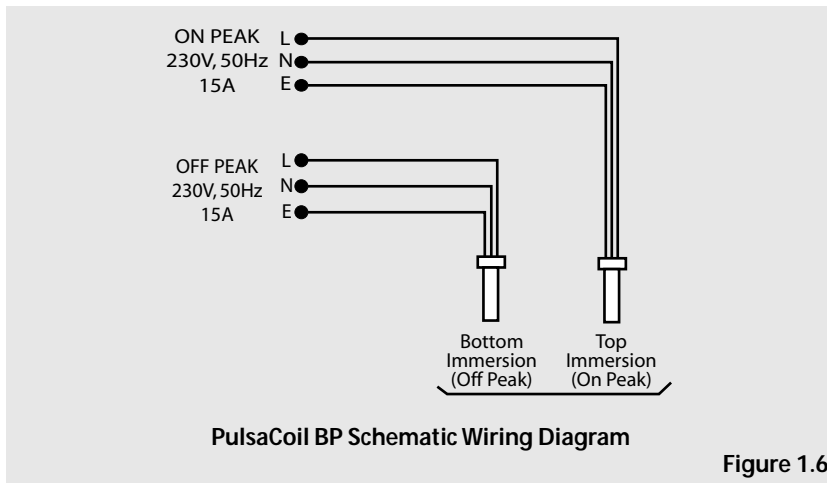

Figure 1.6

Electrical Installation

The Schematic arrangement of the wiring within the PulsaCoil BP is shown opposite.

The whole of the electrical installation shall be designed and installed by a competent person fully in accordance with the latest edition of the Requirements for Electrical installations BS 7671.

The PulsaCoil BP appliance is provided with two side entry 3kW immersion heaters and has been designed to generally operate with an off peak supply.

The lower immersion heater heats the whole of the contents and is normally connected to the off peak supply.

The upper immersion heater is positioned at a level on the PulsaCoil BP to heat the top 50 - 80 litres of the store - see Technical Data Table on page 5. This is connected to the unrestricted on peak supply and is switched manually by the householder using the off-peak controller, eg. Horstman Electronic 7 Controller.

The size of the appliance and the need to use the on peak boost facility is reduced if a better off peak tariff can be agreed with the electrical supply company - see Model Selection Guide on page 5.

The typical wiring arrangement is shown in figure 1.7. An economy 7 controller (eg Horstman Electronic 7) is used for a manual boost and automatic off-peak heating of hot water.

If a factory fitted scale inhibitor has been specified, then it should be wired to a permanent supply as shown in figure 1.8.

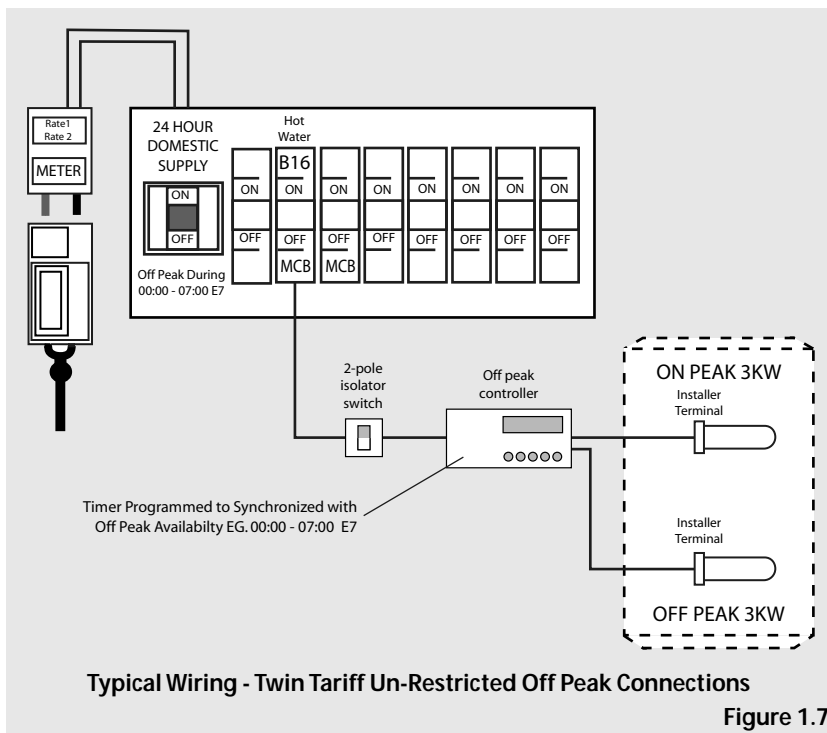

Figure 1.7

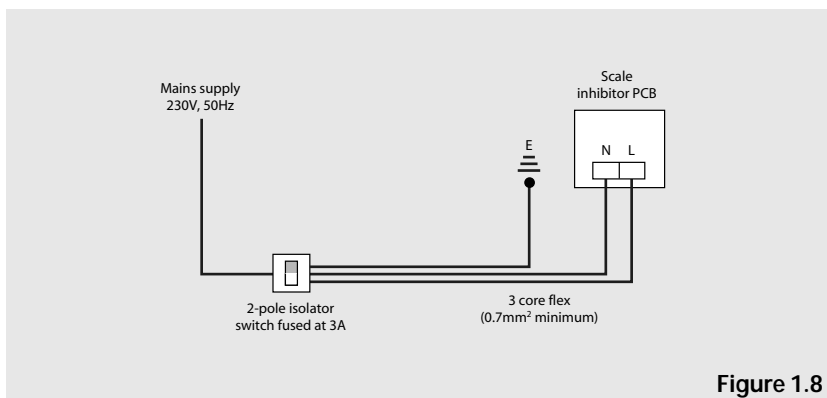

Figure 1.8

INSTALLATION

The appliance is designed to be installed in an airing/cylinder cupboard and the relevant minimum dimensions are provided in the Technical Data section of this manual.

Because of the ease of installation we recommend that the cupboard construction is completed and painted before installation of the appliance. The cupboard door can be fitted after installation.

If the unit needs to be stored prior to installation it should be stored upright in a dry environment and on a level base/floor.

Installation and maintenance access is needed to the front of the appliance and above the top up cistern. See the Technical Data section of this manual for further details.

The minimum dimensions, contained in the Technical Data section, allow for the passage/connection of pipes to the appliance from any direction as long as the appliance is installed on the installation base provided. If the installation base is not used extra space may be needed to allow connection to the pipework and the whole of the base area should be continuously supported on a material which will not easily deteriorate if exposed to moisture.

The floor of the cupboard needs to be level and even and capable of supporting the weight of the appliance when full. Details of the weight when full is provided in the Technical Data section of this manual.

The appliance is designed to operate as quietly as practicable. This will be most noticeable if the cupboards are located adjacent to bedrooms, on bulkheads, or at the mid span of a suspended floor. Some noise may also be experienced from the immersion heaters as the store approaches its design temperature.

Cupboard temperatures will normally be slightly higher than in a conventional system and the design of the cupboard and door will need to take this into account. No ventilation is normally required to the cupboard.

The separate Top up cistern will need to be located on top of the appliance or at high level in the cupboard housing the PalsaCoil BP. The dimensions and clearances are provided in the Technical Data section of this manual. If the top up cistern is sited remotely, the location will need to provide a suitable route for the cold feed expansion pipe as well as the open safety vent pipe. If the ballvalve/overflow connector have been ordered (available as optional extras), the location will also need to provide a suitable route and discharge position for the warning/overflow pipe and the ballvalve supply from the mains cold water system.

Note: The standard appliance is supplied with a cistern without a ballvalve/overflow for filling manually.

An electrical supply must be available which is correctly earthed, polarized and in accordance with the latest edition of the IEE requirements for electrical Installations BS 7671.

The electrical mains supply needs to be 230V/50Hz.

The sizes/types of electrical supplies must be as detailed in System Details section of this manual. A means for disconnection from the supply mains having a contact separation in all poles that provides full disconnection under over voltage category III conditions must be incorporated in the fixed wiring in accordance with the wiring rules. This shall be located within 1m of the appliance and only serve the appliance.

The hot and cold water 'first fix' pipework should be terminated 50mm above the finished floor level in accordance with the dimensions provided in the Technical Data section.

INSTALLATION

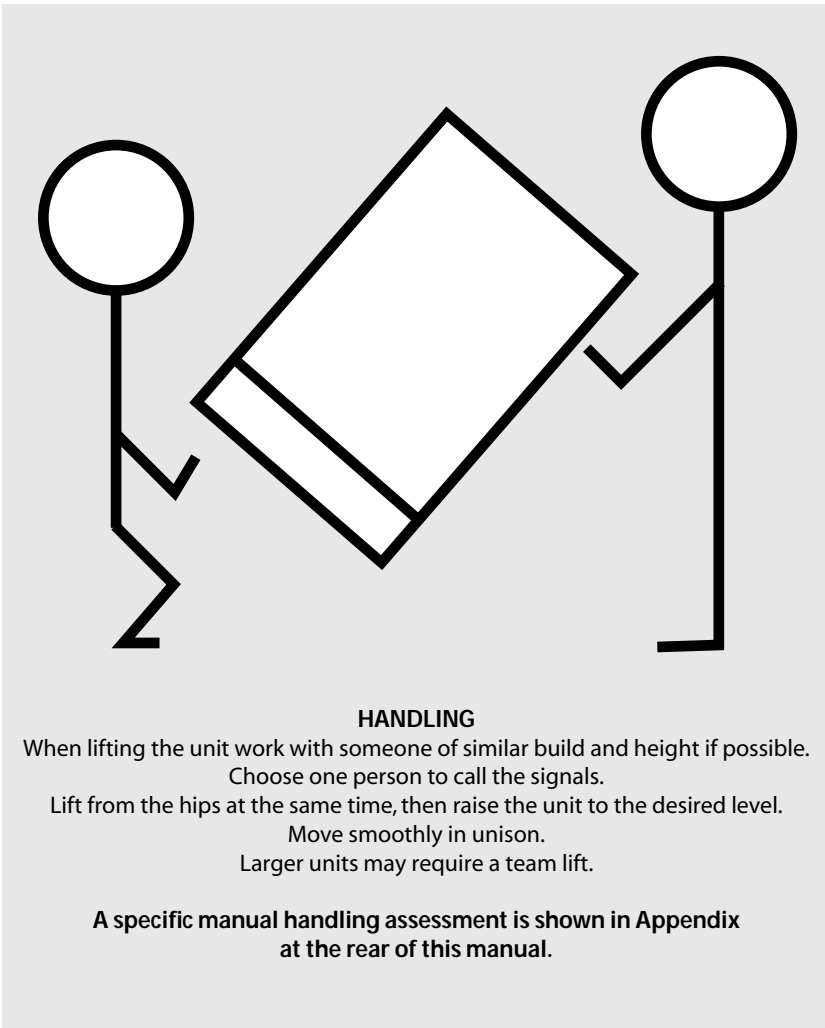

Preparation/placing the appliance in position.

The appliance is supplied shrink wrapped on a timber installation base with the F&E cistern on top of the unit. Carrying handles are also provided in the back of the casing.

The appliance should be handled carefully to avoid damage and the recommended method is shown above.

Note: Although the above guidance is provided any manual handling/lifting operations will need to comply with the requirements of the Manual Handling Operations Regulations issued by the H.S.E. - further details are provided in Appendix C.

The appliance can be moved using a sack truck on the rear face although care should be taken and the route should be even.

In apartment buildings containing a number of storeys we would recommend that the appliances are moved vertically in a mechanical lift.

If it is proposed to use a crane expert advice should be obtained regarding the need for slings, lifting beams etc.

Before installation the site requirements should be checked and confirmed as acceptable.

The plastic cover and protective wrapping should be removed from the appliance and the installation base (provided) placed in position.

The appliance can then be lifted into position in the cupboard on top of the base and the front panel removed by unscrewing the 2 screws and lifting the door up and out, ready for connection of the pipework and electrical supplies.

The feed and expansion cistern support shall be installed ensuring that the base is fully supported, the working head of the appliance is not exceeded and the recommended access is provided for maintenance - see the Technical Data section of this manual for details.

INSTALLATION



Figure 1.9

Pipework connections

The position of the pipework connections is shown opposite. The exact location dimensions are listed in the Technical Data section of this manual.

All the connections are also labelled on the appliance. It is essential that the pipework is connected to the correct connection.

Connections A and B are plain ended copper pipe.
Connection C and D are compression fittings.
Connection E is RC $\frac{1}{2}$ ($\frac{1}{2}$ in BSPT internal)

- A - 22mm Safety open vent
- B - 15mm Cold feed/expansion
- C - 22mm Incoming mains cold water
- D - 22mm Domestic hot water
- E - $\frac{1}{2}$ " Drain tap connection

Note: The safety open vent and cold feed/expansion must be connected to the top up cistern using the pipework assembly provided. Do not alter or connect any pressure-relief device to the vent pipe of this water heater.

All factory made joints should be checked after installation in case they have been loosened during transit.

The fittings for the top up cistern should be installed following the instructions provided and the cistern fitted on its supports/top of the appliance.

INSTALLATION

It is normally envisaged that the top up cistern will be located in the same cupboard as the Pulsacoil BP appliance itself to maintain a dry roof space.

The cold feed/open vent pipework (as supplied) should be used to install the top up cistern directly on top of the appliance.

If it is necessary to locate the cistern in any other location, the cold feed/open vent pipework (as supplied) should be used to connect to the top up cistern and pipework site run by the installer to connect this to the appliance.

Obviously, any pipework in the roof space and the feed and expansion cistern will need to be adequately insulated to protect against frost damage.

Combined feed and open pipe arrangements must not be used.

No valves should be fitted in the safety open vent which must be a minimum of 22mm copper pipe or equivalent throughout its length.

The mains cold water supply to the ballvalve (if provided) shall be provided with a suitable servicing valve.

The overflow/warning pipe (if provided) shall have a continuous fall, be fitted to discharge clear of the building and be sited so that any overflow can be easily observed. It shall also be installed in a size and material suitable for use with heating feed and expansion cisterns in accordance with BS 5449 (e.g 22mm copper) and should not have any other connections to it.

Note: If a warning/overflow pipe is NOT provided the top up cistern should be filled from a temporary hose connection supplied from any cold water tap or from a permanent cold branch provided adjacent to the top up cistern. The temporary hose must be fitted with a double check valve and removed once the appliance is filled.

The store may fill more slowly than the feed tank. It is important to check the water level again in the cistern after commissioning and top up if necessary.

Electrical Connection - Standard Appliance

The Pulsacoil BP immersion heater wiring/connections should be carried out by a competent person to the IEE Requirements for Electrical Installations BS 7671.

All the immersion heater terminals are suitably labelled.

Note: Do not attempt the electrical work unless you are competent to carry it out to the above standards.

Before commencing check that the power source is in accordance with the Site Requirements section of this manual and ensure that it is isolated.

- 1) Run the external wiring from the adjacent isolator through the service slot provided in the base of the appliance to the appropriate immersion heaters.
- 2) You may also run the external wiring from the adjacent isolator through the service slots provided in the base of the appliance to the scale inhibitor PCB terminals as shown in figure 1.8.

Note: The appliance pipework should be bonded to earth to comply with the IEE Requirements for Electrical Installations BS 7671.

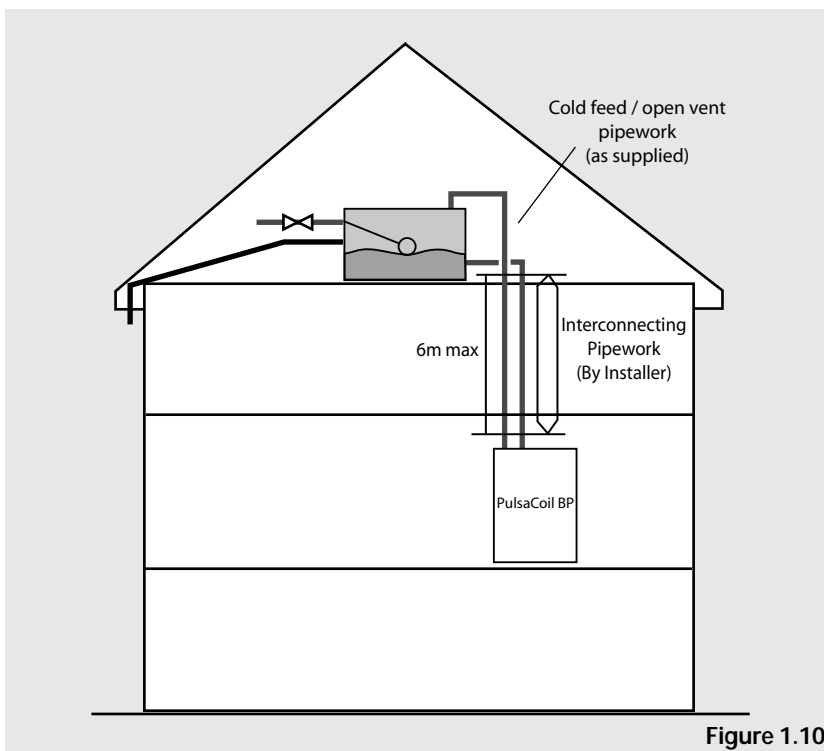

Figure 1.10

INSTALLATION

Open the incoming stop valve and fill the domestic mains cold and hot water systems including the PulsaCoil BP appliance.

Check the water level in the top up cistern and if a ballvalve is fitted adjust if necessary.

Check the whole of the domestic hot and cold distribution systems for leaks. Fully flush and if necessary chlorinate the hot and cold water system in accordance with the recommendations in the Water Regulations and BS 6700.

Please note that the whole of the domestic hot and cold water systems including the appliance must be adequately flushed after chlorination. Failure to do this can cause damage to the exchangers/immersion heaters etc. If there are any doubts regarding this or the quality of the water being used to fill the PulsaCoil BP appliance an inhibitor such as Fernox MBI or Sentinel X100 should be added to the appliance when filling in line with the manufacturers instruction for these products.

It is **most important** to check that the top up tank is filled up to the water level shown on the label, if it is a manual fill model. If the optional level gauge has been provided, the level will be shown by the red float.

If a ballvalve is provided, turn down the servicing valve once the system is finally filled to the point where the warning/overflow pipe will cope with the discharge arising from a ballvalve failure.

If an overflow is not provided ensure the temporary filling hose is isolated and removed from its connection to the cold water supply.

It is essential that all systems function properly for optimum performance and if necessary, adjust the thermostatic blending valve to control the hot water outlet temperature between 50°C-55°C.

To achieve this the flow rate from each tap should be checked and a suitable number of taps run simultaneously to check the impact of this on the flow rate at individual taps.

We recommend that flow regulators are provided for each tap/terminal fitting to ensure that the available flow is shared evenly - See Appendix A for further details.

This product is covered by the 'Benchmark' scheme and a commissioning/service record is included in this manual. This must be completed during commissioning and left with the product to meet the Warranty conditions offered by Gledhill.

SERVICING

Important Do's and Don'ts

1. **DO** check the incoming mains water pressure. The preferred range of mains pressure is 2 -3 bar.
2. **DO** check the flow rate of the incoming cold water main is adequate to meet the maximum hot and cold water simultaneous demands.
3. **DO** check that all connections are in accordance with the labelling on the thermal store.
4. **DO NOT** switch on the immersion heaters until you have checked that the appliance is full of water ie there is water in the top up cistern.
5. **DO** check the water level is correctly set in the top up cistern when cold and (if fitted) that there is no discharge from the overflow when the appliance is up to temperature.
6. **DO** check that the immersion heater thermostats are set at approx 75°C (factory set).
7. **DO** insulate any exposed hot water pipework in the PulsaCoil BP cupboard and appliance.
8. If the ballvalve in the F & E cistern is permanently connected to the mains cold water supply **DO** plumb the overflow/warning pipe in a 20mm internal diameter pipe and ensure it discharges in a conspicuous external position. Use a material which is suitable for use with heating F & E cisterns in accordance with BS 5449 (such as copper).
9. **DO** ensure that the functioning and control of the system is explained to the occupant.
10. **DON'T** place any clothing or other combustible materials against or on top of this appliance.

These instructions should be placed along with the component manufacturers instructions in the pocket provided on the top of the appliance. The appliance should be left with the front panel fitted and screwed in position.

Annual Service

No annual servicing of the PulsaCoil BP is necessary.

However, if required, the operation of the controls and a hot water performance test can be carried out to prove the appliance is working satisfactorily and within its specification.

If it is decided to carry out the above tests the water level in the top cistern should also be checked and if necessary topped up.

Changing Components

Free of charge replacements for any faulty components are available from Gledhill during the in-warranty period on return of the faulty part (normally 12 months).

After this, spares can be obtained direct from Gledhill using the 'Speed Spares' service, or through any of the larger plumbers merchants/ specialist heating spares suppliers.

Help and advice is also available from the Technical Helpline on 0906 611 0005. Please note this is a premium rate line and will be charged accordingly.

However, all components are readily accessible and can be changed quickly and easily by the installer using common plumbing/electrical practice.

However all maintenance work on the PulsaCoil BP appliance must be carried out by a competent trades person.

SERVICING

	Description	Stock Code
1	Top immersion heater - Incolloy 825 immersion heater - with dual (control & safety) thermostat.	XB482
2	Bottom immersion heater - Incolloy 825 immersion heater - with dual (control & safety) thermostat.	XB482
3	Brawa mix thermostatic hot water blending valve	XC007
4	Scale inhibitor PCB	XB142
5	11" Safety Rod Stat	XB114



APPENDIX

Water Savings

Water Related Costs Can Be Reduced By Good Plumbing Practice

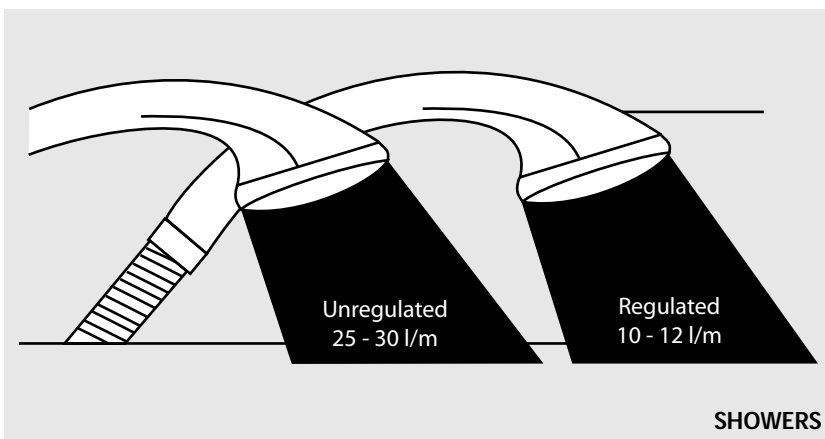
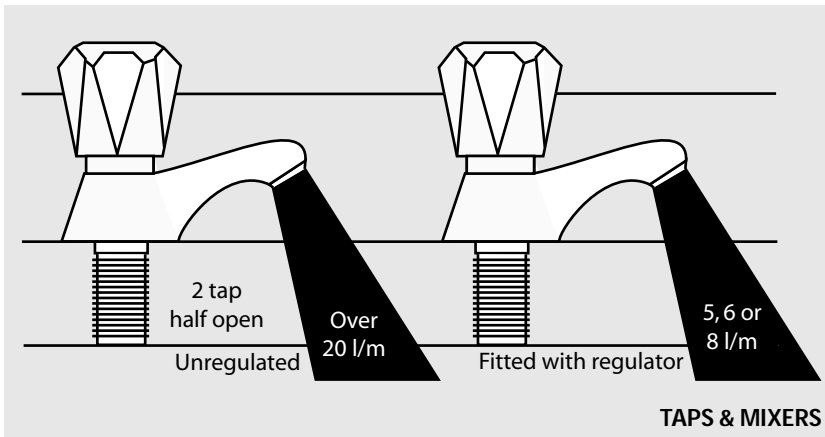

Vast quantities of water are needlessly run off to waste due to Taps, Mixers and Showers discharging flow rates far in excess of the rates required for them to perform their duties.

The contrasting flow rates shown on this leaflet clearly illustrate the savings that can be made whilst still providing a good performance.

British made Aquaflow Regulators provide constant flow rates by automatically compensating for supply pressure changes between 1 bar & 10 bars.

To facilitate installation into the wide range of plumbing equipment which is encountered in the U.K, Four Fixing Options are available:-

Options For Showers

1. MXF "DW" Range - For fitting behind Fixed Shower Heads or onto Flexible Hoses for Handshowers (preferably onto the inlet end when lightweight hoses are used).
2. Compression Fitting Range. "In Line" regulators as in Option 4 for Taps & Mixers.

Information by courtesy of
AQUAFLOW REGULATORS LTD

Haywood House, 40 New Road, Stourbridge, West Midlands DY8 1PA
TELEPHONE (01384) 442611 FAX: (01384) 442612

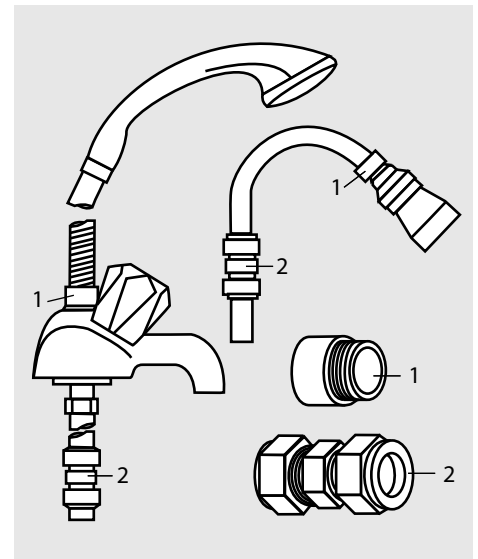

4 Fixing Options For Taps & Mixers

1. MK Range - Combined Regulators & Aerators for screwing onto Taps & Mixers with internal or external threads on their noses. Anti Vandal models also available.
2. MR05-T Range - Internal Regulators. Push-fit into Tap or Mixer seats. Produced in three sizes - 12.5mm (BS1010), 12mm & 10mm, Flangeless models also available for Taps with Low Lift washers.
3. MXF Standard Range - Screw on tail models for Taps & Mixers. Fix onto the tails before fitting the tap connectors. Available in 3/8", 1/2", 3/4" and 1" BSP.
4. Compression Fitting Range - "In Line" regulators housed in 15mm & 22mm CXC Couplers & Isolating Valves. "UKWFBS" listed by the Water Research Centre. Isolation valves available for slotted screwdriver operation or with coloured plastic handles. Now available also in plastic bodied push-fit couplers & valves.

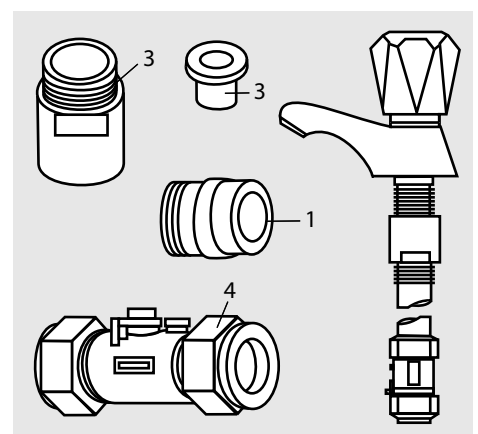

2 Inhibitor (Corrosion & scale protection of primary heating circuit)

On filling the heating system and before the boiler is fired up, it is important to ensure the system water is treated with a suitable corrosion inhibitor, in accordance with the boiler manufacturer's instructions.

Since the concentration of inhibitor present in a system can become diluted, for a number of different reasons, the system should be checked annually and re-treated as required, or after every full or partial drain-down. A water treatment manufacturer's test kit may be used to check the correct concentration of inhibitor in the system.

Where recommended by a boiler manufacturer, a 'physical corrosion protection device' may be fitted in the primary pipework in accordance with the boiler manufacturer's instructions.

The Benchmark checklist should be completed indicating the date and details of any of the above products added and a permanent label should be fixed to the system in a prominent location.

3 Scale protection (Domestic hot water service)

Where a combi boiler and/or a hot water storage vessel is installed in areas where the mains water can exceed 200ppm Total Hardness (as defined by BS 7593: 1993 Table 2) a scale reduction device should be installed, in accordance with the boiler manufacturer's instructions.

The levels of water hardness may be measured using a water hardness test kit.

BUILDING REGULATIONS

Completion of the Benchmark checklist requires that the 'competent person' undertaking the installation and commissioning provide information relating to Cleaning, Inhibitor and Scale Protection. This will demonstrate that the work complies with the requirements of the appropriate Building Regulations.

This Guidance Note is produced on behalf of its members by the Central Heating Information Council. For a full list of members visit www.centralheating.co.uk and for further advice on water treatment contact the following members:

 Culligan  Sentinel  Ferox  Salamander Engineering  Scalemaster

Heating & Hotwater Information Council, 36 Holly Walk, Leamington Spa,
Warwickshire CV32 4LY Tel: 0845 600 2200 Fax: 01926 423284
www.centralheating.co.uk

APPENDIX

MANUAL HANDLING OF APPLIANCE PRODUCTS

Description

Manual handling means any transporting or supporting of a load (including lifting, putting down, pushing, pulling, carrying or moving) by hand or bodily force.

Scope

This assessment will cover the largest unit within each product range manufactured by Gledhill.

For specific weights and dimensions please refer to technical data section.

Main Hazards

Vision may not be clear due to the size of the products. Adopting an incorrect method of lifting may cause injury, attempting to lift these products will require help from others. (Team lifts)

Control Measures

Manual lifting procedure

The lift, key factors in safe lifting are:

- a. **Balance**
 - b. **Position of back**
 - c. **Positioning of the arms and body**
 - d. **The hold**
 - e. **Taking the lead for team lifts**
-
- a. **Balance** - Since balance depends essentially upon the position of the feet, they should be apart about hip breadth with one foot advanced giving full balance sideways and forward without tension. In taking up this position, lifting is done by bending at the knees instead of the hips and the muscles that are brought into use are those of the thigh and not the back.
 - b. **Position of back** - Straight - not necessary vertical. The spine must be kept rigid, this coupled with a bent knee position, allows the centre line of gravity of the body to be over the weight so reducing strain.
 - c. **Positioning of arms and body** - The further arms are away from the side, the greater the strain on the shoulders, chest and back. Keep elbows close to the body arms should be straight.
 - d. **The hold** - Before lifting ensure you have a good hold. Two handles are provided on Appliance products at the top rear side, these allow one or two persons to have a purposely-designed hold at the top of the appliance to ensure easy lifting at the top of the product.

- e. **Taking the lead for team lifts**- As more than one person is required for these products ensure that one person is taking the lead. **This may be you** so ensure that each person that is helping is made aware of the weight and of the items listed within this assessment. Make sure you and any others helping know the route you intend to take that it is clear of any obstructions. Never jerk the load as this will add a little extra force and can cause severe strain to the arms, back and shoulders. If there are steps involved decide on where you will stop and take a rest period. Move smoothly and in unison taking care to look and listen to others helping with the lift. Where possible use a sack truck to move the product over long flat distances, only lift the products when necessary. If in doubt stop and get more help.

Individual capability

Individual capability plays an important part in handling these products. Persons above average build and strength will find it easier and should be in good health. Persons below average build and strength may require more rest periods during the handling process.

Pregnant women should not carry out this operation.

Persons who are not in good health should seek medical advice prior to commencing any lifting or manual handling operation.

Residual risk

Following the guidelines given above will reduce any risk to injury.

All persons carrying out this operation must be fully trained and copies of the specific risk assessment made available for inspection and use in their training process.

Further guidance on Manual Handling can be obtained from the Health and Safety Executive. Manual Handling Operations Regulations 1992.

SERVICE RECORD

It is recommended that your hot water system is serviced regularly and that the appropriate Service Record is completed.

Service Provider

Before completing the appropriate Service Record below, please ensure you have carried out the service as described in the manufacturer's instructions.

SERVICE 1 Date _____
Engineer Name _____
Company Name _____
Telephone Number _____
Comments _____

Signature _____

SERVICE 2 Date _____
Engineer Name _____
Company Name _____
Telephone Number _____
Comments _____

Signature _____

SERVICE 3 Date _____
Engineer Name _____
Company Name _____
Telephone Number _____
Comments _____

Signature _____

SERVICE 4 Date _____
Engineer Name _____
Company Name _____
Telephone Number _____
Comments _____

Signature _____

SERVICE 5 Date _____
Engineer Name _____
Company Name _____
Telephone Number _____
Comments _____

Signature _____

SERVICE 6 Date _____
Engineer Name _____
Company Name _____
Telephone Number _____
Comments _____

Signature _____

SERVICE 7 Date _____
Engineer Name _____
Company Name _____
Telephone Number _____
Comments _____

Signature _____

SERVICE 8 Date _____
Engineer Name _____
Company Name _____
Telephone Number _____
Comments _____

Signature _____

SERVICE 9 Date _____
Engineer Name _____
Company Name _____
Telephone Number _____
Comments _____

Signature _____

SERVICE 10 Date _____
Engineer Name _____
Company Name _____
Telephone Number _____
Comments _____

Signature _____

Gledhill (Building Products) Ltd

AMD, SEPTEMBER 2010

CONDITIONS OF SALE & GUARANTEE TERMS

1. Gledhill (Building Products) Ltd ("We" or "Gledhills") only do business upon the Conditions which appear below and no other. Unless we so agree in writing these Conditions shall apply in full to any supply of goods by us to the exclusion of any Conditions or terms sought to be imposed by any purchaser. These Conditions of Sale and Warranty Terms override those which are contained on the Invoice Forms and all Sales are now subject to these Conditions of Sale and Warranty terms only.

2. PRICE

Once an order or call off has been accepted the price will be held for three months **but if delivery is extended beyond that period at the customer's request, then we reserve the right to amend the price when necessary.** The company reviews its pricing annually to adjust for changes in our cost base. We reserve the right to alter prices at any time for severe movements in raw materials (mainly copper and steel). If there is to be a change we will give customers at least four weeks notice but anything delivered after that date will be at the revised price. An order may not be cancelled or varied after acceptance without the written consent of the company. Such cancellation or variation shall be subject to such reasonable charges as may be appropriate.

3. SPECIFICATION

The goods are supplied in accordance with the Specifications (if any) submitted to the Purchaser and any additions and alterations shall be the subject of an extra charge. Any goods not so specified shall be in accordance with our printed literature or the literature of any of our component suppliers (subject to any modifications made since publication). If we adopt any changes in construction or design of the goods, or in the specification printed in our literature, the Purchaser shall accept the goods so changed in fulfilment of the order.

4. PAYMENT

The buyer shall make payment in full within thirty days from the end of the month in which the invoice is dated. If we receive payment in full on or before the due date we will allow an appropriate settlement discount except where we have quoted a special net price. If payment is not received in full on or before the due date we shall be entitled in addition to the invoice price to:

- (i) payment of a sum equal to any increase in the copper price supplement applicable to the particular goods sold between the date of receipt of order and the date of receipt of payment in full; and
- (ii) interest on any part of the invoice price unpaid after the due date at the rate of 3% per annum over the base rate for the time being of HSBC Bank plc.

5. TIME

We give estimates of delivery dates in good faith and time of delivery is not nor shall be made of the essence of any contract nor shall we be liable for any loss or damage occasioned by delay in delivery.

6. DELIVERY

We deliver free normally by our own vehicles within 25 miles of any of our manufacturing depots. Delivery to any place more than 25 miles from one of our manufacturing depots may be subject to our quoted delivery charges. We reserve the right to make delivery of goods contained in one order by more than one consignment and at different times. Where a period is agreed for delivery and such period is not extended by our Agreement, the Purchaser shall take delivery within that period. If the Purchaser fails to take delivery, we shall be entitled at the Purchaser's risk and expense to store the goods at the Purchaser's premises or elsewhere and to demand payment as if they had been despatched. Off loading at point of delivery shall be the responsibility of and be undertaken by the Purchaser.

7. SHORTAGES OR DAMAGE

Goods must be inspected before signature of delivery note and any damage, shortage or discrepancy noted on the delivery note and the goods returned on the same vehicle. The buyer must also give us immediate written notice of the damage, shortage or discrepancy so that we may prompt investigation.

8. RETURN OF GOODS

Goods may not be returned to the Company except by prior written permission of an authorised officer of the Company and such return shall be subject to payment by the Purchaser of handling and re-stocking charges, transport and all other costs incurred by the Company.

9. COMPANY LIABILITY AND GUARANTEE

9.1. Subject to the terms of these Conditions of Sale and Guarantee Terms Gledhills provide Guarantees in respect of specific products as set out in this clause.

9.2. Each Guarantee is strictly conditional upon the following:-

9.2.1. Complaints must be given to us immediately, before any action is taken, as responsibility cannot be accepted if repairs or renewals are attempted on site without our written approval.

9.2.2. The unit has been installed in accordance with our installation and service instructions and all relevant codes of practice and regulations in force at the time of installation.

9.2.3. All necessary inlet controls and safety valves have been fitted correctly.

9.2.4. The unit has only been used for the storage of potable water supplied from the public mains.

9.2.5. Where appropriate the unit has been regularly maintained as detailed in the installation and service instructions

9.2.6. Defects caused by corrosion or scale deposits are not covered by any Guarantee.

9.2.7. Where we agree to rectify any defect we reserve the right to undertake the work on our own premises.

9.2.8. We will not accept any labour charges associated with replacing the unit or parts for any of the following products listed.

9.3. Guarantees are provided in respect of specified goods supplied by Gledhills as follows:-

(a) Domestic and Commercial Open Vented Cylinders and Tanks.

The copper storage vessel is guaranteed for ten years and if it proves to be defective either in materials or workmanship, we will either repair or supply replacement at our option with the closest substitute in the case of any obsolete product to any address in Great Britain.

(i) free of all charge during the first year after delivery by us.

(ii) thereafter at a charge of one-tenth of the then current list price and any copper price supplement and delivery charge during the second year after delivery by us and increasing by a further one-tenth on the second and subsequent anniversary of delivery by us.

(b) Domestic Mains Fed Products [Primary Stores]

The copper storage vessel is guaranteed for five years and if it or any integral pipework as part of the storage vessel assembly proves to be defective either in materials or workmanship, we reserve the right to either repair or supply replacements or the closest possible substitute in the case of any obsolete product and will collect and deliver to any address in England, Wales and Scotland (excluding all Scottish Islands).

(i) free of all charge during the first year after delivery by us.

(ii) thereafter at a charge of one-fifth of the then current list price or any copper price supplement and delivery charge during the second year after delivery by us increasing by a further one-fifth on the second and subsequent anniversary of delivery by us.

(c) Stainless Steel Unvented Cylinders

Gledhill guarantee the components including controls, valves and electrical parts for two years from the date of purchase. IT SHOULD BE NOTED THAT THE FACTORY FITTED TEMPERATURE AND PRESSURE RELIEF VALVE MUST NOT BE REMOVED OR ALTERED IN ANY WAY OR THE GUARANTEE WILL NOT BE VALID. GLEDHILL WILL NOT BE RESPONSIBLE FOR ANY CONSEQUENTIAL LOSS OR DAMAGE HOWEVER IT IS CAUSED.

The guarantee for the stainless steel vessel is for twenty five years if the original unit is returned to us **AND PROVIDED THAT:**

- (i) It has not been modified, other than by Gledhill.
- (ii) It has not been subjected to wrong or improper use or left uncared for.
- (iii) It has only been used for the storage of potable water, max 200mg/litre chloride.
- (iv) It has not been subjected to frost damage.
- (v) The benchmark service record is completed after each annual service.
- (vi) The unit has been serviced annually.
- (vii) Any disinfection has been carried out strictly in accordance with BS6700.

If the stainless steel vessel proves to be defective either in materials or workmanship we reserve the right to either repair or supply replacements or the closest possible substitute in the case of any obsolete product and will collect and deliver to any address in England, Scotland and Wales (excluding all islands):

- (i) free of charge during the first year after delivery by us.
- (ii) thereafter at a charge of one twenty fifth of the then current list price during the second year after delivery by us and increasing by a further one twenty fifth on the second and subsequent anniversary of delivery by us.

ACTION IN THE EVENT OF FAILURE

If the stainless steel cylinder develops a leak we will ask for a deposit against the supply of a new one. This will be refunded if the failure is within the terms of the warranty when it has been examined by us.

Please note:

- Installation must have been carried out by a licensed specialized company (heating contractor or plumber) following the version of installation instructions in force.
- Gledhill or its representative was given the opportunity to check complaints on site immediately after any defect occurred.
- Confirmation exists that the system was commissioned properly and that the system was checked and maintenance was performed annually by a specialised company licensed for this purpose.

(d) Components of our products other than Storage Vessels and Integral Pipework.

We will either extend to the purchaser the same terms of warranty as we are given by the manufacturer of the component or if the manufacturer does not give any warranty, replace free of charge any component which becomes defective within two years after the date of the delivery by us and is returned to us at the purchaser's expense but we shall not meet the cost of removal or shipping or return of the component or any other cost charges or damages incurred by the purchaser.

9.4.

9.4.1. In respect of goods supplied by us and in respect of any installation work carried out by or on our behalf, our entire liability and the purchaser's sole remedies (subject to the Guarantees) shall be as follows:-

- (a) We accept liability for death or personal injury to the extent that it results from our negligence or that of our employees
- (b) Subject to the other provisions of this clause 9 we accept liability for direct physical damage to tangible property to the extent that such damage is caused by our negligence or that of our employees, agents or subcontractors.

- (c) Our total liability to the purchaser over and above any liability to replace under the Guarantees (whether in contract or in tort including negligence) in respect of any one cause of loss or damage claimed to result from any breach of our obligations hereunder, shall be limited to actual money damages which shall not exceed £20,000 provided that such monetary limit shall not apply to any liability on the part of ourselves referred to in paragraph (a) above
- (d) Except as provided in paragraph (a) above but otherwise notwithstanding any provision herein contained in no event shall we be liable for the following loss or damage howsoever caused and even if foreseeable by us or in our contemplation:-
 - (i) economic loss which shall include loss of profits, business revenue, goodwill or anticipated savings
 - (ii) damages in respect of special indirect or consequential loss or damage (other than death, personal injury and damage to tangible property)
 - (iii) any claim made against the purchaser by any other party (save as expressly provided in paragraph (b) above)
- (e) Except in respect of our liability referred to in paragraph (a) above no claim may be made or action brought (whether in contract or in tort including negligence) by the purchaser in respect of any goods supplied by us more than one year after the date of the invoice for the relevant goods.
- (f) Without prejudice to any other term we shall not be liable for any water damage caused directly or indirectly as a result of any leak or other defect in the goods. We cannot control the conditions of use of the goods or the time or manner or location in which they will be installed and the purchaser agrees to be fully responsible for testing and checking all works which include the goods at all relevant times (up to, including and after commissioning) and for taking all necessary steps to identify any leaks and prevent any damage being caused thereby.
- (g) Nothing in these Conditions shall confer on the purchaser any rights or remedies to which the purchaser would not otherwise be legally entitled

10. LOSS OR INJURY

Notwithstanding any other provision contained herein the purchaser's hereby agree to fully indemnify us against any damages losses costs claims or expenses incurred by us in respect of any claim brought against us by any third party for:-

- (a) any loss injury or damage wholly or partly caused by any goods supplied by us or their use.
- (b) any loss injury or damage wholly or partly caused by the defective installation or substandard workmanship or materials used in the installation of any goods supplied by us.
- (c) any loss injury or damage in any way connected with the performance of this contract.
- (d) any loss resulting from any failure by the purchaser to comply with its obligations under these terms as to install and/or check works correctly.

PROVIDED that this paragraph will not require the purchaser to indemnify us against any liability for our own acts of negligence or those of our employees agents or sub-contractors

FURTHER in the case of goods supplied by us which are re-sold and installed by a third party by the purchaser it will be the sole responsibility of the purchaser to test the goods immediately after their installation to ensure that inter alia they are correctly installed and in proper working order free from leaks and are not likely to cause any loss injury or damage to any person or property.

11. VARIATION OF WARRANTY AND EXCLUSION

Should our warranty and exclusion be unacceptable we are prepared to negotiate for variation in their terms but only on the basis of an increase in the price to allow for any additional liability or risk which may result from the variation. Purchasers are advised to insure against any risk or liability which they may incur and which is not covered by our warranty.

12. ADVICE

Any advice or assistance given by the Company is provided without charge and is in good faith without undertaking, representation or warranty, and we will not accept any liability, whether consequential or compensatory, for advice or assistance given.

13. RISK AND RETENTION OF TITLE

- (a) goods supplied by us shall be at the Purchaser's risk immediately upon delivery to the Purchaser or into custody on the Purchaser's behalf or to the Purchaser's Order. The Purchaser shall effect adequate insurance of the goods against all risks to the full invoice value of the goods, such insurance to be effective from the time of delivery until property in the goods shall pass to the Purchaser as hereinafter provided.
- (b) property in the goods supplied hereunder will pass to the Purchaser when full payment has been made by the Purchaser to us for :-
 - (i) the goods of the subject of this contract.
 - (ii) all other goods the subject to of any other contract between the Purchaser and us which, at the time of payment of the full price of the goods sold under this contract, have been delivered to the Purchaser but not paid for in full.
- (c) until property in the goods supplied hereunder passes to the Purchaser in accordance with paragraph (2) above.
 - (i) the Purchaser shall hold the goods in a fiduciary capacity for us and shall store the same separately from any other goods in the Purchaser's possession and in a manner which enables them to be identified as our goods.
 - (ii) the Purchaser shall immediately return the goods to us should our authorised representative so request. All the necessary incidents associated with a fiduciary relationship shall apply.
- (d) the Purchaser's right to possess the goods shall cease forthwith upon the happening of any of the following events, namely :-
 - (i) if the Purchaser fails to make payment in full for the goods within the time stipulated in clause 4 hereof.
 - (ii) if the Purchaser, not being a company, commits any act of bankruptcy, makes a proposal to his or her creditors for a compromise or does anything which would entitle a petition for a Bankruptcy Order to be presented.
 - (iii) if the Purchaser, being a company, does anything or fails to do anything which would entitle an administrator or an administrative receiver or a receiver to take possession of any assets or which would entitle any person to present a petition for winding up or to apply for an administration order.
- (e) the Purchaser hereby grants to us an irrevocable licence to enter at any time any vehicle or premises owned or occupied by the Purchaser or in the possession of the Purchaser for the purposes of repossessing and recovering any such goods the property in which has remained in us under paragraph (2) above. We shall not be responsible for and the Purchaser will indemnify us against liability in respect of damage caused to any vehicle or premises in such repossession and removal being damaged which it was not reasonably practicable to avoid.
- (f) notwithstanding paragraph (3) hereof and subject to paragraph (7) hereof, the Purchaser shall be permitted to

sell the goods to third parties in the normal course of business. In this respect the Purchaser shall act in the capacity of our commission agent and the proceeds of such sale :-

- (i) shall be held in trust for us in a manner which enables such proceeds to be identified as such, and :
 - (ii) shall not be mixed with other monies nor paid into an overdrawn bank account.
- We, as principal, shall remunerate the Purchaser as commission agent a commission depending upon the surplus which the Purchaser can obtain over and above the sum, stipulated in this contract of supply which will satisfy us.
- (g) in the event that the Purchaser shall sell any of the goods pursuant to clause (6) hereof, the Purchaser shall forthwith inform us in writing of such sale and of the identity and address of the third party to whom the goods have been sold.

- (h) if, before property in the goods passes to the Purchaser under paragraph (2) above the goods are or become affixed to any land or building owned by the Purchaser it is hereby agreed and declared that such affixation shall not have the effect of passing property in the goods to the Purchaser. Furthermore if, before property in the goods shall pass to the Purchaser under paragraph (2) hereof, the goods are or become affixed to any land or building (whether or not owned by the Purchaser), the Purchaser shall:-

- (i) ensure that the goods are capable of being removed without material injury to such land or building.
- (ii) take all necessary steps to prevent title to the goods from passing to the landlord of such land or building.
- (iii) forthwith inform us in writing of such affixation and of the address of the land or building concerned.

The Purchaser warrants to repair and make good any damage caused by the affixation of the goods to or their removal from any land or building and to indemnify us against all loss damage or liability we may incur or sustain as a result of affixation or removal.

- (i) in the event that, before property in the goods has passed to the Purchaser under paragraph (2) hereof, the goods or any of them are lost, stolen, damaged or destroyed :-
- (ii) the Purchaser shall forthwith inform us in writing of the fact and circumstances of such loss, theft, damage or destruction.
- (iii) the Purchaser shall assign to us the benefit of any insurance claim in respect of the goods so lost, stolen, damaged or destroyed.

14. NON-PAYMENT

If the Purchaser shall fail to make full payment for the goods supplied hereunder within the time stipulated in clause 4 hereof or be in default of payment for any other reason then, without prejudice to any of our other rights hereunder, we shall be entitled to stop all deliveries of goods and materials to the Purchaser, including deliveries or further deliveries of goods under this contract. In addition we shall be entitled to terminate all outstanding orders.

15. VALUE ADDED TAX

All prices quoted are exclusive of Value Added Tax which will be charged at the rate ruling at the date of despatch of invoice.

16. TRADE SALES ONLY

We are only prepared to deal with those who are not consumers within the terms of the Unfair Contract Terms Act 1977, the Sale of Goods Act 1979 and the Supply of Goods and Services Act 1982. Accordingly any person who purchases from us shall be deemed to have represented that he is not a consumer by so purchasing.

17. JURISDICTION

The agreement is subject to English law for products delivered in England and Scottish law for products delivered in Scotland and any dispute hereunder shall be settled in accordance therewith dependent upon the location.

18. PRODUCT DEVELOPMENT

Gledhill have a policy of continuous product development and may introduce product modifications from time to time.

Providing peace of mind

On expiry of your initial warranty period, Gledhill Response Limited would be pleased to provide further customer support with a range of services including:

Low cost annual repair and maintenance contracts direct from Gledhill

Annual servicing and safety checks

Expert response to 'out of warranty' breakdowns at fixed charges

Please ring 08445 679898 or visit www.gledhill.net for further details



Gledhill Building Products Limited

Sycamore Estate, Squires Gate, Blackpool FY4 3RL Tel: 01253 474550 Fax: 01253 474551 sales@gledhill.net

Gledhill Building Products produce cylinders for use with a wide range of heat sources including;

Gas and oil boilers
Ground source heat pumps

Electricity
Solar energy

Air source heat pumps
Wood burning stoves

For further information of Gledhill products can be found on the internet at www.gledhill.net



"Only the best is acceptable"



FM 2057
Gledhill cylinders are produced under an ISO 9001:2008 Quality System accepted by BSI



To protect our environment, we use copper a totally recyclable metal, which never becomes waste.



THE MARK OF QUALITY FOR THE INSTALLATION, COMMISSIONING AND SERVICING OF DOMESTIC HEATING AND HOT WATER SYSTEMS



Due to a programme of continuous improvement Gledhill Building Products reserve the right to modify products without prior notice. It is advisable to check the product technical detail by using the latest design and installation manuals available from our technical support team or on our website.