



STUDIO

Conventional Flue - Stone Chippings and Log

Instructions for Use, Installation and Servicing

For use in GB, IE (Great Britain and Republic of Ireland)

IMPORTANT

This product contains a Heat resistant glass panel. This panel should be checked during Installation and at each servicing interval. If any damage is observed on the front face of the glass panel (scratches, scores, cracks or other surface defects), the glass panel must be replaced and the appliance must not be used until a replacement is installed. Under no circumstances should the appliance be used if any damage is observed, the glass panel is removed or broken.

Parts of this appliance will become hot during operation; it is therefore recommended that a suitable guard should be used for protection of young children, the elderly or infirm.

This appliance is guaranteed for 2 years (subject to the conditions on page 3 of this Instruction manual). The second year of the guarantee will only be valid if the annual service recommended in this Instruction manual has been completed by a GasSafe registered engineer, and a copy of the service report is available for inspection by a Gazco engineer.

These Instructions must be left with the appliance for future reference and for consultation when servicing the appliance. Please make the customer aware of the correct operation of the appliance before leaving these instructions with them.

The commissioning sheet found on Page 3 of this Instruction manual must be completed by the Installer prior to leaving the premises.

COVERING THE FOLLOWING MODELS:

STUDIO 1 CONVENTIONAL FLUE STUDIO 2 CONVENTIONAL FLUE

	PAGE
APPLIANCE COMMISSIONING CHECKLIST	3
USER INSTRUCTIONS	4
INSTALLATION INSTRUCTIONS	14
Technical Specifications - Stone Chippings Version	14
Technical Specifications - Log Version	15
Site Requirements	18
Installation	20
Commissioning	39
SERVICING INSTRUCTIONS	40
Fault Finding	40
How to replace parts	43
Basic spare parts list - Stone Chippings Version	50
Basic spare parts list - Log Version	51
Service Records	52

APPLIANCE COMMISSIONING CHECKLIST

IMPORTANT NOTICE

Explain the operation of the appliance to the end user, hand the completed instructions to them for safe keeping, as the information will be required when making any guaranteed claims.

FLUE CHECK	PASS	FAIL
1. Flue is correct for appliance		
2. Flue flow test		
3. Spillage test		
GAS CHECK		
1. Gas soundness & let by test		
2. Standing pressure test	mb	
3. Appliance working pressure (on High Setting) NB All other gas appliances must be operating on full	mb	
4. Gas rate	m ³ /h	
5. Does ventilation meet appliance requirements		

DEALER AND INSTALLER INFORMATION

Dealer

Installation Company

Contact No.

Engineer

Date of Purchase

Contact No.

Model No.

Gas Safe Reg No.

Serial No.

Date of Installation

Gas Type

This product is guaranteed for 2 years from the date of installation, as set out in the terms and conditions of sale between Gazco and your local Gazco dealer. **This guarantee will be invalid, to the extent permitted by law, if the above Appliance Commissioning Checklist is not fully completed by the installer and available for inspection by a Gazco engineer.** The guarantee will only be valid during the second year, to the extent permitted by law, if the annual service recommended in the Instructions for Use has been completed by a Gas Safe registered engineer, and a copy of the service visit report is available for inspection by a Gazco engineer.

USER INSTRUCTIONS

1. GENERAL

In the event of a gas escape or if you can smell gas, please take the following steps:

- Immediately turn off the gas supply at the meter/emergency control valve
- Extinguish all sources of ignition
- Do not smoke
- Do not operate any electrical light or power switches (On or Off)
- Ventilate the building(s) by opening doors and windows
- Ensure access to the premises can be made

Please report the incident immediately to the National Gas Emergency Service Call Centre on 0800 111 999 (England, Scotland and Wales) , 0800 002 001 (N. Ireland) or in the case of LPG, the gas supplier whose details can be found on the bulk storage vessel or cylinder.

The gas supply must not be used until remedial action has been taken to correct the defect and the installation has been recommissioned by a competent person.

- 1.1 Installation and servicing must only be carried out by a competent person whose name appears on the Gas Safe register. To ensure the engineer is registered with Gas Safe they should possess an ID Card carrying the following logo:



- 1.2 In all correspondence, please quote the appliance type and serial number, which can be found on the data badge located on a plate attached to the lower slotted trim.
- 1.3 **Do not** place curtains above the appliance: You must have 300mm (1') clearance between the appliance and any curtains at either side.
- 1.4 If any cracks appear in the glass panel do not use the appliance until the panel has been replaced.
- 1.5 In the unlikely event the appliance is receiving interference from other electronic devices, the handset/Control box can be reprogrammed. Please consult your dealer if you think this may be the case.
- 1.6 This product is guaranteed for 2 years from the date of

installation, as set out in the terms and conditions of sale between Gazco and your local Gazco dealer. Please consult with your local Gazco dealer if you have any questions. In all correspondence always quote the Model Number and Serial Number.

IMPORTANT : NEVER position an LCD/Plasma TV above this appliance.

2. OPERATING THE APPLIANCE

- 2.1 The appliance can be operated in two ways:
- Using the fully programmable remote control unit.
 - Using the touch pad control on the wall switch.
- 2.2 The appliance has four flame settings which can be controlled manually or automatically via temperature sensing:
1. Standby (Pilot only).
 2. Low (Pilot lit and main burner lit at the minimum flame setting).
 3. Med (Pilot lit and main burner lit at the medium flame setting).
 4. High (Pilot lit and main burner lit at the highest flame setting).

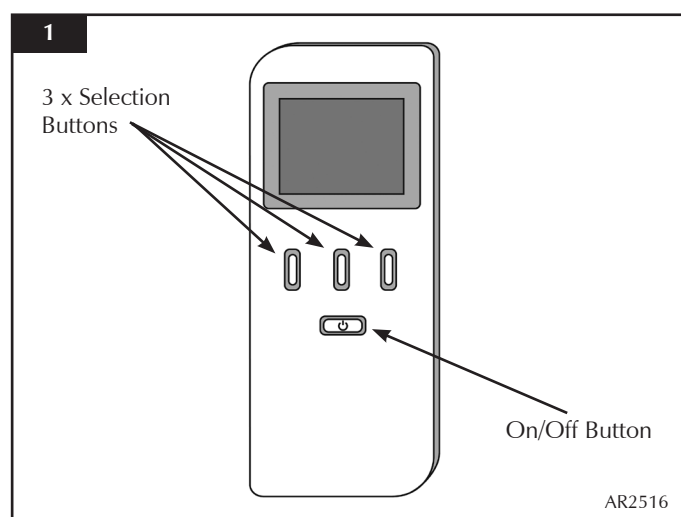

2A. FULLY PROGRAMMABLE REMOTE CONTROL HANDSET

- 2.3 The remote control handset has been factory set to only communicate with the appliance it is supplied with. The appliance will not respond to any other remote control, even one from an identical appliance.

USER INSTRUCTIONS

Note: In the event of a replacement handset being acquired, pairing of the handset with the appliance will need to be carried out. Please refer to Commissioning, Section 2, Pairing Handset on page 39.

2.4 The handset has been factory configured with the following options:

a) Auto thermostat mode enabled - the flame height will alter automatically to achieve a desired room temperature (when set).

b) Gap temperature set at 2°C - if the handset temperature display falls 2°C below the fixed temperature when in standby mode (pilot only) the appliance will automatically ignite the main burner at the low flame setting.

c) Programming - allowing a daily or weekly program of operation to be set.

d) Soft start enabled - in thermostat mode there is a 10 second delay between flame settings when more than one change of setting is required (i.e. from High to Low).

e) Sounder ON - accepted operations via the handset will initiate a beep from the appliance control).

f) Safety Temperature - pre-set to switch the appliance off if the remote temperature display exceeds 40°C.

Before using the remote control:

2.5 Ensure batteries are fitted (2x AA 1.5v high quality (Duracell or similar) alkaline - DO NOT USE RECHARGEABLE).

2.6 If there is no display on the LCD screen press any key.

NOTE: To select a function from the options displayed at the bottom of the screen press the button directly below the desired function (see Diagram 2).

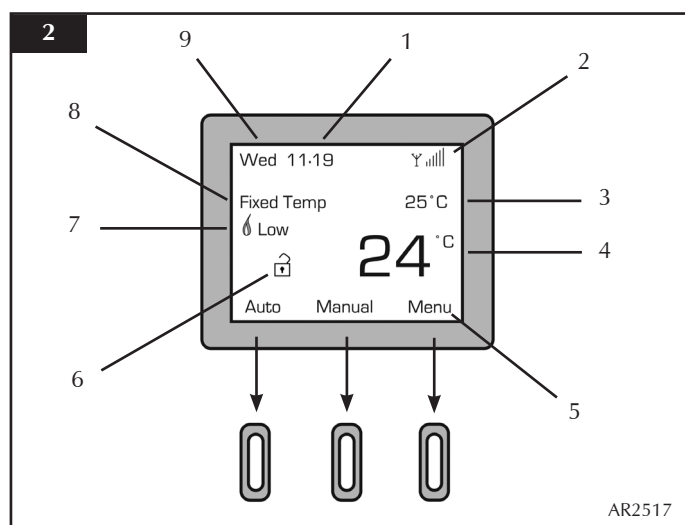

2.7 When first powered, the handset displays the OFF screen. The handset may also be locked as indicated by the symbol (🔒).

2.8 To unlock the handset select Unlock followed by OK - the symbol will change to (🔓).

2.9 The LCD screen displays the following information (see Diagram 2):

- 1) Time
- 2) Signal strength (between handset and appliance)
- 3) Selected Setting - selected flame setting (highlighted) or desired temperature if in auto mode
- 4) Current room temperature
- 5) Button function
- 6) Child lock status
- 7) Current flame status
- 8) Selected Mode - Manual / Auto (Thermo / Fixed Temp) / Program - when appliance is switched on
- 9) Day of the week

To set or adjust the items on the display:

2.10 Select Menu from the bottom right of the main screen.

2.11 Select Adjust Menu.

In this menu it is possible to set the:

Temperature Unit (°C or °F)
 Language
 Autolock (On/Off)
 Day
 Hour
 Minute
 Comfort temperature
 Night temperature

In addition access can be gained to the programmable functions via the Change Prog option (see Section 2C).

Note: The current day and time must be set in order for the programmable functions to work.

2.12 Using the button below the symbol (↓) scroll down to Day and press the button below Select. Use the buttons below the symbols (↑) and (↓) to set the day of the week.

2.13 Press the button below Back, scroll down to Hour and select it. Use the buttons below the symbols (↑) and (↓) to set the hour.

2.14 Press the button below Back, scroll down to Minute and select it. Use the buttons below the symbols (↑) and (↓) to set the minutes.

USER INSTRUCTIONS

2.15 The same process can be used to set any of the functions within this menu.

2.16 There are 3 different modes available for controlling and operating the appliance:

1. Manual Mode
2. Automatic Mode
3. Program Mode

Refer to Section 2B for full details.

NOTE: WHEN OPERATING THE APPLIANCE IN AUTOMATIC OR PROGRAM MODE, THE PILOT REMAINS LIT AND THE MAIN BURNER AUTOMATICALLY SWITCHES ON AT PROGRAMMED TIMES TO BRING THE ROOM TO THE SET TEMPERATURE WHETHER OR NOT YOU ARE IN THE ROOM. NEVER LEAVE ANY COMBUSTIBLE MATERIALS WITHIN 1 METRE OF THE FRONT OF THE APPLIANCE.

2B. SETTING THE MODE OF OPERATION

1. Manual Mode

The Manual mode can be used to turn the appliance on and alter flame height and, therefore, temperature.

To use the manual mode of operation:

2.17 If there is no display on the LCD screen press any key.

If the appliance is off (no pilot flame) the handset will display the word OFF.

The handset may also be locked as indicated by the symbol (🔒).

2.18 To unlock the handset select Unlock followed by OK - the symbol will change to (🔓).

2.19 Select On followed by OK. The appliance will emit a single beep and the pilot will light.

Note: There may be a slight delay between pressing the remote and the appliance responding.

2.20 Select Manual and the screen will highlight the current flame setting (Pilot).

2.21 To light the main burner select (↑). The screen will highlight the current flame setting (Low) and the main burner will light at the Low setting.

2.22 Use the buttons directly below the symbols (↓) and (↑) to increase or decrease the flame setting between the Pilot and the High setting.

2.23 To turn off the appliance press the ON/OFF button once (see Diagram 1).

2.24 To lock the handset select Lock.

NOTE: If the Safety Temperature (see Section 2.4 f) is exceeded then the appliance will turn itself off. The appliance can not be turned on again until the room temperature has dropped below the safety temperature.

2. Auto Mode

The auto mode of operation allows the user to pre-set the desired room temperature. The appliance will control the flame setting automatically to maintain this temperature.

To use the auto mode of operation:

2.25 If there is no display on the LCD screen press any key.

2.26 If the appliance is off (no pilot flame) the handset will display the word OFF.

2.27 The handset may also be locked as indicated by the symbol (🔒).

2.28 To unlock the handset select Unlock followed by OK - the symbol will change to (🔓).

2.29 Select On followed by OK. The appliance will emit a single beep and the pilot will light.

2.30 Select Auto. The screen will display the word Thermo and the set room temperature will be highlighted.

2.31 To adjust the desired room temperature use the buttons directly below the symbols (↓) and (↑). The set temperature can be adjusted between 0°C and 37°C.

The flame setting required to achieve the desired room temperature will be displayed below the word Thermo.

2.32 In accordance with the factory configurations the following will apply:

a) For every 1°C below the set temperature the flame height will increase.

b) For every 1°C above the set temperature the flame height will decrease.

c) There will be a delay of 10 seconds between each automatic flame setting adjustment.

2.33 Once the desired room temperature has been set, select Back to return to the main screen.

2.34 The main screen will now display the words Fixed Temp, the set temperature (e.g. 21°C) and the current room temperature (largest number). To change the set temperature at any time select Auto and follow 2.31 above.

USER INSTRUCTIONS

- 2.35 To exit the Auto mode at any time select Manual from the bottom of the screen and follow Section 2.18 - 2.25.

3. Program Mode

The program mode of operation allows the appliance to be pre-set to a choice of temperature options on a daily or weekly cycle. The appliance will automatically operate and control the flame setting to maintain pre-set hourly temperatures during each 24hr period. **To set a daily row weekly program please refer to Section 2C.**

LOW BATTERY

If the batteries in the remote control handset become discharged the LCD display will show the message Low Battery.

NOTE: Only replace the handset batteries with high quality (Duracell or similar) type AA 1.5v alkaline. Do not use rechargeable batteries.

REMOTE SIGNAL STRENGTH

- 2.36 If the appliance does not respond to the handset, check the strength of the reception signal in the top right hand corner of the LCD display (Y||||).

If there are no vertical bars next to the signal symbol (Y) then communication between the appliance and the handset has been lost. If the communication loss exceeds 18 minutes then the appliance will emit 20 beeps and switch OFF. Try the following:

- 2.37 Move the handset closer to the appliance.

NOTE: Try to avoid placing the handset a long distance from the appliance. It can take some time for the signal to return.

- 2.38 Replace the batteries in the handset.
- 2.39 If there is still no signal, operate the appliance using the touch pad control on the wall switch (refer to Section 2D) and consult your installer or Gazco dealer.

2C. PROGRAM MENU

- 2.40 The program menu can be used to pre-set the appliance to function automatically.

There are two types of program mode:

1. Daily mode - the temperature can be selected (from a range of settings) for each hour over a 24hr period - the set pattern is then repeated every day.
2. Weekly mode - the temperature can be selected (from a range of settings) for each hour over a 24hr period for each individual day of the week (Mon - Sun).

Note: In order for the programmable functions to work the current day and time must be set first, see Section 2.11.

- 2.41 One of 3 pre-set temperature options can be chosen for each hour across the 24 hour period:
- Off - the appliance will remain in Standby mode (pilot only - please note the appliance will not switch off completely when in program mode)
 - Night Temp - the appliance will operate automatically to maintain the pre-set night temperature.
 - Comfort Temp - the appliance will operate automatically to maintain the pre-set comfort temperature.
- 2.42 To set the Comfort and Night temperature refer to Section 2.11.
- 2.43 To access the program menu select Menu. In the next screen select Adjust Menu. Use the button directly below the symbol (↓) scroll to Change Prog and select. The programming screen will be displayed as shown in Diagram 3.

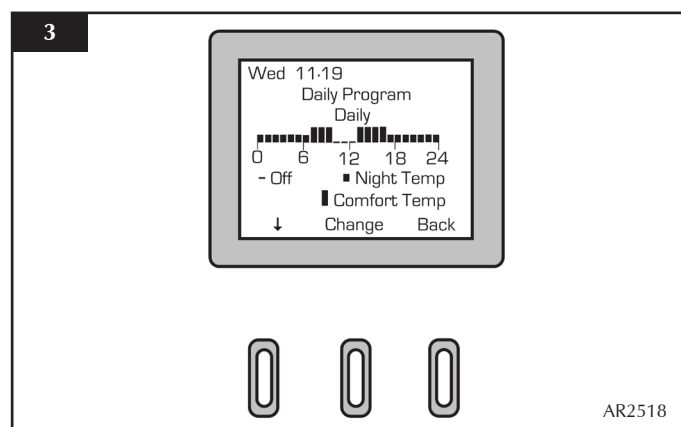

To set a Daily program of operating times:

- 2.44 In the program menu the word Daily should be highlighted. Press the button below the symbol (↓) to access the 24 hour timer (see Diagram 3). The arrow should now point to the right (→).
- 2.45 The timer reads 0 - 24 with 0 representing midnight. Press the button below the symbol (→) to scroll through the 24 hour timer. With the cursor resting on the chosen hour, press Change until you have reached the desired setting for that hour. Use the button below the symbol (→) to scroll to the next hour and select the desired function for each hour until all 24 hours are set.

To set a weekly program of operating times:

- 2.46 Select the day of the week (Mon - Sun) using the button below the word Change. Select the function settings for each hour of the given day as detailed in 2.45 above.

USER INSTRUCTIONS

- 2.47 Once the programming is completed select Back to return to the main screen.

To launch the program:

Note: The appliance must be ON (pilot lit or any flame setting) in order to launch the program.

- 2.48 Select Menu. In the next screen use the button directly below the symbol (↓) to scroll to Program and select it. Select Change until the highlighted text reads ON.
- 2.49 Select Back and use the button directly below the symbol (↓) to select Prog Type. Press the button directly below the word Select followed by Change until the desired program (Daily or Weekly) is selected. Select Back twice to return to the main screen.

2D. TOUCH PAD CONTROL

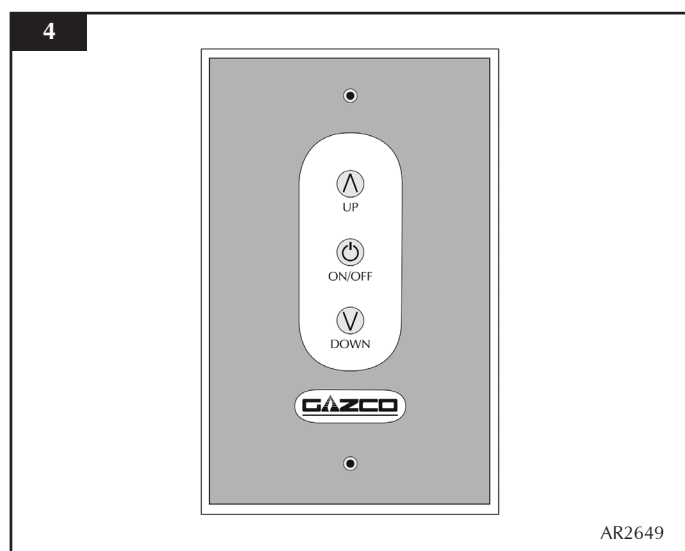

The touch pad control is located on the front of the wall switch and allows manual operation of the appliance (see Diagram 4).

With the touch pad it is possible to turn the appliance ON, OFF and control the flame setting.

NOTE: When using the touch pad buttons the red LED will briefly illuminate and a beep will be emitted from the appliance to indicate an accepted command.

To Switch ON:

- 2.50 To turn the appliance ON press the ON/OFF button once. The ignition sequence will commence. This may take up to 20 seconds. The pilot will be lit once the start up sequence has completed.
- 2.51 If the pilot fails to light, press the ON/OFF button again to switch OFF. Wait for at least 30 seconds before attempting to switch on again.

To change the flame level:

- 2.52 With the Pilot lit the appliance is in Standby mode.
- 2.53 Press the button below the symbol (↑) once. The main burner will be ignited on the Low flame setting.
- 2.54 Press the button below the symbol (↑) once more to increase the flame setting to the Medium position.
- 2.55 Press the button below the symbol (↑) once more to increase the flame setting to the High position.
- 2.56 To reduce the flame, press the button below the symbol (↓). At the lowest setting only the Pilot will be lit and the appliance will be in Standby mode.

To Switch OFF:

- 2.57 To turn the appliance OFF press the ON/OFF button. The pilot flame will be extinguished.

NOTE: Following main burner operation do not attempt to switch on the appliance again for at least 3 minutes.

TOUCH PAD CONTROL NOT WORKING

If the appliance is not operating with the touch pad control:

- 2.58 In accordance with Section 4, replace the batteries in the wall switch unit.
- 2.59 If the appliance still fails to operate consult your installer or Gazco dealer.

3. CLEANING THE STUDIO

- 3.1 Make sure the appliance and surrounds are cool before cleaning.
- 3.2 Use:
- A dry cloth or stainless steel product to clean the polished plate.
 - A damp cloth for the painted frame.
 - A damp cloth to clean the granite/enamelled inner panels.
 - Soap and water to clean the glass.

Opening the Glass Window

- 3.3 Steel Frame

If fitted with a Steel Frame, this needs to be removed first:

USER INSTRUCTIONS

- 3.4 Lift the frame upwards off its four support brackets (see Diagram 5).

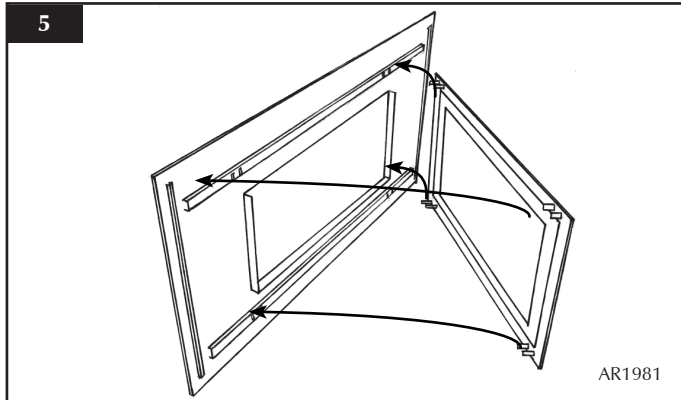

All models

- 3.5 Using the hexagon key provided release the window locks at the top of the glass door (see Diagram 6).
- 3.6 The locks move from shut to open towards the outer edges of the glass door (see Diagram 6).

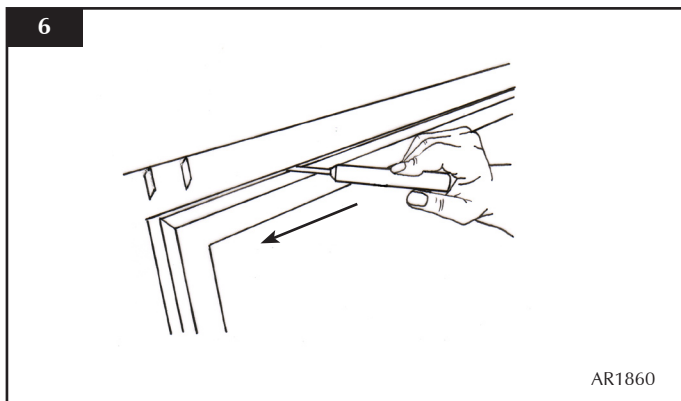

- 3.7 Support the frame and let it fall gently forward.
- 3.8 Open it down to its stop position.
- 3.9 **When closing the window ensure the window catches are fully engaged.**

4. CHANGING THE STUDIO BATTERIES

The appliance batteries are located behind the wall switch plate.

- 4.1 Undo the two screws securing the wall plate and gently bring it forward to expose the wires behind. Keep the wall plate supported, taking care not to put any strain on the wires (see Diagram 7).

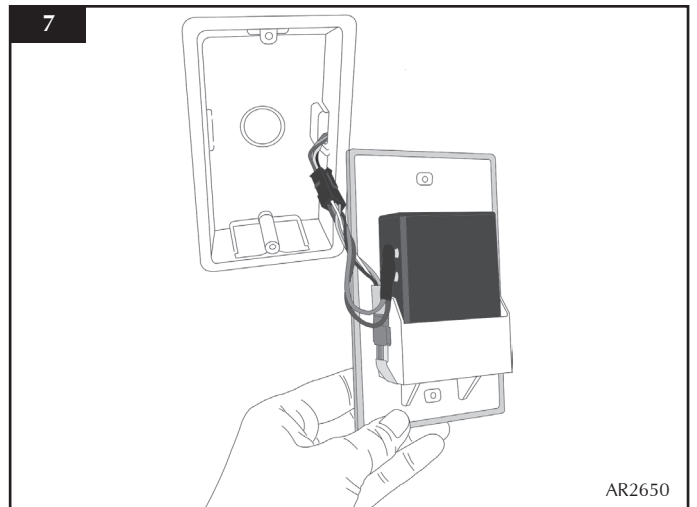

- 4.2 Whilst supporting the wall plate remove the battery holder from its location (see Diagram 8).

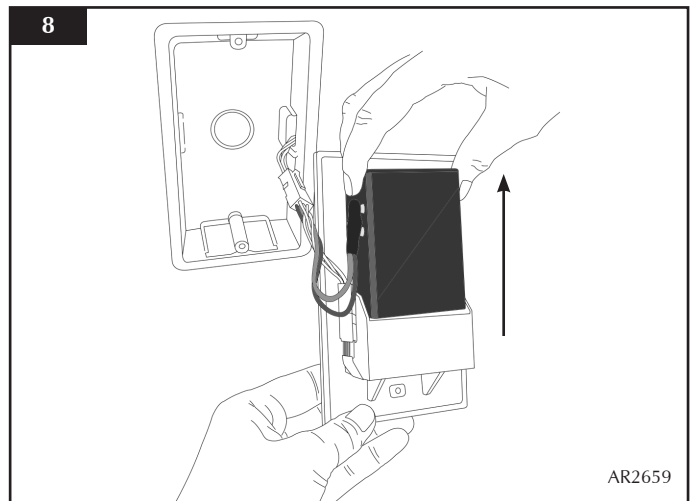

- 4.3 If it is not possible to support the wall plate and battery holder at the same time separate the wall plate from the dry lining box by disconnecting the plug as shown in Diagram 9. Press the top of the clip on the upper section to release.

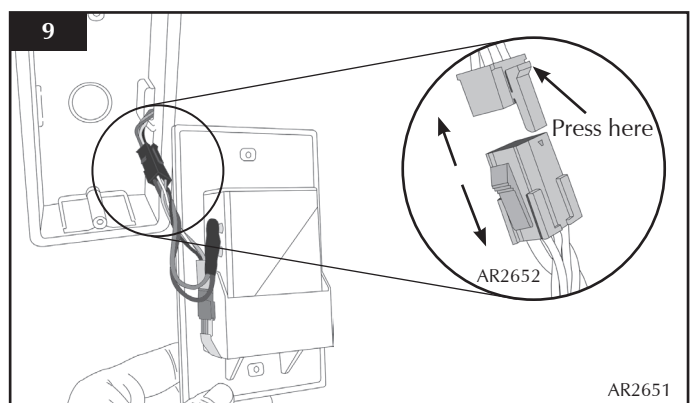

USER INSTRUCTIONS

- 4.4 Flip the battery holder over end to end and remove the cover by sliding off in the direction of the arrow as shown in Diagram 10.

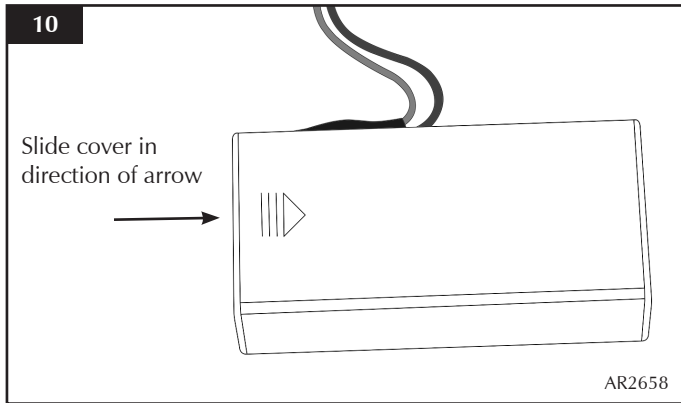

- 4.5 Remove the old batteries and correctly position the three new high quality (Duracell or similar) size C / HR14 batteries into the battery holder (see Diagram 11).

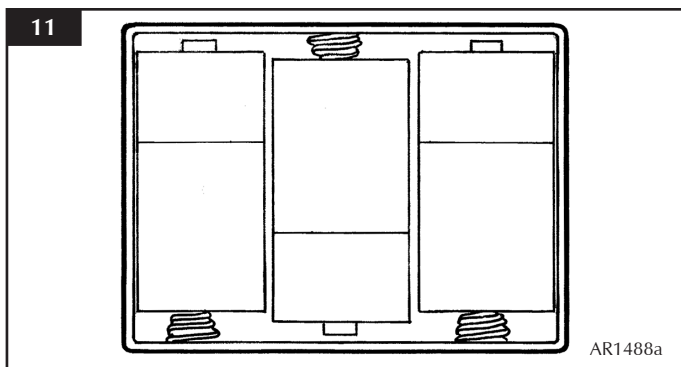

- 4.6 Re-assemble in reverse.

PLEASE ENSURE NO WIRES ARE TRAPPED BEFORE REPLACING THE WALL PLATE. THE TOUCH PAD LEAD IS EASILY DAMAGED.

5. ARRANGEMENT OF FUEL BED

ADVICE ON HANDLING AND DISPOSAL OF FIRE CERAMICS

The fuel effect of the log version in this appliance is made from Refractory Ceramic Fibre (RCF), a material which is commonly used for this application.

Protective clothing is not required when handling these articles, but we recommend you follow normal hygiene rules of not smoking, eating or drinking in the work area and always wash your hands before eating or drinking.

To ensure that the release of RCF fibres are kept to a minimum, during installation and servicing a HEPA filtered vacuum is recommended to remove any dust accumulated in and around the appliance before and after working on it.

When servicing the appliance it is recommended that the replaced items are not broken up, but are sealed within heavy duty polythene bags and labelled as RCF waste. RCF waste is classed as stable, non-reactive hazardous waste and may be disposed of at a licensed landfill site.

Excessive exposure to these materials may cause temporary irritation to eyes, skin and respiratory tract; wash hands thoroughly after handling the material.

- 5.1 **Stone Chippings:** If you need to replace stone chippings and refill the tray, make sure the stone chippings are flattened so they are level with the rim of the tray.
- 5.2 **Vermiculite for Logs Layout:** Use the entire bag of supplied Vermiculite.

TAKE CARE NOT TO SPILL STONE CHIPPINGS OR VERMICULITE INTO THE PILOT AREA. ONLY STONE CHIPPINGS OR VERMICULITE SUPPLIED BY GAZCO CAN BE USED IN THIS APPLIANCE.

USER INSTRUCTIONS

6. LOG LAYOUT

LOGS MUST BE POSITIONED ACCORDING TO THE FOLLOWING INSTRUCTIONS TO GIVE THE CORRECT FLAME EFFECT

- 6.1 Use all the vermiculite to fill the burner tray and spread evenly across the whole burner.
- 6.2 Rest the ceramic bark against the front face of the pilot shield (see Diagram 12).

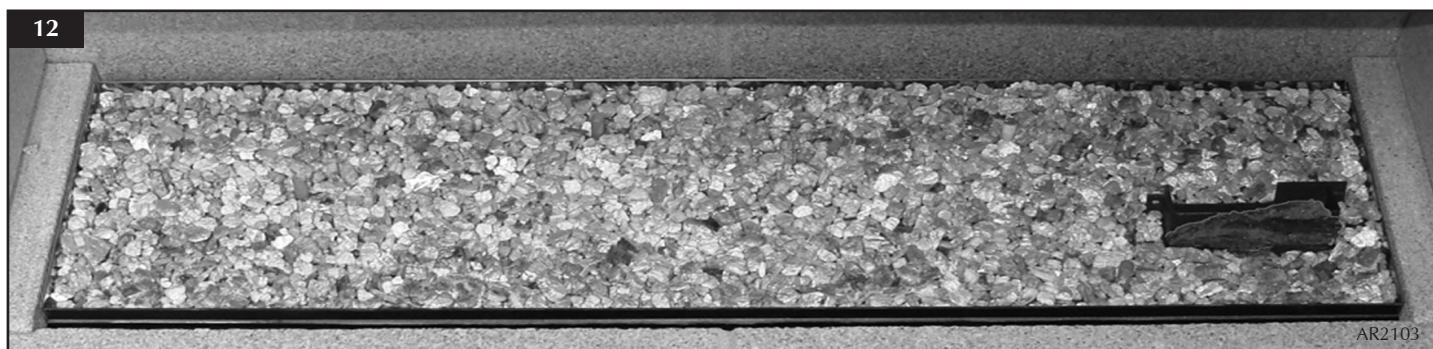

All logs can be identified by a letter (A - H) on their underside. The first three logs, A, B and C, also have holes to locate each onto a burner stud.

- 6.3 Working from left to right place logs A, B and C onto their studs as illustrated in Diagram 13.

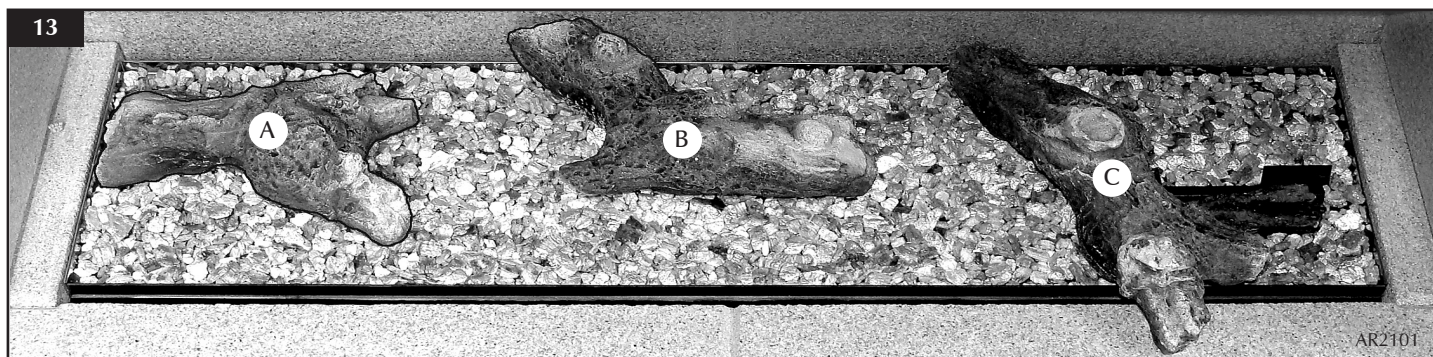
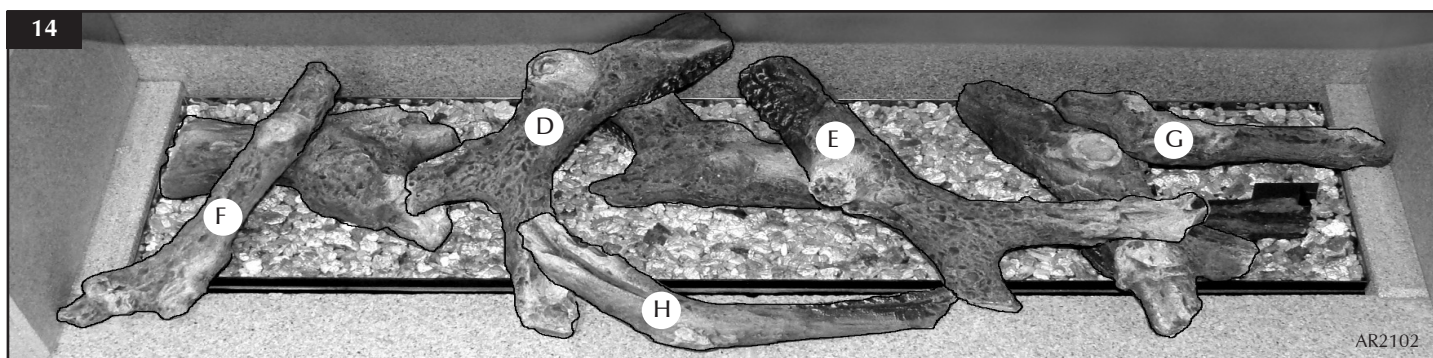

Diagram 14 shows the layout of logs D to H.

- 6.4 Log D has a recess on the underside to fit onto the stud of Log B at the back left. The small branch of the log rests on Log A.
- 6.5 A recess in the back of Log E fits the stud on Log B and its long branch rests snugly behind a wood knot of Log C.



USER INSTRUCTIONS

- 6.6 Log F fits centrally onto Log A with its front edge resting on the front panel.
- 6.7 Log G is centrally positioned around the moulded wood knot of Log C and rests against the right side panel crossing the pilot shield beneath.
- 6.8 The small branch underneath Log H rests on the front panel and overlaps Log D just touching Log E.

LAYOUT FOR STUDIO 2

- 6.9 Preparation with vermiculite and the ceramic bark pilot shield is the same as for Studio 1, see 6.1 & 6.2 above.

All logs can be identified by the letters (A - J) on their underside. The first four logs, I, A, B and C also have holes to locate each onto a burner stud.

- 6.10 Place logs I, A, B and C onto their studs as illustrated in Diagram 15.

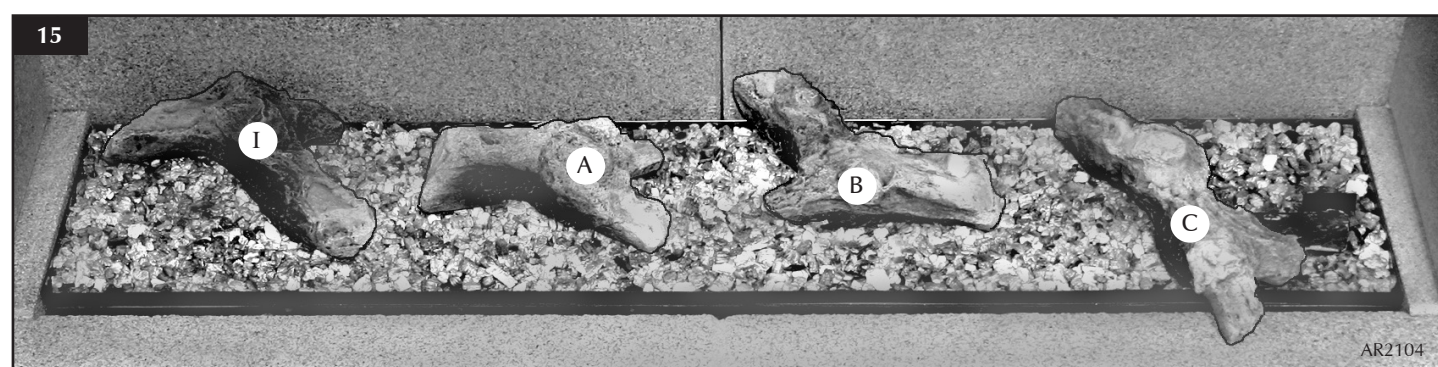
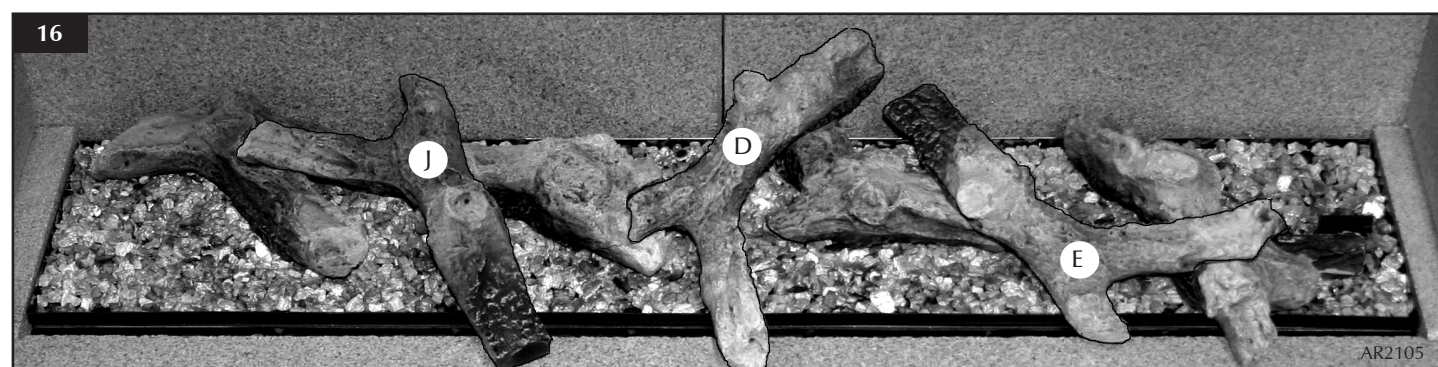

Diagram 16 shows the layout of logs D, E and J.

- 6.11 Log D has a recess on the underside to fit onto the stud of Log B at the back left. The small branch of the log rests on Log A.
- 6.12 A recess in the back of Log E fits the stud on Log B and its long branch rests snugly behind a wood knot of Log C.



- 6.13 The underside of log J has a moulded 'stop'. This rests about 12mm in from the left edge of Log A. The left branch of Log J also rests in the recess in Log I (see Diagram 16 above).

USER INSTRUCTIONS

Diagram 17 shows the layout of the last four logs, F, G and two of log H:

- 6.14 Log F fits centrally onto Log I with its front edge resting on the front panel.
- 6.15 Log G is centrally positioned around the moulded wood knot of Log C and rests against the right side panel crossing the pilot shield beneath.
- 6.16 The first Log H rests on the front panel, overlapping Log D and touching Log E.
- 6.17 The second Log H rests anywhere on the front panel between F and J. **DO NOT LET THIS LOG OVERLAP THE BURNER.**

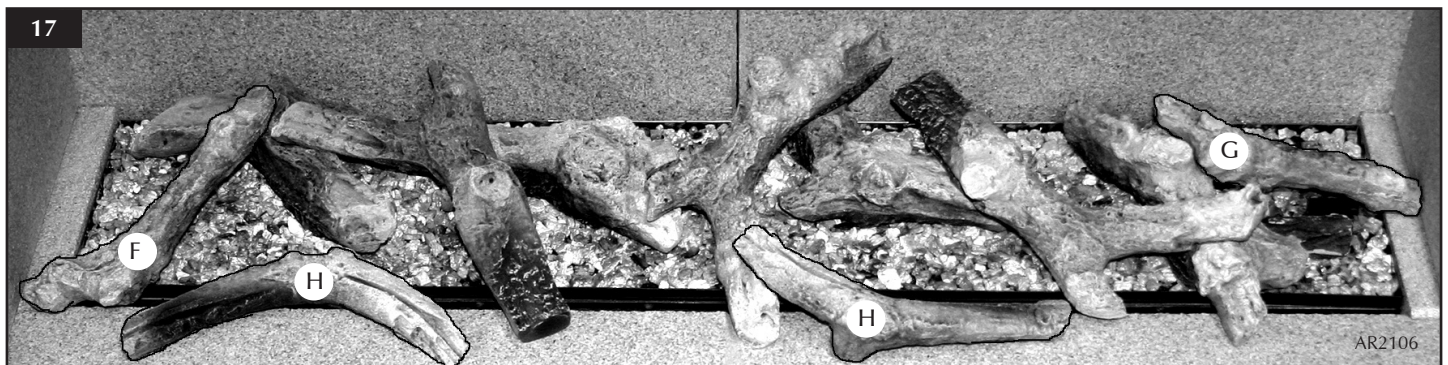

7. FLAME FAILURE DEVICE

- 7.1 This is a safety feature incorporated on this appliance which automatically switches off the gas supply if the pilot goes out and fails to heat the thermocouple.

8. RUNNING IN

- 8.1 The surface coating on the metal used in your GAZCO appliance will "burn off" during the first few hours of use producing a harmless and temporary odour. This will disappear after a short period of use. If the odour persists, ask your installer for advice.
- 8.2 During the first few hours of burning there may be discolouration of the flames. This will also disappear after a short period of use.

9. SERVICING

- 9.1 The appliance must be serviced every 12 months by a qualified Gas Engineer. In all correspondence always quote the Model number and the Serial number which may be found on the data badge.

10. VENTILATION

- 10.1 Any purpose provided ventilation should be checked periodically to ensure that it is free from obstruction.

11. INSTALLATION DETAILS

- 11.1 Your installer should have completed the commissioning sheet at the front of this book. This records the essential installation details of the appliance. In all correspondence always quote the Model number and Serial number.

12. HOT SURFACES

- 12.1 Parts of this appliance become hot during normal use.
- 12.2 Regard all parts of the appliance as a working surface.
- 12.3 Provide a suitable fire guard to protect young children and the infirm.

13. APPLIANCE WILL NOT LIGHT

If you cannot light the Studio:

- 13.1 Check and change the batteries in the remote handset.
- 13.2 Check and change the wall switch batteries (see Section 4).
- 13.3 Consult your Gazco dealer or installer if the Studio still does not light.

INSTALLATION INSTRUCTIONS

TECHNICAL SPECIFICATION

COVERING THE FOLLOWING MODELS:

STUDIO 1
CONVENTIONAL FLUE

STUDIO 2
CONVENTIONAL FLUE

STONE CHIPPINGS VERSION

Model	Gas CAT.	Gas Type	Working Pressure	Aeration	Injector	Gas Rate m ³ /h	Input kW (Gross)		Country
							High	Low	
Studio 1 CF	12H	Natural G20	20mbar	6 x 10	390	0.657	6.9	4.0	GB, IE
Studio 1 CF	13+	Propane G31	37mbar	Open both sides	185	0.257	6.9	4.0	GB, IE
		Butane G30	29mbar			0.197			

Model	Gas CAT.	Gas Type	Working Pressure	Aeration	Injector	Gas Rate m ³ /h	Input kW (Gross)		Country
							High	Low	
Studio 2 CF	12H	Natural G20	20mbar	9 x 15 offset	530	0.791	8.3	4.2	GB, IE
Studio 2 CF	13+	Propane G31	37mbar	One side open + 10 x 16	225	0.312	8.3	4.2	GB, IE
		Butane G30	29mbar	Open both sides		0.238			

Studio 1					Efficiency Class 2 - 70%	NO _x Class 4
Studio 2					Efficiency Class 2 - 78%	NO _x Class 4
Weight	Appliance Only	Profil	Bauhaus	Steel	Flue Size	
					TOP EXIT	REAR EXIT
Studio 1	52 Kg	3.6 Kg	3.6Kg	18.5Kg	127mm ø	178mm ø minimum
Studio 2	60Kg	4.6Kg	4.6Kg	21.8Kg	Gas Inlet Connection Size = 8mm ø	
					Minimum Flue Specification = T260/N2/0/D/1	
					Minimum Flue Temp = 220°C	

INSTALLATION INSTRUCTIONS

TECHNICAL SPECIFICATION

COVERING THE FOLLOWING MODELS:

STUDIO 1
CONVENTIONAL FLUE

STUDIO 2
CONVENTIONAL FLUE

LOG VERSION

Model	Gas CAT.	Gas Type	Working Pressure	Aeration	Injector	Gas Rate m ³ /h	Input kW (Gross)		Country
							High	Low	
Studio 1 CF	12H	Natural G20	20mbar	6 x 10	375	0.638	6.7	4.0	GB, IE
Studio 1 CF	13+	Propane G31	37mbar	6 x 10 16 x 23	128	0.260	6.9	4.0	GB, IE
		Butane G30	29mbar	16 x 23 (2)		0.197			

Model	Gas CAT.	Gas Type	Working Pressure	Aeration	Injector	Gas Rate m ³ /h	Input kW (Gross)		Country
							High	Low	
Studio 2 CF	12H	Natural G20	20mbar	6 x 15	530	0.790	8.5	4.4	GB, IE
Studio 2 CF	13+	Propane G31	37mbar	6 x 8 16 x 23	150	0.331	8.8	4.4	GB, IE
		Butane G30	29mbar	16 x 23 (2)		0.253			

Studio 1					Efficiency Class 2 - 70%	NO _x Class 4
Studio 2					Efficiency Class 2 - 78%	NO _x Class 4
Weight	Appliance Only	Profil	Bauhaus	Steel	Flue Size	
					TOP EXIT	REAR EXIT
Studio 1	52 kg	3.6 kg	3.6 kg	18.5 kg	127mm ø	178mm ø minimum
Studio 2	60 kg	4.6 kg	4.6 kg	21.8 kg	Gas Inlet Connection Size = 8mm ø	
					Minimum Flue Specification = T260/N2/0/D/1	
					Maximum Flue Temp = 220°C	

INSTALLATION INSTRUCTIONS

TECHNICAL SPECIFICATION

This appliance has been certified for use in countries other than those stated. To install this appliance in these countries, it is essential to obtain the translated instructions and in some cases the appliance will require modification. Contact Gazco for further information.

PACKING CHECKLIST

Qty Description	Fixing Kit containing:
For Stone Chippings Layout 1 x White Stone Chippings	1 x Instruction Manual 4 x Wood Screws 4 x Wall Plugs 1 x Handset 2 x AA 1.5 alkaline batteries 3 x Size C / HR14 batteries 1 x Wall box 1 x Wall plate/touch pad 1 x Battery holder 1 x Foam seal
For Log Layout 1 x Log Set 1 x Vermiculite	

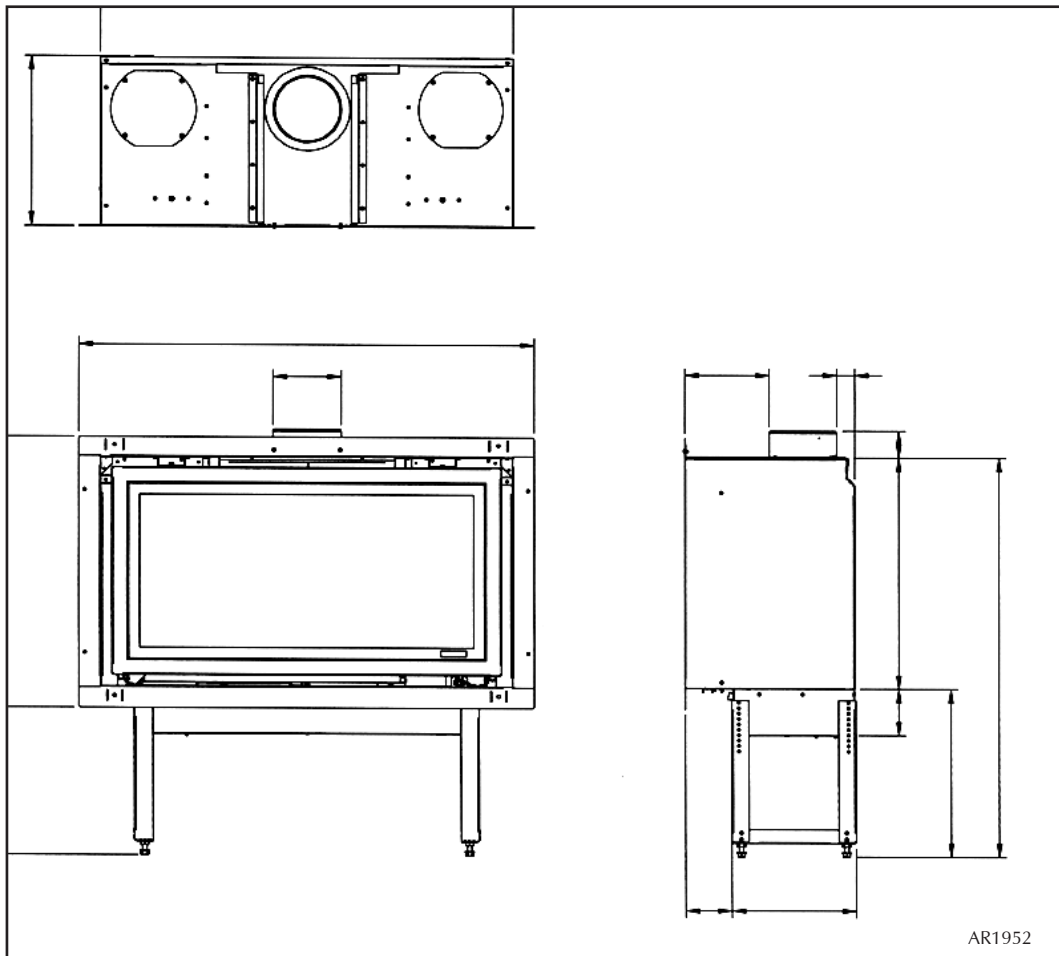

INSTALLATION INSTRUCTIONS

TECHNICAL SPECIFICATION

STEEL FRAME DIMENSIONS		
Dimension	Studio 1	Studio 2
A	1120	1350
B	675	675
C	646	846
D	320	320
E	177	177
F	237	237
G	25	25

PROFIL FRAME DIMENSIONS		
Dimension	Studio 1	Studio 2
A	846	1046
B	520	520
C	750	950
D	424	424
E	48	48
F	48	48
G	12.5	12.5

BAUHAUS FRAME DIMENSIONS		
Dimension	Studio 1	Studio 2
A	860	1060
B	534	534
C	750	950
D	424	424
E	55	55
F	55	55
G	28	28

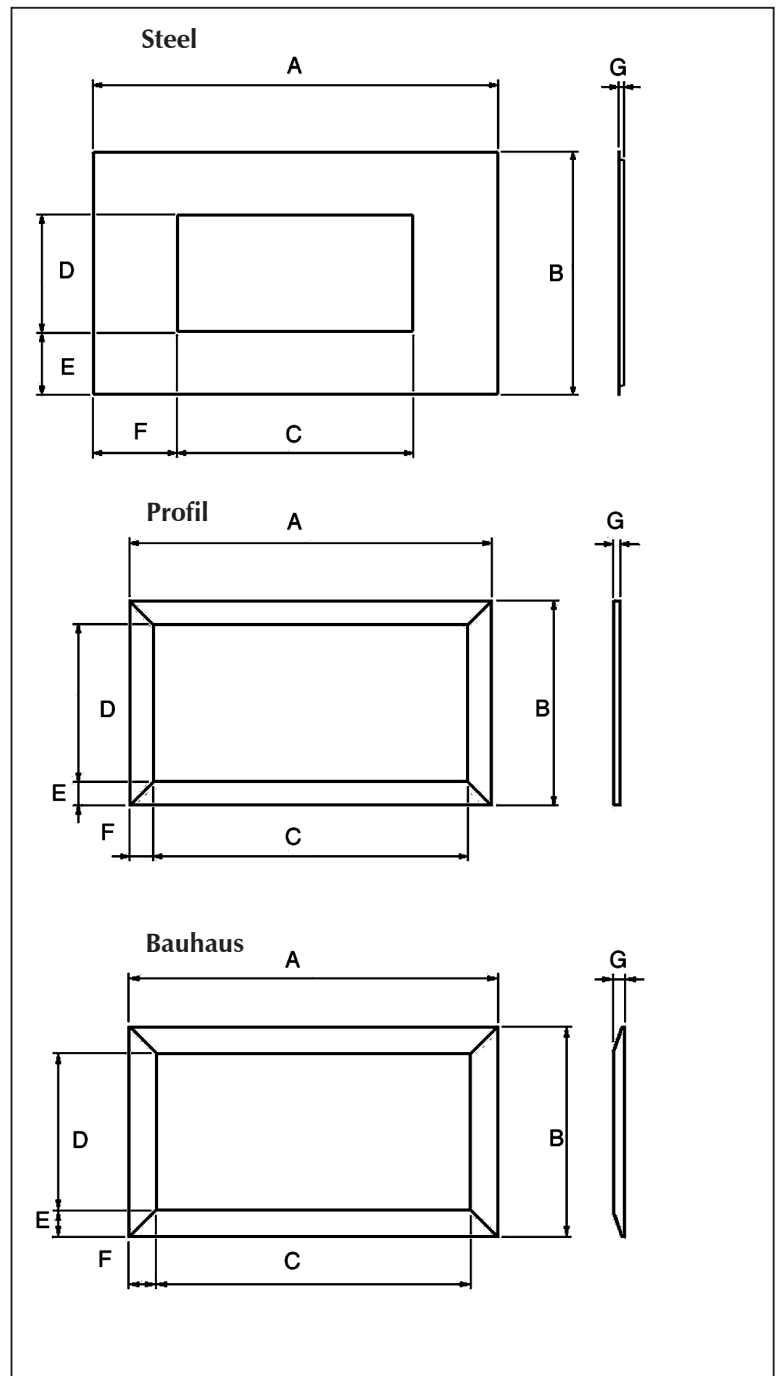

INSTALLATION INSTRUCTIONS

SITE REQUIREMENTS

1. FLUE AND CHIMNEY REQUIREMENTS

WHEN INSTALLING A FLUE SYSTEM PLEASE REFER TO THE MANUFACTURER'S INSTRUCTIONS.

The European chimney standards now describe chimneys and flues by their temperature, pressure and resistance to corrosion, condensation and fire. To identify the correct flue system, the minimum flue specification is shown in the *Technical Specification*. Existing chimneys are not covered by this system.

The flue must be installed in accordance with all local and national regulations and the current rules in force:

- 1.1. A flexible liner must be continuous from the appliance spigot to the roof terminal.
- 1.2. The minimum effective height of the flue must be 3m (10').
- 1.3. The flue must be free from any obstruction.
- 1.4. Any damper plates must be removed or secured in the fully open position and no restrictor plates fitted.
- 1.5. The chimney should be swept immediately before installing the appliance, but it need not be swept if you can see the chimney is clean and free from obstruction throughout.

2. FLUE OPTIONS

There are three suitable Conventional Flues:

- Stud work is Top Exit only - Twin Wall Rigid
127mm (5")
- Top Exit - Builder's Opening Lined
127mm (5")
- Rear Exit - Builder's Opening Unlined
178mm (7") minimum

3. GAS SUPPLY

THIS APPLIANCE IS INTENDED FOR USE ON A GAS INSTALLATION WITH A GOVERNED METER.

- 3.1. Make sure local distribution conditions (identification of the type of gas and pressure) and the adjustment of the appliance are compatible before installation.
- 3.2. Ensure the gas supply delivers the required amount of gas and is in accordance with the rules in force.
- 3.3. You can use soft copper tubing on the installation and soft soldered joints outside the appliance and below the firebed.

- 3.4. A factory fitted isolation device is part of the inlet connection; no further isolation device is required.
- 3.5. All supply gas pipes must be purged of any debris that may have entered prior to connection to the appliance.
- 3.6. The gas supply enters through the silicone panel located on the LEFT-HAND side of the outer box. Slit with a sharp knife prior to passing the supply pipe through.
- 3.7. The gas supply must be installed in a way that does not restrict the removal of the appliance for servicing and inspection.

4. VENTILATION

IMPORTANT: Ensure any national ventilation requirements are taken into account during installation of the appliance.

UK ONLY:

The Studio 1 has a nominal input not exceeding 7.0kW and does not normally require any additional permanent ventilation.

The Studio 2 must have permanent ventilation with a minimum open area of 5.85cm².

FOR THE REPUBLIC OF IRELAND REFER TO THE RULES IN FORCE FOR VENTILATION REQUIREMENTS.

5. APPLIANCE LOCATION

NOTE: It is recommended you construct the back panel of the fireplace from natural materials cut into three or more sections to prevent cracking. Resin-based materials may not be suitable. This appliance is an effective heat producer and attention must be paid to the construction and finish of the fireplace.

- 5.1. When preparing the aperture for installation into a builder's opening, the front of the wall must be cut out down to the level on which the appliance is to stand. Then, to obtain the correct dimensions shown in Diagram 1a, the lower section of wall must be reconstructed as shown in Diagram 1a.

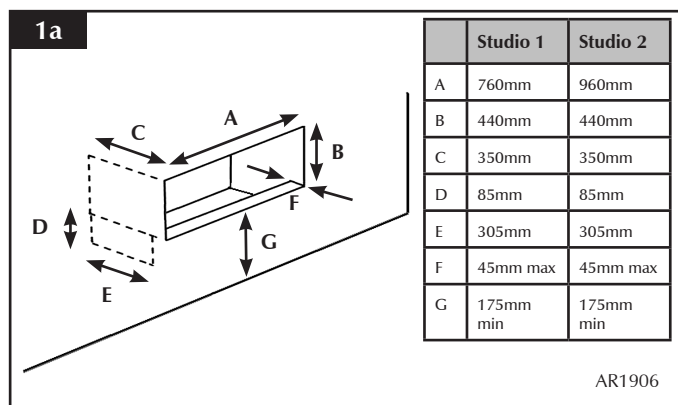

INSTALLATION INSTRUCTIONS

SITE REQUIREMENTS

- 5.2 This appliance must stand on a non-combustible base that is at least 12mm thick; the minimum opening dimensions are shown in Diagram 1a.
- 5.3 When the appliance is installed in a masonry chimney without a liner, there must be a minimum debris collection area (see Diagram 1b).

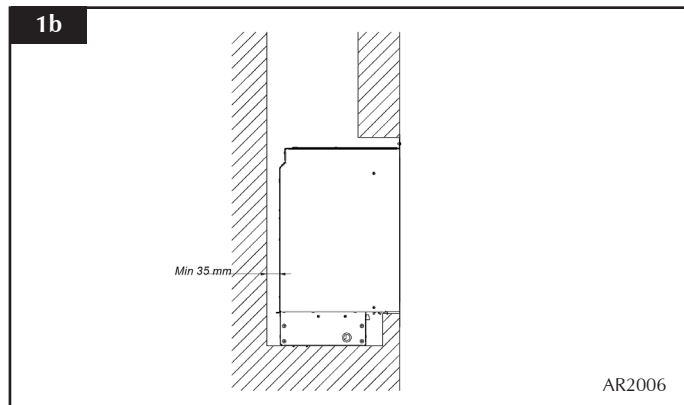

- 5.4 **DO NOT** install onto a combustible wall; all combustible materials must be removed from the area shown in Diagram 1c.

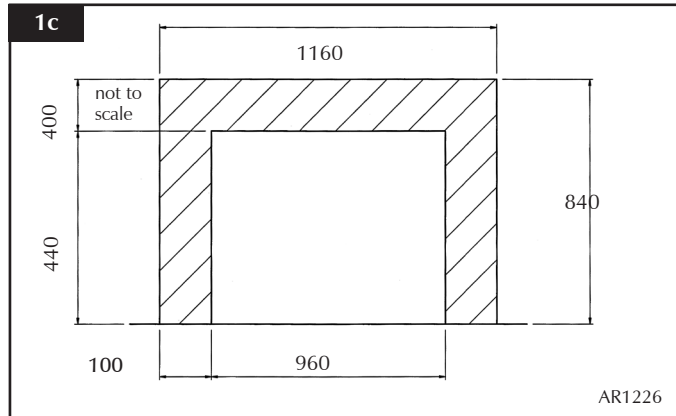

- 5.5 A combustible shelf must be a minimum of 400mm above the top of the appliance. This is based on a 150mm deep shelf. For every extra 13mm of depth add 25mm above the 400mm from the top of the appliance, not the frame.
- 5.6 A side wall must be a minimum of 300mm from the side of the appliance, not the frame.

INSTALLATION INSTRUCTIONS

INSTALLATION

IMPORTANT: REFER TO DATA BADGE AND TECHNICAL SPECIFICATION AT THE FRONT OF THE MANUAL TO ENSURE THE APPLIANCE IS CORRECTLY ADJUSTED FOR THE GAS TYPE AND CATEGORY APPLIED IN THE COUNTRY OF USE.
FOR DETAILS OF CHANGING BETWEEN GAS TYPES REFER TO SERVICING, SECTION 10, REPLACING PARTS.

1. SAFETY PRECAUTIONS

- 1.1 For your own and other's safety, you must install this appliance according to local and national codes of practice. Failure to install the stove correctly could lead to prosecution.
- 1.2 Read these instructions before installing and using this stove.
- 1.3 These instructions must be left intact with the user.
- 1.4 Do not attempt to burn rubbish on this appliance.
- 1.5 Keep all plastic bags away from young children.
- 1.6 Do not place any object on or near to the appliance and allow adequate clearance above the appliance.

IF THE APPLIANCE IS EXTINGUISHED OR GOES OUT DURING USE, WAIT 3 MINUTES BEFORE ATTEMPTING TO RELIGHT THE APPLIANCE.

2. INSTALLATION OF THE APPLIANCE

THERE IS AN OPTIONAL DUCT KIT, CODE No. 8572, WHICH CAN BE FITTED AT THE SAME TIME AS THE APPLIANCE INSTALLATION.

- 2.1 This appliance can be installed in four different ways:

- 1) Builder's opening with a frame
- 2) Builder's opening without a frame
- 3) Stud work with a frame
- 4) Stud work without a frame

Where no frame is used an edge kit is available to enable the installer to plaster to a finished edge: Kit No. 8727 CFFK01 for Studio 1 and 8727 CFFK02 for Studio 2 Options 1) and 2) above can be:

- Top exit with a liner
- Rear exit without a liner

- 2.2 The Studio is supplied with a flue fixing plate to attach the flue to the appliance within the aperture (see Diagram 1).

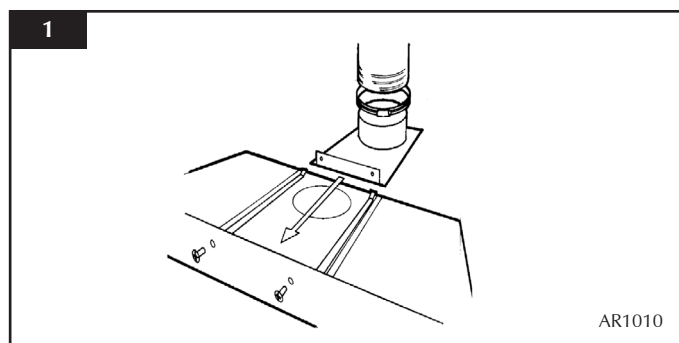

- 2.3 When installing the appliance into a masonry chimney without a liner, it must be converted to a rear exit.
- 2.4 Remove the two fixing screws securing the spigot assembly.
- 2.5 Slide the blanking plate into the guides.
- 2.6 Replace the two fixing screws (see Diagram 2).

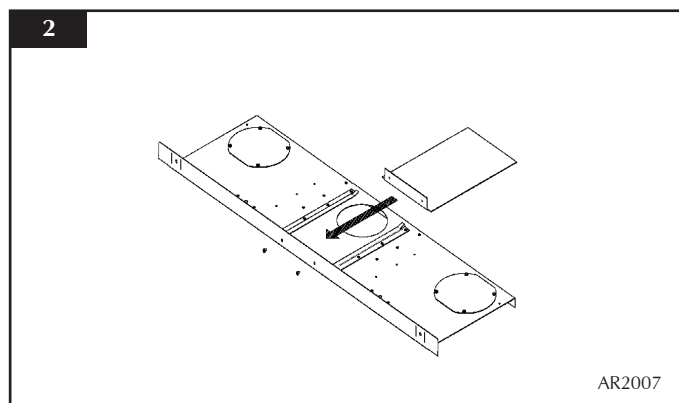

The flue must be in good condition and clear products of combustion (see Installation Instructions, Commissioning).

Options 3) and 4) (Studwork with or without a frame) must be fitted using the top exit only with rigid twin wall flue pipe.

- 2.7 **THE APPLIANCE IS SUPPLIED WITH A WALL BOX CONTAINING THE BATTERIES AND TOUCH PAD. THIS MUST BE RECESSED INTO THE WALL WITH ACCESS FOR THE CABLES PRIOR TO FITTING THE APPLIANCE.**
- 2.8 Remove the appliance from the carton and discard all unnecessary packaging. Ensure no components are thrown away when unpacking.
- 2.9 To access the controls and gas inlet remove the glass door, liners, burner and splitter plate, referring to Servicing Instructions, Replacing Parts.
- 2.10 The gas supply enters the appliance through a silicon panel on the floor under the access panel (see Diagram 3).

INSTALLATION INSTRUCTIONS

INSTALLATION

- 2.11 Slit with a sharp knife before bringing through the supply pipe (see Diagram 3).

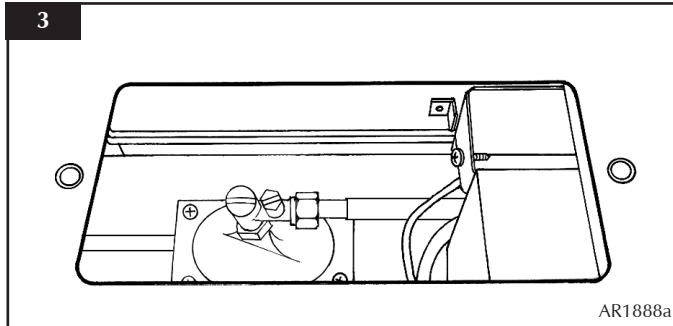

3. STUD WORK INSTALLATION

THERE ARE THREE TYPES OF INSTALLATION INTO STUDWORK DESCRIBED IN THE FOLLOWING PAGES:

- 1) FOR STUDIO WITH EITHER THE STEEL, PROFIL OR BAUHAUS FRAME (SEE SECTION 4).
- 2) FOR AN INSTALLATION WHERE THE STUDIO SITS FLUSH TO THE FINISHED 'EDGE' OF THE WALL (SEE SECTION 5).
- 3) FOR A FURTHER 'EDGE' INSTALLATION PROVIDING A COOL WALL ABOVE THE APPLIANCE TO ALLOW CUSTOMERS TO HANG PICTURES ETC. SEE SECTION 6.

THERE IS A FURTHER DESCRIPTION OF A MASONRY INSTALLATION.

3.1 DISTANCE TO COMBUSTIBLE MATERIAL

COMBUSTIBLE PARTS OF THE STUDWORK MUST BE KEPT BEYOND THE MINIMUM DIMENSIONS SHOWN IN DIAGRAM 4. EVEN IF THE FRAMEWORK IS PROTECTED BY NON-COMBUSTIBLE MATERIAL, YOU MUST MAINTAIN THESE DIMENSIONS (SEE DIAGRAM 4).

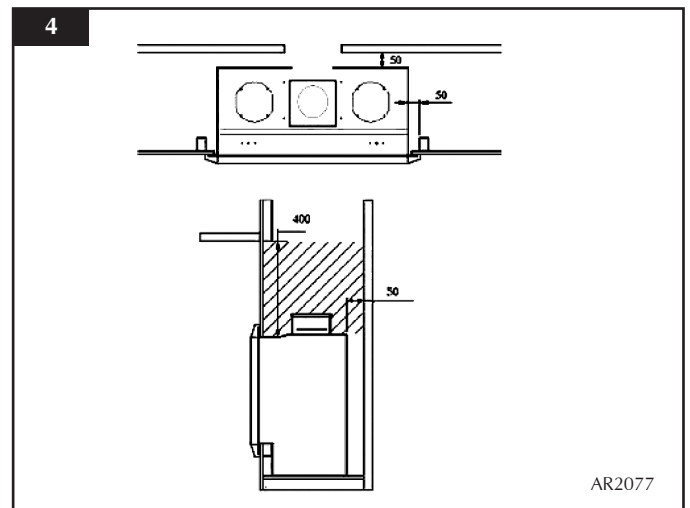

- 3.2 DO NOT PACK THE VOID AROUND OR ABOVE THE APPLIANCE WITH INSULATION MATERIALS SUCH AS MINERAL WOOL.
- 3.3 THE VOID BUILT FOR THE CASSETTE MUST BE VENTILATED TO PREVENT A BUILD-UP OF HEAT. IF THE VOID IS SEALED, THEN YOU MUST FIT VENTS AT BOTH LOW AND HIGH LEVELS OF APPROXIMATELY 50CM² EACH. THESE VENTS MUST TAKE COLD AIR FROM THE ROOM AND RETURN WARM AIR BACK INTO THE ROOM.
- 3.4 AN ACCESS HATCH MUST BE LEFT IN THE SIDE OF THE CHIMNEY BREAST FOR FUTURE SERVICING AND INSPECTION OF THE FLUE AND APPLIANCE.

INSTALLATION INSTRUCTIONS

INSTALLATION

4. STUDWORK INSTALLATION FOR STUDIO WITH FRAMES

NOTE: With the legs fitted, this appliance can stand directly on the floor (normally in a false chimney breast) or without the legs on a protected platform at the required height (see Diagram 5).

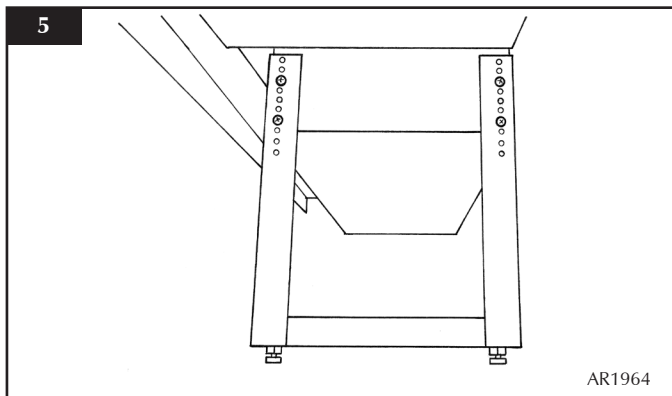

- 4.1 Build the studwork chimney breast and enclosures to the desired size to include the protected platform at the required height.
- 4.2 Line the aperture for the appliance with 12mm thick non-combustible material as shown (see Diagram 6).

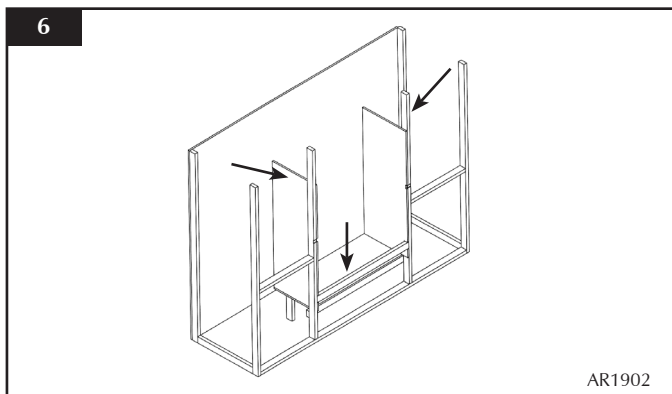

- 4.3 Ensure the clearances are maintained (see Diagram 4).
- 4.4 Site the appliance and decide on flue requirements.
- 4.5 Cut a hole for the flue exit.
- 4.6 Provide gas and electric services into the cassette void on the left-hand side.

Because no combustible material can be used above the appliance, we provide a support bar.

- 4.7 Mark out the position to fit the supplied top support bar into the studwork at the correct height. This bar needs to be recessed into the studwork (see Diagram 7).

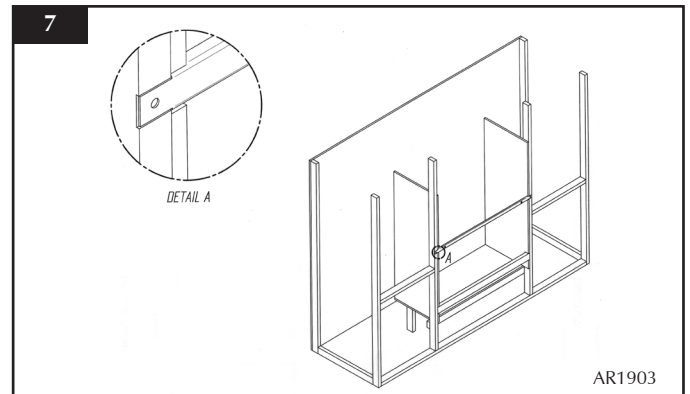

- 4.8 Fit the support bar into the studwork at the correct height (see Diagram 8).

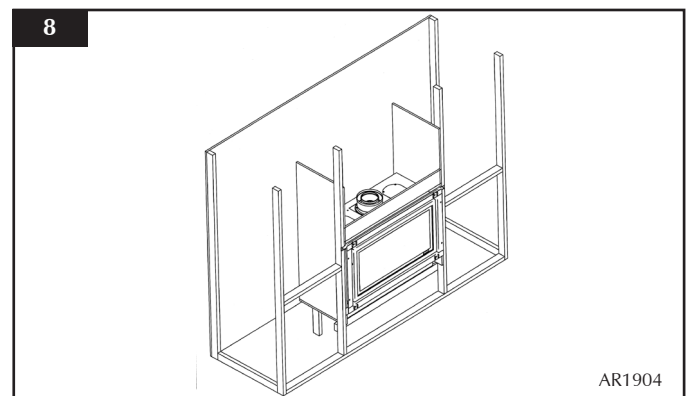

- 4.9 Attach the 4 frame fixing brackets to the appliance (see Diagram 9).

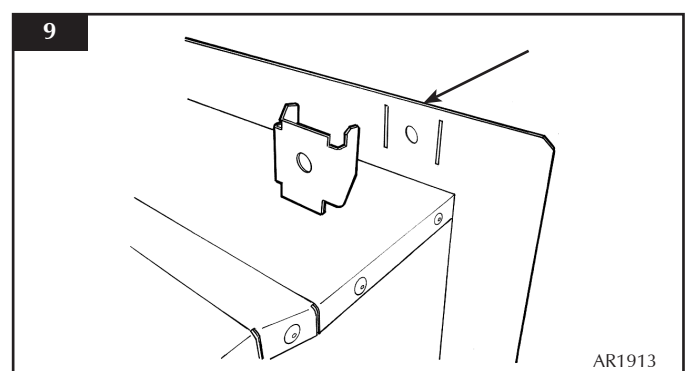

- 4.10 Fix foam seal to the outer flange of the appliance.
- 4.11 Position the appliance.
- 4.12 Fit non-combustible board to the studwork around the appliance. This should extend a minimum of 400mm above the appliance and at least 50mm to the sides of the appliance (from the outer box, not the flanges).

INSTALLATION INSTRUCTIONS

INSTALLATION

- 4.13 Apply plasterboard to the remainder of the studwork.
- 4.14 Secure the appliance back to the studwork using four screws through flange, bracket, support bar.
- 4.15 Apply a plaster finish to the front of the chimney breast.

Slips

Because of the high temperatures this appliance achieves, it is advisable to use marble slips or similar material between the appliance and the plasterboard.

Never use a one-piece slip as expansion (even cracking) can occur.

Note: If a slip is used, longer screws are needed to secure the appliance.

To finish this installation:

- 4.16 Connect the wall box and batteries following instruction in Section 8.
- 4.17 Connect the flue system.
- 4.18 Connect the gas services using the opening in the side of the chimney breast for access.

After commissioning:

- 4.19 Finish the sides of the chimney breast (see Diagram 10).

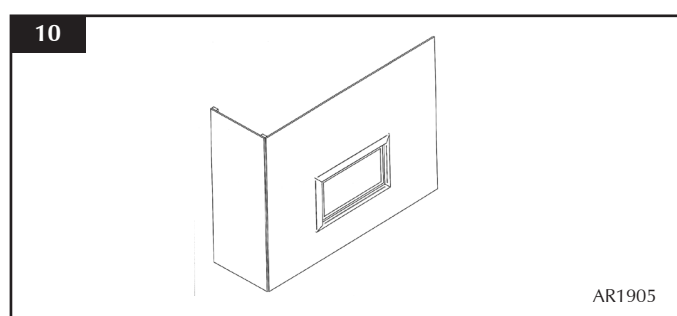

5. STUDWORK FOR STUDIO EDGE INSTALLATION KIT

There is an optional Studio Edge Installation Kit available for installing the appliance without a frame: Studio 1 CF Code No. 8727CFEK01 or Studio 2 CF Code No. 8727CFEK02.

Using the installation kit:

- 5.1 Fit the four metal brackets of the kit to the appliance (see Diagram 11).

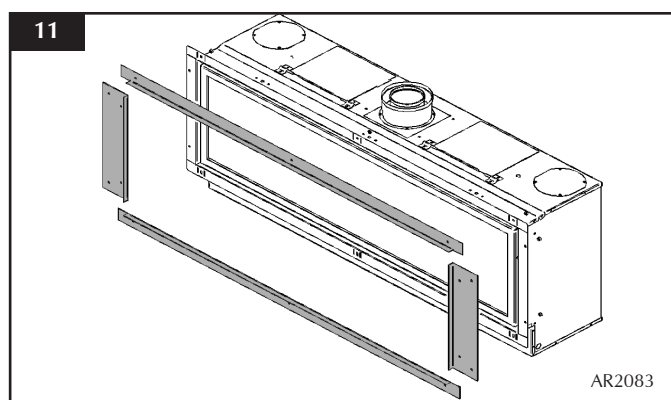

- 5.2 Put vertical studwork at minimum clearance to the side of the appliance (50mm).
- 5.3 Secure to the vertical studwork through the holes in the metal brackets fitted to the appliance.
- 5.4 The kit has been designed so that non-combustible board can be taken right up to the edge of the four brackets (see Diagrams 12 & 13).

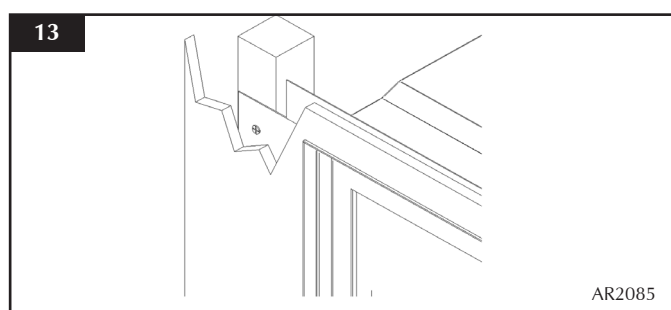
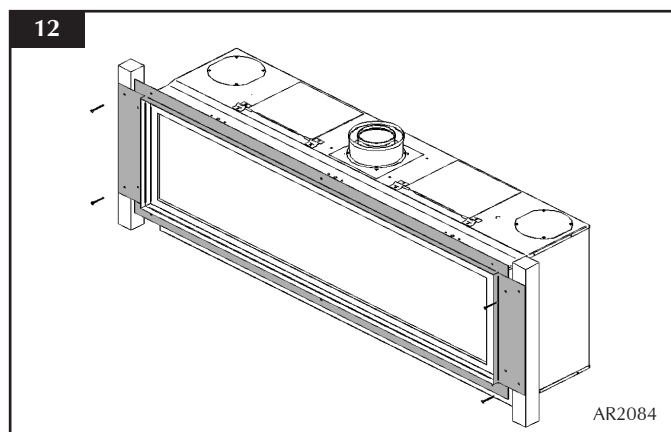

- 5.5 Build the studwork chimney breast to the desired size.
- 5.6 Ensure all clearances to combustible material are maintained (see Section 3 above).
- 5.7 Decide on flue requirements.
- 5.8 Cut a hole for the flue exit.

INSTALLATION INSTRUCTIONS

INSTALLATION

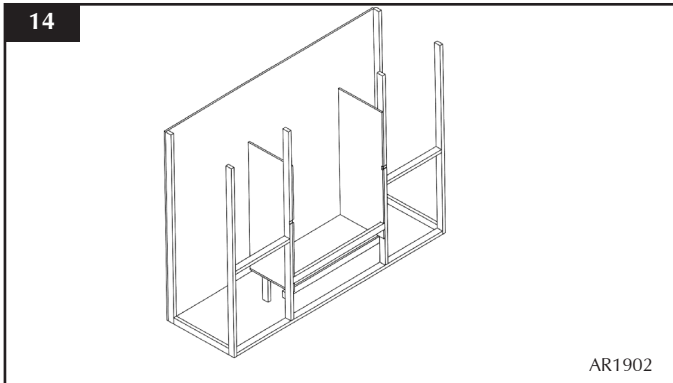

- 5.9 Fit non-combustible board to the studwork above the appliance. This should extend a minimum of 400mm above the appliance.
- 5.10 Fit plasterboard to the remaining chimney breast front.
- 5.11 Connect the flue system and gas services using the opening in the side of the chimney breast for access.
- 5.12 After commissioning, finish the sides of the chimney breast (see Diagram 15).

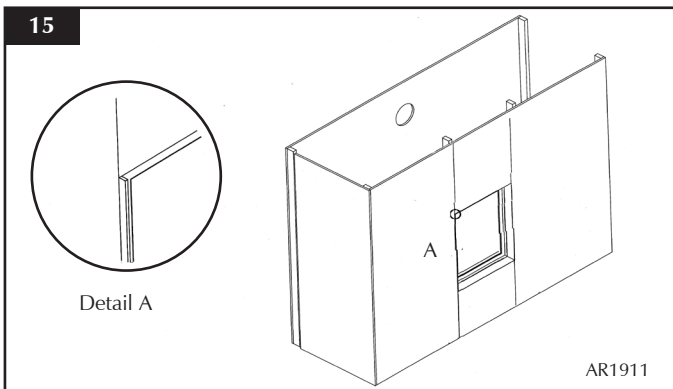

- 5.13 Apply a plaster finish to the chimney breast using heat resistant plaster in the area directly above the appliance.

6. STUDWORK FOR COOL WALL INSTALLATION KIT

For this cool-wall installation, the convected heat from the appliance is channelled into the chimney cavity and vented at the top.

The cool wall installation kit is provided unfinished. This allows the kit to be finished to match the front face decor.

There is an optional Studio Cool Wall Installation Kit available for installing the appliance without a frame: Studio 1 CF Code No. 8727CFCW01 or Studio 2 BF Code No. 8727CFCW02.

Using the fixing kit:

- 6.1 Fit the four metal brackets of the kit to the appliance, Diagram 16. There is a deliberate gap at the top for convected heat.

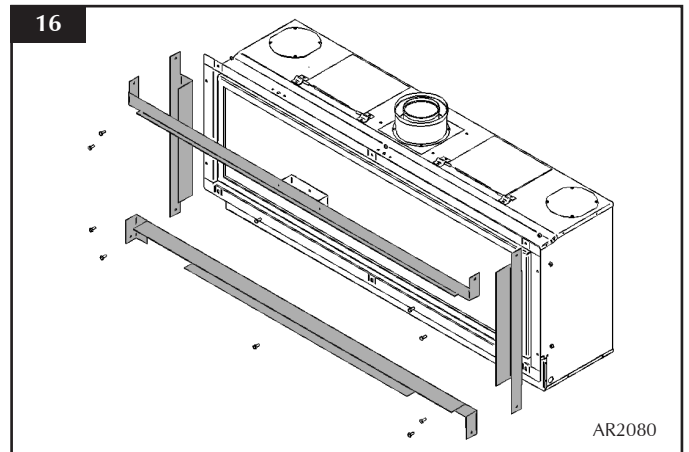

- 6.2 This now determines the width of your two vertical studwork supports. The kit has been designed so that non-combustible board can be taken right up to the edge of the four brackets (see Diagrams 17 & 18).

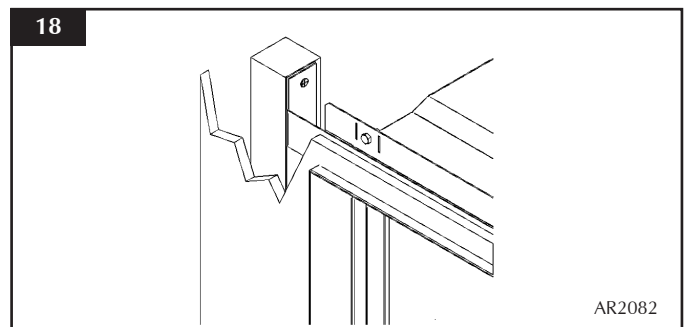
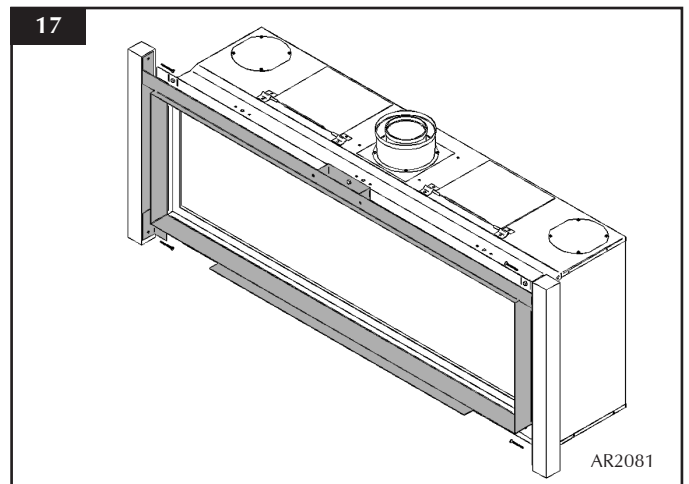

- 6.3 Fix the left and right metal brackets into the studwork.

INSTALLATION INSTRUCTIONS

INSTALLATION

- 6.4 Build the studwork chimney breast to the desired size.
- 6.5 Ensure all clearances to combustible material are maintained (see Section 3 above).
- 6.6 Decide on flue requirements.
- 6.7 Cut a hole for the flue exit.

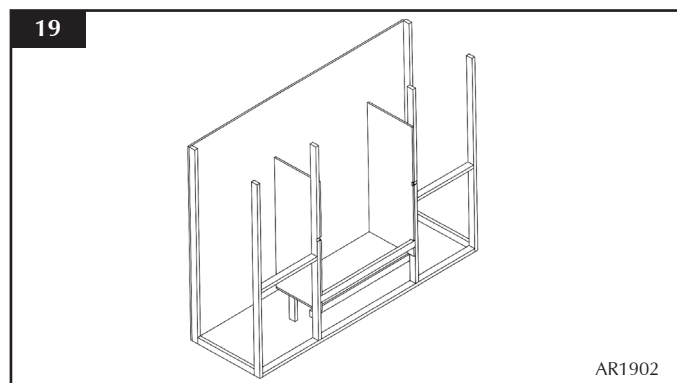

- 6.8 Fit non-combustible board to the studwork above the appliance. This should extend a minimum of 400mm above the appliance.
- 6.9 Fit plasterboard to the remaining chimney breast front.
- 6.10 Connect the flue system and gas services using the opening in the side of the chimney breast for access. After commissioning, finish the sides of the chimney breast (see Diagram 20).

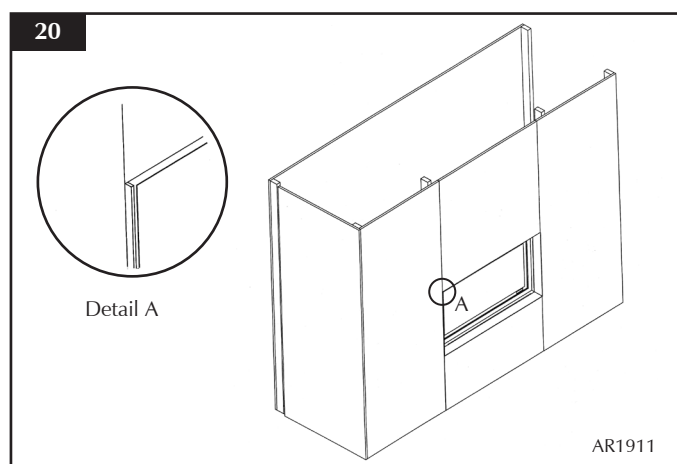

- 6.11 The top of the chimney breast must have a minimum 200cm² vent.
- 6.12 Apply a plaster finish to the chimney breast.

7. MASONRY CHIMNEY INSTALLATION

NOTE: Do not use the legs (of the appliance) in this installation

To remove the glass door:

- 7.1 Use the hexagon key provided to release the two window locks by moving them from shut to open towards the outer edge of the door (see Diagram 21).

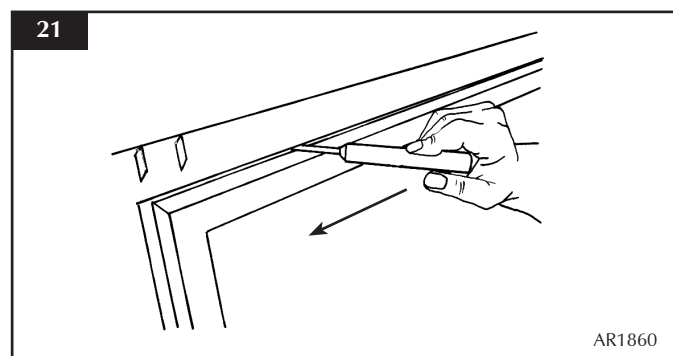

- 7.2 With the door lowered remove the spring clip from the right-hand hinge pin (see Diagram 22).

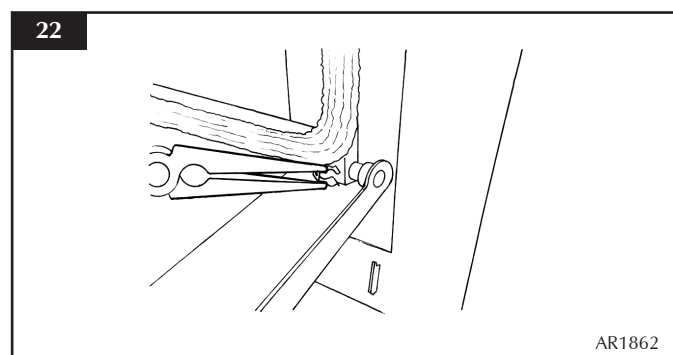

- 7.3 Raise the door to almost upright and move the door to the left. This releases the left-hand side off its hinge pin.
- 7.4 Lower the left-hand side of the door to clear the pin and move the door to the right to release it from the right pin. The door is now free to remove (see Diagram 23).

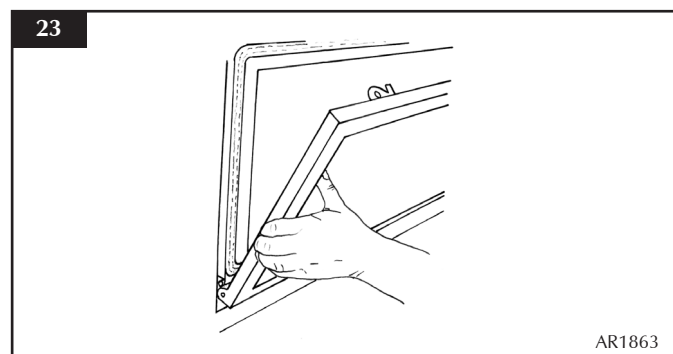

INSTALLATION INSTRUCTIONS

INSTALLATION

- 7.5 Remove all the enamelled panels (see Replacing Parts, Section 5 and Diagram 24 below).

or

- 7.6 Remove all vermiculite panels (see Replacing Parts, Section 6).

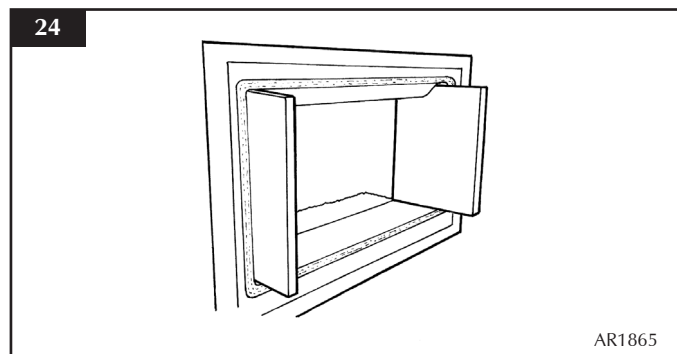

- 7.7 Remove the screw retaining the burner.
- 7.8 Move the burner to the left to disengage the burner flange from the slot and injector.
- 7.9 Raise the right side and remove the burner (see Diagram 25).

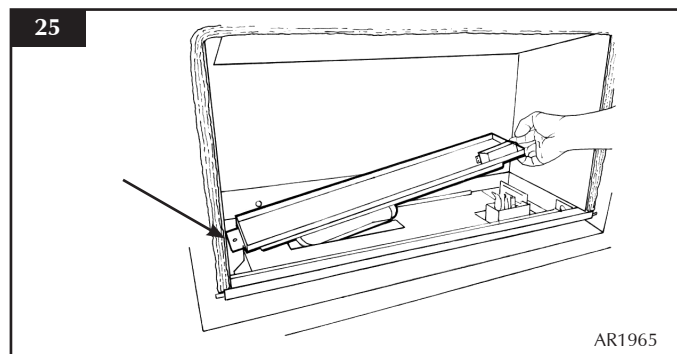

- 7.10 Loosen the two screws retaining the plate beneath the burner.
- 7.11 The front of the plate can now be lifted off the screws. Pull it forward and remove (see Diagram 26).

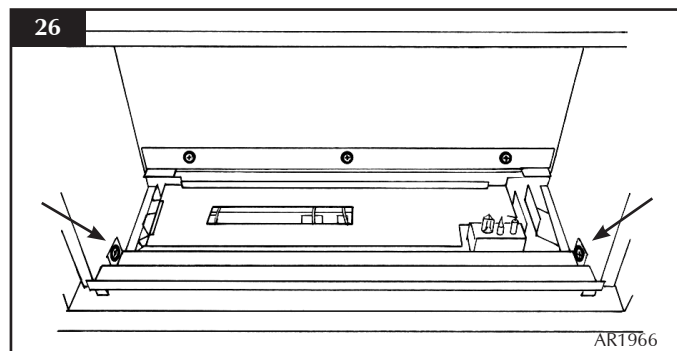

- 7.12 Remove the three screws retaining the rear back panel.

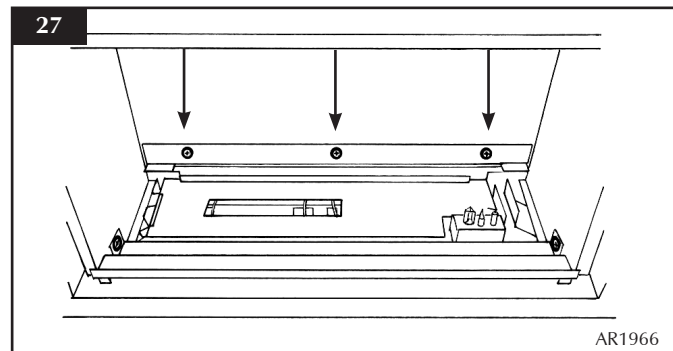

- 7.13 Lift and pull forward off the slotted brackets.
- 7.14 With the appliance on its back remove the three wing nuts and screws retaining the loose box (see Diagram 28).

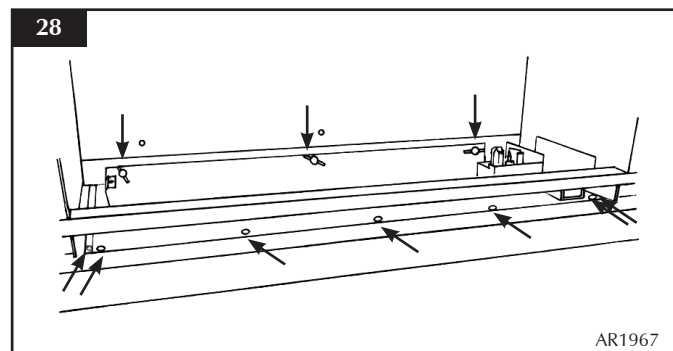

- 7.15 Move the box forward to release the rear off the studs.
- 7.16 Tilt the front edge of the box upwards and remove from the appliance.

METHOD 1 - FRAME

- 7.17 Fit the four frame fixing brackets through the rear of the flanges.
- 7.18 Attach the foam seal around the rear of the flange/
- 7.19 Fit the main firebox into the aperture and secure with the screws and expansion plugs provided through the top and bottom flanges (see Diagram 29).

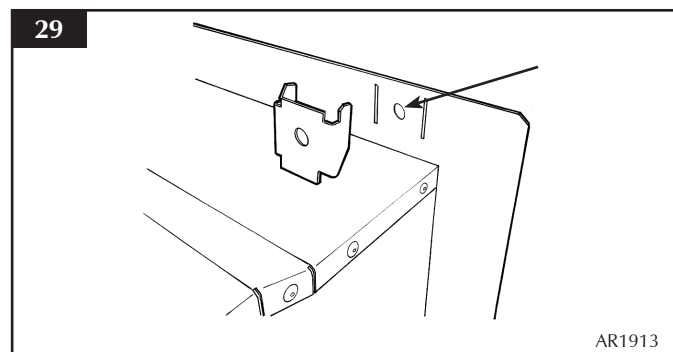

INSTALLATION INSTRUCTIONS

INSTALLATION

- 7.20 Feed the wires for the remote touch pad through the grommet in the left side of the loose box.
- 7.21 The wires are then fed inside the firebox and routed through the available access.
- 7.22 Replace the loose box inside the main firebox ensuring the wires are not trapped.
- 7.23 Replace the three wing nuts and seven screws.
- 7.24 Connect the gas supply and check for leaks.
- 7.25 Replace the rear panel ensuring the bottom edge locates in the tapered brackets (see Diagram 30).

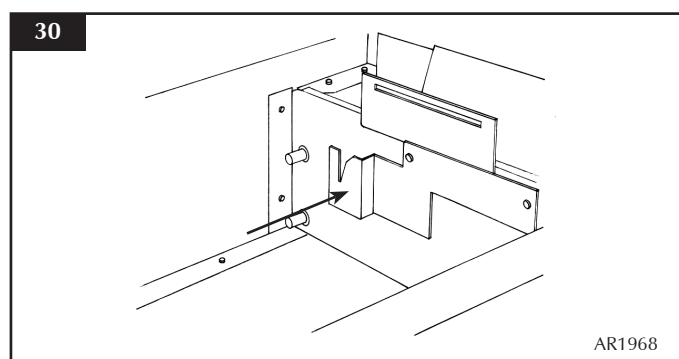

NOTE: To check gas pressure refer to Section 7.48 onward.

- 7.26 Replace the splitter plate.
- 7.27 Locate the rear two tabs into the rear panel.
- 7.28 Engage the two side slots over the screws and secure (see Diagram 31).

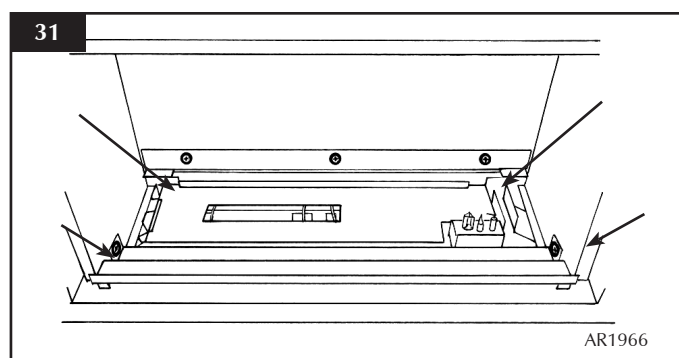

To replace the burner:

- 7.29 Locate the left-hand side into the burner bracket.
- 7.30 Lower the right-hand side to engage the injector onto the venturi and also the pilot into the aperture in the burner skin.

- 7.31 Push the burner to the right and engage the burner into the slot in the bracket (see Diagram 32).

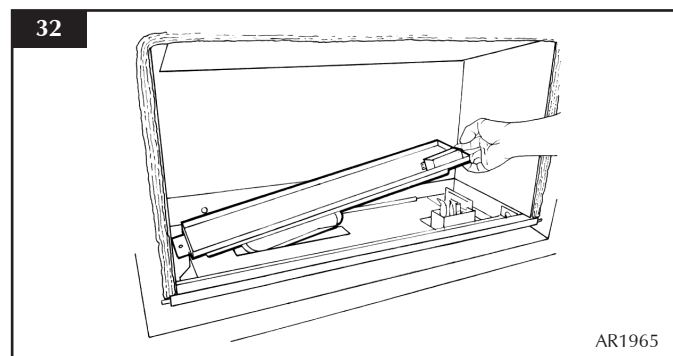

- 7.32 Replace the fixing screw.
- 7.33 To replace the doors and panels refer to Replacing Parts, Sections 3, 5 and 6.

METHOD 2 - NO FRAME

The front of the chimney breast has to be studded and boarded to allow the edge kit to be fitted.

Cool Wall:

For this cool-wall Edge installation, the convected heat produced by the appliance is channelled into the cavity between the existing chimney and the false wall, then vented at the top. The vent should have a minimum open area of 200mm.

- 7.34 Proceed as described in Section 7.1 to 7.16, but do not fit the frame brackets.
- 7.35 Once the box has been removed from the appliance fit the edge kit to the two sides and lower edge using the screws and expansion plugs provided (see Diagram 33).

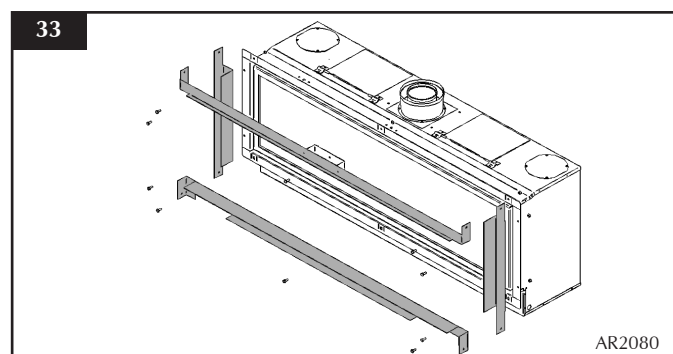

- 7.36 Stud the face of the chimney breast as described in Section 6, above.

DO NOT FIX ANY HORIZONTAL STUD WORK ABOVE THE APPLIANCE AS THIS WILL PREVENT THE CONVECTED AIR ESCAPING THROUGH THE VENTS.

INSTALLATION INSTRUCTIONS

INSTALLATION

7.37 Fit the non-combustible board and the plasterboard as described in Section 3.

7.38 Apply plaster skim to the front of the chimney breast.

Edge Kit:

7.39 Apply the same method for an Edge finish as described in the Cool Wall section above, referring also to Section 5.

MASONRY INSTALLATION FOR METHODS 1 & 2

7.40 Remove the compression elbow from the appliance and connect it to the gas supply pipe.

7.41 As the loose box is fitted into the main appliance pass the elbow and supply pipe through the silicone panel on the left side.

7.42 Engage the rear of the box onto the three studs on the rear of the appliance and lower the front edge.

7.43 Replace the three wing nuts and seven screws.

7.44 Replace the rear loose panel.

7.45 Ensure the lower edge engages into the tapered brackets.

7.46 **PURGE THE SUPPLY PIPE.** This is essential to expel any debris that may block the gas controls.

7.47 Connect the elbow to the appliance inlet pipe (see Diagram 34).

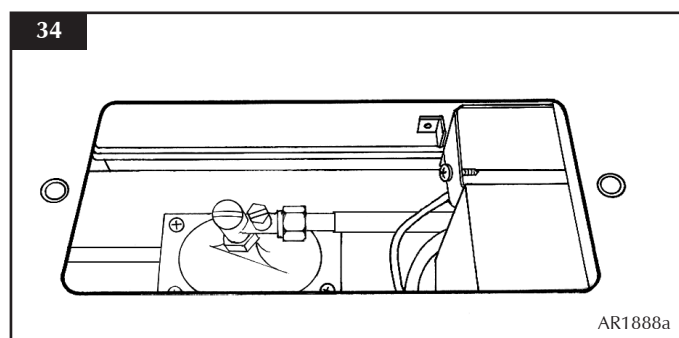

7.48 Connect a suitable pressure gauge to the test point located on the inlet fitting.

7.49 Turn on the gas.

The burner must be temporarily fitted whilst completing this procedure.

7.50 Light the appliance and check for leaks.

7.51 Turn the appliance to maximum and check that the supply pressure is as stated on the data badge.

7.52 Turn off the gas and replace the test point screw.

7.53 Turn the gas back on and check the test point for leaks.

7.54 Replace the splitter plate and burner.

8. ALL TYPES OF INSTALLATION INTO STUDWORK - WALL BOX & BATTERIES

8.1 Decide on the position for the wall box containing the batteries and wall switch.

NOTE:

A combined battery power supply and touch control cable is supplied and pre-fitted to the appliance control. Provision is made for the cable to exit either the left or right of the appliance through the grommet. The cable is 3 metres long.

When deciding the route of the cables consideration must be given to avoiding contact with the appliance and the flue system.

8.2 Correctly position the three new high quality (Duracell or similar) size C / HR14 batteries into the battery holder. Replace the cover by sliding it on to the battery holder.

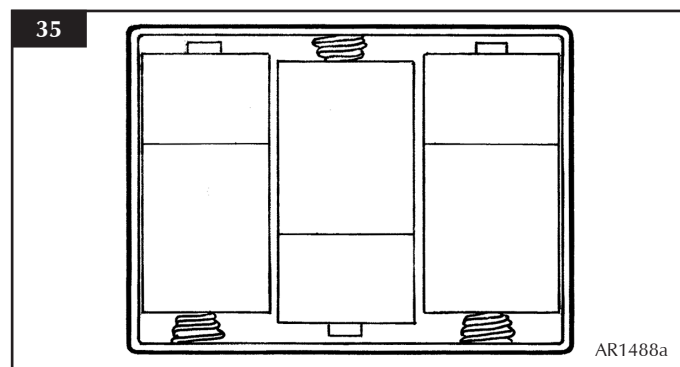

8.3 Slide the battery box into its housing in the back of the wall plate (see Diagram 36).

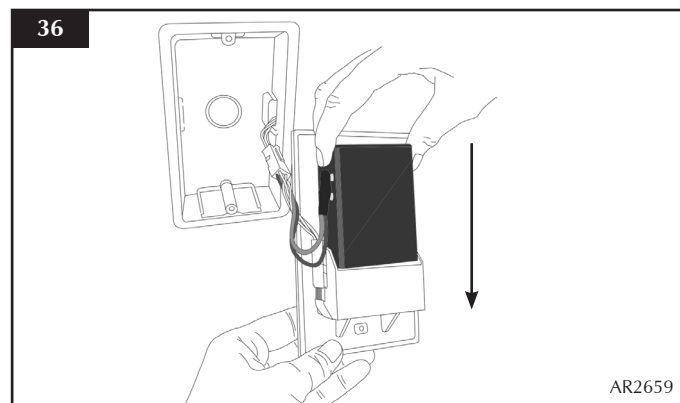

INSTALLATION INSTRUCTIONS

INSTALLATION

- 8.4 Ensure both sets of wires are connected (see Diagrams 37 & 38). **When replacing the 4 pronged connector ensure that the arrows are aligned.**

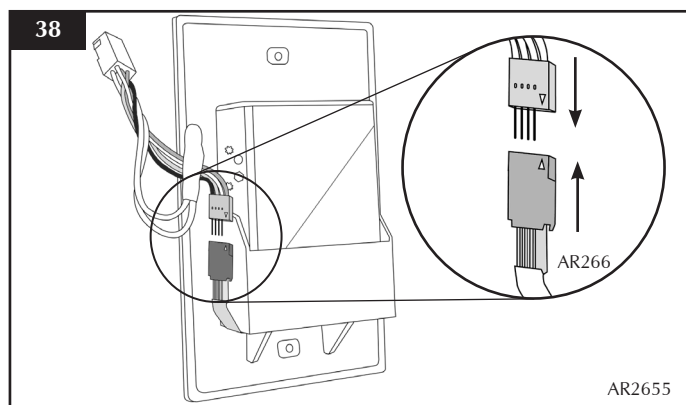
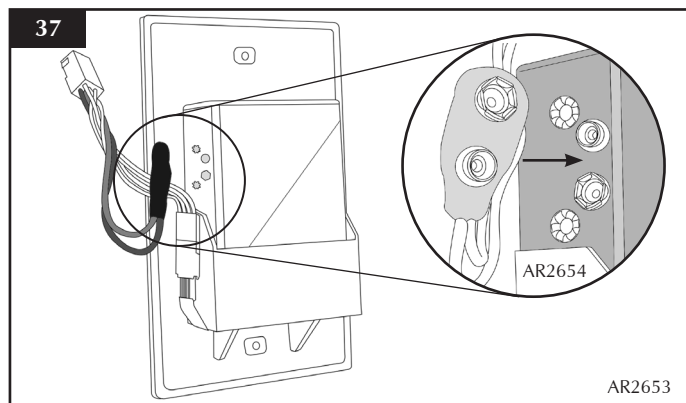

- 8.4 Connect the cable from the appliance to the touch pad cable (see Diagram 39).

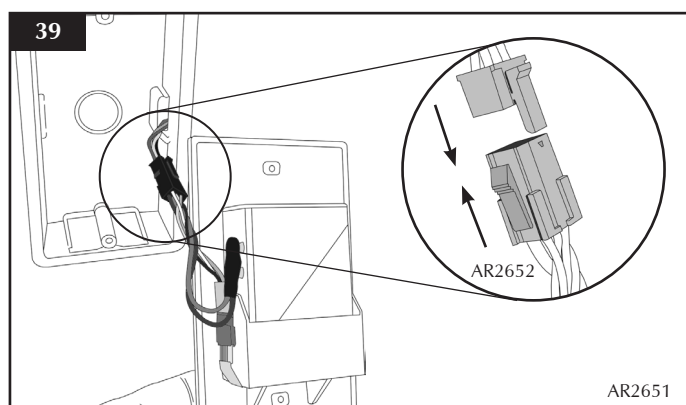

- 8.5 **IMPORTANT: THE WALL SWITCH MUST BE INSTALLED USING THE PLASTIC DRY LINING BOX SUPPLIED.**

Secure the wall plate to the dry lining box with the 2 x screws provided (see Diagram 40).

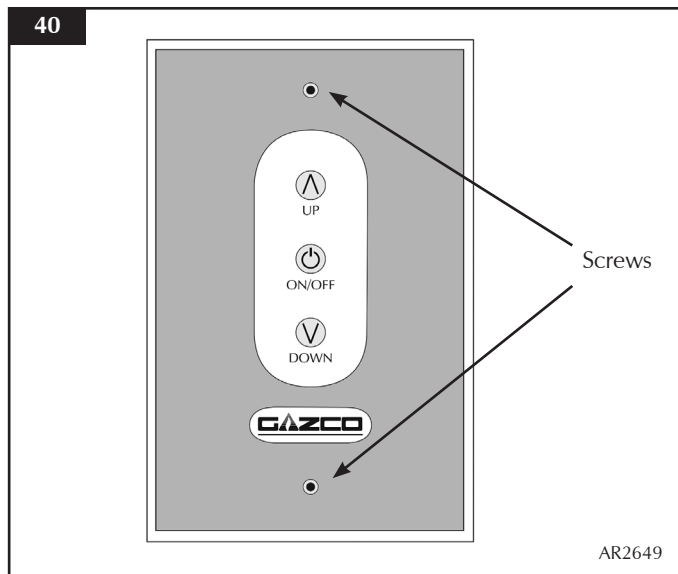

PLEASE ENSURE NO WIRES ARE TRAPPED BEFORE REPLACING THE WALL PLATE. THE TOUCH PAD LEAD IS EASILY DAMAGED.

9. ASSEMBLING THE APPLIANCE

- 9.1 Add the stone chippings or vermiculite, making sure they are flattened and level with the rim of the tray.

TAKE CARE NOT TO SPILL STONE CHIPPINGS OR VERMICULITE INTO THE PILOT AREA. ONLY STONE CHIPPINGS OR VERMICULITE SUPPLIED BY GAZCO CAN BE USED IN THIS APPLIANCE.

Vermiculite Only: Use the exact amount of vermiculite supplied. This is just enough to cover the burner.

- 9.2 The back panel is already in place. Place the bottom panel(s) at the base of the appliance.

For Studio 2 Only:

- 9.3 Locate the bottom edge of the liner behind the bracket on the support bar.

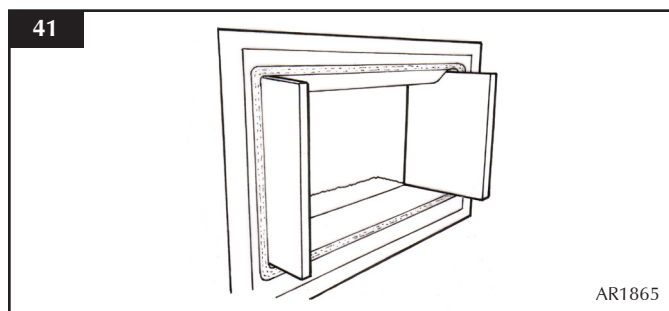

INSTALLATION INSTRUCTIONS

INSTALLATION

VERMICULITE PANELS

NOTE: STUDIO 1 & 2 FRONT PANELS AND STUDIO 2 REAR PANELS ARE IN TWO PIECES:

HOLD THE REAR PANELS UNTIL ALL THE OTHER PANELS ARE IN PLACE AS THEY CAN FALL FORWARD

- 9.4 Place the rear panel(s) behind the locating bracket on the rear support bar.

The Studio 1 rear panel is already in place.

- 9.5 Ensure the two-piece rear panels are centralised, with the chamfers touching and pushed together (see Diagram 42).

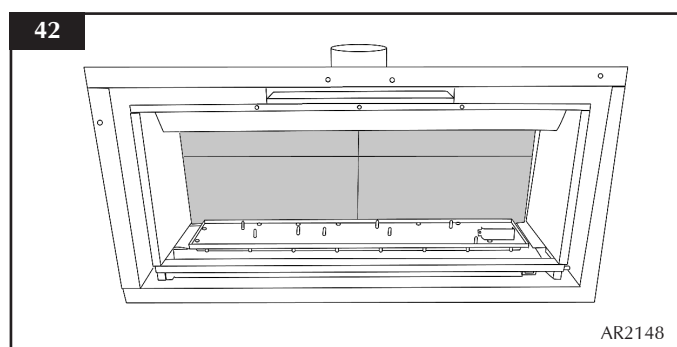

- 9.6 Place the lower side and front panels in position so the chamfers meet at the front edge of the burner.
- 9.7 Ensure the two-piece front panels are engaged against the centre support tags on the burner and are pushed together in the middle (see Diagram 43).

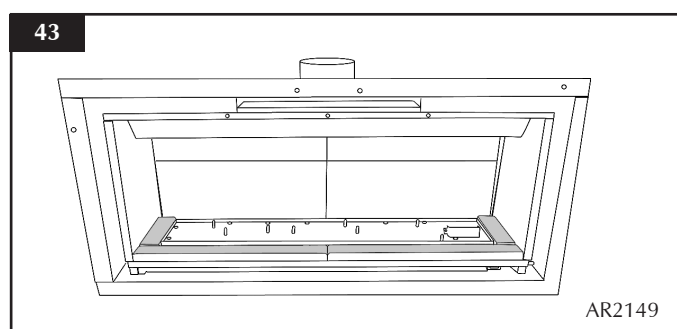

- 9.10 Slide the two side panels up to the rear panel (see Diagram 44).

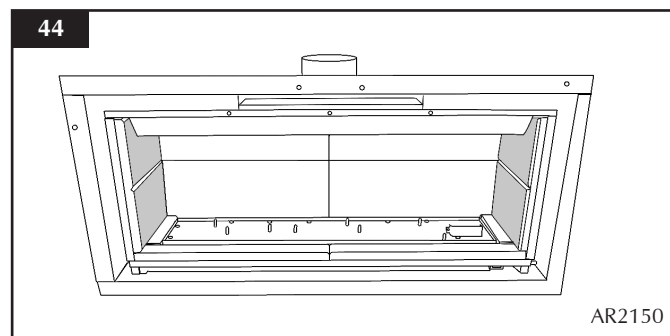

Note: THE HORIZONTAL CHAMFERS MUST ALIGN ON THE REAR AND SIDE PIECES.

10. ARRANGEMENT OF FUEL BED

ADVICE ON HANDLING AND DISPOSAL OF FIRE CERAMICS

The fuel effect of the log version of this appliance is made from Refractory Ceramic Fibre (RCF), a material which is commonly used for this application.

Protective clothing is not required when handling these articles, but we recommend you follow normal hygiene rules of not smoking, eating or drinking in the work area and always wash your hands before eating or drinking.

To ensure that the release of RCF fibres are kept to a minimum, during installation and servicing a HEPA filtered vacuum is recommended to remove any dust accumulated in and around the appliance before and after working on it.

When servicing the appliance it is recommended that the replaced items are not broken up, but are sealed within heavy duty polythene bags and labelled as RCF waste.

RCF waste is classed as stable, non-reactive hazardous waste and may be disposed of at a licensed landfill site.

Excessive exposure to these materials may cause temporary irritation to eyes, skin and respiratory tract; wash hands thoroughly after handling the material.

- 10.1 **Stone chippings:** If you need to replace stone chippings and refill the tray, make sure the stone chippings are flattened so they are level with the rim of the tray.
- 10.2 **Vermiculite for Logs Layout:** Use the entire bag of supplied Vermiculite.

TAKE CARE NOT TO SPILL STONE CHIPPINGS OR VERMICULITE INTO THE PILOT AREA. ONLY STONE CHIPPINGS OR VERMICULITE SUPPLIED BY GAZCO CAN BE USED IN THIS APPLIANCE.

INSTALLATION INSTRUCTIONS

INSTALLATION

11. LOG LAYOUT

LOGS MUST BE POSITIONED ACCORDING TO THE FOLLOWING INSTRUCTIONS TO GIVE THE CORRECT FLAME EFFECT

- 11.1 Use all the vermiculite to fill the burner tray and spread evenly across the whole burner.
- 11.2 Rest the ceramic bark against the front face of the pilot shield (see Diagram 45).

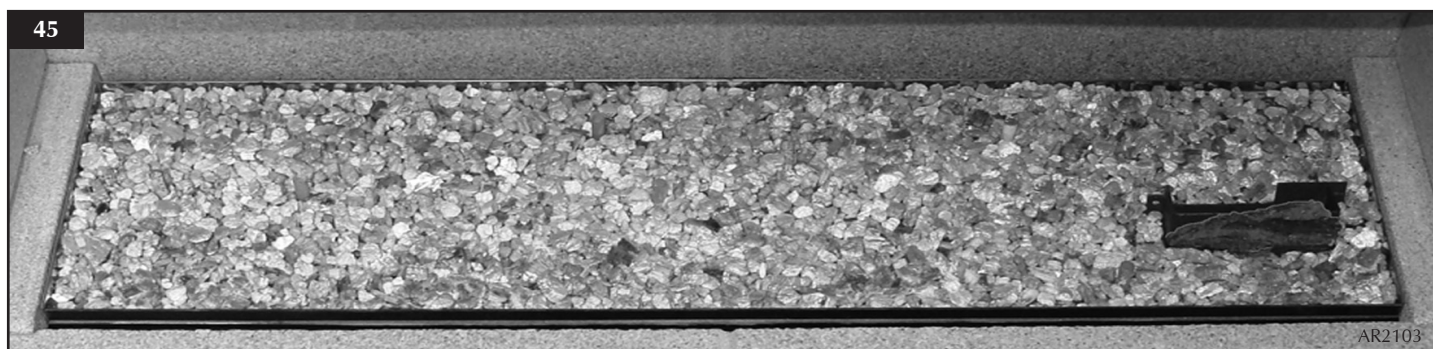

- 11.3 All logs can be identified by a letter (A - H) on their underside. The first three logs, A, B and C, also have holes to locate each onto a burner stud.
- 11.4 Working from left to right place logs A, B and C onto their studs as illustrated in Diagram 46.

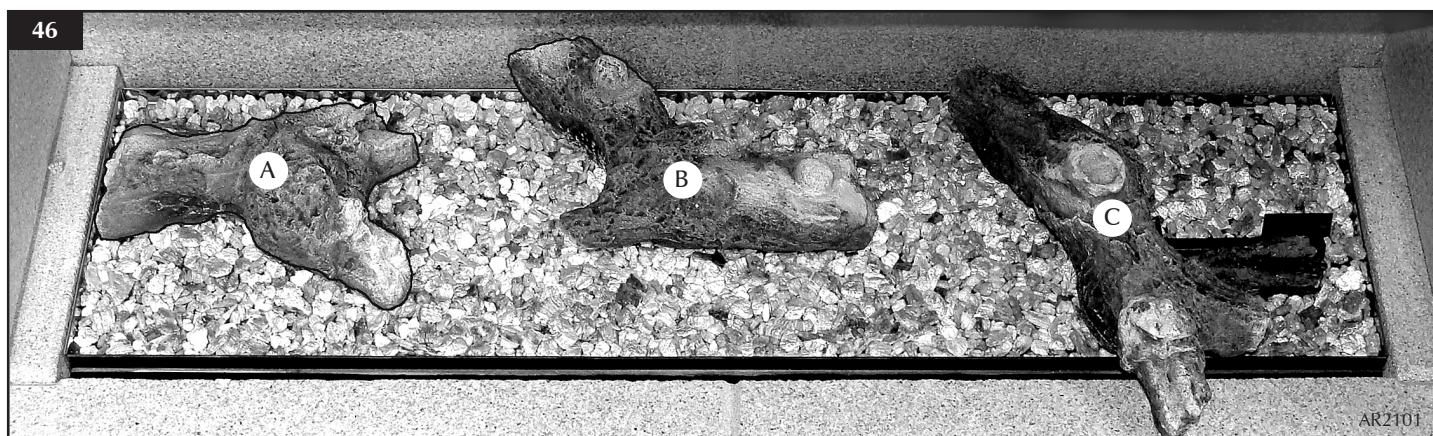
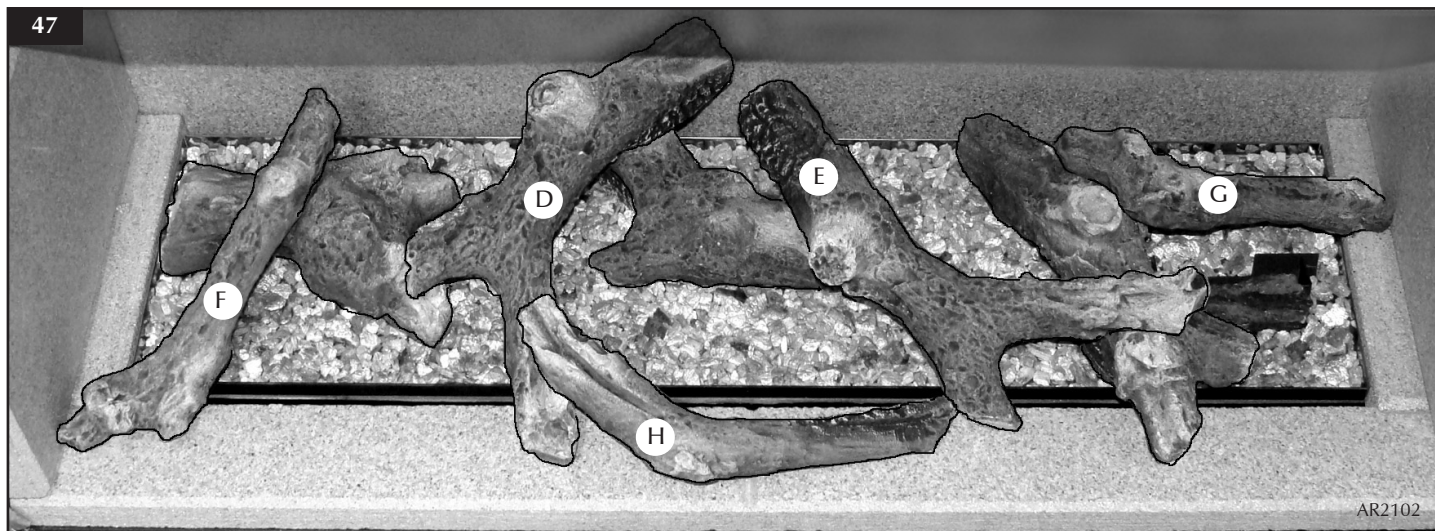

Diagram 47 shows the layout of logs D to H:

- 11.5 Log D has a recess on the underside to fit onto the stud of Log B at the back left. The small branch of the log rests on Log A.
- 11.6 A recess in the back of Log E fits the stud on Log B and its long branch rests snugly behind a wood knot of Log C.

INSTALLATION INSTRUCTIONS

INSTALLATION



11.7 Log F fits centrally onto Log A with its front edge resting on the front panel.

11.8 Log G is centrally positioned around the moulded wood knot of Log C and rests against the right side panel crossing the pilot shield beneath.

11.9 The small branch underneath Log H rests on the front panel and overlaps Log D just touching Log E.

LAYOUT FOR STUDIO 2

11.10 Preparation with vermiculite and the ceramic bark pilot shield is the same as for Studio 1 (see paragraph 11.1 above).

All logs can be identified by the letters (A - J) on their underside. The first four logs, I, A, B and C also have holes to locate each onto a burner stud.

11.11 Place logs I, A, B and C onto their studs as illustrated in Diagram 48.

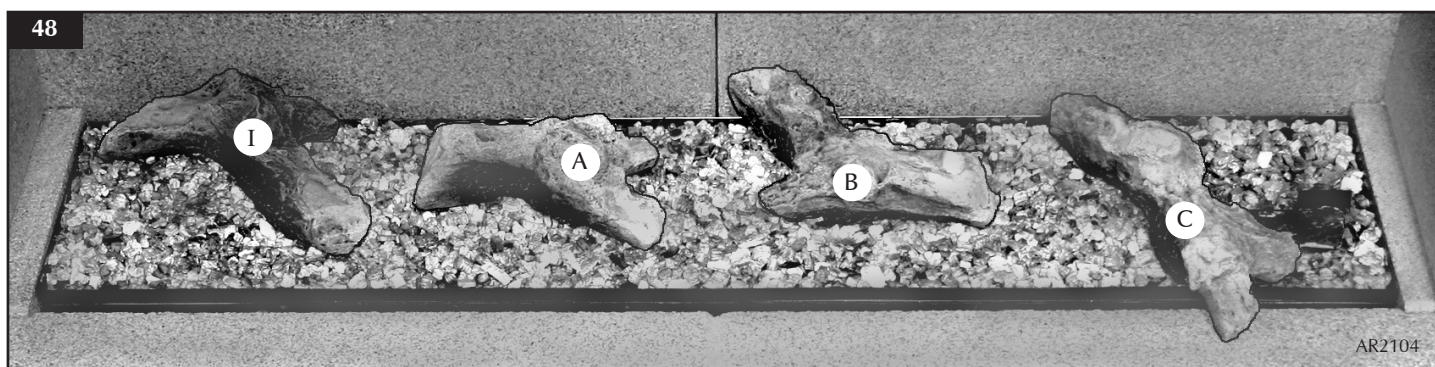

INSTALLATION INSTRUCTIONS

INSTALLATION

Diagram 49 shows the layout of logs D, E and J.

11.12 Log D has a recess on the underside to fit onto the stud of Log B at the back left. The small branch of the log rests on Log A.

11.13 A recess in the back of Log E fits the stud on Log B and its long branch rests snugly behind a wood knot of Log C.

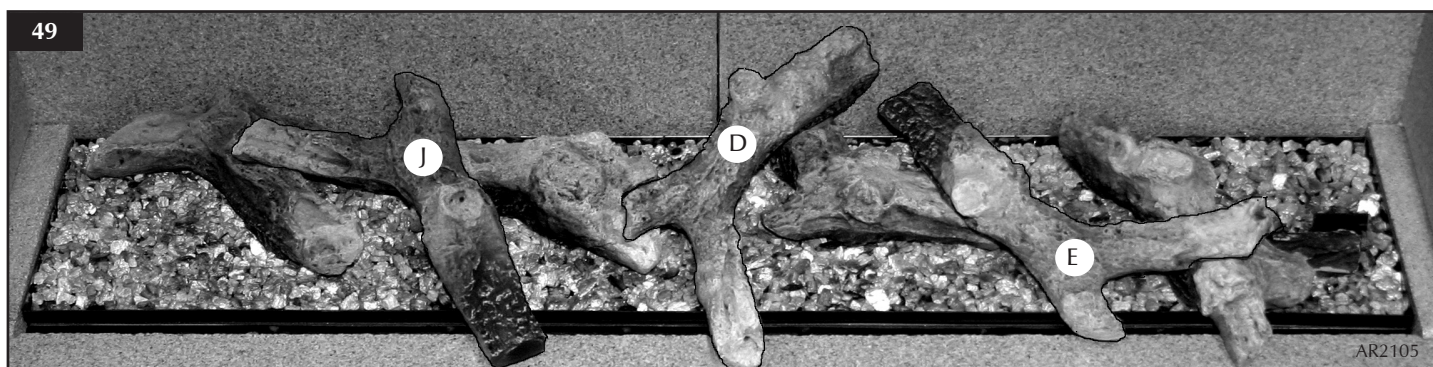

11.14 The underside of log J has a moulded 'stop'. This rests about 12mm in from the left edge of Log A. The left branch of Log J also rests in the recess in Log I (see Diagram 49 above.)

Diagram 50 shows the layout of the last four logs, F, G and two of log H.

11.15 Log F fits centrally onto Log I with its front edge resting on the front panel.

11.16 Log G is centrally positioned around the moulded wood knot of Log C and rests against the right side panel crossing the pilot shield beneath.

11.17 The first Log H rests on the front panel, overlapping Log D and touching Log E.

11.20 The second Log H rests anywhere on the front panel between F and J. **DO NOT LET THIS LOG OVERLAP THE BURNER.**

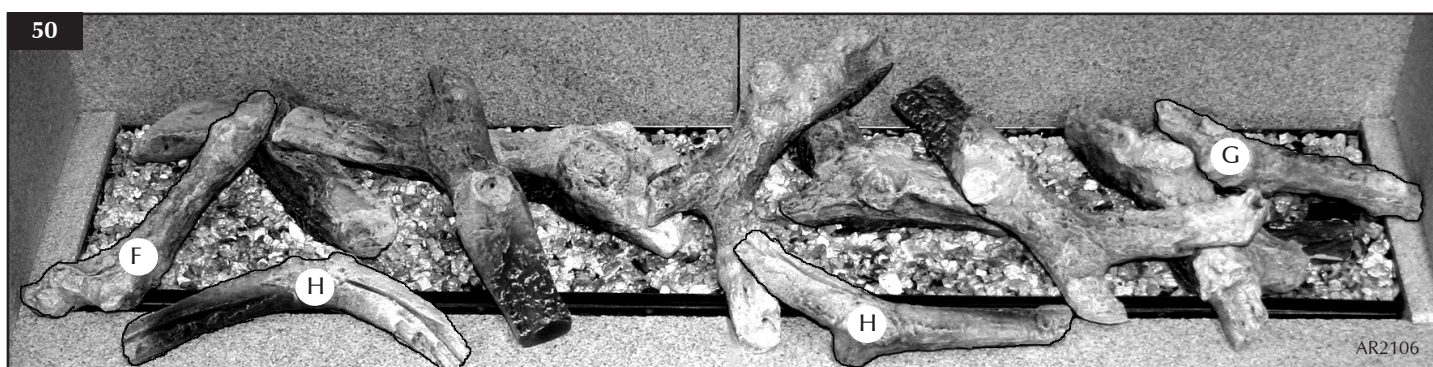

INSTALLATION INSTRUCTIONS

INSTALLATION

12. COMPLETION OF ASSEMBLY

To fit the window frame:

- 12.1 Keep the frame in the upright position with the locks uppermost.
- 12.2 Offer the frame to the foot of the opening.
- 12.3 Slide the frame to the right to locate the right hinge pin.

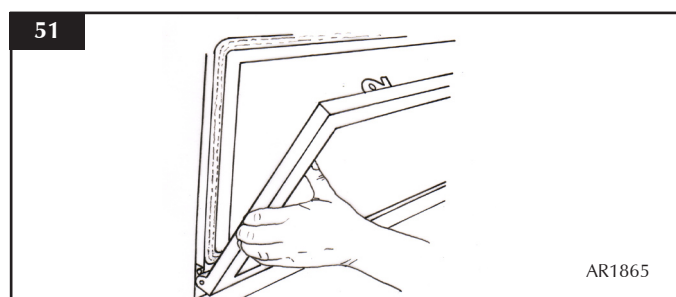

- 12.4 Manoeuvre the frame up towards the left side to locate the left hinge pin.
- 12.5 Slide onto the hinge with a right movement.
- 12.6 Secure in place with a spring clip at the right hinge pin (see Diagram 52).

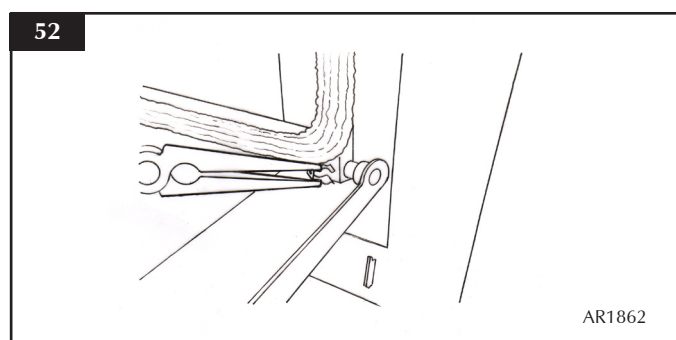

- 12.7 Close the window.
- 12.8 Using the hexagon key provided close the window locks by moving from open to shut towards the window centre.

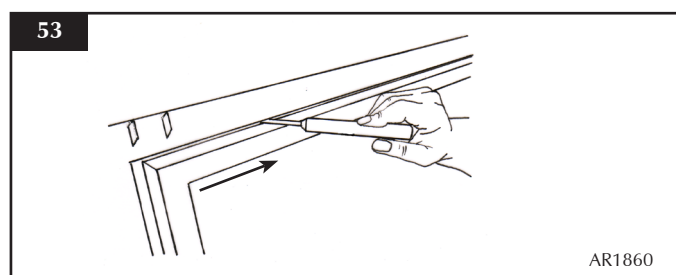

13. OPERATING THE STUDIO

- 13.1 The appliance can be operated in two ways:
 - Using the fully programmable remote control unit.
 - Using the touch pad control on the wall switch.
- 13.2 The appliance has four flame settings which can be controlled manually or automatically via temperature sensing:
 1. Standby (Pilot only).
 2. Low (Pilot lit and main burner lit at the minimum flame setting).
 3. Med (Pilot lit and main burner lit at the medium flame setting).
 4. High (Pilot lit and main burner lit at the highest flame setting).

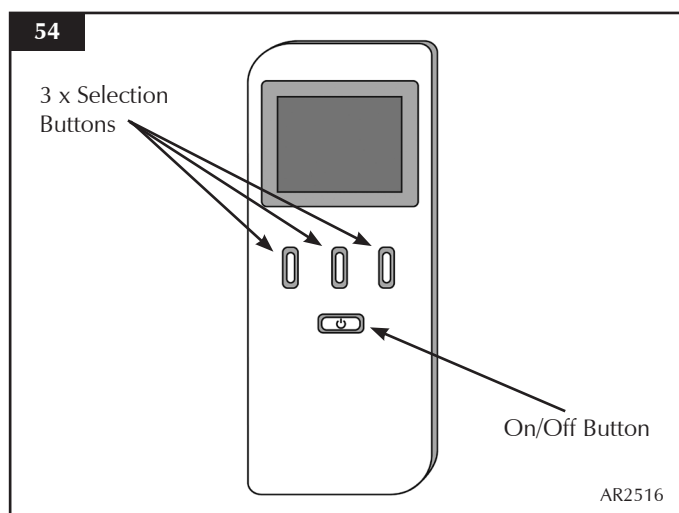

13A. FULLY PROGRAMMABLE REMOTE CONTROL HANDSET

- 13.3 The remote control handset has been factory set to only communicate with the appliance it is supplied with. The appliance will not respond to any other remote control, even one from an identical appliance.

Note: In the event of a replacement handset being acquired, pairing of the handset with the appliance will need to be carried out. Please refer to Commissioning, Section 2, Pairing Handset on page 39.

INSTALLATION INSTRUCTIONS

INSTALLATION

13.4 The handset has been factory configured with the following options:

- a) Auto thermostat mode enabled - the flame height will alter automatically to achieve a desired room temperature (when set).
- b) Gap temperature set at 2°C - if the handset temperature display falls 2°C below the fixed temperature when in standby mode (pilot only) the appliance will automatically ignite the main burner at the low flame setting.
- c) Programming - allowing a daily or weekly program of operation to be set.
- d) Soft start enabled - in thermostat mode there is a 10 second delay between flame settings when more than one change of setting is required i.e. from High to Low).
- e) Sounder ON - accepted operations via the handset will initiate a beep from the appliance control).
- f) Safety Temperature - pre-set to switch the appliance off if the remote temperature display exceeds 40°C.

Before using the remote control:

- 13.5 Ensure batteries are fitted (2x AA 1.5v high quality (Duracell or similar) alkaline - DO NOT USE RECHARGEABLE).
- 13.6 If there is no display on the LCD screen press any key.

NOTE: To select a function from the options displayed at the bottom of the screen press the button directly below the desired function (see Diagram 55).

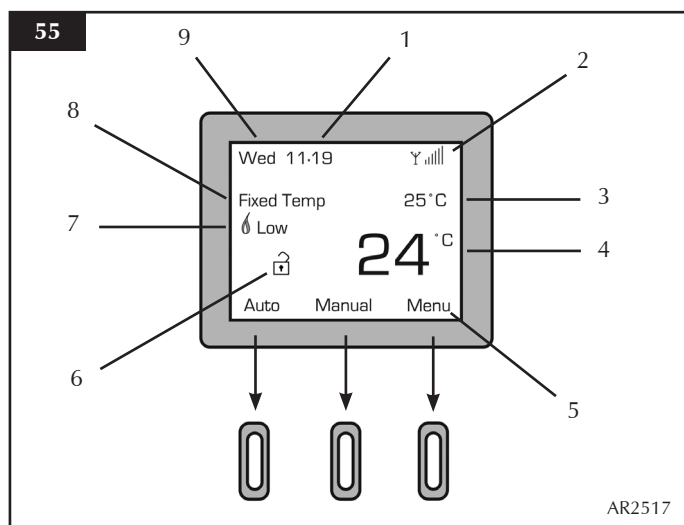

- 13.7 When first powered, the handset displays the OFF screen. The handset may also be locked as indicated by the symbol (🔒).
- 13.8 To unlock the handset select Unlock followed by OK - the symbol will change to (🔓).

13.9 The LCD screen displays the following information (see Diagram 55):

- 1) Time
- 2) Signal strength (between handset and appliance)
- 3) Selected Setting - selected flame setting (highlighted) or desired temperature if in auto mode
- 4) Current room temperature
- 5) Button function
- 6) Child lock status
- 7) Current flame status
- 8) Selected Mode - Manual / Auto (Thermo / Fixed Temp) / Program - when appliance is switched on
- 9) Day of the week

To set or adjust the items on the display:

13.10 Select Menu from the bottom right of the main screen.

13.11 Select Adjust Menu.

In this menu it is possible to set the:

- Temperature Unit (°C or °F)
- Language
- Autolock (On/Off)
- Day
- Hour
- Minute
- Comfort temperature
- Night temperature

In addition access can be gained to the programmable functions via the Change Prog option (see Section 13C).

Note: The current day and time must be set in order for the programmable functions to work.

- 13.12 Using the button below the symbol (↓) scroll down to Day and press the button below Select. Use the buttons below the symbols (↑) and (↓) to set the day of the week.
- 13.13 Press the button below Back, scroll down to Hour and select it. Use the buttons below the symbols (↑) and (↓) to set the hour.
- 13.14 Press the button below Back, scroll down to Minute and select it. Use the buttons below the symbols (↑) and (↓) to set the minutes.
- 13.15 The same process can be used to set any of the functions within this menu.

INSTALLATION INSTRUCTIONS

INSTALLATION

13.16 There are 3 different modes available for controlling and operating the appliance:

1. Manual Mode
2. Automatic Mode
3. Program Mode

Refer to Section 13B for full details.

NOTE: WHEN OPERATING THE APPLIANCE IN AUTOMATIC OR PROGRAM MODE, THE PILOT REMAINS LIT AND THE MAIN BURNER AUTOMATICALLY SWITCHES ON AT PROGRAMMED TIMES TO BRING THE ROOM TO THE SET TEMPERATURE WHETHER OR NOT YOU ARE IN THE ROOM. NEVER LEAVE ANY COMBUSTIBLE MATERIALS WITHIN 1 METRE OF THE FRONT OF THE APPLIANCE.

13B. SETTING THE MODE OF OPERATION

1. Manual Mode

The Manual mode can be used to turn the appliance on and alter flame height and, therefore, temperature.

To use the manual mode of operation:

13.17 If there is no display on the LCD screen press any key.

If the appliance is off (no pilot flame) the handset will display the word OFF.

The handset may also be locked as indicated by the symbol (🔒).

13.18 To unlock the handset select Unlock followed by OK - the symbol will change to (🔓).

13.19 Select On followed by OK. The appliance will emit a single beep and the pilot will light.

Note: There may be a slight delay between pressing the remote and the appliance responding.

13.20 Select Manual and the screen will highlight the current flame setting (Pilot).

13.21 To light the main burner select (↑). The screen will highlight the current flame setting (Low) and the main burner will light at the Low setting.

13.22 Use the buttons directly below the symbols (↓) and (↑) to increase or decrease the flame setting between the Pilot and the High setting.

13.23 To turn off the appliance press the ON/OFF button once (see Diagram 54).

13.24 To lock the handset select Lock.

NOTE: If the Safety Temperature (see Section 2.10 f) is exceeded then the appliance will turn itself off.

2. Auto Mode

The auto mode of operation allows the user to pre-set the desired room temperature. The appliance will control the flame setting automatically to maintain this temperature.

To use the auto mode of operation:

13.25 If there is no display on the LCD screen press any key.

13.26 If the appliance is off (no pilot flame) the handset will display the word OFF.

13.27 The handset may also be locked as indicated by the symbol (🔒).

13.28 To unlock the handset select Unlock followed by OK - the symbol will change to (🔓).

13.29 Select On followed by OK. The appliance will emit a single beep and the pilot will light.

13.30 Select Auto. The screen will display the word Thermo and the set room temperature will be highlighted.

13.31 To adjust the desired room temperature use the buttons directly below the symbols (↓) and (↑). The set temperature can be adjusted between 0°C and 37°C.

The flame setting required to achieve the desired room temperature will be displayed below the word Thermo.

13.32 In accordance with the factory configurations the following will apply:

a) For every 1°C below the set temperature the flame height will increase.

b) For every 1°C above the set temperature the flame height will decrease.

c) There will be a delay of 10 seconds between each automatic flame setting adjustment.

13.33 Once the desired room temperature has been set, select Back to return to the main screen.

13.34 The main screen will now display the words Fixed Temp, the set temperature (e.g. 21°C) and the current room temperature (largest number). To change the set temperature at any time select Auto and follow 13.31 above.

INSTALLATION INSTRUCTIONS

INSTALLATION

13.35 To exit the Auto mode at any time select Manual from the bottom of the screen and follow Section 13.18 - 13.25.

3. Program Mode

The program mode of operation allows the appliance to be pre-set to a choice of temperature options on a daily or weekly cycle. The appliance will automatically operate and control the flame setting to maintain pre-set hourly temperatures during each 24hr period. **To set a daily row weekly program please refer to Section 13C.**

LOW BATTERY

If the batteries in the remote control handset become discharged the LCD display will show the message Low Battery.

NOTE: Only replace the handset batteries with high quality (Duracell or similar) type AA 1.5v alkaline. DO NOT USE RECHARGEABLE BATTERIES.

REMOTE SIGNAL STRENGTH

13.36 If the appliance does not respond to the handset, check the strength of the reception signal in the top right hand corner of the LCD display (Y||||).

If there are no vertical bars next to the signal symbol (Y) then communication between the appliance and the handset has been lost. If the communication loss exceeds 18 minutes then the appliance will emit 20 beeps and switch OFF. Try the following:

13.37 Move the handset closer to the appliance.

NOTE: Try to avoid placing the handset a long distance from the appliance. It can take some time for the signal to return.

13.38 Replace the batteries in the handset.

13.39 If there is still no signal, operate the appliance using the touch pad control on the wall switch (refer to Section 13D) and consult your installer or Gazco dealer.

13C. PROGRAM MENU

13.40 The program menu can be used to pre-set the appliance to function automatically.

There are two types of program mode:

1. Daily mode - the temperature can be selected (from a range of settings) for each hour over a 24hr period - the set pattern is then repeated every day.

2. Weekly mode - the temperature can be selected (from a range of settings) for each hour over a 24hr period for each individual day of the week (Mon - Sun).

Note: In order for the programmable functions to work the current day and time must be set first, see Section 13.11.

13.41 One of 3 pre-set temperature options can be chosen for each hour across the 24 hour period:

- Off - the appliance will remain in Standby mode (pilot only - please note the appliance will not switch off completely when in program mode)
- Night Temp - the appliance will operate automatically to maintain the pre-set night temperature.
- Comfort Temp - the appliance will operate automatically to maintain the pre-set comfort temperature.

13.42 To set the Comfort and Night temperature refer to Section 13.11.

13.43 To access the program menu select Menu. In the next screen select Adjust Menu. Use the button directly below the symbol (↓) scroll to Change Prog and select. The programming screen will be displayed as shown in Diagram 56.

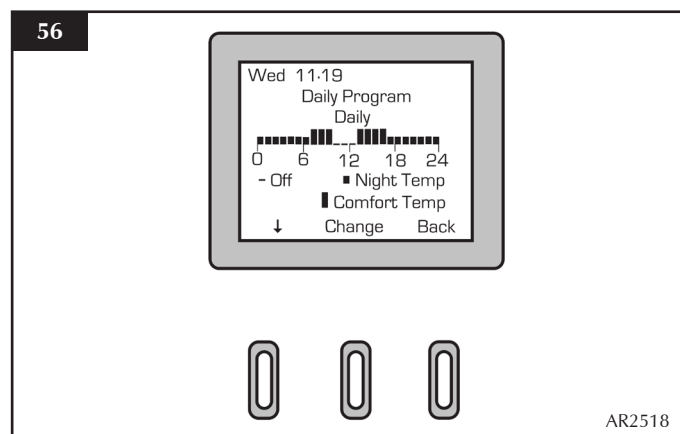

To set a Daily program of operating times:

13.44 In the program menu the word Daily should be highlighted. Press the button below the symbol (↓) to access the 24 hour timer (see Diagram 56). The arrow should now point to the right (→).

13.45 The timer reads 0 - 24 with 0 representing midnight. Press the button below the symbol (→) to scroll through the 24 hour timer. With the cursor resting on the chosen hour, press Change until you have reached the desired setting for that hour. Use the button below the symbol (→) to scroll to the next hour and select the desired function for each hour until all 24 hours are set.

To set a weekly program of operating times:

13.46 Select the day of the week (Mon - Sun) using the button below the word Change. Select the function settings for each hour of the given day as detailed in 13.45 above.

INSTALLATION INSTRUCTIONS

INSTALLATION

13.47 Once the programming is completed select Back to return to the main screen.

To launch the program:

Note: The appliance must be ON (pilot lit or any flame setting) in order to launch the program.

13.48 Select Menu. In the next screen use the button directly below the symbol (↓) to scroll to Program and select it. Select Change until the highlighted text reads ON.

13.49 Select Back and use the button directly below the symbol (↓) to select Prog Type. Press the button directly below the word Select followed by Change until the desired program (Daily or Weekly) is selected. Select Back twice to return to the main screen.

13D. TOUCH PAD CONTROL

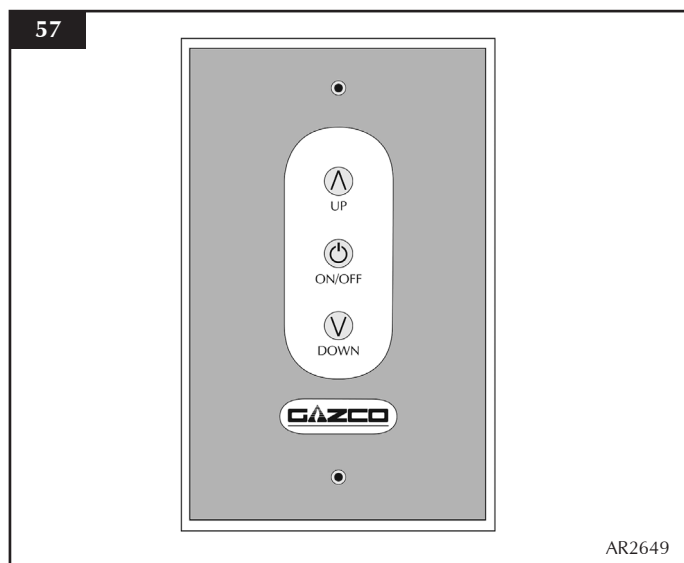

The touch pad control is located on the front of the wall switch and allows manual operation of the appliance (see Diagram 57).

With the touch pad it is possible to turn the appliance ON, OFF and control the flame setting.

NOTE: When using the touch pad buttons the red LED will briefly illuminate and a beep will be emitted from the appliance to indicate an accepted command.

To Switch ON:

13.50 To turn the appliance ON press the ON/OFF button once. The ignition sequence will commence. This may take up to 20 seconds. The pilot will be lit once the start up sequence has completed.

13.51 If the pilot fails to light, press the ON/OFF button again to switch OFF. Wait for at least 30 seconds before attempting to switch on again.

To change the flame level:

13.52 With the Pilot lit the appliance is in Standby mode.

13.53 Press the button below the symbol (↑) once. The main burner will be ignited on the Low flame setting.

13.54 Press the button below the symbol (↑) once more to increase the flame setting to the Medium position.

13.55 Press the button below the symbol (↑) once more to increase the flame setting to the High position.

13.56 To reduce the flame, press the button below the symbol (↓). At the lowest setting only the Pilot will be lit and the appliance will be in Standby mode.

To Switch OFF:

13.57 To turn the appliance OFF press the ON/OFF button. The pilot flame will be extinguished.

NOTE: Following main burner operation do not attempt to switch on the appliance again for at least 3 minutes.

TOUCH PAD CONTROL NOT WORKING

If the appliance is not operating with the touch pad control:

13.58 In accordance with User Instructions, Section 4, replace the batteries in the wall switch unit.

13.59 If the appliance still fails to operate consult your installer or Gazco dealer.

14. LIGHTING THE APPLIANCE

14.1 Using either the manual mode of the remote handset (see Section 13B) or the touch pad control (Section 13D) ignite the appliance and operate at the highest flame setting.

INSTALLATION INSTRUCTIONS

COMMISSIONING

1. COMMISSIONING

- 1.1 Check the flame picture, log/pebble layout.
- 1.2 Check the gas pressure.
- 1.3 Close all door and windows in the room.
- 1.4 Ignite the Studio and operate on maximum for 5 minutes.
- 1.5 Position a lighted smoke match just inside the draught diverter opening and check all smoke is drawn in along the opening.

If there is any doubt:

- 1.6 Run the appliance for a further 10 minutes and repeat the test (see Diagram 1).

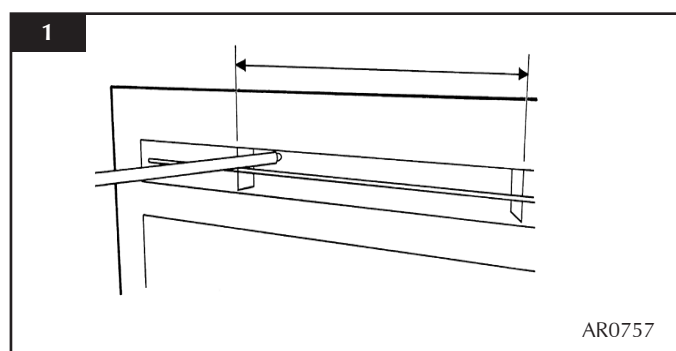

- 1.4 Guide the user through the User Instructions paying particular attention to:
 - a) Regular servicing (Section 9 of the User Instructions).
 - b) Ventilation (Section 10 of the User Instructions) - point out the ventilation positions where applicable.
 - c) Hot surfaces (Section 12 of the User Instructions).
 - d) How the appliance works with the touch pad control (Section 2B of the User Instructions).
 - e) How the appliance works with the remote control handset and the modes of operation (Section 2A of the User Instructions).
 - f) How to change settings in the auto mode and program modes of operation.
 - g) What to do if the appliance fails to operate (Section 13 of the User Instructions).

If there are any extractor fans in the room or adjacent rooms, the test must be repeated with the fans running on maximum.

IF SPILLAGE PERSISTS, DISCONNECT THE APPLIANCE AND SEEK EXPERT ADVICE.

For future reference, record the installation details on the *Commissioning Sheet* on page 3.

2. PAIRING THE APPLIANCE

If there is no communication between the remote handset and the appliance, or if the handset is replaced, it will be necessary to pair the (new) handset with the appliance.

- 2.1 Ensure batteries are fitted and working in the handset.
 - 2.2 Re-fit the touch pad control cable and the battery power supply cable to the control box.
 - 2.3 Press the ON/OFF button for 40 seconds until the configuration screen appears.
 - 2.4 When the configuration menu screen appears ensure the Pairing option is set to ON using the Change button.
 - 2.5 Within 20 seconds press the yellow button on the control unit (see Diagram 17, page 47). This may be easier using a pencil, ball point pen or similar.
 - 2.6 The control will emit a single beep to confirm the pairing operation and the remote handset will display a signal level in the top right hand corner.
- If there are any difficulties achieving pairing ensure that the handset is set to Channel A. To do this follow the steps below:**
- 2.7 Press the ON/OFF button for 40 seconds until the configuration screen appears.
 - 2.8 Scroll down the menu using the (↓) button and select Channel A.
 - 2.9 Ensure the Pairing option is set to ON using the Change button.
 - 2.10 Disconnect the batteries from the control box and reconnect after 10 seconds.
 - 2.11 The motor on the valve will turn. Once it has stopped repeatedly press and release the yellow button on the control box until the control box emits a single beep to confirm the pairing operation has been successful.

SERVICING INSTRUCTIONS

SERVICING / FAULT FINDING CHARTS

1. SERVICING REQUIREMENTS

IMPORTANT – The glass panel on this appliance should be checked for any signs of damage on the front face of the glass panel (scratches, scores, cracks or other surface defects). If damage is observed, the glass panel must be replaced and the appliance must not be used until a replacement is installed. Under no circumstances should the appliance be used if any damage is observed. Please isolate the appliance until a replacement glass panel has been obtained and installed. Replacement glass panels can be purchased from Gazco via the dealer from which the appliance was purchased or any other Gazco distributor.

This appliance must be serviced at least once a year by a competent person.

All tests must be carried out in accordance with the current Gas Safe recommendations.

1.1 Before Testing:

- Conduct a gas soundness test for the property ensuring there are no leaks before servicing.
- Check the operation of the appliance before testing.

1.2 Special checks:

- Clean away lint or fluff from the pilot.
- Clean away lint or fluff from under the burner.
- Check the spark gap on the pilot is correct.

1.3 Correct any faults found during the initial test.

1.4 Re-commission the appliance in accordance with Commissioning Procedures as detailed on page 39 of these instructions.

1.5 Advise the customer of any remedial work undertaken.

REPLACE BATTERIES BEFORE ATTEMPTING TO RECTIFY ANY FAULTS.

IGNITION FUNCTIONAL CHECK 1

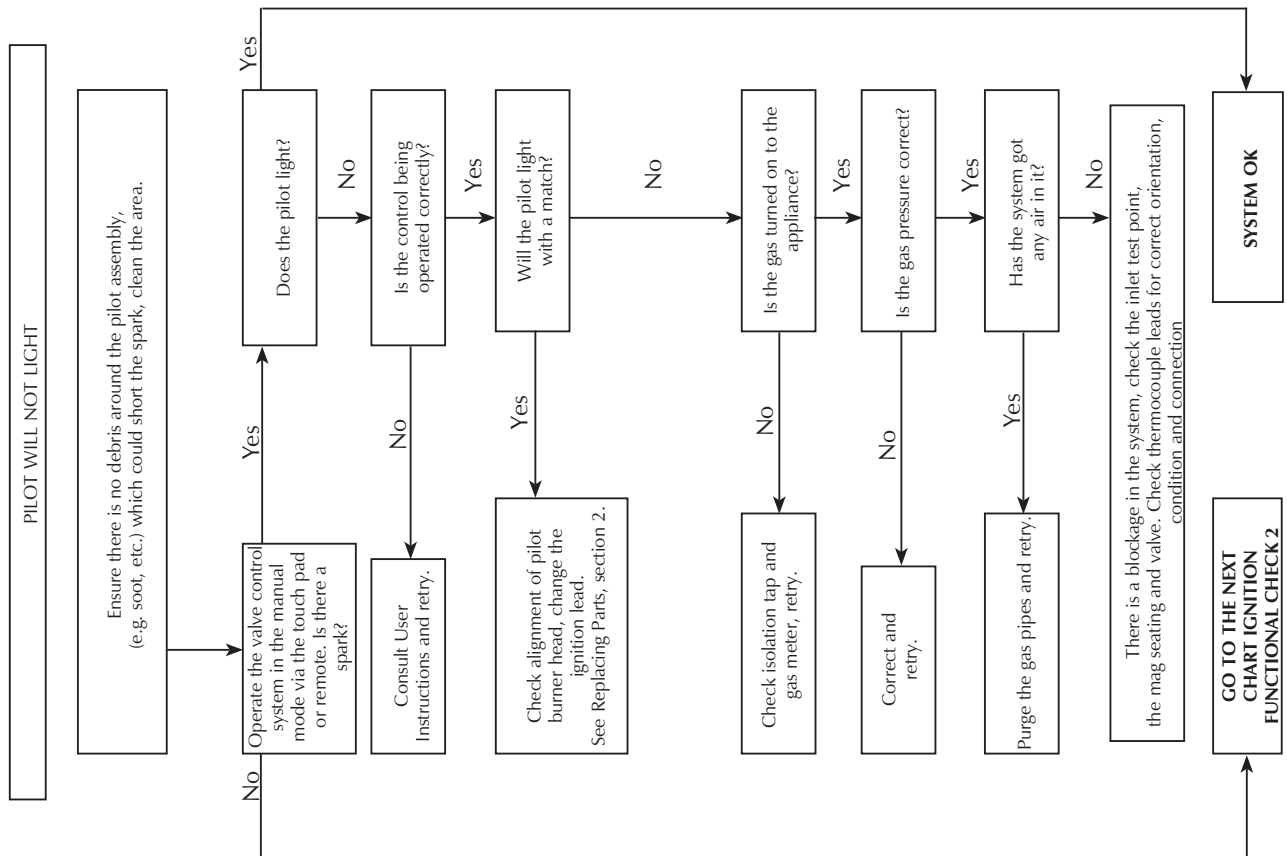

SERVICING INSTRUCTIONS

FAULT FINDING CHARTS

FLAME FAILURE FUNCTIONAL CHECK 3

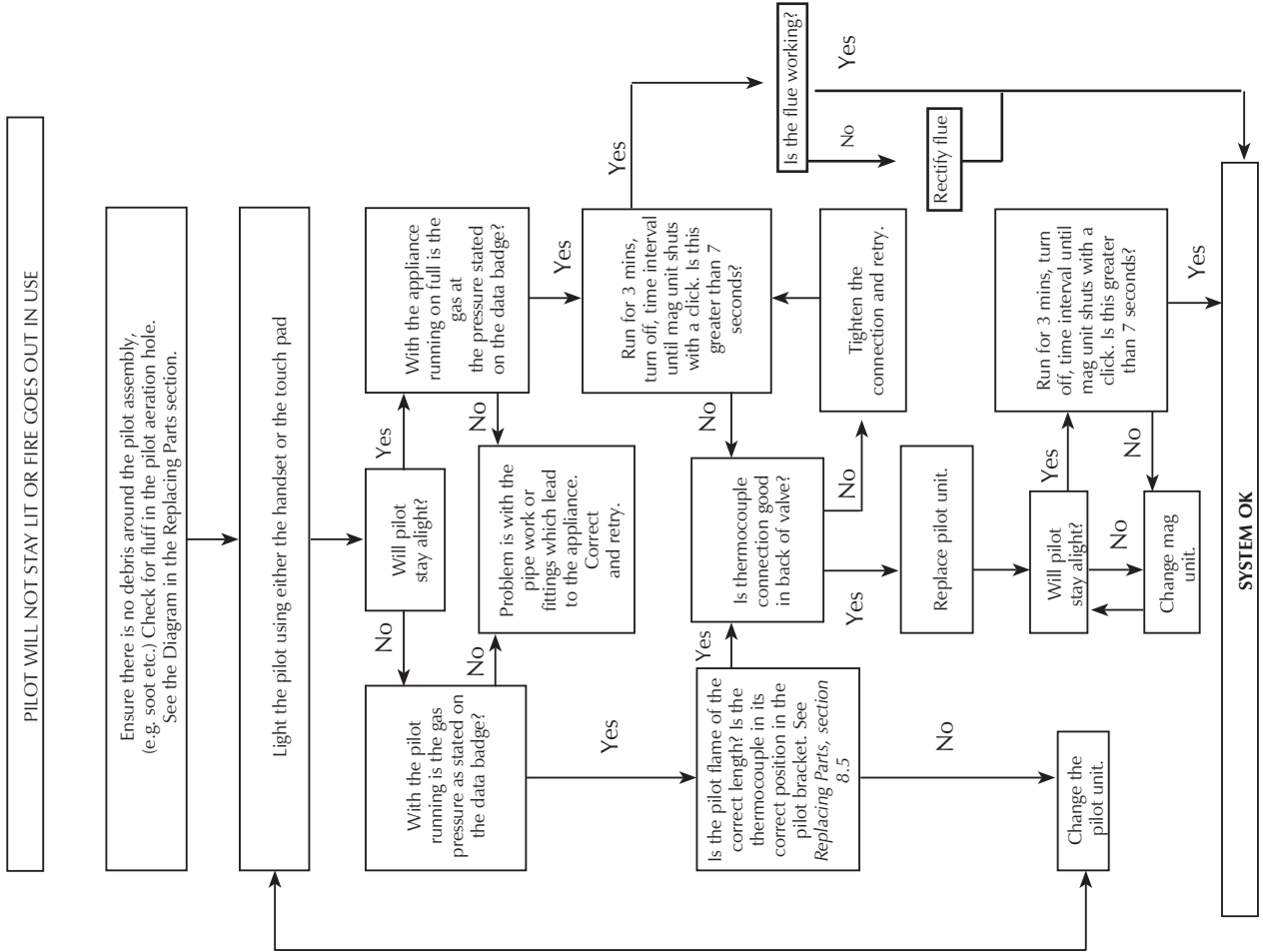

IGNITION FUNCTIONAL CHECK 2

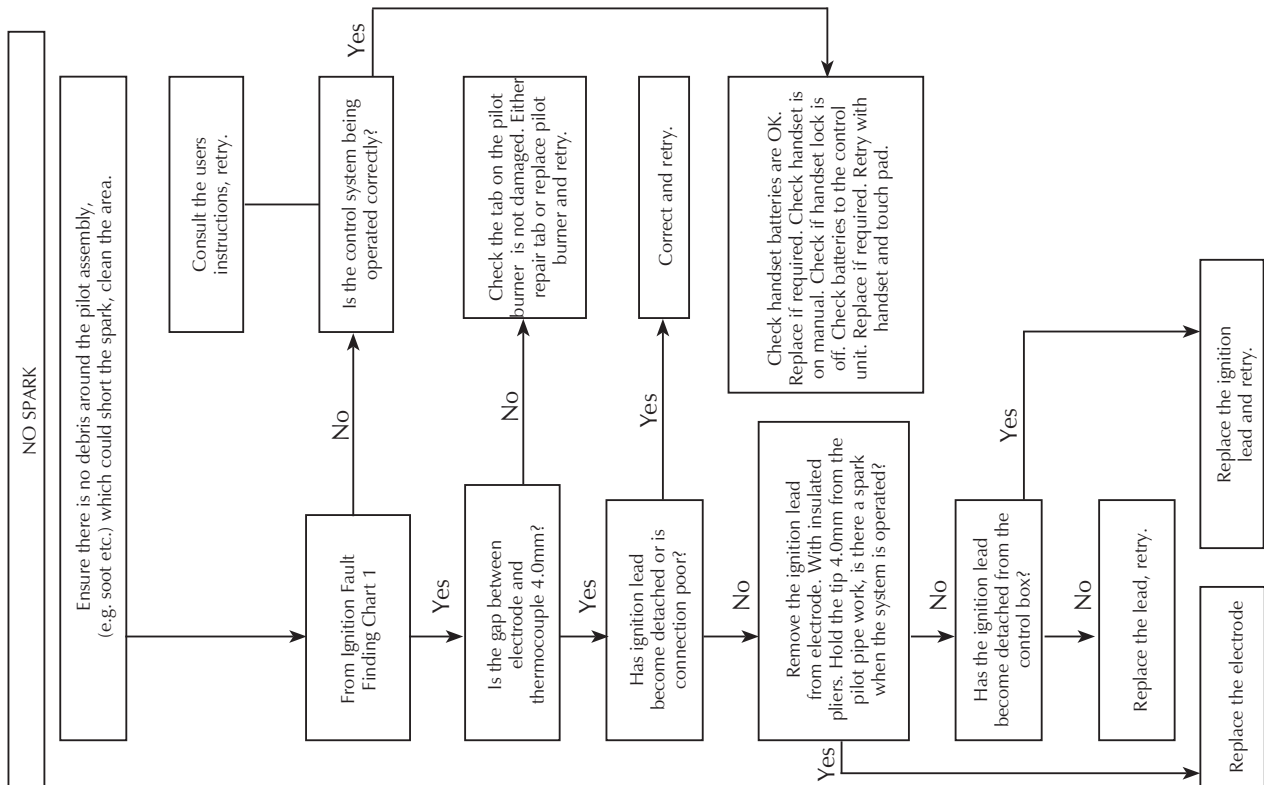

SERVICING INSTRUCTIONS

FAULT FINDING CHARTS

ELECTRONIC CONTROL VALVE FAULT ANALYSIS

Problem	Cause	Error Message	LCD Display	Solution	
Does not ignite	No batteries or flat batteries in control unit	10 beeps	BATTERY ERROR	Place new batteries in control unit	
	ROM error	2 cycles of 3 beeps	ROM ERROR	Change control unit	
	Support test error	2 cycles of 5 beeps	SUPPORT ERROR	Connect earth cable from battery box to valve	
	Bad reception of remote handset signal				Change batteries in the remote handset
					Check the reception of signal from a shorter distance
					Try pairing again
					Try changing the channel in the configuration menu
	No response to touch control buttons	If LED is continuously on, the cable is connected the wrong way round		Ensure the touch control cable is correctly connected (see installation manual)	
	Cable loose or broken or connected wrong way round			Change touch control	
Supply cable to valve disconnected or broken	2 cycles of 5 beeps	SUPPORT ERROR	Reconnect or replace valve cable		
Ignition cable disconnected or broken			Connect ignition cable		
Sparks but no pilot ignition	Gas valve supply off or no gas			Check gas installation. Open gas valve	
	Valve cable disconnected or broken			Connect valve cable correctly	
	Pilot cable disconnected or broken			Connect correctly or replace pilot cable	
Pilot ignites but does not stay on	Pilot is not warmed up			Check pilot flame and verify that it heats the pilot	
	Pilot cable badly connected			Change polarity of pilot cable	
	Pilot cable disconnected or broken			Connect pilot cable	
Ignites from remote handset but not from touch pad	Touch control cable disconnected or broken			Connect or replace touch control cable	
	Defective touch control buttons			Change touch control	
Ignites from touch pad but not from remote	Bad communication with handset			Check batteries in handset	
				Check reception of signal from a shorter distance	
				Try pairing again	
				Try changing the channel in the configuration menu	
Switches off after 6 seconds	Shortcut in touch control	5 beeps	BUTTON ERROR	Change touch control wiring	
Low batteries on remote			Low battery	Change the batteries in the remote	
Appliance switches off		2 cycles of 3 beeps	CONFIG ERROR	Change control unit	
		2 cycles of 3 beeps	EEPROM ERROR	Try pairing again Change control unit	
	Loss of communication between appliance and remote for 18min	20 beeps		The remote is too far from the appliance Replace batteries in handset	
	High temperature on control unit	1 long beep	TEMP ERROR	If this occurs more than once call the technical service	
	Ambient temperature higher than configured		Over Temperature	Check the correct configuration of safety temperature	

SERVICING INSTRUCTIONS

REPLACING PARTS

1. GENERAL

- 1.1 All main components can be replaced without removing the appliance from its installation.

IT IS ESSENTIAL THAT THE GAS SUPPLY TO THE APPLIANCE IS TURNED OFF AT THE ISOLATION DEVICE BEFORE PROCEEDING FURTHER.

- 1.2 **DISCONNECT BATTERIES BEFORE SERVICING THE APPLIANCE.**

Removal of Flue

- 1.3 **If, for any reason, the flue has to be removed from the appliance, the seal must be replaced in the inner spigot.**
- 1.4 Access to the controls is restricted and the whole control assembly must be removed as one unit (see Section 7 below).

2. DECORATIVE FRAME

The same method is used to remove each frame.

- 2.1 Lift the frame upwards off the four support brackets (see Diagram 1).

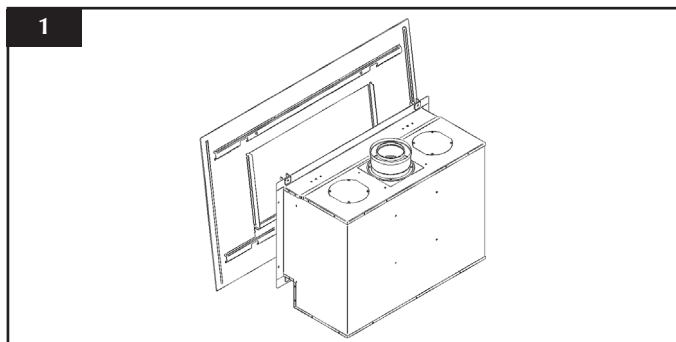

NOTE: THE STEEL FRAME IS HEAVY. TAKE CARE WHEN LIFTING.

3. WINDOW FRAME ASSEMBLY

- 3.1 To open the glass door use the hexagon key provided.
- 3.2 Release the window locks by moving them from shut to open towards the outer edges (see Diagram 2).

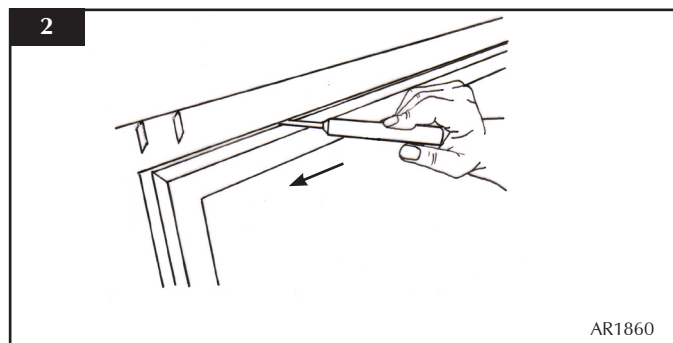

To completely remove the glass front:

- 3.3 Remove the securing spring clip from the bottom-right of the window frame (see Diagram 3).

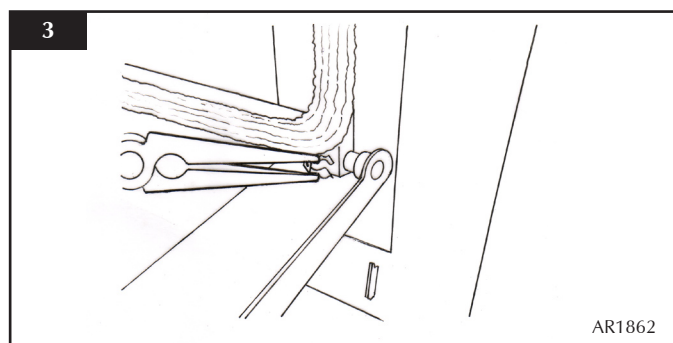

- 3.4 With the window frame in an upright position slide the frame to the left so that it comes off the left hinge pin.
- 3.5 Still keeping the frame upright drop the left side down and forward slightly (see Diagram 4).

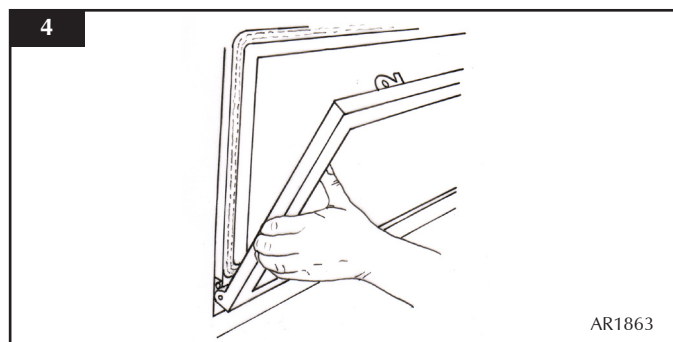

- 3.6 Slide the frame to the right so it comes off the right hinge pin. The window frame should now be free.
- 3.7 Refit in reverse order.

SERVICING INSTRUCTIONS

REPLACING PARTS

4. GLASS WINDOW

- 4.1 Remove the two clips and brackets from either side of the frame (see Diagram 5).

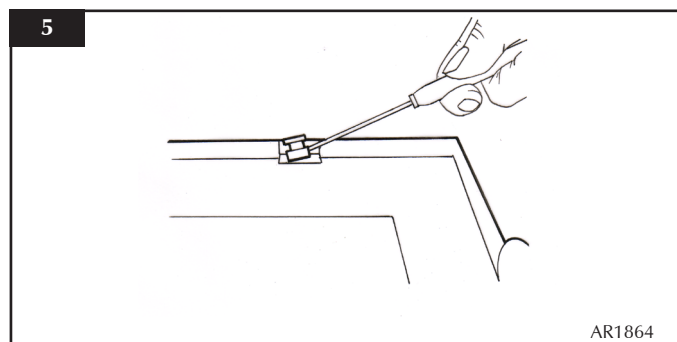

- 4.2 Lift the glass clear from the lock bracket at the top of the frame and slide out.

5. BLACK ENAMELLED PANELS

- 5.1 Hold the rear panel while sliding the side panels forward until clear of the appliance (see Diagram 6).

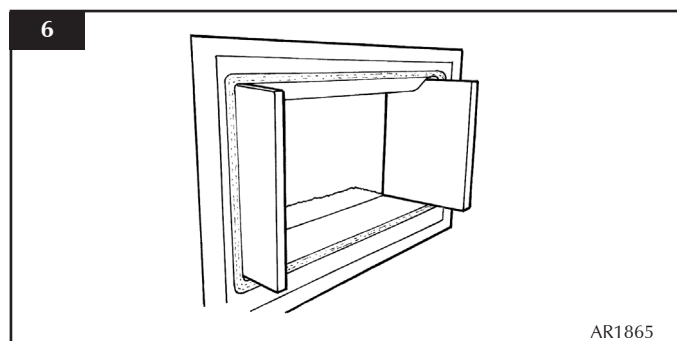

- 5.2 Lift the bottom panel out of the appliance.
- 5.3 Lift the panel from the appliance.
- 5.4 Lean the top of the rear panel forward and lift off the support rail.
- To reassemble the panels in reverse order:
- 5.5 At an angle, slide the bottom of the back panel into place before the top edge is pushed back.
- 5.6 Replace the lower panel.
- 5.7 Replace the side panels.

6. VERMICULITE PANELS FOR STUDIO WITH LOGS

NOTE: STUDIO 1 & 2 FRONT PANELS AND STUDIO 2 REAR PANELS ARE IN TWO PIECES:

HOLD THE REAR PANELS UNTIL ALL THE OTHER PANELS ARE IN PLACE AS THEY CAN FALL FORWARD.

- 6.1 Place the rear panel(s) behind the locating bracket on the rear support bar.

The Studio 1 rear panel is already in place.

- 6.2 Ensure the two-piece rear panels are centralised with the chamfers touching and pushed together (see Diagram 7).

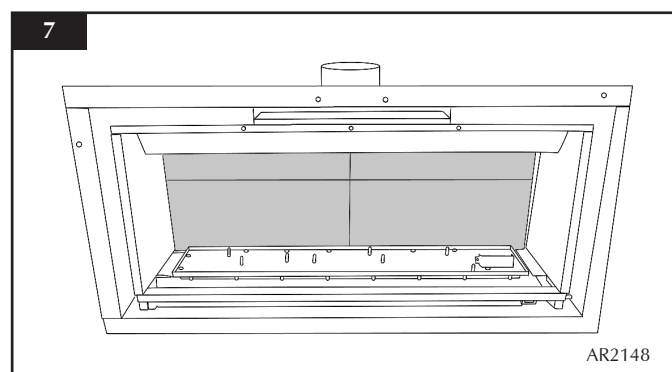

- 6.3 Place the lower side and front panels in position so the chamfers meet at the front edge of the burner.
- 6.4 Ensure the two-piece front panels are engaged against the centre support tags on the burner and are pushed together in the middle (see Diagram 8).

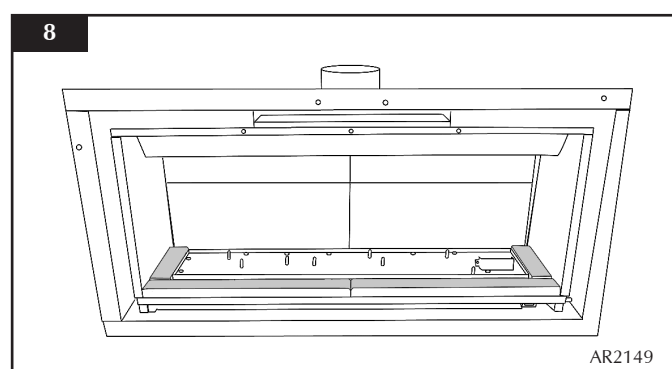

- 6.5 Slide the two side panels up to the rear panel (see Diagram 9).

SERVICING INSTRUCTIONS

REPLACING PARTS

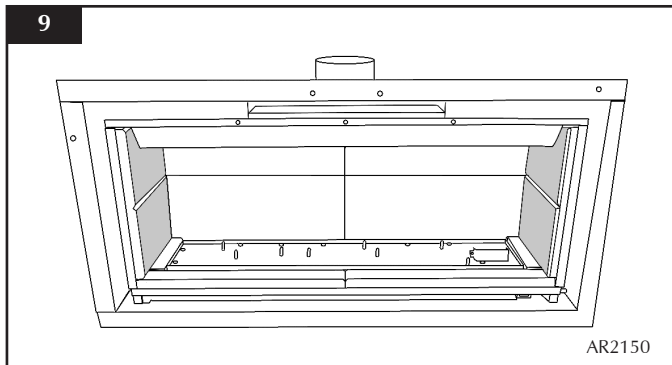

Note: THE HORIZONTAL CHAMFERS MUST ALIGN ON THE REAR AND SIDE PIECES.

6.6 Replace the side panels.

7. MAIN BURNER

To replace the main burner:

- 7.1 Remove the stone Stone Chippings from the burner (optional).
- 7.2 Remove the burner securing screw from the left side of the burner (see Diagram 10).

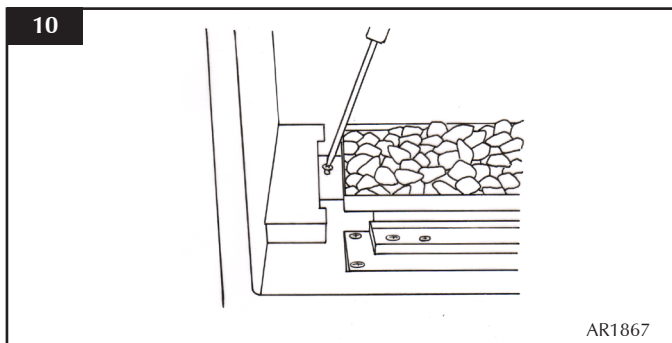

7.3 Slide the burner fully to the left.

7.4 Lift the right side clear of the pilot (see Diagram 11).

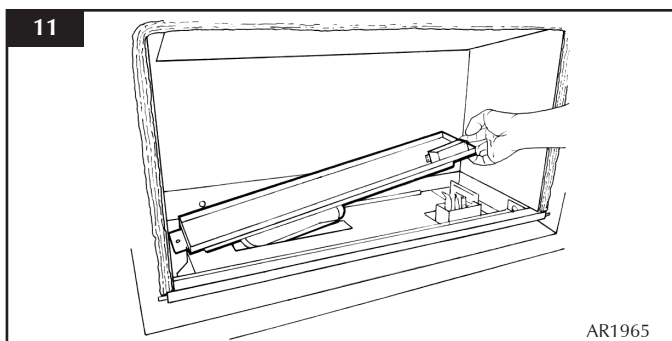

7.5 Slide the burner to the right and out of its location.

7.6 Refit in reverse order.

When refilling the Stone Chippings, fill to the rim of the burner tray and flatten until level.

Ensure no stone Stone Chippings fall into the pilot area.

8. MAIN CONTROL ASSEMBLY

8.1 To access the main control assembly first remove:

- The decorative Steel frame (if fitted)
- Window frame
- Enamelled panels
- Main burner
- Splitter plate

8.2 To remove the splitter plater:

- Loosen the fixing screws (one each side).
- Lift the front of the plate off the screws.
- Pull forward and upwards (see Diagram 12).

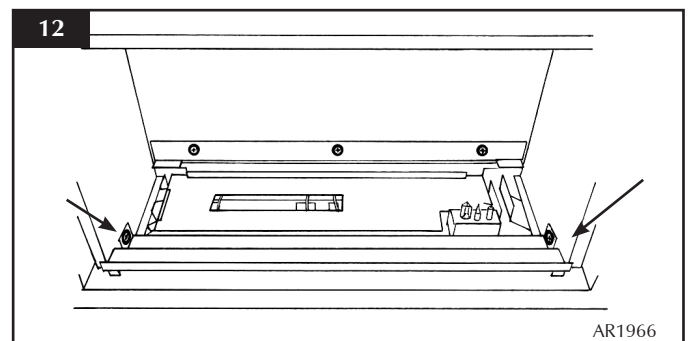

All components can be replaced without removing the control assembly.

9. PILOT UNIT ASSEMBLY

9.1 Remove the screw retaining the pilot cover (see Diagram 13).

9.2 Cut the cable tie retaining the vida flex sleeve and disconnect the ignition lead from the electrode.

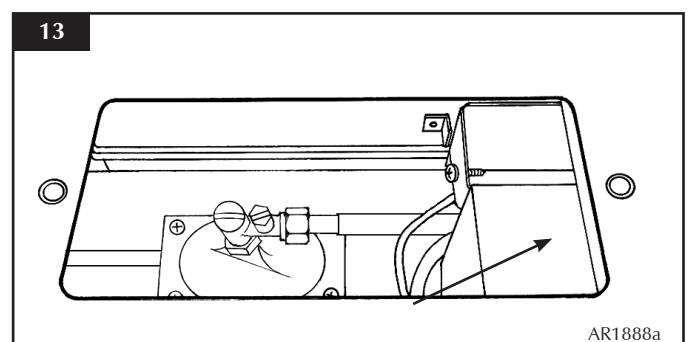

SERVICING INSTRUCTIONS

REPLACING PARTS

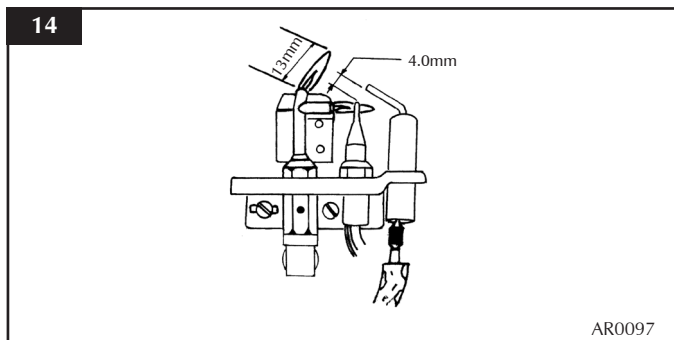

- 9.3 Undo the pilot pipe and thermocouple.
- 9.4 Remove the two fixing screws and retain the vida flex sleeve which is needed for the replacement.
- 9.5 Replace in reverse order.
- 9.6 Ensure the thermocouple and ignition lead are threaded through the vida flex and secured with a cable tie. There is a cut out in the pilot shroud to hold the vida flex.
- 9.7 Check for gas leaks.

10. IGNITION LEAD

- 10.1 Cut the cable tie securing the vida flex (if present) and disconnect the ignition lead from the electrode.
- 10.2 Pull the lead through the vida flex.
- 10.3 If necessary cut any cable ties and disconnect the lead from the control box (see Diagram 15).

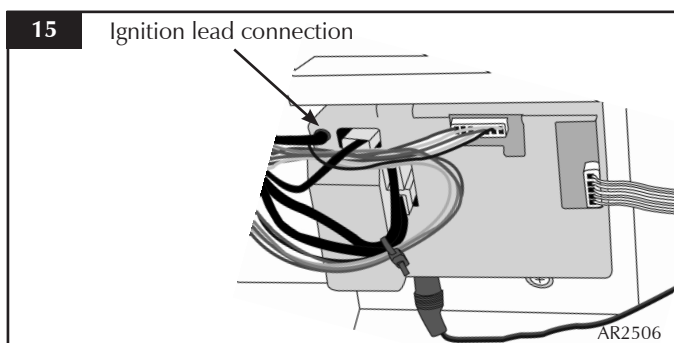

- 10.4 Replace in reverse order.
- 10.5 Ensure the lead is passed through the vida flex, secured with a cable tie and the red insulated end is attached to the electrode.

11. GAS VALVE

To change the gas valve:

- 11.1 Disconnect the gas inlet pipe.
 - 11.2 Disconnect the gas outlet pipe.
 - 11.3 Disconnect the pilot pipe.
 - 11.4 Disconnect the thermocouple, thermo current wires and the interrupter block.
- Note - make a note of the location in the interrupter block of the lead with the red tag marking.**
- 11.5 Remove the 2 x M4 nuts securing the valve to the support bracket and withdraw the valve.
 - 11.6 Disconnect the stepper motor cable plug. Push in the latching clip on the plug to withdraw (see Diagram 16).

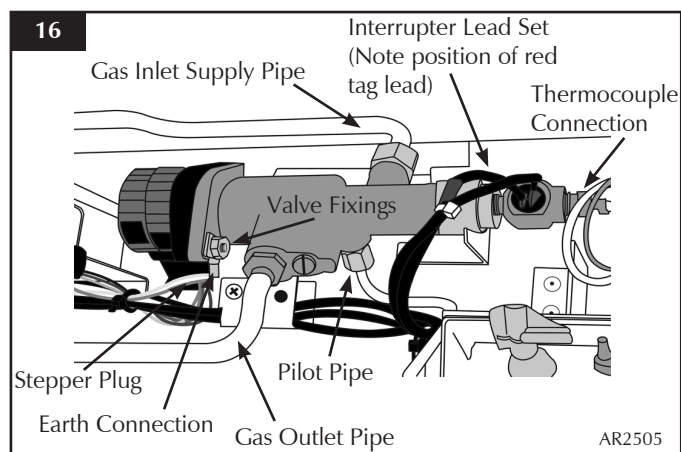

Replace in reverse order ensuring:

- 11.7 The earth cable ring tag is positioned between the valve body and the bracket.
- 11.8 The interrupter leads are connected correctly with the red tag lead nearest to the gas valve body.

SERVICING INSTRUCTIONS

REPLACING PARTS

12. MAGNETIC SAFETY VALVE

To replace the magnetic safety valve:

- 12.1 Undo the thermocouple from the interrupter block and remove the two thermo current cables.
- 12.2 Unscrew the interrupter block from the back of the valve.
- 12.3 Undo the silver magnetic valve retaining nut on the back of the valve.
- 12.4 Gently tap out the mag valve.
- 12.5 Replace with a new unit.
- 12.6 Reassemble in reverse order ensuring that the interrupter leads are connected correctly with the red tag lead nearest to the gas valve body.
- 12.7 Check for leaks.

13. CONTROL BOX

- 13.1 Disconnect from the control box:

- Ignition lead
- Thermo current cables
- Earth connection
- 7-way stepper motor plug
- The battery power supply cable
- The touch pad control cable

Refer to Diagram 17 for details.

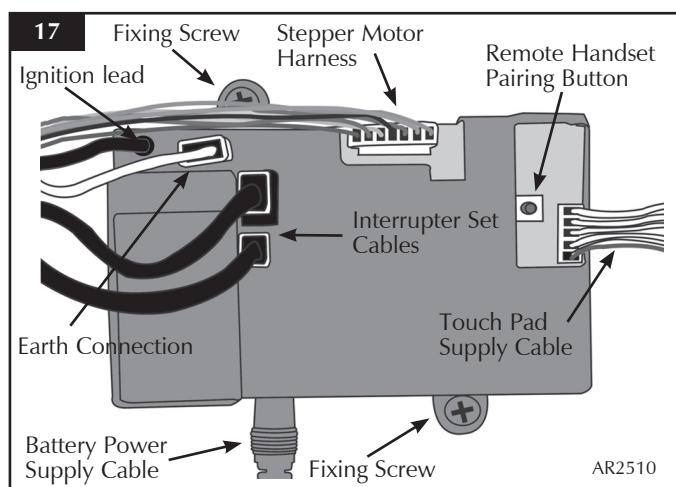

- 13.2 Undo the two screw fixings holding the PCB box (see Diagram 17). The control box can now be replaced.
- 13.3 After replacing the control box ensure all cables connections are refitted as detailed in Diagram 18.

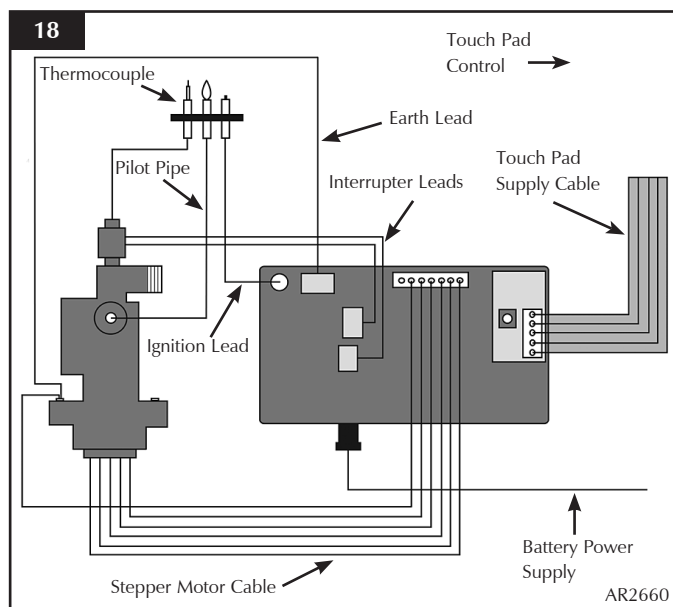

- 13.4 Prior to re-connection of the control box to the appliance, if there is no communication between the remote handset and the appliance, or if the handset is replaced, it will be necessary to pair the (new) handset with the appliance.
 - 13.5 Ensure batteries are fitted and working in the handset.
 - 13.6 Re-fit the touch pad control cable and the battery power supply cable to the control box.
 - 13.7 Press the ON/OFF button for 40 seconds until the configuration screen appears.
 - 13.8 When the configuration menu screen appears ensure the Pairing option is set to ON using the Change button.
 - 13.9 Within 20 seconds press the yellow button on the control unit (see Diagram 17). This may be easier using a pencil, ball point pen or similar.
 - 13.10 The control will emit a single beep to confirm the pairing operation and the remote handset will display a signal level in the top right hand corner.
- If there are any difficulties achieving pairing ensure that the handset is set to Channel A. To do this follow the steps below:**
- 13.11 Press the ON/OFF button for 40 seconds until the configuration screen appears.
 - 13.12 Scroll down the menu using the (↓) button and select Channel A.

SERVICING INSTRUCTIONS

REPLACING PARTS

13.13 Ensure the Pairing option is set to ON using the Change button.

13.14 Disconnect the batteries from the control box and reconnect after 10 seconds.

13.15 The motor on the valve will turn. Once it has stopped repeatedly press and release the yellow button on the control box until the control box emits a single beep to confirm the pairing operation has been successful.

14. MAIN INJECTOR

To change the main injector:

14.1 Undo the injector feed pipe.

14.2 Undo the lock nut from the injector and remove the silencer.

14.3 Replace with the correct size injector.

14.4 Check for leaks.

15. PRIMARY AERATION PLATE

NOT ALL MODELS HAVE AERATION PLATES. REFER TO TECHNICAL SPECIFICATIONS, PAGES 14 & 15.

15.1 Remove the burner module as described in *Replacing Parts Section 6*.

15.2 Remove the fixing screw and slide the plate off the venturi.

15.3 Replace with the correct size plate and secure with the screw. Ensure the lower edge of the plate is located over the venturi flange (see Diagram 19).

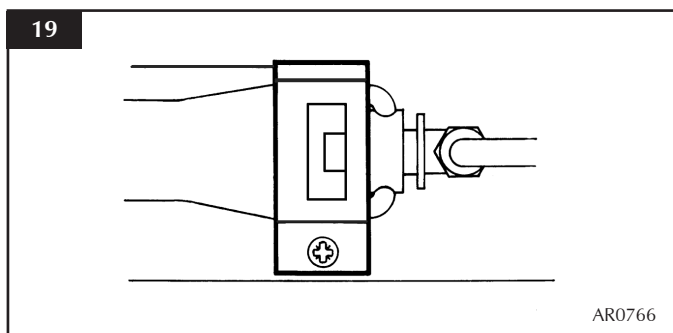

16. DEBRIS AREA ACCESS

16.1 Remove the Steel frame (if fitted).

16.2 Remove the glass door assembly.

16.3 Remove the enamelled panels.

16.4 Remove the burner and splitter plate.

16.5 Isolate the gas supply.

16.6 Disconnect the isolating device from the inlet pipe on the appliance.

16.7 Remove the seven screws from the front of the loose box (see Diagram 20).

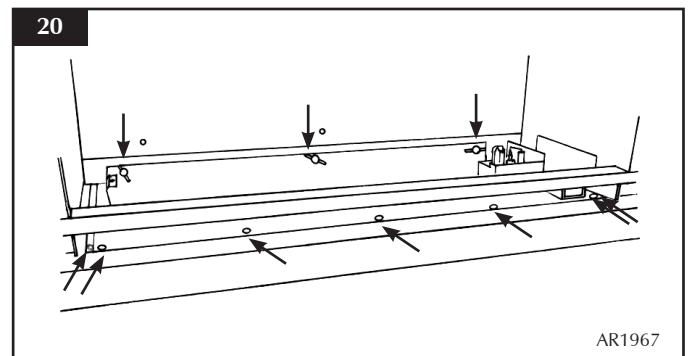

16.8 Remove the three screws from the rear panel.

16.9 Lift the panel to disengage the locating brackets (see Diagram 20).

16.10 Remove the three wing nuts and screws retaining the loose box (see Diagram 20).

To release the box from the main body:

16.11 Rotate the front of the box upwards and draw the box forward off the rear studs.

16.12 Ensure the gas pipe passes through the silicon seal in the base of the box.

Any debris can now be removed through the aperture.

16.13 Replace in reverse order taking care not to damage the gas pipe when replacing the box.

SERVICING INSTRUCTIONS

REPLACING PARTS

17. CHANGING BETWEEN GAS TYPES

In order to change between gas types, it will be necessary to change the both the burner assembly and the complete control assembly.

Contact your Gazco dealer for further information.

A kit of parts is available for this, always quote the Model number and Serial number when ordering any spare parts.

18. PRESSURE AND LEAK TESTING THE APPLIANCE

- 18.1 Follow Section 8, Main Control Assembly.
- 18.2 Access to the pressure test point can now be reached (see Diagram 21).

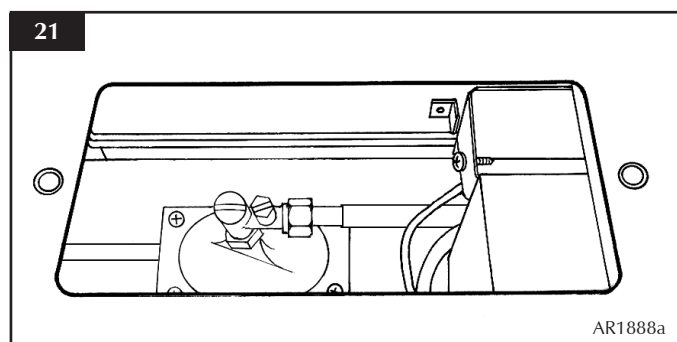

- 18.3 Refer to Installation Instructions, Section 7.48 to check gas pressure
- 18.4 Light the appliance and spray any joints with leak detector fluid.
- 18.5 Tighten joints or replace as required.
- 18.6 To check the inlet working pressure, replace the control assembly and connect a manometer to the pressure test point as depicted in Diagram 21. Replace the burner and relight the appliance. Operate the appliance at highest flame setting and check that the inlet pressure is in accordance with specifications detailed on page 14 & 15.

SERVICING INSTRUCTIONS

REPLACING PARTS

19. SHORT SPARES LIST

STONE CHIPPINGS VERSIONS

COMPONENT	STUDIO 1 CF		STUDIO 2 CF	
	NG	LPG	NG	LPG
PILOT	PI0036	PI0037	PI0036	PI0037
MAIN INJECTOR	IN0028	IN0040	IN0029	IN0041
BURNER ASSEMBLY	GZ6714	GZ6759	GZ6861	GZ6860
AERATION PLATE	G20 - GZ3869	G30 - N/A	G20-GZ3868	G30 - N/A
	G25 - GZ4333	G31 - N/A	G25 - GZ3270	G31 - GZ3866
MAG UNIT	GC0109		GC0109	
IGNITION LEAD	EL0508		EL0508	
GAS VALVE	GC0107		GC0107	
CONTROL BOX	EL0506	EL0516	EL0506	EL0507
REMOTE CONTROL	EL0500		EL0500	
INTERRUPTER BLOCK	GC0026		GC0026	
THERMO CURRENT CABLE	EL0499		EL0499	
TOUCH PAD /WALL PLATE ASSEMBLY	EL0501		EL0501	
TOUCH PAD LEAD	EL0502		EL0502	
BATTERY HOLDER	EL0503		EL0503	
BATTERY HOLDER CABLE	EL0504		EL0504	
CONTROL BOX/VALVE CABLE	EL0505		EL0505	
REAR ENAMELLED PANEL	GZ6488		GZ6867	
SIDE ENAMELLED PANEL	GZ6489		GZ6489	
BASE ENAMELLED PANEL	GZ6490		GZ6866	
STONE Stone Chippings	CE0647		CE0579	

SERVICING INSTRUCTIONS

REPLACING PARTS

20. SHORT SPARES LIST

LOG VERSIONS

COMPONENT	STUDIO 1 CF		STUDIO 2 CF	
	NG	LPG	NG	LPG
PILOT INJECTOR	PI0036	PI0037	PI0036	PI0045
MAIN INJECTOR	IN0045	IN0068	IN0029	IN0058
BURNER ASSEMBLY	GZ7007	GZ7540	GZ7545	GZ7436
AERATION PLATE	G20 - GZ3869	G31 - GZ3869	G20 - GZ2016	G31 - GZ5427
ELECTRODE	PI0075		PI0075	
MAG UNIT	GC0109		GC0109	
IGNITION LEAD	EL0508		EL0508	
GAS VALVE	GC0107		GC0107	
CONTROL BOX	EL0506	EL0516	EL0506	EL0507
REMOTE CONTROL	EL0500		EL0500	
INTERRUPTOR BLOCK	GC0026		GC0026	
THERMOCURRENT CABLE	EL0499		EL0499	
TOUCH PAD /WALL PLATE ASSEMBLY	EL0501		EL0501	
TOUCH PAD LEAD	EL0502		EL0502	
BATTERY HOLDER	EL0503		EL0503	
BATTERY HOLDER CABLE	EL0504		EL0504	
CONTROL BOX/VALVE CABLE	EL0505		EL0505	
LINER BASE SIDE PIECE (2 PER APPLIANCE)	CE0673		CE0673	
LINER BASE FRONT L/H PIECE	CE0677		CE0689	
LINER BASE FRONT R/H PIECE	CE0706		CE0707	
LINER BACK PANEL	CE0678		N/A	
LINER SIDE PANEL (2 PER APPLIANCE)	CE0679		CE0679	
LINER BACK PANEL L/H SIDE	N/A		CE0690	
LINER BACK PANEL R/H SIDE	N/A		CE0727	
VERMICULITE	CE0745		CE0746	
LOG SET	CE0696		CE0729	

SERVICE RECORDS

1ST SERVICE

Date of Service:.....
Next Service Due:.....
Signed:.....
Dealer's Stamp/Gas Safe Registration Number

2ND SERVICE

Date of Service:.....
Next Service Due:.....
Signed:.....
Dealer's Stamp/Gas Safe Registration Number

3RD SERVICE

Date of Service:.....
Next Service Due:.....
Signed:.....
Dealer's Stamp/Gas Safe Registration Number

4TH SERVICE

Date of Service:.....
Next Service Due:.....
Signed:.....
Dealer's Stamp/Gas Safe Registration Number

5TH SERVICE

Date of Service:.....
Next Service Due:.....
Signed:.....
Dealer's Stamp/Gas Safe Registration Number

6TH SERVICE

Date of Service:.....
Next Service Due:.....
Signed:.....
Dealer's Stamp/Gas Safe Registration Number

7TH SERVICE

Date of Service:.....
Next Service Due:.....
Signed:.....
Dealer's Stamp/Gas Safe Registration Number

8TH SERVICE

Date of Service:.....
Next Due:.....
Signed:.....
Dealer's Stamp/Gas Safe Registration Number

9TH SERVICE

Date of Service:.....
Next Service Due:.....
Signed:.....
Dealer's Stamp/Gas Safe Registration Number

10TH SERVICE

Date of Service:.....
Next Service Due:.....
Signed:.....
Dealer's Stamp/Gas Safe Registration Number

Gazco Limited, Osprey Road, Sowton Industrial Estate, Exeter, Devon, England EX2 7JG
Tel: (01392) 261999 Fax: (01392) 444148 E-mail: info@gazco.com

A member of the Stovax Group