

GAZCO



Riva 53/67 Inset Convectector Fire Conventional Flue

Instructions for Use, Installation and Servicing

For use in GB, IE (Great Britain and Eire)

This appliance has been certified for use in countries other than those stated. To install this appliance in these countries, it is essential to obtain the translated instructions and in some cases the appliance will require modification. Contact Gazco for further information.

IMPORTANT

Do not attempt to burn rubbish in this appliance. This appliance must only be operated with the glass door secured firmly in position. The front casing of this appliance will become hot whilst in operation, it is therefore recommended that a suitable guard should be used for the protection of young children, the elderly or infirm.

**Please read these Instructions carefully before installation or use.
Keep them in a safe place for future reference and when servicing the fire.**

The commissioning sheet found at the end of the Users Sections of these instructions should be completed by the Installer.

COVERING THE FOLLOWING MODELS

8590LUC P8590LUC
8596 P8596

CONTENTS

	PAGE
APPLIANCE COMMISSIONING CHECKLIST	3
USER INSTRUCTIONS	4
INSTALLATION INSTRUCTIONS	10
Technical Specifications	10
Site Requirements	11
Installation	14
Commissioning	22
SERVICING INSTRUCTIONS	23
Servicing Requirements	23
Fault Finding	23
How to replace parts	25
Basic spare parts list	32
Service Records	33

APPLIANCE COMMISSIONING CHECKLIST

IMPORTANT NOTICE

Explain the operation of the appliance to the end user, hand the completed instructions to them for safe keeping, as the information will be required when making any guaranteed claims.

FLUE CHECK	PASS	FAIL
1. Flue is correct for appliance		
2. Flue type (delete as appropriate)	Lined	Debris Kit
3. Flue flow test		
4. Spillage test		
GAS CHECK		
1. Gas soundness & let by test		
2. Standing pressure test	mb	
3. Appliance working pressure (on High Setting) NB All other gas appliances must be operating on full	mb	
4. Gas rate	m ³ /h	
5. Does ventilation meet appliance requirements		
6. Have controls been upgraded (Upgradeable models only)	8455 Standard YES	NO
	8456 Programmable Thermostatic and Timer YES	NO

DEALER AND INSTALLER INFORMATION

Dealer.....

.....

.....

Contact No.

Date of Purchase.....

Model No.....

Serial No.....

Gas Type.....

Installation Company.....

.....

.....

Engineer

Contact No.....

Corgi Reg No.....

Date of Installation.....

This product is guaranteed for 2 years from the date of installation, as set out in the terms and conditions of sale between Gazco and your local Gazco dealer. **This guarantee will be invalid, to the extent permitted by law, if the above Appliance Commissioning Checklist is not fully completed by the installer and available for inspection by a Gazco engineer.** The guarantee will only be valid during the second year, to the extent permitted by law, if the annual service recommended in the Instructions for Use has been completed by a Corgi registered engineer, and a copy of the service visit report is available for inspection by a Gazco engineer.

USER INSTRUCTIONS

1. GENERAL

- 1.1 A competent person must carry out installation and servicing.
- 1.2 In all correspondence, please quote the appliance type and serial number, which can be found on the databadge located on a plate under the appliance.
- 1.3 Ensure that curtains are not positioned above the appliance and there is at least 300mm between the sides of the appliance and any curtains.
- 1.4 If any cracks appear in the glass panel do not use the appliance until the panel has been replaced.
- 1.5 This product is guaranteed for 2 years from the date of installation, as set out in the terms and conditions of sale between Gazco and your local Gazco dealer. Please consult your local Gazco dealer if you have any questions. In all correspondence always quote the Model Number and Serial Number.

2. LIGHTING THE RIVA

- 2.1 Locate the control valve on the appliance. There are two control knobs on the valve, the right-hand knob controls the pilot ignition and the left-hand knob controls the main burner.

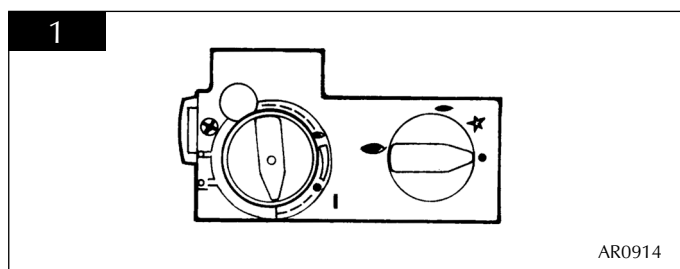

- 2.2 If your appliance has already been upgraded to battery remote control, please refer to the instructions provided with the upgrade to operate the remote control. The following instructions will work for either situation.
- 2.3 Ensure that the left-hand control knob is pointing to off (●).
- 2.4 Ensure that the right-hand control knob is pointing to off (●).
- 2.5 Press in the right-hand control knob and rotate it anticlockwise until a click is heard (keep pressing in) and the knob is pointing to pilot (★). The pilot should now light. If the pilot has not lit, repeat the procedure until it does.
- 2.6 Keep the control knob pressed for 10 seconds and then release it, the pilot should stay alight. If the pilot goes out, repeat the procedures until it does.
- 2.7 If the pilot will not light after repeated attempts, contact the retailer or installer from whom the appliance was purchased.
- 2.8 Turn the right-hand control to point to main burner (☹). The appliance can now be controlled using the left-hand control knob.

- 2.9 Turn the left-hand control knob to point to low fire (☹), the main burner will light on low. The burner can now be controlled between low and high settings. Turn the control knob anticlockwise to increase the flame height and clockwise to decrease the flame height.

THE YELLOW FLAMES WILL APPEAR WHEN THE FIRE HAS GAINED SUFFICIENT HEAT - TYPICALLY 10 TO 20 MINUTES.

3. TURNING THE RIVA OFF

- 3.1 To turn the Riva off, locate the control valve, turn the left-hand control knob until it points to off (●). The main burner will go out leaving the pilot burning.
- 3.2 To turn the pilot off, locate the control valve, turn the right-hand control knob until it points to off (●), the pilot will go out.

IF THE FIRE IS EXTINGUISHED OR GOES OUT IN USE, WAIT 3 MINUTES BEFORE ATTEMPTING TO RELIGHT THE FIRE. THE CONTROL VALVE HAS AN INTERLOCK DEVICE AND THEREFORE CANNOT BE LIT UNTIL THE 3 MINUTES HAVE ELAPSED.

4. UPGRADING YOUR RIVA

- 4.1 Your Riva is fitted with a control valve that can easily be upgraded to battery powered remote control. This upgrade can be fitted by anyone capable of simple DIY jobs and requires no special training. There are two versions of this control which can be obtained through your local Gazco stockist.
- 4.2 **STANDARD REMOTE CONTROL** This remote control can control the gas appliance after the pilot has been lit. It can turn the main burner on and regulate it from low through to high and back again. It can turn the main burner off leaving the pilot burning. GAZCO PART NUMBER 8455.
- 4.3 **PROGRAMMABLE THERMOSTATIC AND TIMER REMOTE CONTROL** This remote control can control the gas appliance after the pilot has been lit. In 'MANUAL MODE' it can be used to turn the main burner on and manually regulate it from low through to high and back again. It can also be used to turn the main burner off leaving the pilot burning. In 'AUTO MODE' it will automatically regulate the room temperature to a pre-set temperature. In 'TIMER MODE' it will turn the fire on and off according to a pre-set programme and automatically regulate the room temperature during the two on periods. GAZCO PART NUMBER 8456.

USER INSTRUCTIONS

5. CLEANING THE RIVA

ADVICE ON HANDLING AND DISPOSAL OF FIRE CERAMICS

The fuel effect and side panels in this appliance are made from Refractory Ceramic Fibre (RCF), a material which is commonly used for this application.

Protective clothing is not required when handling these articles, but we recommend you follow normal hygiene rules of not smoking, eating or drinking in the work area and always wash your hands before eating or drinking.

To ensure that the release of RCF fibres are kept to a minimum, during installation and servicing a HEPA filtered vacuum is recommended to remove any dust accumulated in and around the appliance before and after working on it. When servicing the appliance it is recommended that the replaced items are not broken up, but are sealed within heavy duty polythene bags and labelled as RCF waste.

RCF waste is classed as stable, non-reactive hazardous waste and may be disposed of at a licensed landfill site.

Excessive exposure to these materials may cause temporary irritation to eyes, skin and respiratory tract; wash hands thoroughly after handling the material.

- 5.1 Remove the Profil frame from the appliance by removing the 2 concealed screws behind the lower access door. See diagram 2. Pull the frame forward at the bottom then lift clear of the top fixing lugs.

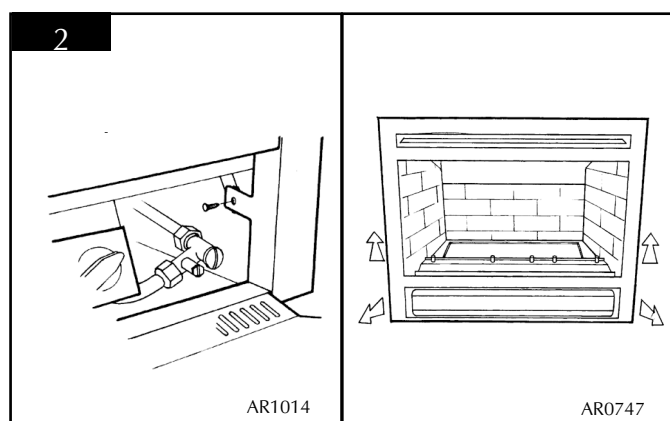

Note: If the appliance is fitted with an alternative Gazco Riva front, please refer to the separate leaflet supplied with the front.

- 5.2 Remove the glass door by unscrewing the six screws. See diagram 3, arrow A.

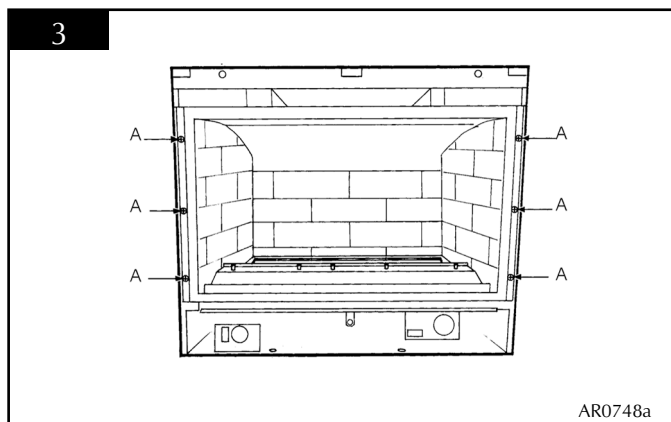

- 5.3 Remove the ceramic logs and granules, and place them on a dry, clean surface.
- 5.4 The logs should not require cleaning. Do not use a vacuum cleaner or brush to clean the logs, any large pieces of debris may be removed by hand.
- 5.5 Ensure any debris is removed from the burner ports.
- 5.6 Replace the ceramics by referring to section 6.
- 5.7 Use a damp cloth to clean the outer casing of the appliance.

6. ARRANGEMENT OF FUEL BED COMPONENTS

RIVA 67

THE BAG OF GRANULES CONTAINED IN THE LOG SET IS TO SIMULATE AN ASH EFFECT. THIS IS NOT TO BE PLACED ON THE BURNER.

- 6.1 Place some of the granules around the rear and sides of the burner tray. **ENSURE NO GRANULES FALL ON THE BURNER.** See diagram 4.

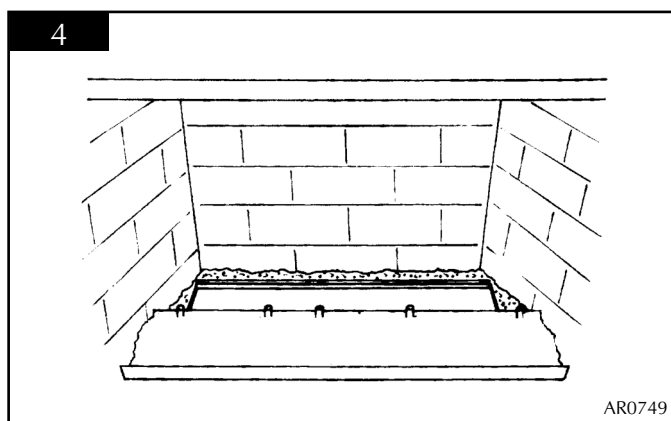

USER INSTRUCTIONS

- 6.2 Place log 1 (large black log) on the burner. Ensure the rear of the log touches the rear of the burner. See diagram 5.

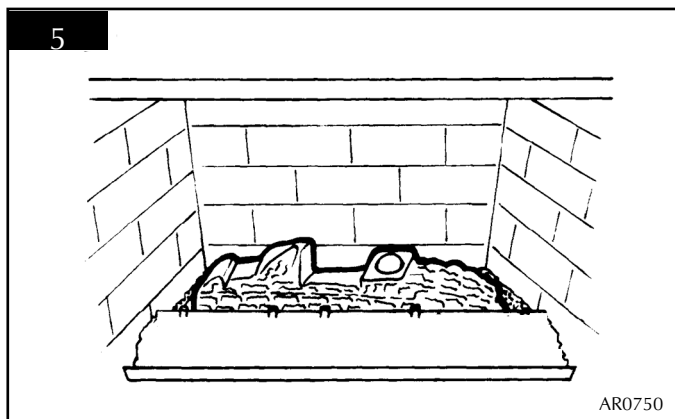

CENTRALISE THE LOG BETWEEN THE BURNER PORTS AT EITHER END.

ALL THE REMAINING LOGS EXCEPT FOR THE SMALLEST ONE HAVE LOCATION HOLES ON THE UNDERSIDE, THESE LOCATE ON THE STUDS AT THE FRONT OF THE FIRE.

- 6.3 Place log 2 on the centre and locate the rear of the log on the large flat area of log 1. See diagram 6.

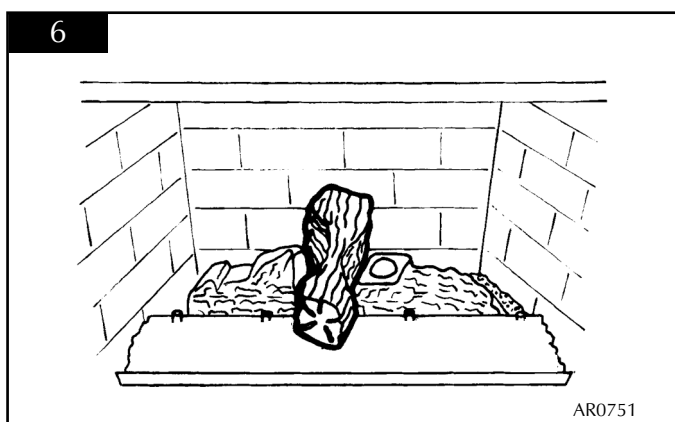

- 6.4 Place log 3 on the far left-hand stud. The recess on the underside of the log should locate on the top of log 1 on the far left-hand side. See diagram 7.

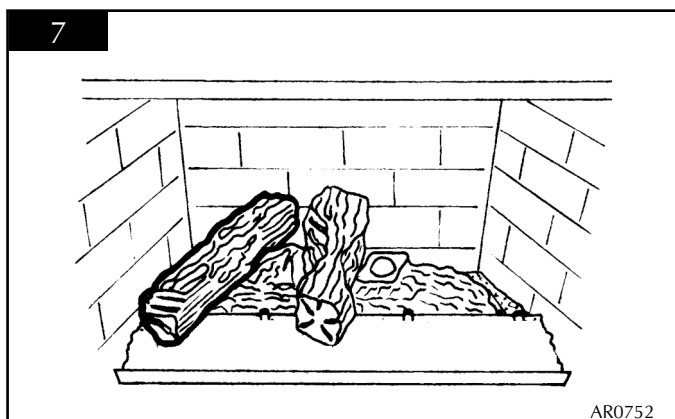

- 6.5 Place log 4 on the right-hand side of the centre log. There is a large recess on the underside of the log, which is located on log 1. See diagram 8.

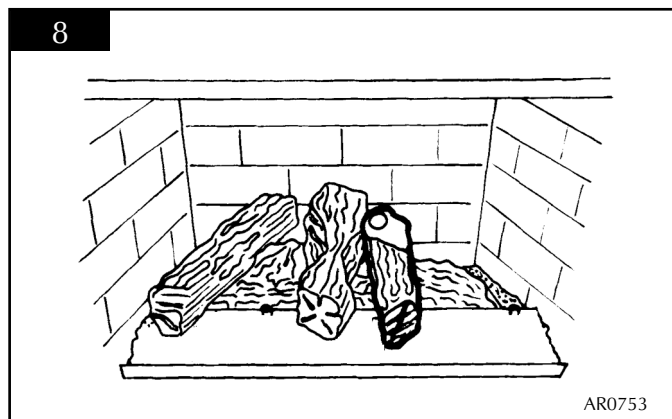

- 6.6 Place log 5 on top of log 4 and ensure the two large locations engage. Locate the front of the log on to the far right-hand stud. See diagram 9.

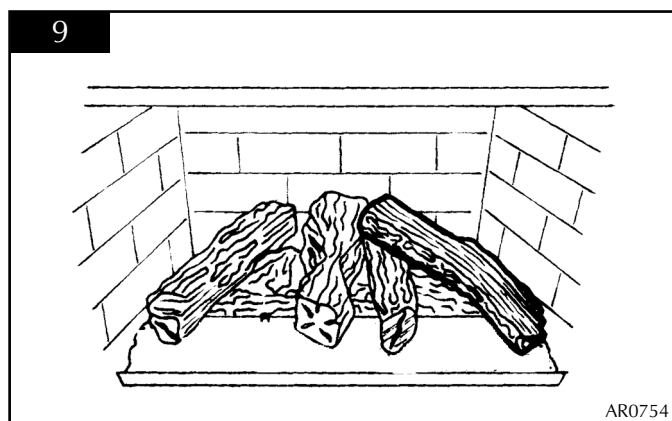

- 6.7 Place log 6 on the remaining stud and lean the log on to log 1 between logs 2 and 3. There is a notch to locate the log. See diagram 10.

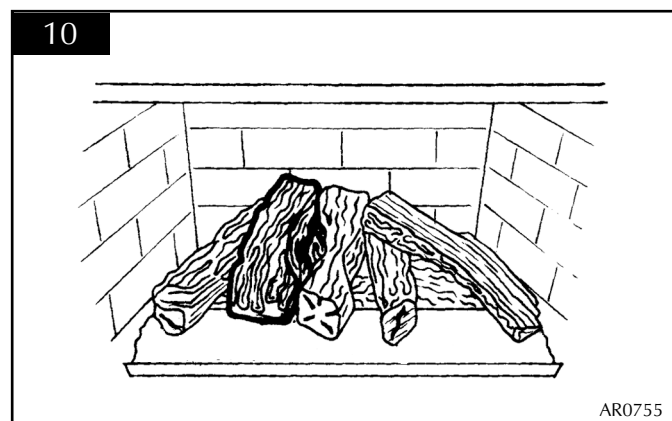

USER INSTRUCTIONS

- 6.8 Place log 7 at the front of the fire between logs 4 and 5. **DO NOT PLACE THIS LOG ON THE BURNER. IT IS ONLY TO FILL THE GAP BETWEEN LOGS 4 AND 5.** The charred effect should face the rear of the fire. Place the remaining granules between the logs so that they cover the front metal ledge. See diagram 11. **ENSURE NO GRANULES FALL ON THE BURNER.**

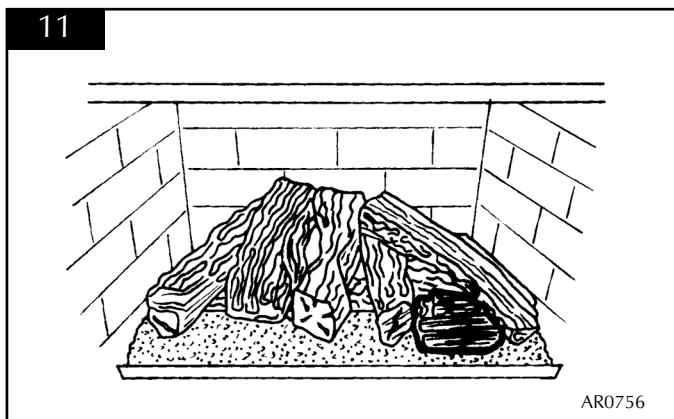

RIVA 53

- 6.9 Place log A on to the burner. Ensure the rear of the log touches the rear burner. See diagram 12.

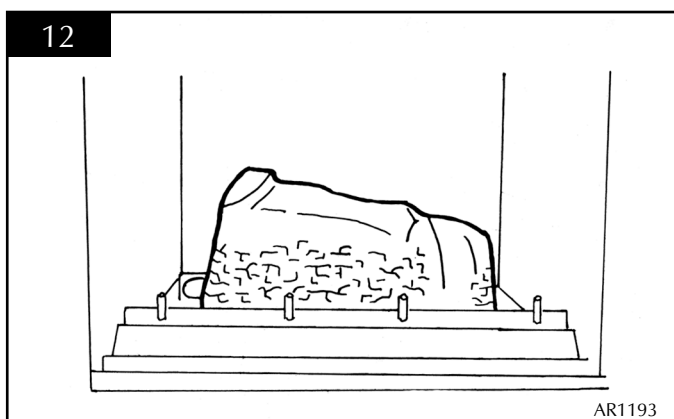

CENTRALISE THE LOG BETWEEN THE BURNER PORTS AT EITHER END.

Four of the remaining logs have location holes on the underside. These locate on the studs at the front of the fire

- 6.10 Place log D on the third stud from the left and resting at the rear on log A. See diagram 13.

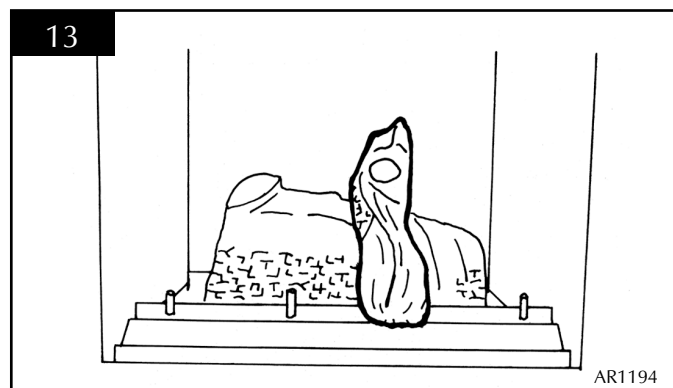

- 6.11 Place log C on the second stud resting at the rear on log A. See diagram 14.

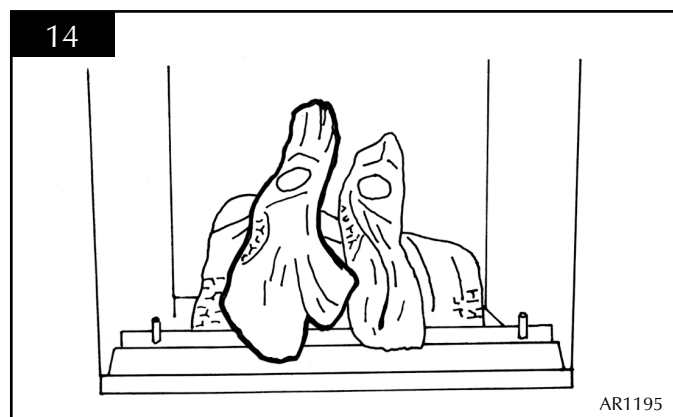

- 6.12 Place log B on the first stud. The recess on the underside of the log should locate on the top of log C. See diagram 15

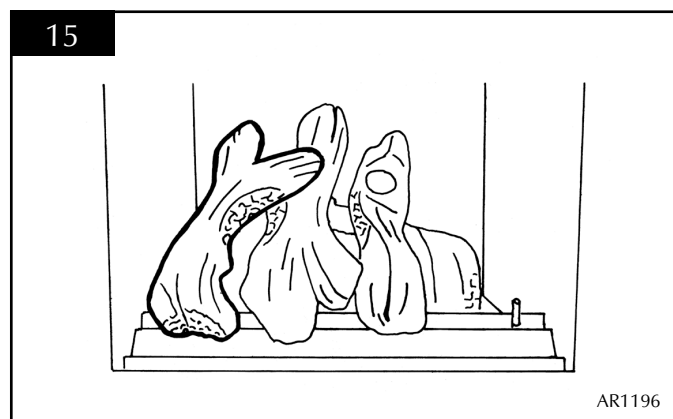

USER INSTRUCTIONS

- 6.13 Place log E on the last stud. The recess on the underside of the log should locate on to the top of log D. See diagram 16.

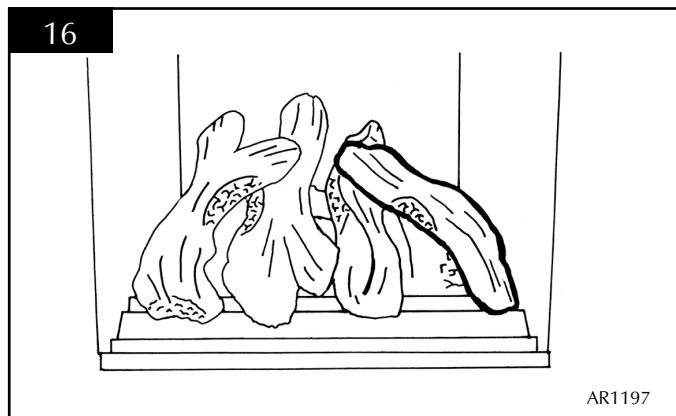

- 6.14 Place log F on the rear tray and leaning forward to locate in the recess in log E. See diagram 17.

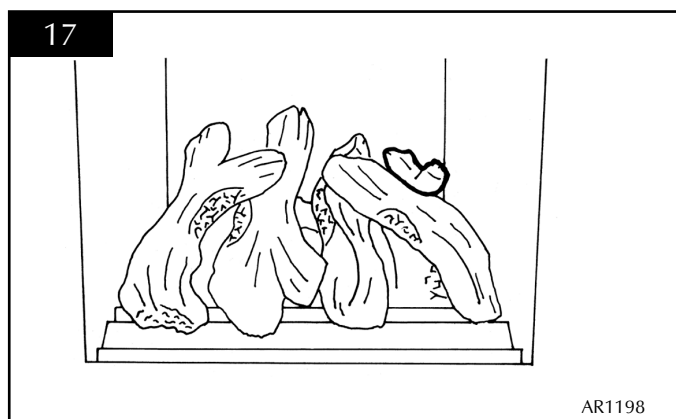

- 6.15 Place log G at the front of the fire between logs D and E. **DO NOT PLACE THIS LOG ON THE BURNER. IT IS ONLY TO FILL THE GAP BETWEEN LOGS D AND E.** The charred effect should face the rear of the fire. See diagram 18.

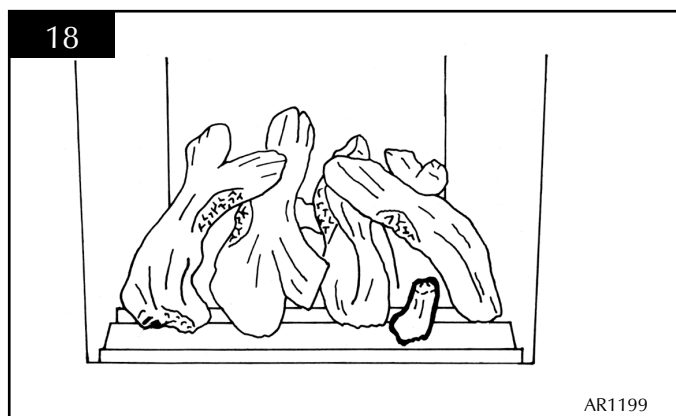

- 6.16 With the granules fill the front compartment around the logs evenly. **ENSURE NO GRANULES FALL ON THE BURNER.** See diagram 19.

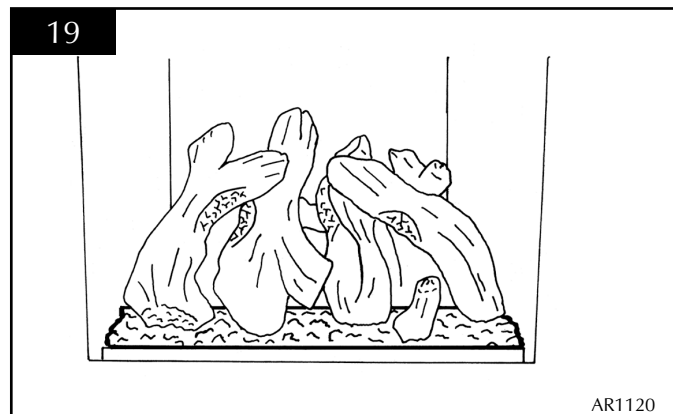

- 6.17 **NOTE: ENSURE THAT THE LOGS ARE POSITIONED AS ABOVE. ONLY USE THE CORRECT AMOUNT OF LOGS AS SPECIFIED IN THE DIAGRAMS.**
- 6.18 Ensure that the fibreglass seal on the back of the glass frame is intact then hook the location tabs over the hooks on the top of the firebox. Replace the six screws working from the top down. Tighten the screws evenly. **DO NOT OVER TIGHTEN.**
- NEVER OPERATE THE APPLIANCE WHEN THE GLASS PANEL IS REMOVED OR BROKEN.**
- 6.19 Replace the Profil frame by hooking the top over the location lugs on top of the flanges, replace the two fixing screws. See diagram 2, section 5 'Cleaning the Riva'.
- Note: If the appliance is fitted with an alternative Gazco Riva front, please refer to the separate leaflet supplied with the front.

7. OXYGEN DEPLETION SENSOR

The appliance is fitted with an oxygen sensitive pilot system that will act to cut off the gas supply to the fire should the oxygen in the room fall below its normal level. If the fire is turned off by this device it usually indicates that there is a problem with the flue system, this should be inspected by a qualified engineer.

DO NOT ATTEMPT TO USE THE FIRE UNTIL AN ENGINEER SAYS IT IS SAFE TO DO SO.

THIS DEVICE IS NOT A SUBSTITUTE FOR AN INDEPENDENTLY MOUNTED CARBON MONOXIDE DETECTOR.

8. FLAME FAILURE DEVICE

This is a safety feature incorporated on this appliance which automatically switches off the gas supply if the pilot goes out and fails to heat the thermocouple.

USER INSTRUCTIONS

9. RUNNING IN

The surface coating on the logs used in your GAZCO fire will "burn off" during the first few hours of use producing a harmless and temporary odour. This will disappear after a short period of use. If the odour persists, ask your installer for advice.

10. SERVICING

The fire must be serviced every 12 months by a qualified Gas Engineer. In all correspondence always quote the Model Number and the Serial Number which may be found on the databadge.

IMPORTANT

If the appliance is installed using the Debris Deflector kit (Riva 67 only), it is essential that the chimney is inspected during every 12 monthly service as detailed in the *Servicing Instructions, 11*. Any build up of debris should be cleared before the Debris Deflector is replaced.

11. VENTILATION

Any purpose provided ventilation should be checked periodically to ensure that it is free from obstruction.

12. INSTALLATION DETAILS

To assist in any future correspondence, your installer should have completed the commissioning sheet at the front of this book, this records the essential installation details of the appliance. In all correspondence always quote the Model number and Serial number.

13. HOT SURFACES

Parts of this appliance become hot during normal use. It is therefore recommended that a suitable fire guard be used for protection of young children and the infirm. Indeed, all parts of the appliance should be treated as a 'working surface' except for the control access panel. If frames other than the Profil are being fitted, refer to their instructions.

INSTALLATION INSTRUCTIONS

TECHNICAL SPECIFICATION

COVERING THE FOLLOWING MODELS

MODEL	GAS CAT.	GAS TYPE	PRESSURE	AERATION		INJECTOR	GAS RATE m ³ /h	INPUT Kw		COUNTRY
								HIGH	LOW	
Riva 53 8596	I ₂ H	Natural Gas G20	20 mbar	8mm x 15mm		390	0.648	6.8 GROSS	3.0 GROSS	GB, IE
Riva 53 P8596	I ₃ P	LPG Propane G31	37 mbar	ø5.0mm	16 x 23	185	0.248	6.6 GROSS	3.0 GROSS	GB, IE
Riva 67 8590LUC	I ₂ H	Natural Gas G20	20 mbar	16mm x 12mm		400	0.648	6.8 GROSS	3.25 GROSS	GB, IE
Riva 67 P8590LUC	I ₃ P	LPG Propane G31	37 mbar	BLANK	16 x 23	185	0.252	6.7 GROSS	3.25 GROSS	GB, IE
Efficiency Class II Flue Outlet Size 127mm (5") Ø Gas Inlet Connection Size 8mm Ø										
Minimum flue specification				T260 / N2 / O / D / 1						
Maximum flue temperature				235°C						

PACKING CHECKLIST

RIVA 53

Qty	Description
1	Cassette and burner assembly
1	Decorative frame (if supplied)
1	Ceramic back panel*
1	Ceramic LH side panel*
1	Ceramic RH side panel*
1	Log set (7 logs)
1	Bag of granules
1	Fixing kit containing:
1	Instruction manual
4	Woodscrews
4	Rawlplugs
1	Self adhesive foam strip

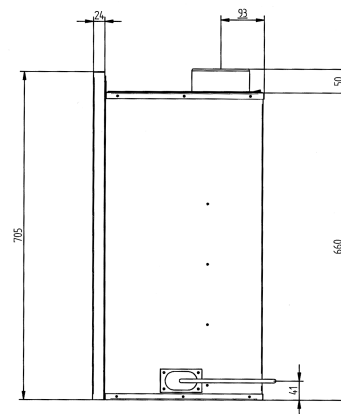
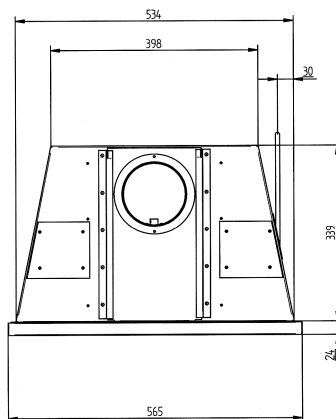

RIVA 67

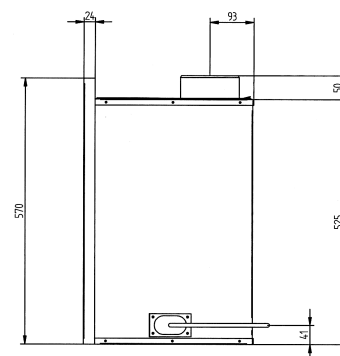
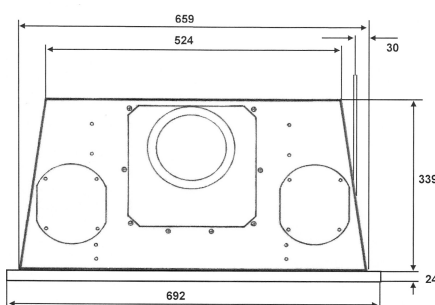

*Fitted in appliance

NOTE: All dimensions refer to the Riva when fitted with the Profil front.

Please refer to the separate Installation leaflet supplied with any alternative Gazco Riva front for applicable dimensions.

Optional Kits

- Debris Deflector (Riva 67 only) 8736
- Convection fan kit 8571
- Warm air ducting kit 8572

INSTALLATION INSTRUCTIONS

SITE REQUIREMENTS

1. FLUE AND CHIMNEY REQUIREMENTS

WHEN INSTALLING A FLUE SYSTEM PLEASE REFER TO THE MANUFACTURERS INSTRUCTIONS.

Due to the recent changes to European chimney standards, new flue's and chimney's are now described by their temperature, pressure and resistance to corrosion, condensation and fire. To assist in identifying the correct flue system, the minimum flue specification is shown in the *Technical Specification*. Existing chimneys are not covered by this system.

- 1.1 The chimney or flue system must comply with the rules in force, and must be 127mm (5") in diameter. Suitable systems are:

1.1.1 **Within an existing masonry fire place and chimney:**

- Flexible liner which must be continuous from the appliance spigot to the roof terminal.
- Gazco Debris Deflector kit (Riva 67 only)

UNDER NO CIRCUMSTANCES MUST THE DEBRIS DEFLECTOR KIT BE USED WITH ANY INSTALLATION OTHER THAN AN EXISTING MASONRY CHIMNEY WHICH HAS A MINIMUM DIAMETER OF 178mm (7"). THE CHIMNEY MUST BE SOUND AND CLEAN. IF PREVIOUSLY USED FOR SOLID FUEL, IT MUST BE SWEEPED PRIOR TO PROCEEDING WITH THE INSTALLATION.

NOTE: If the Debris Deflector kit is to be used, due care should be taken to prevent condensation forming in the chimney. Do not fit the Debris Deflector kit if the chimney is taller than 10 metres (external wall) or 12 metres (internal wall).

1.1.2 **Within a false chimney breast:**

- Single or twin wall rigid flue pipe.

- 1.2 The minimum effective height of the flue must be 3 metres (10ft).

- 1.3 The flue must be free from any obstruction.

Any damper plates should be removed or secured in the fully open position and no restrictor plates should be fitted.

- 1.4 The chimney should be swept immediately prior to the installation of the appliance. However, where it can be seen that the chimney is clean and unobstructed throughout its entire length, it need not be swept.

- 1.5 The Riva 53 is supplied with a flue fixing plate which allows the flue to be attached to the appliance within the aperture. See diagram 1.

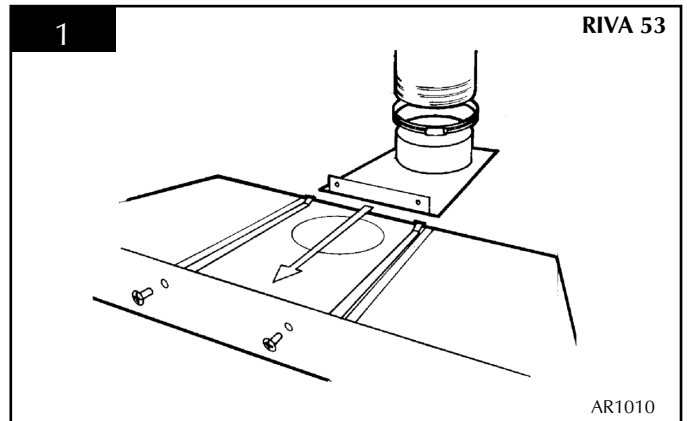

NOTE: If it is intended to install the Riva 53 into an existing masonry fireplace, a 5" (127mm) liner MUST be used.

- 1.6 The Riva 67 is designed so that the internal parts can be removed from the outer casing to make installation easier. This allows the liner or Debris Deflector to be connected and positioned within the chimney after the outer skin has been installed.

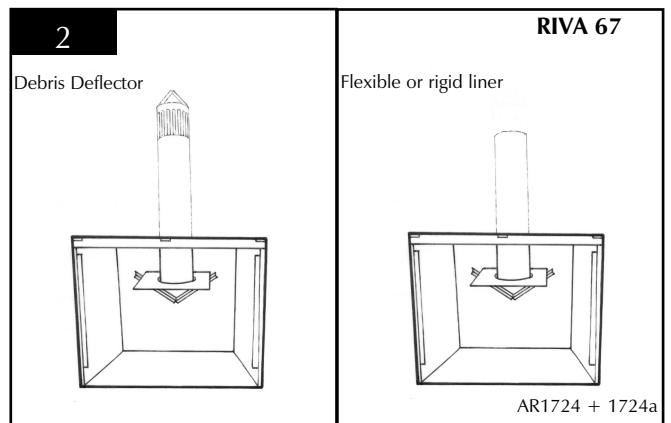

2. GAS SUPPLY

- Before installation, ensure that the local distribution conditions (identification of the type of gas and pressure) and the adjustment of the appliance are compatible.
- Ensure that the gas supply is capable of delivering the required amount of gas and is in accordance with the rules in force.
- Soft copper tubing can be used to install the appliance. Soft soldered joints can be used externally of the appliance but must be restricted to the area shown in diagram 3.

INSTALLATION INSTRUCTIONS

SITE REQUIREMENTS

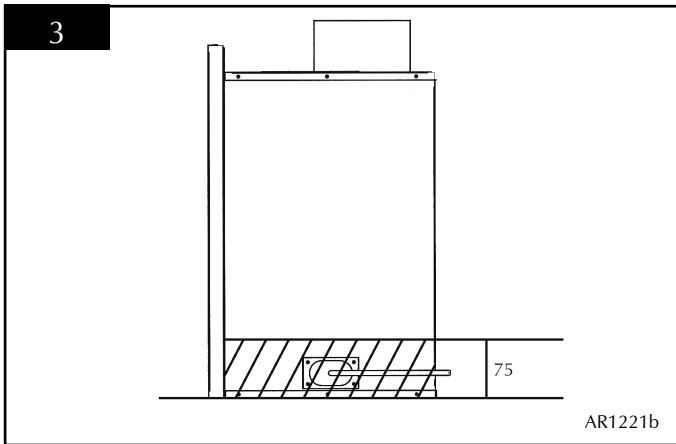

- 2.4 This appliance is supplied complete with a factory fitted isolation device incorporated into the inlet connection, no further isolation device is required.
- 2.5 All supply gas pipes must be purged of any debris that may have entered, prior to connection to the appliance.
- 2.6 The gas supply enters through the silicone panel located on the RH side of the outer box; this will need to be slit with a sharp knife prior to passing the supply pipe through.

3. VENTILATION

- 3.1 This appliance has a rated input below 7Kw and therefore does not normally require any additional ventilation. PLEASE REFER TO LOCAL AND NATIONAL CODES OF PRACTICE FOR VENTILATION REQUIREMENTS.

4. APPLIANCE LOCATION

- 4.1 **NOTE: If this appliance is fitted less than 150mm from the floor, then it will require a hearth to protect the floor. The hearth should have a minimum dimension of 12mm thick, projecting 300mm in front and 150mm either side of the appliance.**

The minimum opening dimensions are shown in diagram 3A.

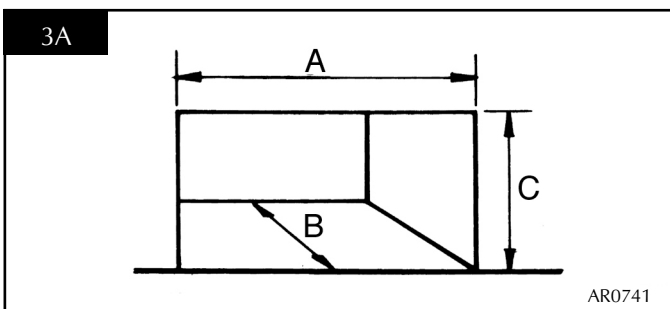

DIMENSION	RIVA 53	RIVA 67
A	540mm	670mm
B	350mm	350mm
C	665mm	530mm

- 4.2 This appliance must not be installed in a room that contains a bath or shower.
- 4.3 **NOTE: If using natural materials for the back panel of the fireplace, it is recommended that you construct it from three or more sections to prevent cracking. Resin-based materials may not be suitable. This appliance is an effective heat producer and attention must be paid to the construction and finish of the fireplace.**
- 4.4 This appliance is not suitable for installation onto a combustible wall; all combustible materials must be removed from the area shown in diagram 3B and 3C.

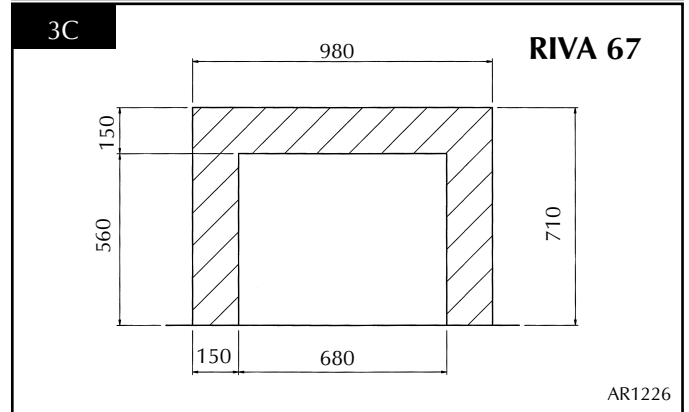
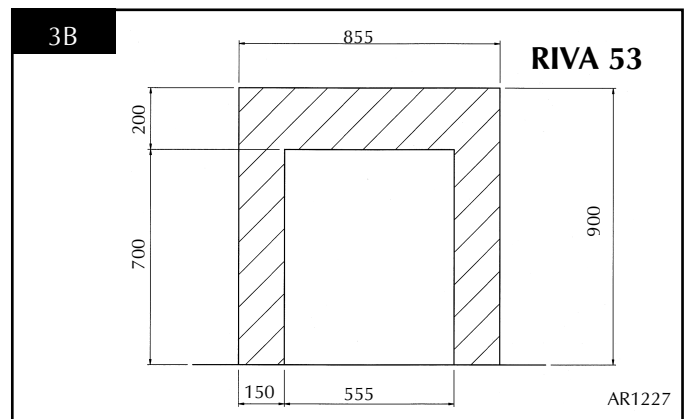

STUDWORK INSTALLATION

- 4.5 If a studwork installation is used (eg. wooden framework and plasterboard), combustible parts of the studwork must not be any closer than the minimum dimensions shown in the diagrams. NOTE: These dimensions must be maintained even if the combustible materials is protected by non-combustible linings
- 4.6 Do not pack the void around or above the appliance with insulation materials such as mineral wool.
- 4.7 The void into which the cassette is fitted must be ventilated to prevent a build up of heat. If the void is sealed then it will be necessary to fit vents at both low and high levels of approximately 50cm² each. These vents should take cold air from the room and return warm air back into the room.
- 4.8 A removable access hatch must be left in the side of the chimney breast for future servicing and inspection of the appliance.

INSTALLATION INSTRUCTIONS

SITE REQUIREMENTS

- 4.9 Build the studwork chimney breast to the desired size.
Ensure that the clearances to combustible materials is maintained.

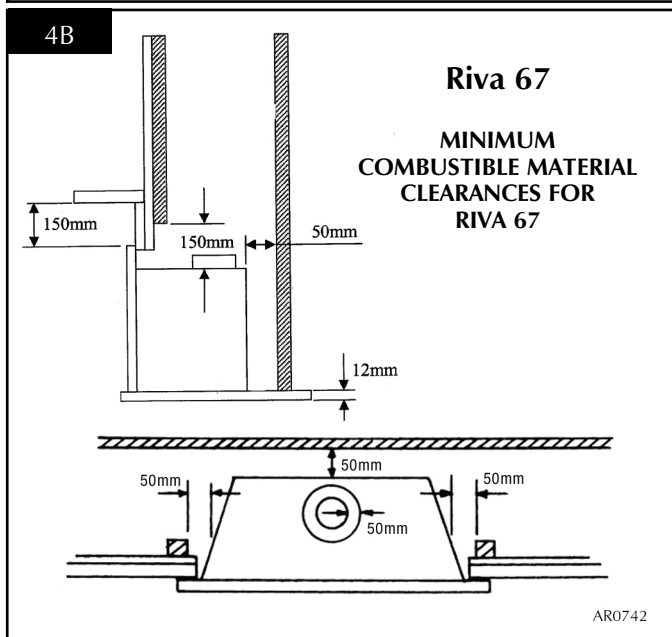
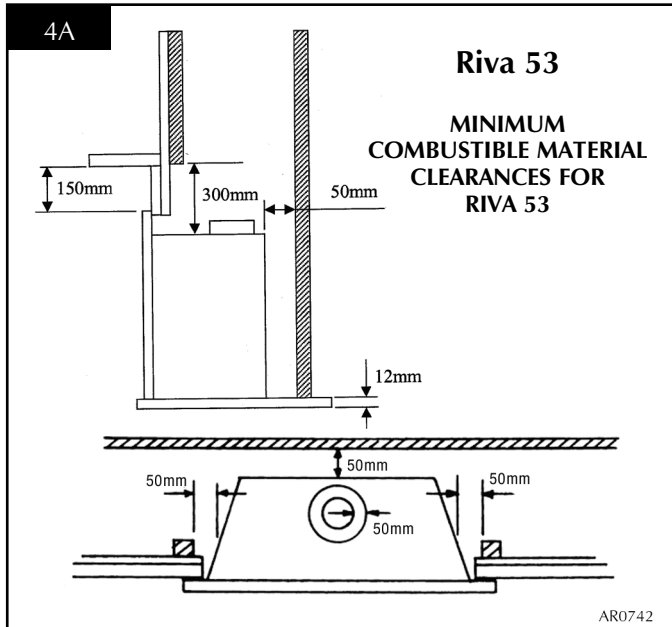

NOTE: THERE IS AN OPTIONAL CONVECTION FAN KIT AVAILABLE (GAZCO PART NUMBER 8571). THIS CAN BE FITTED EITHER DURING OR AFTER INSTALLATION BUT PROVISION FOR A POWER SUPPLY MUST BE MADE PRIOR TO INSTALLATION OF THE APPLIANCE. ALSO THERE IS A DUCT KIT (GAZCO PART NUMBER 8572) WHICH MUST BE INSTALLED AT THE SAME TIME AS THE APPLIANCE INSTALLATION.

It is recommended that a marble slip or similar material is used when fitting cassette fireplaces into a plastered surface, in order to allow for heat dissipation. Also allow adequate time for newly plastered areas to dry out. Rapid drying can create cracks. If in doubt, seek the advice of a professional plasterer.

Parts of this appliance become hot during normal use. It is therefore recommended that a suitable fire guard be used for protection of young children and the infirm.

INSTALLATION INSTRUCTIONS

INSTALLATION

IMPORTANT: ENSURE THAT THE APPLIANCE IS CORRECTLY ADJUSTED FOR THE GAS TYPE AND CATEGORY APPLICABLE IN THE COUNTRY OF USE. REFER TO DATA BADGE AND TECHNICAL SPECIFICATIONS ON PAGE 12.

FOR DETAILS OF CHANGING BETWEEN GAS TYPES REFER TO THE SERVICING SECTION.

1. CONTROL UPGRADE

- 1.1 This appliance is fitted with a control valve that can be easily upgraded to battery powered remote control. There are two versions of this control which can be obtained through your local Gazco stockist.
- 1.2 This upgrade can be fitted before or after installation. Full instructions are included with the kit.
- 1.3 **STANDARD REMOTE CONTROL** This remote control can control the gas appliance after the pilot has been lit. It can turn the main burner on and regulate it from low through to high and back again. It can turn the main burner off leaving the pilot burning. GAZCO PART NUMBER 8455.
- 1.4 **THERMOSTATIC AND TIMER REMOTE CONTROL** This remote control can control the gas appliance after the pilot has been lit. In 'MANUAL MODE' it can be used to turn the main burner on and manually regulate it from low through to high and back again. It can also be used to turn the main burner off leaving the pilot burning. In 'AUTO MODE' it will automatically regulate the room temperature. In 'TIMER MODE' it will turn the appliance on and off according to a pre-set programme and automatically regulate the room temperature during two on periods. GAZCO PART NUMBER 8456.

2. SAFETY PRECAUTIONS

- 2.1 This appliance must be installed in accordance with the rules in force, and used only in a sufficiently ventilated space. Please read these instructions fully before installation and use.
- 2.2 These instructions must be left intact with the user.
- 2.3 Do not attempt to burn rubbish on this appliance.
- 2.4 In your own interest, and those of safety, this appliance must be installed by competent persons in accordance with local and national codes of practice. Failure to install the appliance correctly could lead to prosecution.
- 2.5 Keep all plastic bags away from young children.
- 2.6 Do not place any object on or near to the appliance.
- 2.7 The appliance is fitted with an oxygen sensitive pilot that will act to cut off the gas supply to the appliance in the event of incorrect operation of the flue. If the system acts to shut off the gas supply, this indicates that there is insufficient flue pull. Continued operation of this safety device means that there may be a serious problem with the flue system, and this should be inspected by a qualified gas engineer. **Do not use the appliance until an engineer says it is safe to do so.**

The oxygen sensitive pilot must not be tampered with. Use only genuine Gazco replacement parts when servicing the appliance - refer to Servicing section.

3. INSTALLATION OF THE APPLIANCE GENERAL

- 3.1 Remove the appliance from the carton and discard all unnecessary packaging. Ensure no components are thrown away when unpacking.
- 3.2 If you have purchased a Profil decorative front, this will be located inside the cardboard fitment situated in front of the Riva cassette. Remove from packaging and place to one side until required.
- 3.3 Remove the glass door by unscrewing the six retaining screws. See diagram 1, arrow A. Carefully remove the box containing the logs from the firebox. Place to one side as these are fragile. The ceramic panels are factory fitted, take care not to damage these components.

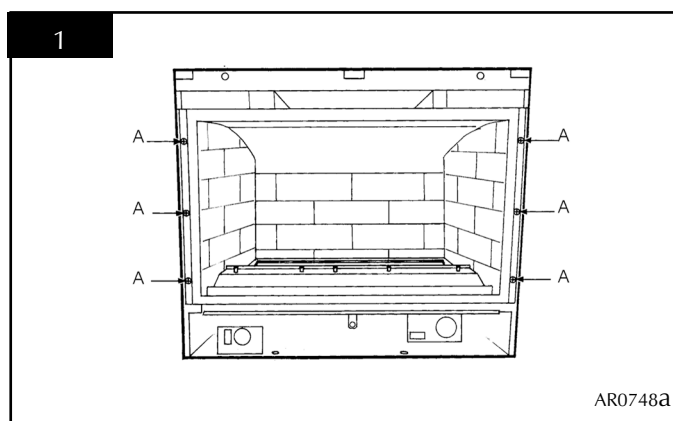

- 3.4 The gas supply enters through the silicone panel located on the right-hand side of the outer box; this will need to be slit with a sharp knife prior to passing the supply pipe through. See diagram 2.

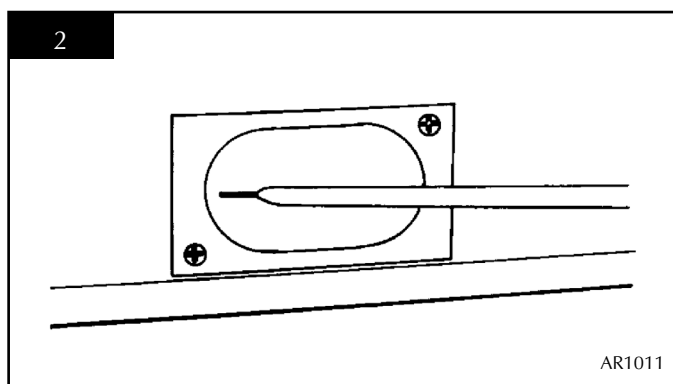

- 3.5 **When installing the appliance into a combustible enclosure, ensure all the clearances are observed. Refer to Site Requirements section 4.1.**

INSTALLATION INSTRUCTIONS

INSTALLATION

4. INSTALLATION OF RIVA 53

- 4.1 The flue spigot on this appliance is suitable for connection to a 5" (127mm) flexible flue liner or rigid flue pipe. If a liner is to be used, detach the sliding flue connector from the top of the appliance by removing the 2 screws located on the front flange. See diagram 3.
- 4.2 Locate the flue liner in position and place the flue securing clip over the liner, push the end of the liner over the outside of the spigot and secure by tightening the securing clip. See diagram 3.

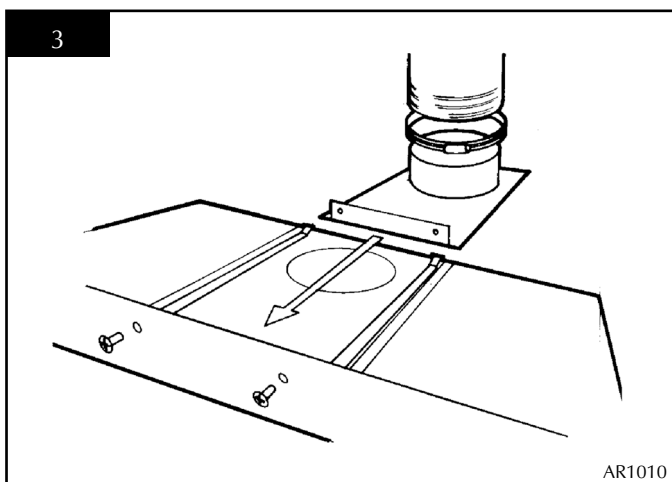

- 4.3 Place the liner in its final position ensuring that the sliding flue plate rests at the correct height in the opening, and that the front flange of the plate rests against the outside face at the top of the opening.
- 4.4 Check the pull of the flue system by applying a lighted smoke pellet to the flue system opening. If there is a definite flow into the chimney, proceed with the installation, if not; warm the chimney for a few minutes.
IF THERE IS STILL NO DEFINITE FLOW, THE FLUE MAY REQUIRE ATTENTION - SEEK EXPERT ADVICE.
- 4.5 Remove the backing paper from the silicone foam strip supplied in the fixing kit and fix to the back of the outer flanges of the appliance, ensure that it is located below the frame location lugs on the top flange.
- 4.6 Feed gas supply through right-hand side of the appliance. See Diagram 2. Locate the edges of the sliding flue plate in the runners located on top of the outer box and slide the appliance backwards into the opening ensuring that the sliding plate fully locates in the runners, secure in place with the 2 previously removed screws. See diagram 3.
- 4.7 Remove the compression elbow from the appliance and connect it to the gas supply pipe. As the appliance is located into the enclosure pass the elbow and supply pipe through the silicone panel on the right-hand side. **PURGE THE SUPPLY PIPE.** This is essential to expel any debris that may block the gas controls. Connect the elbow to the appliance inlet pipe. See diagram 4.

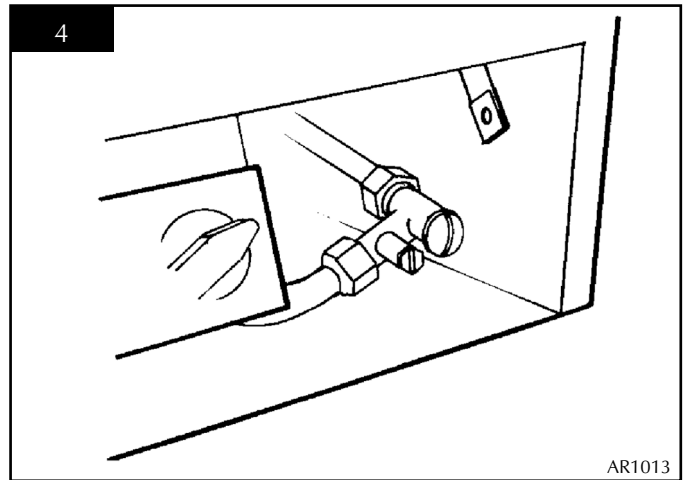

- 4.8 Secure the appliance through the four fixing holes using the screws provided. See diagram 5, arrow B.

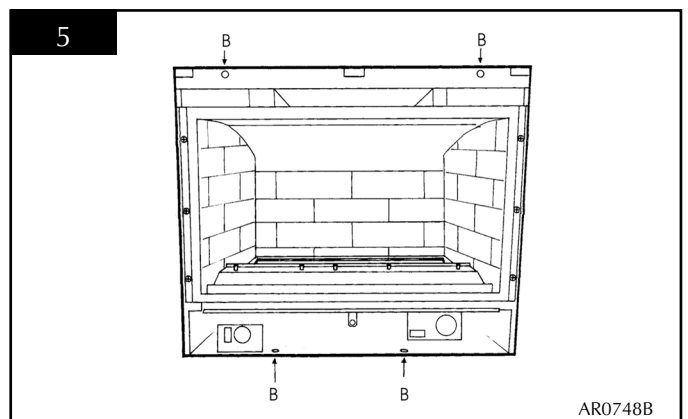

5. INSTALLATION OF RIVA 67

- 5.1 **When installing the appliance into a combustible enclosure, ensure all the clearances are observed. Refer to Site Requirements section 4.1.**
- 5.2 The flue spigot on this appliance is suitable for connection to a 5" (127mm) flexible flue liner or rigid flue pipe. Alternatively, it can be fitted to the optional Gazco Debris Deflector. This removes the need for a flue liner.
- Note: Ensure that the flue is not subject to condensation, see 1.1**
- 5.3 If a liner or the Debris Deflector is being fitted proceed as follows:
- 5.4 Remove the ceramic panels and log support as detailed in Section 2 of the *Servicing Instructions*. Remove the burner module and place safely to one side.
- 5.5 Remove the four screws securing the inner to the outer box and undo the two screws behind the rear ceramic panel. Diagram 6.

INSTALLATION INSTRUCTIONS

INSTALLATION

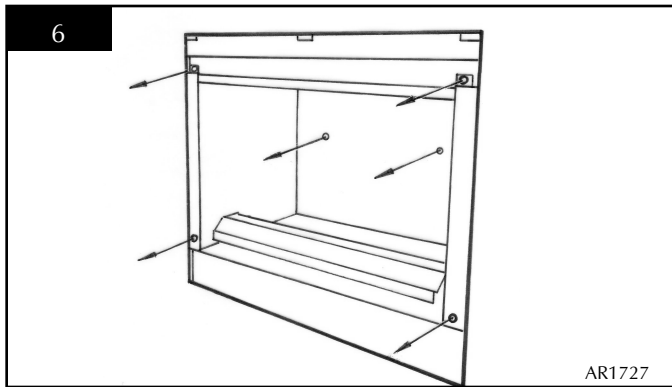

5.6 Slide the inner box away from the outer box by pulling it forward. Diagram 7

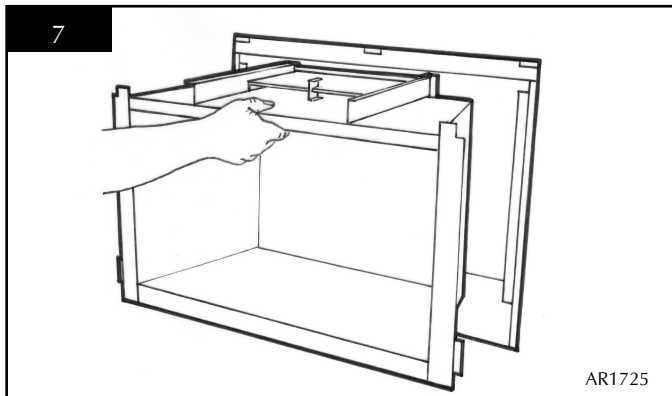

5.7 Remove the backing paper from the silicone foam strip supplied in the fixing kit and fix to the back of the outer flanges of the appliance, ensure that it is located below the frame location lugs on the top flange.

5.8 Feed the gas supply through the right-hand side of the outer box, see Diagram 2, and slide the outer box backwards until its outer flange sits neatly onto the wall. Secure the outer box through the four fixing holes using the screws provided. Diagram 8.

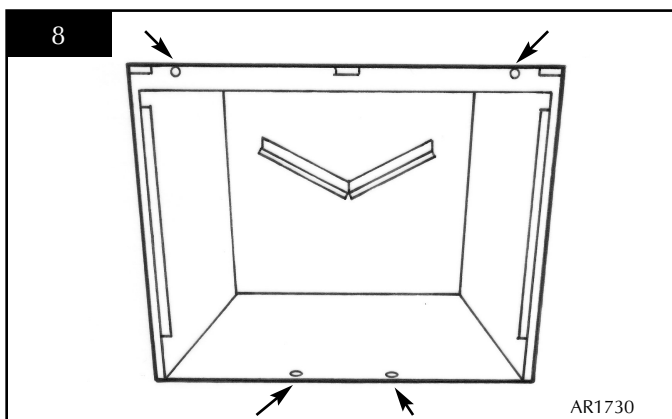

5.9 Flexible Liner

5.9.1 Remove the eight screws on the spigot plate, Diagram 9.

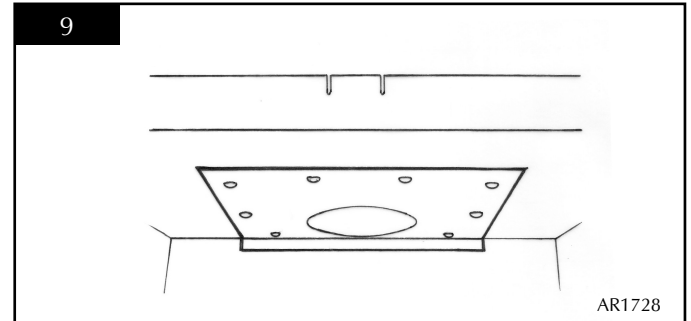

5.9.2 Pull the liner through the hole in the top of the outer box and attach it to the flue spigot plate using the clip provided. Tighten the clip securely. Diagram 10.

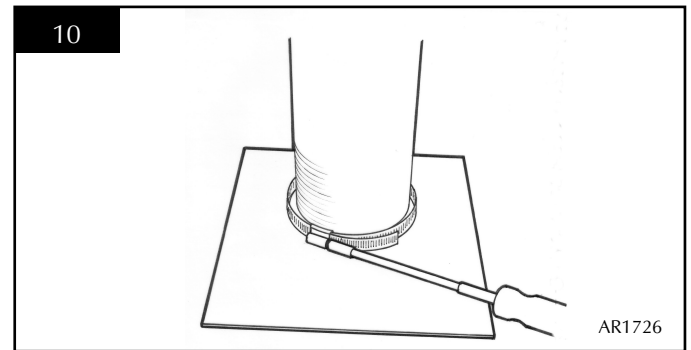

5.9.3 Secure the flue spigot plate to the inside top surface using the eight screws provided. Diagram 9.

5.10 Debris Deflector Assembly

Components:

- a) Flue pipe
- b) End terminal
- c) Clip
- d) Warning label

5.10.1 The flue pipe is supplied with tape around each end of the flue to protect your hands from the sharp edges. You must remove the tape before assembling the debris deflector.

5.10.2 Place clip over one end of the flue pipe and insert the End Terminal inside of the flue pipe. Do not insert the End Terminal past the point shown in Diagram 11.

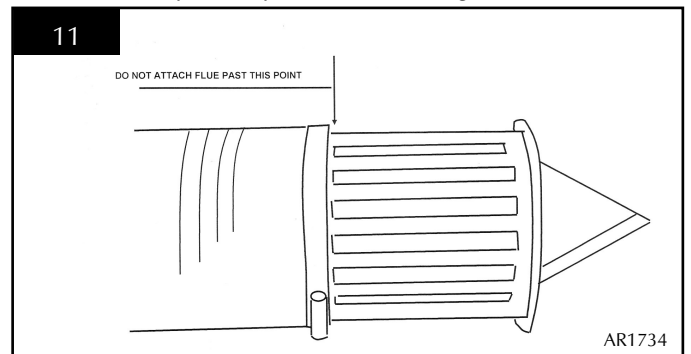

INSTALLATION INSTRUCTIONS

INSTALLATION

5.10.3 Tighten the clip until the End Terminal is secured firmly in place.

5.11 Attach the Debris Deflector to the flue spigot plate using the clip provided. Tighten the clip securely. Diagram 12.

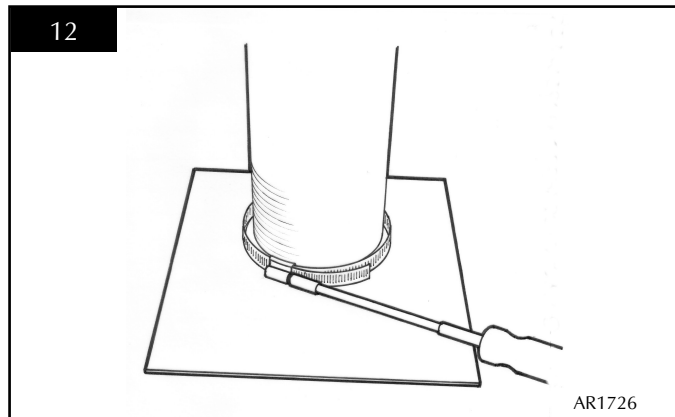

5.12 Push the Debris Deflector up into the chimney and secure the flue spigot plate to the inside top surface using the eight screws provided. Diagram 13.

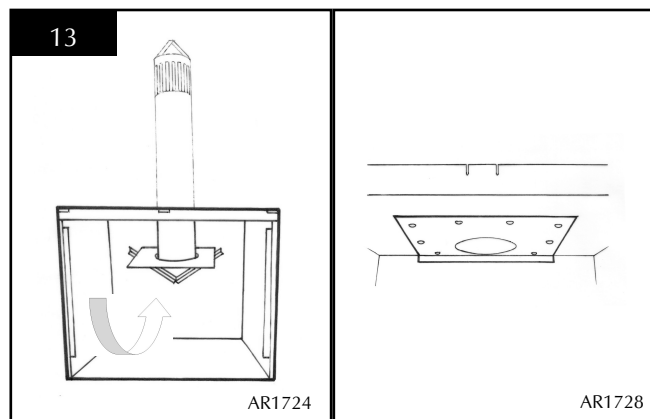

5.13 Attach the label supplied with the Debris Deflector to the base of the appliance on the front right-hand side as shown.

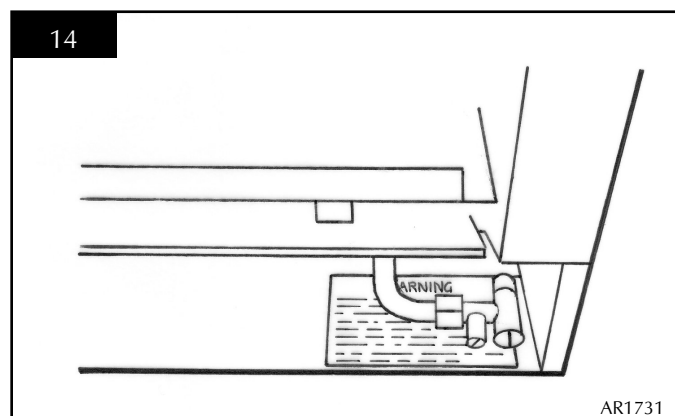

5.14 Locate the top of the inner box into the runners at the top of the outer box. Diagram 15.

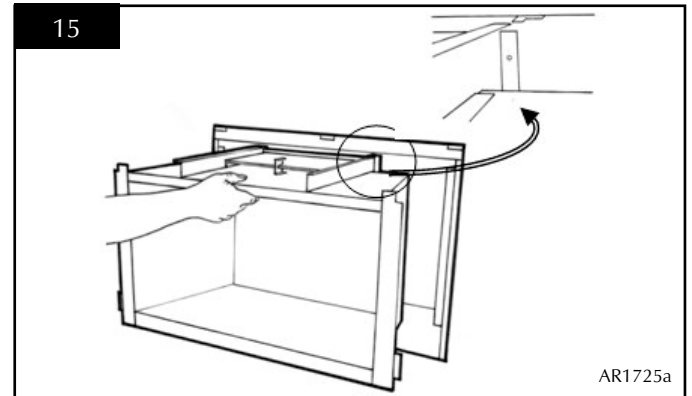

5.15 Gently slide the inner box into the outer box until the two flanges meet. Secure with the screws on the flange and the two screws on the inside rear surface as shown.

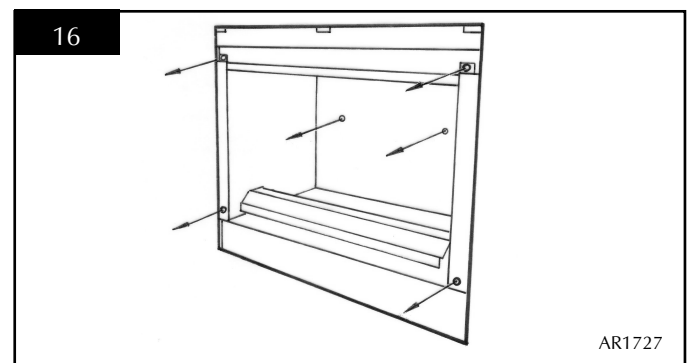

5.16 Replace the burner module and secure in position. Replace the log support and ceramic panels as detailed in Section 2 of the *Servicing Instructions*.

5.17 PURGE THE SUPPLY PIPE. This is essential to expel any debris that may block the gas controls. Connect the elbow to the appliance inlet pipe. See diagram 17.

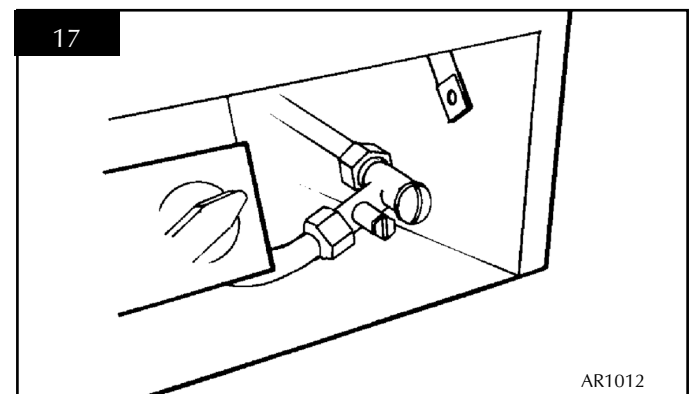

INSTALLATION INSTRUCTIONS

INSTALLATION

6. GAS SOUNDNESS PRESSURE CHECK

- 6.1 Connect a suitable pressure gauge to the test point located on the inlet fitting and turn the gas supply on. Light the appliance and check all gas joints for possible leaks. Turn the appliance to maximum and check that the supply pressure is as stated on the databadge. Turn the gas off and replace the test point screw, turn the gas on and check the test point for leaks.

7. ARRANGEMENT OF FUEL BED COMPONENTS

ADVICE ON HANDLING AND DISPOSAL OF FIRE CERAMICS

The fuel effect and side panels in this appliance are made from Refractory Ceramic Fibre (RCF), a material which is commonly used for this application.

Protective clothing is not required when handling these articles, but we recommend you follow normal hygiene rules of not smoking, eating or drinking in the work area and always wash your hands before eating or drinking.

To ensure that the release of RCF fibres are kept to a minimum, during installation and servicing a HEPA filtered vacuum is recommended to remove any dust accumulated in and around the appliance before and after working on it. When servicing the appliance it is recommended that the replaced items are not broken up, but are sealed within heavy duty polythene bags and labelled as RCF waste.

RCF waste is classed as stable, non-reactive hazardous waste and may be disposed of at a licensed landfill site.

Excessive exposure to these materials may cause temporary irritation to eyes, skin and respiratory tract; wash hands thoroughly after handling the material.

THE BAG OF GRANULES CONTAINED IN THE LOG SET IS TO SIMULATE AN ASH EFFECT. THIS IS NOT TO BE PLACED ON THE BURNER.

- 7.1 Place some of the granules around the rear and sides of the burner tray. **ENSURE NO GRANULES FALL ON THE BURNER.** See diagram 18.

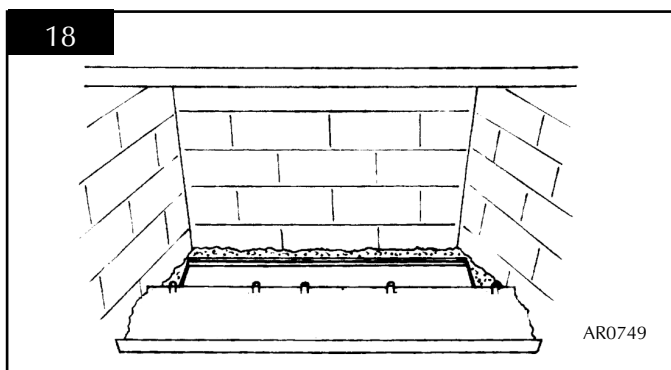

- 7.2 Place log 1 (large black log) on the burner. Ensure the rear of the log touches the rear of the burner. See diagram 19.

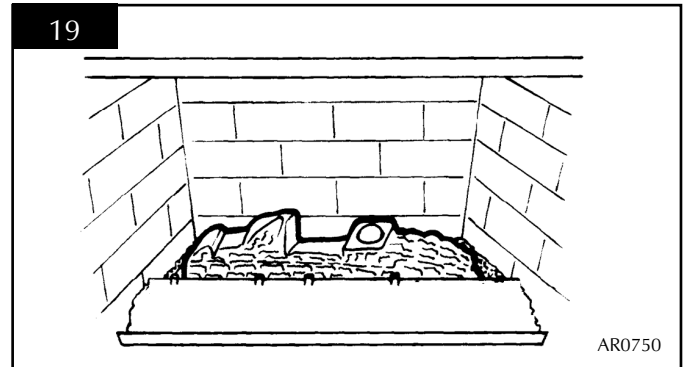

CENTRALISE THE LOG BETWEEN THE BURNER PORTS AT EITHER END.

ALL THE REMAINING LOGS EXCEPT FOR THE SMALLEST ONE HAVE LOCATION HOLES ON THE UNDERSIDE, THESE LOCATE ON THE STUDS AT THE FRONT OF THE FIRE.

- 7.3 Place log 2 on the centre and locate the rear of the log on the large flat area of log 1. See diagram 20.

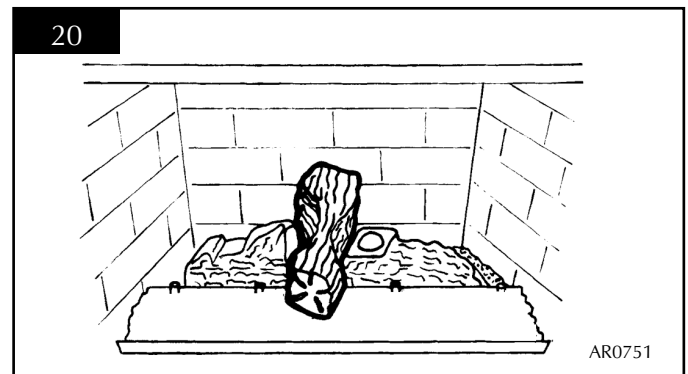

- 7.4 Place log 3 on the far left-hand stud. The recess on the underside of the log should locate on the top of log 1 on the far left-hand side. See diagram 21.

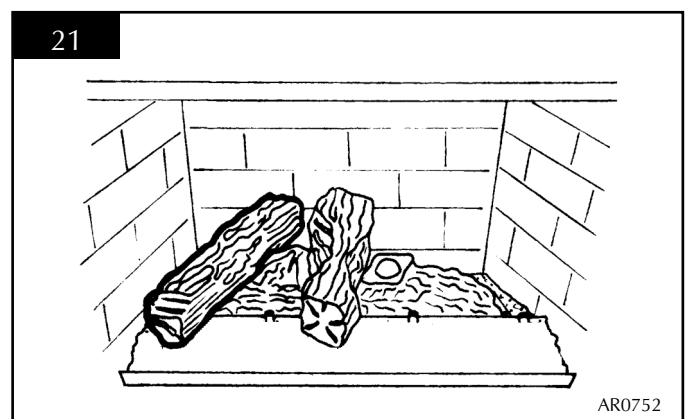

INSTALLATION INSTRUCTIONS

INSTALLATION

- 7.5 Place log 4 on the right-hand side of the centre log. There is a large recess on the underside of the log, which is located on log 1. See diagram 22.

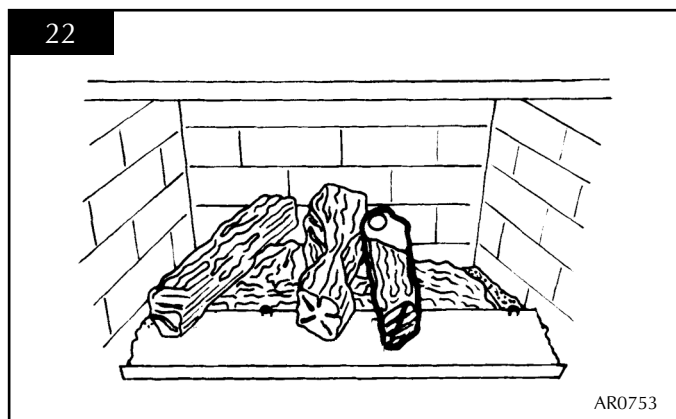

- 7.6 Place log 5 on top of log 4 and ensure the two large locations engage. Locate the front of the log on to the far right-hand stud. See diagram 23.

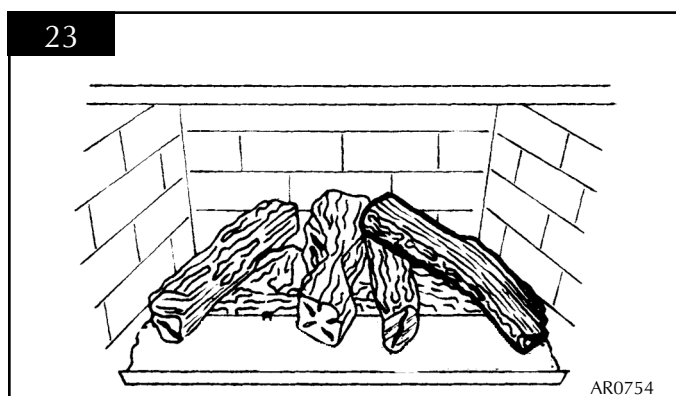

- 7.7 Place log 6 on the remaining stud and lean the log on to log 1 between logs 2 and 3. There is a notch to locate the log. See diagram 24.

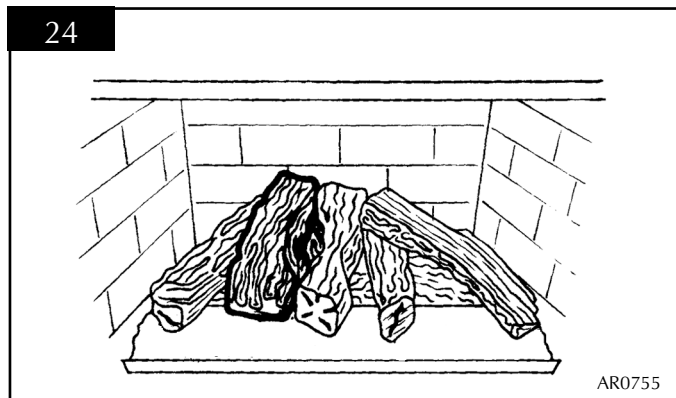

- 7.8 Place log 7 at the front of the fire between logs 4 and 5. **DO NOT PLACE THIS LOG ON THE BURNER. IT IS ONLY TO FILL THE GAP BETWEEN LOGS 4 AND 5.** The charred effect should face the rear of the fire.

Place the remaining granules between the logs so that they cover the front metal ledge. See diagram 25.

ENSURE NO GRANULES FALL ON THE BURNER.

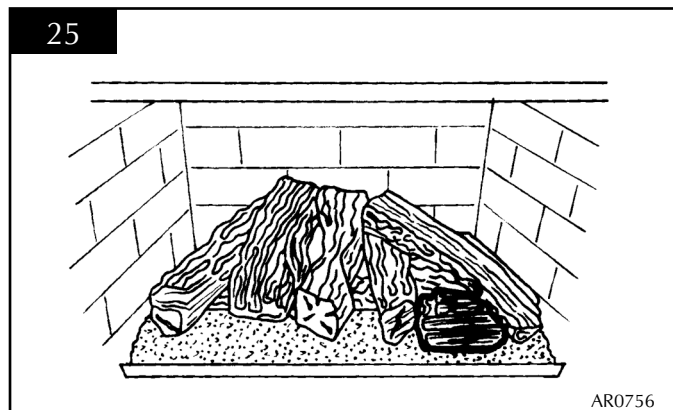

RIVA 53

- 7.9 Place log A on to the burner. Ensure the rear of the log touches the rear burner. See diagram 26.

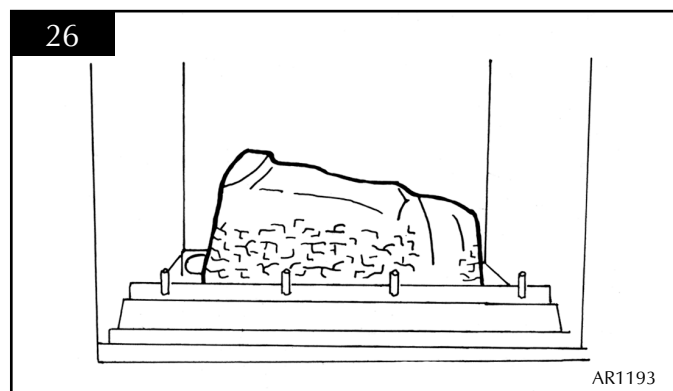

CENTRALISE THE LOG BETWEEN THE BURNER PORTS AT EITHER END.

Four of the remaining logs have location holes on the underside. These locate on the studs at the front of the fire.

- 7.10 Place log D on the third stud from the left and resting at the rear on log A. See diagram 27.

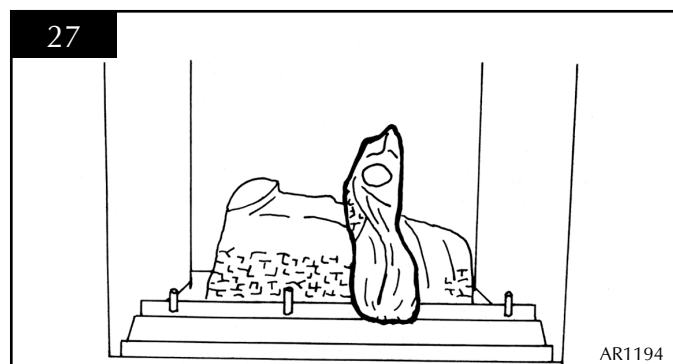

INSTALLATION INSTRUCTIONS

INSTALLATION

- 7.11 Place log C on the second stud resting at the rear on log A. See diagram 28.

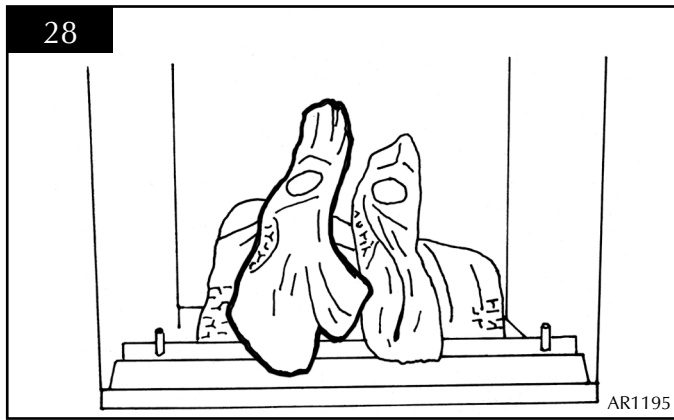

- 7.12 Place log B on the first stud. The recess on the underside of the log should locate on the top of log C. See diagram 29.

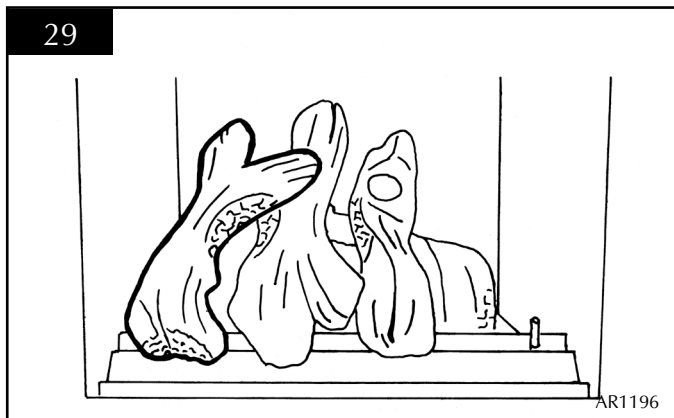

- 7.13 Place log E on the last stud. The recess on the underside of the log should locate on to the top of log D. See diagram 30.

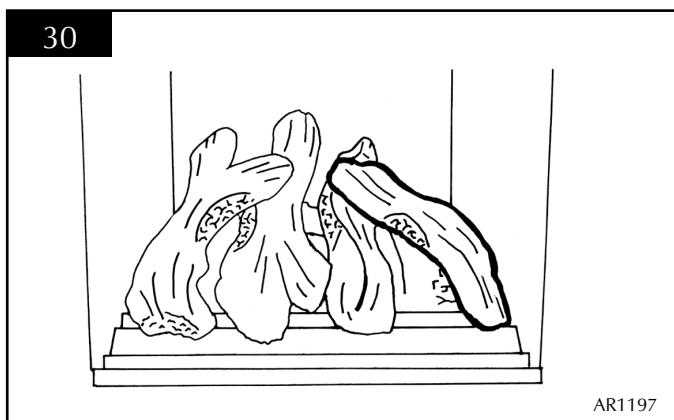

- 7.14 Place log F on the rear tray and leaning forward to locate in the recess in log E. See diagram 31.

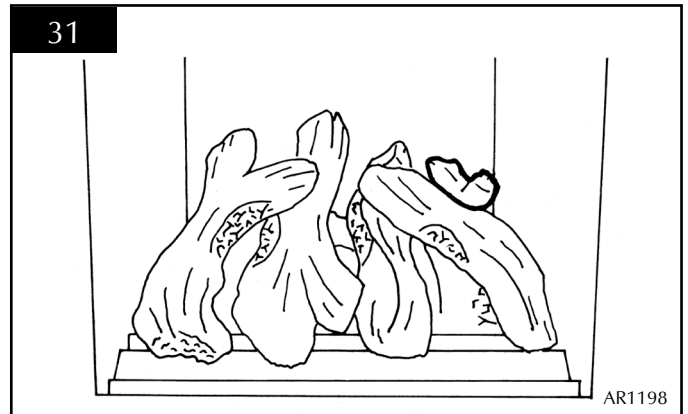

- 7.15 Place log G at the front of the fire between logs D and E. DO NOT PLACE THIS LOG ON THE BURNER. IT IS ONLY TO FILL THE GAP BETWEEN LOGS D AND E. The charred effect should face the rear of the fire. See diagram 32.

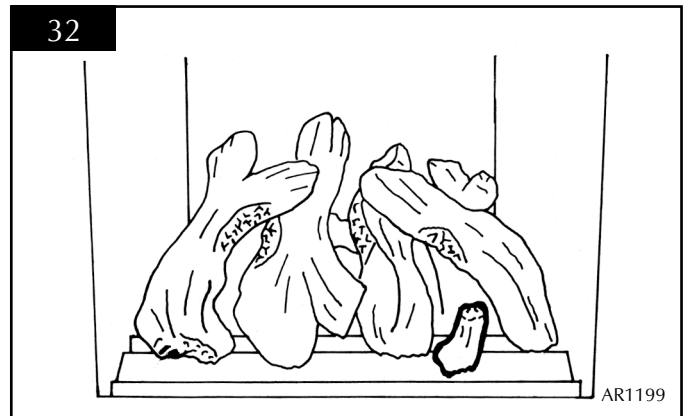

- 7.16 With the granules fill the front compartment around the logs evenly. ENSURE NO GRANULES FALL ON THE BURNER. See diagram 33.

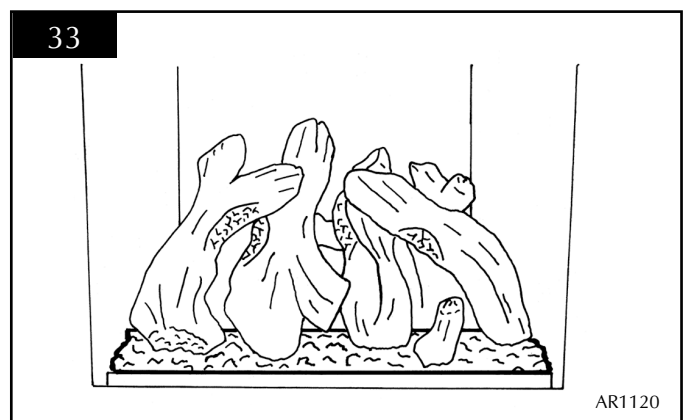

- 7.17 **NOTE: ENSURE THAT THE LOGS ARE POSITIONED AS ABOVE. ONLY USE THE CORRECT AMOUNT OF LOGS AS SPECIFIED IN THE DIAGRAMS.**

INSTALLATION INSTRUCTIONS

INSTALLATION

- 7.18 Ensure that the fibreglass seal on the back of the glass frame is intact then hook the location tabs over the hooks on the top of the firebox. Replace the six screws working from the top down. Tighten the screws evenly. **DO NOT OVER TIGHTEN.**

NEVER OPERATE THE APPLIANCE WHEN THE GLASS PANEL IS REMOVED OR BROKEN.

- 7.19 Replace the Profil frame by hooking the top over the location lugs on top of the flanges, replace the two fixing screws. See diagram 5, section 7 'Cleaning the Riva'.

Note: If the appliance is fitted with an alternative Gazco Riva front, please refer to the separate leaflet supplied with the front.

8. FITTING THE DOOR

- 8.1 Ensure that the fibreglass seal on the back of the glass frame is intact then hook the location tabs over the hooks on the top of the firebox. Replace the six screws working from the top down. Tighten the screws evenly. **DO NOT OVER TIGHTEN.** See diagram 2, Section 5 'Cleaning the Riva'.

NEVER OPERATE THE APPLIANCE WHEN THE GLASS PANEL IS REMOVED OR BROKEN.

- 8.2 Replace the decorative frame by hooking the top over the location lugs on top of the flanges, replace the two fixing screws, see diagram 1, Section 5 'Cleaning the Riva'.

NOTE: If the appliance is fitted with an alternative Gazco Riva front, please refer to the separate leaflet supplied with the front.

NOTE: ENSURE THAT THE LOGS ARE POSITIONED AS ABOVE. ONLY USE THE CORRECT AMOUNT OF LOGS AS SPECIFIED IN THE DIAGRAMS.

9. LIGHTING THE RIVA

- 9.1 Locate the control valve on the appliance. There are two control knobs on the valve, the right-hand knob controls the pilot ignition and the left-hand knob controls the main burner. See diagram 32.

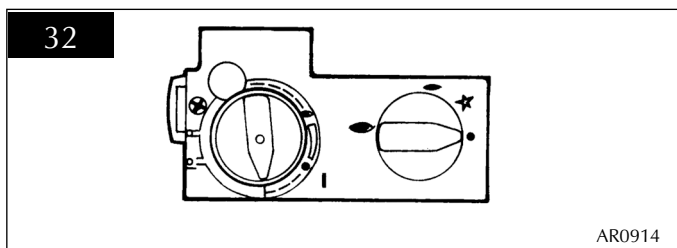

- 9.2 If your appliance has already been upgraded to battery remote control, please refer to the instructions provided with the upgrade to operate the remote control. The following instructions will work for either situation.
- 9.3 Ensure that the left-hand control knob is pointing to off (●).
- 9.4 Ensure that the right-hand control knob is pointing to off ●.

- 9.5 Press in the right-hand control knob and rotate it anti-clockwise until a click is heard (keep pressing in) and the knob is pointing to pilot (●). The pilot should now light. If the pilot has not lit, repeat the procedure until it does.
- 9.6 Keep the control knob pressed for 10 seconds and then release it, the pilot should stay alight. If the pilot goes out, repeat the procedures until it does.
- 9.7 If the pilot will not light after repeated attempts, contact the retailer or installer from whom the appliance was purchased.
- 9.8 Turn the right-hand control to point to main burner (●). The appliance can now be controlled using the left-hand control knob.
- 9.9 Turn the left-hand control knob to point to low fire (●), the main burner will light on low. The burner can now be controlled between low and high settings. Turn the control knob anticlockwise to increase the flame height and clockwise to decrease the flame height.

THE YELLOW FLAMES WILL APPEAR WHEN THE FIRE HAS GAINED SUFFICIENT HEAT - TYPICALLY 10 TO 20 MINUTES.

INSTALLATION INSTRUCTIONS

COMMISSIONING

1. COMMISSIONING THE RIVA

- 1.1 Check flame picture.
- 1.2 Check gas pressure.
- 1.3 Close all doors and windows in the room, ignite the appliance and operate on maximum for 5 minutes. Position a lighted smoke match just inside the draught diverter opening and check that all the smoke is drawn in all along the opening. If there is any doubt, run the appliance for a further 10 minutes, and repeat the test. See diagram 1.

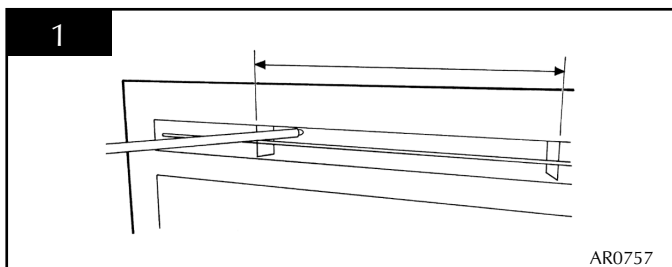

- 1.4 If there are any extractor fans in the room or adjacent rooms, the test must be repeated with the fans running on maximum.

IF SPILLAGE PERSISTS, DISCONNECT THE APPLIANCE AND SEEK EXPERT ADVICE.

For future reference record the installation details on the commissioning sheet on page 3.

SERVICING INSTRUCTIONS

SERVICING/FAULT FINDING CHARTS

1. SERVICING REQUIREMENTS

This appliance must be serviced at least once a year by a competent person.

All tests must be serviced by best practice as described by the current CORGI recommendations.

- 1.1 Before any test are undertaken on the appliance, conduct a gas soundness test for the property to ensure that there are no gas leaks prior to starting work.
- 1.2 Before any tests are undertaken on the appliance it is also recommended to fully check the operation of the appliance.
- 1.3 **RIVA 67 Only**
Check if the appliance has been fitted with a Debris Deflector as indicated on the Appliance Commissioning Checklist on page 3 and a label attached to the base of the unit. See diagram 1.

If the appliance has been fitted with this device, then it is essential to remove the appliance to check the debris collection space immediately above the appliance inside the chimney. See *Installation of Riva 67, Section 5, Installation Instructions*.

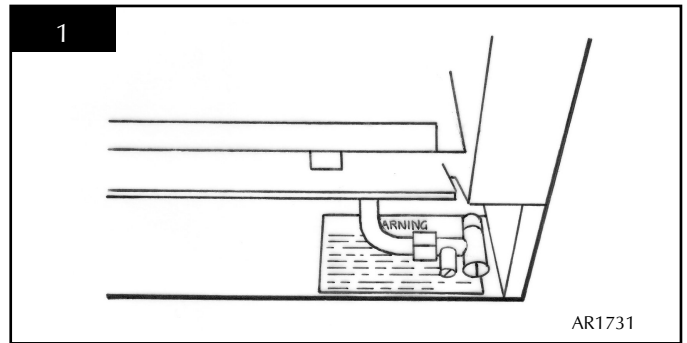

- 1.4 Correct any faults found during the initial tests. Re-commission the appliance conducting the usual safety checks.
- 1.5 Advise the customer of any remedial action taken.
- 1.6 Check the seal on the inner lip of the spigot plate is intact. Replace if necessary, see *Replacing Parts, 11*.

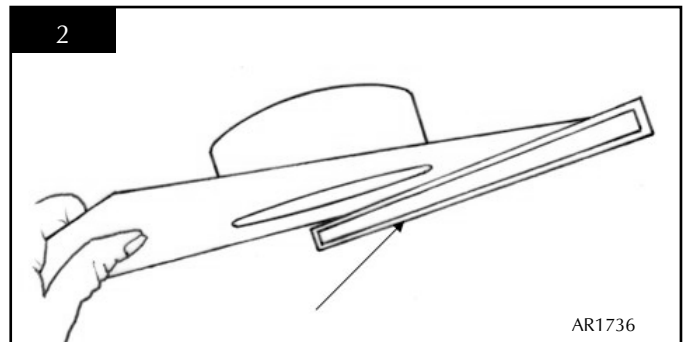

IGNITION FUNCTIONAL CHECK 1

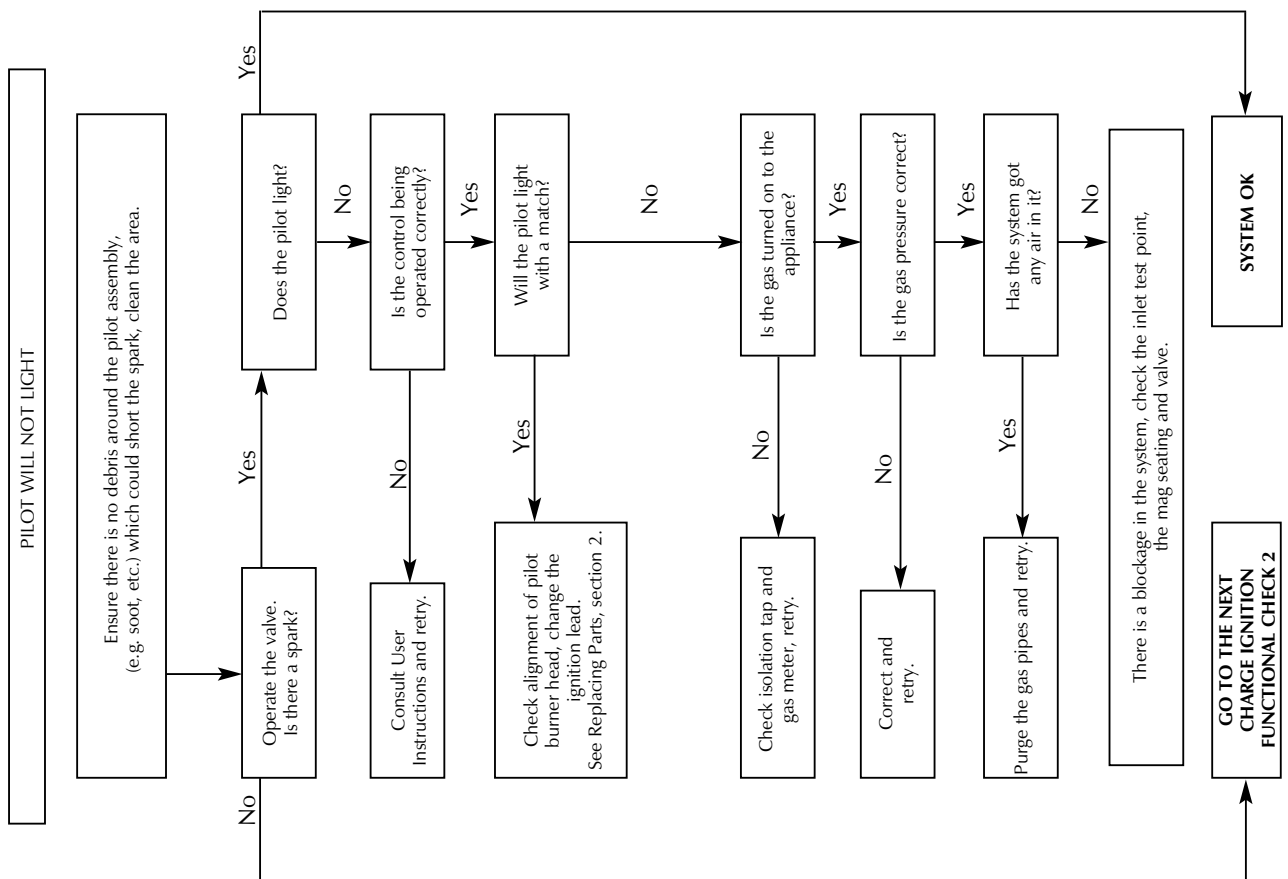

SERVICING INSTRUCTIONS

FAULT FINDING CHARTS

FLAME FAILURE FUNCTIONAL CHECK 3

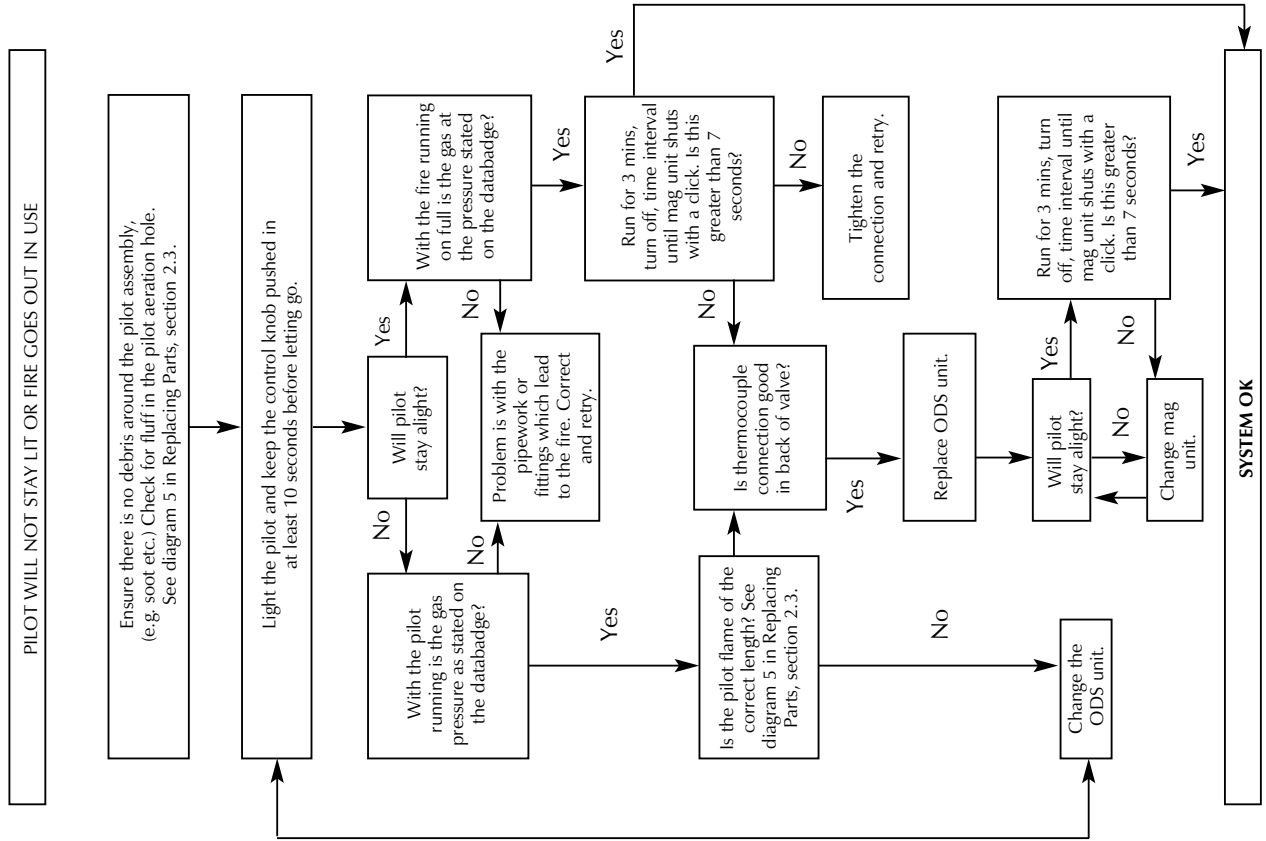

IGNITION FUNCTIONAL CHECK 2

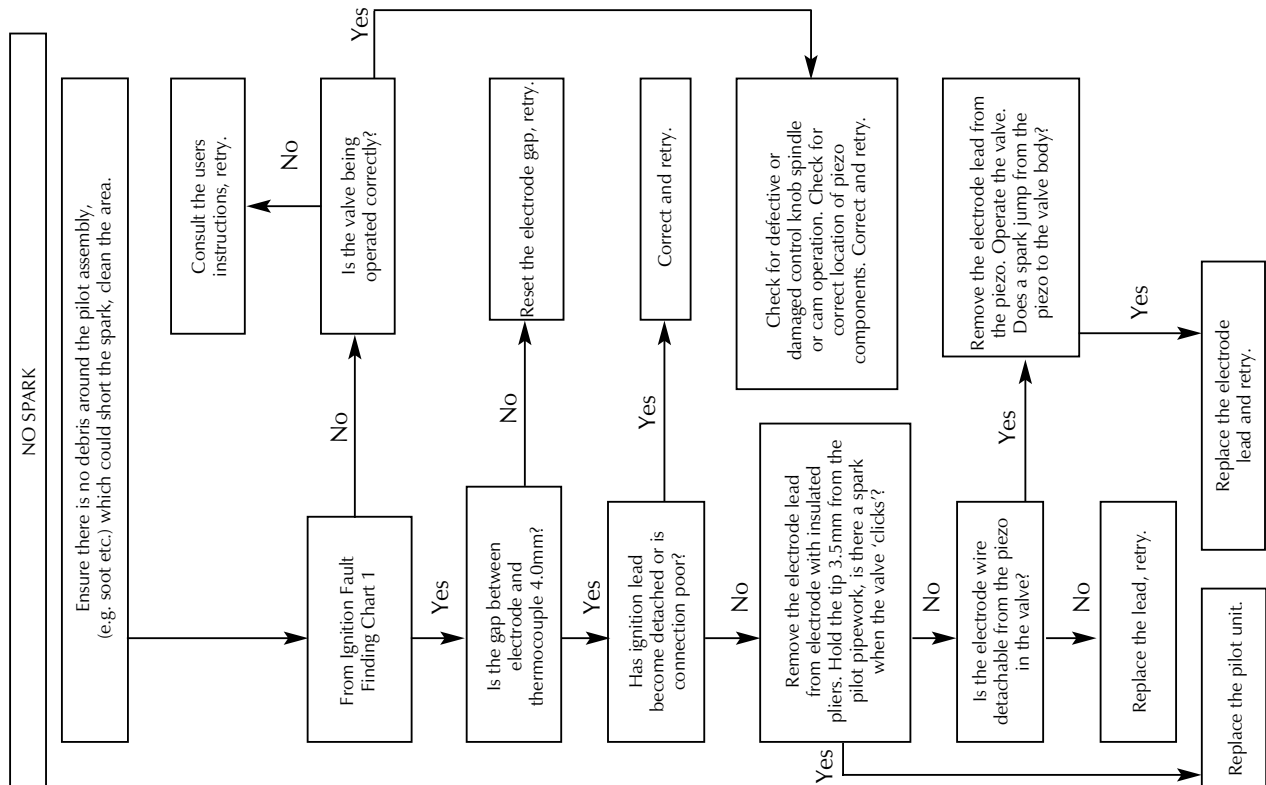

SERVICING INSTRUCTIONS

REPLACING PARTS

1. GENERAL

- 1.1 All principal components can be replaced without removing the appliance from its installation, although it is essential that the gas supply to the appliance is turned off at the isolation device before proceeding further.
- 1.2 It will be necessary to remove the complete burner module before any of the components can be serviced.
- 1.3 If the appliance is fitted with a debris deflector (**Servicing 1.3**), it will be necessary to remove the inner appliance to inspect the debris collection space.

2. REMOVE THE BURNER MODULE

- 2.1 To remove the module the procedure is as follows:
 - a) Remove the decorative front, see diagram 1.
(If the appliance is fitted with any front other than the Profil, please refer to the *Instructions* supplied with the front for removal.)

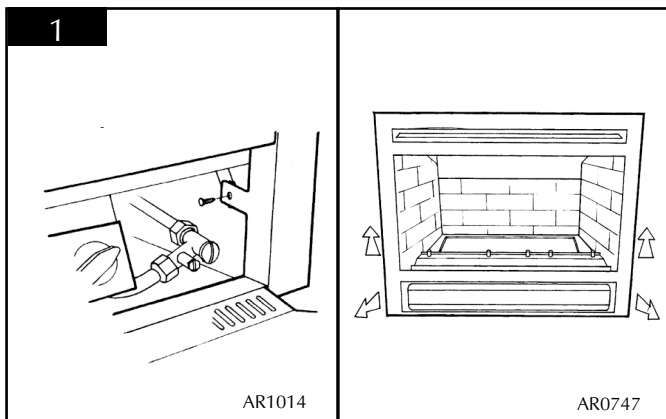

- b) Remove the glass frame. See diagram 2, arrow A.

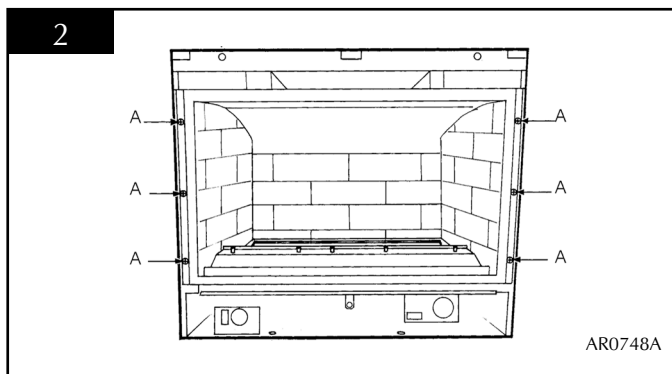

- c) Remove the ceramic logs.
- d) Remove the granules.
- e) Carefully slide the side panels forward and store safely. (These are very fragile). See diagram 3.

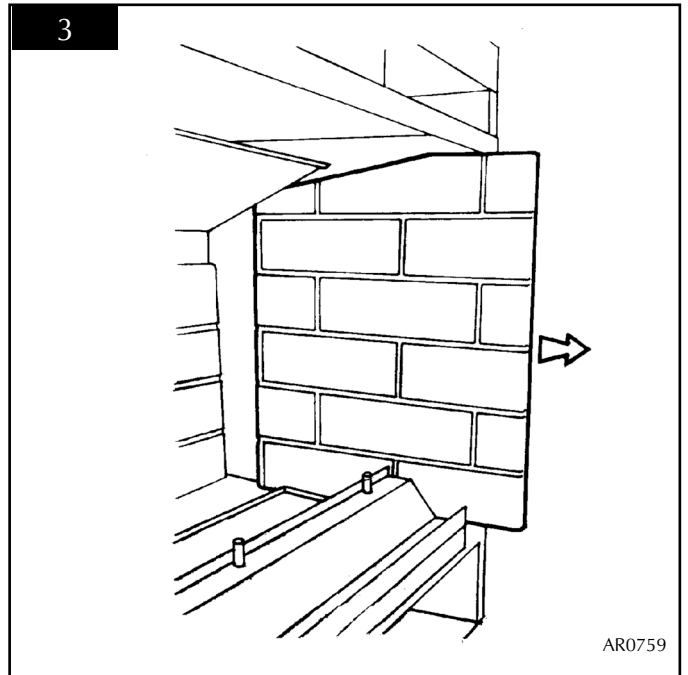

HAVE YOU ISOLATED THE GAS SUPPLY?

- f) Disconnect the isolating device from the appliance inlet pipe so as to leave the gas supply isolated.
- g) If the appliance has been upgraded to a remote control, disconnect the leads from the top left hand corner of the gas valve. See diagram 4.

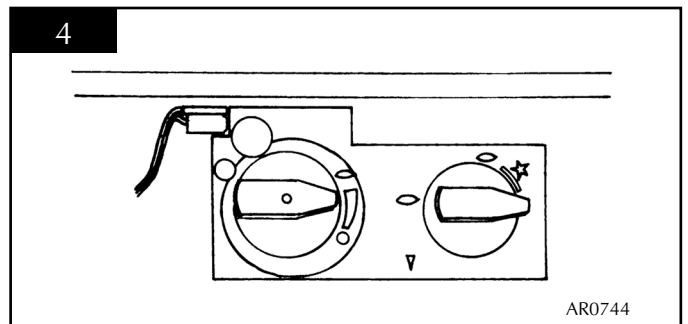

- h) Remove the screws retaining the log support. See diagram 5.

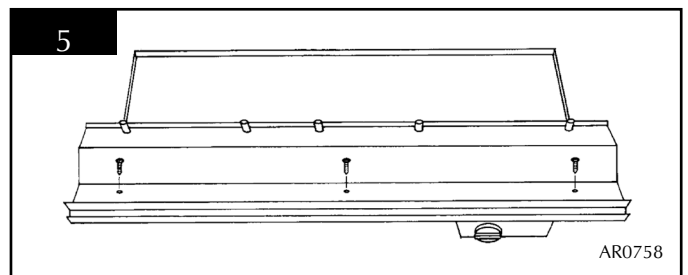

SERVICING INSTRUCTIONS

REPLACING PARTS

- i) Remove the two screws at the front of the burner tray and loosen the screw at the rear. See diagram 6.

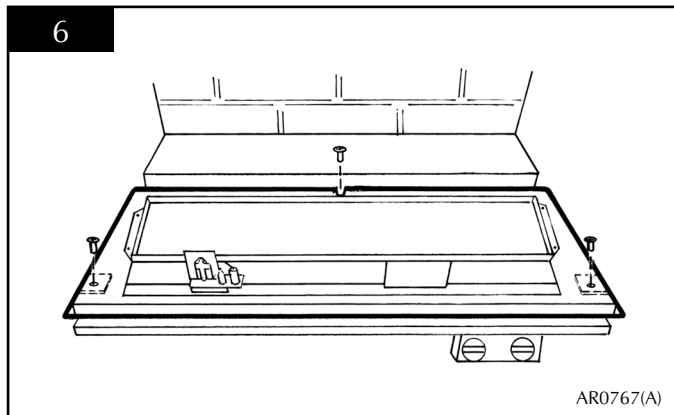

- j) Hold the burner tray at the front, pull forward and rotate upwards. The unit can now be serviced.
k) When replacing the unit ensure the location tabs engage under the divider plate. See diagram 7.

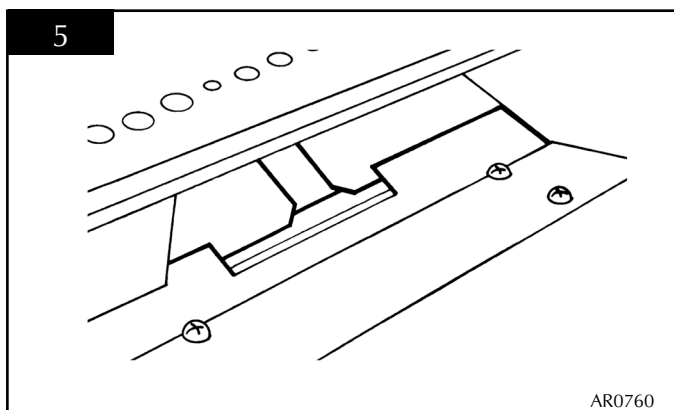

3. MAIN BURNER

- 3.1 With the module removed as in Servicing Instructions section 2.1, undo the injector nut. Remove the thermocouple from the rear of the gas valve.
3.2 Remove the pilot pipe from the pilot unit and the gas valve. See diagram 8. Pull the ignition lead off the electrode. Turn

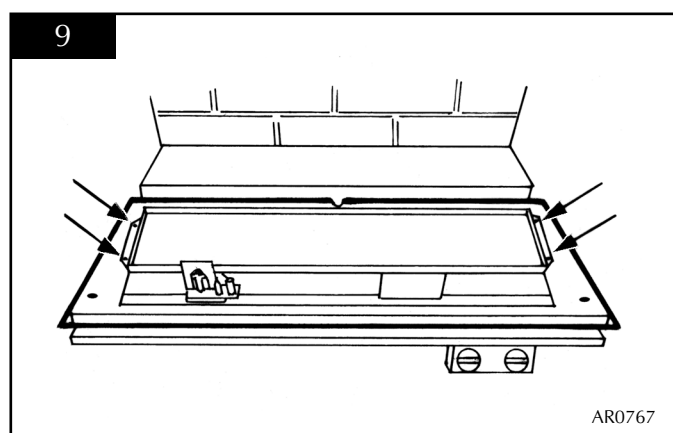
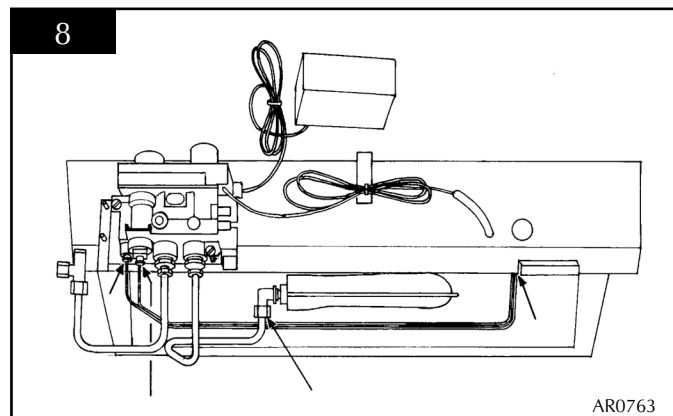

- 3.3 To replace the burner, align the injector with the feed pipe and loosely attach the nut. Replace the four screws and tighten the injector nut. Replace the thermocouple, pilot pipe and ignition lead.
3.4 When replacing the module ensure the thermocouple, feed pipe and pilot pipe engage in the divider plate slot. See diagram 10. Check for leaks.

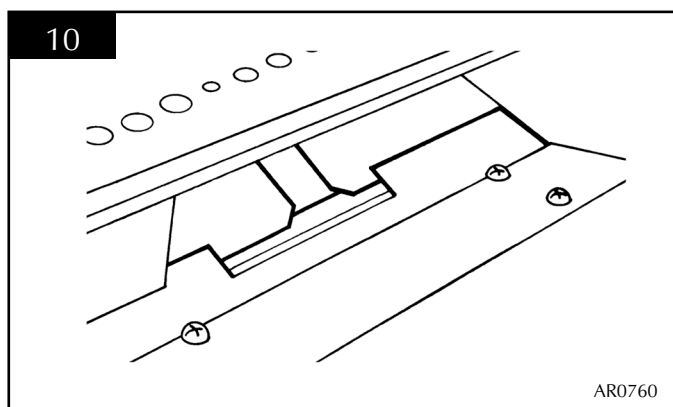

SERVICING INSTRUCTIONS

REPLACING PARTS

4. PILOT UNIT

- 4.1 Undo the compression nut on the pilot burner then undo the thermocouple at the rear of the gas valve. Carefully cut the cable ties holding the thermocouple to the pilot pipe. Remove the HT lead from the electrode, undo the two retaining screws and remove the pilot. See diagram 11.

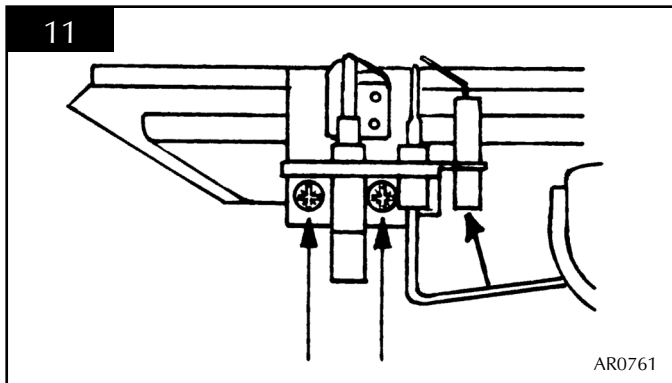

- 4.2 When replacing the pilot ensure the thermocouple follows its original route, i.e. along the pilot pipe. Attach the thermocouple to the pipe with new cable ties.
- 4.3 Set the spark gap. See diagram 12.

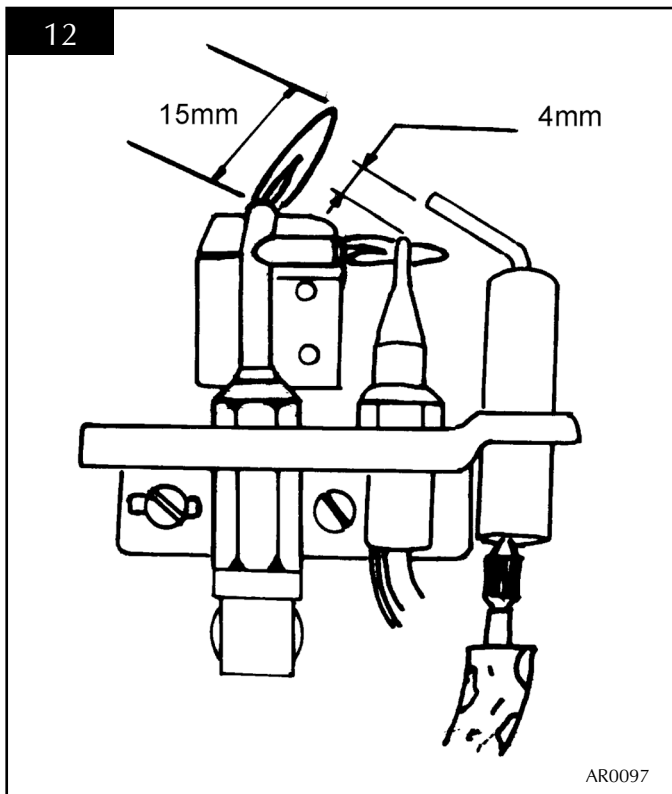

5. IGNITION LEAD

- 5.1 Gain access to the pilot assembly, (see section 2) and disconnect the ignition lead from the electrode.
- 5.2 Remove the front cover from the control valve, (see diagrams 13 and 14), disconnect the other end of the ignition lead from the valve body, note the existing route of the ignition lead.

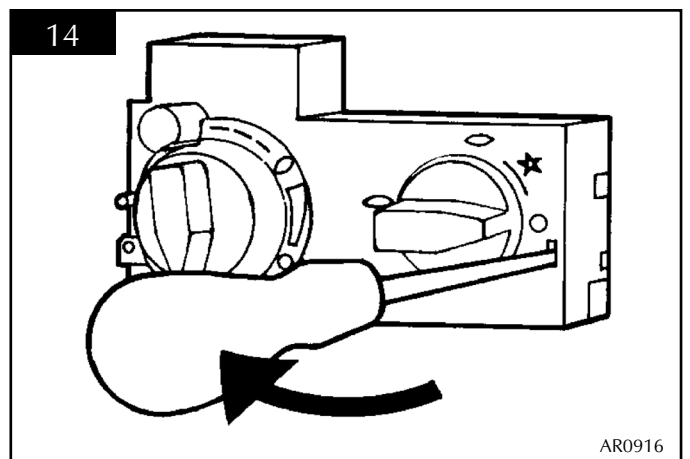
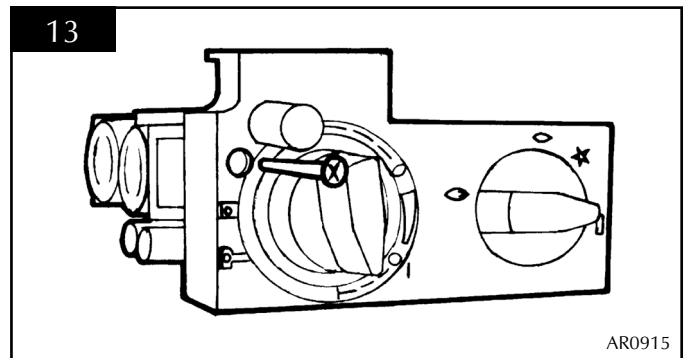

- 5.3 Replace with a new ignition lead following the same route as the old one. Replace the valve cover and the pilot assembly.
- 5.4 Check the operation of the new ignition lead.

6. PIEZO

- 6.1 The piezo assembly used on this appliance is not serviceable and is unlikely to fail.
- 6.2 If a new piezo is required it will be necessary to change the gas valve. Refer to Section 7.

SERVICING INSTRUCTIONS

REPLACING PARTS

7. GAS VALVE

- 7.1 Remove the burner module as described in Servicing section 2.1.
- 7.2 Disconnect the 2 x 8mm and 1 x 4mm gas pipe fittings at the back of the gas valve and also disconnect the thermocouple. See diagram 15.

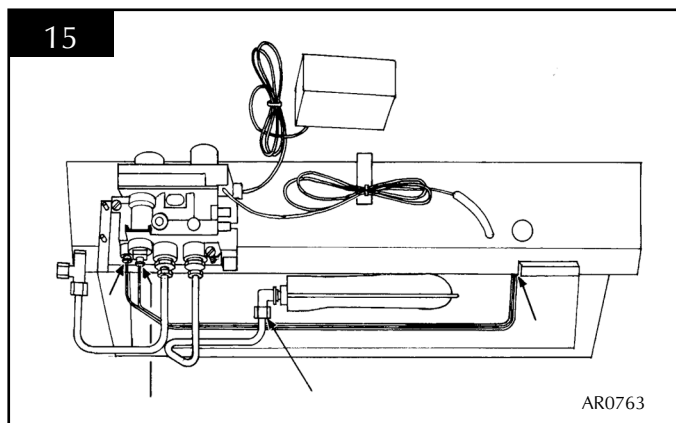

- 7.3 Undo the single screw that secures the left-hand side of the control cover. See diagram 16.

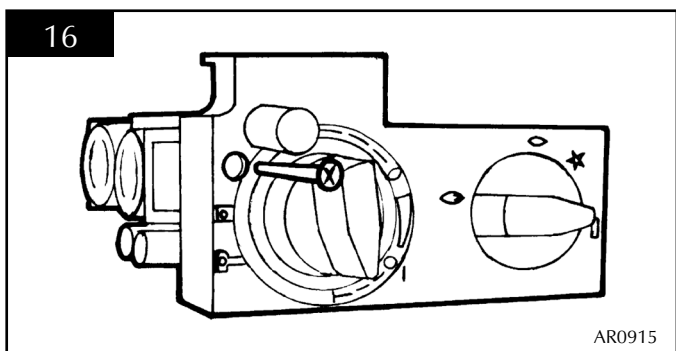

- 7.4 To release the right-hand side of the control cover insert the narrow blade screwdriver into the slot shown in diagram 17, lever it gently and pull from the right-hand side at the same time. The cover will now come off, there is a small cylindrical metal spacer inside the cover, this must be kept and replaced on the fixing screw during re-assembly.

NOTE: If this appliance has been upgraded to remote control, the small metal spacer will have been replaced by a motor.

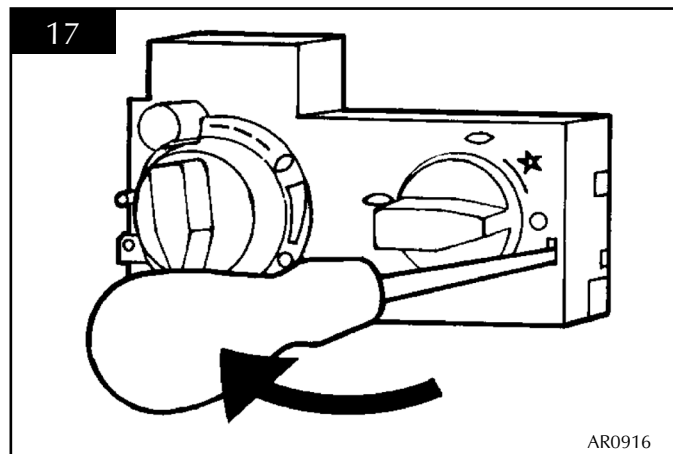

- 7.5 Disconnect the ignition lead from the gas valve.
- 7.6 Undo the two bolts securing the gas valve to the appliance and remove the valve.
- 7.7 Replace in reverse order.
- 7.8 Check all joints for gas leaks, check the operation of the thermocouple and ignition lead.

8. MAGNETIC SAFETY VALVE

- 8.1 Remove the burner module as described in Servicing section 1.4. Undo the thermocouple connection from the back of the gas valve.
- 8.2 Undo the mag valve retaining nut at the back of the control valve, gently tap out the mag valve and replace with a new unit. Replace the retaining nut and tighten. See diagram 18.

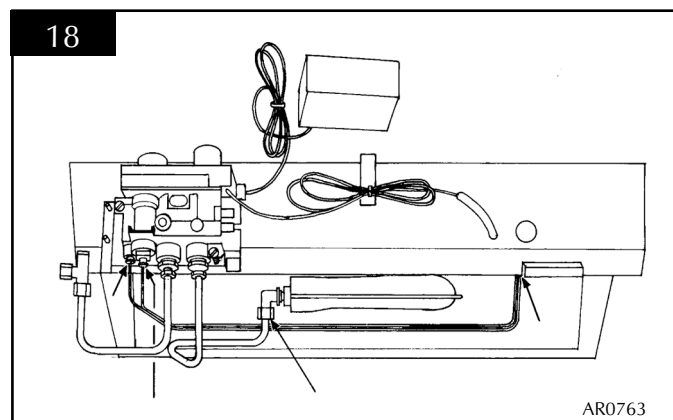

- 8.3 Reassemble the thermocouple into the rear of the valve. **DO NOT OVERTIGHTEN.** Check for leaks after reassembly.

SERVICING INSTRUCTIONS

REPLACING PARTS

9. MAIN INJECTOR

- 9.1 Remove the burner module as described in Servicing section 2.1. Disconnect the pipe from the injector and the gas valve. See diagram 19.

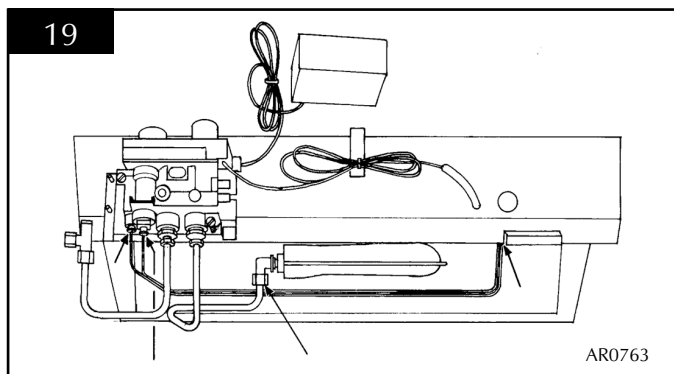

- 9.2 Rotate the injector until it is fully removed, and install the correct replacement injector. Re-assemble and turn the gas supply on, check for any leaks.

10. PRIMARY AERATION PLATE

NOT ALL MODELS HAVE AERATION PLATES. REFER TO NOTE AT BEGINNING OF INSTALLATION INSTRUCTIONS.

- 10.1 Remove the burner module as described in Servicing section 2.1.
- 10.2 Remove the fixing screw and slide the plate off the venturi.
- 10.3 Replace with the correct size plate and secure with the screw. Ensure the lower edge of the plate is located over the venturi flange. See diagram 20.

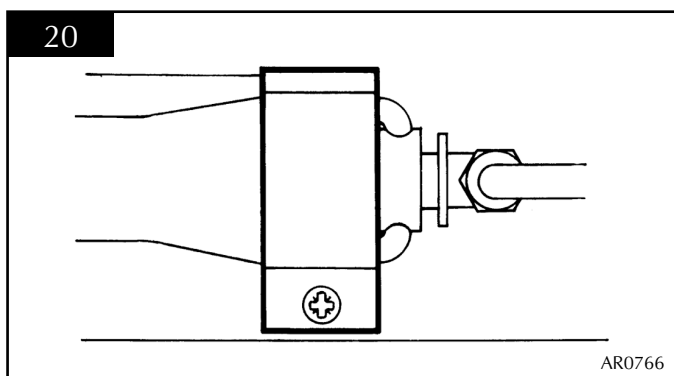

11. CHANGING BETWEEN GAS TYPES

In order to change between gas types, it will be necessary to change the following items:

- Burner Unit
- Pilot Unit
- Control Valve
- Injector
- Aeration Plate (if required)
- Databadge

A kit of parts is available for this, always quote the Model number and Serial number when ordering any spare parts.

NOTE: THE CONTROL VALVE IS FACTORY PRESET FOR THE CORRECT GAS TYPE AND MODEL, A NEW UNIT WILL NEED TO BE ORDERED WHEN CHANGING BETWEEN GAS TYPES.

12. CONTROL UPGRADE

See Installation Instructions, section 1.

13. DEBRIS DEFLECTOR INSPECTION

13.1 To remove the module the procedure is as follows:

- a) Remove the outer surround, see diagram 21.

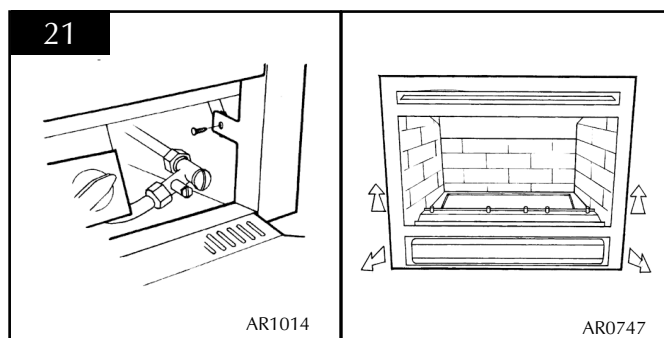

- b) Remove the glass frame. See diagram 22, arrow A.

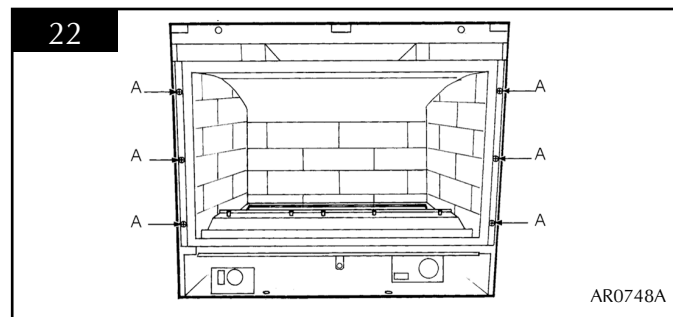

- c) Remove the ceramic logs.
- d) Remove the granules.
- e) Carefully slide the side panels forward and store safely. (These are very fragile). See diagram 23

SERVICING INSTRUCTIONS

REPLACING PARTS

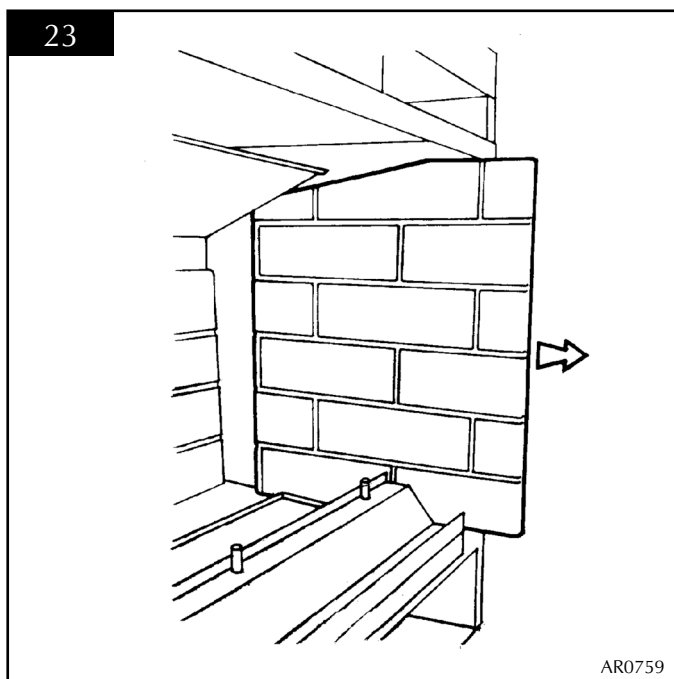

HAVE YOU ISOLATED THE GAS SUPPLY?

- f) Disconnect the isolating device from the appliance inlet pipe so as to leave the gas supply isolated.
- g) To remove the main burner:
 - Undo the three screws, Diagram 24
 - Pull the unit out

For more detail, see *Replacing Parts, Removing the Burner Module*.

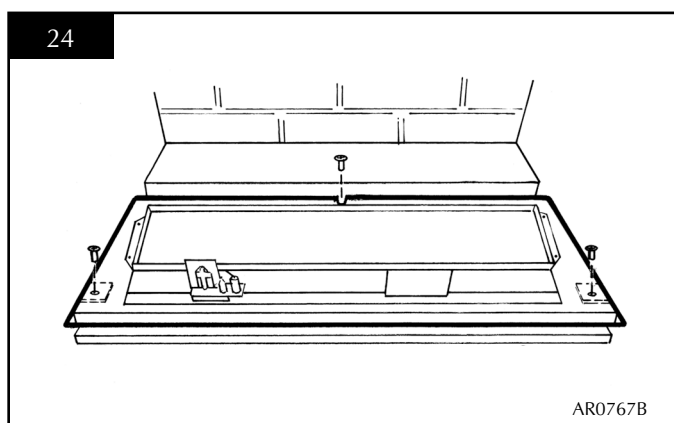

- h) Remove the four screws securing the inner to the outer box and undo the two screws behind the rear ceramic panel. Diagram 25.

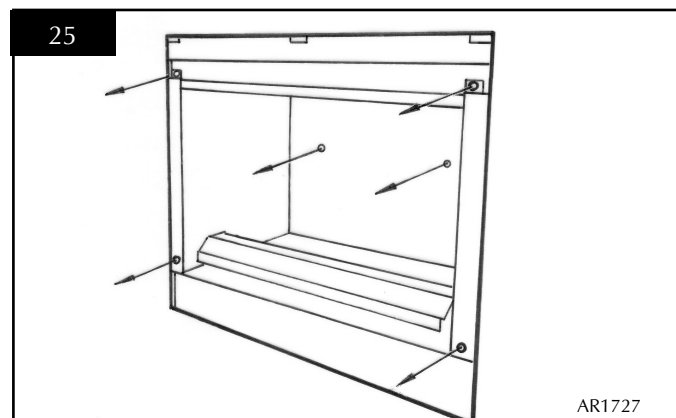

- i) Slide the inner box away from the outer box by pulling it forward. Diagram 26.

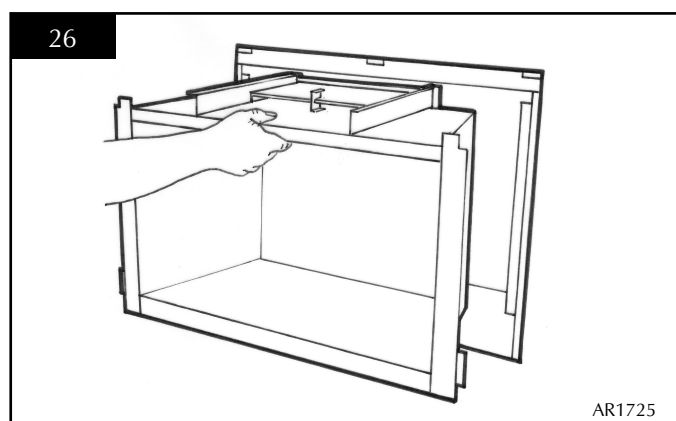

- j) Undo the eight screws securing the flue spigot plate to the inside top surface. See Diagram 27.

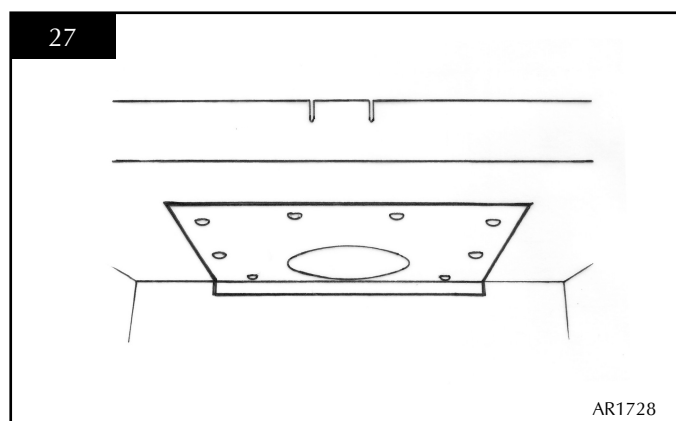

- k) Pull the debris deflector down and out of the chimney and inspect the space immediately above the appliance for a build up of debris. See Diagram 28.

SERVICING INSTRUCTIONS

REPLACING PARTS - RIVA 67

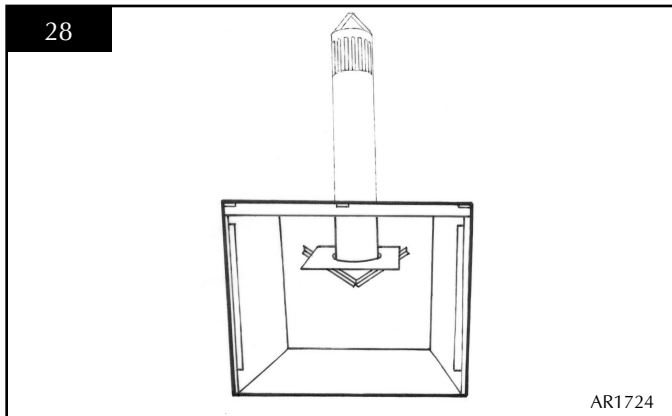

k) Inspect the debris deflector for damage and replace if necessary. Check the seal is intact, see *Servicing Requirements, Section 1* and replace if necessary.

13.2 Follow these instructions in reverse order to reassemble the appliance.

SERVICING INSTRUCTIONS

REPLACING PARTS

14. SHORT SPARES LIST

Component	RIVA 67		RIVA 53	
	NG	LPG	NG	LPG
PILOT	PI0044	PI0045	PI0044	PI0045
INJECTOR	IN0007	IN0040	IN0028	IN0040
BURNER UNIT	GZ3124	GZ3125	GZ4321	GZ4322
AERATION PLATE	Nat Gas		Nat Gas	
	G20		G20	
	GZ3867		GZ3966	
	LPG		LPG	
	G30	G31	G30	G31
	N/A	GZ2003	GZ3865	GZ4333
GAS VALVE*	GC0088			
MAG UNIT	GC0092			
IGN LEAD	GC0090			
CERAMIC LINERS	BLACK RIBBED	BRICK EFFECT	BLACK RIBBED	
REAR CERAMIC PANEL	CE0345	CE0326	CE0385	
L/H CERAMIC PANEL	CE0346	CE0327	CE0450	
R/H CERAMIC PANEL	CE0347	CE0328	CE0450	
GRANULES	CE0424		CE0423	
LOG SET	CE0306		CE0415	
LOG 1	CE0307		CE0416	
LOG 2	CE0308		CE0417	
LOG 3	CE0309		CE0418	
LOG 4	CE0310		CE0419	
LOG 5	CE0311		CE0420	
LOG 6	CE0312		CE0421	
LOG 7	CE0313		CE0422	
STANDARD UPGRADE KIT			8455	
TIMER/THERMO. UPGRADE KIT			8456	
CONVECTION FAN KIT			8571	
DUCT KIT			8572	
WINDOW FRAME ASSEMBLY	GZ3111		GZ4310	
DEBRIS DEFLECTOR KIT	8736		N/A	

* Gas Valve is pre-set for the appliance

SERVICE RECORDS

1ST SERVICE

Date of Service:.....
Next Service Due:.....
Signed:.....
Dealer's Stamp/CORGI Registration Number

3RD SERVICE

Date of Service:.....
Next Service Due:.....
Signed:.....
Dealer's Stamp/CORGI Registration Number

5TH SERVICE

Date of Service:.....
Next Service Due:.....
Signed:.....
Dealer's Stamp/CORGI Registration Number

7TH SERVICE

Date of Service:.....
Next Service Due:.....
Signed:.....
Dealer's Stamp/CORGI Registration Number

9TH SERVICE

Date of Service:.....
Next Service Due:.....
Signed:.....
Dealer's Stamp/CORGI Registration Number

2ND SERVICE

Date of Service:.....
Next Service Due:.....
Signed:.....
Dealer's Stamp/CORGI Registration Number

4TH SERVICE

Date of Service:.....
Next Service Due:.....
Signed:.....
Dealer's Stamp/CORGI Registration Number

6TH SERVICE

Date of Service:.....
Next Service Due:.....
Signed:.....
Dealer's Stamp/CORGI Registration Number

8TH SERVICE

Date of Service:.....
Next Due:.....
Signed:.....
Dealer's Stamp/CORGI Registration Number

10TH SERVICE

Date of Service:.....
Next Service Due:.....
Signed:.....
Dealer's Stamp/CORGI Registration Number

Gazco Limited, Osprey Road, Sowton Industrial Estate, Exeter, Devon, England EX2 7JG
Tel: (01392) 261999 Fax: (01392) 444148 E-mail: info@gazco.com

A member of the Stovax Group