

FOCAL
POINT
FIRES plc

Versailles

Coal Effect Gas Fire

PATENT PENDING

INSTALLATION, SERVICING AND USER INSTRUCTIONS

All instructions must be handed to the user for safekeeping

Revision A-08/00

Country(s) of destination GB, IE

Focal Point Fires plc, Avon Trading Park, Christchurch, Dorset BH23 2BT

Tel. (01202) 499330

Fax. (01202) 499326

www.focalpointfires.co.uk

e-mail: sales@focalpointfires.co.uk

CE

plc



INSTALLATION INSTRUCTIONS

Preliminary Notes Before Installation

This appliance is an Inset Live Fuel Effect appliance which provides radiant and convected warmth utilising the latest type burner technology.

The fire is designed to fit various types of fireplaces and natural flues as listed in the Installation Requirements.

The appliance must be installed by a competent person in accordance with Gas Safety (Installation and Use) Regulations 1998. It is strongly recommended that a CORGI registered engineer be used for this purpose.

Read all these instructions before commencing installation.

This appliance must be installed in accordance with the rules in force and only used in a sufficiently ventilated space.

The appliance is designed for installation on to a non-combustible hearth of at least 300 mm depth.

This appliance is factory set for operation on the gas type and at the pressure stated on the appliance data plate.

<i>Section</i>	<i>Contents</i>	<i>Page No.</i>	<i>Section</i>	<i>Contents</i>	<i>Page No.</i>
1.0	Important Notes	1	8.5	Fitting the Burner Tray	8
2.0	Appliance Data	2	9.0	Fuel Bed Layout	8
3.0	Installation Requirements	2	10.0	Fitting the Fireframe/Hood	10
4.0	Site Requirements	3	11.0	Testing and Commissioning	10
4.1	Debris Collection Space	4	11.1	Operating the Appliance	10
5.0	Ventilation	4	11.2	Spark Failure	10
6.0	Flue Box	5	11.3	Setting Pressure	11
7.0	Unpacking the Appliance	5	12.0	Spillage Monitoring System	11
7.1	Component Checklist	6	12.1	Testing for Spillage	11
8.0	Installation of Appliance	6	13.0	Fitting the Firefront	12
8.1	Preparing the Appliance	6	14.0	Briefing the Customer	12
8.2	Preparing the Opening	6	15.0	Servicing	12
8.3	Gas Supply Routing	7	16.0	Troubleshooting Guide	14
8.4	Cable Fixing	7			

1.0 IMPORTANT NOTES

This fire is an Inset Live Fuel Gas Fire providing radiant and convected warmth. It is designed to operate on Natural Gas.

It is the LAW that all gas appliances and fittings are installed by a competent person (such as a CORGI registered fitter) and in accordance with the Gas Safety (Installation and Use) Regulations 1998, the relevant British Standards for Installation, Codes of Practice and in accordance with the Manufacturers' Instructions. The installation shall also be carried out in accordance with the following regulations:

The Building Regulations issued by the Department of the Environment the Building Standards (Scotland) (Consolidation) Regulations issued by the Scottish Development Department.

BS 5871 part 2

BS 5440 part 1

BS 1251

BS 6891

BS 6461 part 1

Note: For Republic of Ireland, reference should be made to the relevant standards governing installation, particularly in regard to flue sizing and ventilation. See IS813, ICP3, IS327 and any other rules in force.

Failure to comply with these regulations could lead to prosecution and deem the warranty invalid.

This appliance must be installed in accordance with the rules in force and used only in a sufficiently ventilated space.

This appliance is free from any asbestos material. Refractories and coal bed are constructed from ceramic fibre.

2.0

APPLIANCE DATA

Gas Group	G20 Natural Gas CAT I2H
Inlet Pressure	20 mbar
Max Energy Input (gross)	6.0 kW
(nett)	5.4kW
Min Energy Input (gross)	3.5 kW
(nett)	3.15kW
Pilot Energy Input (gross)	210 W
(nett)	190W
Setting Pressure (high)	15.9 mbar
(low)	5.8 mbar
Main Burner Injector	Stereo size 77
Gas Inlet Connection	8 mm compression
Ignition	Piezo spark
Spark Gap	3.5 to 4.5 mm
Weight	20 Kg
Efficiency Class	Class 2

Please see Data Badge affixed to appliance for current data.

This appliance is for use only with the gas type and at the pressure stated on the appliance Data Badge.

3.0

INSTALLATION REQUIREMENTS

The appliance MUST NOT be installed into a room containing a bath or shower, or where steam may be present. The fire has been designed to fit into a builder's opening or fireplace conforming to BS 1251 (and meeting certain dimensional requirements) or a suitable flue box complying with the constructional requirements of BS 715. The flue box must be installed onto a suitable non-combustible insulating surface at least 12 mm thick, covering the entire base area of the box.

The flue must have an effective height of at least three metres as measured from the hearth to the top of the flue. Any flue damper plates or restrictors should be removed and no other restriction fitted to the flue. Where removal is not practical the restriction must be fixed in the fully open position.

A natural draught flue system is required and if previously used for solid fuel or oil burning the flue and chimney must be swept prior to appliance installation. Pre-cast flues must be checked for mortar fangs and correct installation of joints, flue sections in loft space and terminals. The flue must be checked before installation by using a smoke pellet or similar to ensure proper draw and that leakage is not evident at any joint. Repair and re-test as necessary before the appliance is installed.

The flue must be connected to only one fireplace and the flue must not vent more than one appliance (i.e. not shared with a gas back boiler). There must be no opening in the flue apart from one that the appliance is installed into and the one venting the gases into the air. A suitable terminal may be fitted, such as class GC1, as regulations allow.

This appliance has been tested for use in a pre-cast block flue complying with BS 1289. In accordance with BS 1289 part 1, pre-cast flues built with directly plastered faces (front or rear) are not correctly installed as to ensure proper operation with any type of gas fire. In some instances of this flue construction temperature cracking of the surface plaster may occur through no fault of the appliance. An air gap or some form of insulation material should be installed to prevent normal flue temperatures from damaging wall surfaces.

This appliance is suitable for use with a "lightweight" surround and back panel of 150C minimum rating when installed with a 20 mm spacer frame available from Focal Point Fires plc. Part Number FB004210/0.

4.0 SITE REQUIREMENTS

The fireplace opening should be constructed of non combustable material. It should be inspected and repairs made where necessary. Any chair brick or fireback may be left in situ providing that the dimensional requirements for debris collection space and spigot clearances are met.

The opening **WIDTH** and **HEIGHT** dimensions should be between 385 mm and 440 mm wide (365 mm with optional 20 mm spacer frame) and between 545 mm and 575 mm high. For flues previously used with solid fuel the minimum **WIDTH** is 380 mm.

Opening **DEPTH** should be 145 mm or greater for a clay/cement lined or pre-cast flue which is new, unused or previously only used with a gas fire. **DEPTH** should be 185 mm or greater for a flue which has previously been used for a solid or oil burning appliance. Opening **DEPTH**s include any plaster or infill panels which form part of the installation.

This appliance requires a natural draught flue system which may be one of the following;

225 mm x 225 mm (9in x 9in) brick or stone

125 mm (5in) minimum diameter lined brick or stone

125 mm (5in) minimum diameter twin wall flue conforming to BS 715.

Pre-cast block flue complying with BS 1289.

Any existing under grate draught device must be sealed off.

The opening wall must be non-combustible.

The appliance requires a hearth with non-combustible surface of at least 12 mm thick. The top surface must be at least 50 mm above the surrounding floor level or be surrounded by a raised edge or fender 50 mm high.

To enable the product of combustion to be cleared properly up the flue the outlet at the top of the appliance must have a 50 mm minimum clearance between it and the back wall of the opening or any other obstruction. The area immediately above the outlet must form a smooth path into the flue.

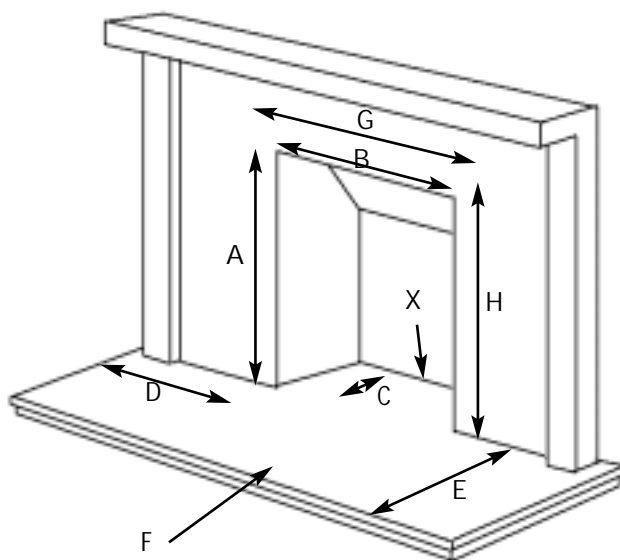

Italics refer to spacer fitment

A. Opening height: 545mm/575mm max.

B. Opening width: 380mm (*365mm*) min/440mm max.

C. Mounting depth: 125mm. (*105mm*)

D. Hearth must extend minimum of 150mm either side of the opening.

E. Hearth must extend minimum of 100mm in front of the firebed.

F. Non-combustible hearth must be a minimum of 50mm in height or be surrounded by a 50mm high fender.

G. 470mm: This area must be flat and vertical to allow good frame sealing.

H. 585mm: This area must be flat and vertical to allow good frame sealing.

X. See section 4.1

4.0 SITE REQUIREMENTS (continued)

Any type of fire surround used with this appliance must be adequately sealed to the wall and floor. A combustible shelf may be fixed to the wall above the fire providing that it complies with the dimensions given below.

<i>Maximum depth of shelf</i>	<i>Minimum distance from inside edge of fire to underside of shelf</i>
100mm (4in)	203mm (8in)
150mm (6in)	305mm (12in)
203mm (8in)	356mm (14in)

A non-combustible shelf may be fitted to within 10mm of the top edge of the fireframe.

Combustible materials, such as wood, may be fitted to within 100mm (4in) of either side of the fireplace opening; providing the forward projection does not exceed 100mm (4in).

Any combustible side walls must be at least 500mm to the side of the radiant heat source.

As with all heating appliances any decorations/soft furnishings and all coverings (i.e. flock, blown vinyl and embossed paper) positioned too close to the appliance may discolour or scorch.

4.1 DEBRIS COLLECTION SPACE

The mounting depth of this appliance is 125mm.

In accordance with BS 5871 part 2 minimum debris collection volumes are required behind the installed appliance. These are shown in the table below and as dimension X on the fireplace diagram shown previously.

CLAY/CEMENT LINES OR BLOCK FLUE WHICH IS NEW, UNUSED, OR PREVIOUSLY ONLY USED WITH A GAS FIRE.

X Dimension = 20mm

UNLINED FLUE OR CHIMNEY WHICH HAS BEEN PREVIOUSLY USED FOR A SOLID FUEL OR OIL BURNING APPLIANCE.

X Dimension = 60mm

5.0 VENTILATION

No purpose provided ventilation is normally required for this appliance. The requirements of other appliances operating in the same room or space must be taken into consideration when assessing ventilation.

If spillage is detected when commissioning the appliance then amongst other problems there may be insufficient natural ventilation for correct operation of the flue. If the appliance does not spill with the windows open, but spillage is detected with the windows closed, this demonstrates a lack of natural ventilation. If spillage is still detected with the windows open the flue is at fault. Installation of an air brick is the best solution to lack of ventilation. Any ventilation fitted must comply with BS 5871 part 2 and BS 5440 part 2. Ventilation fitted under or within immediate vicinity of the appliance must not be used as it may adversely affect performance of the ODS system.

Spillage detected during commissioning is almost always a result of poor flue performance that cannot be corrected by any amount of ventilation.

For Republic of Ireland ventilation may be required, see IS 813, ICP3, IS 327 and any other rules in force.

6.0 PREFABRICATED FLUE BOXES

This appliance can be fitted into a number of proprietary flue boxes provided that the minimum dimensions given in the diagram below are complied with.

Constructional Note: *The frame of the fire any back panel or other infill panels and the flue box must be sealed together so that there is no possibility of leakage between them. Adequate clearances to combustible materials (e.g. false chimney breast construction) must be maintained.*

The manufacturers instructions for fitting the prefabricated box shall be complied with at all times.

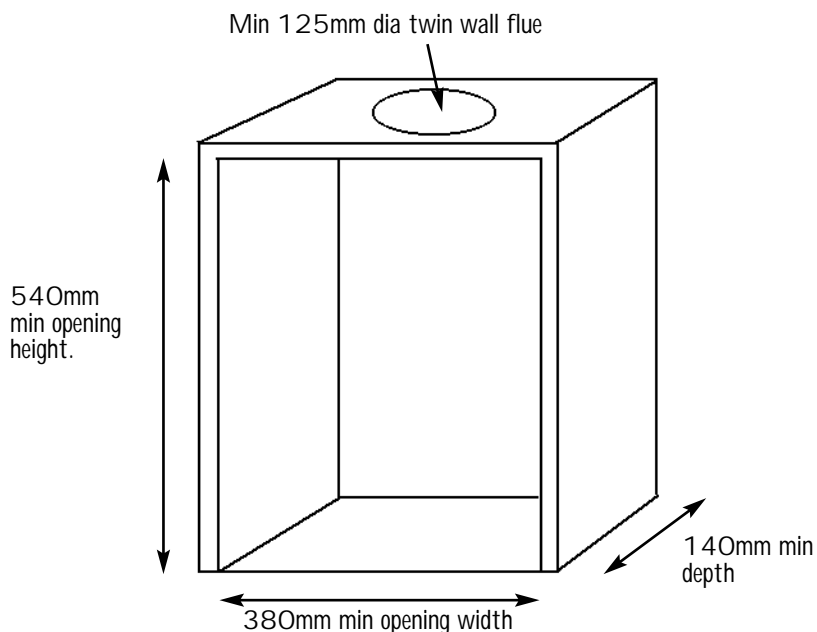

The fire box base and hearth must have a non combustible surface of at least 12 mm thick. The top surface of which must be 50 mm above the surrounding floor or be surrounded by a raised edge or fender 50 mm high.

The top 200 mm of the fire box must be securely insulated with a minimum of 30 mm thick rockwool or similar. A minimum air gap must be maintained between any part of the fire box or flue and any combustible materials.

To fit the fire using the cable fixing kit some minor adaptation may be necessary for certain flue boxes.

A check should be made to ensure the firebox does not obscure the flue box outlet.

The firebox base of the flue box and hearth below may be drilled to allow plugs and screws to secure installation.

It is important that the sealing requirements of the appliance are met at all times and that the flue box is well sealed to any back or infill panel.

7.0 UNPACKING THE APPLIANCE

Stand the carton the right way up, cut the strapping bands and remove the top endcap. Read all the instructions before continuing to unpack or install this appliance.

Remove the box containing the cast front fret and the box containing the ceramic coals and other ceramic firebed components. Remove the cardboard packing pieces and any other bags or boxes containing fittings or other parts. When all loose parts have been removed the outer sleeve may be lifted off to reveal the appliance. Check that the components supplied correlate with the component checklist given in section 7.1. Please dispose of all the packaging materials at your local recycling centre.

7.1 COMPONENT CHECKLIST

<i>QUANTITY</i>	<i>DESCRIPTION</i>
1	Firebox and burner tray assembly
1	Decorative frame - 3 piece
1	Convection hood
1	Cast front fret with separate ashpan door
1	Moulded ceramic fibre combustion matrix
14	Individual ceramic coals (5 moulded and 9 broken)
2	Ceramic fibre side cheeks
1	Ceramic brick panel
1	Cable fixing kit; 2 cables, 2 tensioners, 2 cable clamps, 4 fixing eyes, 4 rawlplugs
1	Sealing grommet
1	Length of adhesive sealing strip
1	Self tapping screw pack; 2 No 8 x 5/16
1	Deflector baffle
1	Set of manufacturers instructions and warranty card
1	Gas supply routing template

8.0 INSTALLATION OF APPLIANCE

Note: Ensure that the gas supply is isolated before commencing installation of the appliance.

The fireplace opening and environment must be in compliance with specifications laid down in the appropriate sections of these instructions.

8.1 PREPARING THE APPLIANCE

Remove the appliance from its carton as described previously and stand on a dust sheet or similar. Place the coals, ceramics and fixing safely to one side.

Remove the burner from the assembly by removing the two screws in the data/control plate. Lift away the plate, and remove the two screws retaining the tray legs. The tray is now free and may be lifted away.

Knock out holes are provided in the rear of the convector box for use where concealed pipework is required. Knock out the appropriate holes with a sharp tap from a hammer and fit the rubber grommet supplied. A small incision can now be made in the rubber to slip snugly around the outside of the supply pipe and sleeving.

Note: DO NOT install or use the appliance without this seal in place.

If the hole is inadvertently opened reseal with an intact grommet. Failure to fit this seal correctly will cause the flue suction to act upon the area under the burner resulting in poor performance.

8.2 PREPARING THE OPENING

Before installing the fire check the flue for correct operation using a smoke pellet. All of the smoke should be drawn up the flue and exit correctly from the terminal. If problems are found DO NOT fit the fire until corrective action is completed.

Protect the decorative hearth whilst pushing the convector box in and out of the opening. Part of the packaging is an ideal hearth saver pad.

Before running the gas supply into the opening offer up the convector box to the fireplace to check the fit is good. Ensure that it slides in correctly, the sealing face sits flat and square to the wall or infill panel

8.2 PREPARING THE OPENING (continued)

and that the base is firm in the floor of the opening as no leaks are permissible here. At this stage it is essential to ensure that the spigot outlet of the fire is not obstructed in any way. Remove the convector box and take any necessary measurements before making good and preparing for final installation. Apply the self adhesive strip around the rear edge of the firebox at approximately 5mm in from the edge.

Cable fixing: For fixing the fire by the cable method, see relevant section.

Fixing by screw: Mark and drill the fireframe or base and relevant points in the opening or on the wall. Use the convector box as a template to position the holes. Rawlplugs will be required.

NOTE: Plastic rawlplugs are not suitable for this application.

Gas supply: Following preparation for the fixing method the concealed gas supply (if required) can now be put into place. Refer to the relevant section for suggested pipe routes. The ends of the sleeving in which the gas pipe is run should be sealed. The end of the 8mm pipe should be temporarily sealed to prevent the ingress of debris during fixing.

8.3 GAS SUPPLY

When the opening is ready for installation of the fire the gas supply can be routed as shown in the following diagrams.

An isolator cock or restrictor elbow must be fitted to the incoming supply to facilitate servicing.

If using a concealed supply it should be laid in accordance with the diagram below. Select the supply route most relevant to the entry point of the gas supply into the fireplace opening.

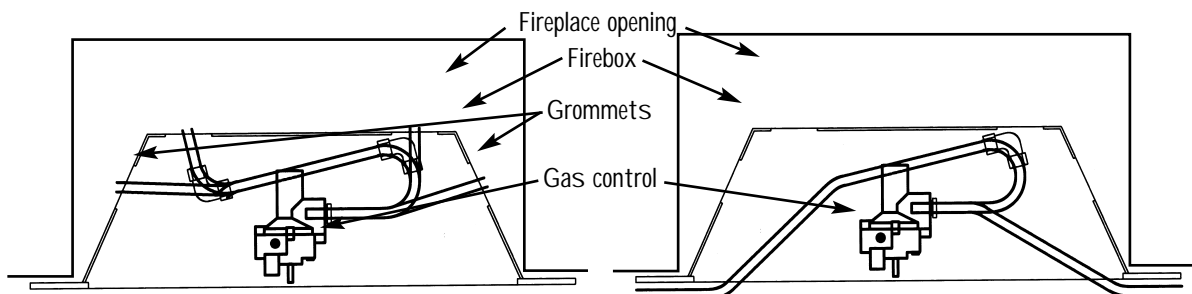

If using an across the hearth connection then the firefront is notched and the supply pipe can be routed through this. The open end of the gas supply pipe should be temporarily sealed to prevent ingress dust and dirt during installation.

8.4 CABLE FIXING

Drill four holes as shown in the diagram and fit the fibre rawlplugs. If the fireplace does not allow for the exact layout shown the eyebolts should be fixed to give a similar configuration as possible.

Thread both tensioning cables through the holes at the top of the firebox, both eyelets and back through the lower holes in the firebox as shown in the photograph. Before finally fitting the firebox apply the self-adhesive sealing strips around the rear of the firebox frame. Holes at the top and bottom of the firebox for cable fixing required.

Push the appliance back into the fireplace, centralise and pull the loose cables through the holes into the firebox.

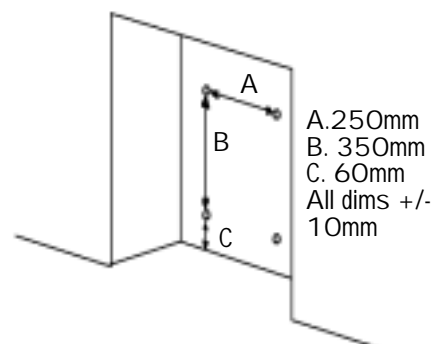

8.4 CABLE FIXING (continued)

Thread the cable tensioners onto the cables as shown with the nuts screwed down close to the tensioner head.

Slide the screwed nipple onto the cable, pull cable taut and tighten nipple.

Adjust tensioner using a suitable spanner to pull the appliance back into position to allow an even seal around the fireplace opening.

Visually inspect the seal and repeat if necessary.

Surplus tension cable **MUST NOT** be cut off as this will prevent proper installation after servicing. Coil up the surplus cable and tuck the coils out of the way as suggested in the photograph.

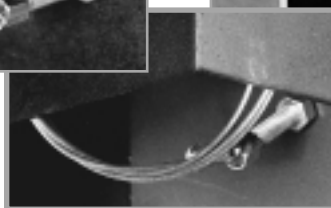

8.5 FITTING THE BURNER TRAY

Important Note: Check that the thermocouple nut connection into the rear of the valve is secure.

Temporarily fit the burner tray and ensure a suitable gas route can be achieved. Place the burner tray into the convector box making sure that the rear lugs locate properly on the ledge in the firebox.

Fit the two securing screws through the tray legs to secure the assembly.

Connect the gas supply and tightened the gas connections.

Fit the data/control plate to the tray using the two screws provided. Ensure that the control knob can be pushed fully in and does not touch the plate.

Fit the deflector baffle to the two locations on the front face of the firetray. Screws are provided for this purpose. The baffle should be level with the lower edge of the tray. Place the front fret in front of the fire temporarily to check the angle of the baffle. The fret should fit well and the control devices beneath should not be visible to the eye. Realign the baffle if necessary to achieve the correct fit.

IMPORTANT NOTE. If the Elysee fret is fitted to the appliance the deflector baffle should **NOT** be fitted.

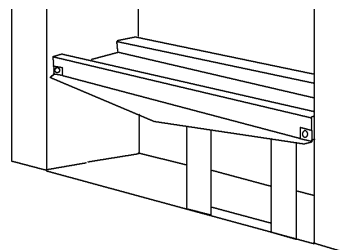

9.0 FUEL BED LAYOUT

Place the brick panel against the rear of the firebox.

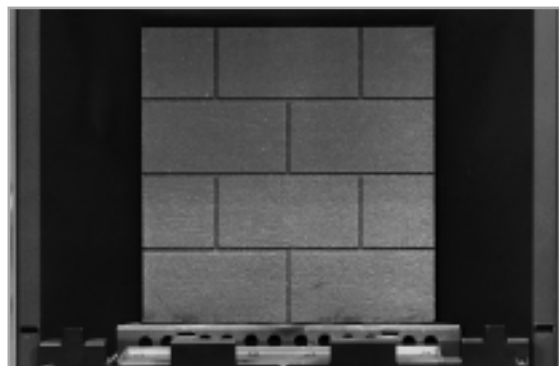

9.0

FUEL BED LAYOUT (continued)

Place the ceramic combustion matrix onto the burner and the ceramic side cheeks onto the matrix.



Place the front row of 5 moulded coals onto the matrix, equally spaced across the width of the fire. They may be at any rotational orientation desired. Ensure their rear edges do not overhang the flame ports. Corners or rough edges **MUST NOT** be allowed to enter the flame ports.



Place the centre row of four coals, making sure that they do not fall down into the flame port but bridge across the spaces as shown. Rotational orientation may be as desired.

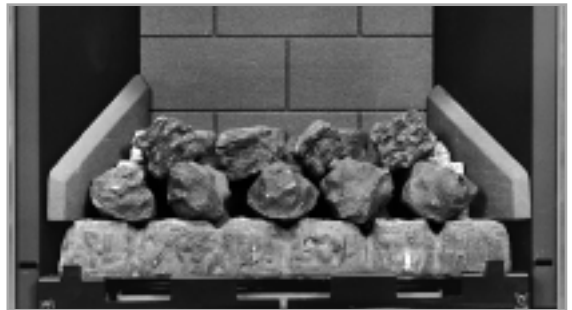

Place the top row of five coals onto the flats in the matrix. Ensure the coals are not put into holes in the matrix. Bridge the gaps between the rear of the matrix and the centre row of coals. Rotational orientation may be desired.



Note: The coals must not be crammed together, or inserted into the holes in the matrix. A well laid out, generously spaced coal layout will give the best results.

The edges or corners of the front row of coals **MUST NOT** be allowed to enter the flame slots in the matrix. If in doubt, pull them forward as far as possible.

Fit the glass door assembly by locating the two lugs at its base in the fire surround, rotate the door upwards and secure in position with the two hand screws provided.



Pay special attention to finally adjust the coals with the fire lit on the HIGH setting in order to ensure that no flames play onto the firebox sides or the glass door.

9.0 FUEL BED LAYOUT (continued)

This will reduce the possibility of heat discoloration. If the coals need adjustment to give a good flame picture allow the fire to cool, remove the glass door, rearrange to coals slightly, refit the door and check again. It takes approximately 15 minutes for the full effect to be achieved. The fire is designed to operate correctly with the coals supplied when assembled according to the instructions. Never add to the fourteen coals, or change them for a different type. Never throw rubbish or other matter onto the fire.

10.0 FITTING THE DECORATIVE FRAME AND HOOD

The appliance is supplied with a decorative frame and convector hood. A plastic protective coating may have been applied to the face of the frame assembly, which should be removed at this stage.

The frame attaches to the firebox as a three piece clip-on assembly. The side pieces of the clip on assembly should be pushed into position first, followed by the top bar, which should overlap the sides.

Place the firefront casting in front of the fire with the Ashpan door.

Fit the convector hood to the firebox by engaging the mounting hooks into the relevant slots on the firebox. The hood should be pressed in and downwards to secure into position.

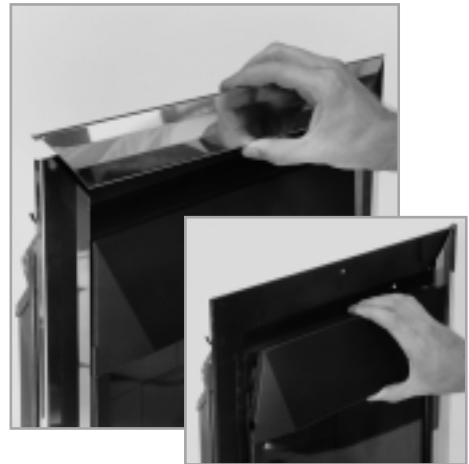

11.0 TESTING AND COMMISSIONING

Turn on and test the gas supply up to the fire for any leaks in accordance with current Approved Codes of Practice (ACOPs).

11.1 OPERATING THE APPLIANCE

The pilot is visible under the left hand side of the matrix. Rotate the coals for good viewing. Push in and turn the control knob to the SPARK position, and hold there for a few seconds.

Continue turning anti-clockwise through the spark click to the PILOT light position ensuring the pilot has lit. If not return the knob clockwise and repeat.

When the pilot lights after the spark keep the knob depressed for approximately ten seconds. Now release the knob and the pilot should stay alight. If the pilot is extinguished during use wait three minutes before repeating the ignition procedure.



To achieve the HIGH setting push the control knob in slightly and continue tuning anti-clockwise to the high position. The main burner should light after a few seconds. To decrease the setting to LOW turn the control knob clockwise to the low setting.

To turn to the PILOT position from the HIGH or LOW positions, press the control knob in and return to the pilot position and release. To turn the fire OFF keep the knob pressed in, return to the off position and release.

11.2 SPARK FAILURE

The gap between the spark electrode and the pilot should be 3.5 - 4.5mm to produce a good spark. There should be no need to adjust this. If under any circumstances the electric spark fails the pilot may be lit manually by proceeding with the ignition sequence as previously described and after turning the control knob through the spark position the knob should be held in and the pilot lit with a taper.

11.3 SETTING PRESSURE

Remove the screw from the pressure test point, which is situated on the main injector pipe and attach a U gauge. Light the fire on the HIGH setting.

The setting pressure should be in accordance with the figures stated on page 2 of these instructions. The fire is factory set to achieve these pressures and any significant variation could indicate a supply problem.

If the pressure is too high the gas supply meter may be set incorrectly. This should be checked with the fire running and if necessary reset by the gas supplier.

If the setting pressure is too low then check the meter governor pressure with the appliance running. If this is correct it will need to be reset by the gas supplier.

If the setting pressure is too low, but the meter pressure is acceptable, then a problem in the supply pipework is to be suspected. This will be dirt and debris, kinked or inadequate size pipes, restriction in a fitting or solder flashing across a joint.

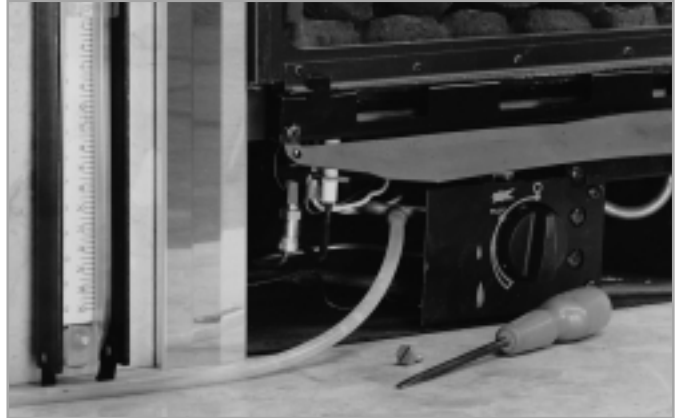

When the setting pressure is satisfactory, the gas side of the installation is complete.

Switch OFF the fire and refit the test point screw. Light the fire and check the test point for gas soundness.

12.0 FLUE SPILLAGE MONITORING SYSTEM

This fire is fitted with a flue spillage safety device (ODS). If the fire shuts down during use for no apparent reason then several things may be suspected. If a door or window has been opened creating a draught, then pilot disturbance is the problem and removal of the draught should resolve this. The gas pressure reaching the fire must also be checked (again, recall your installer to check and rectify any problem). The thermocouple connection into the back of the gas control valve may also have worked loose during installation, simply get the installer to tighten.

If pilot disturbance is not the cause, then the ODS safety system may be in operation. Switch the appliance OFF, check the flue and carry out any remedial work required. Relight the fire and carry out a spillage test. DO NOT allow the appliance to be used if it continues to fail a spillage test.

The aeration hole of the pilot must be carefully cleaned out on each annual service to ensure continued function of the ODS.

The spillage monitoring system shall not be adjusted, modified, or put out of operation by the installer. Any spare parts fitted MUST be of a type supplied for the purpose by the appliance manufacturer.

If the fire is not spilling, then further guidance should be sought, using the Troubleshooting section as a guide.

12.1 TESTING FOR SPILLAGE

Close all doors and windows to the room containing the appliance. Let the fire run on HIGH for five minutes. Take a smoke match, light it, and using a smoke match tube, hold it at the top edge of the fire opening, 15mm down and 5mm in. Starting 50mm in from either side, run the smoke match across the opening.



12.1 TESTING FOR SPILLAGE (continued)

All the smoke should be drawn away up the flue. Any smoke returning into the room indicates that spillage is occurring. If the initial spillage test fails, run the fire for a further 10 minutes and repeat the test. When the test has been completed satisfactorily, repeat with any extractor fans in the premises running on the highest setting and any communicating doors open. Finally, repeat with all doors open.

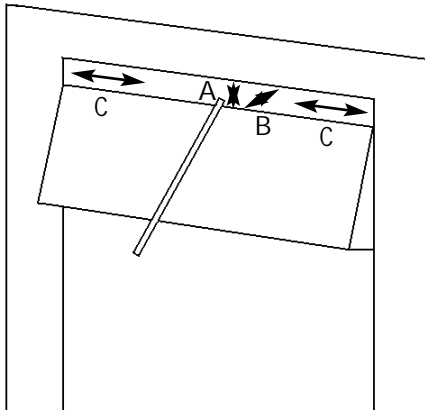

A. 15mm down from top of opening
B. 5mm in from front of opening
C. Disregard the outer 50mm either side of the opening

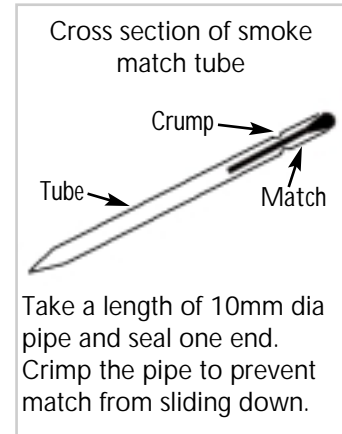

Do not allow the fire to be used until this test is satisfactorily passed.

13.0 FITTING THE FIREFRONT

Place the decorative firefront in front of the appliance and slide the ashpan door into place. The firefront shown within these instructions may be different to the one supplied with the appliance.

14.0 BRIEFING THE CUSTOMER

All instructions must be handed to the user for safekeeping. Show the customer how to light and control the fire.

After commissioning the appliance, the customer should be instructed on the safe use of the appliance and the need for regular servicing. Frequency of service depends on usage, but **MUST** be carried out at least once annually.

Advise that cleaning of the fire may be achieved when the fire is cold using a damp cloth and mild detergent on most surfaces.

Scratched and other superficial damage to the matt black paintwork of the appliance can be covered with matching heatproof spray. Use only the manufacturers' recommended spray paint. Paint only when the fire is **OFF** and cold. Always mask off the surrounding area to prevent contamination with overspray. Ventilate the room during the use of the spray. **DO NOT** attempt to spray paint the coals or ceramics, or wash them in water.

Advise that the fire will emit a "newness" smell for a time after initial commissioning and that extra ventilation may be needed during this time. Advise that the fire is fitted with a spillage safety device (ODS). If the fire shuts down, this system may be in operation. If spillage is suspected, **SWITCH APPLIANCE OFF** and call in the installer to investigate any problems.

Recommend that a guard be used for the protection of the young, the elderly and the infirm

15.0 SERVICING

Isolate the fire from the gas supply. Ensure that the fire is fully cold before attempting service. A suggested procedure for servicing is detailed below.

1. Lay out the dust sheet and tools.
2. Remove the convection hood.
3. Remove the glass door assembly (2 screws)
4. Carefully remove the ceramic components

15.0 SERVICING (continued)

5. Remove the cast front fret.
6. Remove the two screws that retain the data/control plate.
7. Disconnect the gas supply and remove the two securing screws in the tray legs.
8. Remove the burner tray.
9. Remove the convector box in reverse order of installation.
10. Check the fireplace opening for rubble accumulation and remove. If debris is excessive, initiate remedial work on the flue.
11. Check the flue with smoke pellet for correct operation.
12. Refit convector box using new seals where necessary.
13. Strip off the burner pipes and clean thoroughly
14. Clean out injector, pilot assembly and the burner tube. Do NOT remove the pilot injector.
15. Re-assemble and re-fit the burner tray.
16. Turn on the gas supply and leak test.
17. Refit the ceramics.
18. Refit the glass door assembly, ensuring a good seal.
19. Refit the convector hood.
20. Check any purpose provided ventilation is un-obstructed.
21. Light the fire and test for spillage.
22. Check setting pressure and safe operation of the appliance.

For specific servicing instructions, see the relevant sections.

15.1 CLEANING THE COALS

Remove the fire front casting and place to one side. Remove the convector hood. Remove the glass door assembly. Remove the ceramic components. Gently clean in the open air. Be careful not to create dust from the coals. Where necessary replace damaged components with genuine spares. Seal scrap ceramic components in plastic bags and dispose at proper refuse sites as directed.

Re-fit the coals by referring to the relevant section of these instructions. Refit the glass door assembly ensuring a good seal. Refit the convector hood.

15.2 DISMANTLING THE BURNER TRAY

Remove the tray as previously described. The pilot unit can be removed by undoing the tubing nut, the thermocouple nut on the rear of the valve, the two securing screws and lifting away. Remove the tubing nut from the valve end of the pilot pipe and blow through to dislodge any debris. Clean the exterior of the pilot assembly with a soft brush and blow through the flame ports on the pilot head. Check the aeration holes are free from lint or dirt. The pilot assembly is a non-serviceable item and should not be taken apart. The aeration hole must be absolutely clear internally for proper operation.

Remove the two tubing nuts on the ends of the gas pipe to the injector elbow. Release the screw through the supporting leg and lift assembly clear. The injector pipe can now be checked for debris. Remove the nut retaining the injector elbow. Blow through the elbow to remove any debris.

The valve is not field serviceable, apart from the pilot filter. Remove the control knob by pulling it forwards, then remove the largest of the three screws on the face of the valve. Slide the filter out and clean away any debris that may have accumulated. The filter element should also be blown clean. This component should not require replacement, however if signs of deterioration are evident then a genuine spare must be used. If a large amount of debris is present in the filter then the pipework and control should be thoroughly cleaned before re-assembly.

15.3 REMOVING THE CONVECTOR BOX

Remove the burner tray as described previously. Protect the hearth from potential damage.

Either unroll the coiled tensioner cables from the rear of the firebox, remove the securing nipples and tensioner adjusters, or unscrew the screws retaining the box to its mounting surface.

The fire box is now released from the opening and can be slid outward onto the hearth. Inspect the fireplace opening for debris and if excessive rectify the flue before proceeding further. Check the seal around the fireframe and if necessary replace. Refit the convector box as described in the fitting section of these instructions.

15.4 PILOT ASSEMBLY

Remove the burner tray as in relevant section and pilot unit as described.

Clean the pilot assembly with a soft brush and blow through. Check the aeration holes are free of any dirt or lint. Clean thoroughly internally, the connection can be removed from the base of the pilot unit using two spanners to make cleaning easier. Do not damage or try to remove the pilot injector.

The unit is factory set and the only check necessary is to ensure the spark gap is correct. See specifications for gas setting.

16.0 TROUBLESHOOTING GUIDE

Fire sparks but pilot does not light

No gas to fire. Check isolators are open.
Pipework blockage. Clean out.
Air not fully purged. Repurge supply or wait longer.
Spark earthing to metal work. Reset gap correctly.
Blocked pilot. Clean out internally.

Pilot lights but then goes out

Severe restriction in gas supply. Clear obstruction.
Faulty thermocouple. Replace pilot unit.
Hold control knob in for longer.
Check control knob does not foul data plate.
Missing grommets seal in firebox. Replace.

Fire does not spark at pilot

HT lead detached. Refit.
Spark gap too large or small. Reset correctly.
Faulty piezo unit. Replace.
Debris shorting out electrode. Clean.
Spark shorting to metalwork under tray. Realign HT lead.

Fire runs for a time and then cuts off

Excessive room draught or flue pull. Rectify.
Loose or faulty thermocouple. Rectify.
ODS system in operation.
Firebox grommet seal not fitted. Rectify.
Lint in pilot aeration hole. Clean thoroughly internally.

Pilot flame shrinks when fire is on high

Poor gas flow to fire. Check pressure with fire on high. If pressure is low remove any restriction in pipework or valve. Check all isolators are adequately sized and fully open. Check meter pressure is adequate.
Air leak under base of firebox. Rectify.
Lint in pilot aeration hole. Clean thoroughly internally.
Firebox grommet seal missing. Rectify.

Fire smells when first lit or in use

Newness smell from brand new appliance.
Spillage occurring. Carry out spillage test and rectify any problems.
Low temperature sealants or combustible materials used in incorrect location.
Air leak under base of firebox. Rectify.
Firebox grommet seal missing. Rectify.

USER INSTRUCTIONS

<i>Section</i>	<i>Contents</i>	<i>Page No.</i>
1.0	Important Notes	1
2.0	Firefront	2
3.0	Clearances to Combustibles	2
4.0	Ventilation	2
5.0	Operating Instructions	2
6.0	Flue Spillage Monitoring System	3
7.0	Cleaning	3
8.0	Coals and Ceramics	3
9.0	Servicing	3

1.0 IMPORTANT NOTES

The installation and Servicing of this fire **MUST** only be carried out by a competent person (such as a CORGI registered fitter) in accordance with the Gas Safety (Installation and Use) Regulations 1998, the relevant British Standards, Codes of Practice, the Building Regulations and the manufacturer's instructions.

Failure to comply with the above recommendations could lead to prosecution and invalidate the appliance warranty.

Please ensure you are handed all of the manufacturers documents on completion of the installation. This will include these instructions.

Always keep a note of the installer's name and address, the original purchase receipt and the date of installation for future reference.

The fire and flue should be serviced regularly to ensure continued safe operation. See the servicing section for further reference.

Parts of this appliance become naturally hot during use. It is recommended that a suitable fire guard conforming to BS 6778 or BS 6539 is used, especially where young children, the elderly or infirm are concerned.

Combustible items, such as flooring and furniture and soft wall coverings (such as blown vinyl or embossed paper) may discolour if fitted too close to the fire. See relevant section for further details on clearances to combustibles. No combustible materials or flooring should protrude onto the hearth.

DO NOT burn any foreign material on this fire, the coals must be of the correct type and laid out in accordance with the relevant section of these instructions. Failure to do so could create a hazard or lead to sooting.

Before the appliance is installed the chimney should be swept. All flues should be checked by the installer to ensure there are no defects or obstructions that may prevent the flow of combustion products.

This appliance is fitted with a flue blockage safety device which will shut down the fire if abnormal flue conditions occur. It is **NOT** a substitute for an independently mounted CO detector.

This appliance is only for use with the gas type for which it is supplied.

2.0 FIREFRONT

This fire is supplied with a particular style of firefront. Use of the firefront will ensure an adequate air-flow under the firebed for the correct functioning of this appliance.

Compliance with safety standards cannot be guaranteed another style of front is used.

3.0 CLEARANCES TO COMBUSTIBLES

A combustible shelf may be fixed to the wall above the fire, providing that it complies with the dimensions given below.

<i>Maximum depth of shelf</i>	<i>Minimum distance from inside edge of fire to underside of shelf</i>
100mm (4in)	203mm (8in)
150mm (6in)	305mm (12in)
203mm (8in)	356mm (14in)

A non-combustible shelf may be fitted to within 10mm of the top edge of the fireframe.

Combustible materials, such as wood, may be fitted to within 100mm (4in) of either side of the frame of the appliance, providing the forward projection does not exceed 100mm (4in)

Any combustible side walls must be at least 500mm to the side of the radiant heat source.

As with all heating appliances, any decorations, soft furnishings and wall coverings (i.e. flock, blown vinyl and embossed paper) positioned too close to the appliance may discolour or scorch.

4.0 VENTILATION

No purpose provided ventilation is normally required for this appliance. The requirements of other appliances operating in the space or room and the results of a spillage test must be taken into consideration when assessing ventilation requirements, this will have been carried out by your CORGI registered installer.

For Republic of Ireland, ventilation may be required, see IS 813, ICP3, IS 327 and any other rules in force.

5.0 OPERATING INSTRUCTIONS

The pilot is visible through the underside of the left hand side of the matrix. Push in and turn the control knob to the SPARK position and hold there for a few seconds.

Continue turning anti-clockwise through the spark click to the PILOT light position, ensuring the pilot has lit. If not return the knob clockwise and repeat.



When the pilot lights after the spark keep the knob depressed for approximately ten seconds. Now release the knob and the pilot should stay alight. If the pilot is extinguished during use, wait three minutes before repeating the ignition procedure.

To achieve the HIGH setting, push the control knob in slightly and continue turning anti-clockwise to the high position. The main burner should light after a few seconds. To decrease the setting to LOW, turn the control knob clockwise to the low setting.

To turn to the PILOT position from the HIGH or LOW positions, press the control knob and return to the pilot position and release.

To turn the fire OFF, keep the knob pressed in, return to the off position and release.

6.0 FLUE SPILLAGE MONITORING SYSTEM

This fire is fitted with a flue spillage safety device (ODS). If the fire shuts down during use for no apparent reason then several reasons may be suspected. If a door or window has been opened creating a draught, then pilot disturbance could be the problem and removal of the draught should resolve this. The fire can then be re-lit in accordance with the previous section. A grommet seal may also be missing from the firebox causing abnormal draught to shut down the pilot. Call your installer to check seals are properly fitted.

If pilot disturbance is not the cause, then the ODS safety system may be in operation. Switch the appliance OFF, call in your installer to check the flue, ventilation and carry out any remedial work required.

DO NOT allow the appliance to be used until the flue system is passed as safe.

7.0 CLEANING

Before carrying out any of the following operations, ensure that the fire is OFF and completely cold.

Debris that may form on the firebed should be periodically removed by a competent person. Large deposits could indicate deterioration of the flue. This should be repaired by a competent person and the fire serviced before further use. To gain access to the firebed, remove the convection hood and glass door assembly. The hood should be lifted by approximately 10mm to disengage and remove the door by removing the 2 top screws, rotating away from the fire, disengaging the 2 lugs at the bottom and lifting away. The glass can be cleaned with a variety of glass or ceramic hob cleaners. Test on a small area first.

FIREFRONT - Any dust accumulating in the firefront may be removed using a vacuum cleaner or dry cloth. Heavy stains may be removed by using a damp cloth and mild household detergent. Brass parts of the firefront may be cleaned using a suitable brass cleaner. Replace the front centrally against the fire after cleaning.

PAINTED AREAS - These can be cleaned using a dry cloth.

8.0 COALS AND CERAMICS

See the relevant section in the Installation Guide of these instructions.

9.0 SERVICING

The fire and flue should be checked on an annual basis to ensure all of the product of combustion are entering the flue and that there is no excessive build up of soot. The frequency of service will depend on usage, but **MUST** be carried out at least once annually. Servicing must be carried out by a competent person, such as a CORGI registered installer.

Cleaning of the coals may be carried out by following the instructions given in the Installation section. The Installation instructions carry full servicing details for the use of the installer.

If debris from the flue or other foreign matter is found on the fire it may indicate a need for servicing. Do not use the fire until the source of the debris has been found and rectified.

Air vents (where fitted) should be checked periodically to ensure they are free from obstruction.

LIST OF SPARE PARTS

Items marked are available for the user to replace on the appliance.*

PART NO.	ITEM	PART NO.	ITEM
FT003820-0	Pack of 5 moulded coals*	FA004225/5	Hand screws (2)*
FT003825-0	Pack of 9 broken coals*	FB004225/5	Door glass*
FT003815-0	Ceramic combustion matrix*	FB004030/0	Ceramic side cheeks*
FT004135/5	Convector hood*	FT003710/5	Pilot assembly
FB004050/0	Ceramic brick panel*	FT003150/0	Gas valve
Enquire	Decorative frame*	FB004010/0	Burner tray
Enquire	Decorative fret*		