



# ATLANTA

## DECORATIVE RADIANT NATURAL VENT GAS FIRE

### User Instructions

These instructions should be read by the user before operating the appliance and retained for future reference

Model no. FAVR\*\*MN is only for use on Natural Gas (G20) at a supply pressure of 20 mbar in G.B. & I.E.

\*\* denotes trim & fret variant

# INSTALLATION INFORMATION

## CONDITIONS OF INSTALLATION

It is the law that all gas appliances are installed only by a competent (e.g. CORGI Registered) Installer, in accordance with the installation instructions and the Gas Safety (Installation and Use) Regulations 1998 as amended. Failure to install appliances correctly could lead to prosecution. It is in your own interest and that of safety to comply with the law.

The fire may be fitted below a combustible shelf provided that the shelf is at least 200mm above the top of the appliance and the depth of the shelf does not exceed 150mm.

The fire may be installed below combustible shelves which exceed 150mm deep providing that the clearance above the fire is increased by 15mm for each 25mm of additional overhang in excess of 150mm.

If this appliance is fitted directly on to a wall without the use of a fireplace or surround, soft wall coverings such as wallpaper, blown vinyl etc. could be affected by the heat and may discolour or scorch. This should be considered when installing or decorating.

The Model number of this appliance is FAVR\*\*MN and it is manufactured by:-

\*\* denotes trim & fret variant

BFM Europe Limited  
Trentham Lakes  
Stoke-on-Trent  
Staffordshire  
ST4 4TJ

Telephone 01782 339000

## **ABOUT YOUR NEW ATLANTA FIRE**

The Flavel Atlanta vented gas fire incorporates a unique and highly effective fuel bed, which gives a modern and stylish flame appearance. The fuel bed is produced from a ceramic fibre shaped to increase radiant heat and efficiency.

When first using the new fire a slight smell may be noticed. This is due to small deposits of oil on the firebox, but will soon disappear. Any odour can be quickly reduced by operating the fire on full for a few hours to allow the heat to fully penetrate all components.

Please take the time to fully read these instructions as you will then be able to obtain the most effective and safe operation of your fire.

**DO NOT UNDER ANY CIRCUMSTANCES ATTEMPT TO USE THIS APPLIANCE IF THE GLASS PANEL IS BROKEN OR HAS BEEN REMOVED.**

## IMPORTANT SAFETY INFORMATION

### WARNING

This appliance has an extremely hot working surface and as with all heating appliances a fireguard should be used for the protection of children, the elderly and infirm. Fireguards should conform to BS 8423 : 2002 (Fireguards for use with gas heating appliances).

**Servicing should be carried out annually by a competent person such as a CORGI registered engineer. It is a condition of Flavel guarantees that this is carried out by a competent person i.e a CORGI registered Engineer in accordance with these servicing notes**

We recommend that during the annual service, replacement of the pilot is carried out. **The pilot must be changed as a condition of the extended guarantee.**

The service should include visually checking the appliance and fireplace for accumulation of debris around the firebox.

The chimney should be checked regularly to ensure that all the products of combustion are entering the flue or canopy, as applicable, and that there is no excessive build up of soot.

Any purpose-provided ventilation should be checked regularly to ensure that it is free from obstruction.

**After any servicing work a gas tightness check and spillage test must always be carried out.**

Any debris or deposits should be removed from the fuel bed from time to time. This may be carried out by referring to the cleaning section as described later in this book.

Always keep furniture and combustible materials well clear of the fire and never dry clothing or items either on or near to the fire. Never use aerosols or flammable cleaning products near to the fire when it is in use.

**The fire remains hot for a considerable period after use and sufficient time should be allowed for the fire to cool before cleaning etc.**

The fire must only be operated with the contemporary trim & ashpan cover in position.

## OPERATING THE FIRE

The controls are located behind the ashpan cover below the fender. The controls, comprise a control valve to adjust the gas flow and a push button piezo igniter. To light the fire proceed as follows:-

- 1) Depress the control knob and turn anti-clockwise to the position marked pilot. Hold in the control knob for a few seconds to allow the gas to reach the pilot.
- 2) Continue to hold-in the control knob and press the igniter button. If the pilot does not light, continue to press the igniter button until ignition occurs. The pilot flame can be seen by looking across the front line of the burner. When the pilot has lit, continue to hold the control knob in for 5-10 seconds to allow the thermocouple to heat up, if the pilot goes out when the control knob is released, repeat the lighting sequence.

In the unlikely event of a failure of the igniter, the fire can be lit as follows.

Remove the Ashpan cover, Trim and Pilot Heat Shield, which is held in place with two screws. Depress the control knob and turn anti-clockwise to the position marked pilot. Hold in the control knob for a few seconds to allow the gas to reach the pilot. Insert the tip of a lit taper close to the tip of the pilot. This will light the pilot flame. When the pilot has lit, continue to hold the control knob in for 5-10 seconds to allow the thermocouple to heat up, if the pilot goes out when the control knob is released, repeat the lighting sequence. Once the pilot is lit replace the Pilot Heat Shield, Trim and Ash pan cover

**DO NOT UNDER ANY CIRCUMSTANCES ATTEMPT TO USE THIS APPLIANCE IF THE GLASS PANEL IS BROKEN OR HAS BEEN REMOVED.**

- 3) After lighting, turn the control knob in the anti-clockwise direction to the high position and the main burner will light. To gain the most efficient performance, it is recommended that the control is left in the high position for 5 to 10 minutes
- 4) The gas control can be turned clockwise from the maximum position to give the desired heat output.
- 5) To turn the fire off push in and turn the control valve fully clockwise in to the off position. The burner and pilot will go out.

### **WARNING**

**If the fire goes out for any reason or is turned off and it is necessary to re-light the fire it is important to allow the fire to cool for a full 5 minutes before attempting to re-light it.**

**NOTE : THIS APPLIANCE IS DESIGNED TO WORK SAFELY AND EFFECTIVELY DURING ADVERSE WEATHER CONDITIONS OR DOWNDRAUGHTS. HOWEVER, DURING SUCH TIMES FLAME DISTURBANCE MAY BE NOTICED. THIS IS NORMAL AND DOES NOT EFFECT OR IMPAIR THE SAFETY OF THE APPLIANCE.**

## CLEANING

### WARNING

Before attempting any cleaning operation ensure that the fire has been allowed to fully cool.

### CLEANING THE STAINLESS AND PAINTED METAL PARTS.

The trim fitted to this appliance is stainless steel, and must only be cleaned with a clean, damp cloth. Black painted metal parts should be gently cleaned with a damp cloth.

**Abrasive cleaners, chemical cleaning agents or any type of polish must never be used as damage to the paint may result.**

### CLEANING THE GLASS PANEL

To clean the glass panel, first ensure that the fire is cool, **please note that the glass panel will remain hot for a considerable period when the fire has been switched off.**

To remove the glass panel, follow the instructions overpage for removal and re-fitting.

The glass panel should be cleaned gently with a soft damp cloth and glass cleaner.

**DO NOT UNDER ANY CIRCUMSTANCES ATTEMPT TO CLEAN THE GLASS PANEL WHEN THE APPLIANCE IS RUNNING.**

**FOLLOWING CLEANING OF THE GLASS PANEL, ALWAYS ENSURE THAT THE ALLEN KEY IS REMOVED FROM THE ALLEN BOLTS AND REPLACED INTO ITS LOCATION AT THE BOTTOM RIGHT HAND SIDE OF THE FIREBOX.**

## REMOVING & REFITTING OF THE GLASS FRAME

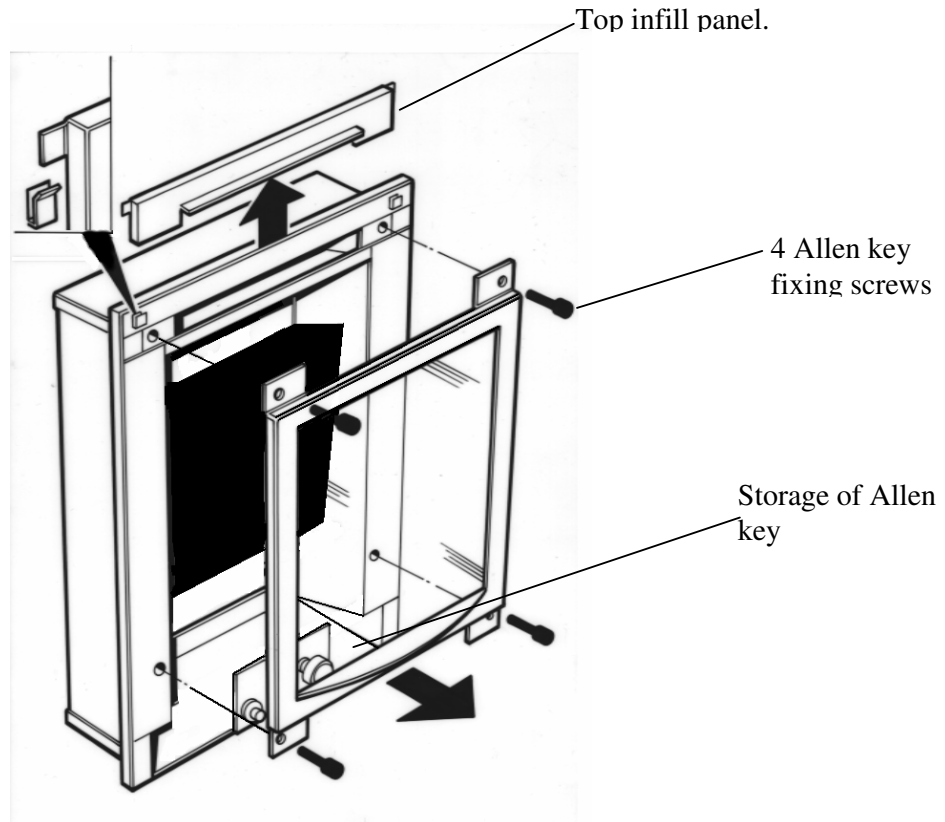

- a) Remove the contemporary trim & ashpan cover from the firebox.
- b) Remove the pilot heat shield, which is held in place at each end by 1 screw.
- c) Remove the top infill panel by sliding it upward out of the clips.
- d) Obtain the Allen key which is located at the bottom right hand side of the firebox.
- e) Loosen each Allen bolt a small amount at a time to prevent damage to the glass panel. When all the Allen bolts have been removed, lift away the glass frame and clean as per the previous page.
- f) Refit the glass panel to the firebox, again tightening each bolt a small amount at a time to prevent stressing the glass panel. Carefully tighten all the bolts to ensure good compression on the glass panel seal.
- g) Refit the contemporary trim & ashpan to the firebox.

**FOLLOWING USE OF THE ALLEN KEY, ALWAYS REMOVE IT FROM THE FIRE AND REPLACE IT INTO ITS LOCATION IN THE CLIP AT THE BOTTOM RIGHT HAND SIDE OF THE FIREBOX.**

## **USER REPLACEABLE PARTS**

**There are no user replacement parts.**

Replacement of any parts must be carried out by a competent person such as a CORGI registered gas installer.

Note. The rating plate is positioned at the bottom right hand side of the firebox.

**Due to our policy of continual improvement and development the exact accuracy of descriptions and illustrations cannot be guaranteed**

**Part No. B-109060  
Issue 1**



**BFM Europe Ltd.**  
Trentham Lakes  
Stoke-on-Trent  
Staffordshire  
ST4 4TJ

[www.bfm-europe.com](http://www.bfm-europe.com)

Telephone 01782 339000

Telephone (Service) (08700) 101187