

eco hometec

solar technical manual



eco hometec
Unit 11E
Carcroft Enterprise Park
Carcroft
Doncaster
DN6 8DD
Tel. 01302 722266
Fax. 01302 728634

e.mail: sales@eco-hometec.co.uk

<http://www.eco-hometec.co.uk>

C:\Users\tim.bartlett\Documents\Marketing Backup\Manuals Various\Solar Manuals\Old Solar Manuals Do Not Use\Solar_Technical_Manual_Nov_2008.doc\18 November 2008

eco hometec has a policy of continuous improvement and reserves the right to change any specification without notice. Your statutory rights are not affected.

eco hometec is committed to design, develop and produce environmentally friendly appliances for both domestic and commercial applications

1.	Why choose eco hometec	4		
2.	What is Solar Panel Technology?	5		
3.	Why Invest in Solar Panel Technology?	5		
4.	Types of Solar Panels?	6		
	1.1 Flat plate panel	6		
5.	Evacuated (or vacuum) tube panel	7		
6.	Solar Panel Feasibility - is it suitable for my property?	7		
7.	Positioning the collectors:	8		
	1.2 Inclination of solar panels	8		
8.	Planning Permission	8		
	1.3 Permitted development rights	9		
9.	Locations & Climate – will it work in the UK?	9		
10.	Solar Panels for Hot Water	11		
11.	Solar Panels for Central Heating	12		
12.	Figure 10 Solar Panels for Central Heating	13		
13.	Solar Panels for Central Heating	13		
	1.4 Can it heat my building(s)	13		
	1.5 Solar space heating system design	14		
14.	Solar Panel Hot Water Heat Transfer System and Solar Controller	15		
15.	Water/glycol mix Heat Transfer Fluid	16		
16.	eco hometec solar water heating Pump and Control Set	16		
1.	To collector	16		
17.	Solar Panels for Swimming Pools	20		
18.	Solar Compatible Combi Boiler	21		
25.	Flat plate solar collector design & construction	23		
	1.6 Our collectors consist of:	23		
26.	Vacuum tube solar collector KSR10	24		
27.	Flat plate panels or vacuum tubes?	25		
28.	The aesthetics of tubes and panels.	26		
29.	Flat plate panels or vacuum tubes? The conclusion.	26		
30.	Are there any grants for this type of stuff?	27		
	Figure 1 eco hometec flat plate solar panel	6		
	Figure 2 eco hometec vacuum solar collector	7		
	Figure 3 inclination of the solar collector plane	8		
	Figure 4 Ground mounted on 'A' frame.	8		
	Figure 5 Monthly distribution of annual solar radiation received on a plane inclined at 30° facing South in the South of England.	10		
	Figure 6 kWh/m ² per year	10		
	Figure 7 Solar system components groups	11		
	Figure 8 Typical domestic twin coil solar hot water installation with boiler back up	12		
	Figure 9 Solar system components groups	12		
	12. Figure 10 Solar Panels for Central Heating	13		
	Figure 11 Solar system components groups	15		
	Figure 12 Metalflex Solar Pipe	15		
	Figure 13 Solar pumping station	16		
	Figure 14 EC25 Solar Compatible Condensing Boiler	21		
	Figure 15 EC25 'S' Type Combi Hydraulic system design when installed with solar heating	22		
	Figure 16 Vacuum tube solar collector	24		
	Figure 17 Vacuum tube solar collector 2KSR10 (the battery)	25		
	Figure 18 Tube seal failure	26		
	Figure 19 Typical Solar Installation	27		

1. Why choose eco hometec



Compact space-saving design



High quality manufacture



Supplied as a complete kit of parts for quick and simple installation



Virtually maintenance-free



Unobtrusive roof-integrated solar collector



Simple and safe feature against overheating and freezing



High performance



Low cost



Tried and tested in thousands of installations



Domestic water heating



Industrial water heating



Hot water for hotels, schools, offices, shops, canteens etc.



Swimming pools



Caravans, boats, holiday parks



Greenhouses



Fish farms



Car washes



Heat exchangers



Agricultural and industrial processing

2. What is Solar Panel Technology?

Solar energy is the light and radiant heat from the Sun that influences Earth's climate and weather and sustains life. Since the early years, solar energy has been harnessed for human use through a range of different technologies.

Solar radiation and secondary solar sources, wind, wave power, hydroelectricity and biomass, account for most of the available renewable energy on Earth.

A solar thermal collector (solar panel) is specifically intended to absorb sunlight and collect heat.

Solar radiation is absorbed by the solar panel which in turn heats a water/glycol mix that is pumped through it. This heated water/glycol mix is circulated through a separate coil in the hot water cylinder and used to heat domestic tap water. As well as heating domestic tap water the same solar array can be used for central heating and swimming pools.

Depending on the location and size of the solar array installed, the annual space heating contribution can range from 10% to 60% or more in a modern ultra-low energy type buildings; even up to up to 100% where a large seasonal thermal store is used.

3. Why Invest in Solar Panel Technology?

Installing solar panels saves energy which saves money.

Installing solar panels reduces CO₂ emissions which saves the environment.

'Greening the home' can be achieved through a series of steps, including double glazing and adding a condensing boiler.

However, solar panels and solar hot water heating are considered as "the ultimate way to achieve a large reduction in carbon emissions".

eco hometec believe that the UK should follow the Spanish model of installing solar hot water heating and solar thermal technology in all newly built houses. Spain has adopted a blanket policy, which stipulates that all new homes should include solar hot water heating solutions.

House builders and developers are under increasing pressure to improve the energy efficiency of their homes, with ambitious government targets to make all homes zero carbon by 2016. However, the UK is currently lagging behind Europe when it comes to building energy efficient homes.

Solar thermal technology and solar hot water heating can complement an existing heating and hot water system by providing up to 70% of a house's hot water requirements.

Solar water heating can provide almost all of your hot water during the summer months about 70% annually. The average domestic system reduces CO₂ by around 350 - 400kg per year, depending on the fuel replaced.

4. Types of Solar Panels?

1.1 Flat plate panel

The most common type of solar thermal collector is described as a flat plate panel. A weatherproofed, insulated box containing a black metal absorber sheet with built in pipes is placed in the path of sunlight. Solar energy heats up a water/glycol mix in the pipes and this is then pumped through the system. The eco hometec solar panel consists of:

1. A transparent cover made of SUN PLUS glass panes with very high transmittance (about 92%) of short-wave light spectrum.
2. An absorber - a copper plate coated with a black chrome selective surface with properties

of high-absorption, about 95%, and low-emissivity of solar heat.

3. Our collectors are coated with a black chrome selective surface to absorb solar radiation. As this process is electrolysis and does not involve any coatings the long term performance is not affected in any way from peeling or lifting.

4. eco hometec panels are constructed so that the copper absorber plate is welded to the copper heater pipes. As copper is a better conductor of heat than Aluminium, the all copper construction is the most efficient.

5. An aluminium frame and insulation are used to reduce the heat losses.

Figure 1 eco hometec flat plate solar panel

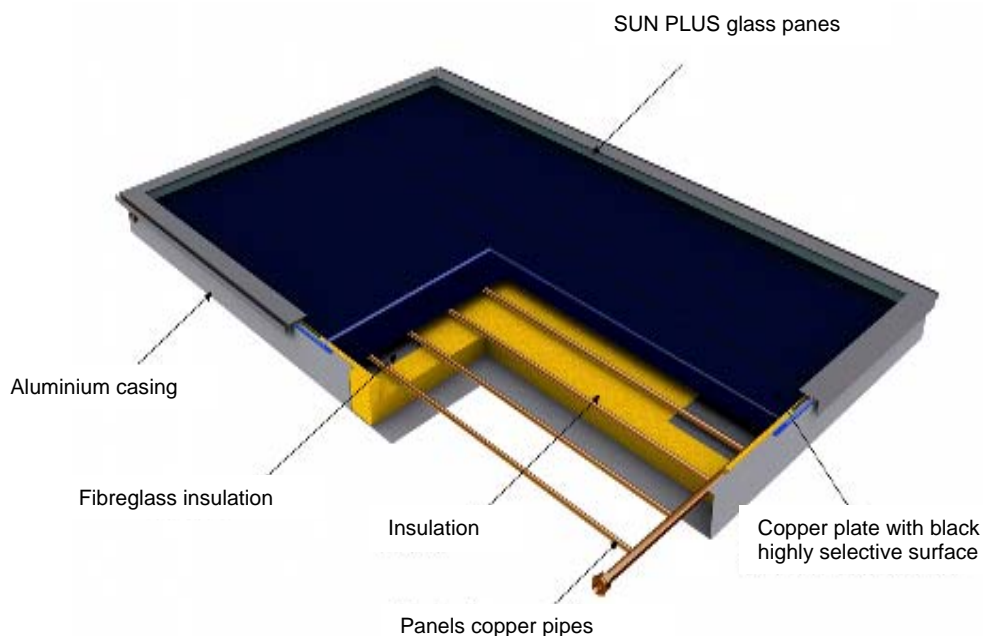

Height:	89,00 mm
Width:	1037,00 mm
Length:	2018,00 mm
Weight:	38,00 Kg

Case:	Painted - RAL7022
Absorber area:	1.83m ²
Gross surface:	2.09 m ²

5. Evacuated (or vacuum) tube panel

These collectors have multiple evacuated glass tubes which heat up solar absorbers and the water/glycol mix circulating through them.

The vacuum within the evacuated tubes reduce conducted heat losses, allowing them to reach considerably higher temperatures than most flat-plate collectors. The evacuated tubes draw their energy from the available light rather than outside temperature.

For these reasons they can perform well in colder typically alpine conditions. The advantage is largely lost in warmer climates, except in those cases where very hot water is desirable, for example commercial process water.

The eco hometec vacuum solar collector consists of 10 vacuum tubes made of glass pipe with antireflective coating with absorbers inside.

Figure 2 eco hometec vacuum solar collector



6. Solar Panel Feasibility - is it suitable for my property?

If you are considering installing a solar hot water heating system there are a few important points to consider. Solar hot water heating systems use heat from the sun to work alongside your conventional water heater. The technology is well developed

with a large choice of equipment to suit many applications.

Both types of solar hot water heating, flat plate solar panels and solar evacuated tubes, work in the same way; radiated light is used to heat up a surface, usually selectively coated with a substance and in a way to collect light and convert it into heat efficiently. The selectively coated surface is called an absorber.

The absorber transfers heat to an array of pipes fixed inside the collector, which carries a non freezing heat exchange fluid. The heated fluid is then pumped to the hot water cylinder which in turn heats the contents.

For domestic solar hot water heating there are four main components.

- Solar panels or collectors - are fitted to your roof. They collect heat from the sun's radiation.
- A heat transfer system - uses the collected heat to heat water.
- Hot water cylinder - stores the hot water that is heated during the day and supplies it for use later.
- Solar differential pump and controller. Automatically controls the pump and system temperatures.

An dependent survey carried out on behalf of the Department of Trade and Industry surveyed 700 solar hot water heating systems installed in the UK. Among the conclusions were:

- Domestic solar hot water heating systems perform well in all parts of Britain although slightly better in southern areas compared with the north of England and Scotland.
- Systems using selective surface flat panels perform as well as those using evacuated tubes.
- Most systems perform as well now as they did when they were new.

Solar water heating can be used in the home or for larger applications, such as swimming pools. You will need 3-4 square metres of southeast to southwest facing roof receiving direct sunlight for the main part of the day for a domestic system. You may also need space to locate an additional water cylinder if required.

Choosing a system suitable to your needs requires consideration of a range of factors, including the area of south facing roof and the existing water heating system (e.g. some combi boilers aren't suitable).

7. Positioning the collectors:

Positioning the collectors is important for optimum performance. Collectors should ideally be mounted at an angle of between 30 degrees and 60 degrees on a south facing roof that is not shaded by overhanging trees, buildings or structures.

1.2 Inclination of solar panels

The inclination of the solar collector plane to horizontal plays an important role in the collection of solar radiation. The solar panels work best and are at their most efficient when the sun rays fall perpendicular to the collector's glass. Ideally the panels should sit at an angle of 30 to 40 degrees and face south. When this is impossible due to site constraints

then two arrays can be used on opposing west and east roofs.

Figure 3 inclination of the solar collector plane

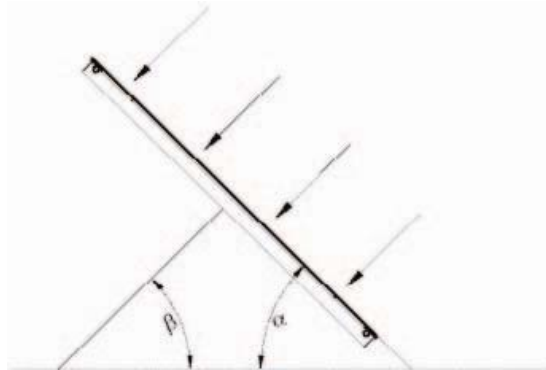

Good results can be obtained by splitting the collector array on East/West elevations but this should only be used when it is not possible to have a mainly southerly position for the collectors.

Collectors can also be wall mounted vertically however their performance will be less in the summer, when sun is highest and slightly better in winter when the sun is at its lowest.

If roof space is an issue they can be mounted on the ground or flat roofs on an 'A' frame.

Figure 4 Ground mounted on 'A' frame.



8. Planning Permission

In England, changes to permitted development rights for micro generation technologies introduced on 6th April 2008 have lifted the requirements for planning

permission for most solar hot water heating installations. Roof mounted and stand-alone solar hot water heating systems can now be installed in most dwellings, as long as they respect certain size criteria.

Exceptions apply for Listed Buildings, and buildings in Conservation Areas and World Heritage Sites.

In Wales, Scotland and Northern Ireland, the devolved governments are currently all considering changes to their legislation on permitted developments, to facilitate installations of micro generation technologies, including solar hot water heating.

Legislation is expected in all three countries later this year. Until then, householders in Wales, Scotland and Northern Ireland must consult with their local authority regarding planning permission.

1.3 Permitted development rights

The General Permitted Development Order (GPDO) grants rights to carry out certain limited forms of development on the home, without the need to apply for planning permission. The scope of the GPDO in England now extends to the following technologies:

Solar PV and solar thermal (roof mounted)
Permitted unless;

- The Panel's when installed protrude more than 200mm.
- They would be placed on the principal elevation facing onto or visible from the highway in buildings in Conservation Areas and World Heritage Sites.

Solar PV and solar thermal (stand alone)
Permitted unless:

- more than 4 metres in height,
- installed less than 5 metres away from any boundary.

- above a maximum area of array of 9m²
- situated within any part of the curtilage of the dwelling house or would be visible from the highway in Conservations Areas and World Heritage Sites.

9. Locations & Climate – will it work in the UK?

Solar energy availability in the UK is much greater than most people imagine. Indeed the UK receives on average approximately 65% of the annual radiation experienced by the South of Spain and even 55% of that received on the Equator. The solar energy that we experience is accounted for by approximately 40% direct radiation (received when it is sunny) and some 60% diffuse, or scattered, radiation (received on cloudy days).

The solar radiation received on a plane, facing due south, which is inclined at 30^o (this is a typical inclination for solar collectors situated on a pitched roof in the UK, varies from about 900 kWh/m² per year in the North of the UK to approximately 1,300 kWh/m² per year in the South West.

Whilst the highest amounts of monthly solar radiation are obviously experienced in the summer months, there is enough radiation coming from the sun in spring, autumn and winter to make a very useful contribution to a household's energy needs.

A total of 1350 hours of sunshine per year are experienced on average in the UK according to the MET Office. Areas in the north of the UK have about 1250 hrs per year while in the south the sunshine could provide up to 1470 hrs per annum.

There are 8 months when the sun is out for more than 100 hrs per month. Four of these months the sun is out for well over 150 hrs per month. There are only two months in the year when the sunshine is less than 50 hrs per month.

Figure 5 Monthly distribution of annual solar radiation received on a plane inclined at 30° facing South in the South of England.

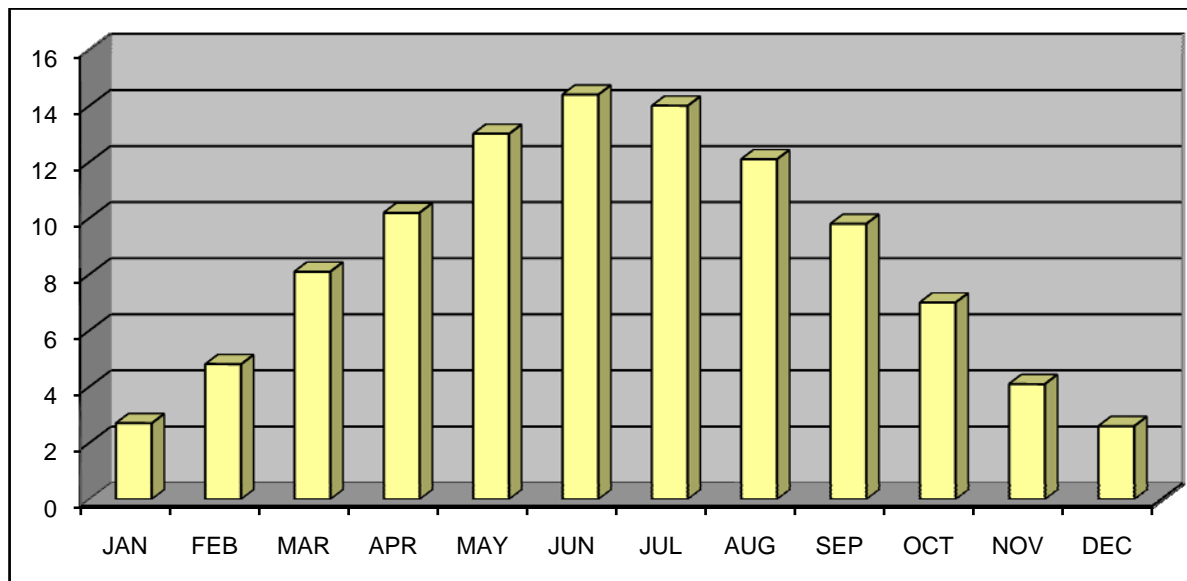

The contribution that a solar water heating system can make toward a household's energy requirements with a properly sized solar system can be expected to provide:

- 80 - 90% of all summer hot water needs
- 40 - 50% of spring and autumn requirements
- 10 - 15% of a household's winter water heating needs

Figure 6 kWh/m² per year

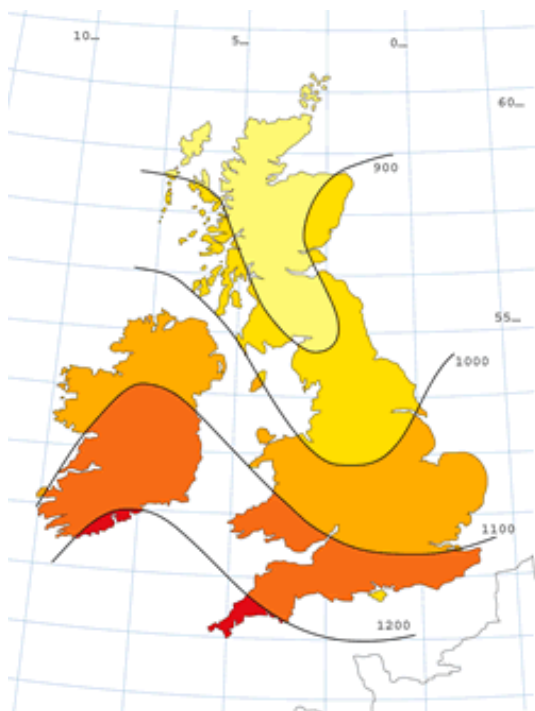

Solar water heating can provide almost all of your hot water during the summer months and about 50% year round. The average domestic system reduces CO₂ by around 350 - 400kg per year, depending on the fuel replaced.

10. Solar Panels for Hot Water

In all applications to heat hot water there are three main components groups 1, 2 and 3.

Figure 7 Solar system components groups

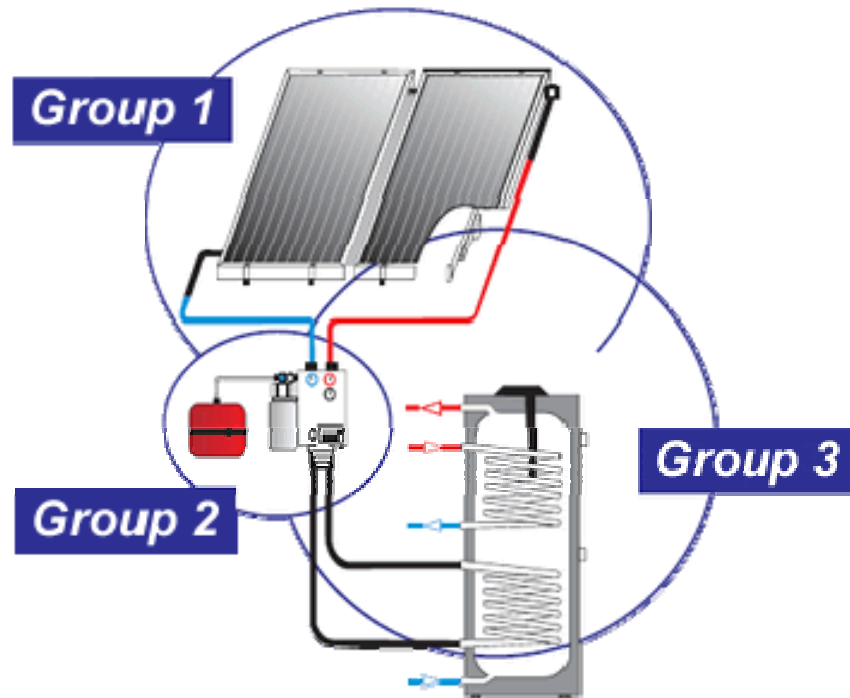

- **Group 1** - Solar collectors either flat plate panels or evacuated tubes - fitted to your roof or a ground mounted 'A' frame . They collect heat from the sun's radiation. There are 2 main types of collector:

Flat plate systems - which are comprised of an absorber plate with a transparent cover to collect the sun's heat, or

Evacuated tube systems - which are comprised of a row of glass tubes that each contain an absorber plate feeding into a manifold which transports the heated fluid.

- **Group 2**- A heat transfer system – a Glycol/water mix pumped through the collectors and pipes connected to a coil inside the hot water cylinder transfer the collected heat to heat water.
- **Group 3** - Hot water cylinder - stores the hot water that is heated during the day and supplies it for use later.

Figure 8 Typical domestic twin coil solar hot water installation with boiler back up

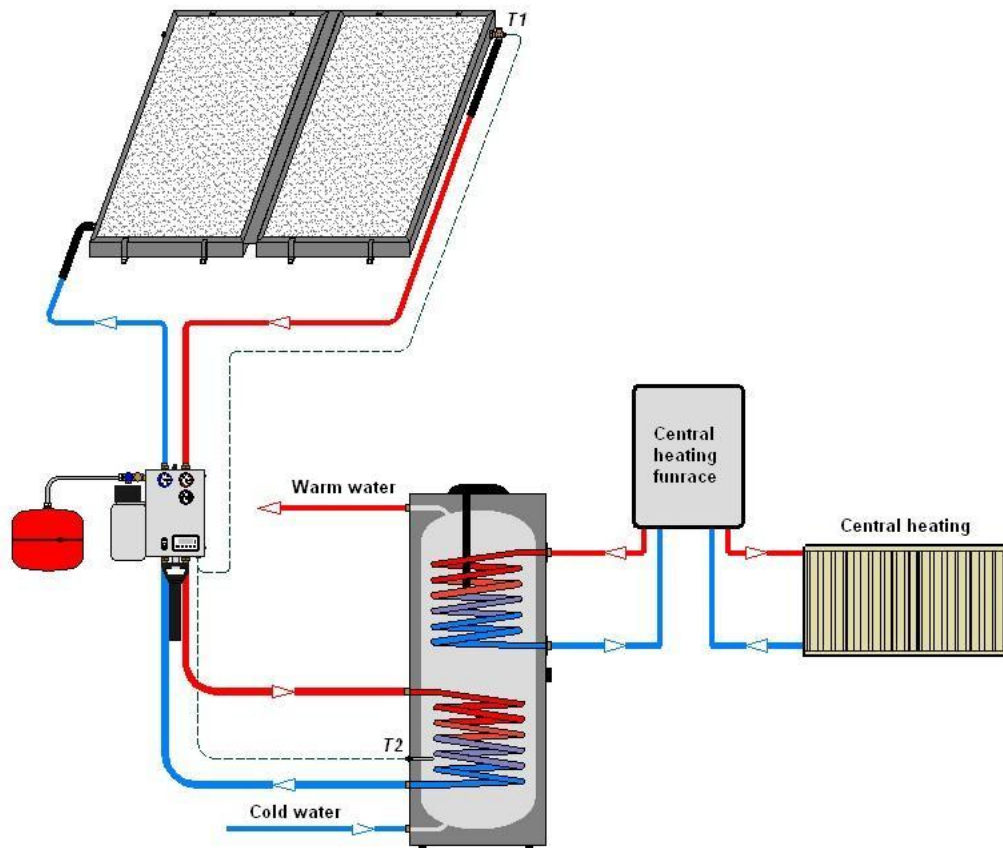

11. Solar Panels for Central Heating

In all applications to heat hot water and central heating there are three main components groups 1,2 and 3 plus additional equipment as shown in figure 10

Figure 9 Solar system components groups

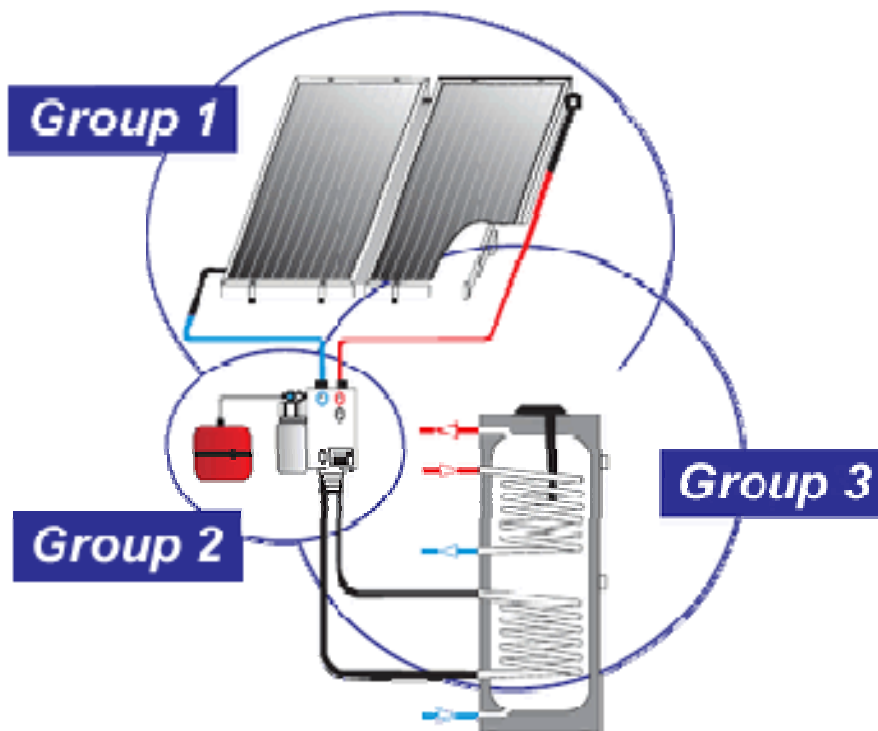

12. Figure 10 Solar Panels for Central Heating

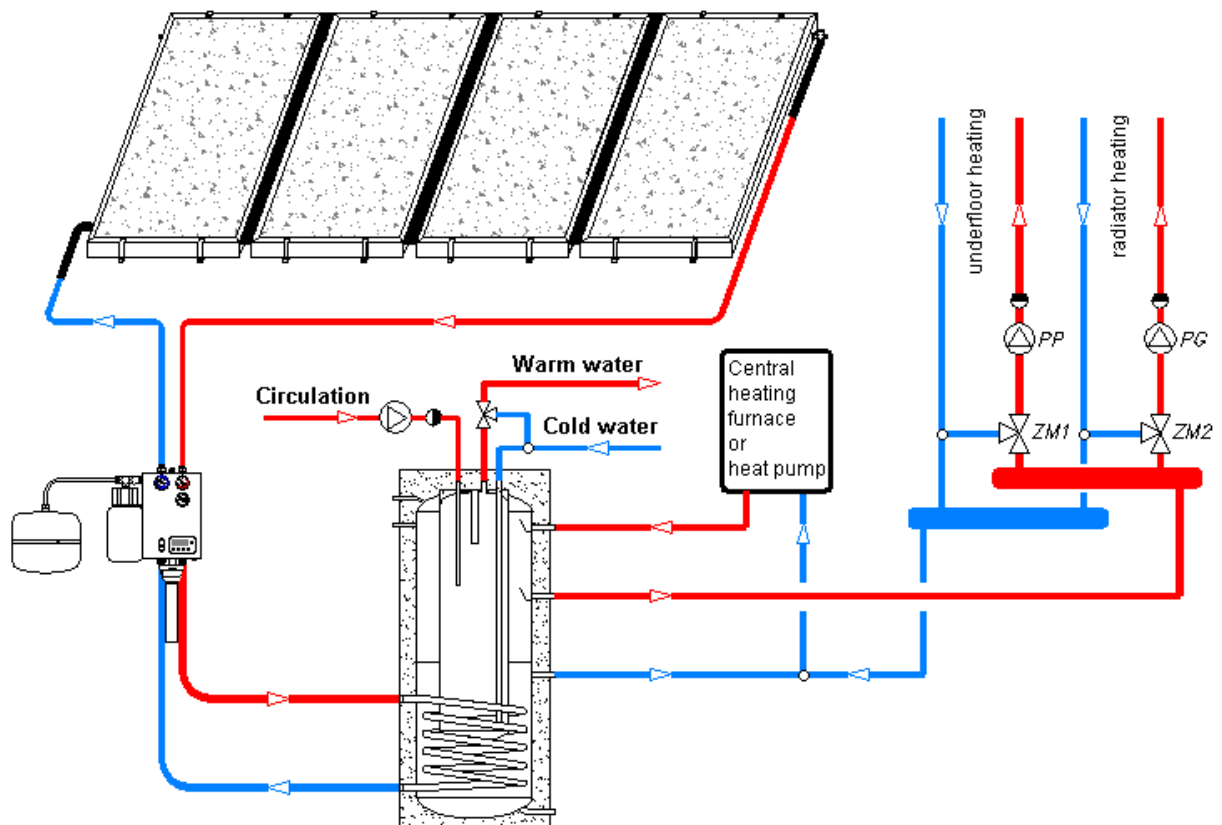

1.4 Can it heat my building(s)

13. Solar Panels for Central Heating

Solar collectors can be used for installations supporting building and space heating. However the following conditions should be considered:

Solar space heating is only suitable when installed as part of a new build in modern low energy or zero carbon construction and as such is unsuitable for existing buildings.

With the changes to building regulations and development of low-energy building techniques eco hometec are now able to design solar systems for domestic and commercial central heating.

As building heat losses reduce, the overall size and cost of the system is reduced. The lower water temperatures typical of solar heating make space heating possible when coupled with underfloor heating.

eco hometec offer solar heating systems that provide both space heating and hot water from a common array of solar thermal collectors. These need to be linked to an auxiliary non-solar heat source either a heat pump or condensing boiler.

eco hometec solar space heating systems range in size from individual properties to block heating schemes. Those serving larger groups of properties via district heating tend to be called central solar heating schemes.

eco hometec can design custom systems for your domestic or commercial project.

Depending on the location and size of the solar array installed, the annual space heating contribution can range from 10% to 60% or more in ultra-low energy modern buildings. The remaining heat requirement is supplied by one or more auxiliary sources, a heat pump or condensing boiler, in order to maintain the heat supply once

the solar heated water is exhausted. Such auxiliary heat sources may also use other renewable energy sources for example an air sourced heat pump.

During 2001, around 50% of all the domestic solar collectors installed in Austria, Switzerland, Denmark and Norway were to supply solar space heating systems, while in Sweden it was greater. In Germany, where the total collector area installed (900,000m²) was much larger than in the other countries, 25% was for solar space heating installations. Solar space heating systems have also been installed in Canada since the mid 1980s.

1.5 Solar space heating system design

The size and complexity of solar space heating systems, and the number of options available, mean that comparing design alternatives is not straightforward. Useful approximations of performance can be produced relatively easily, however accurate predictions remain difficult.

The amount of solar collector area needed to heat a new building depends on many factors. These include the available solar energy, collector efficiency, local climate, and heating requirements.

Heating requirements are based on insulation levels, the house's air tightness, and the lifestyle of the residents. Generally, the area of solar collector is about equal to 10% to 30% of the floor area of the house.

For more information on how eco hometec our products and services then contact us on 01302 722266 please post, fax (01302 728634) or email sales@eco-hometec.co.uk plans for quote.

14. Solar Panel Hot Water Heat Transfer System and Solar Controller

Group 2- A heat transfer system – the solar piping, water/glycol mix and the solar pumping station and controller connected to a coil inside the hot water cylinder transfer the collected heat to heat water.

Figure 11 Solar system components groups

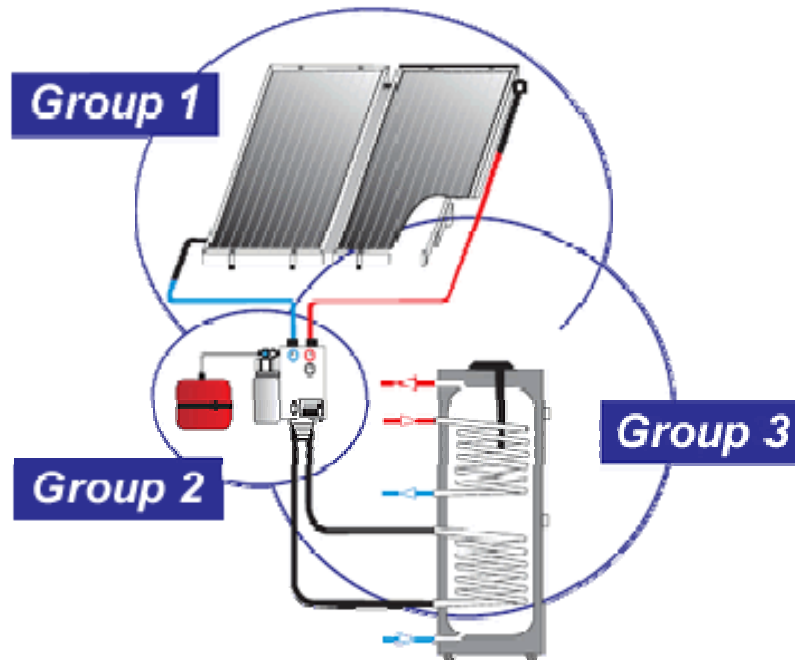

Heat transfer system – the solar piping between collectors and hot water cylinder

All pipework between collectors and hot water cylinder must be insulated. Due to the high temperatures (+150°C) associated with solar pipework then ordinary insulation is unsuitable. eco hometec recommend the use of our solar metalflex insulated flexible stainless steel pipe system.

The special advantage of the solar metalflex HT (high temperature) insulation material is it's UV resistance. Non UV resistant insulation will deteriorate over time and break down resulting in a loss of thermal efficiency.

eco hometec metalflex HT insulation, because of it's UV resistance can be installed outside without additional protective measures.

eco hometec metalflex HT insulation also

withstands a temperature range of -50°C to +150°C, making this product ideal for all solar installations.

Figure 12 Metalflex Solar Pipe



15. Water/glycol mix Heat Transfer Fluid

eco hometec Solaris biodegradable antifreeze fills the solar panels and piping. eco hometec Solaris has been especially formulated for use in solar panels. eco hometec Solaris is a propylene glycol, blended with corrosion inhibitors and distilled water.

All the constituents of Solaris are biodegradable.

The specialist inhibitors contained in Solaris are specifically formulated to withstand high temperatures and have been successfully tested to 300+°C for short periods – e.g. during stagnation. The inhibitors are formulated to protect those metals commonly found within solar panels, including copper, brass, stainless steel and aluminium. There is also an inhibitor that helps to prevent fine solids precipitating or coating heat exchanger surfaces - thus prolonging equipment life and thermal efficiency.

Solaris provides excellent frost protection, remaining as a fluid down to -20°C. Solaris is supplied premixed.

16. eco hometec solar water heating Pump and Control Set

The eco hometec solar water heating Pump and Control Set is designed for installations with both flat and vacuum tube solar collectors.

The microprocessor based multi-functional integrated unit providing complete control for the solar heating system. It operates based on temperature difference between solar collector and system return (from tank) temperatures.

The controller is designed for various applications and as such comes with 3 temperature sensors. For most applications e.g. hot water cylinder and collectors only two of the sensors are required.

The controller is factory programmed with six different control/sensor variations that make it suitable for controlling a variety of installations and can be configured to heat

additional items e.g. central heating systems and swimming pools.

The eco hometec solar water heating Pump and Control Set is designed for 230 ~ 240v 50Hz single phase operation and includes the following features and components:

- Heating carrier circulating pump
- Air separator and bleed valve
- Heating carrier flow meter
- Safety valve
- Check valve, cut-off valve, manometer
- Two thermometers for measuring the supply and return temperatures.
- Controller of pump operation with a set of sensors.
- All the elements of the subassembly are built in a cabinet case made of steel sheet lacquered in white.

Figure 13 Solar pumping station

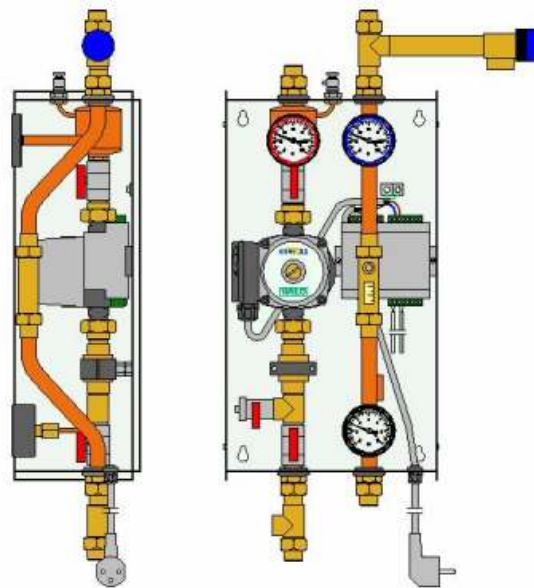

Group 3 - Hot water cylinder - stores the hot water that is heated during the day and supplies it for use later.



The eco hometec solar cylinder is a stainless steel unvented hot water cylinder which has a 25 year guarantee. Unvented cylinders are connected and supplied directly from the cold water mains supply, resulting in hot and cold water being delivered to all outlets within the dwelling at mains pressure, fast filling baths and power showers are a reality. Feed and expansion tanks associated with a conventional cylinder and tank installation are no longer required.

eco hometec unvented cylinders offer high performance water heating and hot water delivery flow rates of up to 55 litres per minute.

The very large surface area of the solar heating coil means that the maximum

heating advantage can be achieved from the solar system.

Unvented cylinders are now commonplace in the UK and are taking over from traditional gravity fed (vented) cylinders as the product of choice for many installers in both new build properties and retro-fit units in existing properties.

The eco hometec solar cylinder can be fitted as either a *bubble top (BT* with internal air gap expansion) or **fully flooded cylinder (FF** separate expansion vessel required). Fully flooded units offer a superior hot water performance when solar gain is low, whilst bubble top units offer space-saving solutions when the dedicated area for water storage is tight.

**As a general rule, eco hometec would recommend that Solarcyls are fitted using the fully flooded option as a greater amount of usable hot water from the upper heating coil is available.

The capacity of the cylinder on a solar installation must be based not just on the size of the cylinder but also on the amount of hot water required from the cylinder when the solar gain is very low.

It is generally recognised that fitting a larger capacity cylinder than would normally be the case in a conventional hot water system will, over the course of a year, increase the solar efficiency of the cylinder. A large cylinder that heats up fully during a day with high solar radiation, may well, dependent upon individual hot water demands, provide hot water well into the following day without alternative energy sources being deployed.

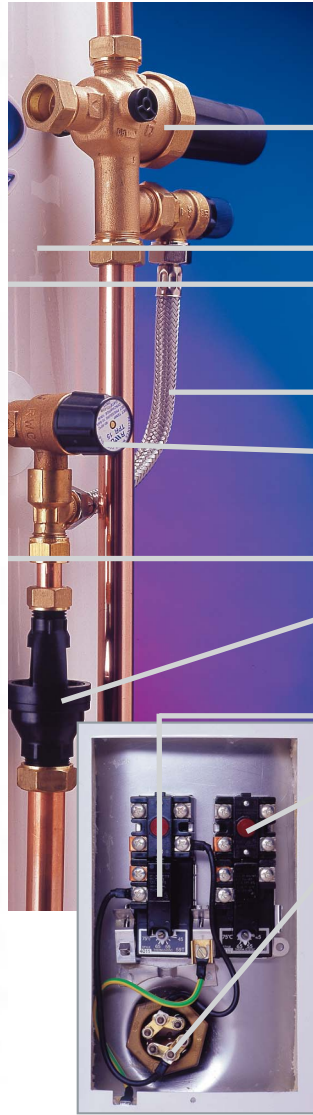

CYLINDER SPECIFICATION

- Hot water connection – 22mm compression fitting (removable dip tube)
- eco cylinders are designed to be installer friendly. “Multibloc” valve supplied loose for on-site installation. Comprises line strainer, 2.1 bar pressure reducing valve, balanced cold water port, non return valve, 8 bar expansion relief valve
- Casing – white epoxy coated steel
- Cylinder material – stainless steel F18MT 1.35mm thick
- Heating coil connections – 3/4" BSP female
- Solar sensor bosses and pockets supplied to accept 6mm sensor
- Flexible hose supplied to carry expansion relief discharge to tundish
- Temperature and pressure relief valve, factory fitted. 90°C, 10 bar
- Every cylinder factory pressure tested to 16 bar, maximum working pressure 8 bar
- Insulation – CFC free fire retardant PU foam, 40-50mm
- Tee-piece and tundish (22mm outlet) supplied

ELECTRICAL SPECIFICATION

- Thermostat – factory fitted, adjustable 40°C-70°C
- Thermal cut-out, operates at 85°C
- Immersion heater – 3kW single phase 240V
- All cylinders have one immersion at low level
- Solar Direct has second immersion above coil

SELECTION & SIZING GUIDE INCLUDING ORIENTATION

The capacity of the cylinder on a solar installation must be based not just on the size of the cylinder but also on the amount of hot water required from the cylinder when the solar gain is very low.

It is generally recognised that fitting a larger capacity cylinder than would normally be the case in a conventional hot water system will, over the course of a year, increase the solar efficiency of the cylinder. A large cylinder that heats up fully during a day with high solar radiation, may well, dependant upon individual hot water demands, provide hot water well into the following day without alternative energy sources being deployed. eco hometec unvented cylinders are supplied as bubble top units that do not require an expansion vessel. This system will save space in the installation area. *eco hometec cylinders are also adaptable for use with an expansion vessel that will increase the usable capacity of hot water by 20%. eco hometec would generally recommend this option with solar cylinders as it will substantially increase the hot water available from the upper coil and lead to much greater user comfort in the winter months.

Application	Twin Coil Bubble Top	*Twin Coil Fully Flooded	*Solar Direct Bubble Top	*Solar Direct Fully Flooded
1 bed 1 bath + shower	RI210TC	RI170TC	RI210SD	RI210SD
2 bed 1 bath + shower	RI250TC	RI210TC	RI2150SD	RI210SD
3 bed 1 bath + shower	RI330TC	RI210TC	Fully Flooded	RI2150SD
4 bed 1 bath + shower	RI330TC	RI250TC	Fully Flooded	RI2150SD
4 bed 1 bath + 2 showers	RI330TC	RI330TC	Fully Flooded	2xRI210SD
5 bed 1 bath + 2 showers	2xRI210TC	RI330TC	Fully Flooded	2xRI250SD

Product Code	Solar Coil Area m ²	Aux Coil Area m ² Element	Standing Energy Loss kWh/24h	Dedicated Solar Volume (Vs) ltr	Total Volume (Vt) Bubble Top ltr	Auxiliary Volume (Va) Bubble Top ltr	Auxiliary Recovery Bubble Top mins	*Total Volume (Vt) Fully Flooded ltr	*Auxiliary Volume (Va) Fully Flooded ltr	*Auxiliary Recovery Fully Flooded mins
20RI170TC	0.47	0.47	2.04	67				200	133	41
20RI210TC	0.92	0.47	2.45	97	210	113	35	250	153	47
20RI250TC	0.92	0.47	2.83	97	250	153	47	300	203	62
20RI330TC	0.92	0.72	3.14	117	330	213	46	380	263	56
20RI210SD	0.92	3kW	2.45	97	210	113	145	250	153	196
20RI250SD	0.92	3kW	2.83	97	250	153	196	300	203	260

SOLAR INDIRECT
Twin Coil Single Immersion Heater

SOLAR DIRECT
Single Coil Twin Immersion Heater

CUTAWAY
Twin Coil shown

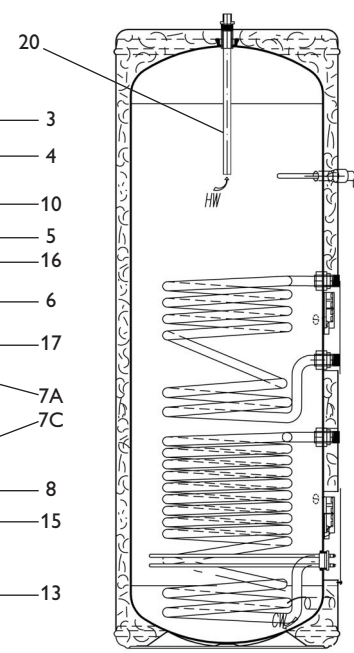
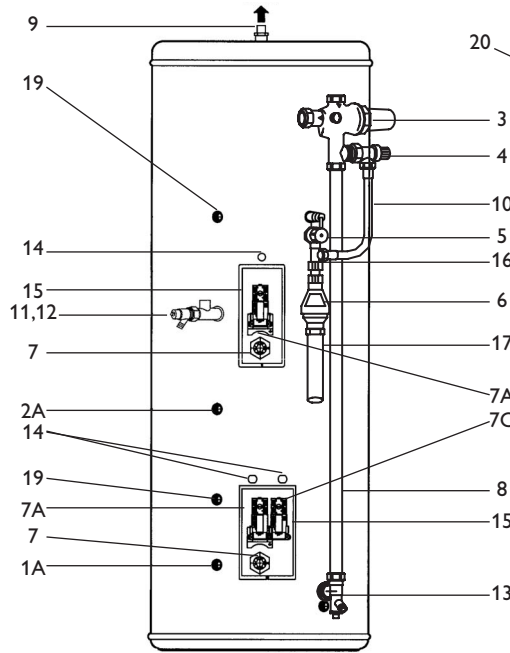
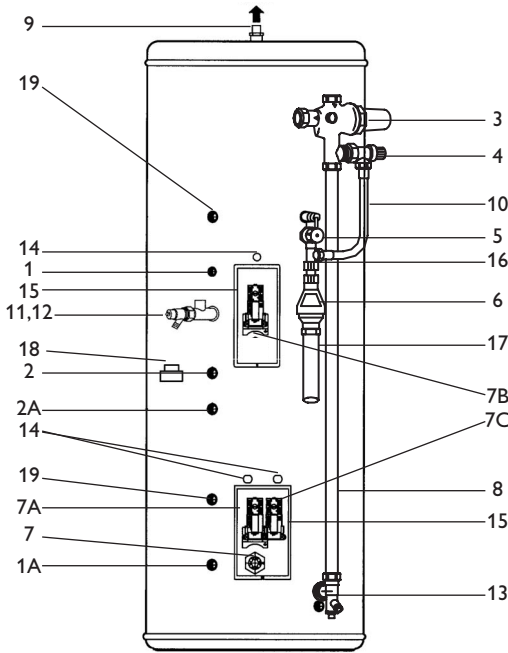

KEY	Part No	
1	Return 3/4" BSP Boiler	
1A	Return 3/4" BSP Solar	
2	Flow 3/4" BSP Boiler	
2A	Flow 3/4" BSP Solar	
3	Pressure Reducing Valve (Includes Item 4)	510511
4	Expansion Valve	510505
5	Temperature and Pressure Relief Valve	550853
6	Tundish	219002
7	Immersion Heater	71259
7A	Immersion Heater Thermostat	80020
7B	Thermostat Boiler	80030
7C	Thermostat Solar	80030
8	Cold Feed Tube	
9	Hot Water Outlet 22mm	

KEY	Part No	
10	Flexible Hose	202108
11	Secondary / Return 1/2" BSPF Fit 1/2" F x 1/2" M x 15mm Tee piece (Not supplied)	
12	Commissioning Valve / Fitting (1/2" MI Drain Cock)	250440
13	Elbow / Drain Cock	250445
14	Cable Entry	
15	Electrical Box	
16	Tee Piece	250006
17	Discharge Pipe (Not supplied)	
18	Motorised Valve (Not Factory Fitted)	92000
19	Solar sensor bosses	81019
20	Dip Pipe (removeable)	

Product order code	Capacity litres Bubble Top	Approx weight full kg (Bubble Top)	*Capacity litres Fully Flooded	*Approx weight full kg Fully Flooded	Lower immersion heater	Dimensions mm			Connection height from base					
						H	D	A	1	1A	2	2A	5	
Solar Direct														
20RI 210-SD	210	250	250	307	3kW	1400	580	70		225			545	1050
20RI 250-SD	250	292	300	359	3kW	1600	580	70		225			545	1222
Twin Coil														
20RI 170-TC			200	247	3kW	1150	580	70	725	225	490	390		895
20RI 210-TC	210	255	250	312	3kW	1400	580	70	950	225	745	545		1050
20RI 330-TC	250	297	300	364	3kW	1600	580	70	950	225	745	545		1222
20RI 330-TC	330	391	380	460	3kW	2090	580	70	1155	225	745	545		1697

eco hometec (uk) ltd.

Unit 11e, Carcroft Enterprise Park, Carcroft, Doncaster, DN6 8DD
Tel. 0044 1302 722266 Fax. 0044 1302 728634
www.eco-hometec.co.uk email:sales@eco-hometec.co.uk



17. Solar Panels for Swimming Pools

Solar thermal hot water heating is a cost effective way to heat swimming pools. Heating a swimming pool using traditional fossil fuel is expensive, creates harmful emissions of CO₂ and has environmental consequences.

eco hometec can design solar systems for domestic pool applications or large commercial projects.

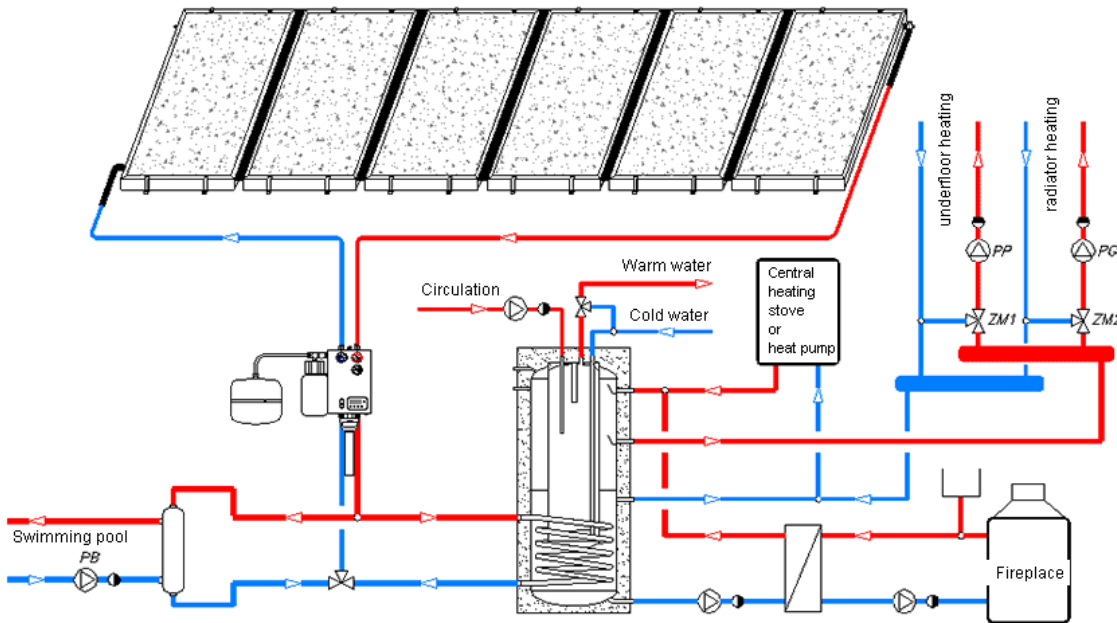

In the example above solar collectors are used for preheating household water, water in a swimming pool as well as supporting the building space heating system. In this solution, attention should be paid to the additional function of the buffer container making it possible to combine several heat sources.

The installation presented in the diagram is an example of the optimum use of a large array of solar collectors which in summer provide hot water, heat the swimming pool and support central heating during spring and autumn.

18. Solar Compatible Combi Boiler

The solar system can be used directly connected to an eco hometec Solar Compatible Combi or alternatively as part of conventional boiler and hot water cylinder system.

When connected to a solar Combi, solar heated, mains pressure hot water is supplied direct from the storage tank to the solar Combi.

Sensors located at the boiler inlet confirm the incoming water temperature and the boilers onboard VCO (Variable Controlled Output) system modulates the burner output so as just enough gas is used to raise the water temperature to the required set point, typically 55 – 60°C for domestic hot water.

During the summer months the storage tank water temperature maybe greater than the required set point so a blending valve, fixed before the solar Combi water connection, mixes cold mains water with water from the storage tank to the required set point.

When the inlet temperature is the same as the DHW temperature set point the VCO system prevents the burner from igniting.

Figure 14 EC25 Solar Compatible Condensing Boiler



FEATURE	BENEFIT	BENEFICIARY THE USER	BENEFICIARY THE ENVIRONMENT
Uses Solar Energy To Heat Hot Water	Less Fuel Is Used For The Production Of Hot Water	✓	✓
Uses Condensing & Solar Energy In One Compact Unit	Can ½ Fuel Bills And Save Up To 6 Tons Of CO ₂ Emissions	✓	✓
Pre-Heated Water Improves Combi Flow Rates	All The Benefits Of Combi + Fast Mains Pressure Hot Water	✓	✓

Figure 15 EC25 'S' Type Combi Hydraulic system design when installed with solar heating

Please call the eco hometec technical department for more advice on Solar heating installations.

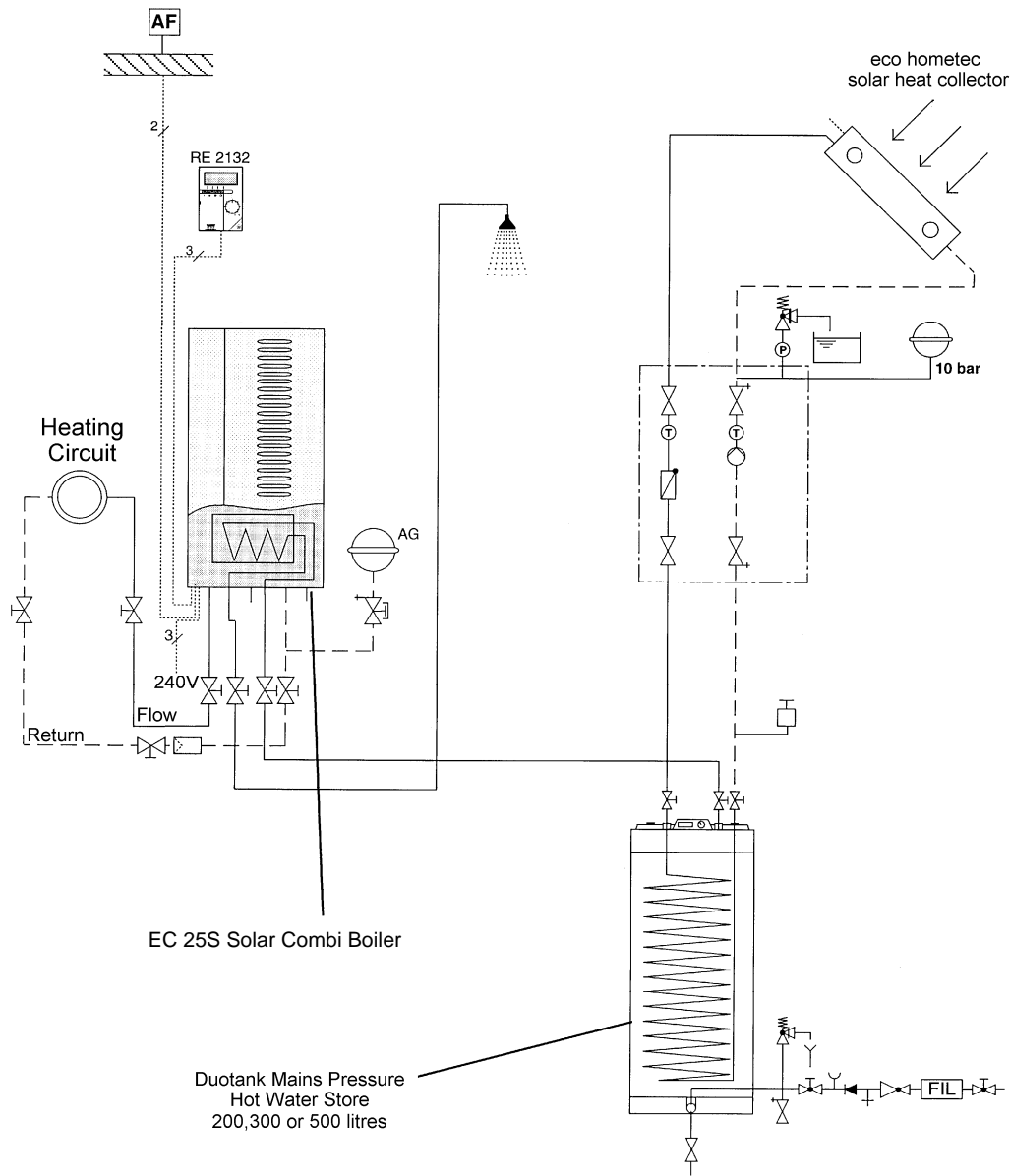

This system design delivers pre-heated, mains pressure water, to the combi. Stored water temperatures can rise to in excess of 80°C. In line blending valve mixes cold mains water with stored water to required domestic hot water set point. Water then passes through combi and boiler controls determine whether to fire the boiler and to what output. Combi used simply to top up stored water temperature to set point. System benefits include:

- 19. Faster flow rates of domestic hot water.
- 20. Minimal gas consumption for hot water production.
- 21. Constant hot water
- 22. Reduced emissions of greenhouse gases
- 23. Uses renewable energy and minimises use of fossil fuels
- 24. Simple controls - no need for end user interaction

25. Flat plate solar collector design & construction

Our company produces collectors with selective absorbent coating, characterized by high absorption of solar radiation and low heat emission.

In the case of flat plate panels the heat exchange fluid flows through pipes connected to the absorber plate.

eco hometec KS2000 panels are constructed so that the copper absorber plate is welded to the copper heater pipes.

As copper is a better conductor of heat than Aluminium, the all copper construction is preferred.

At eco hometec, we use a copper black chromed manufactured collector surface.

As this process is electrolysis and does not involve any coatings the long term performance is not affected in any way from peeling or lifting.

In our collectors we use SUN PLUS glass panes, which are among the best available.

They are distinguished by high transparency and low reflection of solar radiation.

All the materials used for construction of a collector are rigorously verified and quality controlled.

eco hometec thermal solar panels are high quality thermal solar water heating systems.

They are usually used for domestic water heating but also have industrial applications where hot water is required.

eco hometec systems are indirect, pressurised, and pumped.

They produce hot water without creating any carbon dioxide or any other greenhouse gas and create no pollution.

They produce energy without using scarce fossil fuels and are very cost effective. Its manufacturing company, Hewalex have manufactured solar collectors since 1992.

eco hometec solar water heating systems and Hewalex have around 150,000 collectors actively in use in Europe and other countries in the world.

Hewalex is an ISO 9001 company and its product are ISO certified.

This is the highest standard of certification for the United Kingdom and the whole European Community. Very few other systems have this standard.

Detailed test results are available on request.

A solar array can be installed with up to 8 collectors in a battery.

1.6 Our collectors consist of:

- A transparent cover made of iron-poor tempered glass with very high transmittance (about 92%) of short-wave light spectrum.
- An absorber - a copper plate coated with selective surface (having properties of high-absorption - about 95%) and low-emissivity of solar heat.
- An aluminium frame and insulation are needed to reduce the heat losses.

26. Vacuum tube solar collector KSR10

Vacuum tube solar collector KSR10 consists of items, which can be easily put together just before installation.

KSR10 collector consists of 10 vacuum tubes (made of glass pipe with antireflective coating) with absorbers inside; compact separator of heat medium; basic construction made of aluminium and connections made of stainless steel; top and bottom casings made of aluminium sheet, powder painted with RAL 7022.

eco hometec thermal solar vacuum tubes offer high quality thermal solar water heating systems. They are usually used for domestic water heating but also have industrial applications where hot water is required.

They can also be used for central heating as well as heating the water in swimming pools.

eco hometec systems are indirect, pressurised, and pumped.

Figure 16 Vacuum tube solar collector



Height:	111,00 mm
Width:	860,00 mm
Length:	2130,00 mm
Weight:	31,00 kg
Gross surface:	1,82 m ²
Absorber area:	0,93 m ²
Maximum work pressure:	6,00 bar
Absorber coverage:	TiNOX classic
Case:	Painted - RAL7022
Covering:	
Warranty:	5 years

Figure 17 Vacuum tube solar collector 2KSR10 (the battery)

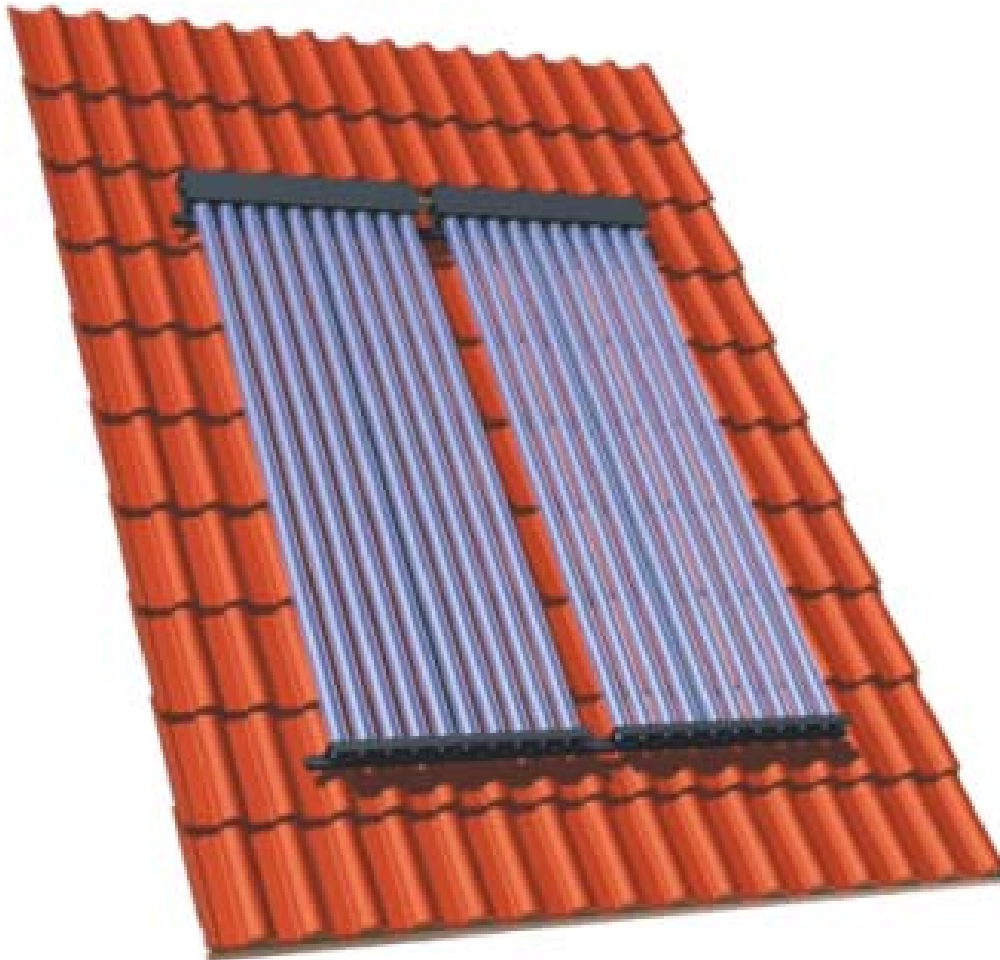

The solar array consists of two vacuum tube collectors KSR10 on a common basic construction. The battery can be enlarged up to 5 vacuum tube collectors joined in series.

27. Flat plate panels or vacuum tubes?

It is commonly believed that evacuated tube collectors have an efficiency advantage over flat plate collectors in the temperature range of 60 – 70°C normally required for domestic hot water. The advantage increases at higher temperatures and decreases below these temperatures.

Tubes perform slightly better in relation to their size; generally a vacuum installation needs around 10-12% less roof space than an equivalent flat plate system. If an individual tube fails it can be replaced; the whole manifold of tubes does not need replacement. There is a relatively much

higher failure rate of individual tubes (compared to the failure rate of well engineered individual panels). A tube failure can be diagnosed either when fogging is apparent or frost is not visible on a tube when it is visible on other tubes in the same manifold.

The stresses caused by the expansion and contraction of the glass in tube systems (the coefficient of expansion of glass and metal are not identical) can lead to stress where the glass is joined to the condenser and sometimes stress fractures are caused, which means that the vacuum fails.

The vacuum seal, located as it is in tubes where the glass tubing meets the manifold is actually located upon the hottest part of the collector. This causes stress upon the seal and in the examples you can clearly

see where the tubes have suffered from rain water ingress as a result of leaking vacuum seals.

Figure 18 Tube seal failure



Tubes are prone to over-heating because it is difficult to design tube systems in a way that avoids overheating. Some tube systems try to overcome heating issues by incorporating automatic valves in the manifold.

eco hometec flat plate panels have no vacuum seals and as such, although they get very hot, do not suffer from overheating damage.

Overheating reduces the life of the whole systems and therefore panel systems tend to last much longer than tube systems.

Well engineered solar panels, like the eco hometec solar panels are much more robust than tubes.

The system of holding the tubes in a manifold and securing the tubes to a roof means that in windy conditions minor tube movement can create glass fractures, which lead to vacuum failure. Panels do not suffer from this inconvenience.

In snowy conditions snow tends to remain in the gaps between the tubes, reducing efficiency, whereas it tends to slide off panels much sooner than it clears from tubes.

Panels can be roof integrated and are actually generally cheaper to install in new build situations. It is not possible to integrate tubes into the roof. Installations

with vacuum tubes usually require more service calls than installations with panels owing to the more fragile construction of tubes.

28. The aesthetics of tubes and panels.

Some people like an array of futuristic looking tubes on the roof whereas others prefer the flexibility that panels offer. Evacuated tubes can only be fitted to a metal frame which in turn is fixed onto the roof.

Panels can be fitted on roof or can be roof integrated. The effect of an in roof installation, makes them look better and they fit in better with architectural designs.

29. Flat plate panels or vacuum tubes? The conclusion.

To conclude, in Germany, where both types of solar systems have been used for over twenty years, the market originally favoured tubes and panels were considered as a second best choice. Today vacuum tubes comprise only 18% of the market, with flat plate panels taking a massive 82%. The end users found panels just as efficient, more aesthetically pleasing but also longer lasting with fewer faults and service calls required.

Finally a DTI solar test report stated that of eight systems tested all are capable of producing a useful amount of hot water under UK climate. When the load consists of a single 150 litre draw off early in the evening the extrapolated annual hot water production ranges from 3440 to 4820MJ. When the load is spread over the course of each day the corresponding range is 3620 to 4860MJ.

As expected expressing these results in terms of collector efficiency reveals that the two evacuated tube design operate at a higher efficiency than their flat plate counterparts. However they do not provide significantly more or less energy over the course of the year, and fall in the middle of the overall range of system outputs.

This implies that the relative sizes of the systems almost exactly compensate for differences in system performance. More surprising is the relatively small sensitivity to the pattern of water draw off over the course of the day. Conflicting factors which affect the outputs of the systems have been identified: a draw off pattern which requires water early in the morning requires that some hot water is stored overnight, with corresponding losses, but at the same time it gives lower tank temperatures during the day, allowing the collectors to operate more efficiently.

In all cases these two effects almost exactly cancel out, leading to slightly higher outputs for some systems and slightly lower for others when changing from a single evening draw off to one distributed throughout the day.

30. Are there any grants for this type of stuff

The BERR funded low carbon buildings programme provides grants to help with the costs of installing solar water heating technologies. To be eligible for a grant you will need to use a certified installer and products. All eco hometec solar equipment is certified and approved.

<http://www.lowcarbonbuildings.org.uk/home/>

For more information on how eco hometec our products and services then contact us on 01302 722266 please post, fax (01302 728634) or email sales@eco-hometec.co.uk plans for quote.

Figure 19 Typical Solar Installation



eco hometec
Unit 11E
Carcroft Enterprise Park
Carcroft
Doncaster
DN6 8DD
Tel. 01302 722266
Fax. 01302 728634

<http://www.eco-hometec.co.uk>

e.mail. sales@eco-hometec.co.uk

