

1. Purpose and construction of ZPS pumping set

Pumping set is designed for installation with solar collectors to constrain and regulate heat carrier flow in hydraulic circulation of collectors and water heater.

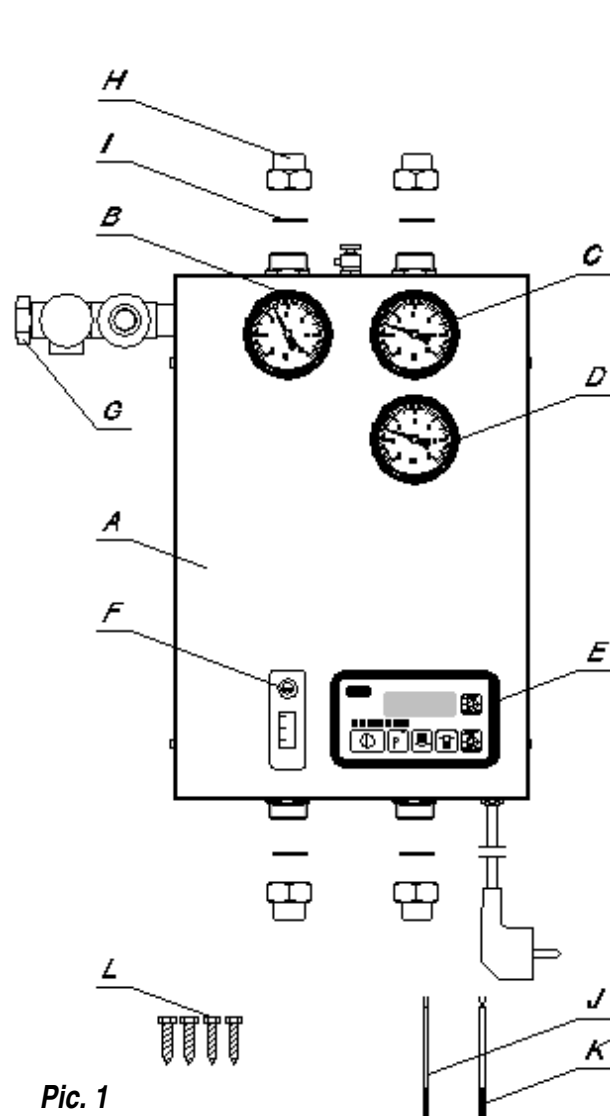

Pic. 1

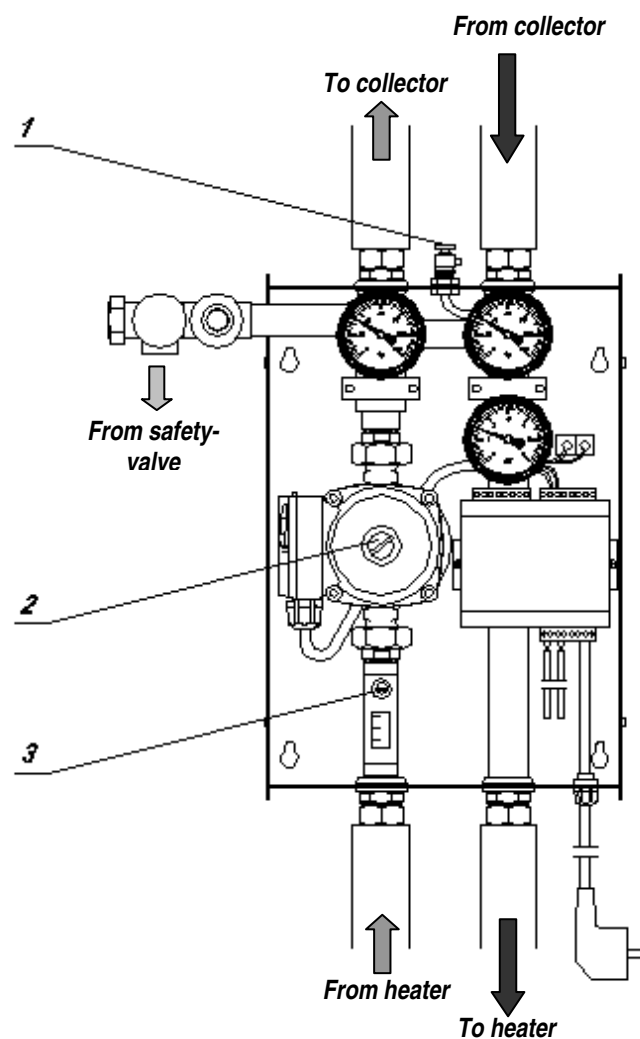

Pic. 2

Included in ZPS pumping set (drawing 1) are:

A – ZPS casing set	B – thermometer	C – thermometer	D – manometer	E – G-403 controller	F – flow indicator
G – Plug or tube of expansion vessel	H – Pipe half union	I – gasket	J – sensor temp. 20mb	K – sensor temp. 3mb	L – clamping screw

2. Montage of pumping set.

- Pumping set is adjusted to being fastened on the wall as far from the water heater as the hydraulic hoses which connect ZPS with coil connector pipes in water heater let it be. Points marked on the scheme attached are to be bored in those exact places to put in screws and fasten ZPS on the wall.
- Mount the air-escape valve (1) with tube in the place marked on drawing.
- Connect ZPS with pipe according to drawing 2.
- Install the expansion vessel using connector pipe (G, pic. 1).
- Connect temperature sensors according to the instruction on the other side.

3. The sequence of filling in and commissioning operations:

The system should be filled with water solution of propylene glycol of crystallization temperature -25°C or lower.

Installation repletion should begin after finishing mounting all the sub-assemblies and checking tightness of soldered and screwed connections of whole hydraulic circuit.

Following operations:

- Connect manual or mechanic pump to fill in the installation with heat carrier, with drain cock, which should be fit in the lowest spot of heat carrier circuit (at the bottom coil connector pipe in water heater).
- Open the air-escape valve in the highest spot of heat carrier circuit (next to the solar collectors).
- Fill the installation with heat carrier using pump until the heat carrier comes to the top of air-escape valve by collectors.
- Close the air-escape valve by collectors and, in construction of total height not bigger than 10m, increase overpressure to required 2,5 bar according to the manometer readings.
- Turn on circulating pump in ZPS using the button (1) "MAIN PUMP" on G403-P10 controller's screen.
- Regulate required heat carrier flow through solar collectors. To achieve that use flat screwdriver and set flow-meter's knob "3" so that float's bottom edge in flow-meter's sight-glass shows required size of flow (1,5 l/min for every solar collector).

7. Vent the installation through air separator placed inside ZPS. To do that, the screw valve "1" on the top of ZPS should be opened for a while. Activity should be repeated until there is no air left in the system.

4. Electronic controller G-403-P10

Controller is a separate regulating block designed for steering circulation pumps as well as other devices with electric drives, which occur in installations with solar collectors. Controller has 3 temperature sensors, which, depending on the choice of one out of six programmatic versions, are to be placed in appropriate temperature measuring points, market on six different technological schemes of installation.

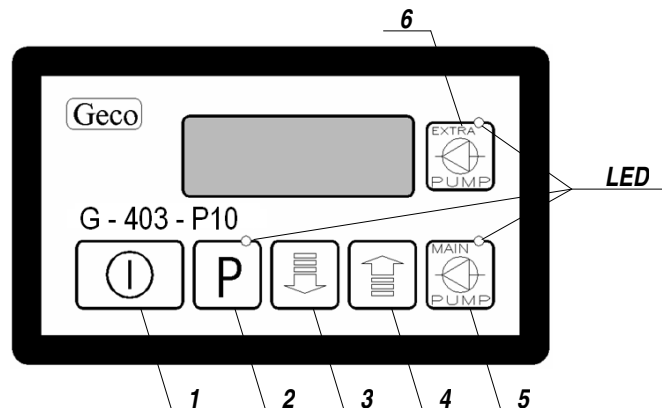

Controller's technical data

- Work's tension → 230V +10% -15%
- Surrounding temperature → from +5°C do +40°C
- Humidity → from 20% do 80% RH
- Protection degree → IP65 from the front side

CAUTION. Total electricity used by devices must not transcend 10A !!!

Performance

After hooking the controller to electricity, its screen will show in order given: four dots, number of program version, four lines signaling stand-by state of controller "live". Activation of the controller follows pushing the button (1). The screen will show the temperature in heater in the spot of placing T2 sensor. Circulation pump activates automatically when temperature of solar collector in placement of T1 sensor is higher by „u0” parameter's value appointed by user (look "Programming user's parameters", point VII from instruction).

Circulation pump can be activated in non automatic (manual) mode using button (5). Circulation pump's work is signaled by shining diode on button (5): blinking light while automatic work; constant light while non-automatic work.

If the temperature of water in heater reaches value of "u1" parameter, circulation pump is automatically turned off(conventionally it is 85°C)

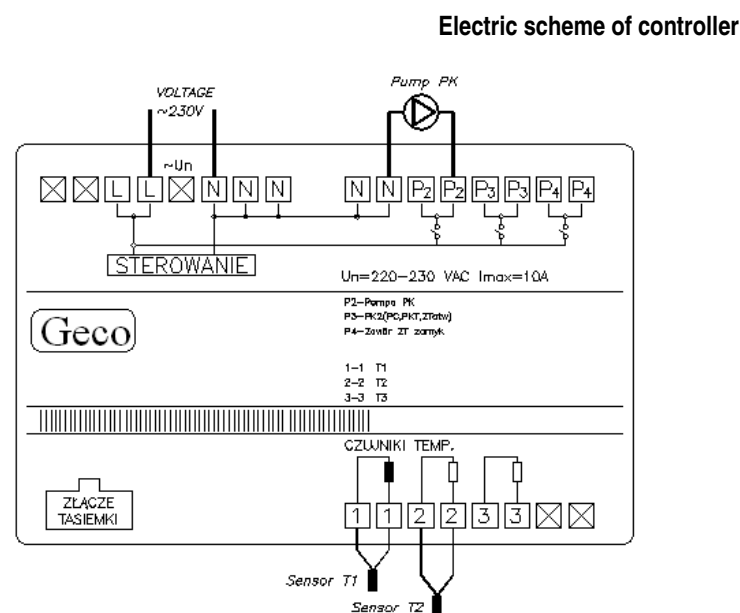
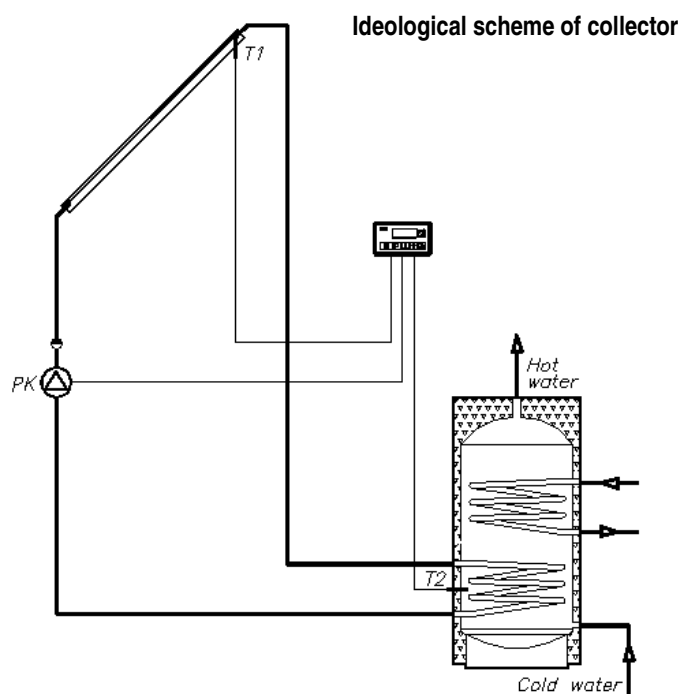

Damages in temperature sensor's electric circuit or damage states of installation are signaled on the screen of controller as follows:

- **AL1** – no electric contact or damage of T1 sensor, temperature of collector over 140°C (no required circulation of heat carrier through the collector)
- **AL2** – no electric contact or damage of T2 sensor.

Signaling of alarm after fixing the device can be removed by pulling spotter out and again hooking the controller to electricity.

During normal work controller shows temperature of water in heater in the place of putting T2 sensor. By pushing the button (4) temperature of heat carrier in solar collector may be seen for a while on the screen.

Programming user's parameters

While the controller is turned on, user's parameters are to be programmed by pushing button (2). After that diode on the button (2) turns on, signaling programming. For 1 second name and number of parameter together with its value may be seen on the screen. Using buttons (3) and (4) its value can be enlarged or reduced. Longer pushing of buttons (3), (4) causes fast rewinding of indications.

Confirm the value set using button (2). It will cause memorization of the value and transfer to next parameter. Program next parameters analogically.

Parameters available to set:

'u0' – (range 2÷15°C) – difference of temperatures (T1-T2) activating collector pump PK,

'u1' – (range 10÷90°C) – maximum water temperature in accumulator (T2), over which pump will be turned off.

CAUTION! Regular setting of 'u0' parameter should be between 4÷8°C. Lower value of parameter should be set if collector is placed close to heater and if there is good wire's isolation.