

DOMESTIC HEATING CONTROLS ARE EASY

PART 1 - THE BASICS

Today's inescapable need to improve energy efficiency in UK homes has brought installers many opportunities to make extra earnings through the upgrading of heating and DHW controls. Often, however, misunderstandings and technical 'mystique' surrounding some of these products inhibits installers from fitting the most appropriate energy saving devices that can cut household heating bills and reduce carbon dioxide emissions into the atmosphere. This series aims to remove some of the doubts and show that domestic heating controls really are easy.

THE CONTROLLED 'WET' SYSTEM

The majority of UK centrally heated homes rely on gas, oil or lpg boilers to supply heated water for radiators and DHW primaries. This publication concentrates on these 'wet' systems, where home comfort levels and fuel economy are usually maintained by:

- a) simple automatic On/Off boiler control to meet demands for heat
- b) directing heated water to cylinder and radiators only when and to where needed.

For optimum efficiency, systems should be correctly sized, hydraulically balanced and fitted with controls that will: -

- maintain heating and stored DHW temperatures at preset levels
- enable radiators to be heated only when and where required
- ensure boilers fire only when heating or DHW are calling
- permit the boiler to achieve its full SEDBUK performance (see **BUILDING REGULATIONS**)

BUILDING REGULATIONS

There are things in our work that we just have to do. For health, safety and environmental reasons, the Building Regulations impose statutory provisions on most aspects of construction work. Unless these requirements are met, premises and installations cannot be legally handed over.

From August 2001, Part L1, *Conservation of Fuel and Power in Dwellings*, applies both to new premises and to existing dwellings whenever a '*controlled service or fitting*' is being supplied or replaced.

For heating installers, this means in effect that, when replacing boilers and hot water cylinders, it is necessary often to upgrade unsatisfactory timing, temperature and interlock controls so that the boiler's declared SEDBUK performance can be fully achieved.

Key requirements of the latest version of Part L1 are: -

1. Applies not only to new build installations but also when boiler or cylinder replacement work is carried out in **existing** premises; and could require additional or new controls.
2. All replacement boilers must be high efficiency types with the appropriate SEDBUK ratings (78% for most gas boilers), and supported by relevant controls to enable the full SEDBUK performance to be achieved.

3. Separate timing and temperature control for space heating and hot water, except with combination boilers and solid fuel appliances.
4. Zone control of space heating to provide separate time and temperature control in areas that have different requirements such as living and sleeping areas, i.e. TRVs or separate room thermostats with motorised valves.
5. DHW cylinders with suitably sized heat exchangers (to BS 1566 minimum) only should be used to prevent wasteful boiler cycling.
6. Cylinders must be insulated to a minimum standard, as well as the first metre of pipe leading from the cylinder.
7. Boiler interlock is required for gas and oil fired systems to switch the boiler *off* when there is no demand for heat. Thermostats should be fully interlocked with the boiler.
8. Systems that use only TRV's should be fitted with a Boiler Energy Control, or a room thermostat electrically interlocked to prevent unnecessary boiler cycling.
9. Heating and hot water systems must be inspected and commissioned after installation to ensure they operate efficiently.
10. The building owner and/or occupier must be given a suitable set of operating and maintenance instructions for their systems.

MINIMUM ACCEPTABLE CONTROLS

The minimum acceptable level of control that allows users adequate operational choice with a single-zone, fully pumped system comprises:-

- a) **a time control** – to provide independent time control of heating and DHW
- b) **a room thermostat** – to control space heating temperatures
- c) **a cylinder thermostat** – to limit the temperature of stored DHW
- d) **motorised valve(s)** – to regulate the flow of heated water to radiators and DHW coil
- e) **electrical interlock system** - to prevent the boiler firing if there is no call for heat

The addition of radiator thermostats (TRVs) and an automatic by-pass valve can increase energy savings and enhance a system's seasonal efficiency.

However, controls can succeed only if the system itself allows them to. For instance, what is the point of fitting a programmer that offers independent control of heating and DHW if these two circuits are not individually controllable? Also, full energy efficiency cannot be achieved with gravity and semi-gravity systems, or where pipework errors exist. It is important, therefore, that every installation provides the basic system requirements for optimum energy saving performance – before any attempt is made to fit controls.

GETTING THE PIPEWORK RIGHT

A disciplined approach to system layout will pay dividends. By following the simple 3-T's Rule (*Fig. 1*), and properly positioning the boiler, feed and vent (*Fig. 2*), installers can ensure a hydraulically correct system and help prevent pumping over, reverse circulation and short circuiting.

3-T's Rule

The simple 3-T's Rule shows how the various take-off and return T's should be connected in order to avoid costly problems and call-backs arising from incorrect system circulation.

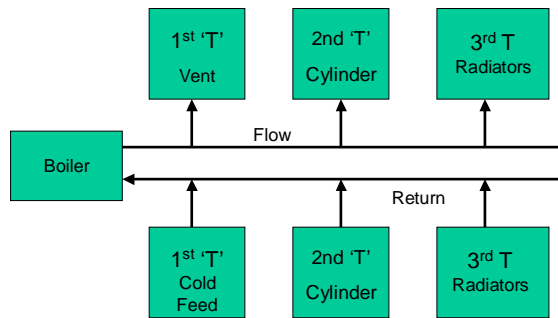

Fig.1 – the 3-T's rule

Remember, numbered from the boiler, the correct order of the pairs of flow and return T's is as follows:-

- 1) **Vent and Cold Feed**
- 2) **DHW Cylinder**
- 3) **Radiators (zone 1)**

Where there are additional heating zones, the same simple logic applies, i.e. heating zone two – 4th pair of T's; heating zone three – 5th pair of T's; etc.

Boiler, Feed and Vent Positions

Correct. The traditional positioning of boiler, cold feed and vent is shown in Fig. 2. It is by far the best arrangement

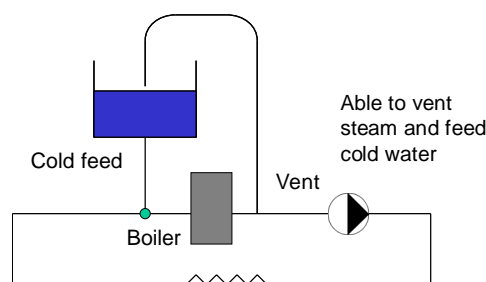

Fig. 2 – Traditional boiler, feed and vent positions

for the vast majority of domestic systems.

Incorrect. The feed and vent arrangements illustrated in Figs. 3 and 4 are unsatisfactory and will almost certainly give rise to problems for the reasons shown

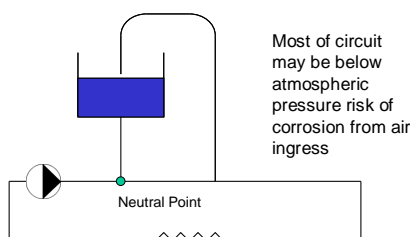

Fig. 3

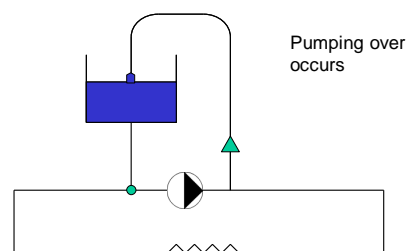

Fig. 4

High Pressure Boilers. Sometimes, with high-pressure boilers, close-coupled feed and vent arrangements (150mm max. between vent and feed) in the flow are permissible subject to the boiler manufacturer's recommendations and the use of additional safety controls such as overheat protection.

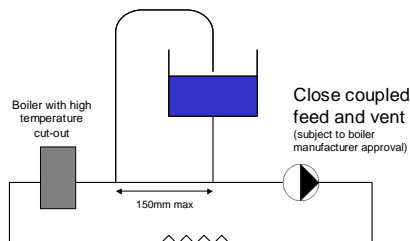

Fig. 5 – High pressure-drop boiler with close-coupled feed and vent

Combined feed and vent systems. The following diagrams (Fig. 6 & 7) show combined feed and vent layouts, where the feed and vent pipes are connected to each other before connection to the system. Not as intrinsically safe as the other arrangements, these options should only be used if recommended by the boiler manufacturer.

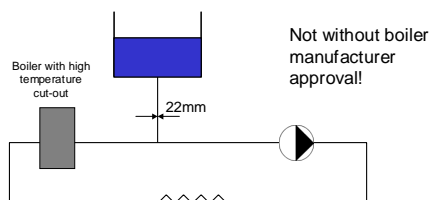

Fig. 6 – Combined feed and vent arrangement (1)

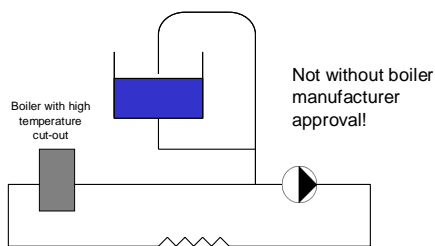

Fig. 7 – Combined feed and vent arrangement (2)

BOILER SIZING

The operating efficiency of boilers decreases with low heating loads. Boilers running constantly at part capacity will most surely waste fuel. Over-sizing, therefore, should be avoided.

Domestic boiler sizing is best based on the BRECSU Whole House method rather than by adding up the final radiator sizes, a practice that can produce significant over-sizing.

SYSTEMS WITH CONVENTIONAL BOILERS

Gravity circulation and semi-gravity systems

These systems cannot achieve full energy efficiency due to their slow response and consequent low controllability. The most cost effective way of improving their energy efficiency is to convert them to fully pumped. The cost of adding controls (programmer, cylinder thermostat and two-port motorised valve (see Fig. 8) is almost as much as conversion to fully pumped – without the benefits.

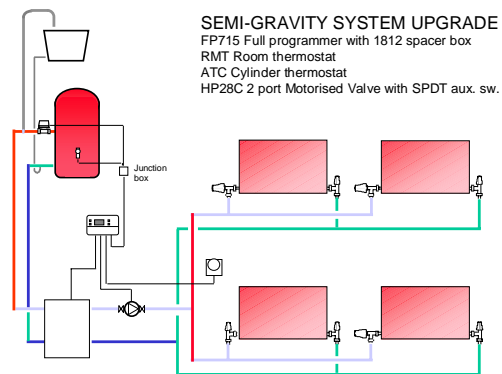

Fig. 8 – Semi-gravity system with controls upgrade

Fully pumped systems

The well-known systems in *Figs. 9 & 10* permit fully flexible, independent time and temperature control of heating and DHW. Programmers and thermostats are not shown. The 3-T's rule has been observed, and the pump, feed and vent are correctly positioned. Attempting a shortcut, e.g. connecting the return from the first floor radiators to the cylinder return, could lead to reverse circulation – heated water entering the radiators from the return - when the heating valve is closed.

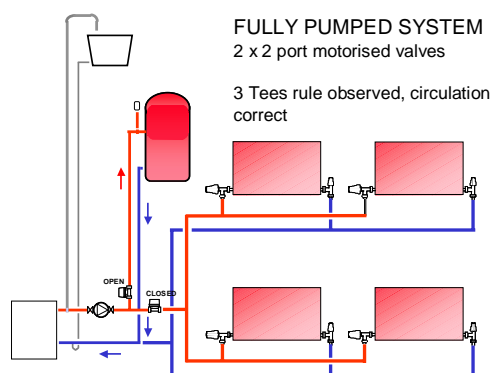

Fig. 9 – Two 2-port motorised valves

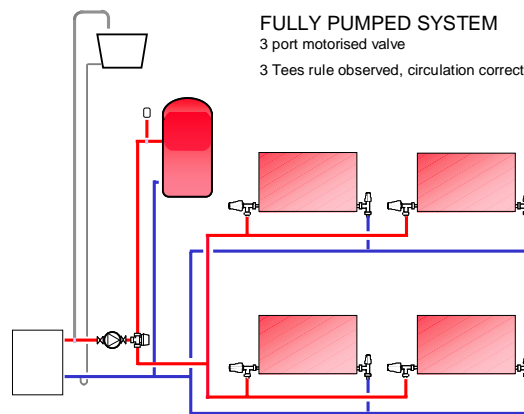

Fig. 7 – Mid-position valve system

COMBINATION BOILER SYSTEMS

Over 50% of all new central heating installations now have combination boilers. They do not require feed and vent systems, or DHW cylinders. Therefore, the 3-T's rule as such does not apply. Nevertheless, care is still required to avoid reverse circulation and/or short-circuiting.

DHW CYLINDERS

These require sufficiently large coils (minimum to BS1566) to allow the cylinder to absorb heat quickly. Larger coils have particular benefits with condensing boilers.

A WORD ABOUT THE ELECTRICS

Most installers should find making the simple electrical connections required for domestic heating controls well within their capabilities. Full instructions are invariably included with every new control device or pack and this series of publications will deal elsewhere with the wiring of individual controls and control systems. However, it is strongly recommended that those intending to do their own wiring and commissioning should attend a suitable electrical training course.

A) Field (First-fix) Wiring

In practice, installers will be wiring each component back to a wiring centre or junction box. It is, therefore, important to know the number of cores that are required for each cable. Manufacturers usually present this information as a Field Wiring Diagram as shown below (Fig. 8). The cables are usually presented as, for example, "3+E", which means that three cores are required from the connection, plus an earth if the component requires it. Double insulated components do not require an earth, but it is good practice to leave an earth conductor available.

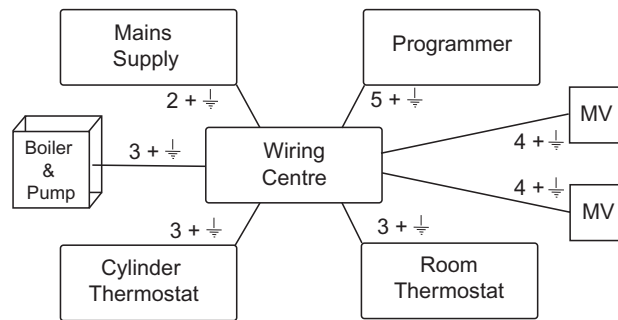

Fig. 8

B) Mains Connection

To comply with the latest wiring regulations, mains power for the boiler, pump and controls should be connected to a domestic heating system via a double-pole, switched and fused (3A) fixed spur with an On/Off indicator.

C) System Tests

Four basic tests should always be carried out on any appliance or control system before connection to the mains – earth continuity, short circuit check, resistance-to-earth and polarity. Failure in any one test means that the appliance should not be connected.

1) Earth Continuity Check

This test ensures that all the metal parts of the system are correctly bonded to the earth leading away to the supply. Failure means that, in the event of a fault, the appliance could remain live and this would not be detected until someone received an electrical shock

A suitable meter should be used to measure the resistance in Ohms (Ω) from the earth connection of the double pole isolation switch to all metal parts of the case, pump, etc

The reading should be less than 1Ω . A higher value represents failure and the appliance should not be connected.

2) Short Circuit Check

A short circuit in the system will immediately blow a fuse when connected and possibly damage some of the components

A suitable meter should be used to measure the resistance in Ohms between the neutral and live terminals. Because of the large number of potential live circuits that may be electrically isolated when powered down (switches open) this test should be carried out on the wiring or terminal block

The testing between the neutral and various live or switched live terminals should always read greater than 1Ω . A lower value indicates short circuit failure

3) Resistance-to-Earth Check

This ensures that the appliance or system does not have a leakage to earth. The basic test uses a suitable meter to measure the resistance between Earth and the live or switched live terminals. The meter must read infinite resistance at its highest ohms range, lower than this indicates a fault or failure. This test is best done at a wiring or terminal block since this gives best access to most switched live circuits.

4) Polarity Check

The aim of this test is to detect whether the boiler or system's live, neutral and earth are connected the correct way round.

The mains supply is connected and a suitable meter used to measure the voltages across the L, N and E terminals. The meter should be set to a suitable AC Volts scale (normally 300Vac or higher) and the results should be in accordance with the following.

- L-N meter should read approx 240 V ac
- L-E meter should read approx 240 V ac
- N-E meter should read approx 0-15 V ac

Any other readings indicate a polarity check failure and that the appliance should be disconnected.

D) Pipework Bonding

Pipework bonding is an important requirement of the electrical regulations. Gas and water pipes should already be bonded to the earth in the main electricity distribution box. In addition, radiators and pipework in the bathroom should be bonded directly to the main electricity distribution box.

IT'S EASY!

Hopefully, this guide will have shown that getting a heating system right comes down to plain commonsense - not obscure, mysterious skills that only a few can learn. Anyone with basic plumbing training can do it – it's easy. This series will go on to show this applies also to the operation, selection and installation of heating and DHW controls.