

DOMESTIC HEATING CONTROLS ARE EASY

PART 4 - MOTORISED VALVES

Motorised valves in 'wet' central heating systems control the flow of heated water from the boiler to primary circuits, i.e. to radiators and DHW cylinder coils.

Operated by small (5W or 6W) synchronous electric motors and activated by time controls and thermostats, they help maintain desired comfort levels and save fuel by ensuring heated water goes only to where it is needed – and when.

Although expected to perform reliably for years, the arduous nature of a motorised valve's duty cannot be overstated. It must operate for long periods daily and cope with frequent temperature and pressure fluctuations as well as grit, scale, sludge and possibly chemicals in the flow water.

Danfoss Randall Ltd. produces comprehensive ranges of robust, high quality motorised valves for all domestic heating applications and for all preferences. These products are based upon proven traditional designs that have been refined to introduce additional strength and operational benefits.

TYPES

The most widely used motorised valves are *Two-Port Zone* and *Three-Port Mid-Position* types. Typical examples are shown in Figs. 1 & 2. *Three-port diverter valves*, similar in appearance to a mid-position valve and once used in hot water priority systems, are now less popular.



Fig. 1. Danfoss Randall 2-port motorised valve – 1 inlet port and 1 outlet



Fig. 2. Danfoss Randall mid-position motorised valve – 1 central inlet port and 2 outlets.

Two main closure mechanisms are encountered.

1. The *sliding shoe type* (Fig. 3) has a spring-loaded shoe that slides against the inside wall of a cylindrical valve chamber to shut off or open ports as required. The hardwearing, low friction shoe slides on a thin lubricating film of system fluid.

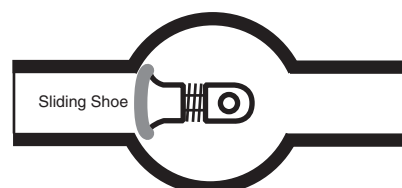

Fig. 3. Diagrammatic plan view of a shoe valve.

2. The *swivel paddle type* (Fig. 4) has a swing arm with a flat-faced rubber paddle (or rotating ball) that sits firmly across the machined face of a tubular outlet insert, providing 100% tight closure.

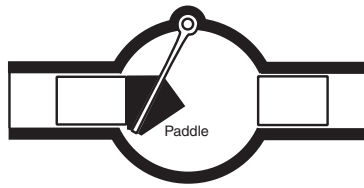

Fig. 4. Diagrammatic plan view of a paddle valve.

Both methods have stood the test of time for many decades and choosing one against the other is often down to personal preference. Sliding shoe valves were initially very popular in the UK and are still widely used. Their simple construction, without the need for outlet port inserts, and hardwearing shoes gave them a high level of dependability. These valves allow a minimal amount of seepage because of the lubricating film of system fluid on which the shoe slides.

The paddle valve, on the other hand, provides the purist energy-saver with 100% tight shut-off. Manufacture is slightly more complex with accurate positioning of the outlet port inserts a necessity. There is virtually no possibility of scale or solids becoming trapped in the valve chamber and paddle valves are often described as self-flushing. Most domestic motorised valves are equipped with simple mechanical position indicators that show at a glance which ports are open. Also, they have manual levers that allow them to be opened and locked as desired for system testing, especially when electric power is not yet available on site.

OPERATION

Consisting of valve bodies and drive actuators, some valves are supplied fully assembled whilst others come in two separate parts, i.e. with detachable actuators.

When energised, drive motors rotate the valve spindle to open or close appropriate valve ports. There are two basic modes of operation: -

- a) *Power Open/Power Close* – Shoe type. Rotate in one direction. Switched by thermostats with *changeover* output contacts to ensure power is available to close them when heat demands become satisfied. Less popular due to their additional wiring.
- b) *Power Open/Spring Close* – When powered, the motor drives the swivel paddle or shoe until it is held against either an appropriately positioned mechanical stop or the opposite outlet port. When de-energised (thermostat satisfied) a powerful spring returns the mechanism to its original position.

2-port Spring Return Valves

When energised, the motor drives the paddle or shoe open to a central position within the valve chamber. Water flows around and through the outlet port. The spring closes the valve when the thermostat becomes satisfied and cuts the power to the motor.

Many, but not all, 2-port valve actuators incorporate auxiliary (end) switches that energise boiler and pump when the valve opens – see Fig. 5. These switches, which are electrically isolated from the motor power supply, provide the Building Regulations' interlock requirement for preventing boiler firing when no heat demand exists.

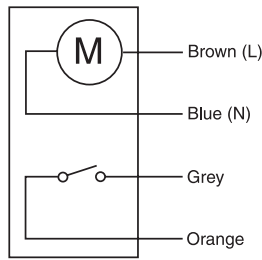

Fig 5

3-port Diverter spring return valves

These are usually supplied with heating ports closed. When energised, the paddle or shoe drives fully across to close the DHW port, allowing flow to the radiators. Disconnecting power allows the spring to close the CH port again. Thus, flow is permitted to either radiators or cylinder coils – but not both at the same time.

3-port Mid-Position spring return valves

Simple internal switching and circuitry allows flow to either heating or DHW individually - and to both ports simultaneously. Operation relies on the close, but separate, action of two cam-operated switches and the use of a voltage-reducing resistor or diode.

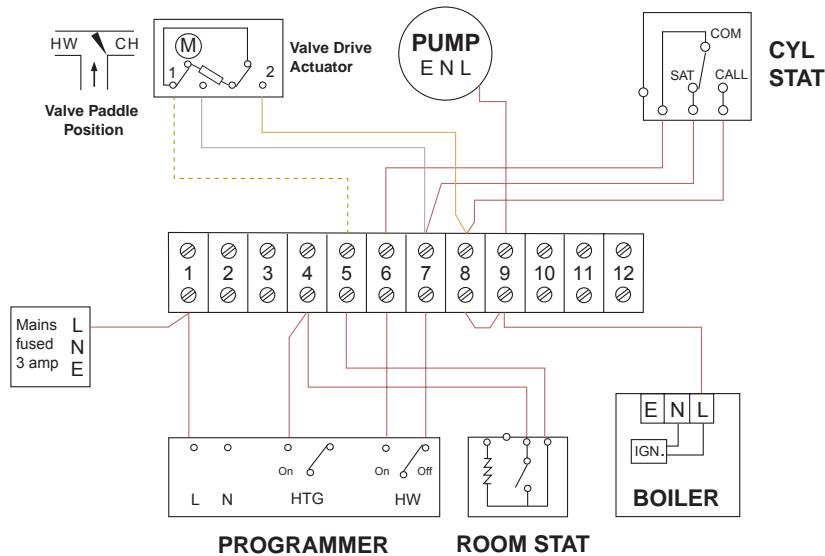

Fig. 6. Wiring for mid-position valve system - valve de-energised with both room and cylinder stats satisfied. N and E connections not shown for clarity

In Fig. 6, both room and cylinder thermostats are shown satisfied and both Heating and DHW are timed 'Off'. The valve (top left) is closed to CH.

Now let us trace the circuit through as the following changes occur.

1. Heating comes on, room thermostat calls for heat (Fig. 7).

a) Valve motor (Fig. 6) receives full power via brown/white lead (terminal 5) and through valve switch 1. (Although switch 1 is linked to switch 2, a resistor inhibits supply to the motor.)

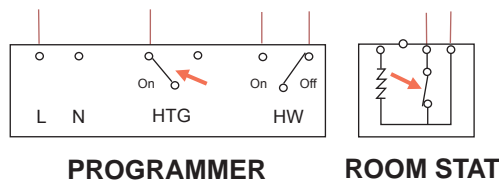

Fig. 7

b) Motor begins to drive, opening CH port and turning two small cams within the drive actuator. Cam 1 makes switch 1 snap over when paddle is halfway (Fig.8). Full drive power continues via grey lead (terminal 7) from satisfied cylinder stat.

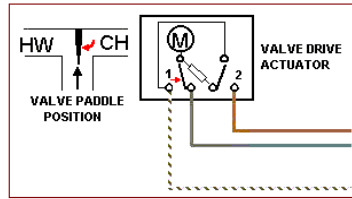

Fig. 8

c) After turning a few degrees more, cam 2 operates switch 2 (Fig. 9).

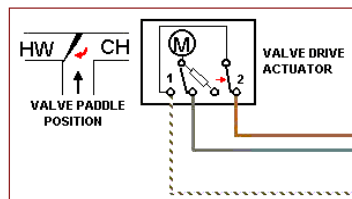

Fig. 9

This sends power (link from switch 1) via the orange lead to operate boiler and pump. Valve drives across fully to close DHW port. The radiators warm up.

2. Cylinder Stat calls for heat (Fig. 10)

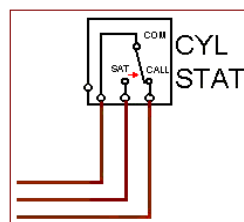

Fig. 10

a) Cylinder stat transfers power to wiring centre terminal 8 (linked to 9), continuing to operate boiler and pump.

b) The grey lead (terminal 7) to the motor is de-energised; valve paddle starts to spring return.

c) Cam 2 changes Switch 2 back (as Fig. 8). Power passes through the resistor, feeding the motor a reduced voltage just sufficient to hold the paddle stationary against the spring, i.e. in mid-position. Heated water can then flow through both outlet ports. Both CH and DHW are operative.

3. Heat Calls satisfied - valve stays in Port of last call

a) Then, if CH becomes satisfied first, the power supply through the brown/white lead to the motor is removed. The paddle returns, closing the CH port. To maintain DHW, boiler and pump receive power via wiring centre terminals 8/9.

b) Should DHW become satisfied first, the cylinder stat transfers power to the grey lead (terminal 7) causing the motor to drive fully over and close the DHW port. Boiler and pump remain powered via the orange lead. CH only is operative.

c) If both CH and DHW programmes then time out (switch off), the motor still receives power via the programmer's DHW 'Off' terminal and the grey lead (terminal 7), thus holding open the CH port. However, no power can reach pump or boiler until the programmer re-starts.

VALVE SIZING

Each type of valve, depending on its size, construction and the maximum differential pressure at which it should operate, has a finite maximum throughput. Its coefficient of flow (Kv) indicates the volume of water that valve will pass with a pressure drop across it of 1 bar. Shoe valves in general provide a slightly higher throughput than paddle valves. Full details for Danfoss Randall valves can be obtained from Data Sheet 226, available on request.

For simplicity, a 22mm Danfoss Randall valve (2-port or 3-port) is suitable for most domestic central heating systems in the UK. It will handle pumped flow of up to at least 5.8m³/hr at its maximum differential pressure of 1 bar. Under the same conditions, 15mm valves for smaller systems or zone heating will handle a pumped flow of up to at least 3.0m³/hr.

For larger or semi-gravity systems, 28mm or 1" valves obviously have greater throughput but, because of their greater paddle area, their maximum differential pressure must be limited to 0.7bar to allow the motor to open and the return spring to close the valve satisfactorily.

SEMI-GRAVITY SYSTEMS

When upgrading semi-gravity heating systems, compliance with the 2002 Building Regulations will mostly require conversion to fully pumped. However, existing gravity circuits not convertible to the preferred fully pumped option may be retained provided the controls are upgraded. Each upgrade (see Fig.11) should include a cylinder thermostat and zone valve to control DHW temperature, a room thermostat, at least a single output programmer and TRV's on all radiators in the sleeping areas.

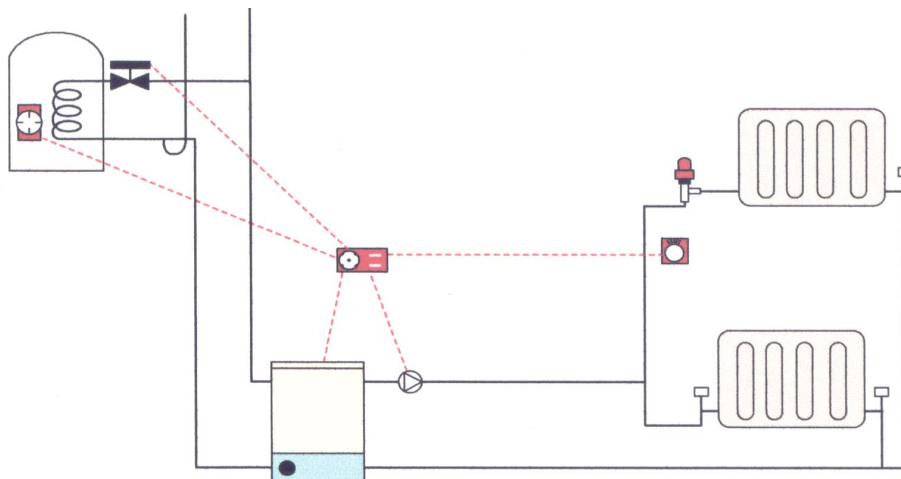

Fig. 11. Control system for semi-gravity system that cannot be converted to fully pumped.

The 28mm/1" 2-port zone valve requires to be fitted with a changeover (SPDT) auxiliary switch, connected as in Fig. 12 below.

1. Whilst the cylinder stat remains satisfied, the motor is de-energised and the valve stays closed to the DHW coils; CH is maintained by the feed from the room stat on the white lead.
2. As soon as the cylinder stat calls, the motor becomes energised and drives the valve open. The auxiliary

switch changes over to continue the power supply to the boiler (even if CH is satisfied).

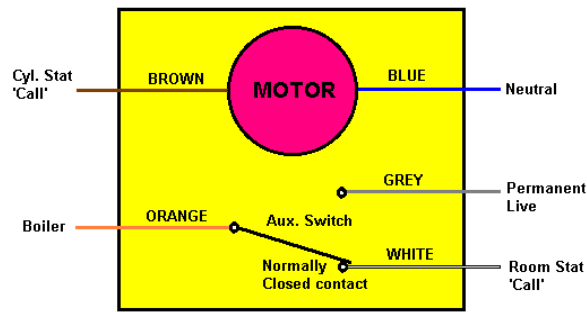

Fig. 12. Connections for 28mm/1" 2-port valve used to upgrade semi-gravity system.

INSTALLATION

Motorised valves, often installed in the airing cupboard, require a reasonable surrounding air space to allow heat from pipework and motor to dissipate. Any mounting position is acceptable except with the actuator directly beneath the valve.

Valve body installation is a comparatively simple plumbing job, connecting to copper pipe by means of compression fittings and olives. Copper tubing should be cut square and de-burred. Valves for steel pipes are usually BSP female threaded. The manufacturer's instructions should be followed to ensure the ports are connected correctly. Colour-coded, captive flying leads from the actuators simplify electrical connections.

DANFOSS RANDALL VALVES

Whatever the preference or application, installers can be sure of getting Danfoss Randall H Series valves to suit their needs.

Both paddle and shoe types are available in all popular sizes, and they all have detachable actuators that make installation and servicing that much easier. Not only this, the same actuators are common to both types. Complete valve/actuator sets can be purchased or separate components if required.

Two-port, diverter and mid-position valves are available in 15mm, 22mm, 28mm, 1/2", 3/4" and 1" sizes. They are all supplied with 1 metre of captive connecting cable with industry standard colours. Full details of sizes and options can be obtained from the Danfoss Randall Product Selection Guide or the company's relevant Data Sheets that are obtainable free on request.