

CORVEC CELT TS

CONFORMS WITH EUROPEAN STANDARD EN 26
(BS 5386 Pt 1)

installation

servicing requirements

contents

Page 3	: TECHNICAL DATA
Pages 4 and 5	: INSTALLATION
Pages 6 and 7	: SERVICING INSTRUCTIONS
Pages 8 and 9	: FAULT FINDING CHART
Page 10	: SHORT LIST OF SPARES

GENERAL

The Celt is a gas fired instantaneous water heater. In its basic form it is flueless but can be supplied with a draught diverter.

It is designed to deliver hot water through a swivel spout or to a hot water tap at a sink or basin. (1F). A remote model is also available (2F). The high pressure model is for use directly off the mains, a low pressure model is supplied for use off a tank supply.

Spout model	- High pressure	1F. HP.
Spout model	- Low pressure	1F. LP.
Remote model	- High pressure	2F. HP.
Remote model	- Low pressure	2F. LP.

The installation of the heater must be in accordance with the relevant requirements of the Gas Safety Regulations, building Regulations and the Byelaws of the local Water Undertaking. It should be in accordance also with any relevant requirements of the local gas region and local authority, and the relevant recommendations of the following British Standard Codes of Practice.

BS 5440	Flues and air supply for gas appliances of rated input not exceeding 60 KW (1st and 2nd family gases).
Part 1	Flues
Part 2	Air Supply
BS 5482	Domestic butane and propane gas burning installations.
Part 1	Installation in permanent dwellings.
Part 2	Installation in caravans and non permanent dwellings.
Part 3	Installation in boats, yachts and other vessels.

technical data

LPG CATEGORY GAS 1₃

Heat input	11.25 kW	38,385 Btu/h
Heat output	8.7 kW	29,600 Btu/h
Gas rate	Propane	0.45 m ³ /h
		0.81 kg/h
	Butane	0.34 m ³ /h
		0.82 kg/h
Burner pressure	Butane	20 mbar
	Propane	25 mbar
Main burner injector	0.68 mm	
Pilot injector	0.15 mm	
Restrictor	2.75 mm	
Water flow rate raised 50 °C (90 °F)	150 l/hr	0.55 gpm
Water flow rate raised 30 °C (54 °F)	250 l/hr	0.92 gpm
Minimum operating head for normal pressure	0.45 bar	6.5 psi
Maximum operating head for normal pressure	10.0 bar	150 psi
Minimum operating head for low pressure	1.3 m	4.26 ft
Maximum operating head for low pressure	24.0 m	80 ft

Note : the minimum water pressure is for the correct operation of the heater only. An additional allowance must be made for the resistance of the pipework and fittings.

Water inlet		15 mm copper
Water outlet		swivel spout
Gas		1/2 in. bsp
Height	420 mm	16.5 ins
Height with draught diverter fitted	540 mm	21.25 ins
Width	228 mm	8.98 ins
Depth	203.5 mm	8.00 ins
Weight	6.9 kg	15.25 lbs
Clearance required for installation and servicing.		
	Top	600 mm
	Bottom	50 mm
	Sides	75 mm
	Front	250 mm

installation

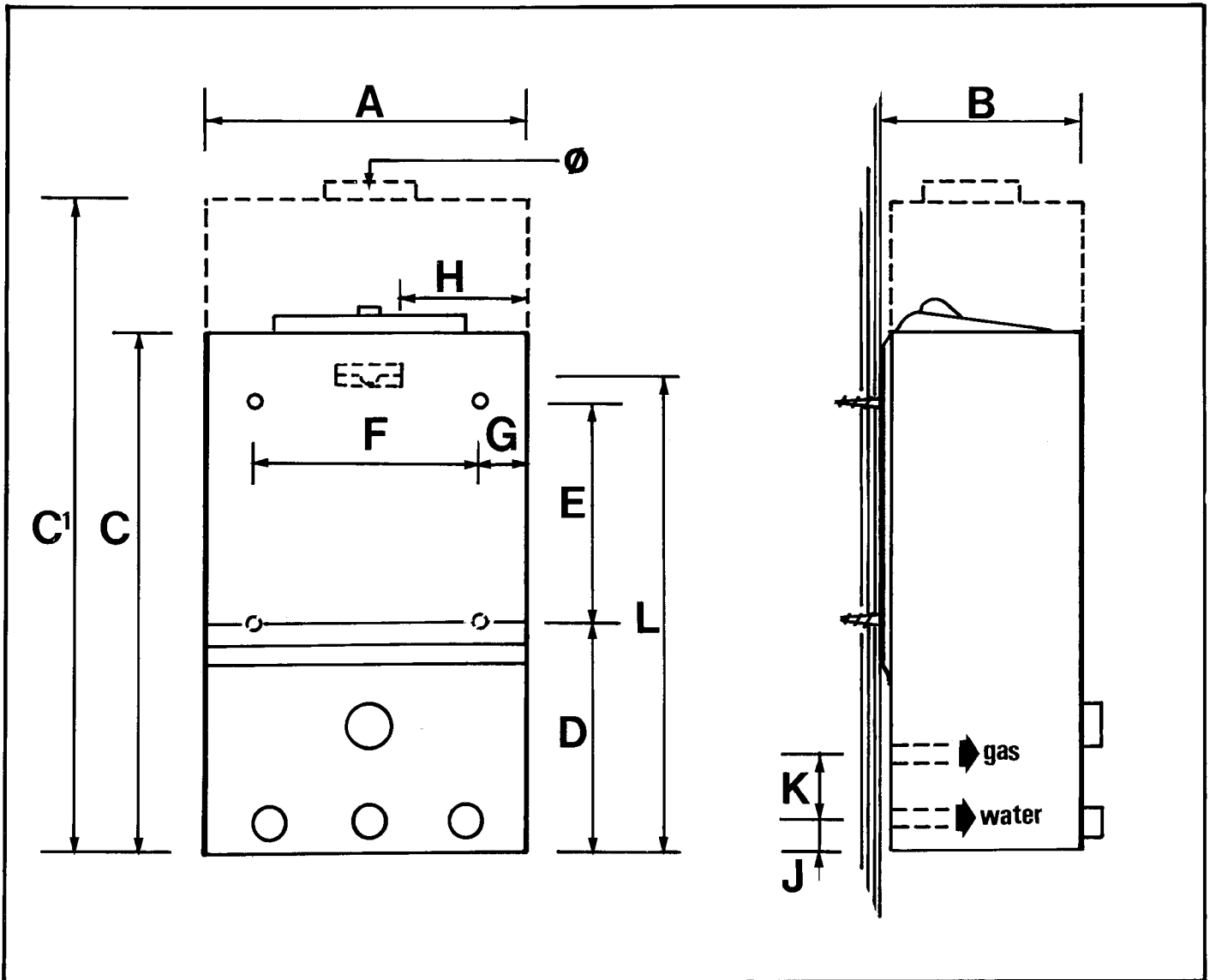

A	B	C	C1	D	E	F	G	H	J	K	L	Ø
228	203.5	420	540	190	175	168	30	90	20	60	390	75 mm

NOTICE

This appliance is for use on LPG and must not be used on any other Gas.

This heater is designed for installation over the sink to deliver hot water either through a swivel spout or to a hot water tap at a sink or basin.

The remote model is designed for direct connection to the tap. These heaters must NOT be connected to a bath hot water draw off, on run continuously for more than 5 minutes. See BS 5546.

installation

VENTILATION

Important : This heater should be used in a well ventilated room. An air vent direct to outside is required of not less than 35 cm² free area, plus an openable window in the room or internal space in which it is installed. These heaters must NOT be fitted in a space where the total volume is less than 6 m³.

FIXING

The heater will be received with the outer cover in position. All the necessary water, gas fittings and knobs will be found in a separate package inside the carton.

Remove the four screws (two top, two bottom, rear of heater). The outer cover & flue deflector can be removed by pulling forwards.

When selecting a position for the appliance there must be a minimum clearance of 600 mm (24 in) between the top of the appliance and a ceiling.

If the heater is to be fitted to a wall likely to be effected by heat the wall **MUST** be protected by a sheet of incombustible material.

The heater should be hung on the wall by means of fixing screws. It is recommended that the heater be positioned 5' 6" (1,7 m) above the floor for convenience of adjustment and maintenance.

It is secured using four fixing screws (two top and two bottom) or by using the bracket provided together with two screws as the bottom of the heater.

GAS CONNECTION

The heater should be provided with a suitable gas service tap.

The connection on the heater is 12 m copper tube.

WATER CONNECTION

The water inlet is suitable for connection to a 15 mm copper supply pipe.

The supply to a high pressure model must be connected from the mains supply.

Permission from the local Water Authority must be obtained before connecting the heater to the main supply.

A head of 15 ft. is required to ensure satisfactory operation of the heater at a minimum flow of 0.44 g.p.m.

Fit spout (1 F model)

The hot water draw-off may be connected directly to the base of the heater, using 12 mm copper pipe and the outlet bend provided (2 F model).

FITTING OF DRAUGHT DIVERTER

Fit clip to flue deflector using nut and bolt provided. Fig. 1. Where it is necessary to fit a draught diverter remove the flue deflector. Fit the front fascia securing with self tapping screw-center front. Fit draught diverter and secure with two screws at rear. The flue should be run in 75 mm steel flue to BS 715 and terminate with an approved terminal in accordance with BS 5440 Pt. 1.

PUTTING INTO SERVICE

Open the gas and water service taps. Purge the gas and water supplies. Check for gas and water soundness.

Fit the gas control knob and light the pilot by turning 90° anti-clockwise. It may be necessary to wait for the pilot to purge, if so, wait a few moments then turn to the 'off' position and repeat.

Turn the gas control fully anti-clockwise to the main gas position.

TURN on the tap, the heater will now light.

Check for gas soundness.

Check the burner pressure by fitting a gauge on to the pressure test point on the end of the burner manifold before lighting the appliance. Light the appliance and check for the correct pressure. The correct pressure is given in Table 1, page 3. If the pressure is not correct, check the pressure at the gas bottle. This should be 37 mbar (14 inwg) for propane and 28 mbar (11 in wg) for butane. The heat input is pre-set and non-adjustable.

Remove the gas control knob. Replace the front case. Replace the flue cap where applicable. Replace gas control knob, water tap knobs and water temperature selector knob. The temperature selector spindle should be screwed fully in, and the knob then positioned opposite (+). Hand the User's Instructions to the consumer and instruct in the safe operation of the heater.

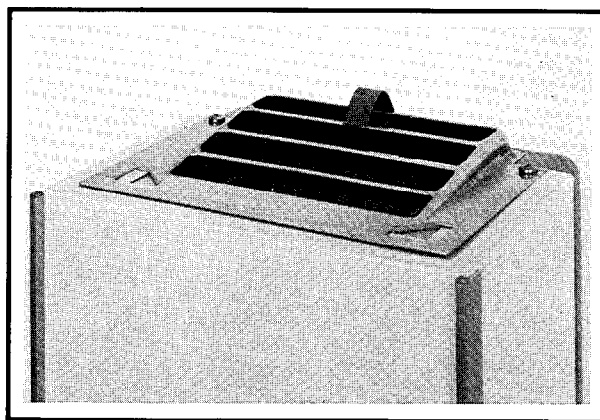

Fig. 1

servicing instructions

Turn off the gas at the gas inlet tap and water at the inlet water service tap before commencing servicing. Before servicing the gas or water sections it will be found easier if the heating body is removed.

1) Front Casing

- To remove casing.
- Pull off the gas control knob, the temperature selector button, and the handles of the taps.
- Remove 4 screws (2 top, 2 bottom).
- Remove the outer cover by pulling forward.

2) Burner (fig. 2).

- Unscrew the pilot tube clamping screw A., release sample tube and remove clamp and tube.
- Remove burner manifold by unscrewing fixing screws B.
- Pull burner head assembly forward to remove, take care not to trap the thermocouple or ignitor wires.
- The burner heads can be cleaned by brushing.
- Replace in reverse order, make sure that the gasket between the manifold and the gas section is in place and that the burner head assembly is correctly located on the spigot at the rear.

3) Heating Body

- With the front casing unscrewing removed, the heating burner and flue body can be inspected and cleaned in position.
- To remove, drain the heater by unscrewing the water regulator A (fig. 6) collecting the water in a basin below the heater (See Sect. 9).
- Remove the burner, see Section 2.
- Remove the screw holding the bottom of the heating body skirt to the rear case.
- Release the two union nuts joining the heating body legs to the water section.
- Remove the heating body lifting upward off top bracket.
- Clean the heating body by brushing with hot water and detergent.
- Re-assemble in reverse order, do not forget to replace the skirt fixing screw and reinforcing strip.

4) Pilot (fig. 3).

- Remove front casing, see Sect. 1.
- Unscrew the pilot tube clamping screw A and remove the clamp and tube (fig. 2).

- Blow through the tube to remove any dust.
- Remove the burner, see section 2.
- Unscrew the knurled pilot burner outer ring A (fig. 3).
- Unscrew the pilot body B with a 15 mm spanner or an adjustable spanner. It may be necessary to remove the heating body. Clean by blowing or washing in water. Do not clean the holes with a wire.
- Blow any dust out of the gas section.
- Re-assemble in reverse order.
- Pilot flame height should be approx. 7 m.m.

5) Thermocouple (fig. 4 and 5).

- To replace.
- Remove front casing, see Section 1.
- Remove the burner, see Section 2.
- Remove the pilot, see Section 4.
- Unscrew the thermocouple nut A from the thermo-electric valve and remove it from the wire (fig. 5).
- With a 7 m.m box spanner, unscrew the nut E (fig. 4) holding the thermocouple into the gas section.
- Thread the thermocouple and wire up through the gas section.
- Replace in reverse order.

Thermocouple output should not be less than 15 m.v. The m.v. output should be checked with a m.v. meter.

6) Spark Electrode (fig. 4).

- To replace.
- Remove front casing, see Section 1.
- Remove the burner, see Section 2.
- Remove the electrode fixing screw F with a screwdriver placed inside the heating body skirt.
- Pull off the electrode cable from the piezo cartridge.
- Lift the electrode out of the gas section.
- Re-assemble in reverse order, and note that the slot in the connector on the end of the electrode cable is vertical when pushed on to the cartridge.

7) Thermoelectric Valve.

- Remove front casing, see Section 1.
- To replace, remove the thermocouple nut A (fig. 5).
- Unscrew cap from the side of the gas section and withdraw the thermoelectric valve.
- Re-assemble in reverse order.

Note : This heater is fitted with a safety interlock. When the pilot is turned off the heater can not be relit until the thermocouple cools down and the lighting sequence is repeated.

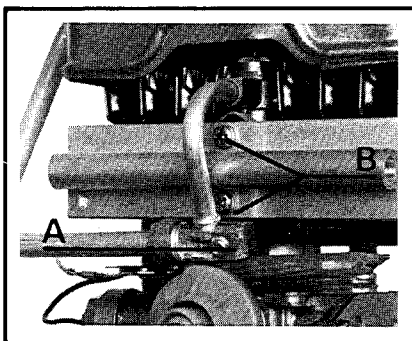

Fig. 2

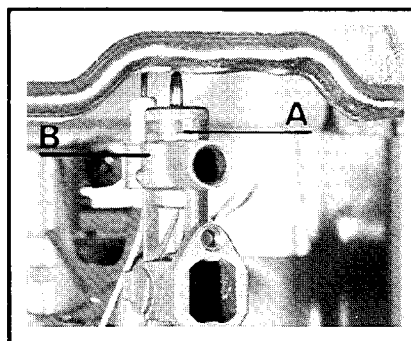

Fig. 3

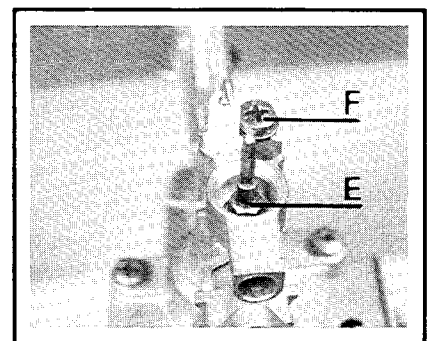

Fig. 4

servicing instructions

8) Main Gas valve.

- Remove front casing, see Section 1.
- To inspect and clean, remove burner, see Section 2.
- Disconnect the thermocouple and the ignitor lead.
- Remove the four fixing screws fastening the top of the gas section to the base. Also the two screws at the back holding it to the rear case.
- Lift the gas section top off the base.
- Remove the gas valve spring.
- Lift out the gas valve.
- Clean the valve seating.
- Check movement of push rod. Clean if necessary.
- Replace the facing rubber if necessary.
- Replace in reverse order.

9) Diaphragm (fig. 6).

- To replace, turn off the cold water supply and gas.
- Remove casing, see Section 1.
- Drain the heater by removing the water governor plug A situated in the base of the water section.
- Unscrew the water unions B on the water section.
- Unscrew the six screws C holding the water section to the gas section.
- Remove the water section complete with the diaphragm and bearing plate.
- Replace in reverse order - NOTE - fit the water governor last. It is easier if the cold water inlet connection is partially engaged before fitting the screws and reconnecting the union nuts.

10) Water Governor

- To clean, turn off the cold water supply to the heater.
- Remove casing, see Section 1.
- Remove the governor situated in the base of the water section A (fig. 6).
- Clean the components with water.
- Check that the spring loaded piston moves freely.
- Replace in reverse order.

11) Gas Filter (fig. 7).

A gas filter is fitted between the gas service tap and the heater.

- To clean, remove front casing, see Section 1.

- Turn off gas at service tap.
- Unscrew the union nut attaching the tap to the heater.
- Lower the union nut and withdraw the filter.
- Replace filter if necessary (G. fig. 7).
- Replace in reverse order.

12) To replace the Piezo Ignitor Cartridge.

- Pull off the electrode lead from the cartridge.
- Remove the screw holding the gas control cam.
- Pull the cam off the spindle.
- Remove the two screws holding the retaining plate in position.
- Remove the plate and then Piezo Cartridge.
- Replace in reverse order, note the slot in the end of the electrode cable is vertical when pushed on to the Piezo.

13) Heat Input.

The heat input is pre-set and non-adjustable. The heat input and burner pressure should be checked against Table 1. by fitting gauge to the pressure test point on the burner manifold.

If the gas rate is not correct, check the working pressure at the pressure test point on the test point on the storage cylinder and adjust the pressure regulator in accordance with the data in Table 1, the gas installation should be examined for any possible blockage if the pressure is incorrect.

RECOMMENDED SERVICING SCHEDULE.

For efficient and trouble free operation, it is recommended that this heater is serviced annually. The following work should be carried out by a competent person.

- 1) Clean the burner.
- 2) Clean the heating body. (In hard water areas it may be necessary to descale the heating body).
- 3) Clean the pilot and thermocouple.
- 4) Replace the gas filter.
- 5) Clean the water governor.
- 6) Change the diaphragm as necessary.
- 7) In hard water areas it may be necessary to descale the heating body. Use a solution consisting of 5 parts water to 1 part hydrochloric acid. The water should preferably be hot - ADD ACID TO WATER, NOT WATER TO ACID.

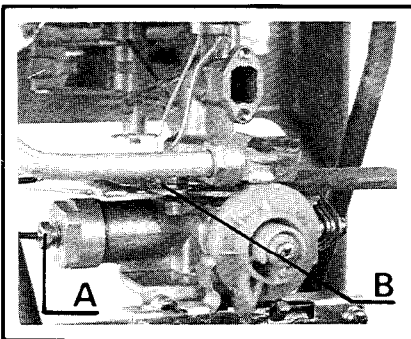

Fig. 5

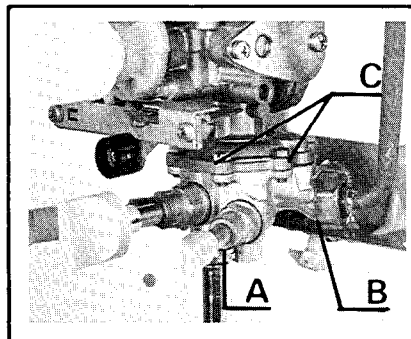

Fig. 6

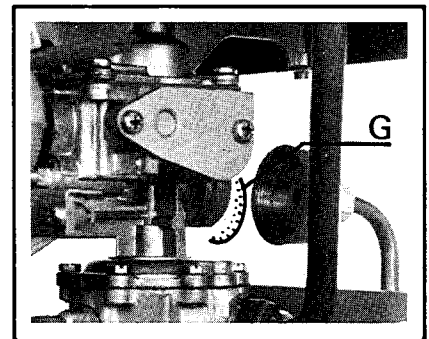

Fig. 7

fault finding chart

PROBLEM	CAUSE	REMEDY
PILOT FLAME DOES NOT LIGHT	<ul style="list-style-type: none"> i) Gas service cock closed ii) Air in pipe iii) Pilot injector blocked iv) Main filter blocked 	<ul style="list-style-type: none"> Open service cock Purge line Clean or change Change filter
POOR PILOT FLAME	<ul style="list-style-type: none"> i) Pilot injector dirty/damaged ii) Wrong injector iii) Pilot head blocked iv) Faulty pilot tube v) Main filter restricted 	<ul style="list-style-type: none"> Clean or change Change for correct diameter Clean Clean or replace Change filter
PILOT WILL NOT STAY ALIGHT	<ul style="list-style-type: none"> i) Thermocouple not working ii) Thermo-electric valve faulty iii) Gas pressure low/variable iv) Gas pressure too high 	<ul style="list-style-type: none"> Change thermocouple Change valve Check at inlet to heater Check pressure at meter
MAIN BURNER DOES NOT LIGHT	<ul style="list-style-type: none"> i) Gas service tap not open fully ii) Gas pressure low iii) Water rate low iv) Gas valve push rod jammed v) Diaphragm vi) Gas tap vii) Injector size 	<ul style="list-style-type: none"> Open fully Check at manifold and at inlet with heater running Check if water rate is sufficient (page3) Clean rod Change diaphragm Check operation of User's gas control tap Check burner injectors are for natural gas 0,68 mm diameter
EXPLOSIVE IGNITION	<ul style="list-style-type: none"> i) Pilot 	<ul style="list-style-type: none"> Check: length is 7 mm and clean injector if necessary
WATER TEMPERATURE LOW	<ul style="list-style-type: none"> i) Water rate too high ii) Insufficient gas flow iii) Water governor sticking 	<ul style="list-style-type: none"> Check water regulator rate Check gas rate and that the gas service cock and user's control are open Remove and clean or replace

fault finding chart

PROBLEM	CAUSE	REMEDY
BURNER STAYS ON	<ul style="list-style-type: none"> i) Air in draw off ii) Gas valve push rod jammed iii) Gas valve "letting by" iv) Loose jumper on house stop cock v) Dead-leg on system vi) Dirt in water section 	<ul style="list-style-type: none"> Purge line Clean push rod Change valve facing Replace water stopcock or pin down jumper Vent or remove Clean water section
YELLOW FLAMES SOOT FORMED	<ul style="list-style-type: none"> i) Heating body fins blocked ii) Primary air supply restricted iii) Wrong injector 	<ul style="list-style-type: none"> Remove heating body and clean Check manifold Check gas type and injector
UNSTABLE FLAMES	<ul style="list-style-type: none"> i) Water in gas line ii) Inlet pressure too high for governor iii) Faulty flue 	<ul style="list-style-type: none"> Purge Check pressure Check flue
HEATING BODY NOISE	<ul style="list-style-type: none"> i) Scale 	<ul style="list-style-type: none"> Descale heating body
INSUFFICIENT WATER FLOW	<ul style="list-style-type: none"> i) Water service tap partly closed ii) Low water pressure iii) Water governor faulty iv) Water governor sticking v) Foreign matter in water section 	<ul style="list-style-type: none"> Check it is fully opened Check water pressure Change governor Remove and clean or replace Remove and clean
HEATER SMELLS WHEN NEW	<ul style="list-style-type: none"> i) Appliance newness 	<ul style="list-style-type: none"> Smell will go within a short period of time
HIGH WATER FLOW	<ul style="list-style-type: none"> i) Water governor sticking 	<ul style="list-style-type: none"> Replace

Short list

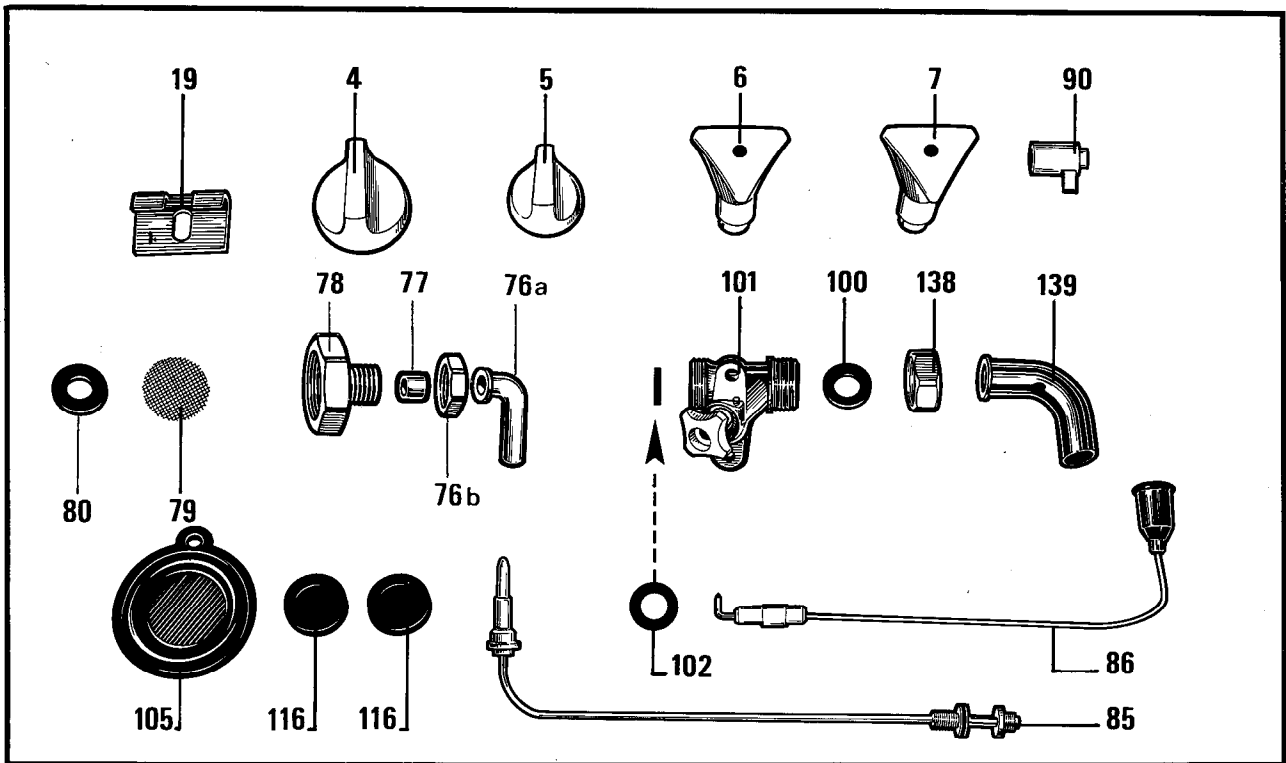

Key No	Description	No Off	Makers Pt.No.
4	Gas control knob	1	39987
5	Temperature selector knob	1	34392
6	Knob - hot water	1	32120
7	Knob - cold water	1	32119
19	Wall bracket	1	44172
76a	Gas supply pipe 12 mm	1	61745
76b	Nut	1	3990
77	Olive	1	3989
78	Gas connection	1	22063/30
79	Gas filter	1	36938
80	Washer - gas connection to gas section	1	22833/10
85	Thermocouple	1	37830
86	Electrode and lead assembly	1	34239
86a	Thermoelectric valve	1	34346
90	Piezo cartridge	1	20267
100	Washer	1	22829/14
101	Water service cock	1	45993
102	Washer	1	22829/14
105	Diaphragm	1	25809/10
116	Tap washers	2	5579
138	Nut (water inlet bend)	1	29516
139	Water inlet bend	1	41594

CHAFFO TEAUX LIMITED
 Concord House Brighton Road
 Salfords - Redhill
 SURREY RH1 5 DX
 HORLEY (02934) 72744

Notes

