

Our policy is one of continual improvement in design and development, therefore strict accuracy of illustrations and descriptions cannot be guaranteed.



This appliance conforms to the following EEC Directive:

Gas Appliances  
90/396/EEC

Low Voltage Equipment  
72/23/EEC  
93/68/EEC

Electromagnetic Compatibility  
89/336/EEC  
92/31/EEC  
93/68/EEC

**Cannon**   
THE FIRST NAME IN GAS

*Creda Limited,  
PO Box 5, Grindley Lane, Blythe Bridge,  
Stoke-on-Trent ST11 9LJ.*

*Sales: Telephone: 01782 385500 Facsimile: 01782 385544*

*Service: Telephone: 0541 500 500*

*Customer Care: Telephone: 01782 385550 Facsimile: 01782 388360*

*Spares: Telephone: 01782 388300 Facsimile: 01782 388289*

**Cannon** 

**CAMBERLEY**

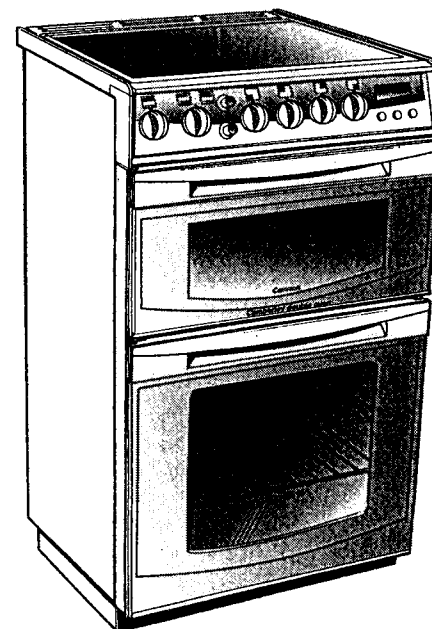

## User's and Installation Instructions

The cooker must be installed in accordance with the regulations in force and only used in a well ventilated space.

**Read these instructions prior to using the cooker and retain them for future reference.**

The Data Badge is located on the rear of the cooker.  
A serial number is located behind the left-hand side of the main oven door seal.

# CONTENTS

	PAGE
INTRODUCTION	3
FOR YOUR SAFETY	4
USER'S INSTRUCTIONS	6
Automatic Cooking	7
Electronic Clock Operation	8
Hotplate	11
Top Oven	12
Top Oven Cooking Chart	13
Grill	15
Main Oven	17
The "E" Setting	18
Main Oven cooking chart	20
Care and Cleaning	22
Spares and Service	24
INSTALLATION INSTRUCTIONS	25

---

## INTRODUCTION

---

To help you make the best use of your cooker, PLEASE READ THIS BOOKLET CAREFULLY.

Your new cooker is guaranteed and will give lasting service. The guarantee is only applicable if the cooker has been installed in accordance with the Installation Instructions.

The cooker is designed specifically for domestic use and responsibility will not be accepted for use in any other installation.

When the cooker is first used, a slight odour may be emitted – this should cease after a short period of use.

## FOR YOUR SAFETY

Please read the precautions below before using your cooker.

- ALWAYS make sure you understand the controls before using the cooker.
- ALWAYS check that all controls on the cooker are turned off after use.
- ALWAYS stand back when opening an oven door to allow heat to disperse.
- ALWAYS use dry, good quality oven gloves when removing items from the ovens.
- ALWAYS take care when removing items from the top oven/grill when the main oven is on, as the contents may be hot.
- ALWAYS keep the oven and grill doors closed when the cooker is not in use.
- ALWAYS place pans centrally over the hotplate burners and position them so that the handles cannot accidentally be caught or knocked or become heated by other burners.
- ALWAYS keep the cooker clean, as a build up of grease or fat from cooking can cause a fire.
- ALWAYS allow the cooker to cool before cleaning.
- ALWAYS follow the basic principles of food handling and hygiene to prevent the possibility of bacterial growth.
- ALWAYS keep ventilation slots clear of obstructions.
- ALWAYS turn off the electricity supply before cleaning or replacing the oven lamp.
- ALWAYS refer servicing to CORGI registered appliance service engineers.

## OPERATIONAL CHECKS

Fit the burner rings, enamelled discs and pan supports and remove any packaging.

With reference to the User's Instructions:

1. Check that the hotplate and grill burners ignite correctly and burn with a steady flame. Check for a steady flame at the low (small flame symbol) setting.
2. Check that with the main oven set to Mark 9, the burner ignites at a low rate and then increases to full rate within 60 seconds. Leave the oven full on with the door closed for 10 minutes and check that the flame reduces when the control is turned the E setting.
3. Check that with the top oven set to Mark 8, the burner ignites at a low rate, and then increases to full rate within 60 seconds. Leave the oven full on with the door closed for 10 minutes and check that the flame reduces when the control is turned to Mark 1.
4. Check operation of timer and main oven light.

Instruct the user on the operation of the cooker.

**NOTE:** It is normal for a slight resistance to be felt when turning the Top Oven/Grill control to the oven settings.

## FOR YOUR SAFETY

- NEVER leave children unsupervised where the cooker is installed as all surfaces will get hot during and after use.
- NEVER allow anyone to sit or stand on any part of the cooker.
- NEVER store items that children may attempt to reach above the cooker.
- NEVER heat up unopened food containers as pressure can build up causing the container to burst.
- NEVER store chemicals, food stuffs, pressurised containers in or on the cooker, or in cabinet immediately above or next to the cooker.
- NEVER fill a deep fat frying pan more than 1/3 full of oil, or use a lid. **DO NOT LEAVE UNATTENDED WHILE COOKING.**
- NEVER place flammable or plastic items on or near the hotplate.
- NEVER use proprietary spillage collectors on the hotplate.
- NEVER use the cooker as a room heater.
- NEVER dry clothes or place other items over or near to the hotplate or oven/grill doors.
- NEVER wear garments with long flowing sleeves whilst cooking.

## USER'S INSTRUCTIONS

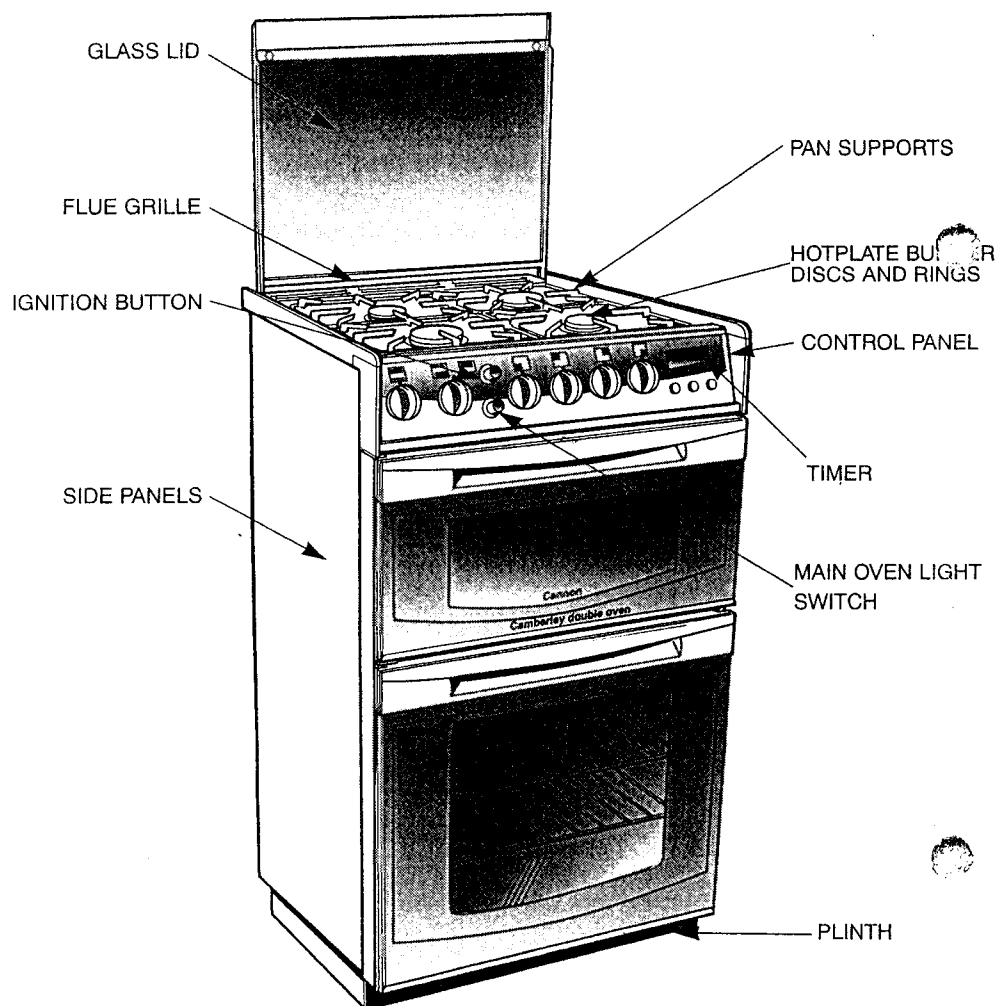

The use of a gas cooking appliance results in the production of heat and moisture in the room in which it is installed. Ensure that the kitchen is well ventilated; keep natural ventilation holes open or install a mechanical ventilation device (mechanical extractor hood).

Prolonged intensive use of the appliance may call for additional ventilation, for example opening of a window, or more effective ventilation, for example increasing the level of mechanical ventilation where present.

## ELECTRICAL CONNECTION

**WARNING – THIS APPLIANCE MUST BE EARTHED.  
CONNECT TO A 230-240V A.C. SUPPLY ONLY.**

Connection to the electricity supply should be made via a properly earthed, readily accessible wall socket which is adjacent to, and not more than 1.25m away from the appliance and capable of electrical isolation.

Should this plug not fit the socket outlet in your home it should be cut off and replaced with a suitable plug as outlined below.

**NOTE:** The removed plug cannot be used for any other appliance and should therefore be properly disposed of and not left where children might find it and plug it into a supply socket – with the obvious consequent danger.

### IF THE FITTED PLUG IS REMOVED

The flexible mains lead must be correctly connected as below to a three pin plug of not less than 13 amp capacity. If a B.S. 1363 fused plug is used, it must be fitted with a 3 amp fuse which is approved to B.S. 1362.

**IMPORTANT:** The wires in the mains lead fitted to this appliance are coloured in accordance with the following code:

GREEN AND YELLOW – EARTH  
BLUE – NEUTRAL  
BROWN – LIVE

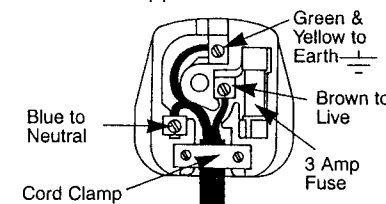

As the colours of the wires in the mains lead of this appliance may not correspond with the coloured markings identifying the terminals in your plug, proceed as follows:– The wire which is coloured green and yellow must be connected to the terminal in the plug which is marked with the letter E or by the earth symbol  $\equiv$  or coloured green or green and yellow. The wire which is coloured blue must be connected to the terminal which is marked with the letter N or coloured black. The wire which is coloured brown must be connected to the terminal which is marked with the letter L or coloured red. When wiring the plug, ensure that all strands of wire are securely retained in each terminal. Do not forget to tighten the mains lead clamp on the plug. As the appliance must be earthed, **do not use** 2-pin sockets outlets, **if you are in doubt, consult a qualified electrician.**

Should the mains lead ever require replacement, it is essential that this operation be carried out by a qualified electrician and should only be replaced with a flexible cord of the same size i.e. 0.75mm<sup>2</sup> cross sectional area.

### IF A MOULDED PLUG IS FITTED

In the event of replacing a fuse in the plug supplied a 3 amp ASTA approved fuse to BS1362 must be fitted.

**NOTE:** The fuse cover must be refitted when changing the fuse. In the event of losing the fuse cover the plug must not be used until a replacement fuse cover has been obtained and fitted. A new fuse cover can be obtained from your local Electricity Board. The colour of the correct replacement fuse cover is that of the coloured marks or inserts in the base of the plug.

## INSTALLATION INSTRUCTIONS

### HOTPLATE BURNER AERATION ADJUSTMENT (LPG MODELS ONLY)

The aeration is adjusted by means of a ring fitted in the centre of the burner body.

1. For Propane gas, G31 the ring **must** be fitted such that the small opening is uppermost.
2. For Butane gas, G30 the ring **must** be fitted with the small opening downwards.

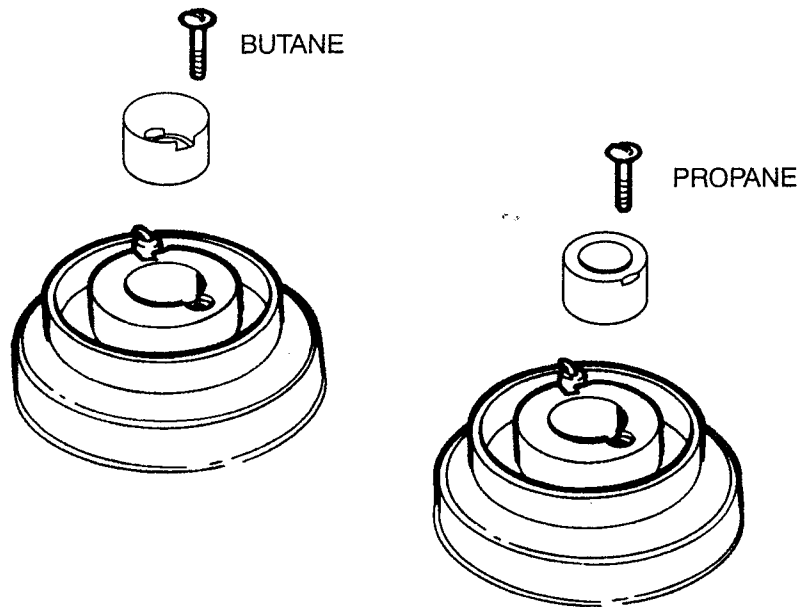

## AUTOMATIC COOKING

### AUTOMATIC COOKING

Only the main oven can be controlled automatically.

### GUIDANCE ON AUTOMATIC COOKING

1. When planning your meal remember that the oven control setting refers to the temperature on the middle shelf; above this shelf it is hotter and below it is cooler. Therefore foods which require different temperatures can be cooked automatically at the same time.
2. Set the oven timer so that the food has just finished or about to finish cooking on your return to the oven. This will ensure the food has not cooled down and does not require reheating before serving.
3. Food should be as cold as possible when it goes into the oven ideally straight from the refrigerator. Frozen meat and poultry should be thawed thoroughly before it is put in the oven.
4. We advise that warm food should never be placed in the oven if there is to be a delay period. Stews prepared by frying the meat and vegetables should be cooked as soon as possible.
5. We advise dishes containing left-over cooked poultry or meat, for example Shepherds Pie, should not be cooked automatically if there is to be a delay period.
6. Stews and joints should be cooked by the long slow method, so that the delay period is kept to a minimum.
7. On warm days, to prevent harmful bacterial growth in certain foods (ie poultry, joints, etc) the delayed start should be kept to a minimum.
8. Wine or beer may ferment and cream may curdle during the delay period, so it is best to add these ingredients just before serving.
9. Foods which discolour should be protected by coating in fat or tossing in water to which lemon juice has been added, prior to placing food in the oven.
10. Dishes containing liquid should not be filled too full to prevent boiling over.
11. Foods should be well sealed (but not airtight) in a container to prevent the loss of liquid during cooking. Aluminium foil gives a good seal.
12. Ensure food is cooked thoroughly before serving.

## ELECTRONIC CLOCK OPERATION

The oven timer offers you the following features:

1. Time of Day
2. Minute Timer
3. Automatic Cooking
4. Alarm (when set, this function produces an audible tone at the preselected time).

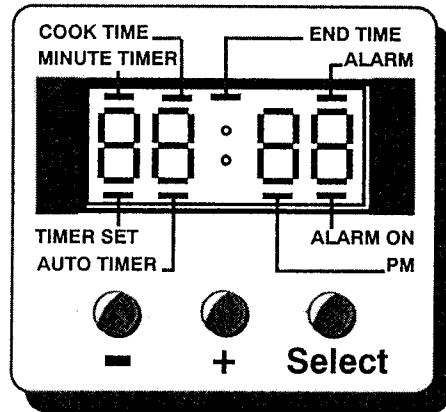

### GENERAL

The electronic clock has a four digit display with a central colon. Above this are four bars that light to indicate which function has been selected. Below are another four bars indicating which function of the timer has been set.

If any function other than the timer is set, the display will change back to time of day after a short period. Any times set may be reviewed by pressing the Select button until the relevant bar is lit.

### SETTING TIME OF DAY

1. Check that the electricity supply to the appliance is switched On.
2. It is possible to select either 12 hour or 24 hour clock operation i.e. 5.30 in the afternoon is displayed as 5:30 with the PM bar lit in the 12 hour mode or as 17:30 in the 24 hour mode.

When the appliance is switched on the display will show 24 Hr indicating that the timer is in the 24 hour clock mode. Press the - button to change to the 12 hour clock mode; the display will show 12 Hr. Pressing the + button will change the timer back to 24 hour clock operation.

3. Press the Select button once (the display will show 50H while the button is depressed); the display will show 12:00 (with the PM bar lit if the 12 hour clock has been chosen).

## INSTALLATION INSTRUCTIONS

### CONNECTING TO GAS SUPPLY

The cooker is designed to match the depth of standard 600mm worktops. An adaptor backplate should, therefore, be fitted within the shaded area shown to allow the cooker to be pushed fully to the wall. If a forward facing backplate is used, it must be chased into the wall.

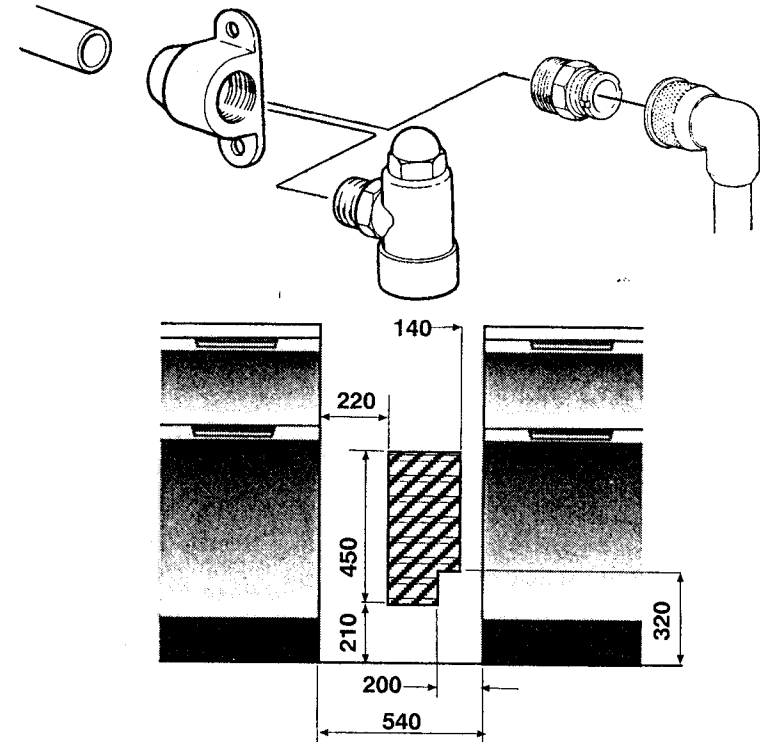

Connection to the cooker should be made with an approved appliance flexible connection to BS 669. LPG cookers should be connected with a hose suitable for L.P.G. and capable of withstanding 50mbars pressure. A length of 0.9 to 1.25m is recommended. The length of hose chosen should be such that when the cooker is in situ, the hose does not touch the floor.

The temperature rise of areas at the rear of the cooker that are likely to come in contact with the flexible hose do not exceed 70°C.

After installation, check for soundness.

The supply pressure can be checked at the grill injector. Access to the injector is by first removing the baffle at the front of the grill compartment fastened by two screws. Then remove burner fastening screw on right hand side of burner and slide burner off the injector. Ensure that the grill burner is correctly located under the screw head on reassembly.



## INSTALLATION INSTRUCTIONS

### UNPACKING THE COOKER

Unpack the components from inside the grill and oven: Check that the following parts are present.

Grill pan and grid	Top oven/grill shelf heat shield
Baking dish	Pan supports (4)
Baking tray	Enamelled discs (4)
Main oven shelves (3)	Burner port rings (4)
Top oven/grill shelf (1)	Literature

### LEVELLING

Two rear wheels and two front feet are fitted which can be adjusted up or down to level the cooker. The front feet can be screwed in or out and the rear wheels raised or lowered from the front of the cooker by adjusting the levelling screws "A" in the plinth.

**CAUTION:** Some soft floor coverings may get damaged if the cooker is not moved carefully.

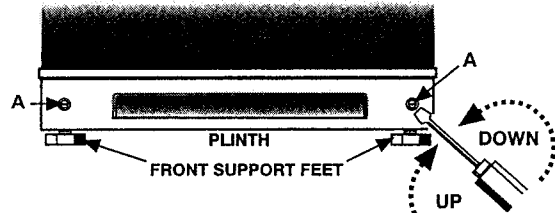

### STABILITY BRACKET

The cooker must be fitted with a stability device firmly secured to the fabric of the building. The back of the cooker has a slot for engagement of a stability bracket, which can be obtained, as an extra, from the cooker supplier. The leaflet included with the bracket should be read in conjunction with the following instructions.

Push cooker to its intended position.

Draw pencil lines on the floor in line with the front and left side of the plinth.

Remove the cooker.

Position stability bracket in accordance with diagram below and secure to the floor.

Measure height from floor level to the bottom of the slot in the back of the cooker.

Add 3mm to the dimension and assemble the stability bracket to that height. (i.e. from floor level to the underside of the top member).

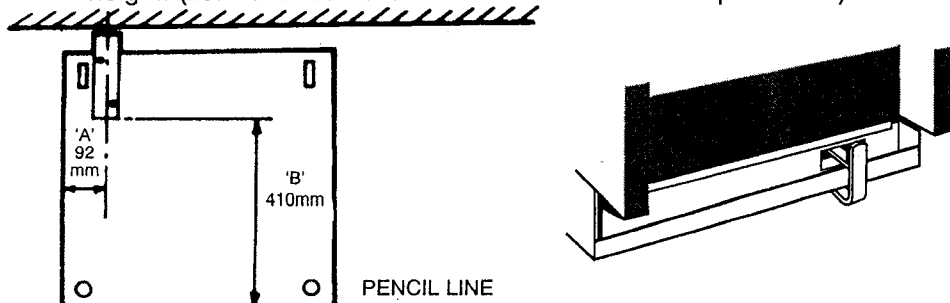

## ELECTRONIC CLOCK OPERATION

- Set the time of day using the + or – buttons.
- Once the correct time is set press the Select button to start the clock; the colon will begin to flash.
- If, when setting time of day, there is an interval of a minute or more when no button is pressed the display will revert to 24 Hr and the procedure will have to be started again.

### RE-SETTING TIME OF DAY

With the display showing time of day press and hold the – button for 5 seconds until the display changes to 00:00. On releasing the button 24 Hr will appear in the display and time of day can be set by following the procedure in the previous section.

### SETTING THE MINUTE TIMER

- Press the Select button once; the timer bar will light and the display will show 0:00.
- Set the time required using the + or – buttons up to a maximum of 23 hours 59 minutes; the timer set bar will light.
- During the timed period the display will show the time left to run (the final 55 seconds are counted down in seconds). If you require the time of day to be displayed press the Select button three times.
- At the end of the set time the display will show 0:00, a tone will sound and the timer set bar will flash. To cancel the tone, press any of the three buttons once. After a short period the display will return to time of day.
- The Minute timer may be cancelled at any time by pressing the + and – buttons together (the timed period must be displayed).

### USING THE MAIN OVEN AUTOMATICALLY

#### SWITCH 'ON' AND 'OFF' AUTOMATICALLY

- Make sure that the clock is showing the correct time of day. If not, follow the procedure in the section on resetting time of day.
- Press the Select button twice; the COOK TIME bar will light and the display will show 0:00.
- Press the + or – button to set the required cook time (i.e. the length of time that the food is to cook) up to a maximum of 23 hours 59 minutes; the AUTO SET bar will light.
- Press the Select button once more; the STOP TIME bar will light and the earliest time at which cooking can finish will be displayed. Use the + or – button to set the time at which you require cooking to finish (maximum 23 hours 59 minutes after current time of day).

## ELECTRONIC CLOCK OPERATION

5. Turn the main oven control knob to the required setting.
6. The timer will calculate the time at which cooking is to start and will turn the oven on automatically. When the cook time has elapsed the oven will switch off, a tone will sound and the AUTO SET bar will flash. To cancel the tone press any button once.
7. Turn the main oven control knob to the Off position and press the Select button once to return to manual operation.
8. To check the automatic settings, press the select button three times to view the cook time, and once more to view the stop time.

### TO SWITCH 'OFF' ONLY AUTOMATICALLY

1. Set the clock and cook time as 1, 2 and 3 above.
2. The cooking will start as soon as the main oven control knob is turned to the required setting. The oven will switch off automatically when the set cooktime has elapsed, a tone will sound. To cancel press any button.
3. Turn the oven control knob to the off position and press the Select button once to return to manual operation.

**NOTE:** To cancel an auto programme at any time, press the Select button until the COOK TIME or STOP TIME bar is lit then press the + and – buttons together.

### SETTING THE ALARM

1. Press the Select button three times; the ALARM bar will light and the display will show 0:00.
2. Use the + or – buttons to set the time at which the alarm is to sound; the ALARM ON bar will light.
3. When the time of day is the same as the alarm time which has been set a tone will sound and the ALARM ON bar will flash.
4. To cancel the alarm, press any button once.

## INSTALLATION INSTRUCTIONS

### SPACE FOR FIXING

The cooker can be close fitted below hotplate level. This requires a minimum distance of 540mm between cupboard units of hotplate height.

When installing next to a tall cupboard, partition or wall, for a minimum distance of 400mm above hotplate level, allow a side clearance of at least 65mm.

The diagram below illustrates the minimum clearance between the cooker and adjacent walls, cupboards etc.

The wall behind the cooker between the hotplate and 450mm above, and the width of the cooker, must be a non-combustible material such as ceramic wall tiles.

If the cooker is to be fitted close to a corner on the left hand side, ensure that there is a clearance of at least 50mm to allow the main oven door to open fully for when removing oven shelves.

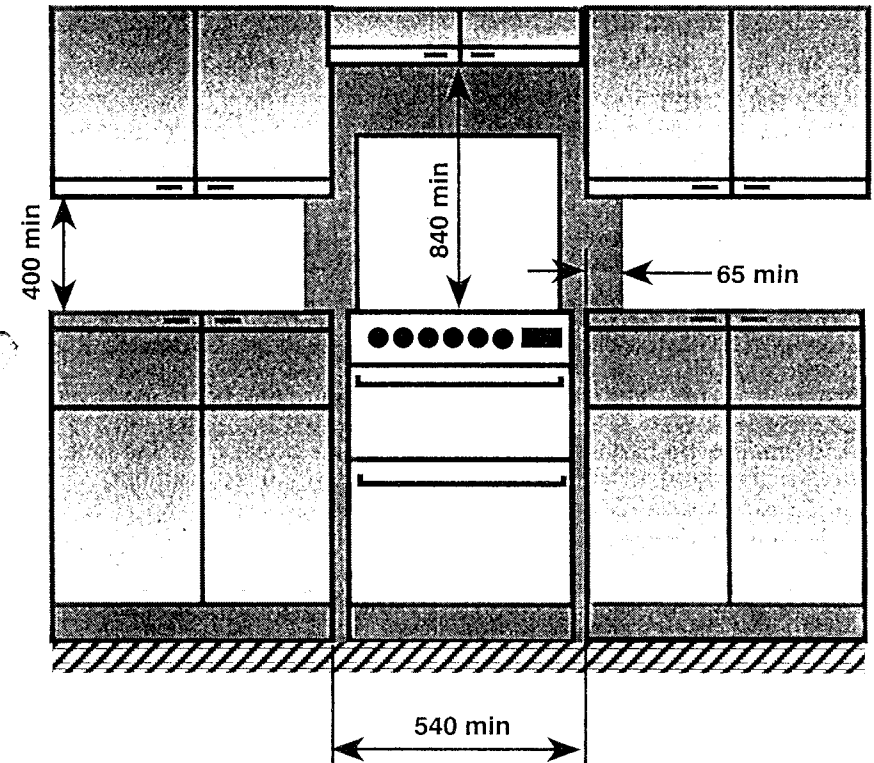

## TOP OVEN

The top oven can be used to cook small quantities of food or used in conjunction with the main oven to provide additional cooking space.

The shelf in the top oven has a heat shield fitted at the rear. The shield can be removed for cleaning but must be replaced when using the oven or grill. The shelf can be used in three different positions. It has a safety stop to prevent it from being pulled out too far when attending to food. The shelf is removed from the oven by pulling it out to the stop and then lifting at the front to withdraw.

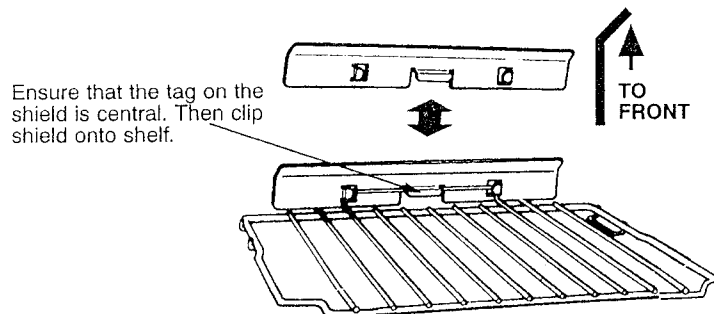

The baking dish, baking tray and grill pan without the handle can be used in the top oven. The size of the tray is the maximum that should be used, but two dishes e.g. casseroles, can be cooked side by side even if the space they occupy is larger than the tray.

### TO USE THE TOP OVEN

1. Check that the electricity is switched on.
2. Place the top oven shelf in the chosen position. (refer to cooking chart)
3. Push in and turn the top oven/grill control knob fully anti-clockwise. Sparking will continue until the burner has lit.
4. Turn the control knob clockwise to the required setting. (refer to cooking chart)  
There is a delay of about one minute whilst the safety device operates before the burner comes on full.
5. To turn off, turn the control knob clockwise to the symbol ●.

**NOTE: It is normal for a slight resistance to be felt when turning the control knob to the oven settings.**

### GUIDANCE ON USING THE TOP OVEN

1. Best results are obtained by pre-heating the oven for about 15 minutes.
2. The tray or dish on which the food is to be cooked, should be pushed to the back of the shelf.
3. Food which is higher than or will rise above 110mm (4 1/4") cannot be cooked in the top oven.

An odour may be noticed when first using the oven - this should cease after a short period of use.

Never place dishes on the oven base over the burner.

## INSTALLATION INSTRUCTIONS

**MODEL NOS. 10101G (BROWN), 10106G (WHITE), 10108G (GREEN).**

Gas Category: I<sub>2H</sub>.

These models are set to burn Natural gas, G20 at 20mbar only.

**MODEL NOS. 10102G (BROWN), 10107G (WHITE), 1019G (GREEN).**

Gas Category: I<sub>3</sub>.

These models are set to burn Butane gas, G30 at 28mbar. They can also be converted to burn Propane gas, G31 at 37mbar; only adjustment of the primary aeration of the hotplate burners is necessary. See page 30 for details.

### GAS SAFETY (INSTALLATION & USE) REGULATIONS

It is the law that all gas appliances are installed by competent persons in accordance with the current edition of the above regulations. It is in your interest and that of safety to ensure compliance with the law.

In the UK, CORGI registered installers work to safe standards of practice.

The cooker must also be installed in accordance with BS 6172: 1990.

Failure to install the cooker correctly could invalidate the warranty liability claims and could lead to prosecution.

### LOCATION

The cooker may be located in a kitchen, kitchen/diner or a bed-sitting room, but not in a room containing a bath or shower. The cooker must not be installed in a bed-sitting room of less than 20m<sup>3</sup>.

### PROVISION FOR VENTILATION

The room containing the cooker should have an air supply in accordance with BS 5440: Part 2: 1989.

The room must have an openable window or equivalent; some rooms may also require a permanent vent. If the room has a volume between 5 and 10m<sup>3</sup>, it will require an air vent of 50cm<sup>2</sup> effective area unless it has a door which opens directly to outside. If the room has a volume of less than 5m<sup>3</sup>, it will require an air vent of 100cm<sup>2</sup> effective area. If there are other fuel burning appliances in the same room, BS 5440: Part 2: 1989 should be consulted to determine air vent requirements.

# INSTALLATION INSTRUCTIONS

## TECHNICAL DATA

### DIMENSIONS

Height to hotplate	900 - 915mm
Width	538mm
Depth	600mm (excluding door handles)

### GENERAL

Countries of destination	GB, IE
Gas connection	Rp 1/2 (1/2" BSP female)
Electrical Connection	Flexible cord fitted with a 3 pin 13 amp plug 230/240V ac 50Hz 3A fuse

### HOTPLATE HEAT INPUTS/INJECTORS

Front left & rear right	3.0kW / 145
Front right & rear left	1.7kW / 105

### GRILL HEAT INPUTS/INJECTORS

Natural gas:	3.7kW / 150
LP gas:	3.2kW / 095

### OVEN HEAT INPUTS / INJECTORS

Top Oven	Natural gas: 2.7kW / 100
	LP gas: 2.4kW / 60

Main Oven	Natural gas: 2.7kW / 120
	LP gas: 2.4kW / 75



# HOTPLATE

The hotplate lid is fitted with a safety device which cuts off the gas supply to the hotplate burners unless the lid is fully open. Do not use the safety device as a means of controlling the hotplate burners.

The hotplate has two high speed burners and two simmering burners which will accommodate pans between 100mm (4") and 230mm (9") diameter. All pans should be positioned centrally over the burners.

Simmering aids such as steel plates should not be used because they can cause damage to the pan supports.

### TO USE THE HOTPLATE

1. Check that the electricity supply is switched on.
2. Push in and turn the control knob of the chosen burner anti-clockwise to the large flame symbol . Press the ignition button until the spark lights the gas.
3. Turn the control knob anti-clockwise to the desired setting. Only turn the control knob between the large flame symbol  and the small flame symbol  for adjusting the setting.
4. To turn off, turn the control knob fully clockwise.

**DO NOT** use mis-shapen pans which may be unstable.

**DO NOT** use round base woks directly on the pan supports.

**DO NOT** use the glass lid as a working surface.

### SAFETY REQUIREMENTS FOR DEEP FAT FRYING

1. Never fill chip pans more than one third full with oil or fat.
2. Never leave oil or fat unattended during the heating or cooling period.
3. Never heat fat or fry with a lid on the pan.
4. Always dry food thoroughly before frying, and lower it slowly into the hot oil or fat. Frozen foods in particular will cause frothing and spitting if added too quickly.
5. Always keep the outside of the pan clean and free from streaks of oil or fat.

### HOW TO DEAL WITH A FAT FIRE

1. Do not move the pan.
2. Turn off the hotplate burners.
3. Smother the flames with a fire blanket or damp cloth to extinguish the fire. Do not use water or a fire extinguisher as the force of it may spread the burning fat or oil over the edge of the pan.
4. Leave the pan for at least 60 minutes before moving it.

## CHECK POINTS

### IGNITION FAILURE

If all burners fail to ignite, check that sparks appear at the burners; a clicking noise should be heard. If not, and the timer and oven light are not working, there may be a fault with the electrical supply. Check that

- the wall socket is ok.
- the fuse is not blown. 3A fuse.

If only a hotplate burner is failing to light check that

- the burner cap and ring are seated correctly.
- the holes in the burner ring are not blocked.

If the electricity supply should fail, all burners apart from the lower oven can be lit with a match.

## SPARES & SERVICE

If there is still a problem with your cooker, contact your nearest service centre; refer to the Cannon Guarantee, Service and Spares Information Card for details.

Please have the following information available.

- Model/Number – Cannon Camberley  
Natural Gas: 10101G Brown/10106G White/  
10108G Green  
LPG: 10102G Brown/10107G White  
1019G Green

- Serial Number – For your convenience enter the cooker serial number in the box below:

The serial number is located behind the left-hand side of the main oven door seal.

Ensure that only authorised Cannon replacements are fitted to give the correct performance and appearance.

Repairs carried out by unauthorised or inexperienced persons may cause serious damage to the cooker, and may result in personal injury. Maintenance must be carried out by a competent person.

### DISPOSAL OF COOKER

To minimise the risk of injury to children, please dispose of your cooker safely. The mains cable should be cut off flush with the appliance and ensure that the mains plug can no longer be plugged into the mains socket.

## TOP OVEN COOKING CHART

The following times and setting are for guidance only. You may wish to alter the setting to give a result more to your satisfaction. When a different setting to that shown below is given in a recipe, the recipe instructions should be followed. Allow 15 minutes preheat for best results. Always turn the thermostat knob to Mark 8 before selecting the appropriate gas Mark. Shelf position 1 is the highest.

Food	Gas Mark	Shelf Position	Approx. Cooking Time and Comments
<b>FISH</b>			
		Push dish right to back of oven.	
Oily and white fish	5	2	20-30 mins.
<b>MEAT AND POULTRY</b>			
Beef (medium)	4 or 5	3	25-30 mins per lb + 25-30 mins
Ham (covered in foil)	5	3	40 mins per lb + 40 mins
Lamb	5	3	30-35 mins per lb + 30 mins
Pork	5	3	40 mins per lb + 40 mins
Chicken	5	3	25 mins per lb + 25 mins
Duckling & Goose	5	3	25 mins per lb + 25 mins
Turkey	4	3 or baseplate	15-20 mins per lb + 15-20 mins
Casseroles	3	3	2-4 hrs. depending on meat used.
<b>VEGETABLES</b>			
Baked jacket potatoes	5	2	1½ - 2 hrs.
<b>PUDDINGS</b>			
Milk Puddings (500ml/1pt)	3	2	1½ - 2 hrs.
Baked Custard (500ml/1pt)	3	2	45 mins - 1 hr. in bain-marie of cold water.
Baked Sponge Puddings	4	2	30 - 45 mins
Baked Apples	3	3	45 mins - 1 hr. depending on size
Meringue Topped Puddings	1	3	25 mins until tinged with brown
Apple Tart (1 x 205mm/8")	6	2	60 mins
Fruit Crumble	5	3	45 - 50 mins

If using aluminium foil:

1. Remember it is important to increase the cooking time by one third.
2. Do not allow the foil to touch the sides of the oven.
3. Do not cover the oven interior with foil.
4. Do not cover the oven shelves with foil.

## TOP OVEN COOKING CHART

Food	Gas Mark	Shelf Positions	Approx. Cooking Time and Comments
<b>CAKES, PASTRIES AND BISCUITS</b>			
Small Cakes (16 per tray)	5	2	20 - 25 mins.
Victoria sandwich (2 x 180mm / 7")	4	2	25 - 30 mins.
Swiss Roll (3 egg quantity)	6	2	10 - 12 mins.
Christmas cake (1 x 205mm / 8")	2	3	4 - 5 hrs depending on recipe
Madeira cake (1 x 180mm / 7")	4	3	1 hr.
Rich Fruit cake (1 x 180mm / 7")	2	2	2 1/4 - 2 1/2 hrs.
Gingerbread	3	2	1 1/2 - 1 3/4 hrs.
Scones - 16 per tray	7	2	12 - 15 mins.
Shortbread (1 x 180mm / 7")	2	2	45 mins. - 1 hr. depending on thickness
Biscuits	4-6	2	15 - 25 mins.
Shortcrust Pastry	6	2	15 mins. - 1 hr. depending on recipe
Rich Short Crust	5	2	20 - 30 mins.
Flaky/Puff Pastry	7	2	10 - 30 mins. depending on recipe
Choux Pastry	6	2	25 - 35 mins.
<b>YEAST MIXTURES</b>			
Bread - rolls, plait	7	2 or 3	25 - 35 mins
Tea breads etc.	5	2	25 - 30 mins
<b>MISCELLANEOUS</b>			
Yorkshire Pudding - small	7	2	20 - 25 mins
- large	7	2	30 - 40 mins
Meringues	1	3	2 1/2 - 4 hrs. turn when necessary

**Soft Margarine** – Use the oven settings recommended by the margarine manufacturer and **not** those indicated on the cooking chart.

## CARE AND CLEANING

### Glass

As for enamel cleaning. Polish with a clean dry cloth or kitchen roll.

### Chromium Plating

Oven shelves, grill pan grid, grill pan handle support

Wipe with a cloth wrung out in hot soapy water. A fine steel wool soap pad e.g. Brillo, Ajax, or a chrome or stainless steel cleaner may be used.

### Plastic

Grill pan handle, door handles, control knobs

Wipe with a cloth wrung out in hot soapy water. Stubborn stains can be removed with a cream cleaner.

### Control Knobs

If the control knobs are removed from the cooker for any reason care must be taken to ensure that they are refitted correctly.

The main oven control knob must have the rib on it's shaft aligned with the cut-out in the plastic housing behind the control panel.

If in doubt, contact your nearest service centre (see page 24 for details).

## CARE AND CLEANING

Switch off the electricity supply before cleaning the cooker.

Clean the cooker regularly and wipe up spills soon after they occur to prevent them from becoming burnt on. Never use biological washing powder, caustic cleaners, harsh abrasives, scouring pads, aerosol cleaners or oven chemical cleaners of any kind.

To move the cooker forward, open the top oven/grill door and with both hands positioned under the roof of the compartment lift and pull forward. Replace by pushing the cooker backwards. Check that the cooker is level. Take care to ensure that any floor covering is not damaged.

### MAIN OVEN HEAT CLEAN LININGS

The oven roof, back and side linings are coated with a special enamel which has a continuous cleaning action. The higher the oven temperature the more effective the action. In most cases this cleaning operation will proceed during normal cooking. However, if roasting is done frequently, or high temperatures are not used regularly, it may be necessary to run the oven empty at Mark 8 for about two hours.

If desired, they can be wiped with a cloth wrung out in hot soapy water followed by a clean damp cloth.

### MAIN OVEN DOOR

The inner glass panel can be removed for easy cleaning. Unscrew the two screws securing the glass panel, taking care not to allow the glass to fall. The glass panel can then be washed at the sink. Refit the glass panel according to the instruction on it. **Warning:** The oven must not be operated with the inner glass panel removed.

### COOKER FINISH

#### Vitreous Enamel

Hotplate, control fascia, pan supports, burner ring discs, roasting dish, baking tray, grill pan, oven base, inside of oven and grill door, grill compartment.

#### Paint & Anodised Aluminium

Side trims, plinth, lid trim, door bottom trims, fascia trim, hotplate side trims

#### Aluminium

Burner port rings, burner bodies.

### CLEANING METHOD

Cloth wrung out in hot soapy water.

Stubborn stains can be removed with a cream, paste, liquid cleaner or by rubbing with fine steel wool soap pads.

Check that the cleaning agent is approved by the Vitreous Enamel Development Council.

Wash with a cloth wrung out in hot soapy water only.

**DO NOT USE ABRASIVES.**

Similar to paint cleaning above.

Use a nylon brush to remove any cleaning materials, water or dirt from the burner port rings.

## GRILL



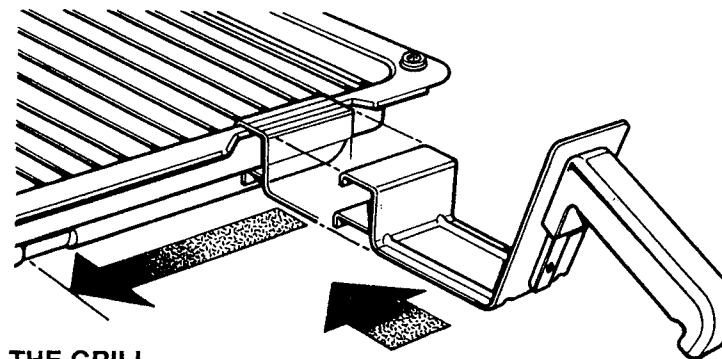

**CAUTION – ACCESSIBLE PARTS MAY BECOME HOT WHEN THE GRILL IS USED. YOUNG CHILDREN SHOULD BE KEPT AWAY.**

### GRILL PAN HANDLE

To attach the handle, hook it on to the side of the pan at the cut out edge. Slide it to the left along the pan to the indentation. Check that the handle is fitted properly before using the pan. The grill pan can be stored in the grill compartment if the handle is removed.



### TO USE THE GRILL

1. Check that the electricity supply is switched on.
2. Open the top oven/grill door and remove the grill pan.
3. Place shelf in chosen position.
4. Push in and turn the control knob clockwise to the large flame symbol . Press the ignition button until the spark lights the gas.
5. Turn the control knob clockwise to the desired setting. Only turn the control knob between the large flame symbol  and the small flame symbol  when adjusting the setting.
6. To turn off, turn the control knob anti-clockwise to the symbol .

Slide the grill pan along the shelf towards the rear of the grill compartment until it touches the stops.

The grill cannot be used at the same time as the top oven.

An odour may be noticed when first using the grill – this should cease after a short period of use.

**DO NOT** use the grill with the door closed.

**DO NOT** cover the grill pan or grid with aluminium foil as this can hold fat, intensify the heat and create a fire hazard.

## GRILL

The following chart is a guide. Grilling can be started from cold but for best results preheat for approximately two minutes. Most cooking is done with the heat full on but it may be desirable to reduce it for thicker pieces of meat or for keeping food warm.

Shelf Position	Food
HIGH POSITION	Toast, pikelets/crumpets, bacon, thin sausages, beefburgers, tomato halves, steak (rare and medium), kippers, gammon, kidneys and toasted snacks.
CENTRE POSITION	Toast, toasted snacks, thick sausages, beefburgers, fish fingers, steak (well done), gammon, chops (with heat turned down for part of cooking time).
LOWEST POSITION	Whole fish, fish fillets and fish steaks. Chicken portions (with heat turned down for part of cooking time).

For au gratin dishes eg. Macaroni Cheese and meringue toppings eg. Baked Alaska, place the dish on the floor of the grill compartment. The base of the grill pan can be used for warming fruit garnishes on the reduced setting.

**NOTE:** Strong detergents used in dishwashers may damage the grill pan grid finish; clean in soapy water as described in CARE AND CLEANING section.

Always ensure that the grill pan handle is correctly fitted to the grill pan. If necessary tighten any loose screws with a screwdriver.

## MAIN OVEN COOKING CHART

Food	Gas Mark	Shelf Positions	Approx. Cooking Time and Comments
<b>CAKES, PASTRIES AND BISCUITS</b>			
Small cakes - 2 trays	5	2 & 4	17 - 25 mins
- 1 tray	5	2 or 3 only	"
Victoria sandwich 2x8" (205mm)	4	2 & 4	25 - 35 mins
Fatless sponge 2x7" (180mm) - 3 egg mix	5	2	20 - 25 mins. 2 tins side by side
Christmas cake	2	3 or 4	4 - 6½ hrs depending on recipe
Leira cake 7" (180mm)	4	3	1¼ - 1½ hrs
Rich Fruit cake 9" (230mm)	2	3	3 - 3½ hrs.
Shortcrust pastry	6	2 or 3	15 mins - 1 hr depending on recipe
Rich Shortcrust pastry - 1 tray	5	2	20 - 40 mins depending on recipe.
Flaky & puff pastry - 2 trays	7	1 & 3	10 - 30 mins depending on recipe
- 1 tray		2 or 3	" " " "
Choux pastry - éclairs 1 tray	6	2	35 - 40 mins
Scones - 2 trays	7	2 & 4	10 - 15 mins
- 1 tray		2 or 3	"
Shortbread - 7" (180mm) round	2	4	55 - 1hr depending on thickness
Biscuits - 2 trays	4	1 and 3	15 - 20 mins depending on recipe
- 1 tray		2 or 3	" " " "
<b>YEAST MIXTURES</b>			
Bread	7 or 8	3 or 4	45 - 50 mins
Buns	7 or 8	2 or 3	15 - 20 mins
Chelsea buns	5	2 or 3	30 - 40 mins
<b>MISCELLANEOUS</b>			
Yorkshire Pudding - large	7	1 or 2	45 - 50 mins
- individual	7	1 or 2	25 - 30 mins
Soufflés	4	3	30 mins
Meringues	'E'	4 & baseplate	2 - 5 hrs starting on shelf 4 until 'set' and then on the baseplate until dried out - turn when necessary.
Baked Potatoes	4 or 5	3	1½ - 3 hrs until soft, depending on size

When baking with two trays or tins on two levels, the top tray is removed first and the lower tray moved up to the top position for a few minutes longer.

**Soft Margarine** - Use the oven settings recommended by the margarine manufacturer and **not** those indicated on the cooking chart.



## MAIN OVEN

### THE 'E' SETTING

This is used for slow cooking, keeping food warm and warming plates for short periods.

### USING THE 'E' SETTING FOR SLOW COOKING

1. All dishes cooked by the 'E' setting should be cooked for a minimum of 6 hours. They will 'hold' at this setting for a further hour but marked deterioration in appearance will be noticed in some cases.
2. Joints of meat and poultry should be cooked at Mk 6 for 30 minutes before turning to the 'E' setting and never be cooked lower than the middle shelf position.
3. Joints of meat over 6 lbs (2.7kg) and poultry over 4 lbs 8oz (2kg) should not be cooked using the 'E' setting.
4. Always stand covered joints on a rack over the meat tin to allow good air circulation.
5. Pork joints and poultry must be checked for an internal temperature of at least 88°C using a meat thermometer.
6. This method is unsuitable for stuffed meat and poultry.
7. Always bring soups, casseroles and liquids to the boil before putting in the oven.
8. Cover casseroles with foil and then the lid to prevent loss of moisture.
9. Always thaw frozen food completely before cooking.
10. Root vegetables will cook better if cut into small pieces.
11. Adjust seasonings and thickenings at the end of the cooking time.
12. Use the zones of heat in the oven, e.g. meringues and milk puddings can be cooked lower in the oven whilst other dishes requiring greater heat can be cooked above them.
13. Egg and fish dishes need only 1-5 hours cooking and should be included in day cooking sessions, when they can be observed from time to time.
14. Dried red kidney beans must be boiled for a minimum of ten minutes after soaking, before inclusion in any dish.

### REPLACEMENT OF OVEN LIGHT BULB

Light bulbs are not covered by the manufacturer's guarantee.

A new 25W, 300°C rated SES bulb can be obtained from your cooker supplier or any major electrical retailer.

1. Disconnect the electricity supply to the cooker and remove the shelves from the oven.
2. Unscrew the lens using a thick cloth to your protect fingers in the unlikely event of a lens fracture.
3. Unscrew bulb.
4. Fit new bulb and refit lens.

## STORAGE & REHEATING OF FOOD

### STORAGE AND RE-HEATING OF FOOD

It is vitally important to strictly adhere to the basic principles of food handling and hygiene to prevent the possibility of bacterial growth.

1. If food is to be frozen or not served immediately, cool it in a clean container as quickly as possible.
2. Completely thaw frozen food in the refrigerator before re-heating.
3. Re-heat food thoroughly and quickly either on the hotplate or in a hot oven, mk 6, and then serve immediately.
4. Only re-heat food once.

### 'COOK CHILL' DISHES

These should always be placed in a pre-heated oven ideally on the first or second shelf position. Follow the packet instructions for cooking time.

## MAIN OVEN COOKING CHART

The following times and setting are for guidance only. You may wish to alter the setting to give a result more to your satisfaction. When a different setting to that shown below is given in a recipe, the recipe instructions should be followed. Allow 15 minutes preheat for best results. Always turn the thermostat knob to Mark 9 before selecting the appropriate Gas Mark. Shelf position 1 is the highest.

Food	Gas Mark	Shelf Positions	Approx. Cooking Time and Comments
<b>STARTERS</b>			
Patés and Terrines	3 or 4	4	1½ - 2 hrs
<b>FISH</b>			
Oily Fish (whole)	4 or 5	3	25 mins - 1 hr, depending on recipe and size of fish
White Fish (fillets & steaks)	4 or 5	3	25 - 30 mins.
<b>MEAT AND POULTRY</b>			
Veal	5	4	25 mins per lb + 25 mins
Beef	4 or 5	4	25 - 30 mins per lb + 25 mins
Ham	5	4	40 mins per lb covered in foil + 40 mins per lb uncovered
Lamb	5	4	30 - 35 mins per lb + 30 mins
Pork	5	4	40 mins per lb + 40 mins
Chicken	5	4	25 mins per lb + 25 mins
Duckling & gosling	5	4	25 mins per lb + 25 mins
Turkey	4 or 5	4 or 5	15 - 20 mins per lb + 20 mins
Game birds	6	4	50 mins. Remove bacon for last 15 mins. Add extra 15 mins if roasting brace
Casseroles	3	3 or 4	1½ - 6 hrs. (depending on type of meat)
<b>PUDDINGS</b>			
Milk Puddings	3	3 or 4	2¼ - 2½ hrs on a baking tray and started with warm milk
Baked Custard	3	3 or 4	45 mins in bain-marie
Baked sponges	4	3	40 - 50 mins
Baked Apples	3	4	30 - 45 mins depending on the size and type of apples
Meringue puddings	1	4 or 5	15 mins or until 'tinged' with brown
Apple Pie 1x9" (230mm)	6	3	45 - 55 mins on a baking tray
Fruit crumbles	5 or 6	3	35 - 45 mins

If using aluminium foil:

1. Remember it is important to increase the cooking time by one third.
2. Never allow the foil to touch the sides of the oven.
3. Never cover the oven interior with foil.
4. Never cover the oven shelves with foil.

## MAIN OVEN

The oven has different heat zones – the thermostat settings refer to the temperature on the middle shelf; above this shelf it is hotter and below it is cooler. Two straight shelves and one cranked shelf provide ten possible cooking levels enabling full use of the different temperatures inside the oven.

Each shelf has a safety stop to prevent it from being pulled out too far when attending to food. Shelves are removed from the oven by pulling them out to the stop and then lifting them at the front to withdraw.

The baking dish, baking tray and grill pan without the handle can be used in the main oven. The size of the tray is the maximum that should be used, but two dishes e.g. casseroles, can be cooked side by side even if the space they occupy is larger than the tray.

### TO USE THE MAIN OVEN

1. Check that the electricity supply is switched on and the timer is set to manual mode.
2. Place oven shelves in the chosen positions (refer to cooking charts).
3. Push in and turn the oven control knob fully anti-clockwise. Sparking will continue until the burner is lit.
4. Turn the control knob clockwise to the required setting (refer to cooking chart). There is a delay of about one minute whilst the safety device operates before the burner comes on full.
5. To turn off, turn the control knob fully clockwise to the symbol ●.

Never place dishes on the oven base over the burner.

An odour may be noticed when first using the oven – this should cease after a short period of use.

### COLD START COOKING

Anything requiring long slow cooking such as casseroles and rich fruit cakes can be put into a cold oven. Satisfactory results can also be obtained with creamed mixture, rich pastries or yeast mixtures, but for perfection we recommend pre-heating the oven for about 15 minutes.

### ROASTING OF LARGE POULTRY

The maximum weight of turkey that can be accommodated is 25lbs (11.5kg) provided it is of suitable shape.

It is important to check that the bird DOES NOT overhang the burner at the back of the oven.