

Cascade systems Quinta Pro

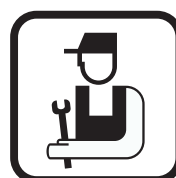

Cascade guide

Contents

1	Introduction	4
	1.1 General	4
2	General description of cascade systems	5
	2.1 The optimum number of boilers in a cascade	5
	2.2 Compact cascade configurations	6
	2.3 Cascade systems	6
	2.4 Hydraulic isolation: low loss header	6
	2.5 Output control	6
3	Remeha cascade systems	7
	3.1 General	7
	3.2 Structure of cascade systems	7
4	Cascade system components	9
	4.1 General	9
	4.2 Main pipes	9
	4.3 Low loss header	10
	4.4 Boiler pump	10
	4.5 Boiler connection kits	10
	4.5.1 Connection kit with pump	11
	4.6 Free-standing frames	11
	4.7 Accessories	11
	4.8 Installation area and dimensions	12
5	Installation drawings for cascade systems	13
	5.1 General	13
	5.2 Wall-mounted linear configuration - LW	14
	5.2.1 Installation drawing with 2 boilers - LW	14
	5.2.2 Installation drawing with 3 boilers - LW	15
	5.2.3 Installation drawing with 4 boilers - LW	16
	5.2.4 Installation drawing with 5 boilers - LW	17

	5.2.5	Installation drawing with 6 boilers - LW	18
5.3		Free-standing linear configuration - LV	19
	5.3.1	Installation drawing with 2 boilers - LV	19
	5.3.2	Installation drawing with 3 boilers - LV	20
	5.3.3	Installation drawing with 4 boilers - LV	21
	5.3.4	Installation drawing with 5 boilers - LV	22
	5.3.5	Installation drawing with 6 boilers - LV	23
5.4		Back-to-back configuration - RG	24
	5.4.1	Installation drawing with 3 boilers - RG	24
	5.4.2	Installation drawing with 4 boilers - RG	25
	5.4.3	Installation drawing with 5 boilers - RG	26
	5.4.4	Installation drawing with 6 boilers - RG	27
6		Independently installed cascade systems	28
	6.1	General	28
	6.2	Standard cascade system	29
	6.3	Dimensioning a standard low loss header	30
	6.4	DUO and TRIO low loss headers	31
	6.5	Boiler and system pumps	31
	6.6	Non-return valve	33
	6.7	Overflow valve and manual seals	33
	6.8	Expansion vessel	33
	6.9	Configuration and mounting	33
7		Gas connection	34
	7.1	General	34
	7.2	Gas pressures	34
8		Connections for the air and exhaust pipes	35
	8.1	General	35
	8.2	Individual flue gas discharge	35
	8.3	Joint flue gas discharge	35
	8.4	Material requirements	36
	8.5	Condensate drain	36
9		Exploded view	38
	9.1	Exploded view	38

1 Introduction

1.1 General

This technical information contains useful and important information for proper dimensioning of a cascade system with wall-mounted boilers. It describes the correct use of the complete Remeha cascade systems with the modulating wall-mounted boilers Quinta Pro 30/45/65/90/115.



Please contact us if you have any questions or for further information about cascade configurations.

2 General description of cascade systems

2.1 The optimum number of boilers in a cascade

In many situations it is advantageous to spread the total required heat output over several boilers. This can be made possible by means of a "cascade system". In a cascade configuration, heating boilers are connected hydraulically. If the heat demand increases or decreases, boilers are switched on or off respectively. If using a Remeha multiple boiler controller or a quality building management system. It is then important to determine the ideal number of boilers for the cascade. The following factors need to be taken into account when deciding on the number of boilers:

▶ **Investment:**

When boilers are split up, the investment costs (boiler cost including installation, fittings, pipe work, pumps and control equipment) can work out lower or higher. However, this depends to a large extent on the situation.

▶ **Reliability:**

Reliability increases with the number of boilers. Research has shown that reliability is already optimum for systems with four boilers in a cascade.

▶ **Efficiency:**

There is no appreciable difference in terms of efficiency between several small or one or two larger boilers.

▶ **Maintenance and faults:**

There is a greater overall risk of faults in a system with several boilers. A larger group of engineers can service and maintain smaller boilers.

▶ **Configuration:**

The lightweight and compact design means that you have more flexibility when siting the boilers. Very little floor space is required and there is minimum load on the floor.

▶ **Adjustment:**

When using several boilers and modulating control, the heat output offered is virtually equal to the heat output requested.



A number of the points mentioned are dependent on the situation and so consideration as to which solution is the best will need to be given on a project-by-project basis.



The cascade kits are not supplied with the boilers they must be ordered separately.

2.2 Compact cascade configurations

The boilers Quinta Pro 30/45/65/90/115 are particularly suitable for use in a cascade configuration. Their width of only 50 cm means that a high heat output level can be installed on a small wall. This big difference becomes apparent when comparing a Remeha cascade system with cascade systems using boilers from other manufacturers.



For example, using 6 times a Quinta Pro 115, only approx. 3.8 m (including low loss header) wall width is required for 642 (80/60°C) kW. The boilers therefore allow an exceptionally compact cascade configuration.

2.3 Cascade systems

For installing 2 to 6 boilers, our product range includes systems that are very comprehensive and easy to install. The hydraulic and gas system can be put together entirely without welding, using screw connections, compression connections and flanges. The individual components of the cascade systems are available for independent cascade installation.

2.4 Hydraulic isolation: low loss header

Practical experience has shown that it is beneficial to create hydraulic isolation between the boiler circuit and the system circuit using a low loss header. This means that a widely varying volume flow on the system side hardly influences the volume flow on the boiler side at all. This also applies in reverse: a widely varying volume flow on the boiler side hardly influences the volume flow on the system side at all. Controlling several different groups hydraulically is therefore significantly easier as they do not, or barely, influence each other. This creates better overall operating conditions for the system.

2.5 Output control

Use the iSense Pro for up to 6 boilers or the iSense in combination with the Celcia MC4 for a maximum of 4 boilers.

3 Remeha cascade systems

3.1 General

In order to make it as simple as possible to create a cascade configuration, our product range has included complete cascade systems for years. The compact design of the boilers, combined with the smart gas and water connection technology of the cascade system, makes it possible to install a high heat output in a small area. For example, using six Quinta Pro 115 boilers, only 3.8 m approx. (including low loss header) wall width is required for 642 kW (60/80°C). The cascade systems can be divided into 3 main groups:

- ▶ 2 to 6 boilers in a linear configuration, wall mounted.
- ▶ 2 to 6 boilers in a linear configuration, mounted on a free-standing frame.
- ▶ 3 to 6 boilers in a back-to-back configuration, mounted on a free-standing frame.



Please contact us for different configurations (specials). We also provide in-depth advice on the choice of flue gas discharge material and control engineering, including for non-standard configurations.

3.2 Structure of cascade systems

The return, flow, and gas connections of the individual boilers are connected using the fittings supplied by means of horizontal connections to main pipes for return, flow and gas. These pipes are welded onto a frame that rests on the floor and is fixed to the wall or to a free-standing frame.

The low loss header supplied has flange connections, which can be fitted to the left or right of the cascade main pipe as required. The blind flanges supplied are then fitted on the other side. The gas main pipe has a flange to which the optional gas filter can also be connected on the left or right as required. The blind flange supplied is then fitted on the other side. When a gas filter is used, a pressure loss of 3 mbar over the gas filter must be taken into account. The minimum inlet working gas pressure after the gas filter is 17 mbar. A common PVC condensed water discharge pipe (not supplied) can be installed in the frame. For this purpose, holes have been made in the frame into which this pipe can be fitted (to the left or right as required) sloping downwards.



Any combination of boilers is possible. See the table for the corresponding heat outputs.

Boiler type	Useful output [kW]	
	50/30 °C	80/60 °C
Quinta Pro 30	31.4	29.3
Quinta Pro 45	43.0	40.0
Quinta Pro 65	65.0	61.0
Quinta Pro 90	89.5	84.2
Quinta Pro 115	114.0	107.0

4 Cascade system components

4.1 General

The cascade systems consist of the following components:

- ▶ Main pipes.
- ▶ Low loss header.
- ▶ Boiler pump.
- ▶ Boiler connection kits.
- ▶ Free-standing frames.
- ▶ Accessories.

4.2 Main pipes

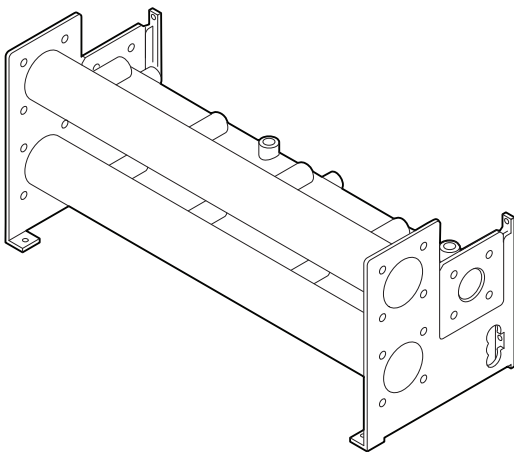

T003254-B

The main pipes consist of: main flow, return and gas pipe with wall bracket for all boilers. The cascade systems consist of the following components. By connecting main pipes, it is possible to extend the system to a maximum of 6 boilers in a linear configuration or 2 x 3 boilers in a back-to-back configuration. In a linear configuration, the rear connections must be capped off using the caps supplied. In a back-to-back configuration with an odd number of boilers, the unused connections must also be capped off.

Diameter flow and return pipe 65 mm:

- ▶ Main pipes for 2 boilers with gas pipe DN 50
- ▶ Main pipes for 3 boilers with gas pipe DN 50
- ▶ Main pipes for 4 boilers with gas pipe DN 50

Diameter flow and return pipe 100 mm:

- ▶ Main pipes for 2 boilers with gas pipe DN 65
- ▶ Main pipes for 3 boilers with gas pipe DN 65
- ▶ Main pipes for 4 boilers with gas pipe DN 65

4.3 Low loss header

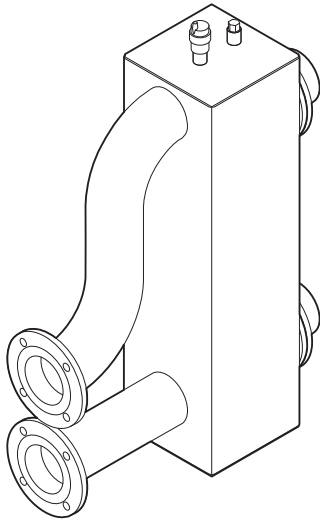

T003256-B

The low loss headers have the following connecting flanges:

- ▶ Low loss header for main pipes with diameter = 65 mm up to a heat output of 460 kW. Boiler-side connection: DN 65 (PN6, DIN 2631; 4 holes). System-side connection: DN 100 (PN6, DIN 2631; 8 holes).
- ▶ Low loss header for main pipes with diameter = 100 mm up to a heat output of 642 kW. Boiler-side connection: DN 100 (PN6, DIN 2631; 4 holes). System-side connection: DN 125 (PN6, DIN 2631; 8 holes).



The low loss header is supplied with a manual air vent as standard.

4.4 Boiler pump

The cascade sets are supplied complete with pump for each Quinta Pro. Designed for a nominal flow rate based on a design condition of 20°C on the boiler primary side of the header.



The boiler connection kits include the required glands.



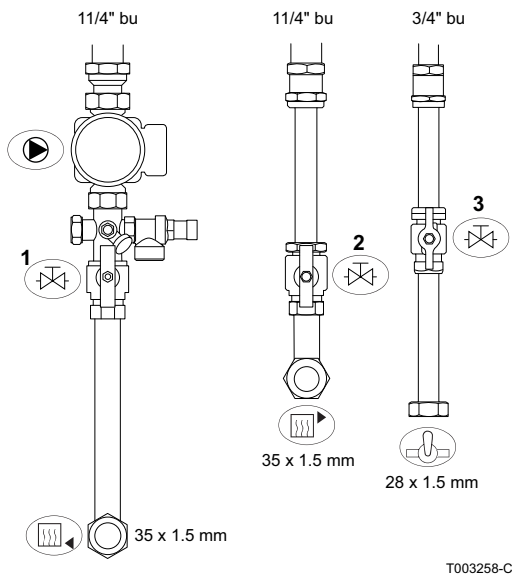

4.5 Boiler connection kits

The boiler connection kit consists of service shut-off valves in the flow, return and gas pipes and also include the pipes between boiler and main pipes. In a back-to-back configuration, the length of the pipes that go to the rearmost row of boilers has been adjusted to the correct length. It is assumed that, when an odd number of boilers are supplied, the larger number of boilers is mounted on the front. The service shut-off valve in the return includes safety valve, non-return valve, filling and drain cock and expansion vessel connection. The return valve has a T piece for additional connections (for example an expansion vessel or calorifier).

4.5.1. Connection kit with pump



T003258-C

-  Flow connection:
(1 1/4" female thread to boiler and 35 x 1,5 mm to main pipe):
-  Return connection:
(1 1/4" female thread to boiler and 35 x 1,5 mm to main pipe)
-  Gas connection:
(3/4" female thread to boiler and 28 x 1,5 mm to main pipe)
-  Boiler pump
- 1** Ball valve, overflow, non-return valve, expansion vessel connection (3/4" male thread) and filling/drain cock in return pipe
- 2** Ball valve in flow pipe
- 3** Gas cock

4.6 Free-standing frames

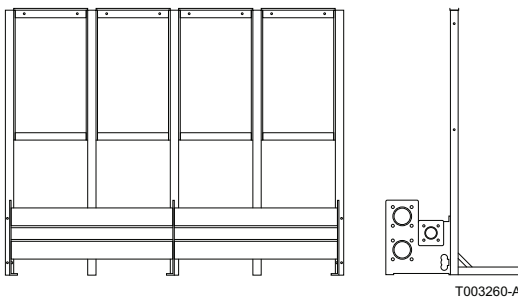

T003260-A

The free-standing frames consist of a combination of I and/or L poles with an intermediate frame. 1 intermediate frame is required per boiler. The L poles have bolt holes for fixing to the floor. The frame is equipped with a fitting bracket. L poles are only required if boilers are mounted at the rear of the frame (for a back-to-back configuration). Only I poles are used with linear configurations. The top of the frame can be used as a cableway. The nuts and bolts required are included with the delivery, along with installation instructions. Fastenings for fixing to the floor are not included.

4.7 Accessories

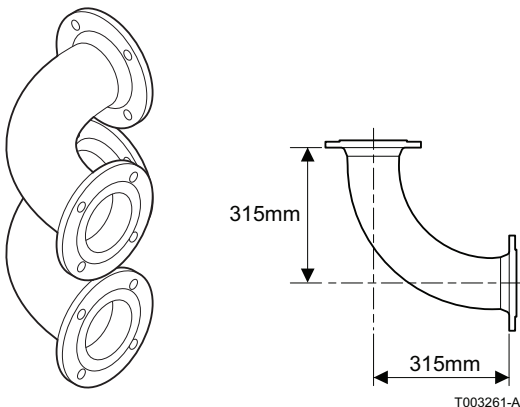

T003261-A

- ▶ Elbow kit for angled connection of the low loss header in 65 and 100 mm diameters.
- ▶ Connecting flanges for system side of the low loss header.



Depending on the system resistance, it may be necessary to switch to a larger pipe diameter after the connecting flanges of the low loss header.

- ▶ Modulating weather compensator *1.
- ▶ Modulating controller Celcia MC4 (always with a iSense controller).
- ▶ Frame fixing plate for iSense Pro and Celcia MC4.
- ▶ Insulation for low loss header, low loss header elbow, connection kits and main pipes.
- ▶ Gas filters DN 50 and DN 65.

- ▶ Gas filter extension piece (for fitting gas filter next to low loss header) DN 50 and DN 65 (To be used when gas filter is fitted on the same side as the low loss header + elbows or low loss header + insulation).
- ▶ Adjustable legs.

4.8 Installation area and dimensions

Select the desired combination of boilers on the basis of the required heat output. We recommend a clearance of 1 m (at least 60 cm) in front of the units. The distance between the boilers is 3 cm. A wall bracket is supplied for wall-mounted linear configuration. This must be mounted at a height as specified in the installation manual supplied with the cascade system. We recommend a clearance of at least 40 cm above the units. This distance also depends on any installation of flue gas discharge and air supply collector pipes.

5 Installation drawings for cascade systems

5.1 General

The cascade systems can be divided into 3 main groups:

- ▶ 2 to 6 boilers in a linear configuration, wall mounted.
- ▶ 2 to 6 boilers in a linear configuration, mounted on a free-standing frame.
- ▶ 3 to 6 boilers in a back-to-back configuration, mounted on a free-standing frame.





The boiler side of the cascade systems is sized to $20\Delta T$.
The low loss header is based on $20 / 11\Delta T$.

5.2 Wall-mounted linear configuration - LW

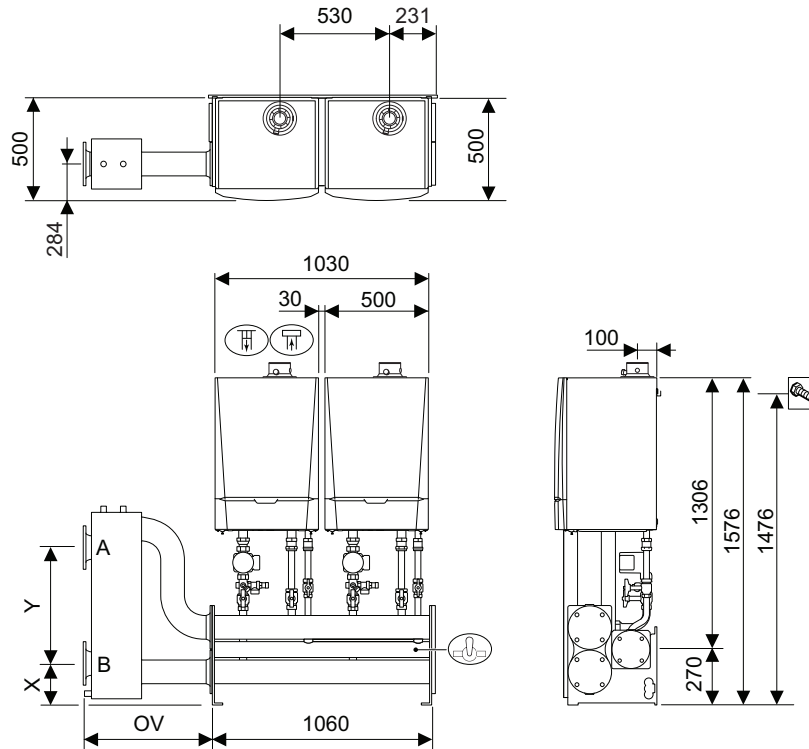
5.2.1. Installation drawing with 2 boilers - LW





T003410-A

- A** System flow; connection DN 100 / DIN 2631 (8 holes)
- B** System return; connection DN 100 / DIN 2631 (8 holes)
-  Gas supply connection DN 50 / DIN 2633 (4 holes)
-  Air inlet / Flue gas discharge concentric connection
Quinta Pro 30/45 = 80 / 125 mm, Quinta Pro 65/90/115 = 100 / 150 mm
-  Suspension points
- OV** Low loss header ; DN 65 = 633 mm DN 100 = 643 mm
- X** Distance to system return connection = 200 mm
- Y** Distance to system flow connection = 560 mm

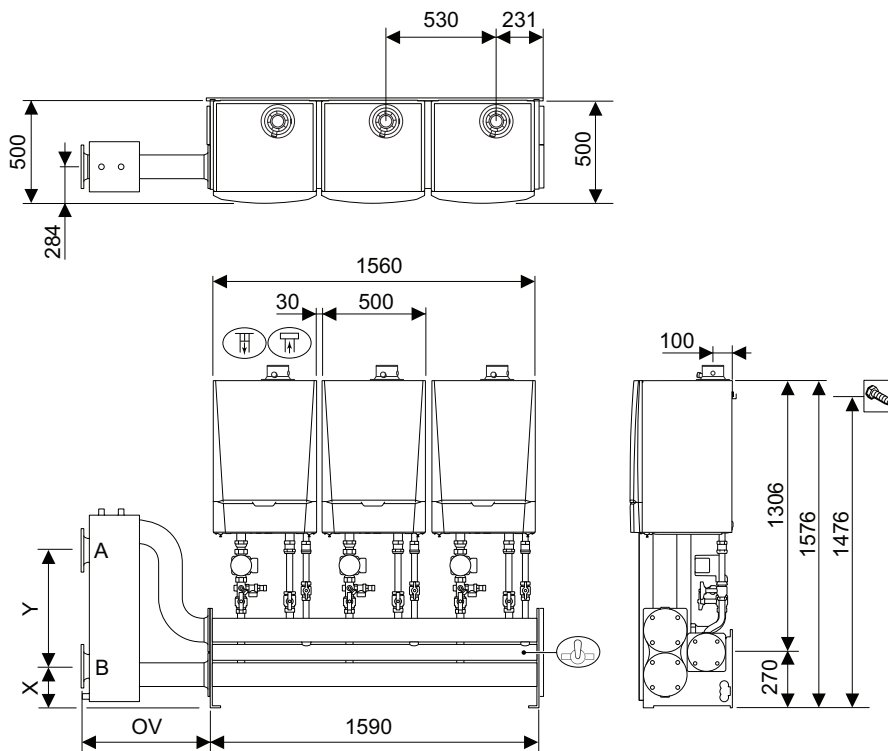
5.2.2. Installation drawing with 3 boilers - LW





T003411-A

- A** System flow; connection DN 100 / DIN 2631 (8 holes)
- B** System return; connection DN 100 / DIN 2631 (8 holes)
-  Gas supply connection DN 50 / DIN 2633 (4 holes)
-  Air inlet / Flue gas discharge concentric connection
Quinta Pro 30/45 = 80 / 125 mm, Quinta Pro 65/90/115 = 100 / 150 mm
-  Suspension points
- OV** Low loss header ; DN 65 = 633 mm DN 100 = 643 mm
- X** Distance to system return connection = 200 mm
- Y** Distance to system flow connection = 560 mm

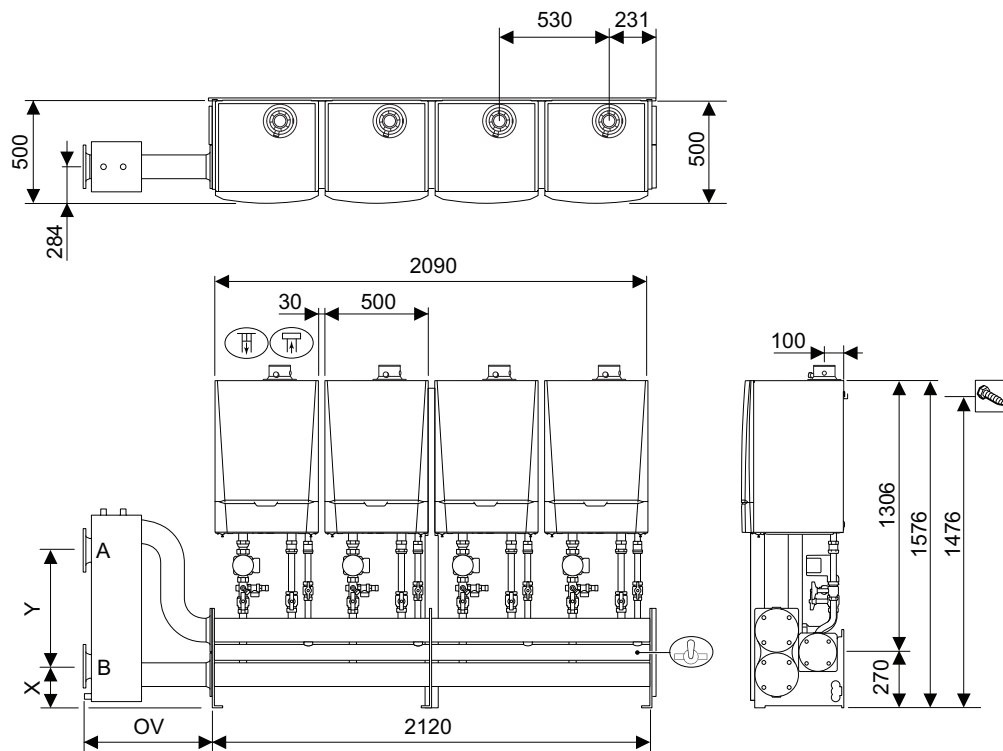
5.2.3. Installation drawing with 4 boilers - LW





T003412-A

- A** System flow; connection DN 100 / DIN 2631 (8 holes)
- B** System return; connection DN 100 / DIN 2631 (8 holes)
-  Gas supply connection DN 50 / DIN 2633 (4 holes)
-  Air inlet / Flue gas discharge concentric connection
Quinta Pro 30/45 = 80 / 125 mm, Quinta Pro 65/90/115 = 100 / 150 mm
-  Suspension points
- OV** Low loss header ; DN 65 = 633 mm DN 100 = 643 mm
- X** Distance to system return connection = 200 mm
- Y** Distance to system flow connection = 560 mm

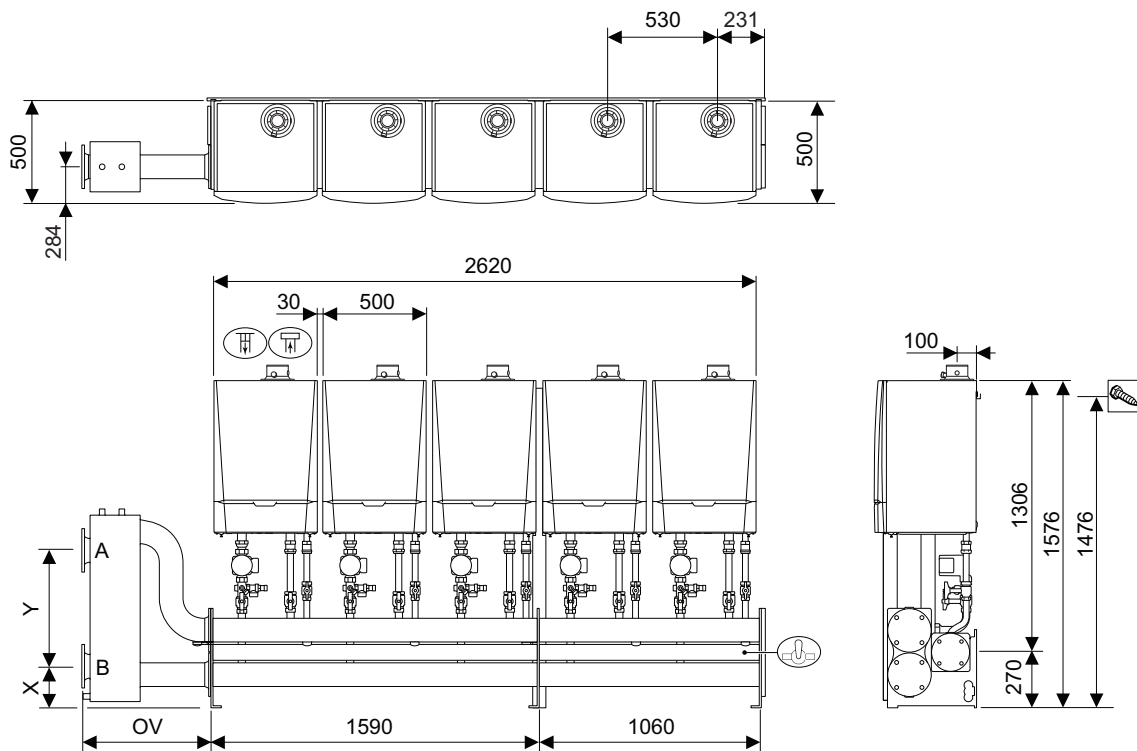
5.2.4. Installation drawing with 5 boilers - LW





T003413-A

- A** System flow; connection DN 100 or 125/ DIN 2631 (8 holes)
- B** System return; connection DN 100 or 125/ DIN 2631 (8 holes)
-  Gas supply connection DN 50 or 65/ DIN 2633 (4 holes)
-  Air inlet / Flue gas discharge concentric connection
Quinta Pro 30/45 = 80 / 125 mm, Quinta Pro 65/90/115 = 100 / 150 mm
-  Suspension points
- OV** Low loss header ; DN 65 = 633 mm DN 100 = 643 mm
- X** Distance to system return connection = 200 mm
- Y** Distance to system flow connection = 560 mm

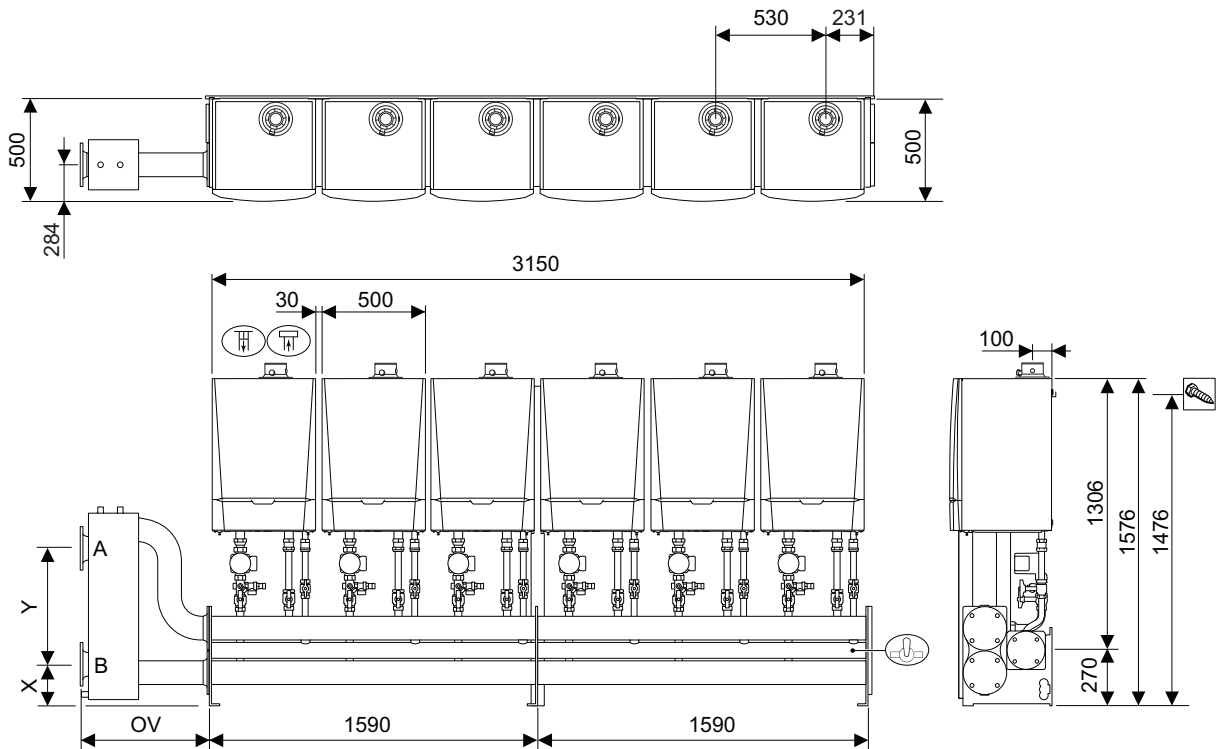
5.2.5. Installation drawing with 6 boilers - LW



T003414-A



- A** System flow; connection DN 100 or 125/ DIN 2631 (8 holes)
- B** System return; connection DN 100 or 125/ DIN 2631 (8 holes)
-  Gas supply connection DN 50 or 65/ DIN 2633 (4 holes)
-  Air inlet / Flue gas discharge concentric connection
Quinta Pro 30/45 = 80 / 125 mm, Quinta Pro 65/90/115 = 100 / 150 mm
-  Suspension points
- OV** Low loss header ; DN 65 = 633 mm DN 100 = 643 mm
- X** Distance to system return connection = 200 mm
- Y** Distance to system flow connection = 560 mm

5.3 Free-standing linear configuration - LV

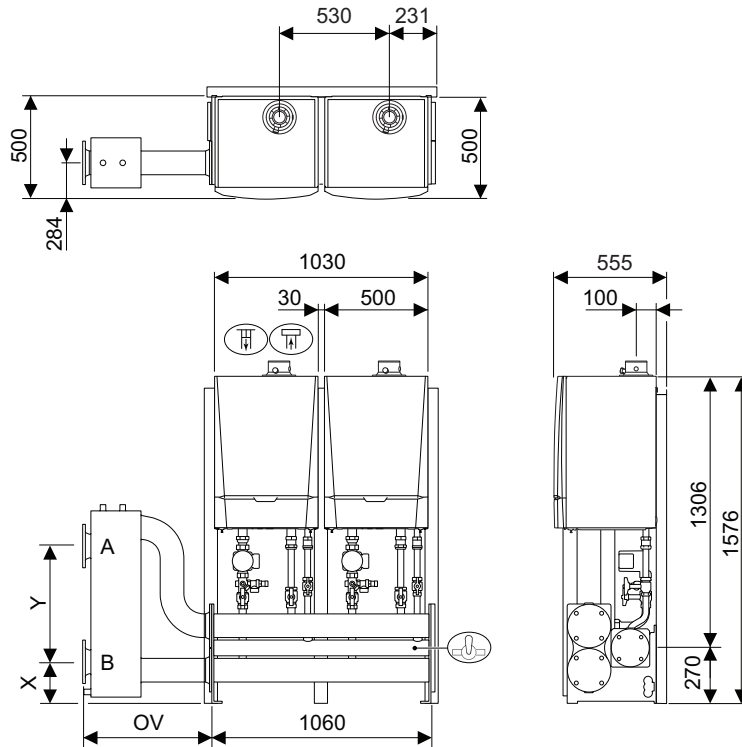
5.3.1. Installation drawing with 2 boilers - LV





T003415-A

- A** System flow; connection DN 100 / DIN 2631 (8 holes)
- B** System return; connection DN 100 / DIN 2631 (8 holes)
-  Gas supply connection DN 50 / DIN 2633 (4 holes)
-  Air inlet / Flue gas discharge concentric connection
Quinta Pro 30/45 = 80 / 125 mm, Quinta Pro 65/90/115 = 100 / 150 mm
-  Suspension points
- OV** Low loss header ; DN 65 = 633 mm DN 100 = 643 mm
- X** Distance to system return connection = 200 mm
- Y** Distance to system flow connection = 560 mm

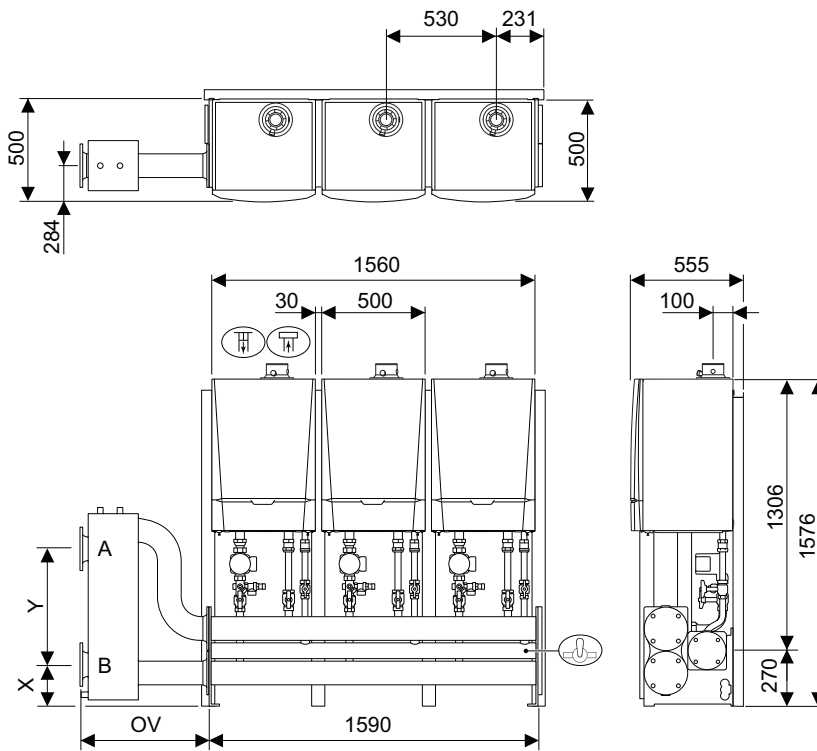
5.3.2. Installation drawing with 3 boilers - LV





T003416-A

- A** System flow; connection DN 100 / DIN 2631 (8 holes)
- B** System return; connection DN 100 / DIN 2631 (8 holes)
-  Gas supply connection DN 50 / DIN 2633 (4 holes)
-  Air inlet / Flue gas discharge concentric connection
Quinta Pro 30/45 = 80 / 125 mm, Quinta Pro 65/90/115 = 100 / 150 mm
-  Suspension points
- OV** Low loss header ; DN 65 = 633 mm DN 100 = 643 mm
- X** Distance to system return connection = 200 mm
- Y** Distance to system flow connection = 560 mm

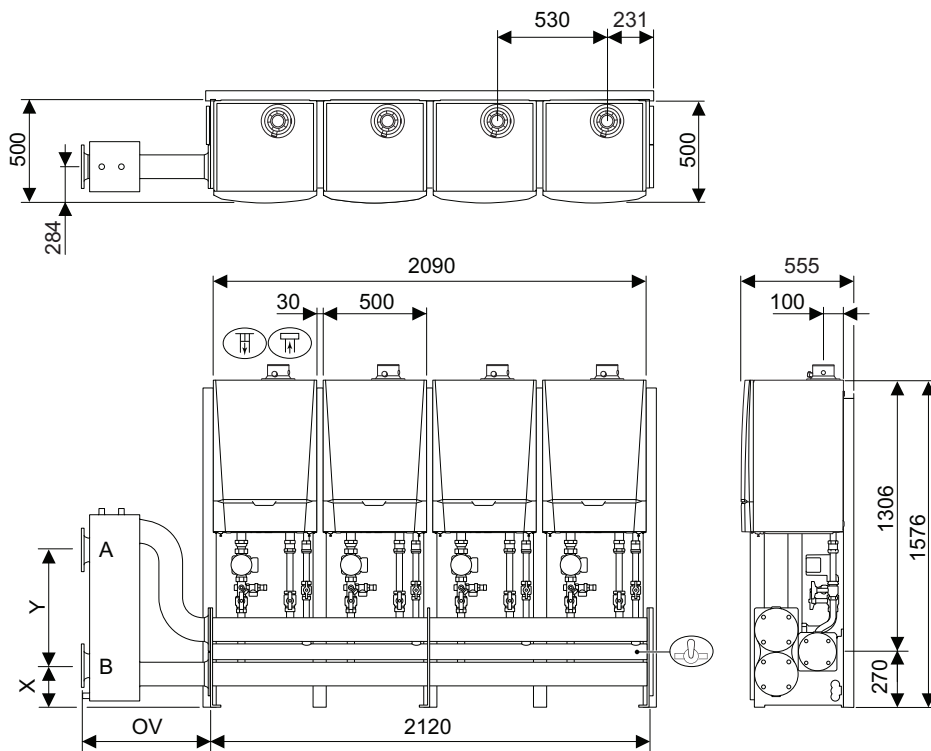
5.3.3. Installation drawing with 4 boilers - LV





T003417-A

- A** System flow; connection DN 100 / DIN 2631 (8 holes)
- B** System return; connection DN 100 / DIN 2631 (8 holes)
-  Gas supply connection DN 50 / DIN 2633 (4 holes)
-  Air inlet / Flue gas discharge concentric connection
Quinta Pro 30/45 = 80 / 125 mm, Quinta Pro 65/90/115 = 100 / 150 mm
-  Suspension points
- OV** Low loss header ; DN 65 = 633 mm DN 100 = 643 mm
- X** Distance to system return connection = 200 mm
- Y** Distance to system flow connection = 560 mm

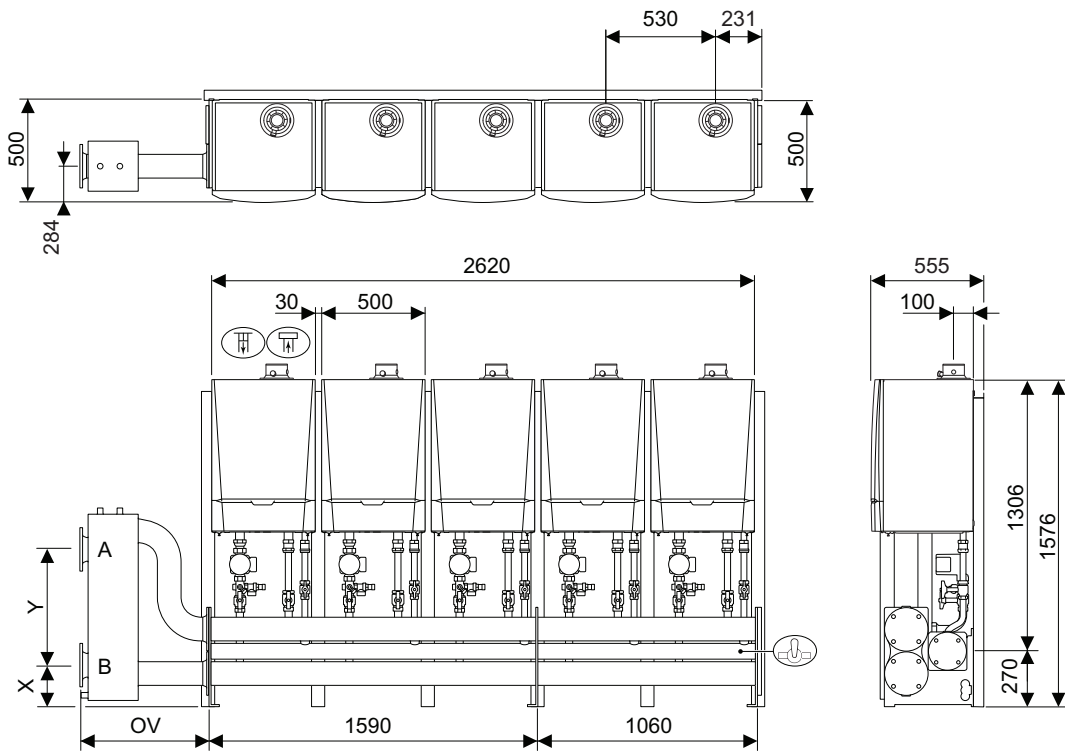
5.3.4. Installation drawing with 5 boilers - LV





T003418-A

- A** System flow; connection DN 100 or 125 / DIN 2631 (8 holes)
- B** System return; connection DN 100 or 125 / DIN 2631 (8 holes)
-  Gas supply connection DN 50 or 65 / DIN 2633 (4 holes)
-  Air inlet / Flue gas discharge concentric connection
Quinta Pro 30/45 = 80 / 125 mm, Quinta Pro 65/90/115 = 100 / 150 mm
-  Suspension points
- OV** Low loss header ; DN 65 = 633 mm DN 100 = 643 mm
- X** Distance to system return connection = 200 mm
- Y** Distance to system flow connection = 560 mm

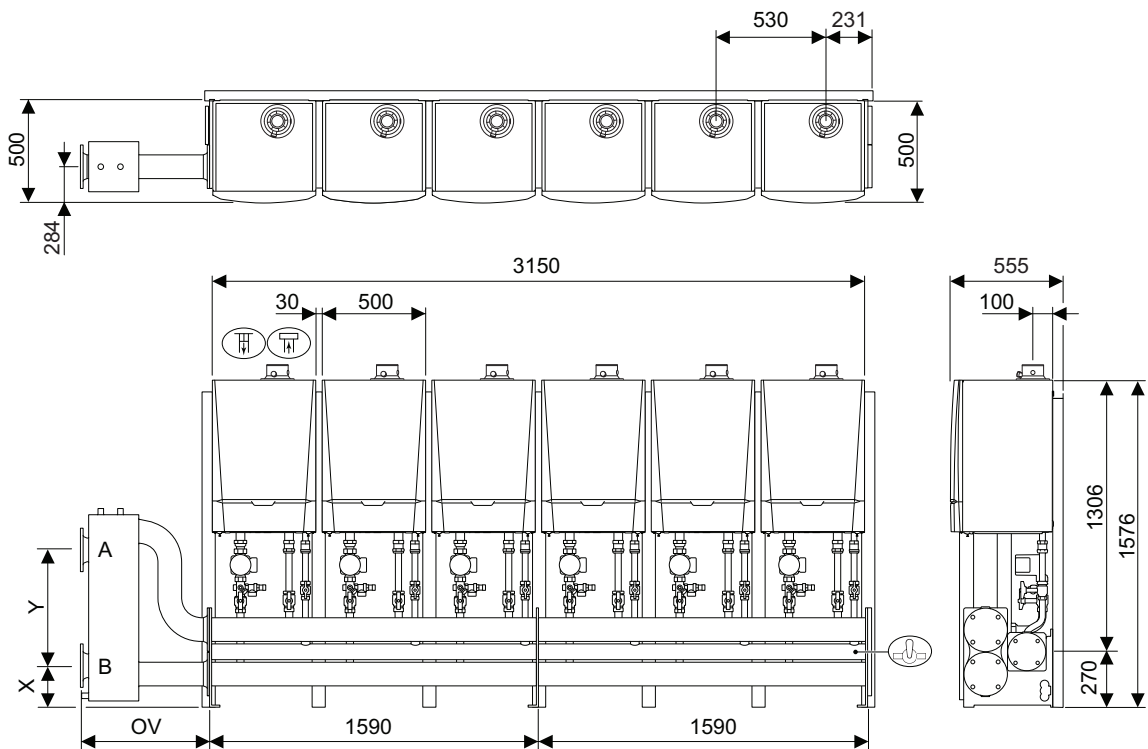
5.3.5. Installation drawing with 6 boilers - LV



T003419-A



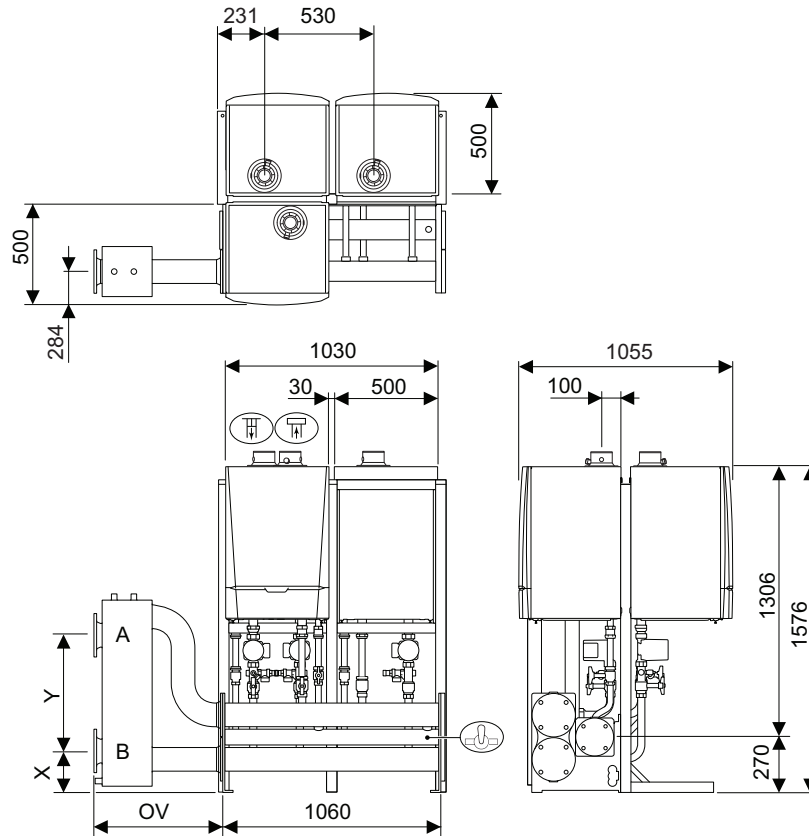

- A** System flow; connection DN 100 or 125 / DIN 2631 (8 holes)
- B** System return; connection DN 100 or 125 / DIN 2631 (8 holes)
-  Gas supply connection DN 50 or 65 / DIN 2633 (4 holes)
-  Air inlet / Flue gas discharge concentric connection
Quinta Pro 30/45 = 80 / 125 mm, Quinta Pro 65/90/115 = 100 / 150 mm
-  Suspension points
- OV** Low loss header ; DN 65 = 633 mm DN 100 = 643 mm
- X** Distance to system return connection = 200 mm
- Y** Distance to system flow connection = 560 mm

5.4 Back-to-back configuration - RG

5.4.1. Installation drawing with 3 boilers - RG





T003420-A

- A** System flow; connection DN 100 / DIN 2631 (8 holes)
- B** System return; connection DN 100 / DIN 2631 (8 holes)
-  Gas supply connection DN 50 / DIN 2633 (4 holes)
-  Air inlet / Flue gas discharge concentric connection
-  Quinta Pro 30/45 = 80 / 125 mm, Quinta Pro 65/90/115 = 100 / 150 mm
-  Suspension points
- OV** Low loss header ; DN 65 = 633 mm DN 100 = 643 mm
- X** Distance to system return connection = 200 mm
- Y** Distance to system flow connection = 560 mm

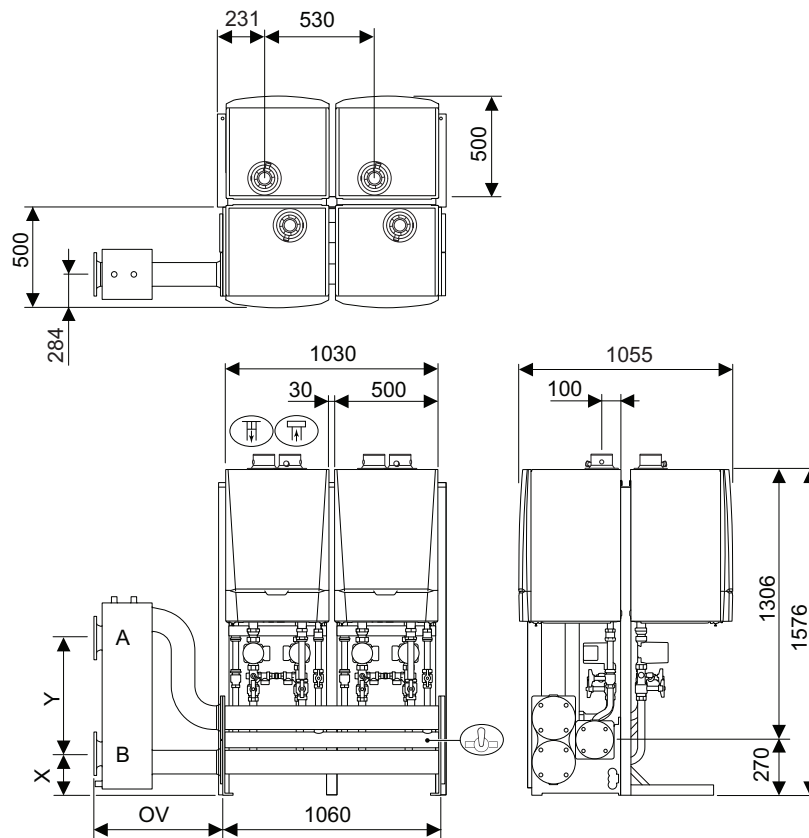
5.4.2. Installation drawing with 4 boilers - RG





T003421-A

- A** System flow; connection DN 100 / DIN 2631 (8 holes)
- B** System return; connection DN 100 / DIN 2631 (8 holes)
-  Gas supply connection DN 50 / DIN 2633 (4 holes)
-  Air inlet / Flue gas discharge concentric connection
Quinta Pro 30/45 = 80 / 125 mm, Quinta Pro 65/90/115 = 100 / 150 mm
-  Suspension points
- OV** Low loss header ; DN 65 = 633 mm DN 100 = 643 mm
- X** Distance to system return connection = 200 mm
- Y** Distance to system flow connection = 560 mm

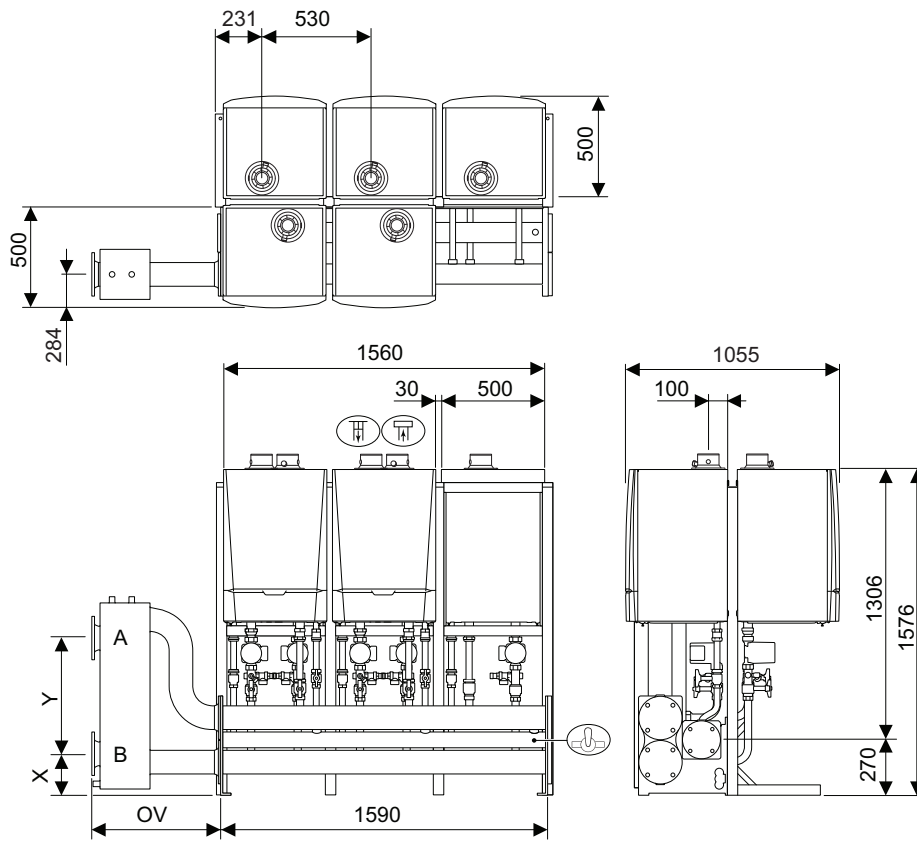
5.4.3. Installation drawing with 5 boilers - RG





T003422-A

- A** System flow; connection DN 100 or 125 / DIN 2631 (8 holes)
- B** System return; connection DN 100 or 125 / DIN 2631 (8 holes)
-  Gas supply connection DN 50 or 65 / DIN 2633 (4 holes)
-  Air inlet / Flue gas discharge concentric connection
Quinta Pro 30/45 = 80 / 125 mm, Quinta Pro 65/90/115 = 100 / 150 mm
-  Suspension points
- OV** Low loss header ; DN 65 = 633 mm DN 100 = 643 mm
- X** Distance to system return connection = 200 mm
- Y** Distance to system flow connection = 560 mm

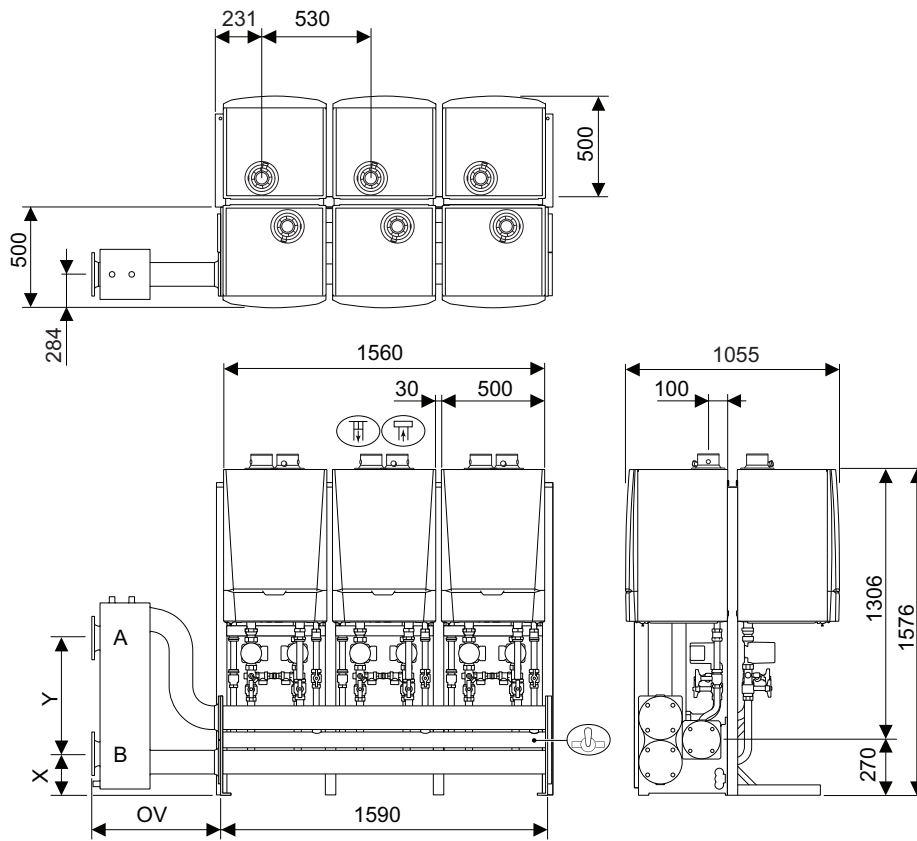
5.4.4. Installation drawing with 6 boilers - RG



T003423-A

- A** System flow; connection DN 100 or 125 / DIN 2631 (8 holes)
- B** System return; connection DN 100 or 125 / DIN 2631 (8 holes)
-  Gas supply connection DN 50 or 65 / DIN 2633 (4 holes)
-  Air inlet / Flue gas discharge concentric connection
Quinta Pro 30/45 = 80 / 125 mm, Quinta Pro 65/90/115 = 100 / 150 mm
-  Suspension points
- OV** Low loss header ; DN 65 = 633 mm DN 100 = 643 mm
- X** Distance to system return connection = 200 mm
- Y** Distance to system flow connection = 560 mm

6 Independently installed cascade systems

6.1 General

It is also possible to have an independently installed cascade system consisting of several units. You then determine the position of the boilers and the piping for your specific situation. To make this easier to do, this chapter provides a summary and description of the components to be used.

The components of the cascade systems are also available individually for independent assembly. The boiler connection kits, which include the unique, cast return-shut-off valve, are particularly interesting, because of their reasonable price and installation measurements. The following functions are integrated in the return shut-off valve (this makes this valve less expensive than the individual components):

- ▶ Service shut-off valve.
- ▶ Safety valve.
- ▶ Non-return valve.
- ▶ Filling and draining valve.
- ▶ Connection for expansion vessel.

6.2 Standard cascade system

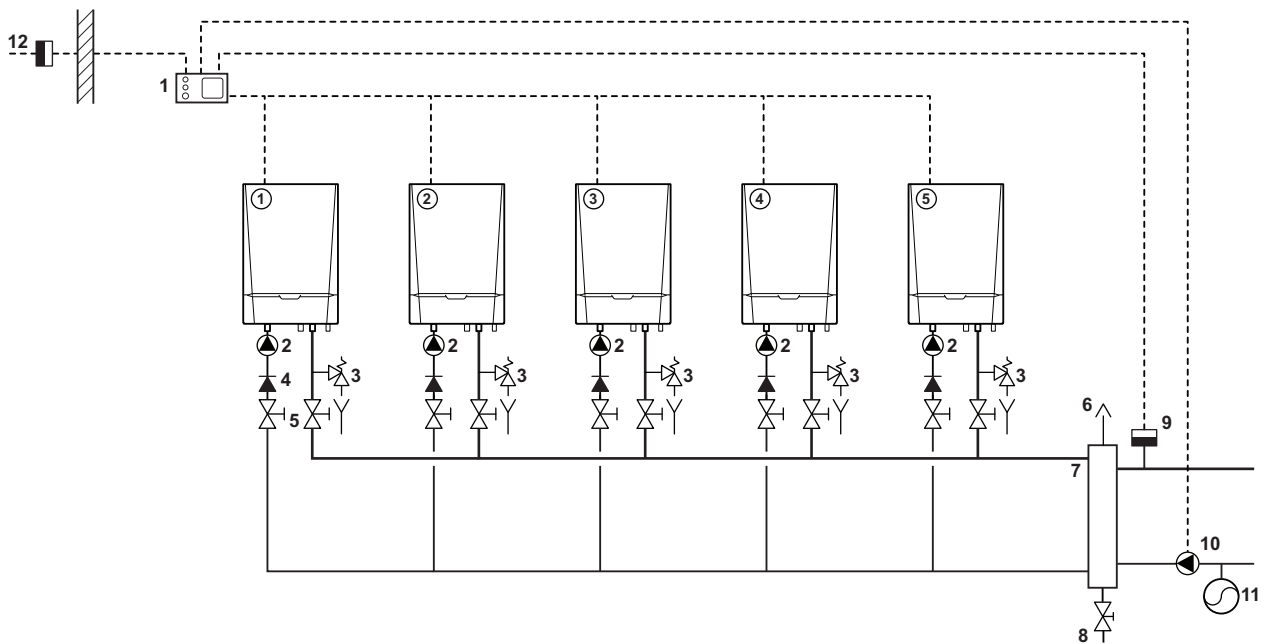

T003286-B

- | | |
|-----------|--|
| 1 | Cascade controller |
| 2 | Boiler pump |
| 3 | Safety valve |
| 4 | Non-return valve |
| 5 | Manual seal |
| 6 | Air vent |
| 7 | Low loss header |
| 8 | Drain cock |
| 9 | Flow sensor (Clamp sensor or immersion sensor) |
| 10 | System pump |
| 11 | Expansion vessel |
| 12 | Outside temperature sensor |

The schematic diagram of a standard cascade system is shown in the illustration. On the first circuit (boiler side), the central heating units are connected in parallel. The second circuit (system side) is formed by one or more system groups.

6.3 Dimensioning a standard low loss header

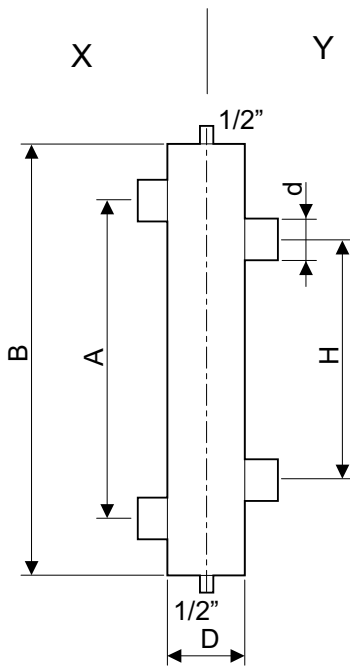

- X** Boiler-side connection
- Y** System-side connection

The low loss header serves to isolate the boiler circuit from the system circuit. The resistance of the low loss header must be very low. The rate of flow in the low loss header must not exceed 0.25 m/s. Please refer to the table for the correct dimensions of a standard low loss header.

T003267-C

Power range	Capacity Q	d	D Ø		D □	H	A	B
kW	m ³ /h on ΔT = 11°C	Inch	Inch	DN mm	mm	mm	mm	mm
80	6.25	1.25	4	100	100	316	421	554
100	7.82	1.25	5	125	110	353	470	608
120	9.38	1.5	5	125	120	386	515	656
140	10.95	2	6	150	130	417	557	700
160	12.51	2	6	150	140	446	595	742
180	14.07	2	6	150	140	473	631	781
200	15.64	2	8	200	150	499	665	818
220	17.20	2.5	8	200	160	523	698	853
240	18.76	2.5	8	200	170	546	729	886
260	20.33	2.5	8	200	170	569	758	918
280	21.89	2.5	8	200	180	590	787	949
300	23.45	2.5	8	200	190	611	815	979
320	25.02	2.5	10	250	190	631	841	1008
360	28.15	3	10	250	200	669	892	1063
400	31.27	3	10	250	210	705	941	1115
440	34.40	3	10	250	220	740	987	1165
480	37.53	3	10	250	230	773	1030	1212
520	40.65	4	12	300	240	804	1073	1257
560	43.78	4	12	300	250	835	1113	1301
600	46.91	4	12	300	260	864	1152	1343
640	50.04	4	12	300	270	892	1190	1384
680	53.16	4	12	300	280	920	1226	1423
720	56.29	4	14	350	280	947	1262	1462
750	58.64	4	14	350	290	966	1288	1490

6.4 DUO and TRIO low loss headers

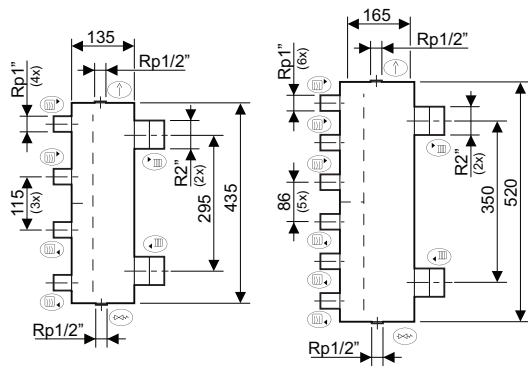

T003288-B

- Boiler flow
- Boiler return
- System flow
- System return
- Bleed valve
- Drain cock

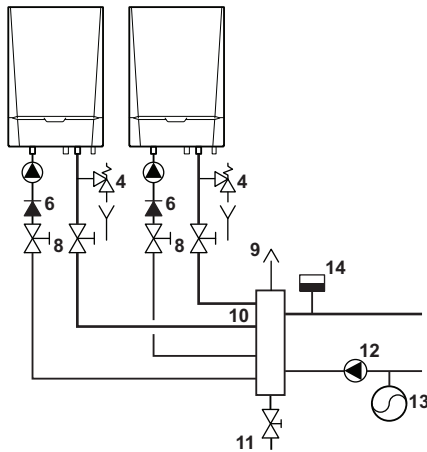

T003289-C

- 1 Boiler shunt pump
- 4 Safety valve
- 6 Non-return valve
- 8 Manual seal
- 9 Bleed valve
- 10 Low loss header (DUO low loss header)
- 11 Drain cock
- 12 System pump
- 13 Expansion vessel
- 14 Flow sensor (Clamp sensor or immersion sensor)

For the installation of 2 or 3 Quinta Pro 30, Quinta Pro 45 and/or Quinta Pro 65 wall-hung boilers, our range of products includes special compact low loss headers, the DUO and TRIO low loss headers respectively. The flow and return (1") of the Quinta Pro 30/45/65 boilers can be directly connected to these. There are two (1/2" female thread) connections above and below the low loss header for installing an air vent and a drain cock. To ensure they operate correctly, the low loss header must be assembled vertically.

6.5 Boiler and system pumps

The total output of the system pump(s) must not be more than the joint capacity Q of the boiler pumps. Otherwise, with full take-up, the system pump will pump part of the system return water straight to the system flow. This means that the flow temperature to the system will be lower than the flow temperature from the boilers. In addition, the selected system pump must be able to overcome the hydraulic resistance from the system. We have boiler pumps available for each boiler sized for nominal flow rate based on a design condition of 20°C ΔT on the boiler primary side of the header:

- ▶ Typical pump Quinta Pro 30 Grundfos UPS / 25-70
- ▶ Typical pump Quinta Pro 45 Grundfos UPS / 25-70
- ▶ Typical pump Quinta Pro 65 Grundfos UPS 25-70
- ▶ Typical pump Quinta Pro 90 Grundfos 25-80 (setting II)

► Typical pump Quinta Pro 115 Grundfos 25-80 (setting III)



Actual pump supplied may be different to that listed but with a similar duty.

The pump will be more than adequate for the cascade configurations illustrated and the Remeha cascade systems

The boiler resistance for the Quinta Pro 30/45/65/90/115 is shown in the graphs.

Quinta Pro 30

ΔP Boiler resistance

M^3/h Flow rate

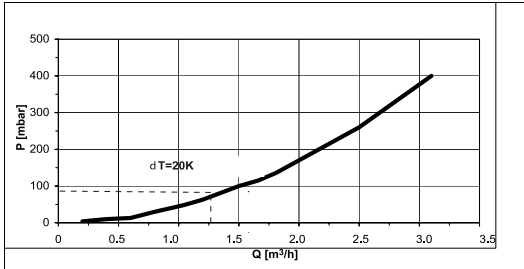

Quinta Pro 45

ΔP Boiler resistance

M^3/h Flow rate

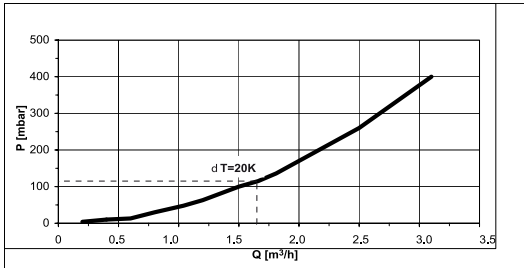

Quinta Pro 65

ΔP Boiler resistance

M^3/h Flow rate

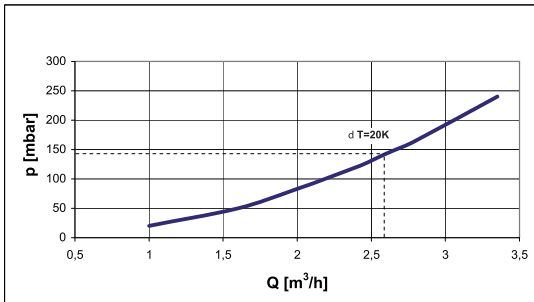

Quinta Pro 90

ΔP Boiler resistance

M^3/h Flow rate

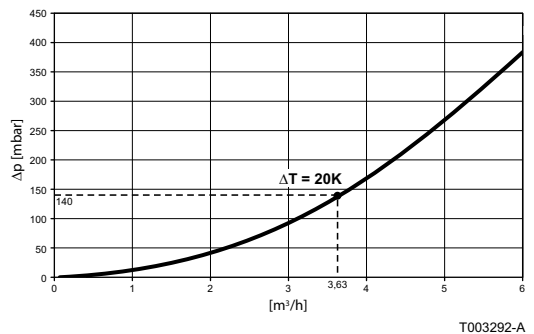

T003292-A

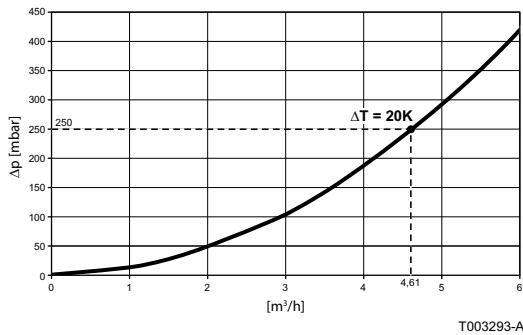

Quinta Pro 115

ΔP Boiler resistance
 M^3/h Flow rate

6.6 Non-return valve

Install (spring-loaded) non-return valves in the boilers' return pipes to avoid water flowing back to the boilers that are not in operation. This means that a boiler that is not operating is hydraulically switched off, thus avoiding undesired heat loss.

6.7 Overflow valve and manual seals

Install a safety valve between the manual seal and the unit to protect against an unacceptably high pressure. The overflow valve must be connected to the condensate drain with an open connection.

6.8 Expansion vessel

Fit an overflow valve for each boiler in the cascade system. "You do not have to equip each boiler with an expansion vessel; a central expansion vessel may be used". This must be installed in the return pipe of the system side. In this case, it must only be possible to shut off the expansion vessel using special tools (see regulations). When using an indirectly heated calorifier on one or more boilers, this/these boiler(s) must have an additional expansion vessel. This also applies if part of the system is isolated by means of a heat exchanger.

6.9 Configuration and mounting

Select the desired combination of boilers on the basis of the required heat output. The boilers can be installed next to each other or back to back. Mount the boilers level on a sufficiently strong wall or mounting frame. We recommend a clearance of 1 m (at least 60 cm) in front of the units. Since all components are accessed from the front, only minimal clearance is required on the left- and right-hand sides. A clearance of at least 1 cm between units is recommended to ensure that the front panel opens easily. We recommend a clearance of at least 40 cm above the units. To determine the clearance below the boilers, the dimensions of fittings, connection pipes and low loss header must be taken into account.

7 Gas connection

7.1 General

The boilers are suitable for use with all types of natural gas and propane category II_{2H3P}. Connect the boilers to the gas mains in accordance with the applicable regulations. For the Quinta Pro boilers, the gas connections are at the bottom of the boiler and are ¾" male thread. There must be a main gas cock close to the boilers. Install gas filters in the gas supply pipe to avoid contamination of the gas multiblocks. When cascade systems are used, manual seals for the gas pipes are included for each boiler. A gas filter for the gas supply pipe is available as an accessory.

7.2 Gas pressures

The required inlet working pressure per boiler is 17 to 30 mbar. The correct burner pressure setting for natural gas H-Gas (G20) was set at the factory and, in principle, does not need readjusting. For propane operation, see the installation service manual for the boilers concerned. The usual inlet pressure for commercial propane (37-50 mbar) can be used.

8 Connections for the air and exhaust pipes

8.1 General

The boilers can be used in room-ventilated or room-sealed operation. The room-open version extracts the necessary combustion air from its environment. In this case via an air supply opening at the top of the boilers. By installing an air supply pipe on the air supply opening, you obtain a room-sealed system.

8.2 Individual flue gas discharge

If there is insufficient height for a joint flue gas discharge and/or air supply, individual roof feed-throughs can be fitted. For room-sealed systems, the individual roof feed-throughs must be installed at the same height on flat or sloping roofs. This avoids flue gases from one boiler being taken in by another boiler. From an aesthetic point of view, the individual roof feed-throughs can be placed within a single feed-through construction. Recirculation problems may arise where discharge takes place into recesses and in the vicinity of rising walls.



If in doubt, please contact us.

8.3 Joint flue gas discharge

If there is sufficient height, a collector system can be used (not supplied by us). In the design of the collector system, a distinction is made between a series or parallel configuration. This document only covers the series configuration.

In series configurations, individual boilers are connected directly to a horizontal collector, which then continues on to the vertical section. An advantage of this configuration is that only one (room-ventilated operation) or two (room-sealed operation) collector pipes run immediately above the boilers. It is also possible to link several boilers under overpressure on the flue gas side: This results in smaller diameters of the flue gas discharge pipe. For this purpose, the Quinta Pro boilers have a flue gas non-return valve as standard. This creates a considerable saving on the cost of a combined flue-gas-discharge system with several boilers switched in a cascade. The boiler's parameter settings will need to be changed.



Consult our Technical department about this.

8.4 Material requirements

When combining different metals, these must be galvanically isolated. Galvanic isolation (rubber inlay) is also required when using brackets made from a different metal. Fit the flue gas discharge pipe so that it has airtight and watertight joints and connections.

Flue gas discharge material

Because the flue gases condense, the flue gas discharge must not be connected to a brick duct. In situations of this kind, always use a lining tube.

Depending on the design, the following materials may be used:

Material		
A rigid wall ⁽¹⁾	Thick aluminium wall	Approval according to EN-1856-1
	Stainless steel	Approval according to EN-1856-1
	Synthetic material T120	Approval according to Gastec QA or KOMO
Flexible ⁽¹⁾	Stainless steel	Approval according to EN-1856-1
	Synthetic material T120	Approval according to Gastec QA or KOMO
⁽¹⁾ The sealing must conform with pressure class 1		



External components must always be insulated.

Air inlet equipment

Depending on the design, the following materials may be used:

Material	
A rigid wall	aluminium/Stainless steel/Synthetic material
Flexible	



If condensate forming on the air supply collector is problematic, it must be insulated so that it is steamtight.

8.5 Condensate drain

Because the flue gases condense in the discharge system, condensed water develops and must be discharged. As a rule of thumb, we anticipate a maximum of 1 litre of condensed water per m³ of natural gas consumed. In practice, this amounts to:

- ▶ approx. 5 litre of condensate per hour for the Quinta Pro 45.
- ▶ approx. 7.5 litre of condensate per hour for the Quinta Pro 65
- ▶ approx. 10 litre of condensate per hour for the Quinta Pro 90
- ▶ approx. 12.5 litre of condensate per hour for the Quinta Pro 115

In addition to the condensate drain on each individual boiler, in the case of a joint flue gas discharge, an additional condensate collector must be placed at the bottom of the vertical duct. When using different materials, the condensed water must be discharged separately for each section in a single type of material. Discharge the condensed water directly into the drain using a syphon. Make an open connection

with the drain. Condensed water must not be discharged into gutters: This prevents freezing and corrosion of the materials normally used for gutters. Horizontal sections in the flue gas discharge must slope down (5 cm/m) towards the boilers. Fit the individual boilers to the joint flue gas discharge so that no condensate can flow back into the boilers.

9 Exploded view

9.1 Exploded view

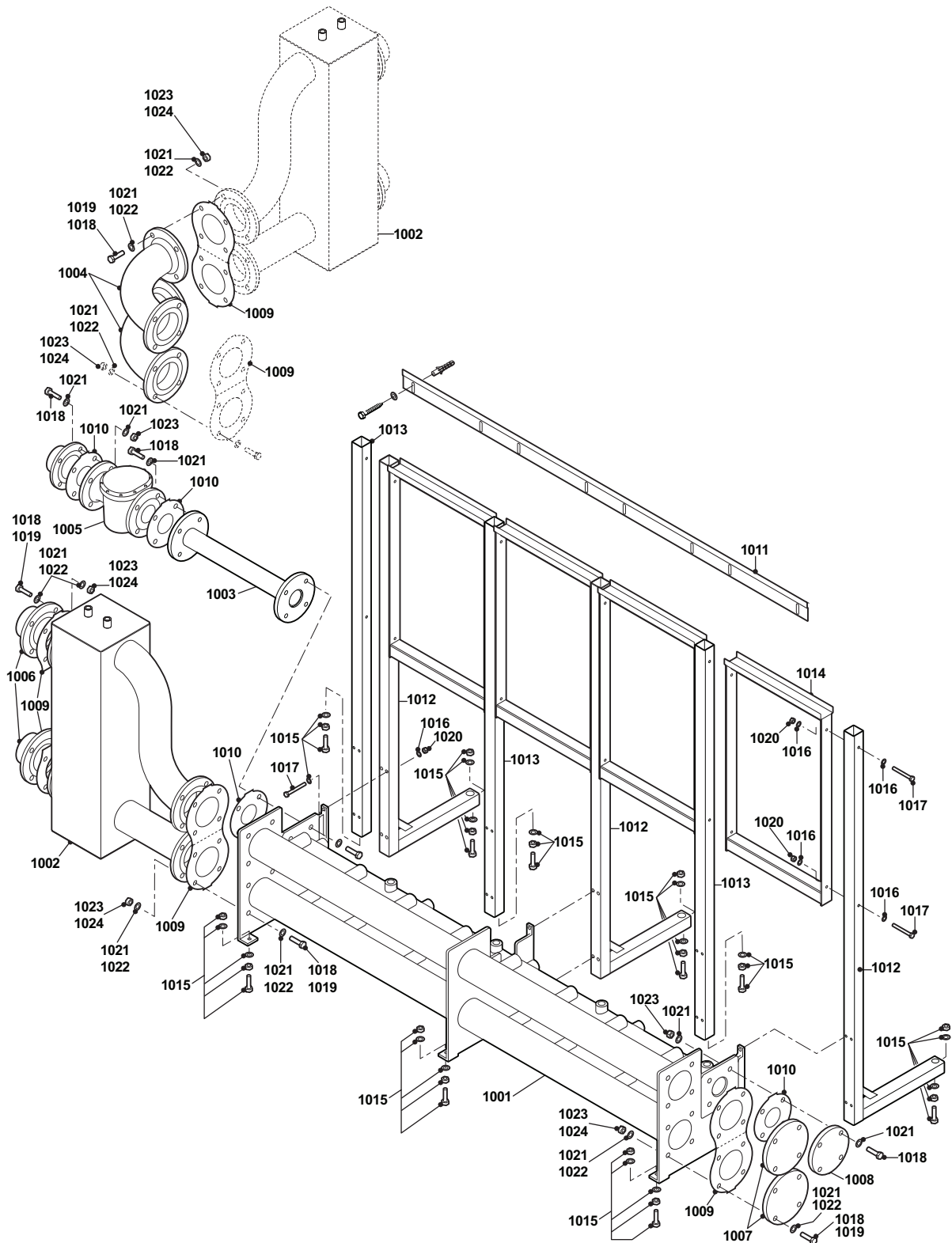

T003303-B

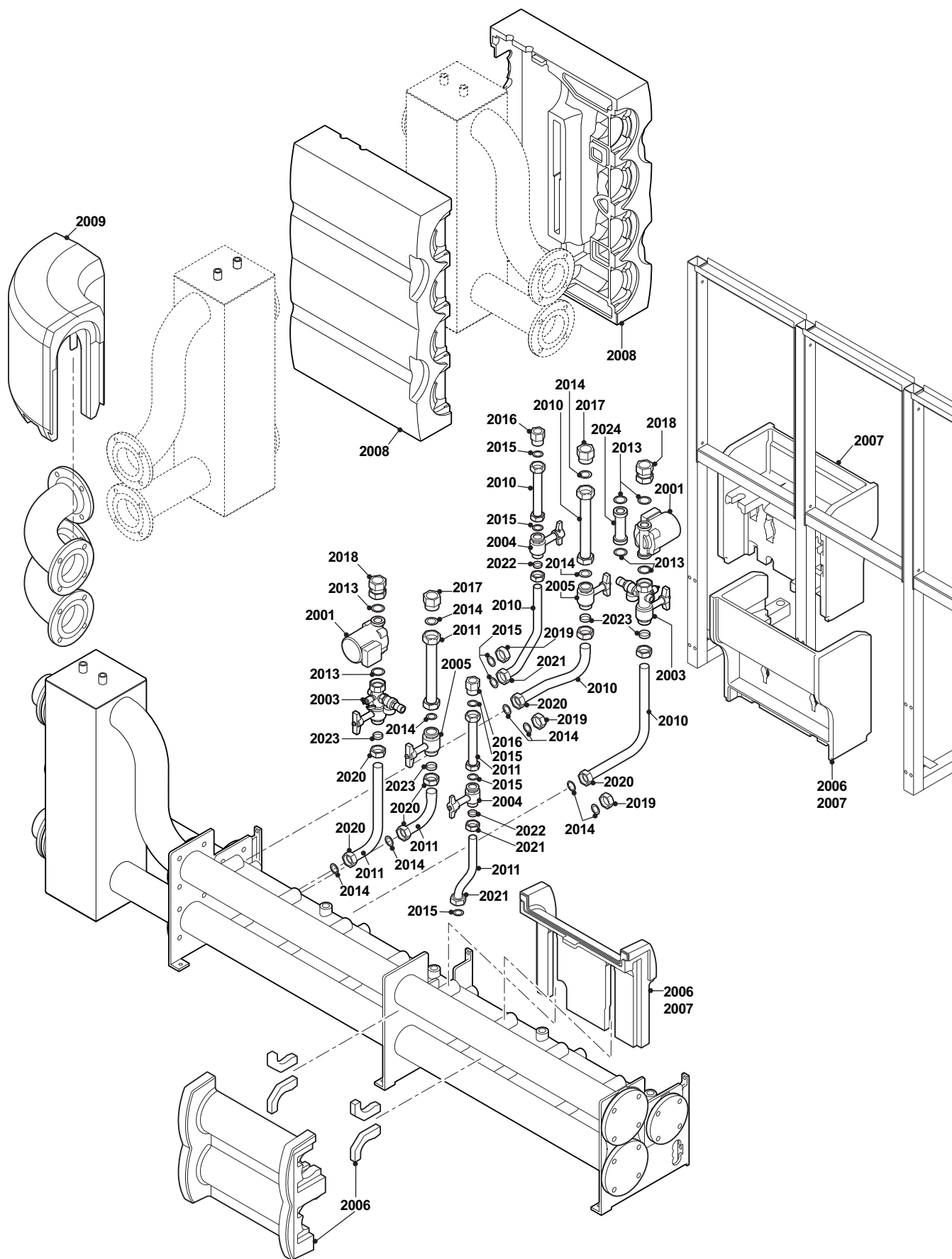

T003424-A

Markers	Description	Part
1001	Set of main pipes 100-4	1
1001	Set of main pipes 100-3	1
1001	Set of main pipes 100-2	1
1001	Set of main pipes 65-4	1
1001	Set of main pipes 65-3	1
1001	Set of main pipes 65-2	1
1002	Low loss header DN 65 Boiler side DN 65 Installation side: DN 100	1
1002	Low loss header DN 100 Boiler side: DN 100 Installation side: DN 125	1
1003	Gas supply pipe DN 65	1
1003	Gas supply pipe DN 50	1
1004	Elbow DN 65	1
1004	Elbow DN 100	1
1005	Gas filter DN 65	1
1005	Gas filter DN 50	1
1006	Connecting flanges DN 100	1
1006	Connecting flanges DN 125	1
1007	Blind flange DIN 2527 / DN 100	1
1007	Blind flange DIN 2527 / DN 65	1
1008	Blind flange DIN 2527 / DN 50	1
1008	Blind flange DIN 2527 / DN 65	1
1009	Sealing plate Ø 100	10
1009	Sealing plate Ø 65	10
1009	Gasket ring Ø 125	10
1009	Gasket ring Ø 100	10
1010	Gasket ring Ø 50	10
1010	Gasket ring Ø 65	10
1011	Wall-mount bracket LW 2	1
1011	Wall-mount bracket LW 3	1
1011	Wall-mount bracket LW 4	1
1012	Stand at right angles	1
1013	Stand	1
1014	Assembly frame horizontal	1
1015	Height adjustment	1
1016	Washer Ø 8.4 mm	25
1017	Screw M8 x 70	20
1018	Bolt M16 x 50	20
1019	Bolt M12 x 45	20
1020	M8 nut	20
1021	Washer Ø 17 mm	20
1022	Washer Ø 13 mm	20
1023	M16 nut	20
1024	M12 nut	20
2001	Pump Grundfos 25-60 , 25-70, 25-80	1
2003	Return cock	1
2004	Gas cock	1
2005	Flow cock	1
2006	Set of insulation parts LV/LW	1

Markers	Description	Part
2007	Set of insulation parts RG	1
2008	Insulation parts for low loss header	1
2009	Insulation for elbow	1
2010	Boiler connection kit/main pipe for back-to-back configuration	1
2011	Set of pipes LV/LW including connections	1
2013	Gasket ring \varnothing 44x32x4	10
2014	Gasket ring \varnothing 44x32x3	10
2015	Gasket ring \varnothing 38x25x3	10
2016	Screw coupling 1" - 1¼"	1
2017	Screw coupling 1¼" - 1½"	1
2018	Screw coupling 1¼" - 1½"	1
2019	Cap set	1
2020	Union nut 1½"	10
2021	Union nut 1¼"	10
2022	Compression ferrule 28 mm	10
2023	Compression ferrule 35 mm	10

Broag Ltd.
Remeha House
Molly Millars Lane
RG41 2QP WOKINGHAM,
Berks.

Tel: +44 118 9783434
Fax: +44 118 9786977
Internet: uk.remeha.com
E-mail: boilers@broag-remeha.com

© Copyright

All technical and technological information contained in these technical instructions, as well as any drawings and technical descriptions supplied, remain our property and shall not be multiplied without our prior consent in writing.

081110



124823

 **remeha**