

# BAXI

Please read these instructions before installing or commissioning.  
The Solarflo - Solar Thermal Domestic Hot Water System should  
only be installed by a competent person.  
Please leave these instructions with the user for safe keeping.

## Installation Guide - On Roof Flat Plate Solar Collector Mounting



## Solarflo - Solar Thermal Domestic Hot Water System

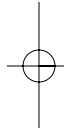
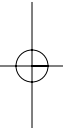
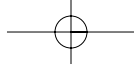

© BAXI Heating UK Ltd 2007. All rights reserved. No part of this publication may be reproduced or transmitted in any form or by any means, or stored in any retrieval system of any nature (including in any database), in each case whether electronic, mechanical, recording or otherwise, without prior written permission of the copyright owner, except for permitted fair dealing under Copyrights, Designs and Patents Act 1988.

Applications for the copyright owner's permission to reproduce or make other use of any part of this publication should be made, giving any details of the proposed use to the following address:

The Company Secretary, BAXI Heating UK Ltd, The Wyvern Business Park, Stanier Way, Derby DE21 6BF.

Full acknowledgement of author and source must be given.

WARNING: Any person who does any unauthorised act in relation to a copyright work may be liable to criminal prosecution and civil claims for damages.

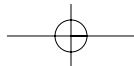

## Index

### 3 Index

#### 4 General

Safety information

#### 6 Installation of on roof flat panel solar collector

Lifting the panel

General assembly notes

Mounting kit parts list - Slate and Flat Tile

Suggested attachment points

Mounting system - Flat Tile

Mounting system - Slate

Mounting rail assembly

Mounting kit parts list - profiled tiles

Suggested attachment points

Mounting system - profiled tiles

Mounting rail assembly

#### 26 Installation of collector panel sensor

#### 27 Spares

## 1.0 General

### 1.1 Safety information

In order to reduce the number of deaths and major accidents attributable to work at height, the Health and Safety Executive has introduced comprehensive regulations and guidance that should be followed by all businesses working at height.

We consider in the following paragraphs some of the main features of the regulations and guidance. This is, however, only a limited summary and it is recommended that all businesses planning on undertaking solar water heating installations obtain a copy of the regulations and guidance issued by the Health and Safety Executive and carefully consider the contents.

The regulations and guidance state that you are required to carry out a risk assessment for all work conducted at height and to put in place arrangements for:

- Eliminating or minimising risks from work at height.
- Safe systems of work for organising and performing work at height.
- Safe systems for selecting suitable work equipment.
- Safe systems for protecting people from the consequences of work at height.

#### **The regulations and guidance highlight a hierarchy for safe work at height:**

- **Avoid** the risk by not working at height if practicable.
- **Prevent** falls, where it is not reasonably practicable to avoid work at height; you are required to take suitable and sufficient steps to prevent the risk of a fall including selecting the most suitable work equipment (in accordance with the regulations).
- **Mitigate** the consequences of a fall; where the risk of a person or object falling still remains, take suitable and sufficient measures to minimise the distance and consequences of any fall.

Collective protection measures, such as guard rails on scaffold, should be given priority over personal protection measures, such as safety harnesses.

Within the regulations' framework, you are required to:

- 1) Assess the risk to help you decide how to work safely.
- 2) Follow the hierarchy for safe work at height (i.e. avoid, prevent and mitigate).
- 3) Plan and organise your work properly, taking account of weather conditions and the possibility of emergencies.
- 4) Make sure those working at height are competent.
- 5) Make use of appropriate work equipment.
- 6) Manage the risks from working on or around fragile surfaces and from falling objects.
- 7) Inspect and maintain the work equipment to be used and inspect the place where the work will be carried out (including access and egress).

When preparing to install a solar water heating system, it is required that you perform a risk assessment in relation to work at height and plan how you will organise your work, taking into account the site, the weather conditions and the experience and competence of colleagues or contractors who may be working at height with you.

## 1.0 General

### Risk Assessments

The HSE has published a number of very useful free publications that advise how to undertake risk assessments.

Two of these that you should obtain are:  
Five Steps to Risk Assessment.  
A Guide to Risk Assessment Requirements.

### The five steps outlined in the HSE leaflet are:

#### Step 1: Look for the hazards

This will mean looking at the site and identifying significant hazards. These could be features such as a steep roof, a fragile surface where the collectors may be mounted, uneven ground or obstructions where access to the roof might be required.

#### Step 2: Decide who may be harmed and how

This might mean considering the particular risks that young workers or trainees might face and thinking about the residents of the household or visitors who could be hurt by your activities.

**Step 3:** Evaluate the risks and decide which precautions should be made. You should consider how likely it is that each hazard will cause harm, decide which precautions you might take and then assess, after you have taken those precautions, whether the remaining risk will be high, medium or low. Where you identify remaining risks, you should consider which further action you could take to control the risks so that harm is unlikely.

#### Step 4: Record your findings

If you have fewer than five employees you do not need to write anything down, though it is useful to keep a written record of what you have done. If you employ five or more people you must record the significant findings of your assessment. You must also tell your employees about your findings. You need to be able to show that a proper check was made, that you considered who might be affected, that you dealt with all the obvious significant hazards, that the precautions you propose are reasonable and that the remaining risk is low.

#### Step 5: Review your assessment if necessary

Each solar water heating installation may bring its own challenges and present its own particular hazards. You should therefore be careful not to rely on a "standard" risk assessment for installing a solar water heating system in a house, but review the particular hazards for each new situation. The issue of work equipment must be considered, but at the preparation stage you should consider where scaffold or other access equipment might be positioned and look out for any obvious obstacles to this, such as a conservatory or porch.

In addition to the risks associated with work at height, you should also consider the risks associated with lifting and carrying solar collectors, using electric drills and using blow lamps or blow torches for soldering. This is not an exclusive list and you should consider all aspects of the proposed installation to assess whether there are additional risks that need to be taken into account.

Fig. 1

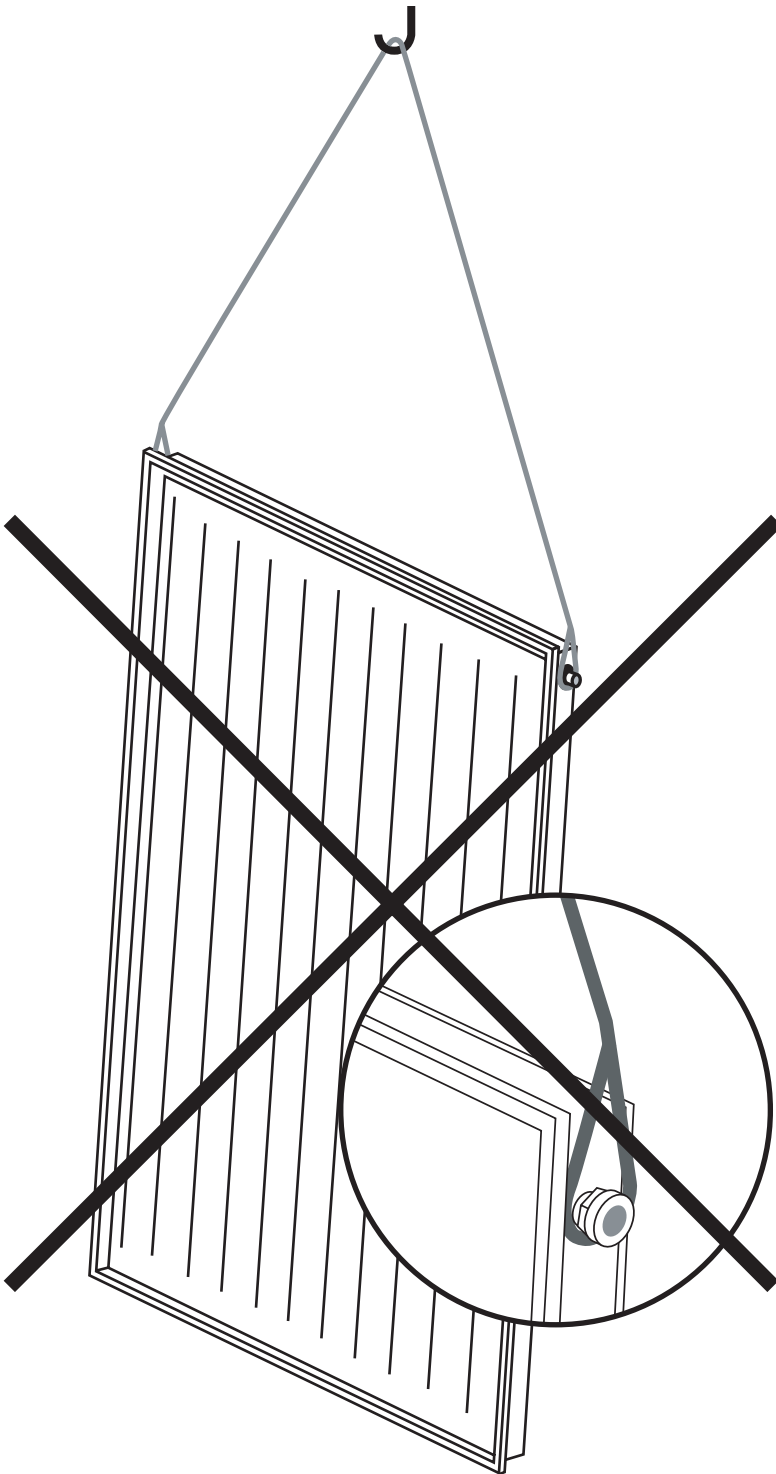

## 2.0 Installation of solar collector

### 2.1 Lifting the panel

**Do not** lift the collectors by the connections.

Refer to Section 2.2 of the Installation Guide Solar Collector Panel specifications for details of the dimensions and weight of each panel. Carrying/lifting straps must be securely fastened to the main framework of the panel. Point impact and loading of the glass panel must be avoided. The collector must not be installed if the glass panel is damaged in any way.

## 2.0 Installation of solar collector

### 2.2 General assembly notes

These instructions relate to the installation of the Baxi Solarflo on roof flat plate solar collector panels. Parts are provided for fixing to profiled, flat or slate tile roofs, not all parts will be required for each roof type. Refer to the parts list for each roof type to establish the correct components that need to be used in each case.

All other equipment must be installed as per detailed in the Baxi Solarflo Installation Guide.

Use only Baxi Solarflo mounting systems. Use of other brackets/mounting systems will invalidate the warranty and may result in an insecure and dangerous panel installation.

The mounting brackets or bench screws must be fixed to the roof structural members. They must never be fixed to roofing laths. If suitably positioned structural members are not available or, if they are of a section that may be weakened by the inserting of the fixing screws, additional noggins should be inserted between the structural members. These must be at least the same cross section as the structural member.

Use only the corrosion resistant fastenings supplied. Holes through any roof waterproofing materials should be sealed with an appropriate UV and weather resistant sealant.

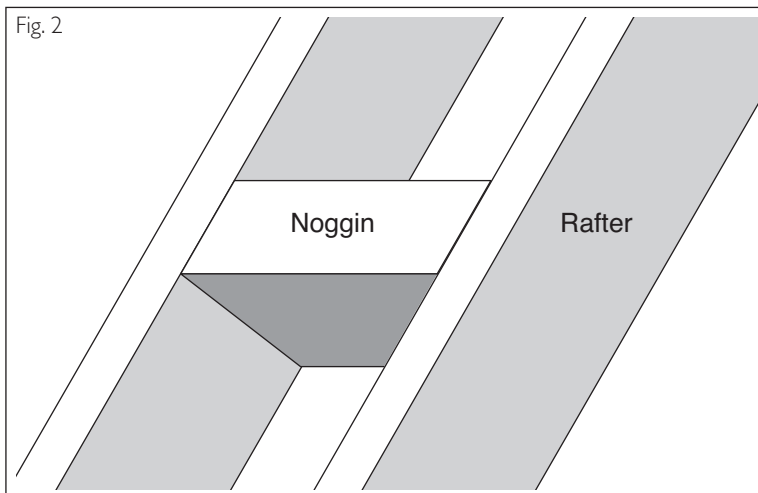

#### Structure

The collectors may only be mounted on sufficiently load-bearing roof surfaces and substructures. It is essential that the structural load-bearing capacity of the roof and the substructure must be assessed before mounting the collectors. Particular attention should be paid to the quality of the (timber) substructure in terms of the stability of the screw joints necessary for installing the collector mounting brackets. Anchor screws must be bolted into support with a minimum depth of 150mm. Where roof structure is not strong enough noggins must be inserted to accept anchor screws. The roof structure must be able to take the wind and snow loads that can occur. (Note: 1m<sup>2</sup> powder snow ~ 60kg / 1m<sup>2</sup> wet snow ~ 200kg). The assessment should also take into account any special features of the particular site that could lead to increased loads (air jets or eddy formations, etc). There must be at least 1m distance from roof ridging or edges.

#### Lightning protection / Equipotential bonding of the building

It is not necessary to connect collector arrays to the lightning protection of the building. For installations on metal substructures at the installation site, authorised lightning protection specialists must be consulted. The metal pipes of the solar circuit must be earth bonded to the main earthing circuit by means of a conductor (green/yellow) with a cross-section of at least 6mm<sup>2</sup>.

Fig. 3

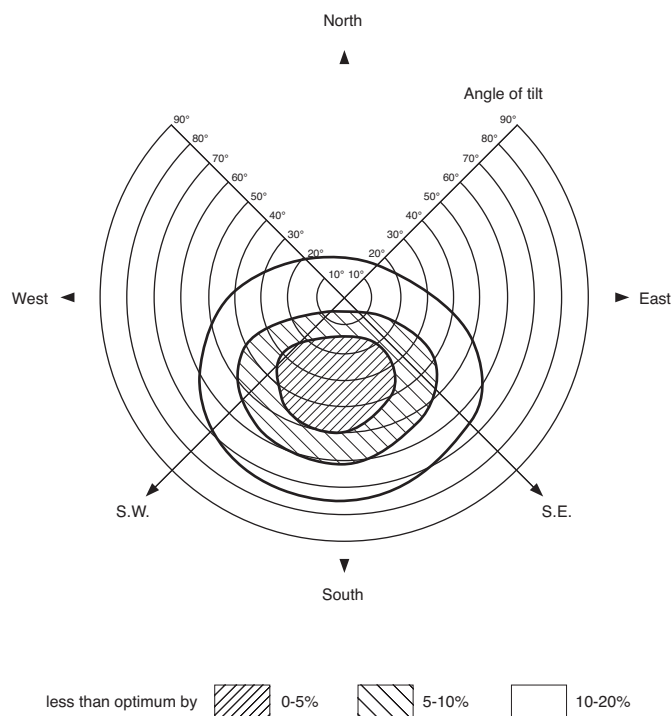

## 2.0 Installation of solar collector

Collector panels must be connected in series. The left hand connection is threaded  $\frac{3}{4}$ "BSP male. The right hand connection has a  $\frac{3}{4}$ "BSP female union connection. This enables the panels to be directly connected to each other. N.B. ensure the sealing washer provided is inserted between the male and female connections. All connecting pipe work and fittings must be of a suitable metal; either copper, brass or stainless steel. Soft soldered joints must not be used. Any seals or sealing compounds must be resistant to temperatures of up to 150°C and be resistant up to a 50% glycol/water mix.

### Connections

When tightening the connections, always apply counter-pressure with a wrench or another spanner to prevent damage to the absorber.

### Collector inclination

The collector is suitable for angles between 15° (minimum) and 75° (maximum).

The roof aspect should ideally face South, however orientations between 30° East and 40° West of South are acceptable. Fig.3 shows the efficiency loss for varying angles of inclinations and roof orientation.

### Solar fluid

The Baxi Solarflo collector panels **MUST** be protected with a water/glycol heat transfer fluid. Use only the fluid supplied with the system which is supplied pre-mixed to a concentration of 40% glycol / 60% water. Top ups can be made with water but the glycol concentration must not be allowed to fall below 30% or inadequate frost protection will be given. Systems found to have lower glycol concentrations will not be covered by the warranty.

## 2.3 Mounting kit parts list. Slate and Flat tile roofs

|                             | 1 panel | 2 panels | 3 panels |
|-----------------------------|---------|----------|----------|
| A. Bench screw              | 4       | 4        | 6        |
| B. Mounting part            | 4       | 4        | 6        |
| C. Rubber seal              | 4       | 4        | 6        |
| D. Clamping piece           | -       | 1        | 2        |
| E. Clamping piece extension | -       | 2        | 4        |
| F. Mounting part top        | 2       | 2        | 2        |
| G. Mounting part extension  | -       | 1        | 2        |
| H. M8 washer                | 6       | 6        | 8        |
| I. M8x30 hammer-head bolt   | 6       | 6        | 8        |
| J. M8 hex nut               | 6       | 6        | 8        |
| K. Support rail             | 2       | 4        | 6        |
| L. Mounting jig             | -       | 1        | 1        |
| M. Sealing washer           | 2       | 3        | 4        |
| N. M12 nut                  | 12      | 12       | 18       |
| O. M12 washer               | 12      | 12       | 18       |



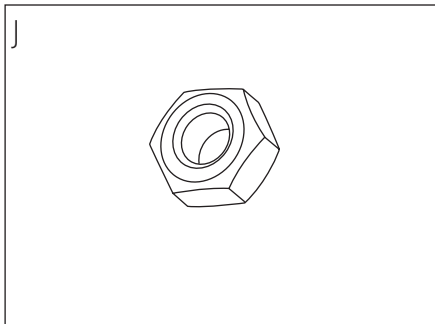
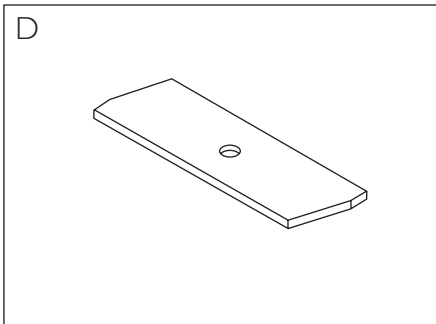
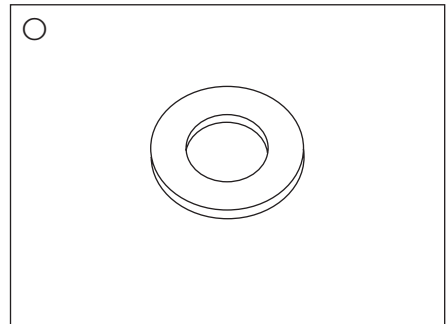
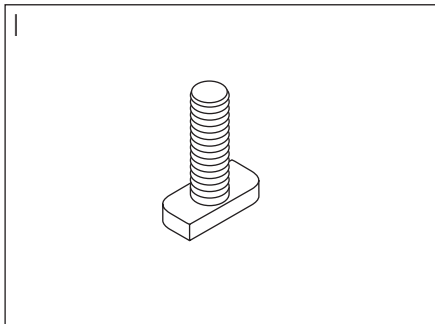
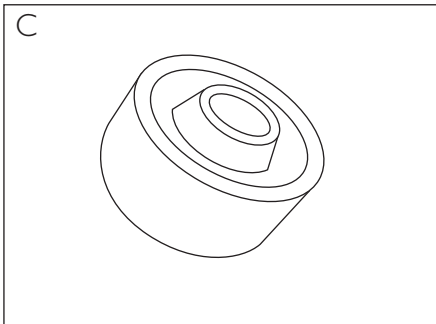
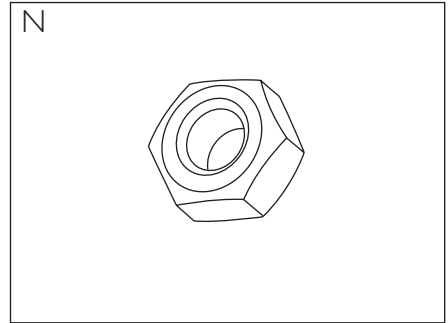
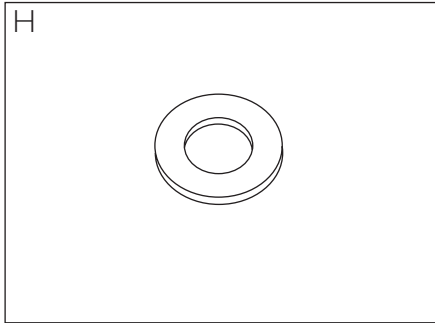
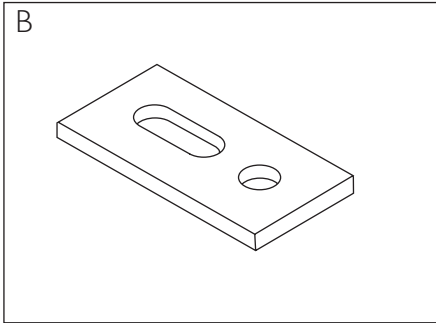
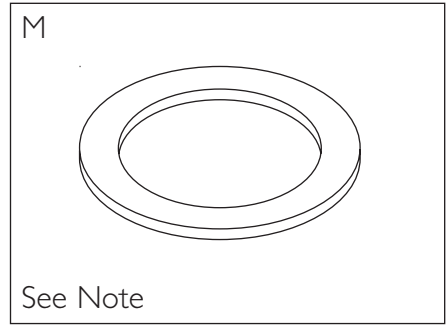
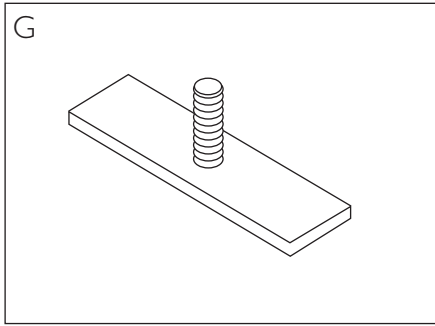
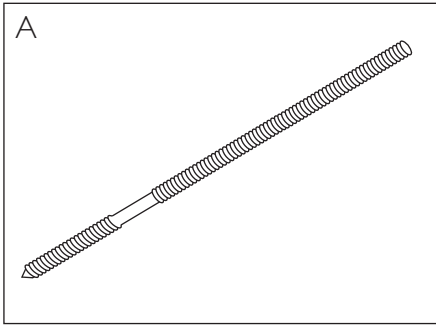

**NOTE:** 1 sealing washer is supplied with each solar collector panel. 2 sealing washers are supplied with the flexible connection pipes.

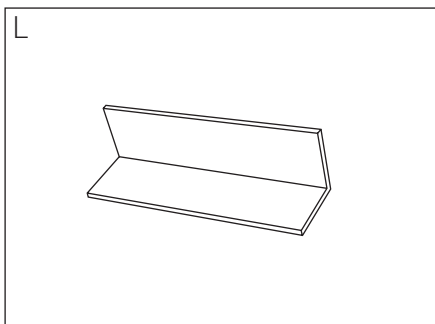
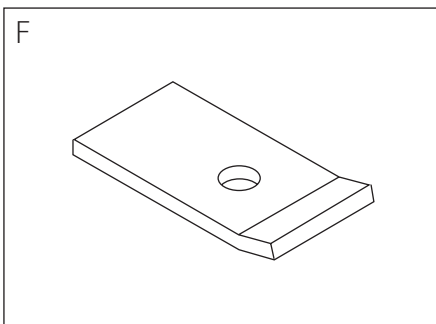
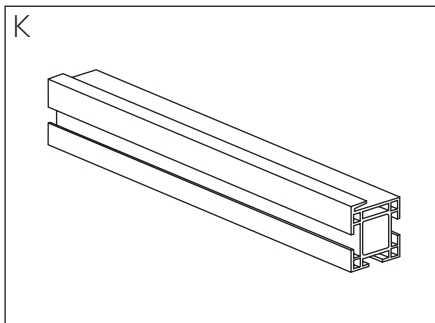
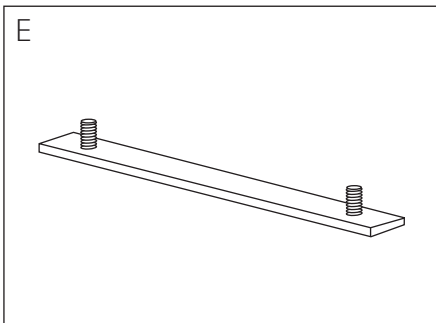
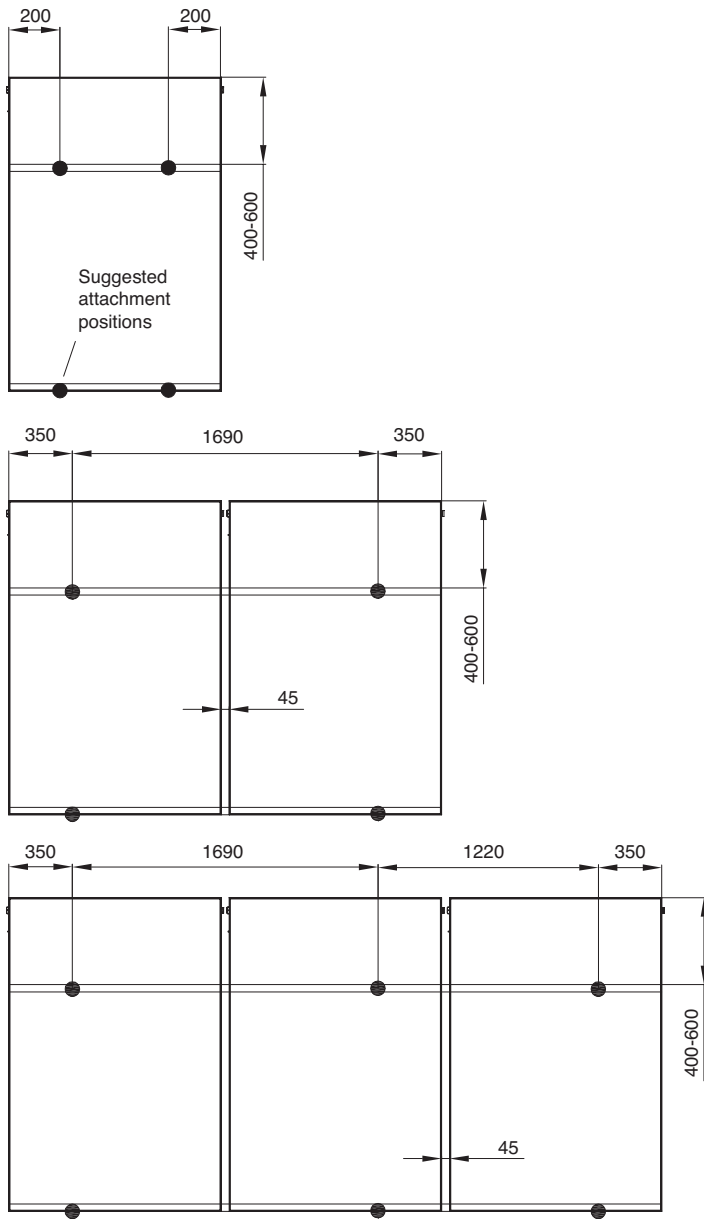

Fig. 4



All dimensions shown in mm

## 2.0 Installation of solar collector

### 2.4 Suggestion for attachment points

NOTE: Some variation may be necessary depending on the pitch of the roof tiles selected.

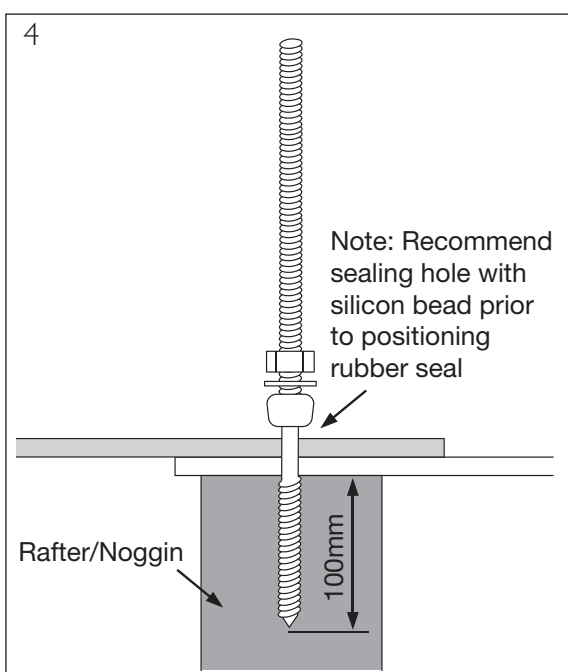
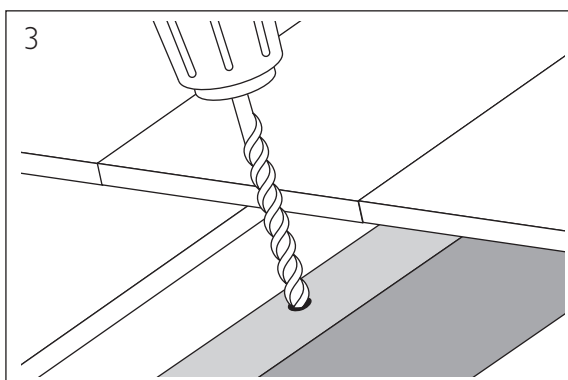
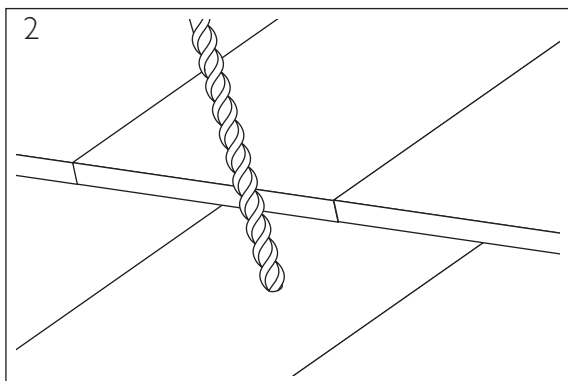
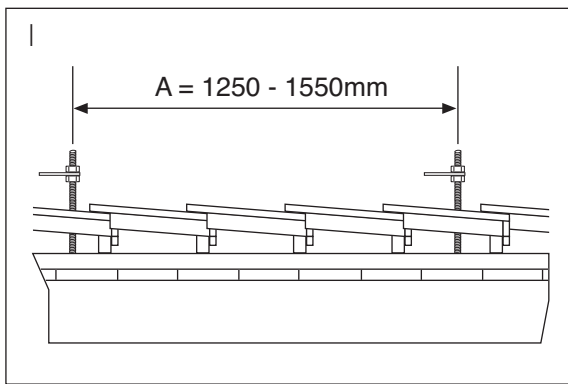

## 2.0 Installation of solar collector

### 2.5 FLAT TILE Mounting system, parallel

- 1: Measure the mounting points (for suggested positions see 2.4), remove appropriate roof tiles.
- 2: Drill tiles using  $\text{Ø}14\text{mm}$  bit.  
Note: On roofs with corrugated tiles do not drill boreholes in the tile trough.
- 3: Drill into rafter/noggin using  $\text{Ø}8\text{mm}$  bit.
- 4: Fasten bench screw, minimum screw depth  $\geq 100\text{mm}$ . Attach rubber seal and tighten using M12 washer and M12 nut.  
Order:
  - bench screw
  - rubber seal
  - M12 washer
  - M12 nut

Repeat procedure for all mounting points.

**Proceed to step 1 on page 14.**

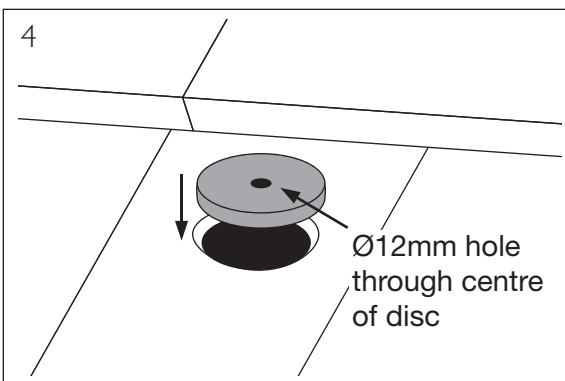
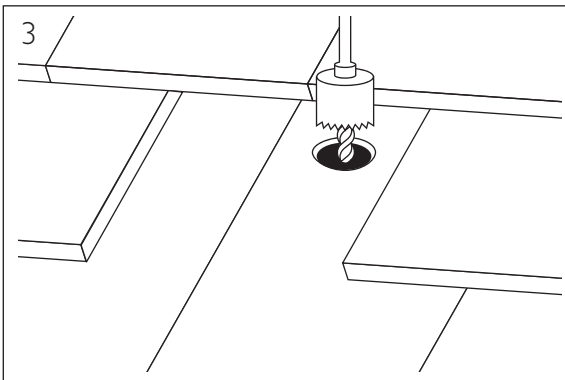
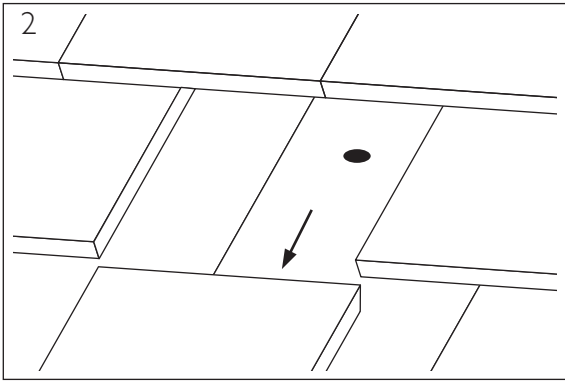
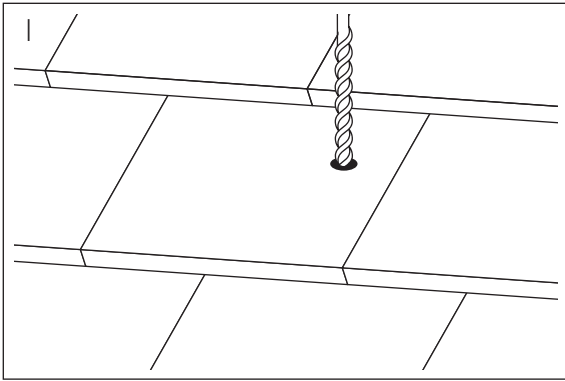
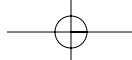

## 2.0 Installation of solar collector

### 2.6 SLATE TILE Mounting system, parallel

1: Drill through slates into rafter using Ø8mm wood bit.

2: Remove top slate and retain to use as template at step 5.

3: Drill Ø50mm hole in underlying slate using hole cutter.

4: Cut Ø50mm disc from weather treated timber to thickness of slate. Insert into previously drilled hole.

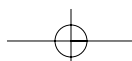
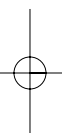
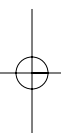

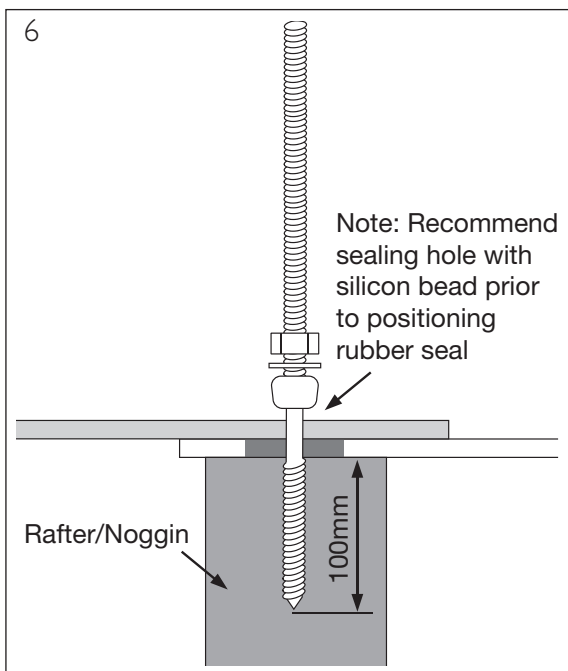
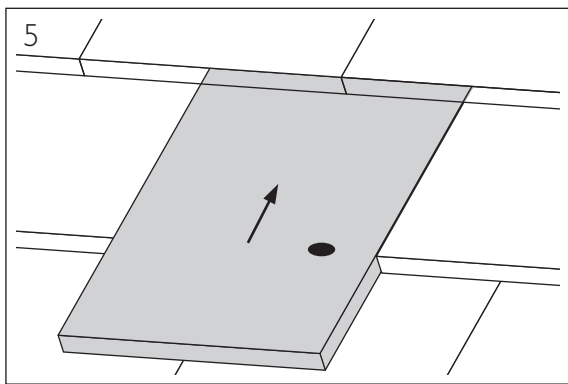

## 2.0 Installation of solar collector

### 2.6 SLATE TILE Mounting system, parallel

5: Create replacement slate from lead/zinc/synthetic tile using previously removed slate as template. Use template to drill  $\text{Ø}12\text{mm}$  hole. Slide into position.

6: Fasten bench screw, minimum screw depth  $\geq 100\text{mm}$ . Attach rubber seal and tighten using M12 washer and M12 nut.

Order:

- bench screw
- rubber seal
- M12 washer
- M12 nut

Repeat procedure for all mounting points.

**Proceed to step 1 on page 14.**

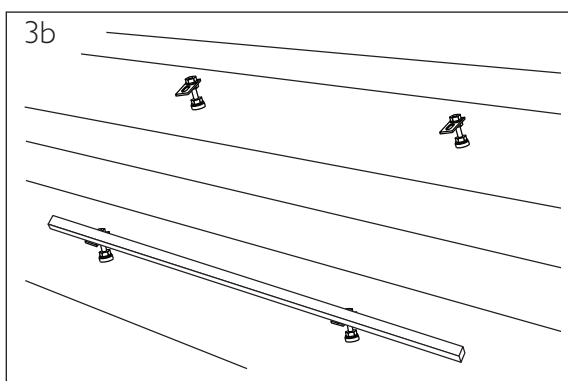
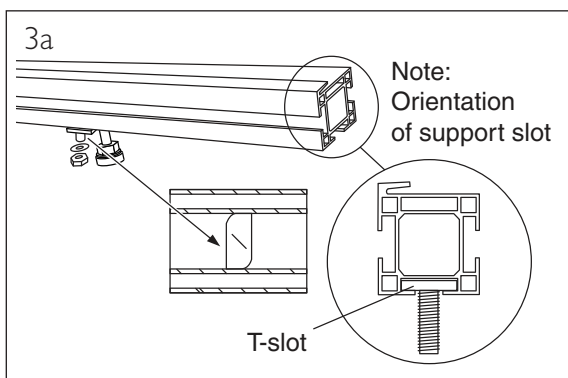
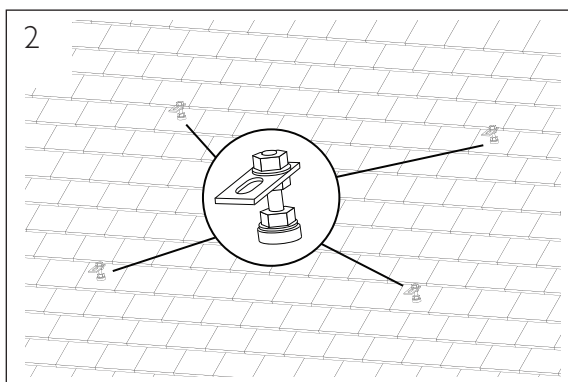
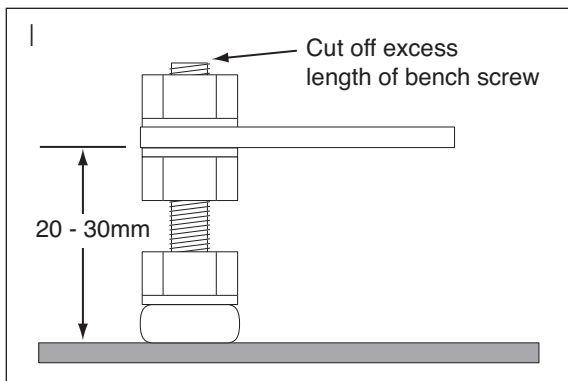

## 2.0 Installation of solar collector

### 2.7

Slate and Flat tile mounting rail system, parallel

**General Note:**  
Points 7-10 and 12-16 of these instructions only apply when mounting two or three collectors.

1: Assemble mounting parts as shown.

- Order:
- M12 nut
  - M12 washer
  - mounting part
  - M12 washer
  - M12 nut

2: Repeat procedure for all mounting points.

3: Attach lower mounting rails as shown in 3a and 3b with the hammer head bolt engaged in the T-slot of the rail.

- Order:
- mounting rail
  - hammer-head bolt
  - mounting part
  - M8 washer
  - M8 nut

Ensure rail is horizontal using a spirit level.

**Note:** for 2 panel systems first join 2 mounting rails together as shown in steps 6 and 7 before attaching to the brackets. Attention must be paid to the correct orientation of the mounting rail to ensure correct panel mounting.

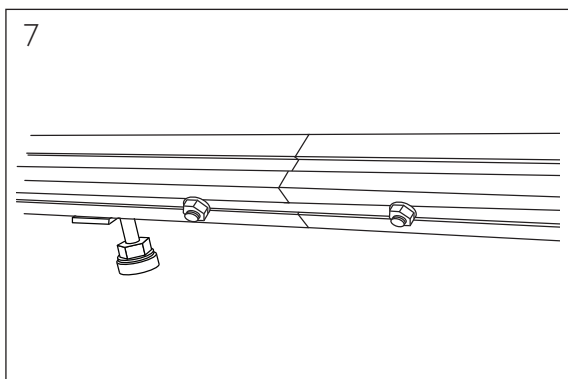
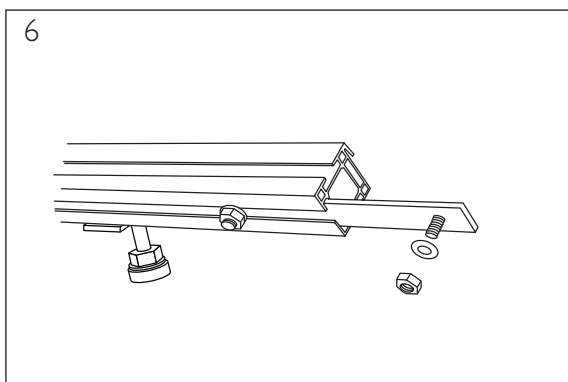
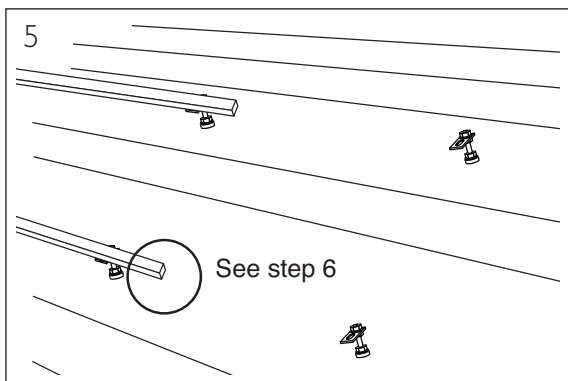
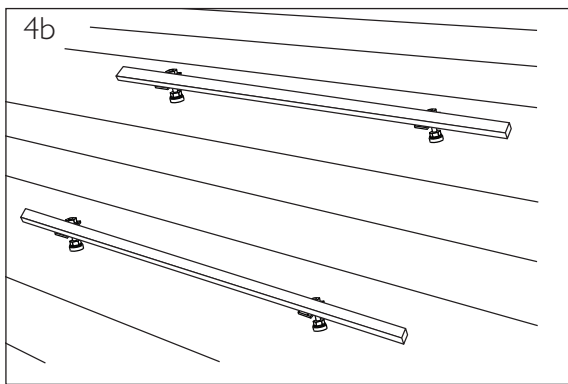
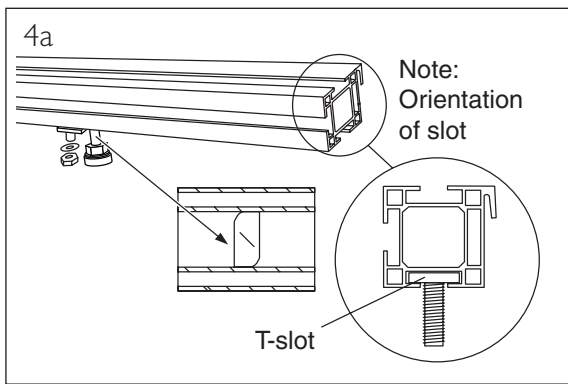

## 2.0 Installation of solar collector

4: Attach upper mounting rail as shown in 4a and 4b.

Order:

- mounting rail
- hammer-head bolt
- mounting part
- M8 washer
- M8 nut

Ensure rail is horizontal using a spirit level.

**Note:** for 2 panel systems first join 2 mounting rails together as shown in steps 6 and 7 before attaching to the brackets. Attention must be paid to the correct orientation of the mounting rail to ensure correct panel mounting.

5: For 3 panel systems join the additional mounting extension as shown in the steps 6 and 7.

6: Push the clamping piece extension halfway into the T-slot of the mounting rails (upper and lower) and tighten.

Order:

- mounting rail
- clamping piece extension
- M8 washer
- M8 nut

7: Insert the additional mounting rails (upper and lower) and attach them using the clamping piece extension

Order:

- mounting rail
- clamping piece extension
- M8 washer
- M8 nut

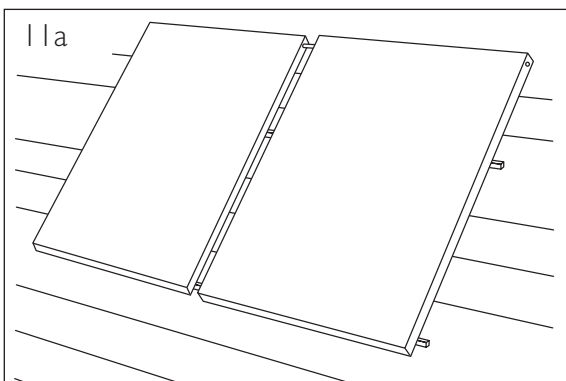
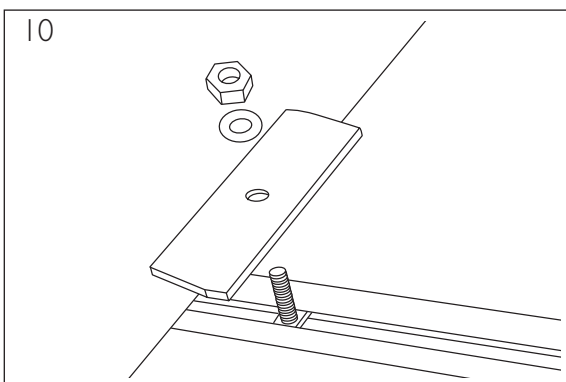
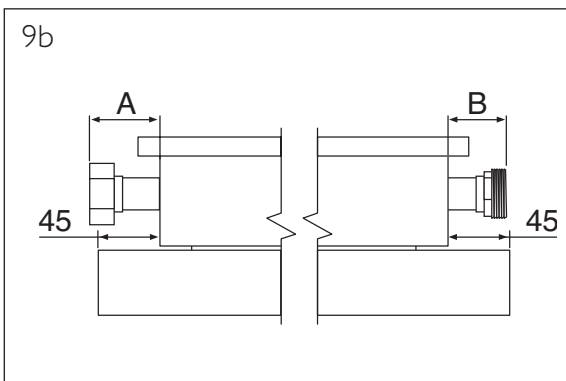
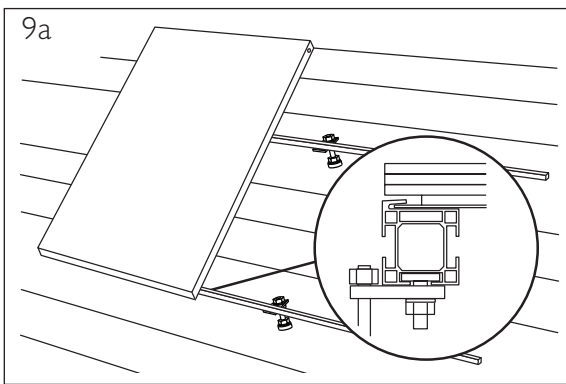
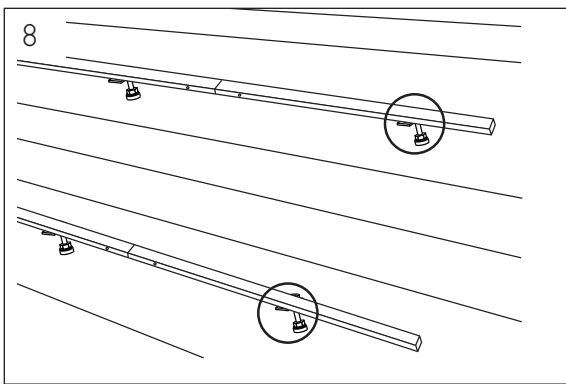

## 2.0 Installation of solar collector

8: Attach the additional mounting rails (upper and lower) to the mounting parts.

Order:

- mounting rail
- hammer-head bolt
- mounting part
- M8 washer
- M8 nut

9: Hang the first collector in the lower mounting rail and adjust its position so that the frame is 45mm from the end of the rail as shown.

N.B. Ensure collector panel locating lip is correctly positioned in the support slot of the lower mounting bracket.

10: If mounting 2 or more panels place the clamping piece on the upper mounting rail and hand tighten for now.

Order:

- upper mounting rail
- mounting part extension
- clamping piece
- M8 washer
- M8 nut

11: Using the mounting jig to aid correct positioning mount the next collector panel. Ensure jig is removed after fitting (see 11b).



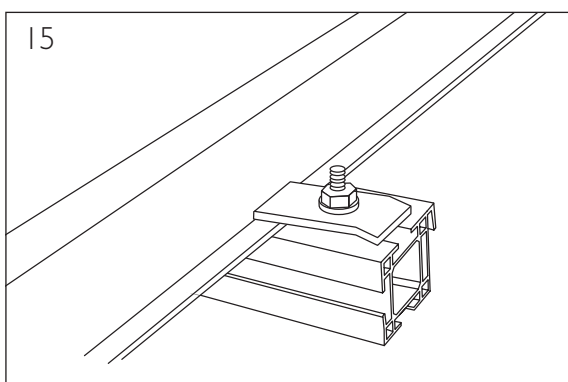
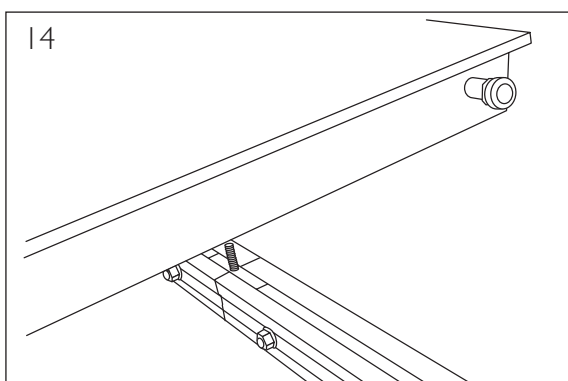
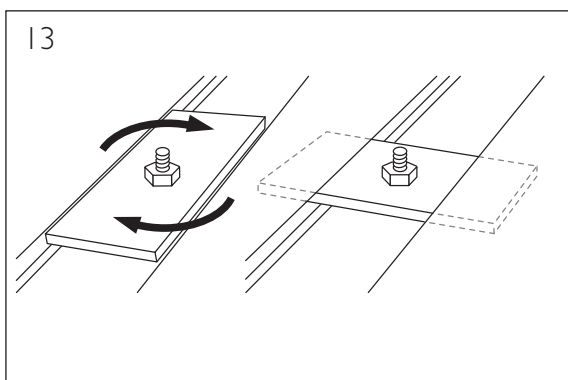
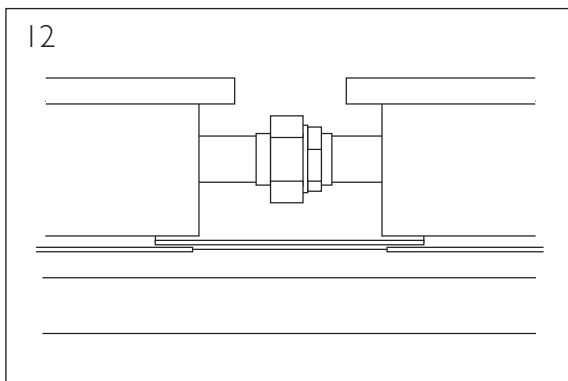
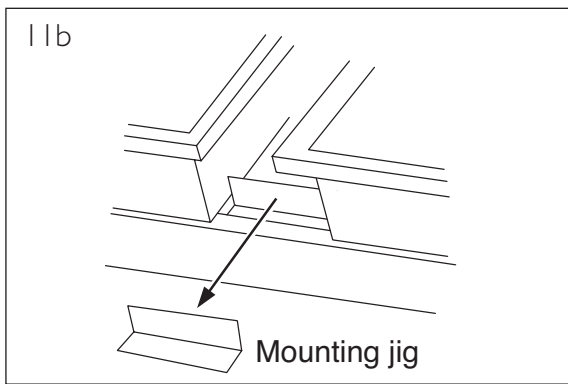

## 2.0 Installation of solar collector

12: Connect the collector panel flow/return pipe together. Ensure the fibre washer is inserted between the male and female connections. Support the pipes when tightening nut.

13: Rotate the clamping piece by 90° so it locates in the Collector panel locating lip and screw it tight using a long socket wrench.

14: Attach additional clamping pieces / collectors as described in points 9-13.

15: Attach the top mounting part on the upper left and right end of the collector.

Order:

- mounting rail
- hammer-head bolt
- top mounting part
- M8 washer
- M8 nut

**2.8** Mounting kit parts list. Profiled tiles

|                             | 1 panel | 2 panels | 3 panels |
|-----------------------------|---------|----------|----------|
| A. Roof bracket             | 4       | 4        | 6        |
| B. Roof bracket console     | 4       | 4        | 6        |
| C. Self-tapping screws 6x60 | 16      | 16       | 24       |
| D. Cup square bolt 8x25     | 4       | 4        | 6        |
| E. M8 hex self-securing nut | 4       | 4        | 6        |
| F. Clamping piece           | -       | 1        | 2        |
| G. Clamping piece extension | -       | 2        | 4        |
| H. Mounting part, top       | 2       | 2        | 2        |
| I. Mounting part extension  | -       | 1        | 2        |
| J. M8 washer                | 6       | 11       | 18       |
| K. M8x30 hammer-head bolt   | 6       | 6        | 8        |
| L. M8 hex nut               | 6       | 11       | 18       |
| M. Support rail             | 2       | 4        | 6        |
| N. Mounting jig             | -       | 1        | 1        |
| O. Sealing washer           | 2       | 3        | 4        |

**NOTE:** 1 sealing washer is supplied with each solar collector panel. 2 sealing washers are supplied with the flexible connection pipes.

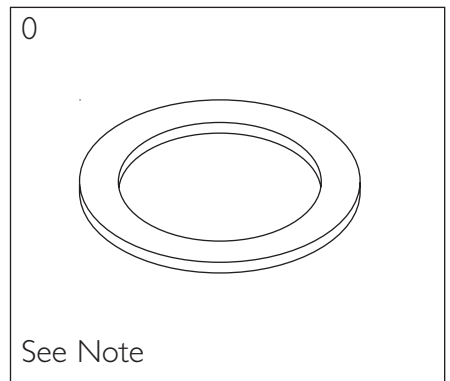
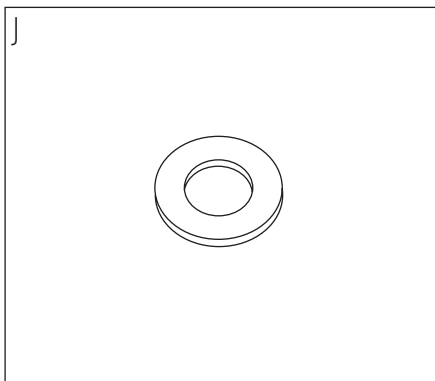
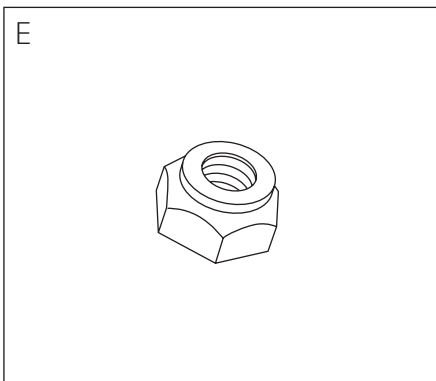
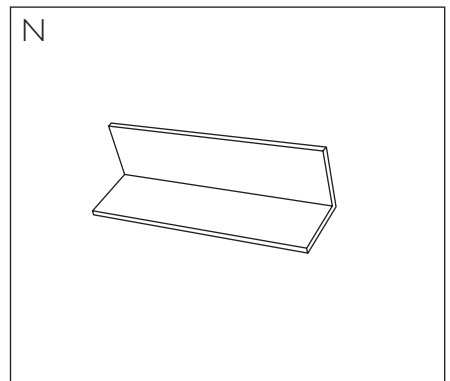
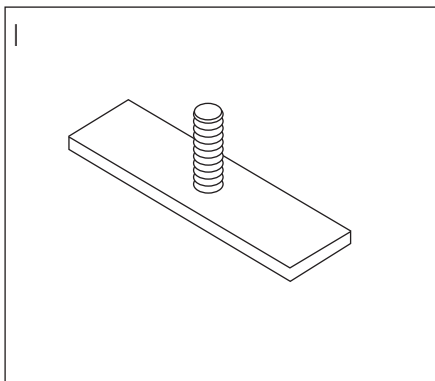
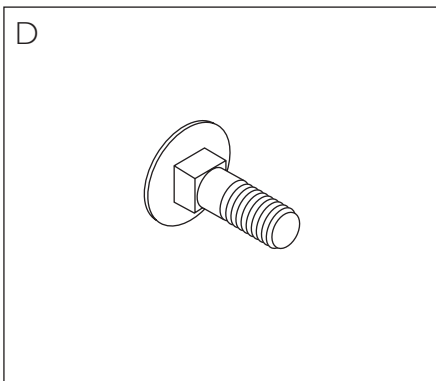
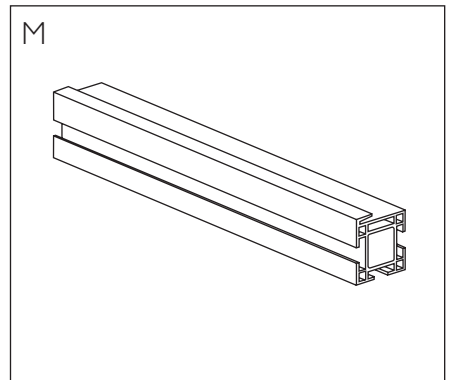
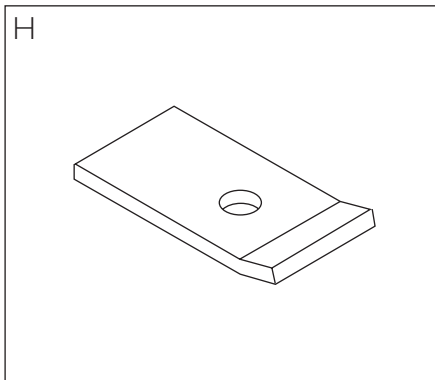
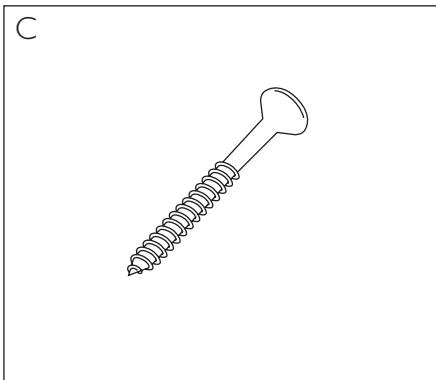
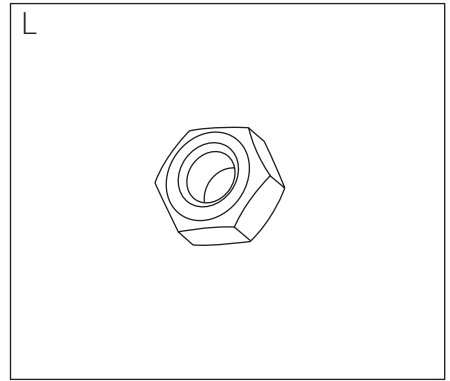
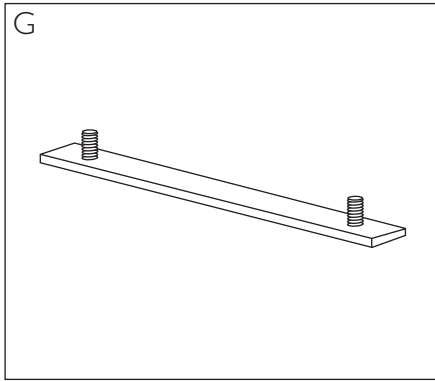
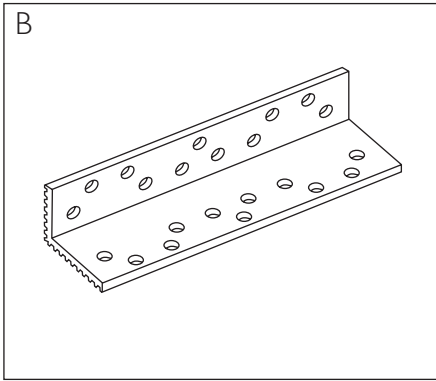
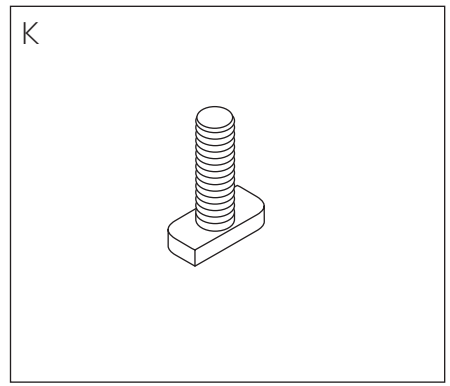
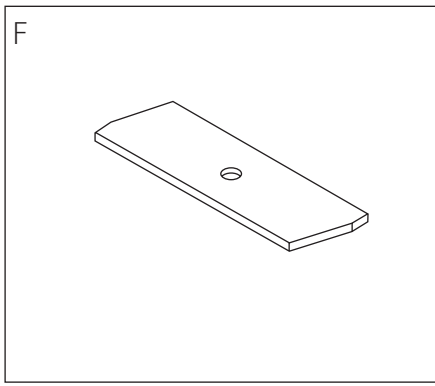
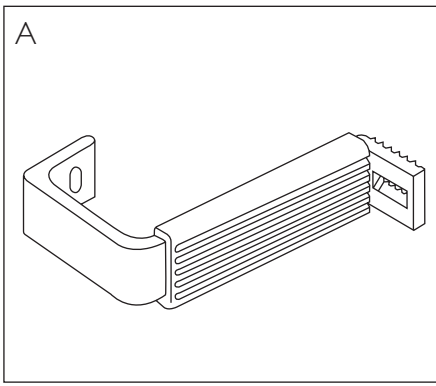
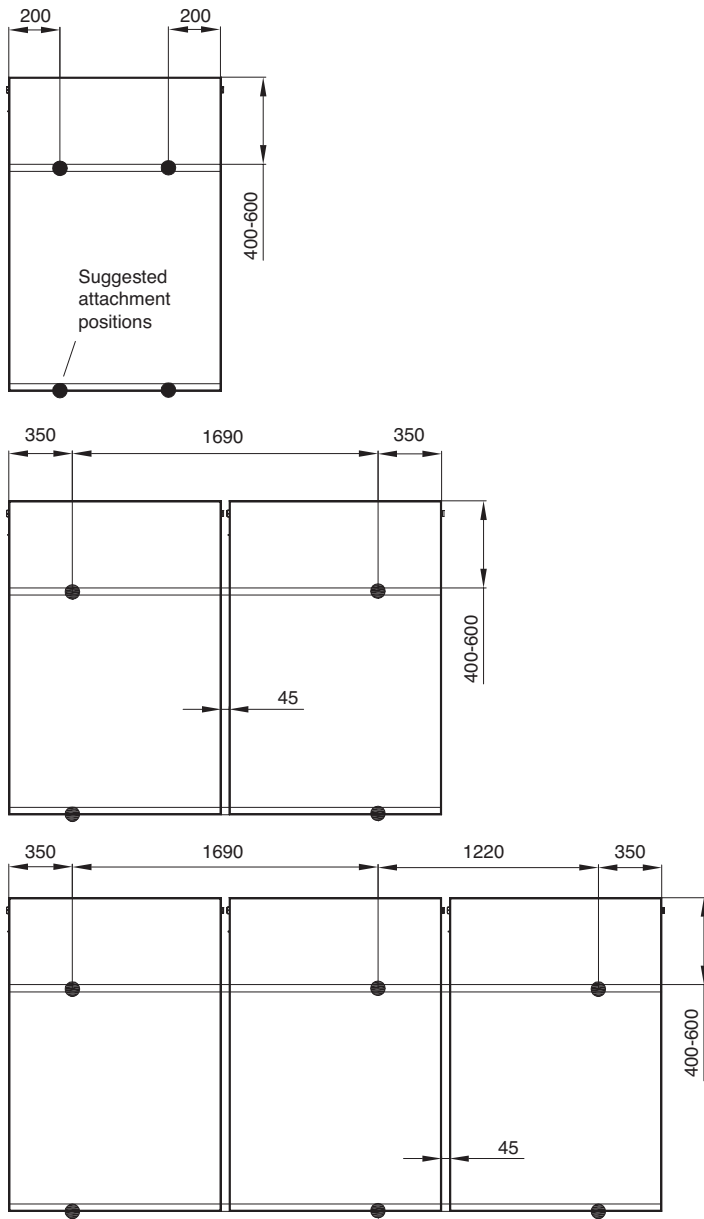

Fig. 5



All dimensions shown in mm

## 2.0 Installation of solar collector

### 2.9 Suggestion for attachment points

NOTE: Some variation may be necessary depending on the pitch of the roof tiles selected. Roof hook must always sit in the lowest part of tile profile.

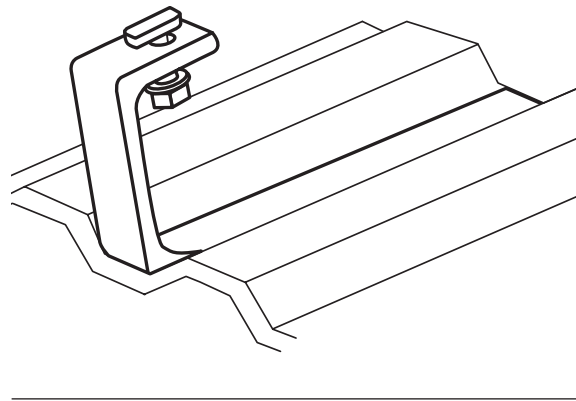

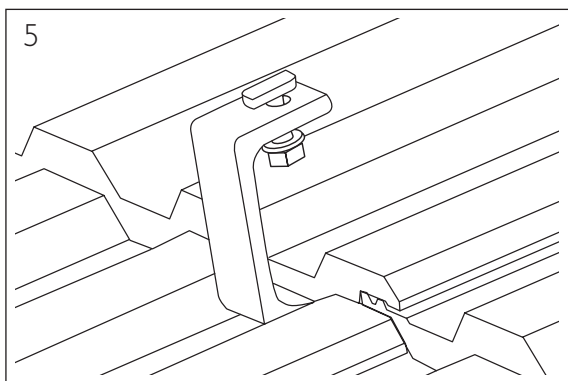
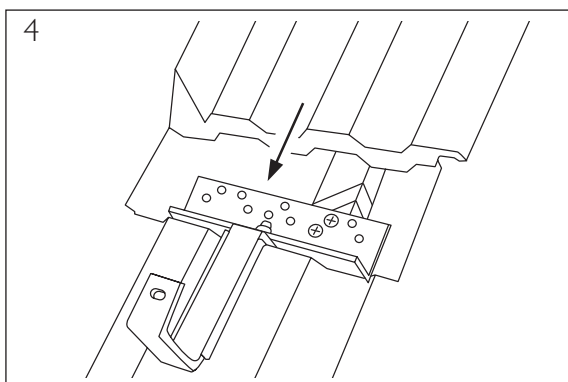
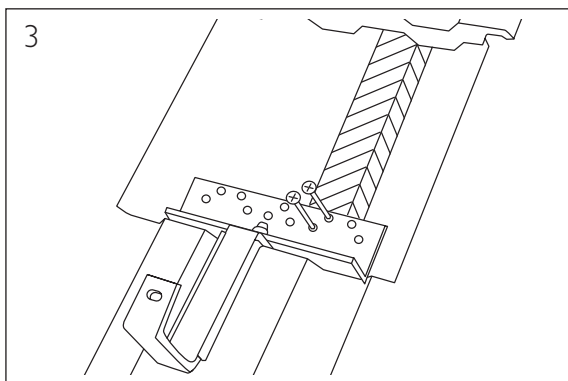
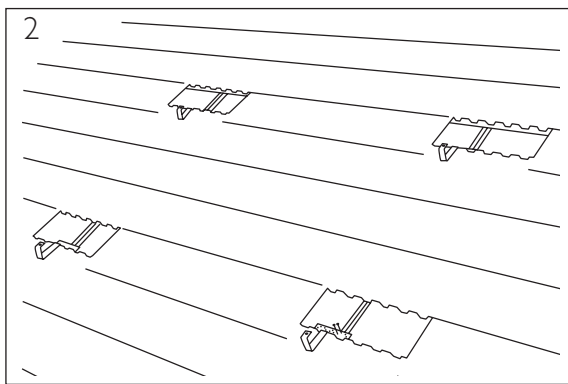
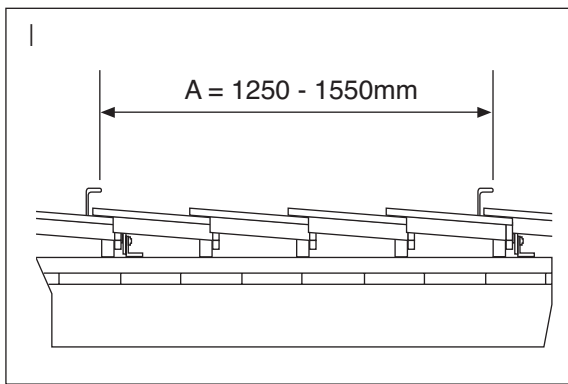

## 2.0 Installation of solar collector

### 2.10 Profiled tile mounting system, parallel

#### General Note:

Points 8-11 and 13-17 of these instructions only apply when mounting two or three collectors.

- 1: A = 1250 - 1550mm
- 2: Measure the mounting points (for suggested positions see 2.9), remove appropriate roof tiles.
- 3: Loosely connect the roof brackets to the roof bracket consoles using the cup square bolts and M8 self securing nuts. Position over the tile, adjust height between bracket and bracket console and attach bracket console to the roof structural member or noggin using 2 off 6x60 self tapping screws. Tighten M8 self securing nuts.
- 4: Slide the previously removed roof tiles over the brackets. The roof tiles may be ground down for a better fit if necessary.
- 5: Insert the hammer-head bolt into the external slot of the roof bracket fit M8 nut and washer and hand tighten for now.

Order:

- hammer-head bolt
- mounting bracket
- washer
- nut as shown

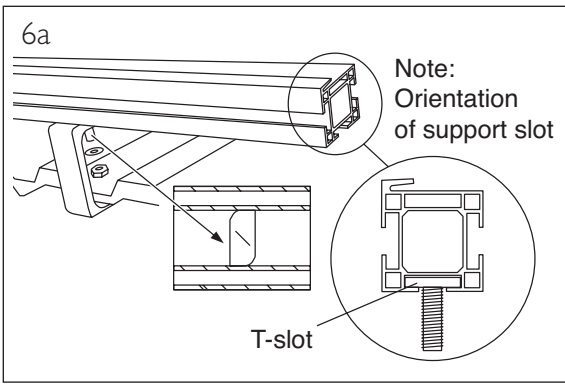

## 2.0 Installation of solar collector

6: Attach lower mounting rails as shown in 6a and 6b with the hammer head bolt engaged in the T-slot of the rail.

Order:

- mounting rail
- hammer-head bolt
- roof bracket
- washer
- nut

**Note:** for 2 panel systems first join 2 mounting rails together as shown in steps 9 and 10 before attaching to the brackets. Attention must be paid to the correct orientation of the mounting rail to ensure correct panel mounting.

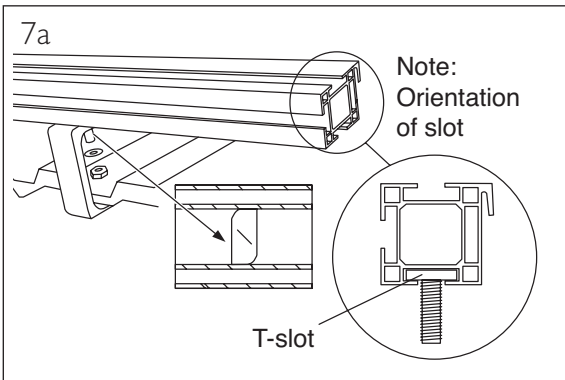
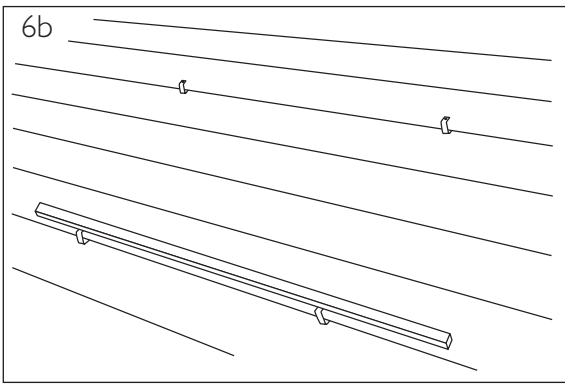

7: Attach upper mounting rail as shown in 7a and 7b.

Order:

- mounting rail
- hammer-head bolt
- roof bracket
- washer
- nut

**Note:** for 2 panel systems first join 2 mounting rails together as shown in steps 9 and 10 before attaching to the brackets. Attention must be paid to the correct orientation of the mounting rail to ensure correct panel mounting.

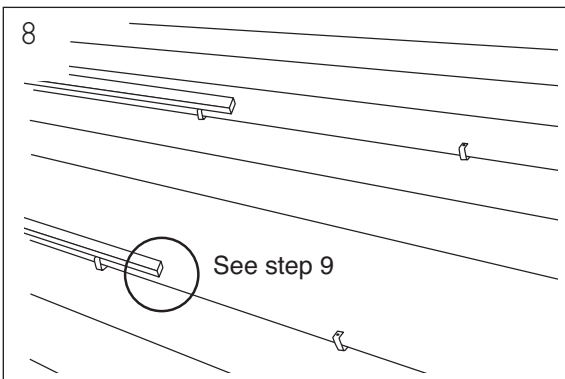
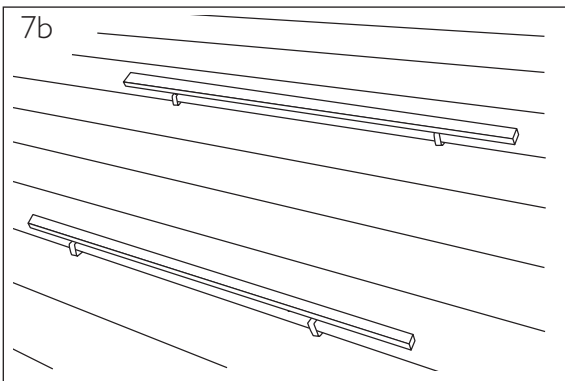

8: For 3 panel systems join the additional mounting extension as shown in the steps 9 and 10.

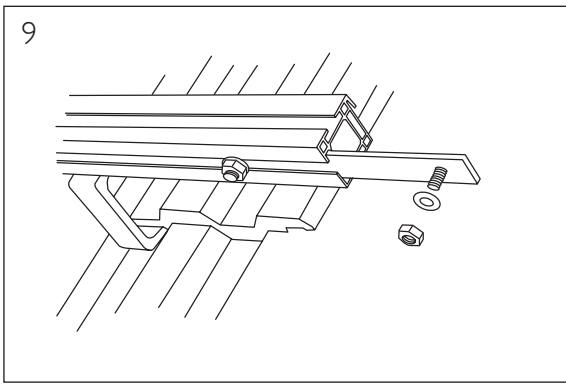

## 2.0 Installation of solar collector

9: Push the clamping piece extension halfway into the T-slot of the mounting rails (upper and lower) and tighten.

Order:

- mounting rail
- clamping piece extension
- washer
- nut

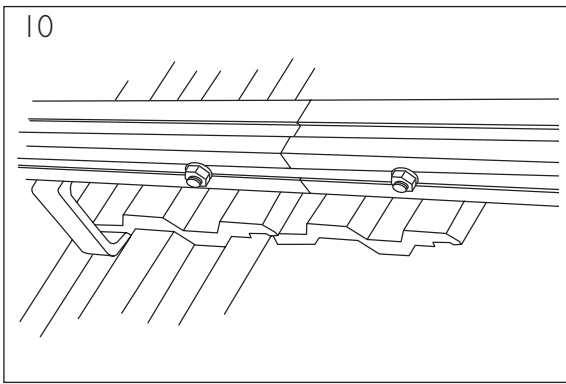

10: Insert the additional mounting rails (upper and lower) and attach them using the clamping piece extension

Order:

- mounting rail
- clamping piece extension
- washer
- nut

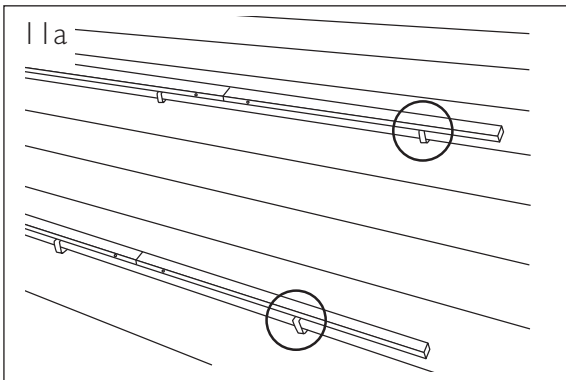

11: Attach the additional mounting rails (upper and lower) to the roof brackets.

Order:

- mounting rail
- hammer-head bolt
- roof bracket
- washer
- nut

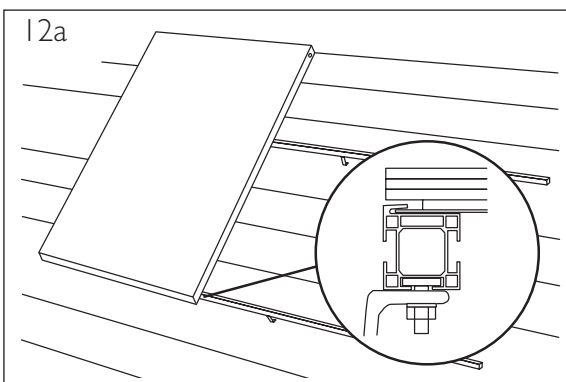

12: Hang the first collector in the lower mounting rail and adjust its position so that the frame is 45mm from the end of the rail as shown.

N.B. Ensure collector panel locating lip is correctly positioned in the support slot of the lower mounting bracket.

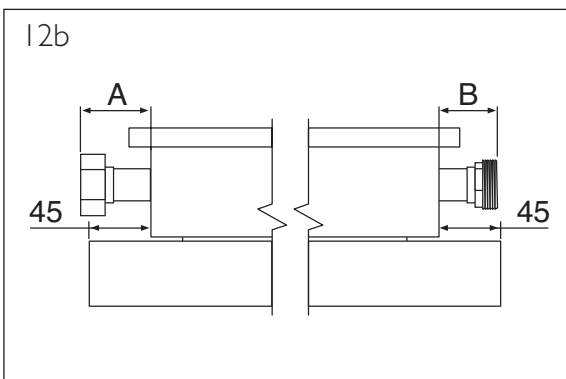

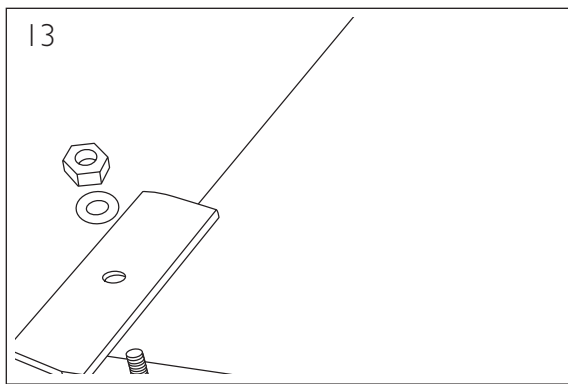

## 2.0 Installation of solar collector

13: If mounting 2 or more panels place the clamping piece on the upper mounting rail and hand tighten for now.

Order:

- upper mounting rail
- mounting part extension
- washer
- clamping piece
- washer
- nut

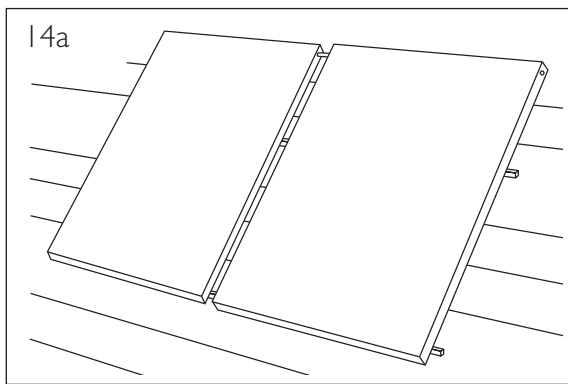

14: Using the mounting jig to aid correct positioning mount the next collector panel. Ensure jig is removed after fitting (see 14b).

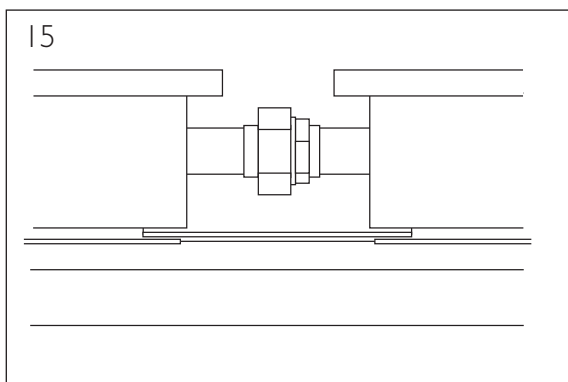
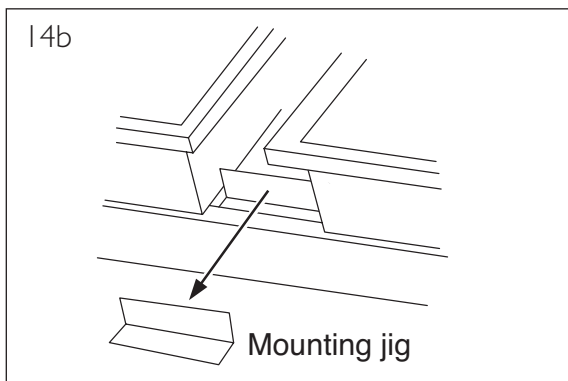

15: Connect the collector panel flow/return pipe together. Ensure the fibre washer is inserted between the male and female connections. Support the pipes when tightening nut.

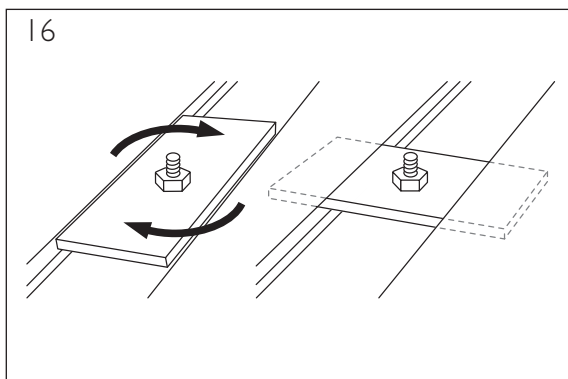

16: Rotate the clamping piece by 90° so it locates in the Collector panel locating lip and screw it tight using a long socket wrench.



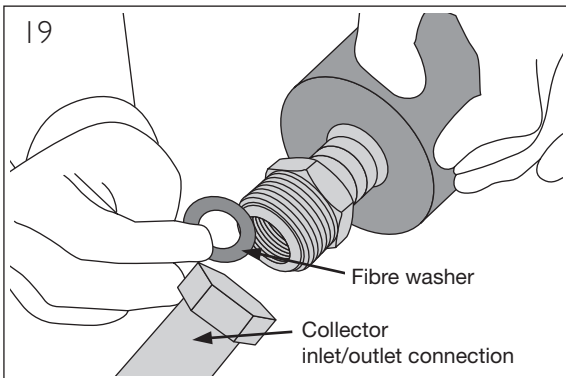
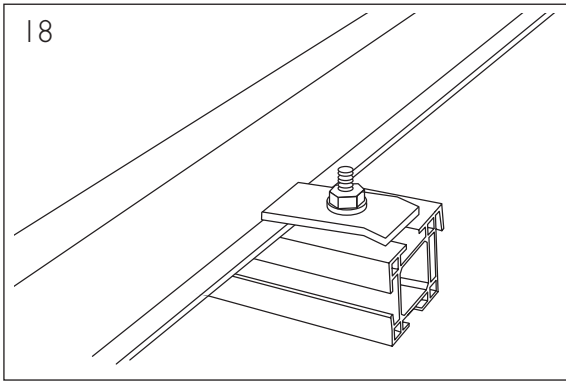
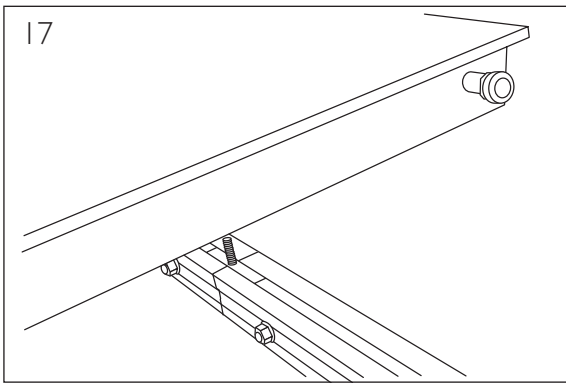

## 2.0 Installation of solar collector

17: Attach additional clamping pieces / collectors as described in Points 12-16.

18: Attach the top mounting part on the upper left and right end of the collector.

Order:

- mounting rail
- hammer-head bolt
- top mounting part
- washer
- nut

19: Connect flexible connection pipes to collector panel inlet and outlet connections. Ensure fibre washer is used between connection pipe and connections.

Fig. 6

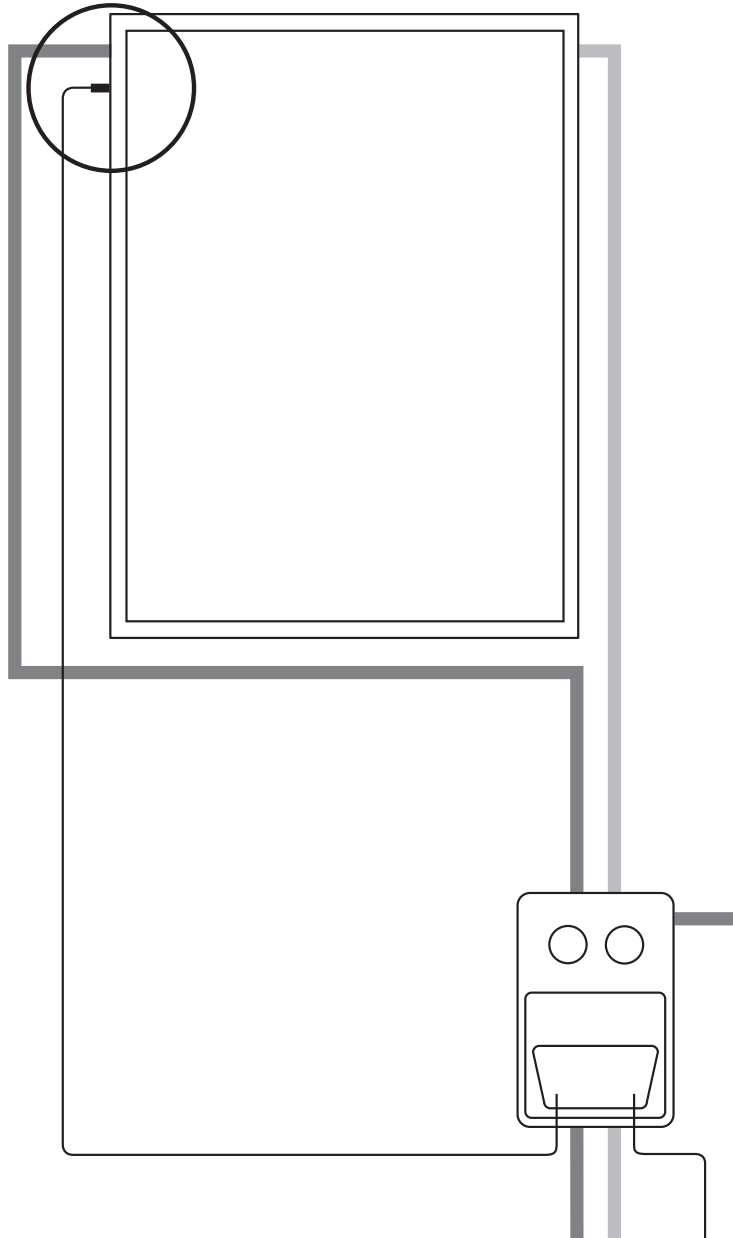

### 3.0 Installation of collector panel sensor

The Collector panel temperature sensor should be installed in the sensor pocket nearest to the collector array flow. It should be secured in the pocket by inserting through the rubber gland provided. All materials used for installing temperature sensors (sensor element, conducting compound, cables, sealing and insulating materials) must be suitably temperature resistant (up to 250°C).

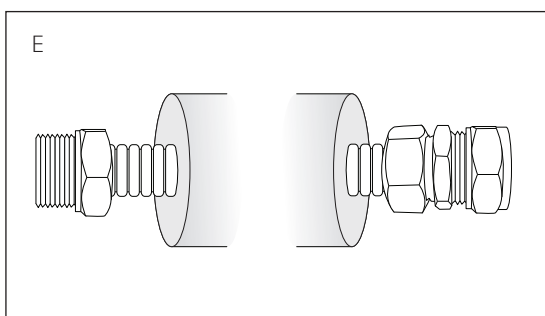
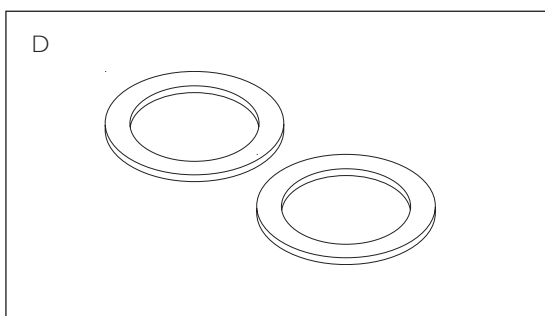
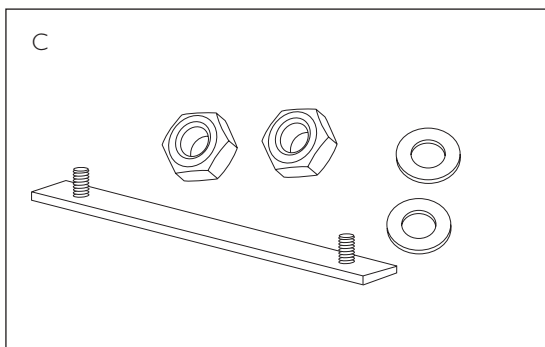
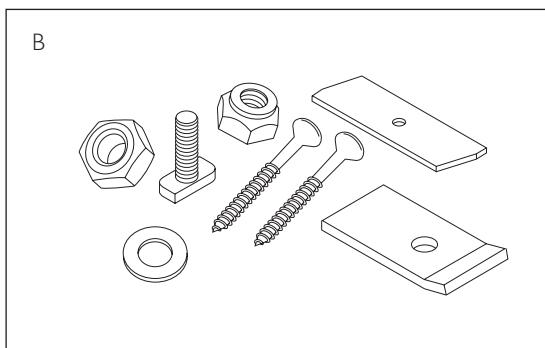
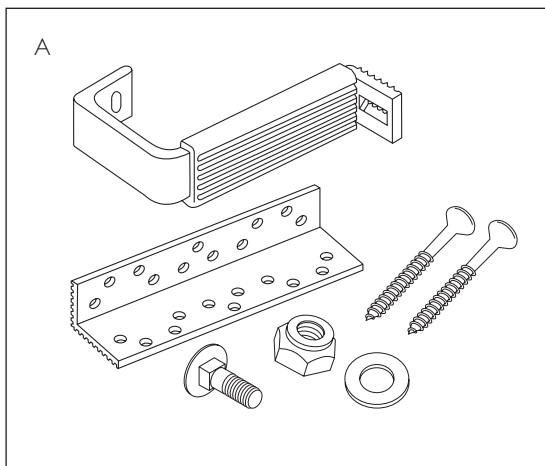

## 4.0 Spares

### 4.1 Spare parts

A number of Spare Parts are available should any part of the Solarflo system require replacement. Use only genuine parts obtained from Baxi, use of other non Baxi parts may cause system malfunctions and will invalidate the warranty. Fitting of any spare parts must be carried out by a competent installer or authorised service engineer or agent.

| Description   | Code No. |
|---|----------|
| <b>A Roof bracket assembly</b><br>(comprising roof bracket, roof bracket console, cup square bolt M8 x 25, M8 washer, M8 hex self securing nut and 2 off self tapping screws No6 x 60 long)                                 | 5119532  |
| <b>B Collector panels fixings kit</b><br>(comprising 2 off No6 x 60 self tapping screws, cup square bolt M8 x 25, M8 washer, M8 hex nut, M8 self securing nut, M8 x 30 hammer head bolt, mounting part top, clamping piece) | 5119533  |
| <b>C Extension assembly</b><br>(comprising clamping piece extension, mounting part extension, 2 off M8 hex nut, 2 off M8 washer)  | 5119534  |
| <b>D Connection washer</b><br>(comprising 2 off flat sealing washer)  | 5119535  |
| <b>E Connection hoses and insulation</b>  | 5122982  |

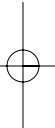
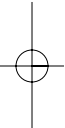
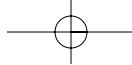

All descriptions and illustrations provided in this leaflet have been carefully prepared but we reserve the right to make changes and improvements in our products which may affect the accuracy of the information contained in this leaflet. All goods are sold subject to our standard Conditions of Sale which are available on request.

**BAXI**

A Trading Division of Baxi Heating UK Ltd, a division of Baxi Group.

Brooks House, Coventry Road, Warwick. CV34 4LL

After Sales Service and Technical Enquiries 08700 603261

Our contact centre is open Monday to Friday 8am to 6pm,  
Weekends and Bank Holidays 8.30am to 2pm.

We are closed Christmas Day and New Years Day.

Website [www.baxi.co.uk](http://www.baxi.co.uk)

Comp No 3600 5977 - Issue 1 - 5/07

A division of **BAXI GROUP**

