

Baxi Bermuda high efficiency  
Back Boiler Unit with Valor  
Dimension™ Firefront

A >90%



# The next generation Baxi Bermuda Back Boiler Unit



Gas Industry  
Innovation Award 2010



Baxi's commitment to innovation, technology and excellence has defined the company since 1866. Creating efficient heating and hot water solutions is all we think about. It's the reason we're always one step ahead and able to create products that meet your needs.

The original Baxi Bermuda Back Boiler Unit (BBU), launched in 1966, was so practical and reliable that Baxi installations accounted for 80% of the back boilers installed in the UK. Times changed and so did boilers, but with the introduction of our innovative new Bermuda BBU HE we continue our tradition of back boiler expertise. As the only high efficiency BBU in the UK, it's the easiest way to replace an existing BBU.



An integral part of a BBU solution is the Valor Dimension™ range of fires. Valor fires have been keeping millions of homes warm and cosy since our initial production of portable oil heaters in 1902. Outstanding technological developments and continual investment in product design have ensured Valor remain at the forefront of the heating industry.

Part of the Baxi Group and one of the largest UK manufacturers of electric fire products, Valor produce

a range that includes traditional and contemporary styles, from stand-alone units to suites and surrounds. Together with Baxi boilers, they provide a complete heating package.

## Package Details

Baxi Bermuda BBU HE	p 3,8 & 9
Valor Dimension™ BBU Range of Firefronts	p 4 - 6
Flue Kits & Installation	p 10 - 11

## Optional Extras

Marble Back Panel and Hearths	p 6
Surround Sets/Surrounds	p 7 & 12
Boiler Accessories	p 9
Flue Pull Cone	p 10
Spacers and Rebated Surrounds	p 13

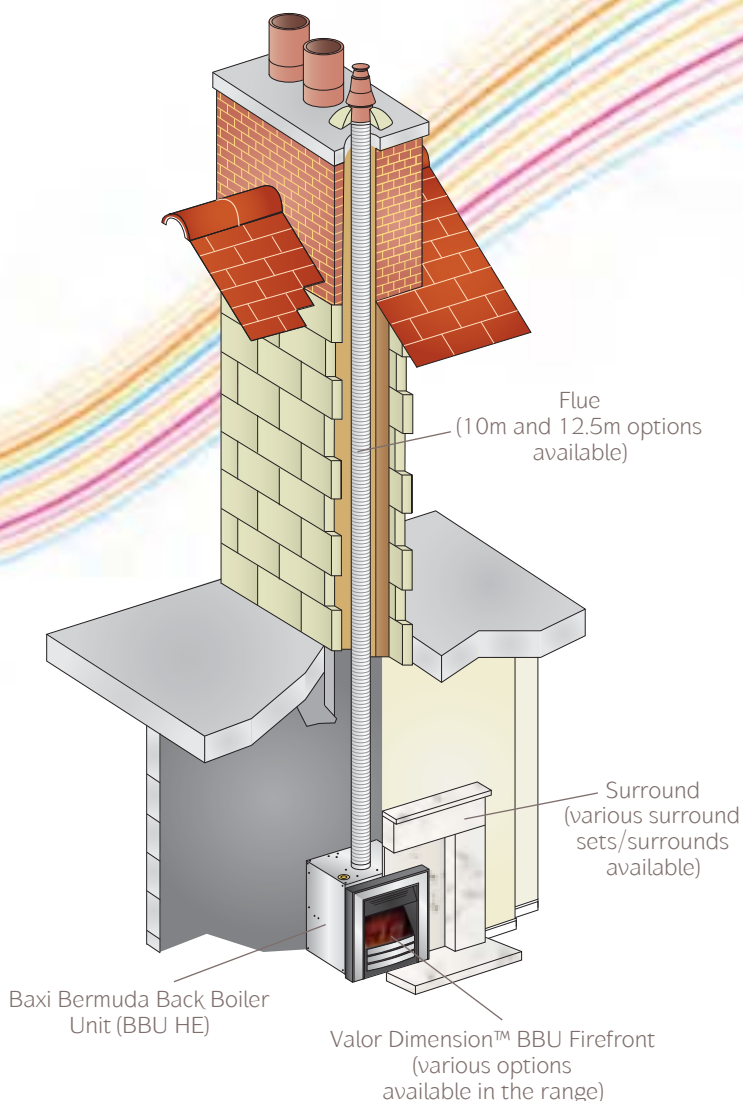

## Key features and benefits

- Trusted, reliable Baxi back boiler technology, for complete peace of mind
- High efficiency back boiler, meeting all current legislation
- SEDBUK Band A rated, saves energy and reduces heating bills
- 15kW heat output; modulating boiler adapts to heat demand ensuring optimum performance at all times
- Room sealed appliance; eliminating the need for air vents in the room
- Built in condensate pump and no pump overrun required, to ease installation
- Factory set to enable easy boiler commissioning
- Simple to use external boiler controls located on the dedicated Valor Dimension™ firefront
- Single piece flexible concentric flue; eliminates the need to provide flue inspection access
- 2 year warranty \*
- Quiet in operation

**A** >90%

\*Subject to registration and an annual service

# Easy to fit, efficient to run

## Benefits of replacing an old BBU with a Baxi Bermuda BBU HE

- The simplest, most convenient way to replace a BBU
  - No need to re-site the boiler and modify the pipe work
  - No loss of valuable kitchen cupboard space
  - No major disruption or redecoration to the property
  - The only like-for-like replacement in the UK
- It's the only high efficiency BBU in the UK
  - Fully compliant with Building Regulations Part L
  - Saves energy – replacing an old boiler can save up to a quarter on an annual fuel bill \*

\*Energy Saving Trust, August 2009





# Valor Dimension™ BBU HE Range



Valor Dimension™ Regalia with Olympia Surround  
Featured on Front Cover Valor Dimension™ Dream with Clarissa Oak Surround

## Give your fireplace a new dimension with the Valor Dimension™ range of fires

The Baxi Bermuda BBU HE has been specifically designed to work with the Valor Dimension™ range of BBU Firefronts. The new Dimension™ range of electric Firefronts from Valor uses cutting edge technology to create the world's most authentic 'real fire effect'. Redefining the market for fuel effect electric fires, the Valor Dimension™ range offers both traditional and contemporary styles, backed by the quality, reliability and peace of mind you would expect from the leading

name in home heating. It's a totally new way of enjoying the atmosphere that only a real fire can create – all at the press of a button.

### Key features and benefits

- Revolutionary, patented fuel bed, with 'real fire effect'
- Traditional and contemporary fire front designs
- Running costs for the fire using the 'effect', are less than 2p per day
- Heat outputs of 1kW and 2kW
- No servicing required
- The BBU firefront range is a unique range dedicated to the Baxi Bermuda Back Boiler Unit package

# A 'real fire effect' that makes a real statement



## Nano

Nano's sleek stylish appeal and clean lines allow the innovative Dimension™ effect to take centre stage. The generous profile of the inset inlays perfectly frame the full depth 'real fire effect' to create a modern and sophisticated style.



## Regalia

Designed with total attention to detail the Regalia has been created to reflect an original style Victorian arch fireplace. Its elegant contours make a statement that is neither fussy nor flamboyant and will form a natural centrepiece to any room.



## Innova

Whether it's switched on or off the Innova fire makes a style statement. The elegant glass and silver design, combined with 'real fire effect' technology, creates an extraordinary focal point for any room. Innova can be wall mounted or hearth mounted.



## Lyrica

The Lyrica design is inspired by traditional firedogs and incorporates them into a free-standing fret design. It creates an imposing feature that establishes a sense of tradition without intricate detailing.

# Discover the beauty of Valor fires



## Dream

From its solid cast iron fascia with plating, to the faithful finishing and hand craftsmanship, Dream's high quality showcases timeless beauty along with Valor's cutting edge technology.

## Classica

The Classica combines a traditional solid cast iron fascia with authentic hand finishing and honest materials, to create a design that is both modern and simple.

# Solo-Pro Back Panel and Hearth

Match your choice of fire and surround with a back panel and hearth. The back panel fills the space between the fire and surround whilst the hearth is positioned on the floor to support the fire surround.



BLACK GRANITE



CREAM MICRO MARBLE

WHITE MICRO MARBLE

Revolutionary new Solo-Pro marble or granite solution on a lightweight frame provides a hearth and back panel that is 70% lighter and 80% stronger than bonded marble. It looks stunning and can be fitted simply and quickly without the need for expert help. It can expand for use with 405mm (16") or 450mm (18") fireplace openings and is available in black granite, cream or white micro marble.

 Can be remote controlled

# Stylish surroundings for any home

Choose the perfect design to complement your choice of fire. Select a surround and match it to a back panel and hearth or find a surround that comes with back panel and hearth included. Rebated surrounds are available for properties where the chimney space cannot accommodate the BBU HE and the Valor Dimension™ fire engine. Please see page 13 for details.



MAHOGANY

## Medway Surround Set

The Medway provides the quality of a real wood veneer surround and hearth, while the fully assembled surround sets, which come complete with hearth and backpanel, save time on installation. A 75mm (3") rebate ensures additional space is available for the fire rear where required.

Finishes also available in



OAK

## Calista Surround

The Calista comes in four easy to assemble pieces and the 150mm (6") rebated Oak version ensures additional space is available for the fire rear where required. The Calista is also supplied with fixing strips for Solo-Pro back panels and hearths.

Finishes also available in



MAPLE

## Teviot Surround Set

The Teviot provides the quality of a real wood veneer surround and hearth, while the fully assembled surround sets, which come complete with hearth and backpanel, save time on installation. A 75mm (3") rebate ensures additional space is available for the fire rear where required.

Finishes also available in



## Clarissa Surround

Understated elegance in an Oak finish, the Clarissa comes in four pieces for ease of installation, and is supplied with fixing strips for Solo-Pro back panels and hearths.



## Olympia Surround

Olympia's classic design can be used in both period and modern interiors. It's a revolutionary lightweight marble solution that comes in cream micro marble veneer and three easy to assemble pieces.



## Barcelona Surround

A revolutionary lightweight granite solution that provides the height of contemporary style. The Barcelona comes in a natural granite veneer and three easy to assemble pieces. A 150mm (6") rebated version is available to provide additional space for the fire rear where required.



# BBU HE Technical Specification

The 3D diagram below displays the key components of the Baxi Bermuda BBU HE.

- |  |                                 |
|--|---------------------------------|
| 1. Automatic Air Vent                              | 11. Fan                         |
| 2. Flue Connection                                 | 12. Drain                       |
| 3. Spark Generator (located behind PCB)            | 13. Return Connection           |
| 4. Spark & Sensing Electrodes (located behind PCB) | 14. Air Sampling Point          |
| 5. Heat Exchanger (located behind PCB)             | 15. Flue Sampling Point         |
| 6. User Interface Connector                        | 16. Flow Connection             |
| 7. Control Wiring Connector                        | 17. Condensate Outlet           |
| 8. Condensate Sump                                 | 18. PCB Control Box             |
| 9. Gas Cock  | 19. Boiler Control (cover open) |
| 10. Condensate Pump                                |                                 |





Baxi Bermuda BBU HE		
<b>CONTROLS</b>		
Boiler	Sales Code	710153301
Concealed User Controls		Yes
User Adjustable CH Temperature		Factory Preset
LED Status/Fault Diagnosis Display		Yes
<b>GAS</b>		
Gas Supply Pipe Size	mm	15mm compression
Natural Gas		Yes
LPG (Butane/Propane)		No
Nominal Inlet Supply Pressure	m <sup>3</sup> /hr	20
Maximum Gas Rate		1.63
Heat Input Central Heating	kW Max Gross kW Max Net	17.1 15.38
Heat Output CH Non Condensing	kW Max	15
Heat Output CH Condensing	kW Max	15.7
Seasonal Efficiency	%	90.1
SEDBUK Rating	Band	A
Nox Class		5
Nox Levels	mg/kWh	31
<b>ELECTRICAL</b>		
Electrical Supply	Volts/Hz	230/50Hz
Permanent Live Required		Yes
Electrical Cable Required		4 core wire
Power Consumption	Watts	112
External Fuse Rating	Amps	3
Internal Fuse Rating	Amps	3.15
Ingress Protection Rating		IPX0
Pump Overrun		not required
<b>MECHANICAL &amp; HYDRAULIC</b>		
Compartment Ventilation Required		No
Flow & Return Pipe Size	mm	22 male copper
Condensate Discharge Pipe Connection	mm	10
Bypass Required		Yes (pressure operated)
Vertical Pipe Route		no inverted pipework permitted
CH System Inhibitor Required		Yes
<b>CONCENTRIC FLUE SYSTEM</b>		
Outside Diameter	mm	100
Max Equivalent Length Vertical	m	10 or 12.5
<b>WEIGHTS</b>		
Max Installer Lift Weight	kg	27
Gross Packaged Boiler Weight	kg	28
<b>ACCESSORIES</b>		
Right Hand Plumb Kit	Sales Code	720111701

## Boiler dimensions

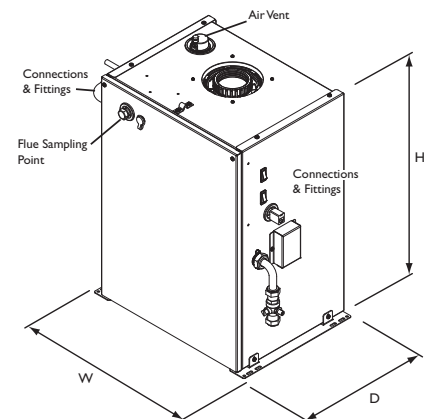

W (Width) = 430mm including connections & fittings  
 D (Depth) = 330mm including flue sampling point  
 H (Height) = 550mm including air vent

## Site requirements†

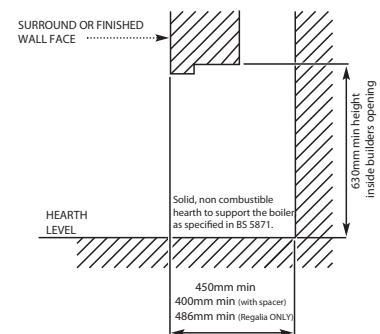
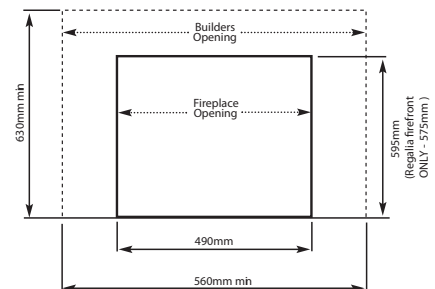

## Site requirements†

- 1 To accommodate the firefront without the need for additional spacers, there must be a gap of at least 94mm from the surround or finished face to the front of the boiler.
- 2 If necessary this gap can be increased by the use of spacer Kits. Each spacer increases the effective depth of the opening by up to 50mm. Alternatively, a range of rebated fire surrounds are available (please see page 13 for details).
- 3 Where surveys highlight that space is restricted versus minimum site requirements, the use of rebated surrounds is recommended.

# Fitting the flue

The Baxi Bermuda BBU HE is only suitable for use with the following flue kits:

Description	Specification	OD Dimensions	Sales Code
10m Concentric Flexible Flue	Complete with terminal	100mm	710143901
12.5m Concentric Flexible Flue	Complete with terminal	100mm	710144001
Flue Pull Cone *		100mm	720111801

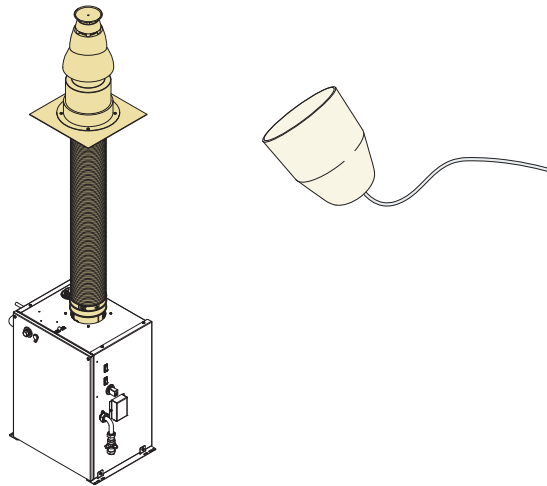

\* The flue pull cone must be used for pulling the concentric flexible flue down the chimney. The flue pull cone can then be retained for future installations.

# The Baxi Bermuda BBU HE Flue Kit

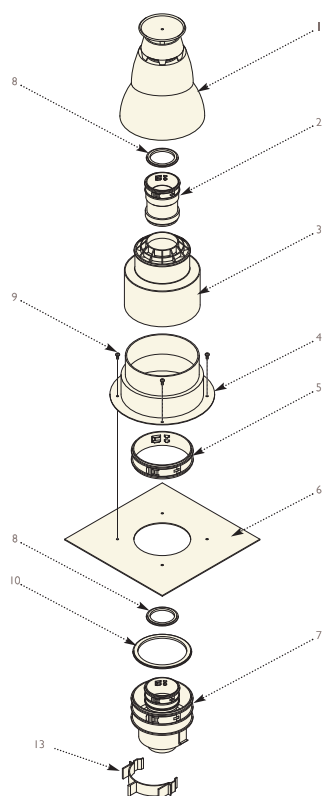

1. Terminal Cap
2. Flue Duct Adaptor
3. Air Cowl
4. Air Duct Collar
5. Air Duct Clamp
6. Closure Plate
7. Boiler Adaptor
8. 60mm Ø Seal
9. Collar Securing Screws x 4
10. 100mm Ø Seal
11. 60mm Ø Flue Duct not shown
12. 100mm Ø Air Duct not shown
13. 'C' Clip

# Flue Installation Guide

- Points 2-6 cover general guidelines for flue installation. For more detailed recommendations, please refer to BS 5440 Part 1 (GB) or I.S. 813 'Domestic Gas Installations' (IE).
- Only one of the two available concentric vertical flue kits approved for use with the Baxi Bermuda BBU HE can be used. Proprietary flue systems, terminals or adaptors etc, should NOT be used.
- The available flue kits are intended for installation within an existing chimney. This should be clean and sound. Previous flue installations (liners, dampeners) should be removed.
- The flue must have a minimum vertical height of 3m and have no bends greater than 45°. No horizontal runs are permitted.
- The terminal must be sited so that free passage of air across it can occur at all times.
- The terminal must be a minimum of 150mm from any other terminals or obstructions (A). When adjacent to windows or openings on pitched or flat roofs it must be at least 600mm away (B). A minimum dimension of 2000mm must be maintained when below windows or openings in pitched roofs (C).

Position	Distance (mm)
A	150
B	600
C	2000



# Valor Fire, Surround, Back Panel and Hearth Technical Specification

FIRES	All measurements given in mm						
Model	Fire only	Boiler & Fire	Fascia Height	Fascia Width	Fascia Depth	Engine Depth	Spacer Depth
Valor Dimension™ Regalia BBU Firefront †	05847A1	720331401	720	600	45	144	50
Valor Dimension™ Innova BBU Firefront ★	0584711	720331301	632	542	38	144	50
Valor Dimension™ Classica Brass BBU Firefront †	0584721	720330701	615	512	51	144	50
Valor Dimension™ Classica Pewter BBU Firefront †	0584701	720330801	615	512	51	144	50
Valor Dimension™ Classica Black BBU Firefront †	05847B1	720330901	615	512	51	144	50
Valor Dimension™ Dream Gold BBU Firefront †	05847C1	720331001	636	518	79	144	50
Valor Dimension™ Dream Chrome BBU Firefront †	05847D1	720331101	636	518	79	144	50
Valor Dimension™ Dream Black BBU Firefront †	05847E1	720331201	636	518	79	144	50
Valor Dimension™ Lyrica BBU Firefront †	0584511	720331601	612	510	74	144	50
Valor Dimension™ Nano Chrome BBU Firefront †	0584521	720331501	616	512	49	144	50

SURROUNDS* AND ACCESSORIES	All measurements given in mm				
Model	Part Number	Height	Width	Depth	Rebate
Calista Oak 6" Rebate Surround	05070P3	1084	1230	220	150
Barcelona Black 6" Rebate Solo-pro Surround	0507052	1032	1170	200	150
Calista Oak Surround	05070B1	1084	1230	190	75/25
Calista Mahogany Surround	05070C1	1084	1230	190	75/25
Clarissa Oak Surround	05070A1	1097	1230	190	75/25
Barcelona Black Surround	05070M2	1032	1170	150	25
Olympia Cream Surround	05070G2	1055	1180	170	25
Teviot White Surround Set	05070W3	1100	1200	380	75
Teviot Maple Surround Set	05070X2	1100	1200	380	75
Medway Oak Surround Set	05070X3	1100	1200	380	75
Medway Mahogany Surround Set	05070Y2	1100	1200	380	75
Solo-Pro 48" Hearth with Back Panel Black	0507011	990	1220	375	N/A
Solo-Pro 48" Hearth with Back Panel Cream	0507001	990	1220	375	N/A
Solo-Pro 48" Hearth with Back Panel White	0507012	990	1220	375	N/A
Classica, Lyrica, Nano & Innova Spacer Kit	5135632	610	503	50	N/A
Regalia Spacer Kit	5135633	715	586	50	N/A
Dream Spacer Kit	5135634	625	504	50	N/A
Right Hand Plumb Kit	720111701	N/A	N/A	N/A	N/A
BBU Wall Fascia ^	05847H1	750	650	157	N/A
10m Concentric Flexible flue	710143901	OD Dimension 100mm (complete with terminal)			
12.5m Concentric Flexible flue	710144001	OD Dimension 100mm (complete with terminal)			
Flue Pull Cone #	720111801	OD Dimension 100mm (complete with terminal)			

\*Please note that a fire surround (new or existing) is required to complete the installation in order to conceal the builders opening.

† This fire is floor standing only.

★ This fire can be wall mounted or floor standing.

^ For use with the Innova fire surround.

# the flue pull cone must be used for pulling the concentric flexible flue down the chimney. The flue pull cone can then be retained for future installations



Valor Dimension™ Lyrica Brass with Medway Surround



# Spacers and Rebated Surrounds

When fitting a BBU HE unit with a Valor Dimension™ fire engine, both the unit and the back of the fire need to be contained within the chimney space. For installations where this space is not sufficient there are two options available:

1. Using a rebated surround: This is the simplest and most discrete solution. Rebated surrounds have a smaller inside return on both the legs and top panel. This allows the back panel to sit further forward, away from the wall, creating a larger space for the BBU HE and Dimension™ fire engine.
2. Using spacer kits: If a rebated surround is not an option, either because the customer wishes to keep their existing surround, or has selected a surround that is not available with a rebate, an additional spacer kit can be used. In these instances, the back panel is fitted as normal, and the Dimension™ fire engine which is visible beyond the back panel is covered with an additional spacer kit. The BBU HE spacer kits are 50mm deep, and can be joined together to achieve the required depth.

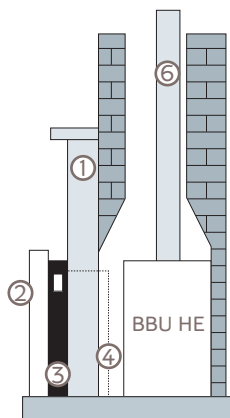

Standard BBU HE installation

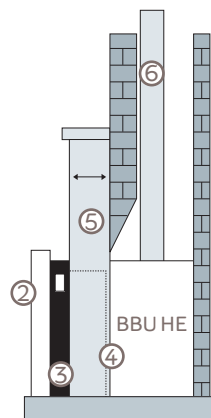

BBU HE with rebated surround

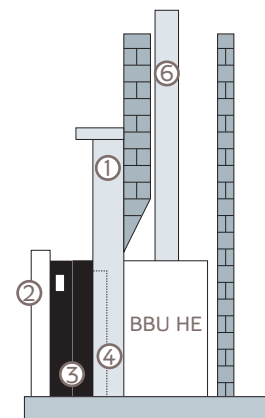

BBU HE with additional spacers

- |                               |                                 |
|-------------------------------|---------------------------------|
| 1. Standard surround          | 3. Spacer frame                 |
| 2. Valor Dimension™ firefront | 4. Valor Dimension™ fire engine |

- |                     |
|---------------------|
| 5. Rebated surround |
| 6. Flue             |

## Controls

A remote control is supplied with the Regalia, Innova, Classica and Dream fires. The Lyrica and Nano models have built in manual controls. Both the remote control and the manual control allow settings for 'On/Off', 'Effect Only', 'Low 1kW heating' and 'High 2kW heating'.



# Alternative Solutions

To ensure all heating and hot water demands are satisfied, and the new BBU installation runs smoothly, it is important that you assess the minimum site requirements. To help you with the assessment, please refer to the site survey on page 18. It will help you determine whether a replacement BBU is the most appropriate application and which components you need. If the BBU HE does not meet your requirements, Baxi Group has the solution for you.

## The Baxi Group

Baxi Group is one of Europe's biggest manufacturers and distributors of domestic and commercial water and space heating systems. The group includes some of the best known and most respected brands in the heating industry: Baxi, Elson, Heatrae Sadia, Valor, Andrews Water Heaters, Santon and Potterton Commercial.

## Baxi Boilers

If the property doesn't meet the minimum site requirements for the installation of a Baxi Bermuda BBU HE, you can still take advantage of our range of high efficiency boilers to update your system. They are all built to the same high standard of quality, reliability and efficiency.

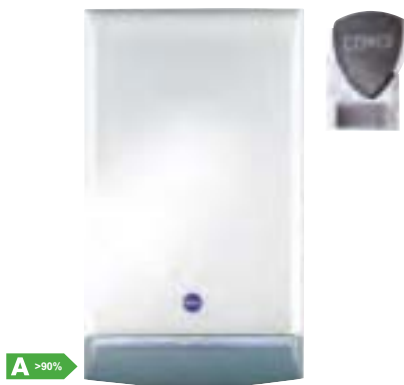

### Baxi Duo-tec Combi HE A

Baxi's award winning range of high efficiency combi boilers is available in 24, 28, 33 and 40 kW outputs. LPG Models are also available.



### Baxi Megaflo System HE A

Baxi's system boiler range is available in 15, 18, 24, 28 and 32 kW outputs. LPG Models are also available.



### Baxi Solo HE A

Baxi's heat only boiler range is available in 12, 15, 28, 24 and 30 kW outputs.

## Heatrae Sadia Cylinders

For your hot water storage needs, put your trust in a stainless steel cylinder from Heatrae Sadia, the UK's leading manufacturer of hot water systems and home of the Megaflo unvented systems. Heatrae Sadia offers the best in innovation, quality and reliability – backed up by a lifetime cylinder leak warranty.



### Megaflo HE

The Megaflo HE is an unvented cylinder, delivers mains pressure hot water and is available in 70-300 litre capacities in both direct and indirect versions.



### Megalife Vented

The Megalife HE is a vented cylinder available in 100-210 litre capacities in both direct and indirect versions.



### Megaflo Systemfit

The Megaflo Systemfit is a pre-plumbed version of the Megaflo HE and is designed to reduce on-site installation time. It is available in 125-300 litre capacities.

## Valor Fires

To complete your replacement installation, create that all important focal point in the living room with a gas or electric fire from Valor. Valor's wide range of gas and electric fires and stoves come in a variety of style fronts to offer something for every taste, from contemporary designs to traditional cast iron fires.



### Valor Gas Fires

Valor's wide range of gas fires offers high efficiency and exceptional heat output. Valor has a variety of design and style options to suit all living spaces and chimney types.



### Valor Stoves

The Valor solid fuel stove range is the authentic heating experience which provides both performance and reliability.



### Valor Suites and Surrounds

Valor offers a range of fire suites in a variety of finishes suitable for any living space. Valor has a wide selection of surrounds suitable for both gas and electric fires.



### Valor Dream Hydroflame

This unique product provides the real fire look but works like a radiator – it installs directly to the central heating circuit with an output of up to 2kW. Valor Hydroflame can replace an existing gas fire to provide a safe and controllable heat source when replacing an existing back boiler.

# After sales support

**heateam**

The service division of Baxi Group

heateam is Baxi Group's own team of engineers who offer customers complete peace of mind by providing free support during the warranty period. heateam also offers a range of services for out-of-warranty appliances. No-one is more qualified to repair or service a Baxi appliance.

- heateam employs over 280 engineers providing nationwide coverage
- heateam's service centre is open 7 days per week, 363 days per year
- heateam offers priority technical support to installers registered with the Gas Safe Register via our trade technical advice line
- heateam supports all Baxi Group appliances, with unrivalled expertise in our own heating products
- heateam vans are fully stocked with Baxi Group spare parts, we can repair appliances on the first visit 95% of the time
- heateam only uses official Baxi Group spare parts – quality and safety are always our prime concern

heateam achieved seventh place in the 2010 Top 50 Call Centres for Customer Service following the UK's biggest ever call centre benchmarking exercise.

The study was conducted by independent market research company GfK, who made 18,500 mystery shopper enquiries to the call centres to identify the best performers. Each call centre was rated, using over 50 criteria, on timeliness, ease of use, reliability, staff knowledge and personal service and awarded a customer service rating.

heateam has been given this award for the last two years showing on-going commitment to providing top class to all its customers.



[www.heateam.co.uk](http://www.heateam.co.uk)





# Baxi Bermuda BBU HE Site Survey Form

To help with a simple installation complete the site survey overleaf.  
(To be completed by a Gas Safe Registered installer.)



## Baxi Bermuda BBU HE Site Survey Form

NB: If the answer is NO to any of the points below then read the adjacent comments for further guidance.

	Yes	No	Comments
Is the gas supply natural gas?	<input type="checkbox"/>	<input type="checkbox"/>	No LPG model currently available.
Is the boiler fitted to a fully pumped system?	<input type="checkbox"/>	<input type="checkbox"/>	If the heating system is a gravity hot water pumped heating system it must be converted to a fully pumped system Y or S Plan.
Is the flow and return connection on the left hand side of the boiler? (looking at the boiler)	<input type="checkbox"/>	<input type="checkbox"/>	If the existing pipe work is connected from the right hand side then the optional extra pipe work kit may be required to facilitate installation.
Does the system incorporate a bypass?	<input type="checkbox"/>	<input type="checkbox"/>	A pressure operated bypass will be required if the minimum flow rate is lower than 8.3 litre/minute.
Is the boiler installed to a Class 1 Flue?	<input type="checkbox"/>	<input type="checkbox"/>	225mm x 225mm (9" x 9") brick or 175mm (7") salt glazed lined flue is required.
Check builders opening (see comments).	<input type="checkbox"/>	<input type="checkbox"/>	630mm height, 560mm width, 450mm depth is the minimum size of the builders opening. If only the minimum depth is available a range of spacer kits or rebated surrounds are available for the firefront (see page 13 of the Baxi Bermuda BBU HE brochure).
Is an existing fire surround installed? (see comments).	<input type="checkbox"/>	<input type="checkbox"/>	The minimum fireplace opening size is 595mm (Regalia 575mm) height x 490mm width. If installing with minimum fireplace dimensions provision will need to be made for access to the gas service cock and inlet test point. The surround will need to be removed to allow access for installation of the BBU.
Does the existing fire have an electric light effect?	<input type="checkbox"/>	<input type="checkbox"/>	The boiler will require a 3 amp permanent live as well as a switched live feed from the same source to operate satisfactorily.
Is there a 13 amp socket in close proximity to the existing fire and boiler location? (see comments)	<input type="checkbox"/>	<input type="checkbox"/>	The fire will require a separate 13 amp supply.
Will there be a clearance of 150mm from the BBU flue terminal to an adjacent terminal?	<input type="checkbox"/>	<input type="checkbox"/>	150mm clearance is required from the BBU flue terminal to an adjacent terminal.
Measure and check the flue length and its path. (see comments).	<input type="checkbox"/>	<input type="checkbox"/>	There are 2 concentric flue system kits available, 10 metre and 12.5 metre both with a minimum flue length of 3 metres. These lengths may be cut shorter but cannot be extended beyond their specified length.
Is there a waste drain point close to the boiler location? (see comments).	<input type="checkbox"/>	<input type="checkbox"/>	The boiler incorporates a sump pump for the removal of condensate. The pump can lift condensate vertically 2.5 metres (as measured from the case outlet of the boiler.) Any horizontal run should be kept as short as practicable with a minimum of 3 degrees on all gravity falls. For guidance on maximum horizontal runs and number of elbows please refer to Baxi's Installation Instructions at <a href="http://www.baxi.co.uk">www.baxi.co.uk</a> .

# Training

As part of our Baxi boiler training days, Baxi offers a Baxi Bermuda BBU HE training course for Gas Safe Registered installers. The hands-on course will take you through all the components of the BBU, flue system and fire front. It covers the system and site requirements, gas and electrical supply, as well as installation of boiler, flue and fire. The course also takes you through key BBU diagnostics.

## On completion of the course delegates will be able to:

- Understand the Baxi Bermuda BBU HE and how it works
- Be able to install the back boiler, flue and fire front
- Understand the sequence of operation of a back boiler

The skills you gain will enable fast, trouble-free installation, increase confidence in the servicing, maintenance and trouble-shooting of appliances and lead to complete customer satisfaction in your services and our products.

## Who should attend?

Heating engineers, installers, maintenance engineers and specifiers who require a greater knowledge and understanding of the Baxi Bermuda BBU HE and to capitalise on the opportunity this product presents.

## Suggested prior knowledge or understanding

Knowledge of heating and hot water systems. ACS or equivalent qualification.

## Baxi Group Training

Our training facilities are centres of excellence for the heating industry. They offer hands-on experience and expert in-depth tuition. Our courses cover everything from high efficiency boilers, unvented water systems, recognising and repairing appliance faults, through to electrics, using multimeters and renewable energy products.

We endeavour to provide training courses that are convenient, flexible and effective. We want you to leave with in-depth knowledge and understanding of our products, that's why we offer to tailor our courses to suit your specific needs, ensuring your time spent with us is worthwhile.

For a full list of courses and locations visit

[www.baxigrouptraining.com](http://www.baxigrouptraining.com) or call 0845 600 7402

# Contact us

For all enquiries, please call

**0844 871 1525**

email: [info@baxi.co.uk](mailto:info@baxi.co.uk)

visit: [www.baxi.co.uk](http://www.baxi.co.uk)

Open Monday - Friday, 8am - 6pm.

Weekends and Bank Holidays, 8.30am - 2pm.

We are closed Christmas Day & New Years Day.

To book for a training course  
please call

**0845 600 7402**

Open Monday - Thursday, 8.30am - 5pm.

Friday, 8.30am - 4.30pm.

Please note calls may be monitored or recorded

# BAXI

Baxi, Brooks House,

Coventry Road, Warwick CV34 4LL

[www.baxi.co.uk](http://www.baxi.co.uk)

Valor, Wood Lane, Erdington,

Birmingham, B24 9QP

[www.valor.co.uk](http://www.valor.co.uk)

PART OF BDR THERMEA

BBUHE/Oct10/V4/372075-05

# Valor DIMENSION



This Brochure is printed on paper sourced from well managed forests and other controlled sources. This Brochure is printed using vegetable based inks. Please recycle this Brochure when you have finished with it.

Baxi policy is one of continual improvement and development. The right to change specification and appearance without prior notice is reserved. The reproduction of colours is as accurate as photographic and printing processes allow.

The consumer's statutory rights are not affected. e&oe