

APPENDIX

APPENDIX 1. Warranty Conditions

The following is a summary of the Warranty conditions, but a full version is available from Atmos.

The Warranty includes:

1. Within the specified time period, the Atmos Warranty covers all products supplied against any material construction or operation faults that are found to be of original manufacturing origin, so long as all the conditions of this warranty have been complied with.
2. The warranty period is for 2 years from the date of invoice, or 12 months from the date of installation, whichever has the later expiry date. It covers the replacement of faulty parts and labour, excluding the ignition electrode, ionisation probe and automatic air vent. .
Atmos gives a 1 year warranty on replacement parts.
3. The warranty period for the heat exchanger and the water heater tank of the appliance is 5 years, subject to manufacturer's conditions
4. All products must be used in an appropriate application and manner. This includes but is not limited to: correct boiler sizing, system design, system cleansing and use of corrosion inhibitors. Where appropriate and always in areas of Hard Water(in excess of 200ppm), an approved water conditioner device must be fitted (in accordance with Building Regulations).
5. The Benchmark Boiler Commissioning Checklist/Service Record must be completed and kept up to date, and a copy supplied to Atmos if required, as proof of correct commissioning and service. In addition the Warranty card must be completed, and the signed Atmos copy received by Atmos within 8 days of installation. By signing the Warranty card, the buyer agrees that the goods have been delivered in a satisfactory condition.
6. The warranty and guarantee provision shall no longer be valid when it is established that the defects, damage or excessive wear are due to improper use or injudicious treatment or to unskilful repair, adjustment, installation or maintenance by non-approved installers.
7. This warranty shall not apply if the fault is caused by the deposition of scale, failure or abnormality of gas or water supply, or impact of any external influence that adversely affects the normal operation of the product. This shall include but not be restricted to dehydration, abnormal or high voltage, and hard water.
8. Surface damage and transport damage are outside the scope of this warranty.
9. The guarantee lapses if the boiler has not had a yearly service by an approved service agent. The instructions of installation and use that we supply for the respective appliances must be fully observed.

Note: An extended Warranty period is available as an option from Atmos.

APPENDIX 2. Spare Parts List

Atmos Multi Mk 2 Parts List

Drg Ref	Description	Atmos Multi 24/80				Part Ref.
1	Wall bracket	*	*	*	*	07.98.37.043
2	Bracket fixing kit	*	*	*	*	07.95.82.006
3	Rear casing	*	*	*	*	07.90.22.080
3.1	AAV Grommet 15 mm red/brown	*	*	*	*	07.98.68.026
3.2	Casing latches kit	*	*	*	*	07.90.82.009
4	Locking pin	*	*	*	*	07.98.43.018
5	Air intake pipe	*	*	*	*	07.98.74.298
6	Automatic closing device 3/8"	*	*	*	*	75.06.65.001
7	Automatic air vent 3/8"	*	*	*	*	79.40.26.001
8	Flue gas pipe	*	*	*	*	07.98.74.295
8	Flue gas temp measuring point	*	*	*	*	07.95.15.002
9	Flue pipe	*	*	*	*	07.98.74.286
10	Gas pipe (until end 2006)	*	*	*	*	07.98.74.282
10	Gas pipe (Jan 2007 onwards)	*	*	*	*	07.98.74.411
11	Gas valve & fittings set (until end 2006)	*	*	*	*	07.95.00.002
11	Gas valve & fittings set (see note 2) (Jan 2007 onwards)	*	*	*	*	07.95.78.005
11.1	Gas valve (Honeywell VR4605 to end 06)	*	*	*	*	07.98.78.003
11.1	Gas valve (Honeywell VK4115 Jan 07 on) (see note 2)	*	*	*	*	07.98.78.023
11.2	O-Ring 26,57x3,53 (until end 2006)	*	*	*	*	07.98.83.190
11.2	O-Ring 26,57x3,53 (Jan 2007 onwards)	*	*	*	*	07.98.83.166
11.3	Bolt M5x8 (until end 2006)	*	*	*	*	82.27.02.908
11.3	Bolt M5x8 (Jan 2007 onwards)	*	*	*	*	82.08.93.046
11.4	Nipple 1/2"	*	*	*	*	07.98.74.312
12	Sealing washer	*	*	*	*	07.98.83.189
13	Connecting tube - 24 Model	*	*			07.95.74.024
13	Connecting tube - 32 Model			*		07.95.74.025
13	Connecting tube - 38 Model				*	07.95.74.038
14	Fixing nut M6	*	*	*	*	07.98.82.120
15	Flow pipe set	*	*	*	*	07.95.00.003
15.1	Flow pipe	*	*	*	*	07.98.74.283
15.2	(deleted)					75.66.99.027
15.3	Tightening ring 22 mm	*	*	*	*	07.98.74.155
15.4	Tightening nut M27x1,5	*	*	*	*	07.98.82.119
15.5	CH Temperature sensor	*	*	*	*	07.98.63.042
15.6	Plug 1/2"+ O-Ring	*	*	*	*	74.53.80.016
16	Tank set	*				07.95.05.008
16	Tank set – 24 Plus, 32 Plus Models		*	*		07.95.05.009
16	Tank set – 38 Plus Model				*	07.95.05.015
16.1	Tank frame	*	*	*	*	07.98.30.006
16.2	Earthing washer M8	*	*	*	*	07.98.82.114
16.3	Hex bolt M8x12	*	*	*	*	07.98.82.112
16.4	Sealing washer M8	*	*	*	*	82.74.06.903
16.5	Pump/heat exchanger pipe	*	*	*	*	07.98.74.285

Atmos Multi Mk 2 Parts List

Drg Ref	Description	Atmos Multi 24/80				Part Ref.
		*	*	*	*	
16.6	Union nut 1"	*	*	*	*	07.98.82.113
16.7	O-Ring 22x3.0	*	*	*	*	07.98.83.227
16.8	Bracket bolt	*	*	*	*	07.98.43.017
16.9	Silicone sealing ring	*	*	*	*	07.98.83.231
16.10	Adjusting screw M6x25	*	*	*	*	07.98.82.117
16.11	Support collar 22 mm	*	*	*	*	07.98.74.206
16.12	Earthing tab 6,3 mm 45°	*	*	*	*	68.31.12.828
16.13	Screw M4x8 self tap	*	*	*	*	82.08.93.046
17	Thermostat	*	*	*	*	78.76.54.981
18	Rear insulation	*	*	*	*	07.98.83.229
19.1	Burner casting	*	*	*	*	07.98.07.008
19.2	Fan casing	*	*	*	*	07.98.83.185
19.3	Fan	*	*	*	*	07.98.36.003
19.4	Nut M4	*	*	*	*	07.98.82.080
19.5	Viewing glass set	*	*	*	*	07.95.26.003
19.6	Burner set for 24 & 32 Models	*	*	*	*	07.95.25.002
19.6	Burner set for 38 Model	*	*	*	*	07.95.25.007
19.7	Ionisation probe set	*	*	*	*	07.95.78.004
19.8	Ignition electrode set	*	*	*	*	07.95.70.006
19.8	Sealing ring for ionisation/ignition electrode	*	*	*	*	07.98.83.226
19.9	O-Ring 80x2	*	*	*	*	07.98.83.184
19.10	Mixing chamber 25 mm - 24 Model	*	*	*	*	07.98.16.002
19.10	Mixing chamber 28 mm - 32 Model	*	*	*	*	07.98.16.001
19.10	Mixing chamber 30 mm - 38 Model	*	*	*	*	07.98.16.005
19.11	Screw M6x8	*	*	*	*	07.98.82.082
19.12	Grommet 15 mm	*	*	*	*	07.98.68.041
19.13	Nipple cover Ø 6 mm	*	*	*	*	07.98.15.092
20	Ceramic core	*	*	*	*	07.98.27.001
20	Extension piece for 32 Plus, 38 Plus	*	*	*	*	07.98.27.003
21	Mid baffle for 24, 24 Plus	*	*	*	*	07.98.41.027
21	Mid baffle for 32 Plus, 38 Plus	*	*	*	*	07.98.41.031
22	Lower baffle	*	*	*	*	07.98.41.030
23	Condensate collector	*	*	*	*	07.98.07.007
24	Siphon 32x140 mm	*	*	*	*	07.90.74.200
25	Sealing washer 60 mm	*	*	*	*	07.98.83.233
26	Lifting bar set	*	*	*	*	07.95.74.023
27	CH pump (inc. cable loom K5)	*	*	*	*	07.95.36.002
27	CH pump (inc. cable K5) for 38 Plus	*	*	*	*	07.95.36.003
28	3 Port valve (inc. cable loom K7)	*	*	*	*	75.83.01.004
28	3 Port valve actuator	*	*	*	*	75.83.01.006
29	Return pipe for CH pump	*	*	*	*	07.98.74.284
30	Pressure sensor	*	*	*	*	07.98.78.004
31	Pump seal 30 mm	*	*	*	*	07.98.83.230
32	Union nut 1"	*	*	*	*	07.98.82.113
33	Short pipe for pump	*	*	*	*	07.98.74.288
34	T-piece 22x22x22 mm	*	*	*	*	07.98.74.304
35	Pipe with bend - pump	*	*	*	*	07.98.74.296
35	Pipe with bend – helix coil	*	*	*	*	07.98.74.287
36	Elbow connection 22x22 mm	*	*	*	*	74.64.30.958

Atmos Multi Mk 2 Parts List

Drg Ref	Description	Atmos Multi 24/80				Part Ref.
		*	*	*	*	
37	Front insulation	*	*	*	*	07.98.83.228
38	Flow pipe	*	*	*	*	07.98.74.308
39	Bracket	*	*	*	*	07.98.37.042
40	Ignition transformer (until end 2006)	*	*	*	*	07.98.61.001
40	Ignition transformer (see note 2) (Jan 2007 onwards)	*	*	*	*	07.98.61.002
41	Screw M4x8 self tap	*	*	*	*	82.08.93.046
42	Hex bolt M8x12	*	*	*	*	07.98.82.112
43	Controller mounting plate	*	*	*	*	07.95.30.001
44	Controller with front plate	*	*	*	*	07.90.80.028
44	Controller	*	*	*	*	07.95.64.001
45	Controller front plate	*	*	*	*	07.90.80.023
46	Front case set	*	*	*	*	07.95.22.004
47	Data Plate 24 Model	*				07.98.35.294
47	Data Plate 24 Plus Model		*			07.98.35.295
47	Data Plate 32 Plus Model			*		07.98.35.297
47	Data Plate 38 Plus Model				*	07.98.35.321
48	Screw M3x 25	*	*	*	*	07.98.82.115
100	Cable loom K1 (room thermostat)	*	*	*	*	07.98.66.178
101	Cable loom K2 (pressure sensor)	*	*	*	*	07.98.66.206
102	Cable loom K4 (CH flow & tank temp sensors)	*	*	*	*	07.98.66.212
103	Appliance selection 24 Model	*				07.98.63.043
103	Appliance selection 24 Plus Model		*			07.98.63.044
103	Appliance selection 32 Plus Model			*		07.98.63.046
103	Appliance selection 38 Plus Model				*	07.98.63.053
104	Tank temperature sensor	*	*	*	*	07.98.63.047
105	Cable loom K5 (CH pump)	*	*	*	*	07.98.66.208
106	Cable loom K6 (Gas valve, max. thermostat, Ionisation/ Ignition electrode) (until end 2006)	*	*	*	*	07.98.66.202
106	Cable loom K6 (Jan 2007 onwards) (see note 2)	*	*	*	*	07.98.66.228
107	Cable loom K7(included with 3 port valve)	*	*	*	*	-
108	Cable loom K8 (fan)	*	*	*	*	07.98.66.201
109	Cable K11 (main boiler earth)	*	*	*	*	07.98.66.207
110	Cable loom K12 (ignition earth) (Jan 07 onwards: included with item 40)	*	*	*	*	07.98.66.204
111	Cable loom K13 (ignition)	*	*	*	*	07.98.66.210
112	Mains lead	*	*	*	*	07.98.66.120
Note 1	Temp. & pressure relief valve	*	*	*	*	07.92.64.032
Note 1	Temp. & press. valve discharge pipe	*	*	*	*	07.99.74.537

Note 1 – This part is not shown in the diagrams. Please refer to the Boiler Schematic (Section 4).

Note 2 – The gas valve and fittings including the ignition transformer have been changed to new components, and the ignition transformer is now fitted onto the valve.

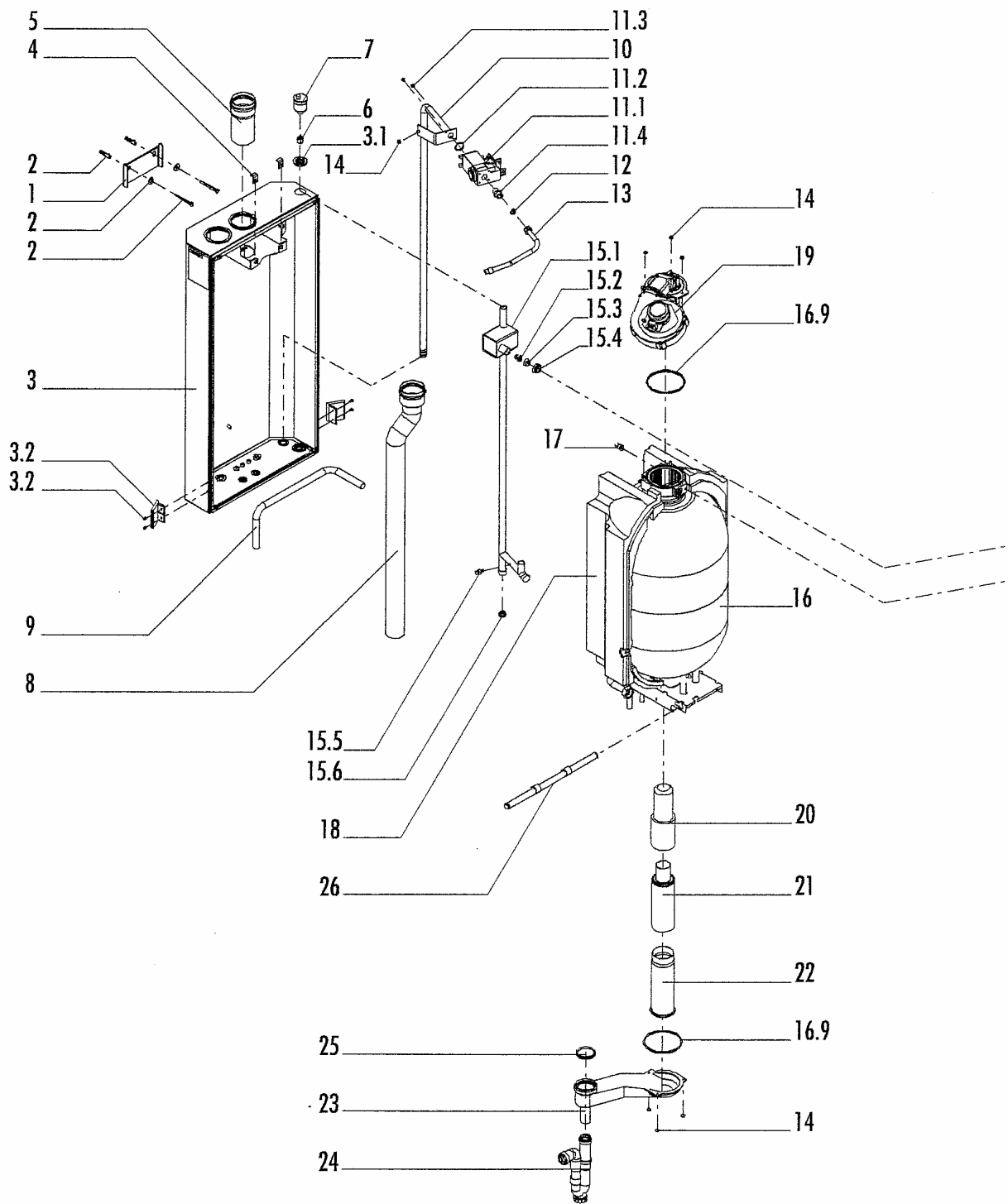

CombiFort 24/80 - 24/80+ - 32/80 - 32/80+

07.94.12.040.0

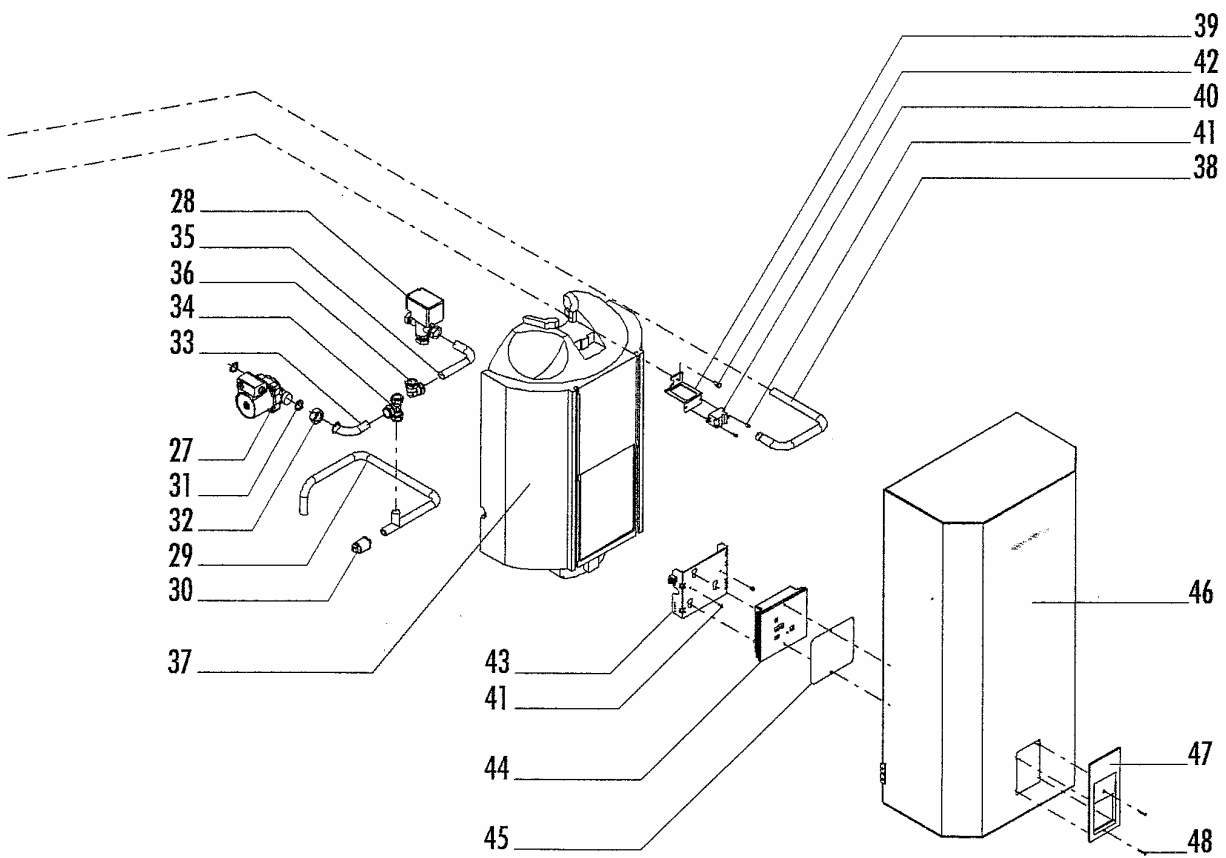
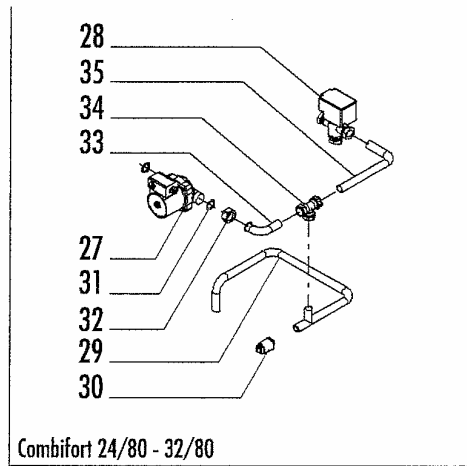

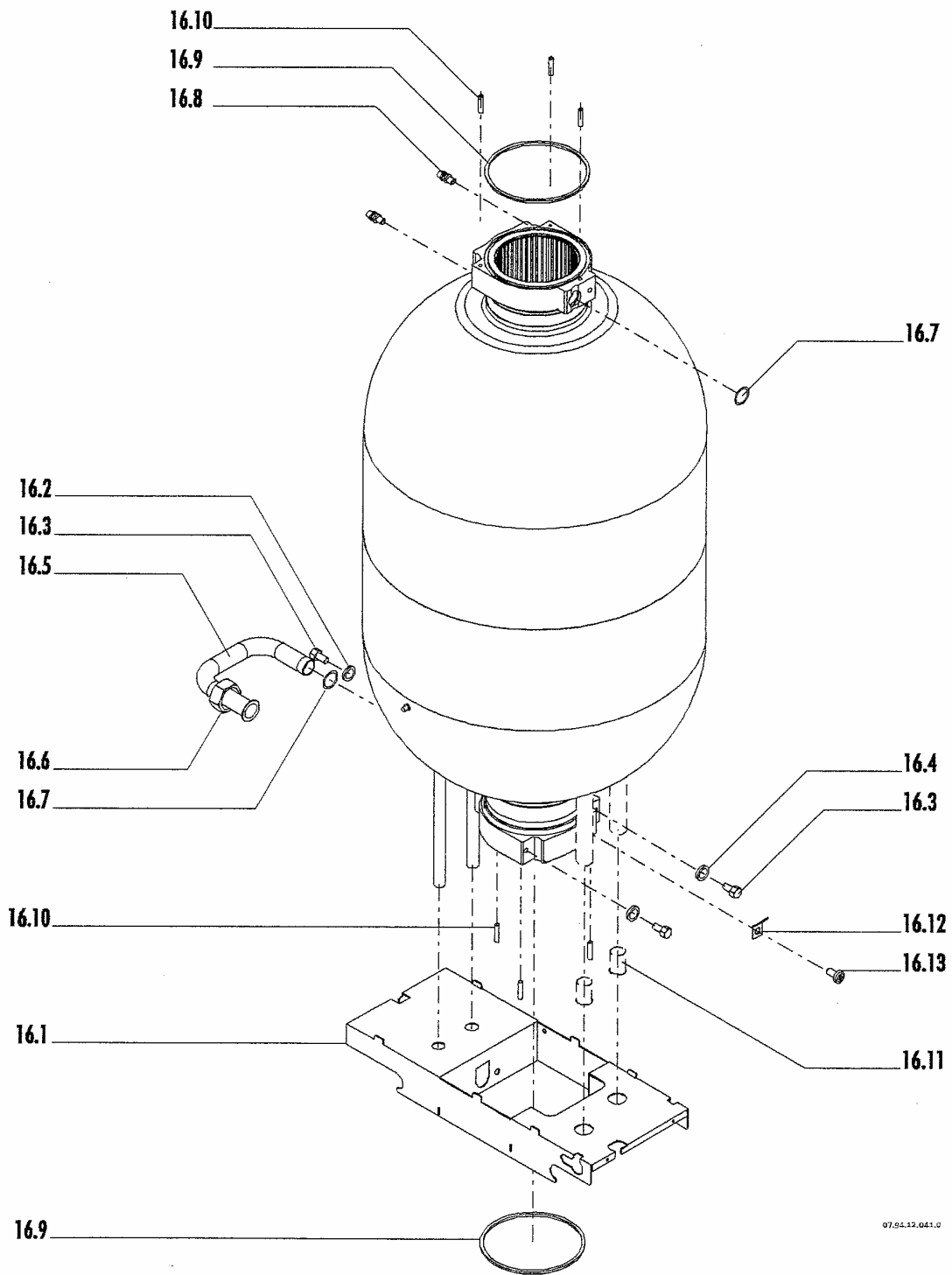

07.94.12.041.0

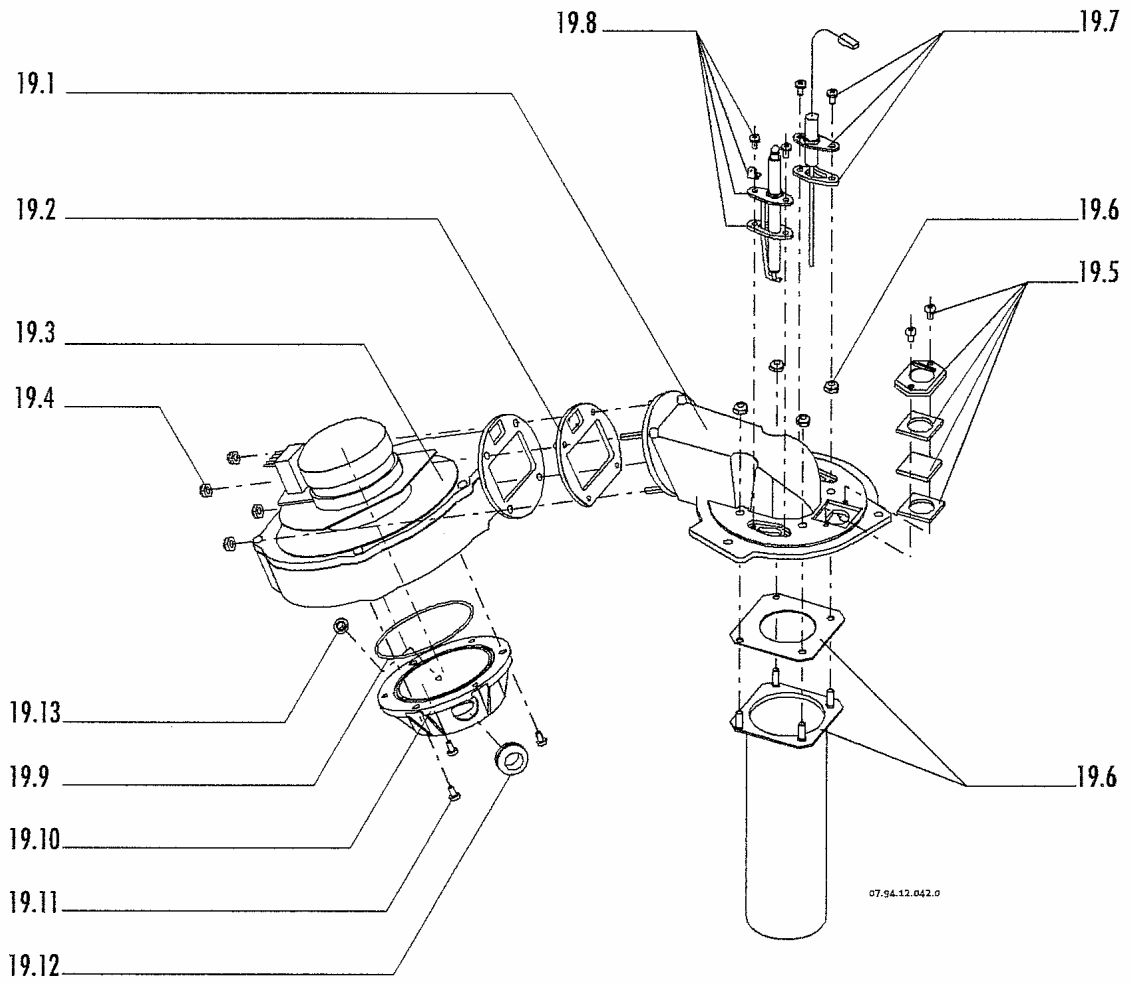

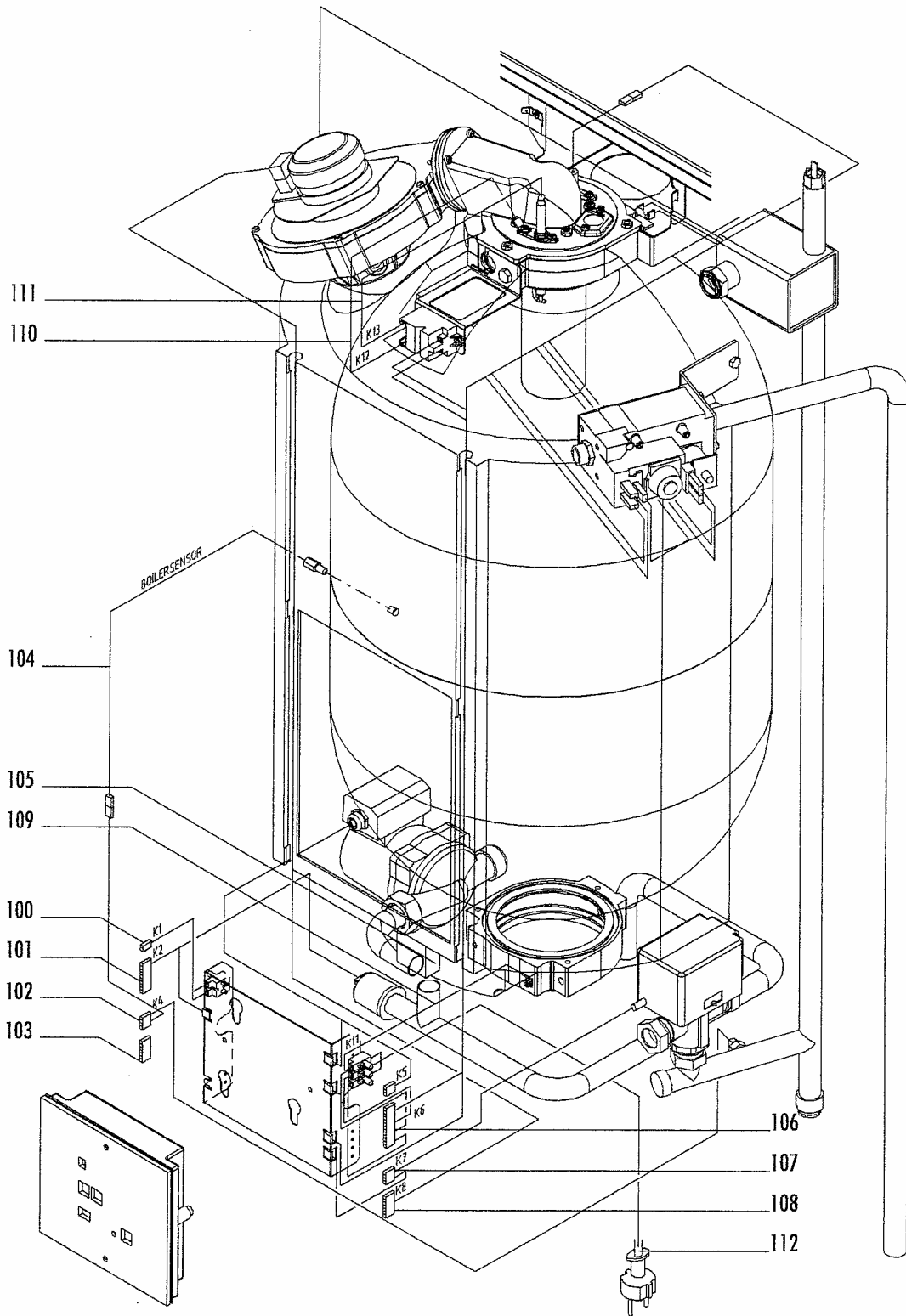

APPENDIX 3. Fault Finding

1. GENERAL

The *Atmos Multi* has 3 types of error messages:-

1. Warning messages

In this case, instead of the status message, a letter appears on the diagnostic display for one second, once every 5 seconds.

2. Blocking messages

A permanently illuminated letter appears on the diagnostic display.

3. Malfunction messages

A flashing letter or number appears on the diagnostic display.

In the event of a warning message, the function to which the message applies will be switched off while the appliance continues to operate.

In the event of a malfunction message, the entire appliance will be shut down requiring manually resetting before the boiler will continue operation.

OPERATING CODES ON ATMOS MULTI

See also Table 1 in Section 5 of the Manual. The following appear on the status display:-

- | | |
|----------|---|
| 1 | Hot water heating operating |
| 2 | Central heating operating |
| 3 | Hot water and central heating – priority to hot water |
| 4 | Hot water and central heating - supply to both |

The dot in the bottom right hand corner of the diagnostic display indicates the following burner function:-

No dot	No burner
Slow flashing dot	Minimum fire
Increasingly fast flashing dot	Higher & higher firing
Constant dot	Burner on maximum output

The dot in the bottom right hand corner of the central heating display: -

Dot	Motorised valve energised to send water to the central heating circuit
------------	--

2. SUMMARY OF MESSAGES

This section provides a brief description of the warning, blocking and malfunction messages which appear on the appliances diagnostic display. The causes of these messages are addressed in more detail in section 3.

2.1 Warning messages

A warning message is identified by a letter that appears on the diagnostic display once every 5 seconds, for a period of 1 second, instead of the status message.

Diagnostic display code		
Status message (Number)	Warning every 5 seconds	Message
8	b	Incorrect hot water tank temperature reading, value <-10°C or> 118°C
	c	Incorrect central heating water pressure, value between 0 and 0.5 bar or 3 and 4 bar (capacity is limited to low setting)
	d	Incorrect central heating return sensor reading, value <-10°C or> 118°C
	h	Incorrect outside sensor reading, value <-15°C or>118°C

2.2 Blocking messages

A blocking is an error that occurs without causing a malfunction. The appliance waits until the blocking has been resolved and then continues to operate normally. A blocking is indicated by a permanently lit letter on the diagnostic display.

Code		
Diagnostic display	Central heating water display	Message
c	HH	Central heating water temperature sensor error value >118°C
	LL	Central heating water temperature sensor error, value <-10°C
C*		Central heating pressure lower than 1 bar (occurs when the plug is inserted into the power socket)
F		Mains frequency error
H		Internal error
L		Electrical mains plug error-correct supply polarity
n		Mains or reference voltage too low
t	HH	Appliance type recognition error, value >118°C
	LL	Appliance type recognition error, value <-10°C
	10	Appliance type recognition error, control unit is set to 24/80
	11	Appliance type recognition error, control unit is set to 24/80 ^{plus}
	20	Appliance type recognition error, control unit is set to 32/80
	21	Appliance type recognition error, control unit is set to 32/80 ^{plus}
	31	Appliance type recognition error, control unit is set to 38/80 ^{plus}

* this code will not be stored in the memory

2.3 Malfunction messages

A malfunction is an error which is so serious that the appliance is locked. A malfunction message is identified by a locked control unit accompanied by a flashing number or letter on the diagnostic display. The appliance can only be unlocked by pressing the reset button.

Code		Message
Diagnostic display	Central heating water display	
2		Fan defective (5Hz deviation per minute)
3		Incorrect ionisation (flame) signal
3.		No ionisation (flame) signal during start-up procedure
4		Ionisation signal absent during heat supply (diagnostic code 1-4)
4.		Ionisation signal remains present too long after heat supply
6.		Gas valve control defective
7		Insufficient flow of central heating water during hot water heating
7.		Insufficient flow of central heating water during radiator heating
8		Maximum thermostat cuts out and central heating water pressure was lower than 0.5 bar
9		Maximum thermostat cuts out and central heating water sensor was higher than 80°C
9.		Safety internal malfunction in control unit
Letter		Internal malfunction in control unit
(Dark display)		Appliance receiving no voltage

3. CAUSES OF MESSAGES

3.1 Warning messages

A warning message is identified by a letter that appears on the diagnostic display every five seconds for a period of one second instead of the status message. The appliance continues to operate, but the function to which the message applies will be switched off or ignored. Once the cause of the warning message has been solved, the appliance will start up again automatically so resetting is not necessary. The possible causes are described below in order of probability. Also look for the malfunction in this order.

Diagnostic display code			Central heating water display code	
Status message (Number)	Warning every 5 seconds	Diagnosis	Message	Cause
	b	Hot water tank temperature <-10°C or >118°C. In sub-program sensor values the message HH (>118°C) or LL (<-10°C) appears on the central heating water display.	HH	<ul style="list-style-type: none"> Central heating temperature >118°C Connector K4 loose or improperly connected Temperature sensor wiring interrupted Sensor defective Control unit
			LL	<ul style="list-style-type: none"> Control heating temperature <-10°C Short circuit in temperature sensor wiring Sensor defective Control unit

	c	Central heating water pressure too low or too high. Limiting the output to the appliances lowest capacity. The current central heating water pressure is shown on the central heating display. If the central heating water temperature is set on the central heating display, the current central heating water pressure can be read through 'sub-program sensor values'	0 – 0.5 BAR	<ul style="list-style-type: none"> Central heating system lacking water pressure No venting of the central heating system through the automatic de-aerator Leak in the appliance or central heating system Central heating pressure sensor defective
			3 – 4 BAR	<ul style="list-style-type: none"> Central heating system over pressurised Expansion tank defective Central heating pressure sensor defective
	d	Central heating return temperature <-10°C or >118°C. In sub-program sensor values, HH (>118°C) or LL (<-10°C) will appear on the central heating water display.	HH	<ul style="list-style-type: none"> See cause of HH in status message
			LL	<ul style="list-style-type: none"> See cause of LL in status message
	h	Outside temperature<-10°C or >118°C. In sub-program sensor values, HH (>118°C) or LL (<-10°C) will appear on the central heating water display.	HH	<ul style="list-style-type: none"> See cause of HH in status message
			LL	<ul style="list-style-type: none"> See cause of LL in status message

3.2 Blocking messages

A blocking message is identified by a permanently illuminated letter on the diagnostic display. Once the blocking has been solved, the appliance will start up again automatically. So resetting is not necessary.

The possible causes are described below in order of probability. Also look for the malfunction in this order.

Code		Diagnosis	Cause
Diagnostic display	Central heating water display		
c	HH	Central heating water temperature > 118°C	<ul style="list-style-type: none"> See cause of HH in 'status message/b' [3.1]
	LL	Central heating water temperature < -10°C	<ul style="list-style-type: none"> See cause of LL in 'status message/b' [3.1]
C*		Appliance blocked because central heating system pressure is too low	<ul style="list-style-type: none"> Central heating pressure lower than 1 bar
F		Mains frequency error	<ul style="list-style-type: none"> If this blocking occurs frequently or for a long period, replace control unit
H		Internal error	<ul style="list-style-type: none"> If this blocking occurs frequently or for a long period, replace control unit
L		Electrical mains supply	<ul style="list-style-type: none"> Mains supply has wrong polarity Not earthed Ionisation electrode earth wire loose Control unit
n		Mains or reference voltage too low	<ul style="list-style-type: none"> Mains voltage < 200 volts Mains voltage insufficient Control unit
t	HH	Appliance type recognition error, value > 118°C	<ul style="list-style-type: none"> Control unit selected incorrectly Selection resistance defective Control unit defective
	LL	Appliance type recognition error, value < -10°C	
	10	Appliance type recognition error, the control unit is set to 24/80	
	11	Appliance type recognition error, the control unit is set to 24/80 ^{plus}	
	20	Appliance type recognition error, the control unit is set to 32/80	
	21	Appliance type recognition error, the control unit is set to 32/80 ^{plus}	
31	Appliance type recognition error, the control unit is set to 38/80 ^{plus}		

* this code will not be stored in the memory

3.3 Malfunction messages

A malfunction message is indicated by a flashing number or letter on the diagnostic display combined with a locked control unit. Once the malfunction is solved, the control unit must be unlocked by pressing the reset button once. Should the control unit fail to unlock, try again after approx. 20 seconds.

The possible causes are described below in order of probability. Also look for the malfunction in this order.

Code	Diagnosis	Cause
Diagnostic display		
2	Fan defective (5 hz deviation per minute)	<ul style="list-style-type: none"> • Fan not turning • Fan's electrical connection loose or improperly connected • Control unit
3	Incorrect ionisation (flame) signal	<ul style="list-style-type: none"> • Valve in gas valve remains open or leaks • Control unit
3.	No ionisation (flame) signal during start-up procedure	<ul style="list-style-type: none"> • No gas supply <ul style="list-style-type: none"> – gas tap closed – gas valve defective – gas valve's electrical connection loose or improperly connected • Air supply obstructed • Flue tube obstructed • Siphon obstructed • Ionisation cabling not in order • Ionisation probe defective or causing short-circuit such as against burner • No ignition <ul style="list-style-type: none"> – ignition transformer electrical connection loose or improperly connected – power cable defective – ignition electrode defective or causing short-circuit • Control unit
4	Ionisation signal lost during heat supply (diagnostic code 1 - 4)	<ul style="list-style-type: none"> • Insufficient gas supply • Siphon obstructed • Ionisation electrode defective / causing short-circuit such as against burner • Gas valve set incorrectly • O₂ content more than 7.5% at low setting • Fan's low capacity circuit defective or interrupted • Burner damaged • Control unit
4.	Ionisation signal remains too long after heat supply	<ul style="list-style-type: none"> • Valve in gas valve defective, remains open or leaks • Control unit
6	Gas valve control receiving voltage erroneously	<ul style="list-style-type: none"> • Wiring error • Control unit

Malfunction messages (continued)

Code	Diagnosis	Cause
Diagnostic display		
7	Insufficient circulation of central heating water during hot water heating	<ul style="list-style-type: none"> • Insufficient central heating water in the central heating water circuit <ul style="list-style-type: none"> - Central heating water pressure too low (minimum 1 bar at the appliance) -Automatic de-aerator not functioning properly (air in the appliance) • Central heating pump not running <ul style="list-style-type: none"> - Central heating pump stuck - Connector K5 loose - Central heating pump defective - Thermal safety switched off - Control unit
7.	Insufficient circulation of central heating water during radiator heating	<ul style="list-style-type: none"> • Insufficient central heating water in the central heating water circuit <ul style="list-style-type: none"> - Central heating water pressure too low (minimum 1 bar at the appliance) - All (thermostat) radiator taps are closed (pressure difference regulator not set properly if present) - Accumulation of air caught somewhere in the central heating water circuit -Automatic de-aerator not functioning properly (air in the appliance) • Central heating pump not running <ul style="list-style-type: none"> - Central heating pump stuck - Connector K5 loose - Central heating pump defective - Control unit
8	High limit thermostat switches off and central heating water pressure lower than 0.5 bar	<ul style="list-style-type: none"> • Central heating water pressure incorrect • Central heating water temperature sensor not properly connected to central heating water pipe • Thermal safety connection defective • Thermal safety defective • Control unit • Central heating pump not running <ul style="list-style-type: none"> - Central heating pump stuck - Connector K5 loose - Central heating pump defective - Control unit
9	High limit thermostat switches off and temperature of central heating water sensor exceeds 80°C	<ul style="list-style-type: none"> • Central heating water temperature sensor not properly connected to central heating water pipe • Thermal safety connection defective • Thermal safety defective • Control unit • Central pump not running <ul style="list-style-type: none"> - Central heating pump stuck - Connector K5 loose - Central heating pump defective - Control unit
9.	Control unit safety malfunction	<ul style="list-style-type: none"> • Control unit
LETTER	[Letter such as A or E] Internal error in control unit.	<ul style="list-style-type: none"> • Control unit
[Dark display]	Appliance not receiving any power	<ul style="list-style-type: none"> • Plug not inserted in wall socket • No electricity from wall socket • Wire loom connector k6 not connected • Control unit fuse defective • Mains voltage wiring defective • Control unit

4. USER PROGRAM

The user program is identified by a permanently lit letter followed by a dot.

- Access : Press 'Set' button for approx. 5 seconds until the letter **b.** appears
- Next setting : Press 'Set' button
- Different value : Press 'Hot water' button
- Exit program : Press 'Reset' button

Code		Function	Setting
Diagnostic display	Central heating water display		
b.	0 1	Hot water tank temperature	60°C
	0 2		*65°C
	0 3		70°C
C.	8 8	Central heating temperature	°C
	0. 0	Central heating pressure sensor is not active	
	8. 8	Central heating pressure	*BAR
F.	8 8	Serial number + last malfunction	
G.	8 8	Serial number + last blocking	
0.**	0 0	Weather-dependent regulation	*Off
	0 1		Room thermostat
	0 2		Timer switch
S.	0 0	Non-standard setting (only applies to User program)	
	0 1	Return to standard* (only applies to User program)	

* standard

** only visible if outside temperature sensor is connected

5. INSTALLER PROGRAM

The Installer program is identified by a permanently illuminated letter without a dot.

- Access : Press 'Set' button for approx. 10 seconds until the letter **A** appears
- Different value : Press 'Hot water' button
- Next setting : Press 'Set' button
- Exit program : Press 'Reset' button
- To sub-program : Press 'Set' button followed by 'Hot water' button

Code		Function	Setting
Diagnostic display	Central heating water display		
A	8 8	Fictitious ionisation flow	
	L L	Low capacity (continuous)	
	H H	High capacity (continuous)	
b	5 b	To sub-mode sensor values	
c	0 0	Modulate at central heating temperature	Off
	1 1		*On
C	6 0	Central heating water temperature (maximum)	60°C
	7 5		75°C
	9 0		*90°C
E	0 0	Three-way valve capacity control	Off
	1 1		*On
F	8	Malfunctions (maximum 15)	Begin/end
	8 8	- 8 = service identification number (0 - 6)	Last malfunction code
	8 8	- 8 = malfunction code	Last malfunction code -1
	8 8		etc.
G	8	Blocks (maximum 16)	Begin/end
	8 8	- 8 = service identification number (0 - 6)	Last blocking code
	8 8	- 8 = blocking code	Last blocking code -1
	8 8		etc.

* standard

Code		Function	Setting
Diagnostic display	Central heating water display		
h	0 1	Pump over-run for central heating	* 1 min.
	0 3		3 min.
	0 5		5 min.
H	0. 1	Pump over-run for boiler	*10 min.
	0. 2		20 min.
	0. 3		30 min.
	0. 4		40 min.
	1. 0		1 hour
	2 4		Continuous
L	0 0	Low capacity burner time	off
	0 5		5 min.
	1 0		* 10 min.
	1 5		15 min.
n	0 0	Central heating acceleration	off
	0 2		2 min.
	0 5		5 min.
	1 0		*10 min.
0**	5 b	To sub-program weather-dependent setting	Last blocking code
P	0 0	Anti-cycling central heating	off
	0 3		*3 min.
	0 6		6 min.
Q	5	Frost-protection (internal on central heating water)	5°C
	1 0		*10°C
	1 5		15°C
	2 0		20°C
S	0 0	Non-standard setting (only applies to service program)	
	1 1	Return to standard (only applies to service program)	
t***	1 0	Appliance recognition 24/80	
	1 1	Appliance recognition 24/80 ^{plus}	
	2 0	Appliance recognition 32/80	
	2 1	Appliance recognition 32/80 ^{plus}	
	3 1	Appliance recognition 38/80 ^{plus}	
Y	7	Capacity limitation for central heating supply 24/80 and 24/80 ^{plus}	7.5 kW
	1 5		15 kW
	2 4		*24.5 kW
	1 0	Capacity limitation for central heating supply 32/80 and 32/80 ^{plus}	10 kW
	2 1		21 kW
	3 2		*32 kW
	1 1	Capacity limitation for central heating supply 38/80 ^{plus}	11 kW
	2 4		24 kW
3 8	*38 kW		

* standard

** only visible if outside temperature sensor is connected

*** with the proper selection, the code **t** will not be visible in the service program

6. SERVICE SERIAL NUMBER

Every malfunction is preceded by a service identification number. The service identification number is a handy tool for servicing the *ATMOS MULTI*. By changing this number after every service, the next time, one can see which blocks and/or malfunctions occurred since the last service.

To change the service identification number, the malfunction logbook **F** must first be selected. Then the 'Hot water' button is kept pressed in while finally the 'Set' button is pressed.

The service identification number will be increased by 1 to a maximum of 6, and will then start again from the number 0. When changing the service identification number, it is simultaneously changed in the blocking logbook.

The example below shows the logbook codes in the CH Water display, obtained by stepping through the most recent logged faults using the 'Hot water' button.

Example		DIAGNOSIS	CENTRAL HEATING WATER DISPLAY			
•	OCT '05 INSTALLATION OF THE APPLIANCE – CONTENTS OF MALFUNCTION LOGBOOK – CONTENTS OF BLOCKING LOGBOOK	F G	0- 0-			
•	OCT '06 ANNUAL INSPECTION – CONTENTS OF MALFUNCTION LOGBOOK – CONTENTS OF BLOCKING LOGBOOK – SERVICE ID NUMBER INCREASED BY MEANS OF 'HOT WATER' AND 'SET' BUTTON	F* G**	0- 0- 0-	07. 0c 1-	07. 0- 07	0- 0- 07
•	OCT '07 ANNUAL INSPECTION – CONTENTS OF MALFUNCTION LOGBOOK – CONTENTS OF BLOCKING LOGBOOK – SERVICE ID NUMBER INCREASED BY MEANS OF 'HOT WATER' AND 'SET' BUTTON	F*** G	1- 1- 1-	13. 0c 2-	07. 1- 07	07 07 1-

* Two times **07.** means insufficient central heating water flow during central heating operation.

** One **0c** means for example that the central heating water temperature connector was loose.

*** Malfunction **13** was added in the second year. This can be seen by the first number **1** (service identification number). The second number **3.** is the malfunction (in this case no ionisation signal during start-up procedure). The two last malfunctions are preceded by a different service number and are therefore from the previous services.

COMMENT!

Do not forget to increase the service identification number after each service/maintenance and record this with the date on the service chart of the appliance.

SERVICE RECORD

It is recommended that your heating system is serviced regularly and that the appropriate Service Record is completed.

Service Provider

Before completing the appropriate Service Record below, please ensure you have carried out the service as described in the manufacturer's instructions.

Always use the manufacturer's specified spare part when replacing controls.

SERVICE 1 Date _____

Energy Efficiency Checklist completed? Yes No

Engineer Name _____

Company Name _____

Telephone Number _____

CORGI ID Number _____

Comments _____

Signature _____

SERVICE 2 Date _____

Energy Efficiency Checklist completed? Yes No

Engineer Name _____

Company Name _____

Telephone Number _____

CORGI ID Number _____

Comments _____

Signature _____

SERVICE 3 Date _____

Energy Efficiency Checklist completed? Yes No

Engineer Name _____

Company Name _____

Telephone Number _____

CORGI ID Number _____

Comments _____

Signature _____

SERVICE 4 Date _____

Energy Efficiency Checklist completed? Yes No

Engineer Name _____

Company Name _____

Telephone Number _____

CORGI ID Number _____

Comments _____

Signature _____

SERVICE 5 Date _____

Energy Efficiency Checklist completed? Yes No

Engineer Name _____

Company Name _____

Telephone Number _____

CORGI ID Number _____

Comments _____

Signature _____

SERVICE 6 Date _____

Energy Efficiency Checklist completed? Yes No

Engineer Name _____

Company Name _____

Telephone Number _____

CORGI ID Number _____

Comments _____

Signature _____

SERVICE 7 Date _____

Energy Efficiency Checklist completed? Yes No

Engineer Name _____

Company Name _____

Telephone Number _____

CORGI ID Number _____

Comments _____

Signature _____

SERVICE 8 Date _____

Energy Efficiency Checklist completed? Yes No

Engineer Name _____

Company Name _____

Telephone Number _____

CORGI ID Number _____

Comments _____

Signature _____

SERVICE 9 Date _____

Energy Efficiency Checklist completed? Yes No

Engineer Name _____

Company Name _____

Telephone Number _____

CORGI ID Number _____

Comments _____

Signature _____

SERVICE 10 Date _____

Energy Efficiency Checklist completed? Yes No

Engineer Name _____

Company Name _____

Telephone Number _____

CORGI ID Number _____

Comments _____

Signature _____

