

SECTION 1: USE AND MAINTENANCE

GENERAL WARNINGS

- This manual is an integral and essential part of the product and must be given to the user.
- **Qualified service engineers are those having specific technical experience in the field of heating installation unit for home use.**
- This unit must be exclusively used for the purpose it was intended. Any other use is to be considered improper and therefore dangerous.
The manufacturer will not be held responsible for damages resulting from installation errors or failure to comply with the manufacturer's instructions.
- Do not obstruct the fan intake opening or the air delivery grilles.
- In case of failure and/or poor operation, isolate the unit (disconnect it from the power supply and close the gas cock), do not attempt any repair or direct servicing.

Call qualified service engineers only.

Any repair to the products must only be carried out by the manufacturer's authorised service centres using only original spare parts.

Misapplication of the above might compromise the safety of the unit.

To ensure unit efficiency and correct operation, it is essential that **qualified service engineers** carry out annual maintenance following the manufacturer's instructions.

- Should the unit be sold or transferred to another owner, please ensure that the manual remains with the unit for use by the new owner and/or installer.

Before turning on the heater, a **qualified service engineer** must check:

- that electric and gas supply ratings are the same as those given in the data plate.
- that the exhaust duct operates correctly.
- that combustion air feed and exhaust occur correctly according to the existing standards.
- the internal and external seal of the combustion unit.
- fuel flow control according to the heater's power requirements.
- that the heater is fed with the type of fuel for which it is pre-set.
- that the gas supply pressure is within rating limits.
- that the gas supply system is suitable to the heater and all safety and check-over devices prescribed by existing standards are duly installed.
- Do not use gas pipes to earth electrical apparatus.
- Avoid unnecessary supply when unit is not in use and always close the gas cock.

WARNING : If you smell gas:

- do not operate electric switches, telephones or any other object or device which may cause sparks
- open immediately doors and windows to create a cross-current of air to purify the room;
- shut-off the gas supply
- call for a qualified service engineer

UNIT OPERATION

- The heater operation is controlled by a room thermostat, (not supplied with the unit). When the thermostat is activated, the electronic flame control unit will cause ignition of the main burner. A ionization sensor checks that ignition has occurred.
- The products of combustion flow through the heat exchangers and, after meeting an air current produced by the axial-flow fan, deliver heat in the room.
- The air flow direction is regulated by means of adjustable grille vanes. A "vertical vane kit" is also available on request for horizontal regulation of the air flow.
- The fan control thermostat allows the axial-flow fan to start automatically only when the heat exchangers are hot and to turn off when they are cold. This prevents cool air being blown into the room.

- If heat exchangers overheat due to malfunction, a temperature limit thermostat cuts off the supply to the gas valve, thus interrupting fuel flow and turning off the main burner.

NOTE

Resetting of the temperature limit thermostat should be carried out by qualified service personnel, after removing the cause of overheating.

- The exhaust manifold is connected to a flue fan by a flexible aluminium tube. This provides forced expulsion of combustion products.
- In case of obstructions in the intake duct or flue fan malfunction, a differential pressure switch closes the gas valve and consequently stops fuel flow to the burner.
- If you wish to use only the fan during summertime, move the shunt summer/winter (see Figure 19, page 24). In this way, the burner will remain switched off while the fan will work continuously giving a pleasant and refreshing air movement in the room. It is possible to replace the shunt with a switch: contact your installer.

STARTING AND STOPPING THE UNIT**WARNING**

The first start-up should be carried out by *a qualified service engineer* **Before turning the unit on, a qualified service engineer must check:**

- that unit ratings are the same as the ones for electric and gas supply;
- that the flue outlet and air inlet ducts operate correctly and are installed according to the requirements of the existing standards.

Winter

- 1) Set the room thermostat to the highest temperature.
- 2) Check that the gas cock is open.
- 3) Supply the unit with electric power by closing the omnipolar switch.
- 4) After the pre-purge period (about 30 seconds), the gas solenoid valve opens and the ignition electrode begins to sparkle for a maximum period of 5 seconds.
- 5) When the flame is ignited, the flame sensor automatically interrupts the spark while the unit continues to function.
- 6) Otherwise the flame control unit locks out the heater: the gas supply to the burner is shut off and a lock-out light on the reset button is turned on.
- 7) Should this happen (point 6), press the reset button.
- 8) If ignition has occurred smoothly, set the room thermostat to the desired temperature.
- 9) After some minutes, the fan will start blowing warm air into the premise.

WARNING

After a long period of unit inactivity or at the first start-up, it may be necessary to repeat the ignition operation a few times due to the presence of air in the piping.

Turning off the unit

- To turn off the unit, set the room thermostat to the lowest temperature. The burner is turned off, while the fan will continue to operate until the unit is completely cold.

WARNING

It is not good practice to turn the unit off by disconnecting the electric power supply, as this may damage the unit. In fact, this causes the immediate stop of the fans, unit overheating and possibly the activation of the temperature limit thermostat.

NOTE

In case of long inactivity, after carrying out the above operation and after the fans have turned off, close the gas cock and disconnect the electric supply by using the omnipolar switch placed on the supply line.

Summer

- Close the gas cock and disconnect the unit from the electric power supply by mean of the omnipolar switch.
- Move the electrical shunt in the control panel to the summer position (see Figure 19 on page 24). Close the control panel and turn the omnipolar switch on. In this way, only the fans will operate. If you prefer, ask your installer to replace the shunt with a switch (see Figure 20 on page 25).

MAINTENANCE

To ensure adequate and long-lasting functioning, it is advisable to carry out a general unit cleaning once a year, taking particular care of cleaning the heat exchangers and the fan grilles, which should be externally brushed.

Adequate maintenance ensures safety and savings.

AFTER-SALES SERVICE**WARNING**

For all installation operations, start-up, gas changes, etc. always consult a qualified service engineer.

If in doubt contact Robur S.p.A. on +39-035-888111.

Before calling for service, make sure the unit technical data and manual is within reach and namely:

- product serial no.
- gas supply pressure and type
- burner pressure
- a brief description of the installation type

TECHNICAL SPECIFICATIONS

UNIT MODEL			20	25	30	35	40	50	60
Unit category			II2H3+						
Unit type			C ₁₂ - C ₃₂ - B ₂₂						
Nominal heat input (*)		kW BTU/h	20.6 70300	28.8 98200	34.8 118700	42.2 144000	48.2 164400	57.3 195500	72.5 247300
Nominal heat output		kW BTU/h	18.3 62500	25.5 87000	30.7 104800	37.4 127600	42.5 145000	50.7 173000	63.8 217700
Gas consumption (15°C - 1013 mbar)	Natural gas	m ³ /h	2.18	3.04	3.68	4.46	5.10	6.06	7.67
	L.P.G. G30 (butane)	kg/h	1.62	2.27	2.74	3.32	3.80	4.52	5.72
	L.P.G. G31 (propane)	kg/h	1.59	2.22	2.69	3.26	3.73	4.43	5.61
Efficiency (*)		%	88.8	88.5	88.2	88.6	88.8	88.5	88
Supply pressure	Natural gas L.P.G. G30 (butane) L.P.G. G31 (propane)	mbar (psig) [in.w.c]	20 (0.29) [8.03] 30 (0.43) [12.04] 37 (0.53) [14.85]						
Gas inlet diameter		inch	1/2				3/4		
Air pipe diameter		mm	130						
Exhaust pipe diameter		mm	110						
Voltage supply			230-240V - 50 Hz						
Installed power		W	340				400	620	
Safety fuse		A	4						
Air flow		m ³ /h	1700	2350	3000	3400	3750	4700	6200
Thermal head		K	32	32	30.3	32.6	33.6	32	30.5
Length of throw (residual speed >1m/s)		m	12	15	18	20	21	23	25
Sound level at 6 m	in free field	dB(A)	41	43	44	44	45	45	47
	in a typical installation		53	55	56	56	57	58	59
Weight		kg lbs	55 121	59 130	68 150	80 176	80 176	90 198	108 238

■ Table 1

 (*) DATA REFERED TO THE NET CALORIFIC VALUE (9,45 kWh/m³ – 15°C 1013 mbar).

DIMENSIONS

	20	25	30	35	40	50	60
A	630	630	770	880	880	1070	1270
B	640	640	670	670	700	640	670
C	800	800	800	800	800	800	800
D	490	490	490	490	490	490	490
E	370	370	510	620	620	810	1010
F	405	405	405	405	405	405	405
G	440	440	580	690	690	880	1080
H	430	430	430	430	430	430	430
J	215	215	215	215	215	215	215
L	285	285	285	285	285	285	285
M	310	310	310	310	310	310	310
N	95	95	95	95	95	95	95
P	390	390	460	515	515	398	468
Q	435	435	435	435	435	435	435
R	340	340	340	340	340	340	340
S	600	600	600	600	600	600	600
T	715	715	715	715	715	715	715
U	714	714	714	714	714	714	714
V	1/2	1/2	1/2	1/2	3/4	3/4	3/4
W	/	/	/	/	/	432	495
X	113	113	113	113	113	113	113
Y	133	133	133	133	133	133	133
Z	355	355	410	410	410	355	410

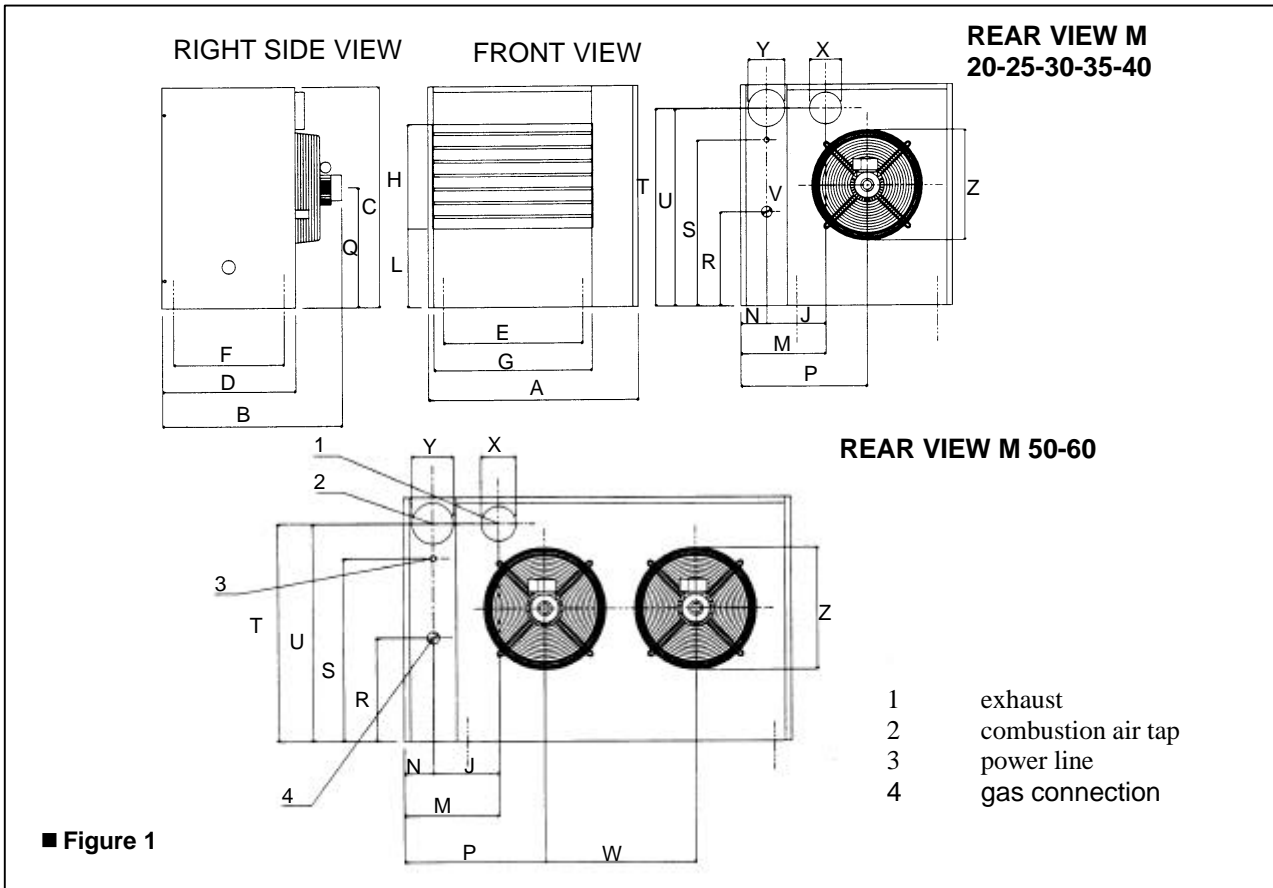
Table 2

SECTION 2: INSTALLATION

GENERAL RULES FOR UNIT INSTALLATION

WARNING

- The installation must be carried out by a qualified service engineer following the manufacturer's instructions.
- Qualified engineer means those having specific technical competence according to CORGI Register.
- An incorrect installation can cause damages to people, animals and property. In case of erroneous installation, the manufacturer cannot be held responsible for such damages.
- Comply with all existing standards and in particular CORGI regulations.

According to the installation project, install the gas supply lines, the electric power lines and a suitable support bracket for the unit.

Installation procedures should be as follows:

- A) Unpack the unit, carefully checking that it has not been damaged. Every unit is factory tested before shipment, therefore, if there are damages, report them immediately to the carrier.
- B) The minimum distance from the wall behind the unit must be enough for air circulation. The minimum distance from the lateral walls is given in Figure 2 (350 mm).
- C) The recommended height from the floor to the heater base is 2.5 to 3.5 m.
- D) A gas cock and a pipe union must be provided for gas supply.
- E) Make sure that an adequate gas supply from the gas network is provided, particularly if the unit is fed with:

Natural gas:

Be sure that the pressure of the gas network, with the unit in operation, is set at 20 mbar (0.29 psig, 8.03 in.w.c.) allowed tolerance between 17 and 25 mbar (0.25 to 0.36 psig; 6.9 to 10.0 in.w.c.).

L.P.G.:

For the first pressure drop required in the supply, it is advisable to install a pressure governor near the liquid gas tank so as to reduce the pressure to 22 psig (1.5 bar). A pressure governor for a second pressure drop should be placed near the heater to reduce the pressure to 30 mbar (0.43 psig; 12.0 in.w.c.) allowed tolerance between 20 and 35 mbar (0.29 to 0.50 psig; 8.1 to 14 in.w.c.).

- F) Carry out the electrical connections according to the installation wiring diagram on page 24, checking that the voltage supply is 230-240V/50Hz single-phase. For this operation make sure that:
 - wire type is H05 VVF 3x1 mm² with a maximum external diameter of 8.4 mm.
 - when connecting, ensure that the earth wire is longer than the live wires, so that it will be the last wire to break if the supply cable is stretched, thus ensuring a good earth continuity.

NOTE

The electrical safety of the unit is attained only when the unit itself is correctly connected and efficiently earthed according to the existing safety standards. Do not use gas tubes to earth electrical apparatus.

- G) The unit should be connected to the electric supply line by means of an omnipolar switch with a minimum contact opening of 3 mm. An omnipolar switch is a "Double pole isolating switch", i.e. a switch capable of disconnecting both on phase and neutral. This means that when the switch is opened, both contacts are disconnected.
- H) The summer/winter shunt may be replaced with a switch if desired (Fig. Figure 20, on page 25). This summer/winter switch is available as an optional.
- I) It is mandatory to install a room thermostat connected to the unit according to the installation wiring diagram (Figure 19, page 24). It is recommended to place the sensor at about 1.5 m from the floor, protected against air draughts, direct exposure to sun rays and direct heat sources (lamps, hot air flows from the unit itself, etc.). If possible, DO NOT place the thermostat on walls bordering the outside, to avoid false temperature readings and therefore system operation. IF THE ROOM THERMOSTAT IS

PROPERLY INSTALLED, UNWANTED STARTING AND STOPPING OF THE SYSTEM WILL BE AVOIDED AND ADEQUATE ROOM COMFORT WILL THUS BE ENSURED.

- J) To obtain the maximum system efficiency it is advisable to comply with the following rules:
- Install units as close as possible to the work area, taking care that the air flow does not directly come into contact with people.
 - Take obstacles into consideration (columns, etc.)
 - For better heat distribution in the case of multiple unit installation, create alternate flows of hot air (see Figure 3).
 - In some cases it may also be suitable to place the units close to the main doors, so that they can also operate as air barriers when doors are opened.

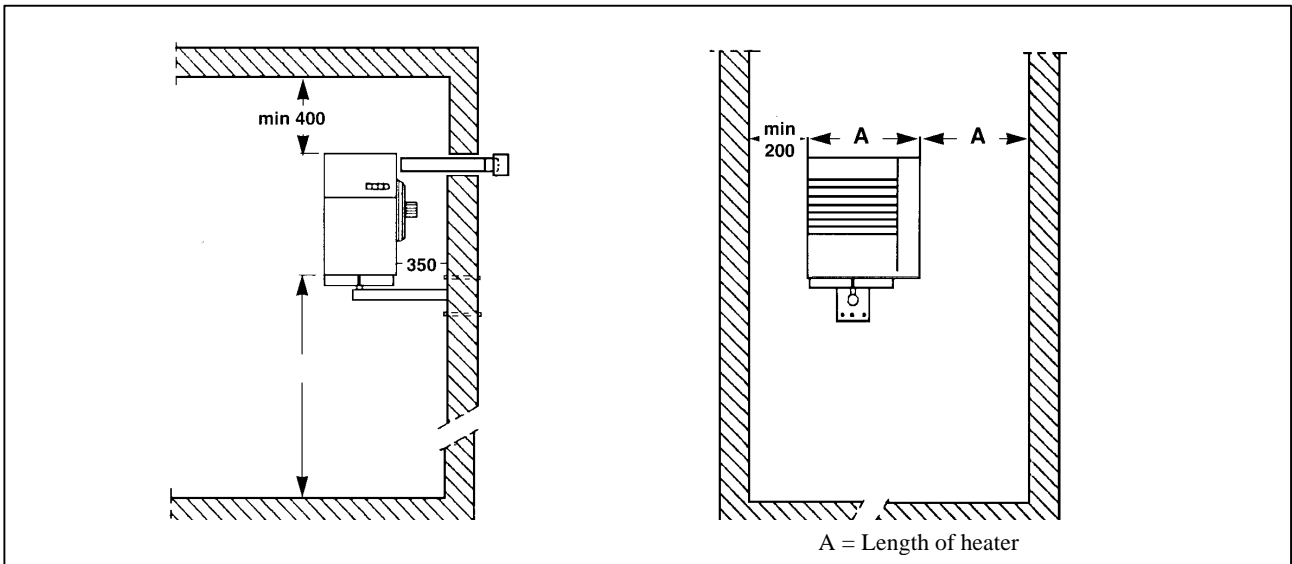

■ Figure 2

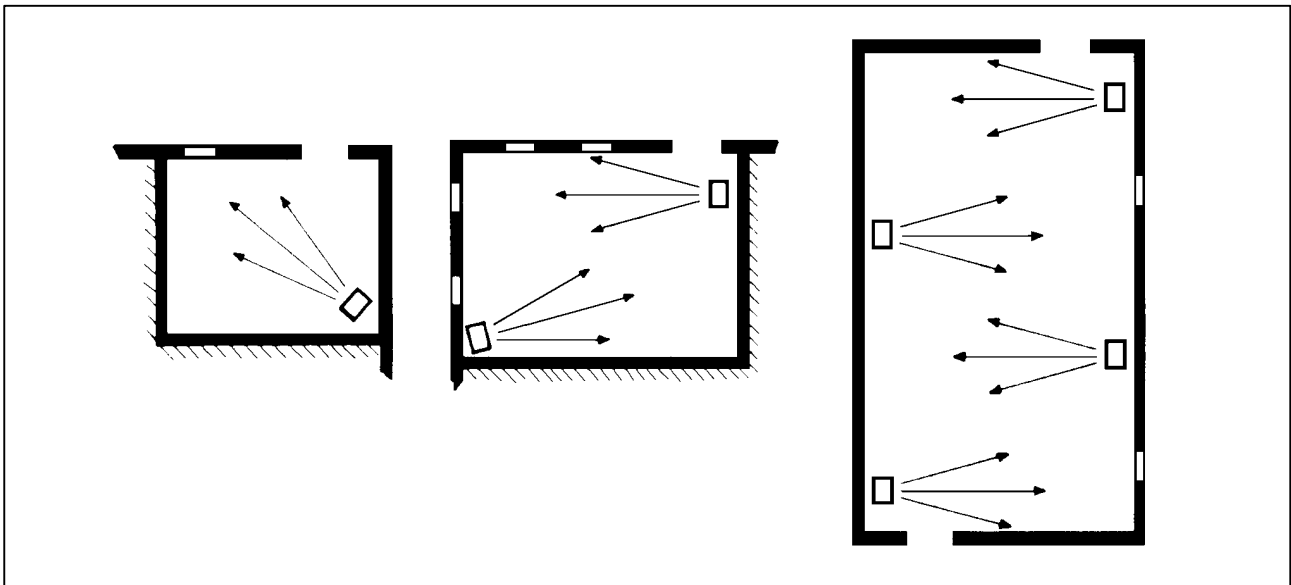

■ Figure 3

SIZE AND INSTALLATION OF THE AIR INLET/FLUE EXHAUST

Warm air unit heaters of the M Series can be installed to one of the following options:

- installation type **C12** : combustion products' exhaust and combustion air intake occur by means of either coaxial or separate horizontal flues. The unit is fully air-tight within the environment in which it is installed. Some examples are given in Figure 4 and Figure 5.
- installation type **C32** : combustion products' exhaust and combustion air intake occur by means of either coaxial or separate vertical flues. The unit is fully air-tight within the environment in which it is installed (see Figure 8).
- installation type **B22** : combustion products' exhaust is made outside the room in which the unit is installed; the air required for combustion is directly taken from the room (see Figure 6). However, this type of installation does not permit an air-tight system to be obtained, and for this reason this installation can **ONLY** be made in well-ventilated spaces.

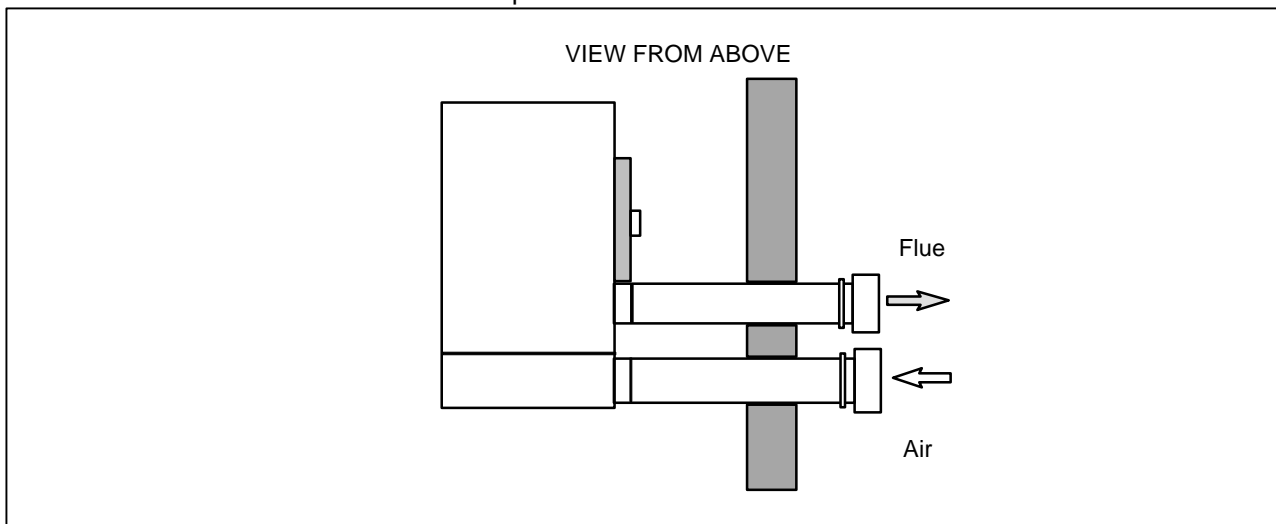

■ **Figure 4**
INSTALLATION TYPE C12 WITH SEPARATE DUCTS

In any case, use approved ducts according to the type of installation to be made. Upon request, Robur S.p.A. can supply rigid pipes, coaxial ducts and terminals, all of approved type.

To obtain a correct size of the flue system, the total resistance of the flue system needs to be calculated.

The total amount of resistance allowed in the flue system depends on the unit model, the flue diameter and the diaphragm installed in the unit.

Table 3 shows the maximum allowed resistance for each unit and the relevant diaphragm installed. Table 4 shows the resistance of the exhaust and air intake flues.

Resistance from the coaxial terminals are shown in Table 5.

Resistance from the separate terminals are negligible since they are very low.

When designing, flues should be selected after having checked that the total amount of the flue system resistances are within the minimum and the maximum resistance allowed for the unit (see Table 3).

NOTE

If horizontal pipes having lengths above 1 metre are installed, the flue pipe must be mounted with a slope of 2 to 3 cm each 1 metre length (see Figure 9), to prevent that condense drops entering the unit. In addition, to install the external flue exhaust terminals and the air intake terminals correctly, follow the details given in Figure 7.

NOTE

Note: If vertical pipes with lengths above 3 metres are installed, at the base of the vertically mounted flue pipe a T-shaped piece should be fitted to collect the condense, to prevent any condense drops entering the unit.

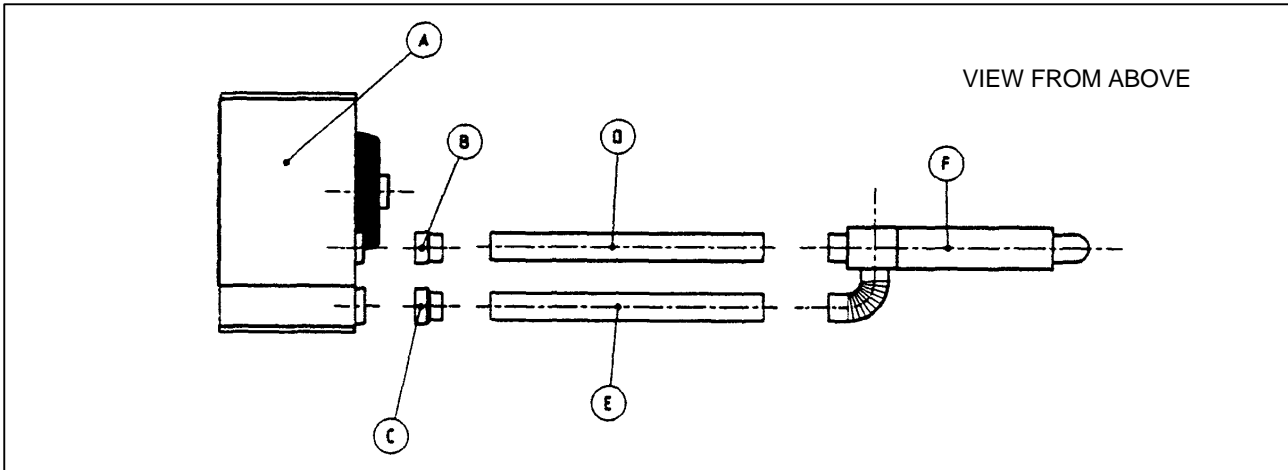

■ **Figure 5**
INSTALLATION TYPE C12 WITH Ø 130 COAXIAL TERMINAL

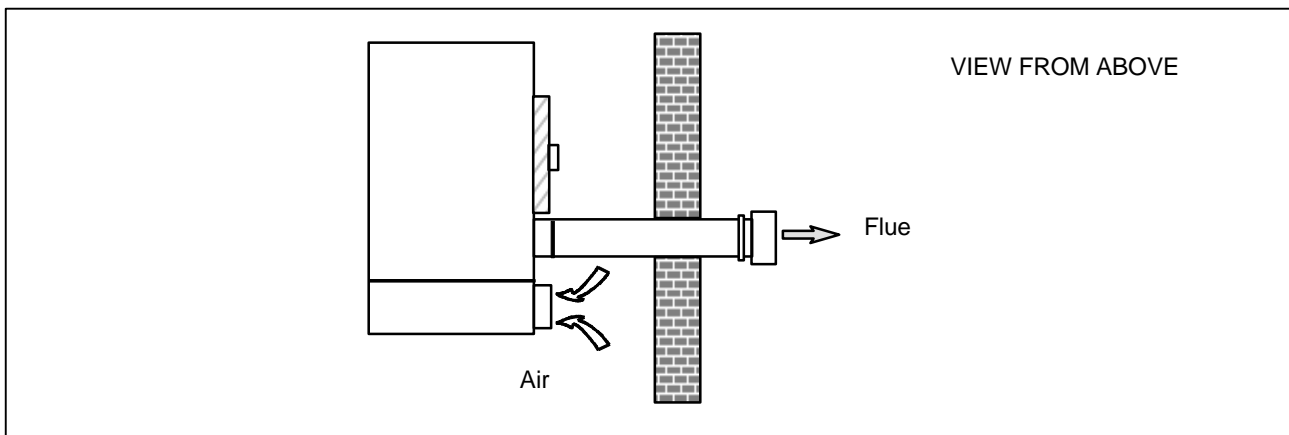

■ **Figure 6**
INSTALLATION TYPE B22

Model	Air diaphragm		Flue diaphragm		Max. resistance allowed (Pa)	Min. resistance allowed (Pa)
	height (mm)	part no.	height (mm)	part no.		
M 20	----	----	60	019	40	----
M 25	----	----	----	----	30	12
	----	----	45	012	16	----
M 30	84	007	----	----	35	23
	84	007	55	013	25	----
M 35	----	----	----	----	42	25
	----	----	40	014	24	10
	----	----	50	020	12	----
M 40	----	----	----	----	30	19
	----	----	35	026	19	----
M 50	----	----	----	----	27	8
	----	----	35	026	8	----
M 60	----	----	----	----	69	45
	----	----	45	012	46	22
	----	----	55	013	21	----

■ **Table 3**
RESISTANCE ALLOWED ACCORDING TO MODEL AND INSTALLED DIAPHRAGM

Model	Air diaphragm		Flue diaphragm		Flue pipe resistance (Pa/m)			Air pipe resistance (Pa/m)		
	height (mm)	part no.	height (mm)	part no.	Ø 100	Ø 110	Ø 130	Ø 100	Ø 110	Ø 130
M 20	----	----	60	019	0.73	0.46	0.20	0.27	0.17	0.07
M 25	----	----	----	----	1.58	0.99	0.43	0.57	0.36	0.16
	----	----	45	012	1.52	0.95	0.42	0.55	0.34	0.15
M 30	84	007	----	----	1.93	1.21	0.53	0.71	0.45	0.20
	84	007	55	013	1.77	1.11	0.49	0.65	0.41	0.18
M 35	----	----	----	----	3.31	2.07	0.91	1.15	0.72	0.32
	----	----	40	014	3.27	2.04	0.90	1.15	0.72	0.32
	----	----	50	020	3.34	2.09	0.92	1.17	0.73	0.32
M 40	----	----	----	----	4.85	3.03	1.34	1.77	1.10	0.49
	----	----	35	026	4.85	3.03	1.34	1.77	1.10	0.49
M 50	----	----	----	----	4.83	3.02	1.33	1.64	1.03	0.45
	----	----	35	026	4.83	3.02	1.33	1.64	1.03	0.45
M 60	----	----	----	----	N.R.	4.82	2.12	N.R.	1.49	0.66
	----	----	45	012	N.R.	5.49	2.42	N.R.	1.73	0.76
	----	----	55	013	N.R.	5.16	2.27	N.R.	1.66	0.73

N.R. = NOT RECOMMENDED DIAMETER

■ Table 4

RESISTANCES OF THE AIR INTAKE AND FLUE EXHAUST FLUES

NOTE

For each 90° elbow an increment of 1.5 m in length should be added.
 For each T-shaped piece an increment of 2 m in length should be added.
 For each 45° elbow an increment of 0.75 m in length should be added.

Model	Air diaphragm		Flue diaphragm		Resistance of the Ø 100 coaxial duct (Pa)		Resistance of the Ø 130 coaxial duct (Pa)	
	height (mm)	part. no.	height (mm)	part. no.	Wall exhaust		Wall exhaust	Roof exhaust
M 20	----	----	60	019	5.8		2.0	2.2
M 25	----	----	----	----	11.5		4.5	5.1
	----	----	45	012	11.5		4.5	5.1
M 30	84	007	----	----	18.0		5.0	5.6
	84	007	55	013	18.0		5.0	5.6
M 35	----	----	----	----	29.0		9.5	10.7
	----	----	40	014	N.R.		9.5	10.7
	----	----	50	020	N.R.		9.5	10.7
M 40	----	----	----	----	N.R.		10.5	11.8
	----	----	35	026	N.R.		10.5	11.8
M 50	----	----	----	----	N.R.		10.0	11.3
	----	----	35	026	N.R.		10.0	11.3
M 60	----	----	----	----	N.R.		29.5	33.1
	----	----	45	012	N.R.		29.5	33.1
	----	----	55	013	N.R.		N.R.	N.R.

N.R. = NOT RECOMMENDED DIAMETER

■ Table 5

RESISTANCE OF THE AIR INTAKE AND FLUE EXHAUST FLUES

NOTE

Coaxial flues for wall exhaust are **ONLY** available for Ø 100 and 130 models. Coaxial flue for roof exhaust is **ONLY** available for Ø 130 models. All coaxial flue kits include unions to facilitate the connections between flue and unit.

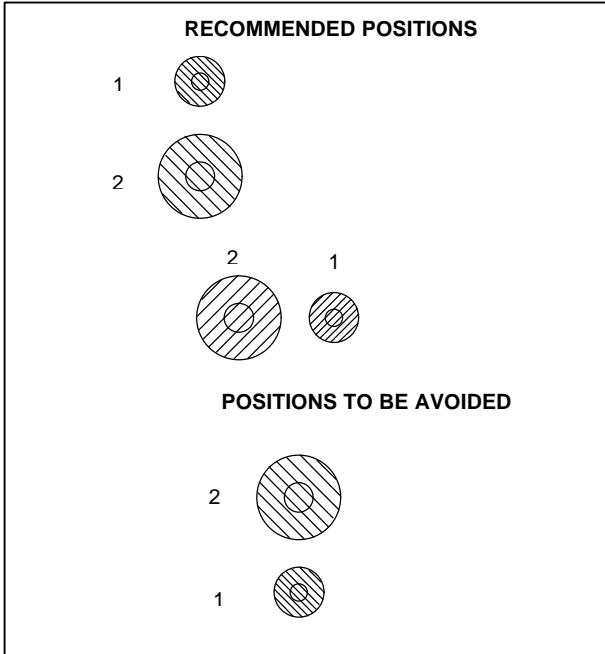

■ **Figure 7**
RECOMMENDED WALL TERMINAL POSITIONS

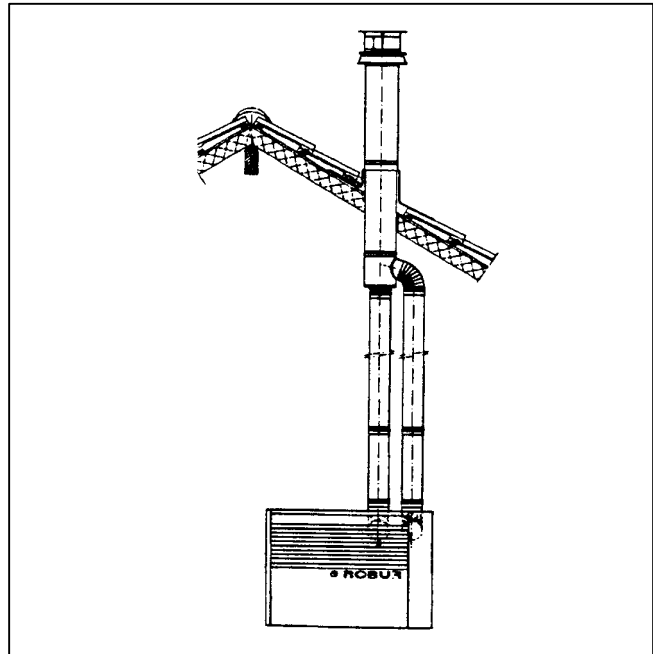

Figure 8
INSTALLATION TYPE C32 WITH COAXIAL TERMINAL

EXAMPLE OF CALCULATION

If a M 35 unit equipped with a 50 mm high flue diaphragm is to be installed, the air/flue system will include the following:

- 3 metres of Ø 100 flue pipe
- 2 90° Ø 100 elbows attached to the flue pipe
- 1 metre of Ø 130 air pipe

Let us calculate the total flue resistance, remembering that the maximum allowed resistance is 12 Pa.

	Q.ty	Resistance		
Ø 100 flue pipe	3	x 3.34 Pa	=	10.02 Pa +
90° elbows	(2x1.5)	x 3.34 Pa	=	10.02 Pa +
Ø 130 air pipe	1	x 0.32 Pa	=	0.32 Pa
Total resistance				20.36 Pa

The total resistance of the flue system is GREATER than the maximum allowed resistance (i.e. 20.36 is GREATER than 12 Pa) and then this installation is UNSUITABLE.

This flue system can only be installed if one of the following steps is taken:

- fit a flue diaphragm 40 mm high: this will increase the allowed resistance of the unit to 24 Pa
- use the Ø 130 flue pipe
- reduce the length in metres of the flue duct

In this case the flue diaphragm cannot be removed, as this will result in the total resistance of the flue system to be lower than the minimum friction loss allowed for the unit.

NOTE

If the total length of the flue system exceeds 16 metres, it is advisable that the local Robur agent is contacted.

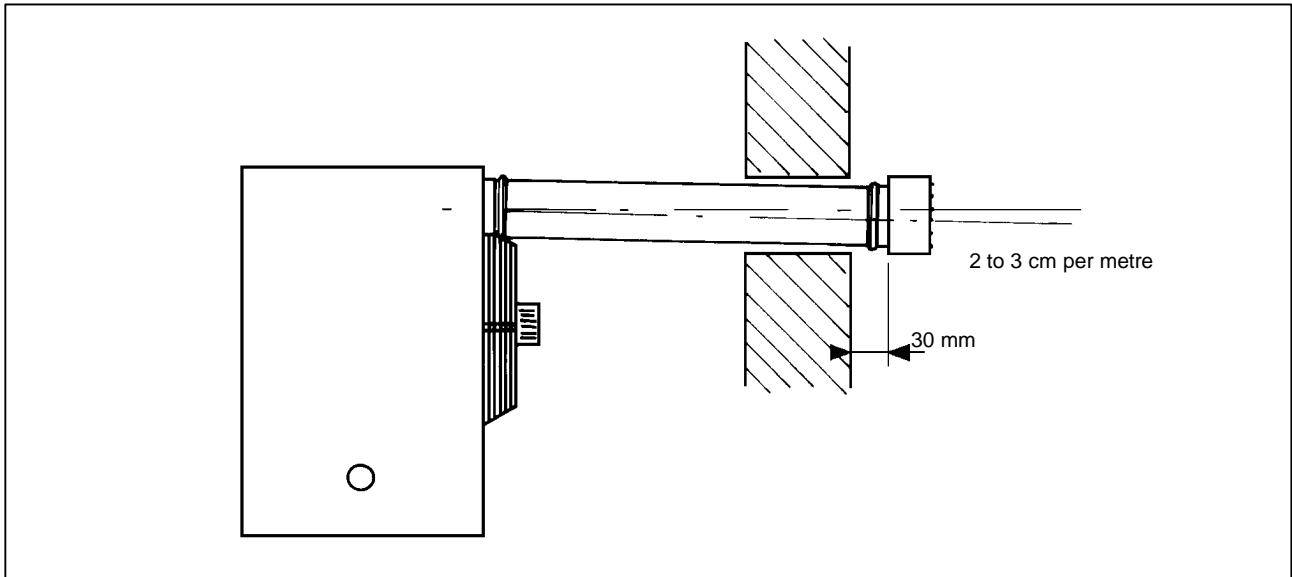

■ **Figure 9**
SLOPE OF THE HORIZONTAL FLUE

INSTALLING THE FLUE DIAPHRAGM

The installation/replacement of the diaphragm is possible on models M 25, 30, 35, 40, 50 and 60. To install/replace the diaphragm the following procedure applies:

- Check that the power supply is turned off.
- Open the electrical panel door.
- Loosen the screw which secures the cover (see Figure 10).
- Remove the cover.
- Undo the two lower screws which secure the flue fan and loosen the two upper screws.
- Insert the flue diaphragm between the flue outlet flange and the flue fan flange, so that the holes in the diaphragm are turned downwards.
- Make the holes in the diaphragm match with the lower holes.
- Tighten the lower and upper flue fan securing screws again.
- Reinstall the cover and tighten the relevant securing screw.

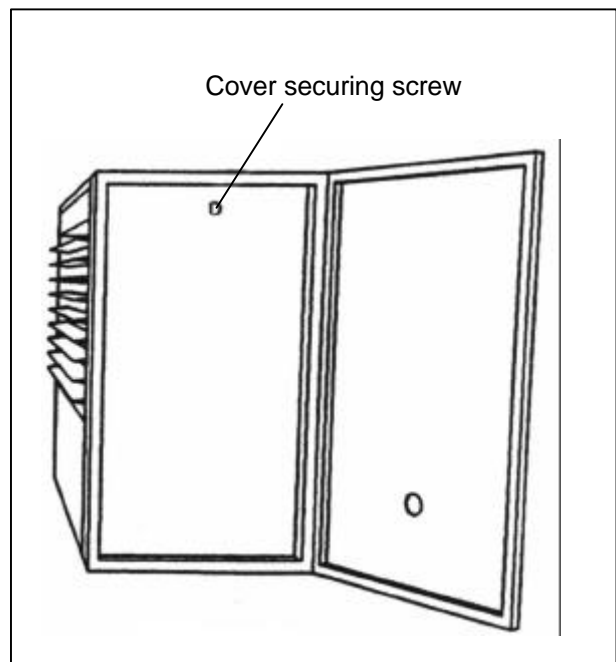

■ **Figure 10**

BRACKET INSTALLATION

Robur S.p.A. supplies an optional, easy-to-install bracket specifically designed for each heater. Should you wish not to use these accessories, please refer to the diagram below. Fasten the unit to the support brackets using four M10 bolts.

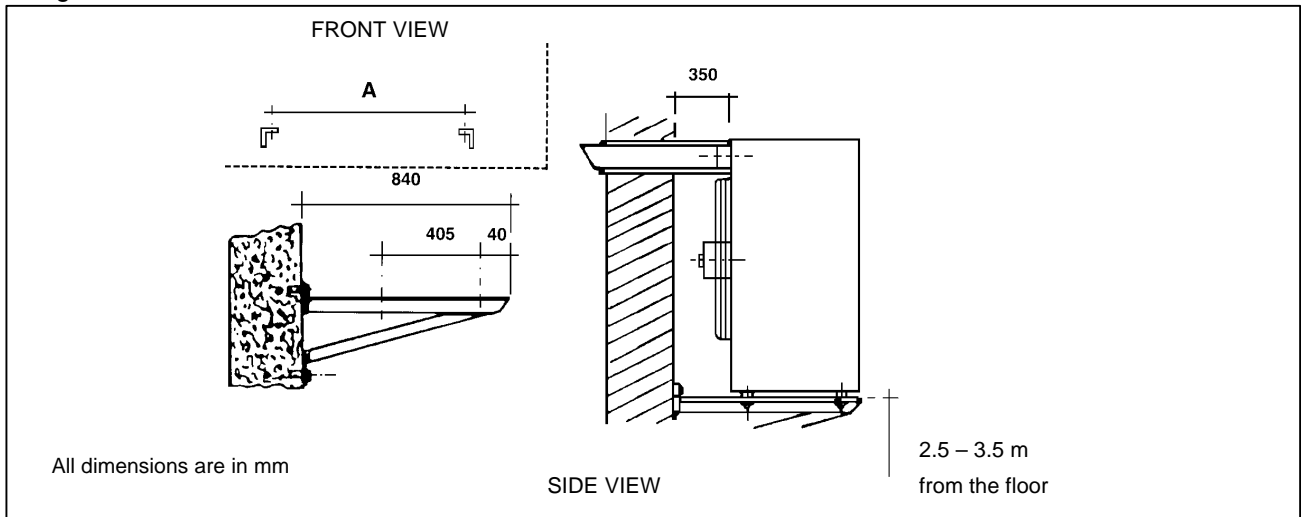

■ Figure 11

Model	20	25	30	35	40	50	60
A (mm)	370	370	510	620	620	810	1010

■ Table 6

CONTROL BOX INSTALLATION

A low-level control box, equipped with lock-out warning lamp and reset button, is supplied with the unit.

WARNING

The operation must be carried out by qualified personnel. Ensure that there is no electric supply during this operation. The cable for this operation must have 1 mm² section for every core.

Installation of the reset button

To install the reset button proceed as follows:

- Isolate the unit from power supply.
- Secure the control box in the desired location using expansion bolts.
- Prepare an adequate length of cable with 3 x 1 mm² section.
- Connect the control box to the cable.
- Connect the cables of the terminal board inside the unit following the indications given in the installation diagram (Figure 19).
- Start the unit.
- Check that, when the gas supply is cut off, the lock out warning light on the control box lights up.
- Then check that the unit restarts and the light goes out when gas is supplied and the reset button is pushed.

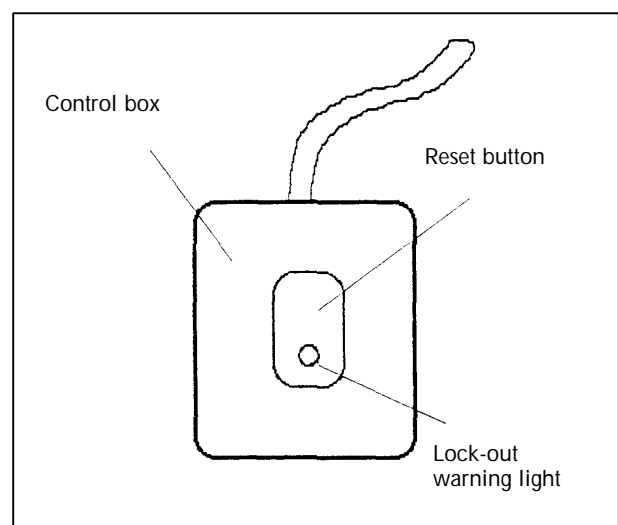

■ Figure 12

NOTE

Before locking-out the unit, a pre-purge and an ignition attempt will be performed.

BURNER PRESSURE ADJUSTMENT

For correct operation, the burner pressure must be as given in Table 7 and Table 8 (on page 14). The burner gas pressure of each unit is set at the factory and is shown by the labels on the package and by a label inside the control panel of each unit. The pressure may be checked at the pressure tap (Figure 13).

WARNING

- After setting the gas pressure, stop and start the unit, and check that burner pressure has stabilised. If necessary perform a new adjustment.
- After completing the gas pressure adjustment, seal the valve setting screw.

SIT 830 Tandem valve (for models 20-25-30-35-40)

(In order to carry out this adjustment, the protection cover must be first removed and re-placed at the end of the operation).

Turn screw A either clockwise (Figure 15, page 21) to increase the pressure or anticlockwise to decrease it, as long as the pressure shown in Table 7 and Table 8 (page 14) is reached.

SIT 826 valve (for models 50-60)

Setting for units fed with natural Gas:

- Remove plastic cover C (see Figure 16, page 21)
- Start the unit
- By way of screw B set burner pressure to the value shown in table Table 7 below (the use of a spanner no. 10 is recommended)
- Adjust then the soft opening pressure (see relevant section).

■ BURNER PRESSURE SETTING TABLE FOR UNITS FED WITH NATURAL GAS (G20) (SUPPLY PRESSURE 20 MBAR)

		20	25	30	35	40	50	60
Burner pressure	(mbar)	11.8	11	7.8	7.4	7.8	9.5	8
	psig	0.17	0.16	0.11	0.10	0.11	0.14	0.12
	in.w.c.	4.75	4.40	3.15	2.95	3.15	3.80	3.20

■ Table 7

Setting for units fed with L.P.G.:

The pressure at the burner is directly related to the supply pressure; be sure to have a supply pressure of 30 mbar. The reduction of the pressure from the mains is possible by using special governors. One governor helps to obtain a first pressure drop down to 1.5 bar close to the fluid gas reservoir and a second governor gives a pressure drop from 1.5 to 0.03 bar at the heater inlet. Proceed then to the soft opening pressure setting (see relevant section).

■ BURNER PRESSURE SETTING TABLE FOR UNITS FED WITH LPG (G30-31) (SUPPLY PRESSURE 30-37 MBAR)

		20	25	30	35	40	50	60
Burner pressure	(mbar)	28.5	28.5	28	28	28	27.5	27.5
	psig	0.41	0.41	0.40	0.40	0.40	0.40	0.40
	in.w.c.	11.45	11.45	11.25	11.25	11.25	11.05	11.05

■ Table 8

SOFT OPENING ADJUSTMENT

WARNING

After pressure setting is ended the valve set screw must be sealed.

SIT 830 Tandem valve

No setting is required.

SIT 826 valve

To adjust soft opening the following procedure applies (also refer to Figure 16):

- Cut-out the SMD coil supply (D). This will make the heater attain the soft opening pressure
- Keeping nut (B) locked in place use screw (A) to set the soft opening pressure to the values shown in Table 9 and in Table 10 (the use of a screwdriver is suggested)
- Replace the plastic cover (C)
- Restore the SMD coil connection (D)

SOFT OPENING SETTING TABLE FOR UNITS FED WITH NATURAL GAS (G20) (SUPPLY PRESSURE 20 MBAR)

		20	25	30	35	40	50	60
Burner pressure	(mbar)	-	-	-	-	-	4.5	4
	psig	-	-	-	-	-	0.065	0.058
	in.w.c.	-	-	-	-	-	1.80	1.60

■ Table 9

SOFT OPENING SETTING TABLE FOR UNITS FED WITH LPG (G30-31) (SUPPLY PRESSURE 30-37 MBAR)

		20	25	30	35	40	50	60
Burner pressure	(mbar)	-	-	-	-	-	18	18
	psig	-	-	-	-	-	0.26	0.26
	in.w.c.	-	-	-	-	-	7.2	7.2

■ Table 10

CONVERSION TO ANOTHER TYPE OF GAS

WARNING

This operation must be carried out by qualified engineers. Wrong and careless assembly of the gas circuit may cause dangerous gas leaks throughout the circuit and especially in the tampered areas. Furthermore, use adequate seals on all connections.

If the type of gas shown on the label does not correspond to the one which will be used, the unit must be converted and adapted to the type of gas you wish to use.

For this operation proceed as follows:

- A) Cut off electricity and gas supply.
- B) Replace nozzles with others having a suitable diameter for the type of gas you intend to use (see Table 11, page 20). Remember also to install the copper washers placed between nozzle and manifold.
- C) Proceed then with the adjustment of the unit, as described in chapter "Burner pressure adjustment".
- D) Replace the label showing the type of gas for which the unit is set with the other one indicating the type of gas actually used. This new label is supplied with the gas conversion kit.

OPERATING FAILURES

Before checking for possible failures, ensure that:

- A) Correct electric supply: 230-240V \pm 10% 50Hz and adequate earthing are provided.
- B) The gas is supplied.
- C) Pressures and flows are within the limits recommended by the manufacturer. A pressure lower than the given limits will result in insufficient gas inlet. The causes for this may be the following:

If the unit is fed with natural Gas:

- a) Poor gas meter performance.
- b) The length of the pipes and the number of elbows are excessive with respect to the diameter.

If the unit is fed with L.P.G.:

- a) It can happen that after the first time the burner turns off, the unit locks out at the moment of ignition. In this case it may be that the reducer flow is insufficient.
- b) If the required pressure is not reached, it may be either that the meter does not provide adequate flow or the length of the pipes and the number of elbows are excessive with respect to the diameter.

Only at this point proceed with the specific trouble shooting.

WARNING

Before opening the side door to access the control panel, CUT OUT THE POWER SUPPLY to the unit using the omnipolar switch.

TYPES OF FAILURES AND SERVICING

In case of a failure, call a qualified service engineer.

CASE NO. 1: THE UNIT LOCKS OUT DURING THE FIRST IGNITION PHASE.

- A) The ignition electrode is broken or badly positioned.
- B) The flame sensor is broken or incorrectly positioned or touches the unit ground.

NOTE

For correct burner ignition, the distance of the ignition electrode from the burner head should be between 4 mm and 6 mm.

- C) Failure in the flame control unit or in its electrical connections.
- D) Failure in the gas valve or in its electrical connections.
- E) Soft opening pressure too low.
- F) Check that the unit has a good earth.
- G) Air is inside the gas pipes.

CASE NO. 2: THE UNIT LOCKS OUT DURING OPERATION.

- A) The gas supply is suddenly cut off due to a failure in the gas system. The ignition control repeats the ignition cycle, after which the gas valve closes locking out the unit (accidental gas inlet cut off).
- B) The power supply is suddenly cut off due to a failure in the electrical supply mains. If the electrical cut off period is prolonged, the temperature limit thermostat (M1) locks out the unit, thus preventing re-ignition. When electricity returns, push the reset button which is placed on the thermostat, inside the unit control panel, below the black screw plug (accidental power supply break).
- C) The flame sensor touches the unit ground or it is disconnected.
- D) The gas valve does not open due to a failure of the valve itself or of its electrical connections.

CASE NO. 3: THE TEMPERATURE LIMIT THERMOSTAT (M1) STOPS THE BURNER.

- A) The heat exchangers have overheated. Check the operation of the fan, gas pressure and nozzles.
- B) The exchangers overheat due to accumulation of dirt. Clean the exchangers (dirt can also obstruct ventilation and supply grille).

To reset the thermostat push the button placed on the thermostat inside the unit control panel, under the black screw plug.

CASE NO. 4: THE BURNER GOES OUT AND DOES NOT RE-IGNITE EVEN IF ROOM TEMPERATURE REQUIRES IT.

- A) Check the performance of the room thermostat and its electrical connections.
- B) Check the position of the room thermostat (check that it is not influenced by external heat sources).

CASE NO. 5: THE EXHAUST FAN WILL NOT START.

- A) Check that the room thermostat is set on the desired temperature.
- B) Check the electrical connections of the exhaust fan and its capacitor.
- C) Check integrity of the unit's protection fuse.
- D) Make sure that neither the limit nor the safety thermostat have operated.

CASE NO. 6: THE EXHAUST FAN STARTS BUT THE UNIT DOES NOT IGNITE.

- A) Intake and/or exhaust duct are obstructed or too long.
- B) The electrical or pneumatic connections of the pressure switch are faulty
- C) The flame control unit does not start the cycle: replace the internal fuse of the flame control unit or the control unit itself.
- D) Pressure switch out of setting: replace or adjust it.

TROUBLESHOOTING FLOWCHART FOR UNIT HEATERS

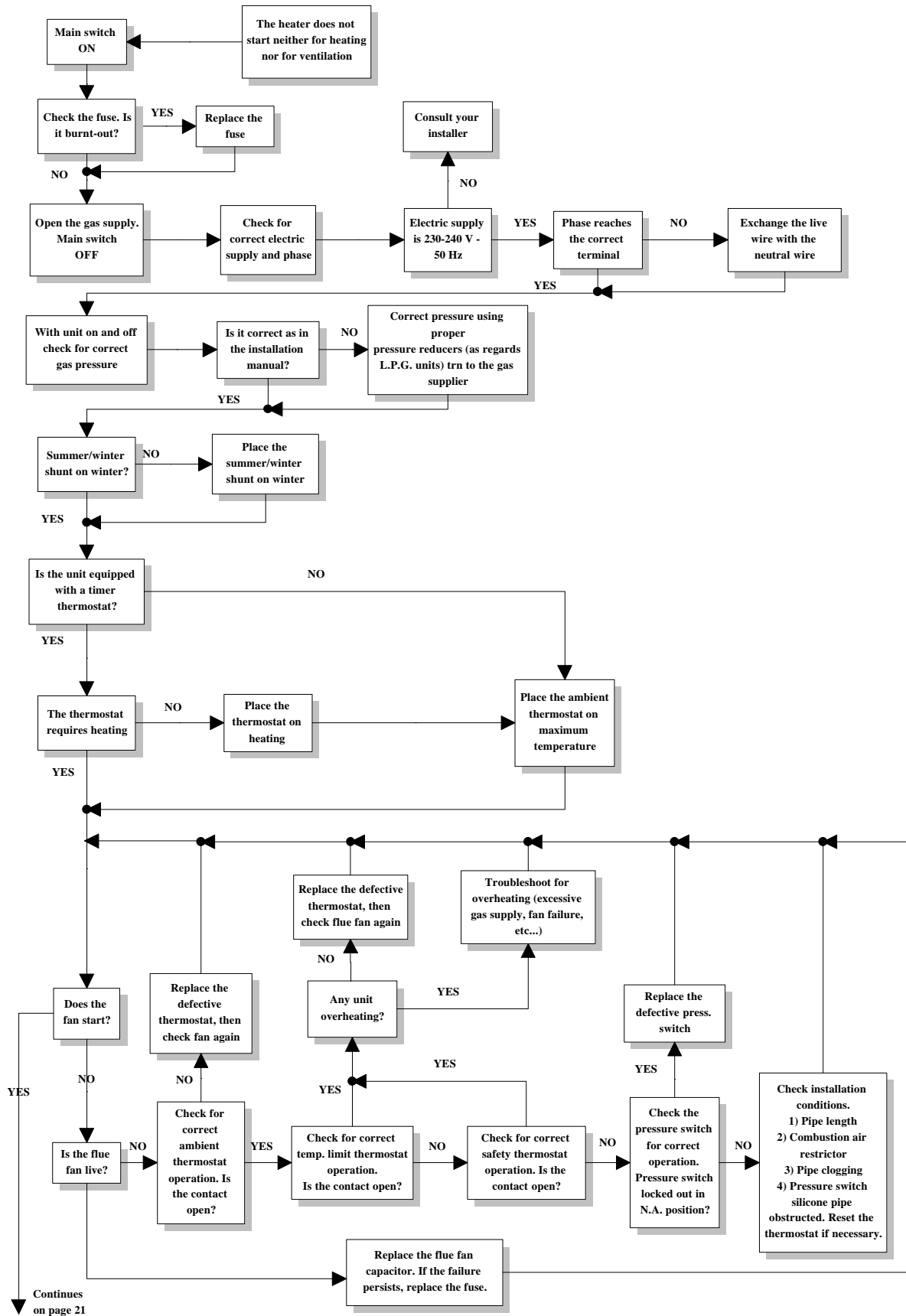

TROUBLESHOOTING FLOWCHART FOR UNIT HEATERS

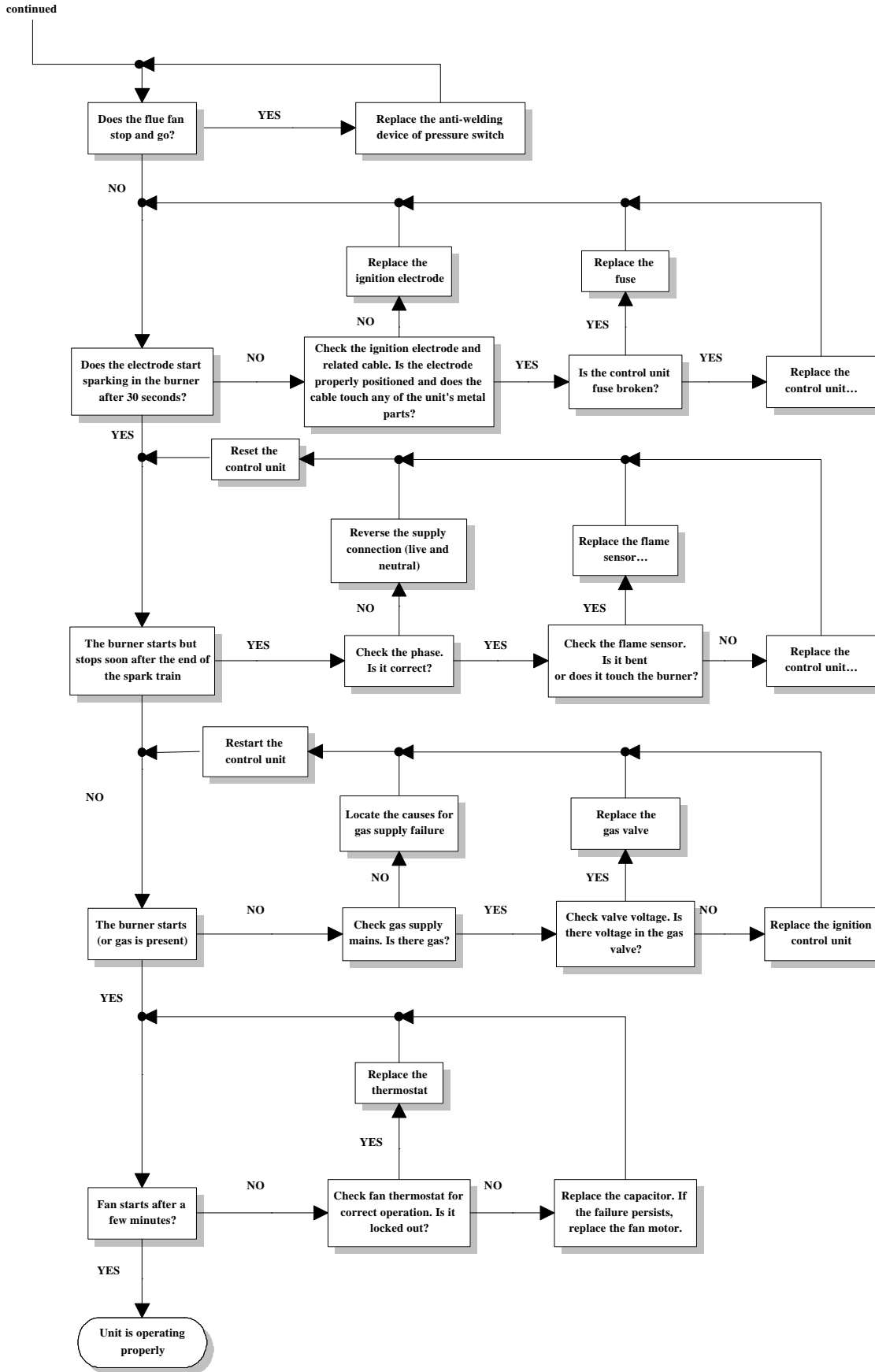

MAIN BURNER

The main burner is made up of a zinc-plated nozzle holder manifold and stainless steel tubular elements.

The tubular elements are equipped with special Venturi tubes for air/gas mixture and special internal baffles to improve mixture distribution.

The burner can be adapted to natural gas or L.P.G. by simply replacing the nozzles and adjusting the burner pressure.

A pressure tap for measuring the gas pressure at the burner is installed on the manifold (P1).

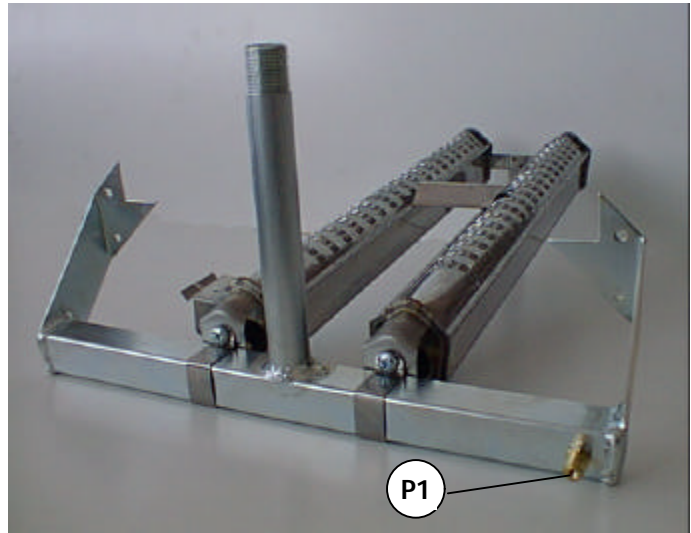

■ Figure 13

	20	25	30	35	40	50	60
Natural gas nozzles (G20) (mm)	2.80	3.30	4.00	4.50	3.30	3.45	4.00
LPG nozzles (G30 - G31) (mm)	1.6/1.8	2.00	2.20	2.40	1.7/1.95	1.85/2.15	2.2/2.3

■ Table 11

IGNITION AND SENSOR ASSEMBLY

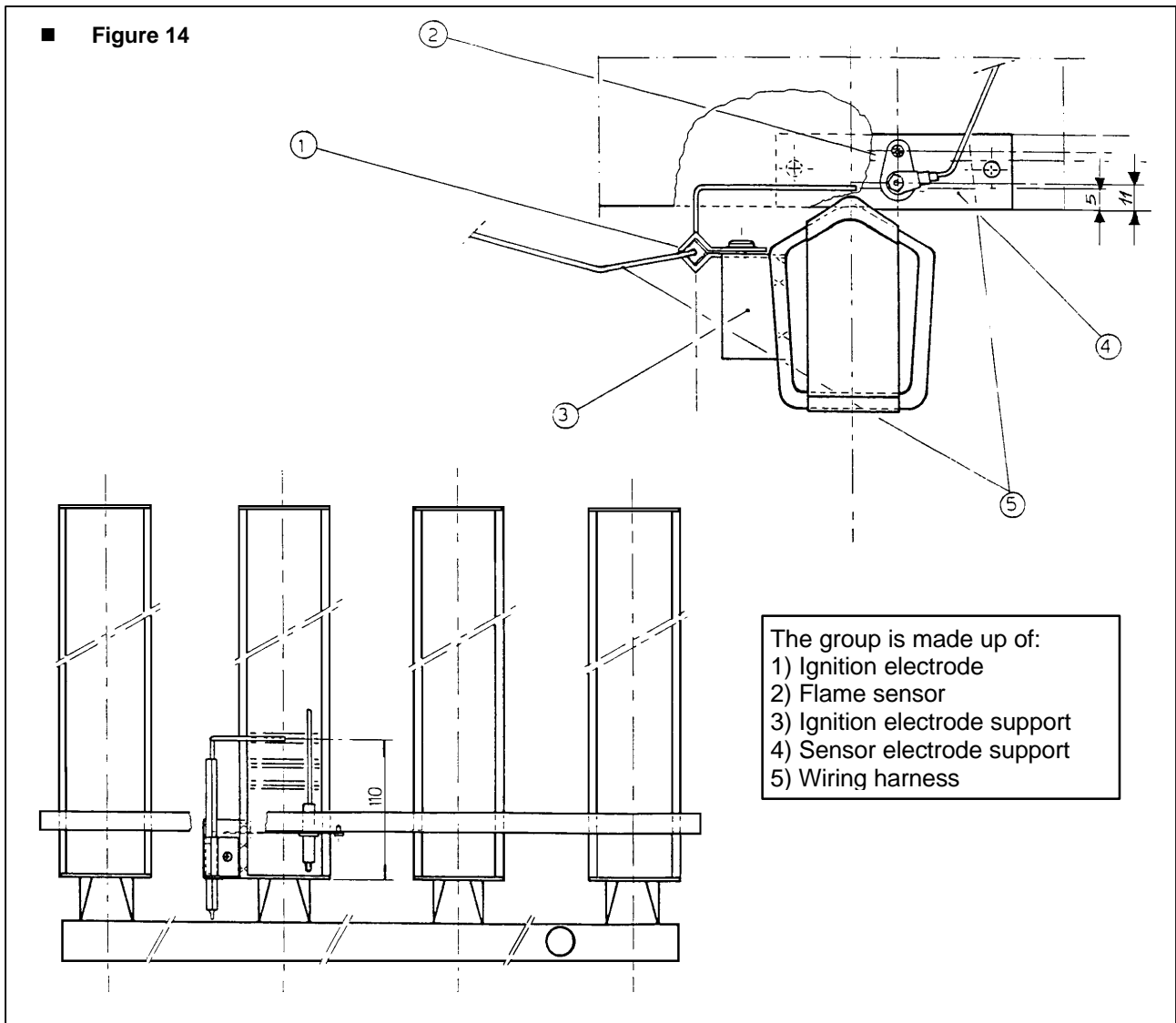

GAS VALVES

SIT 830 Tandem valve (model 20-25-30-35-40)

Specifications:

- Voltage supply: 230-240 V - 50 Hz
- Operating temperature: 0°C up to +60°C

- | | |
|----------------------------|----------------------------------|
| a) Pressure governor | d) Electricity supply connectors |
| b) Inlet pressure tap | e) Outlet pressure tap |
| c) Slow opening adjustment | |

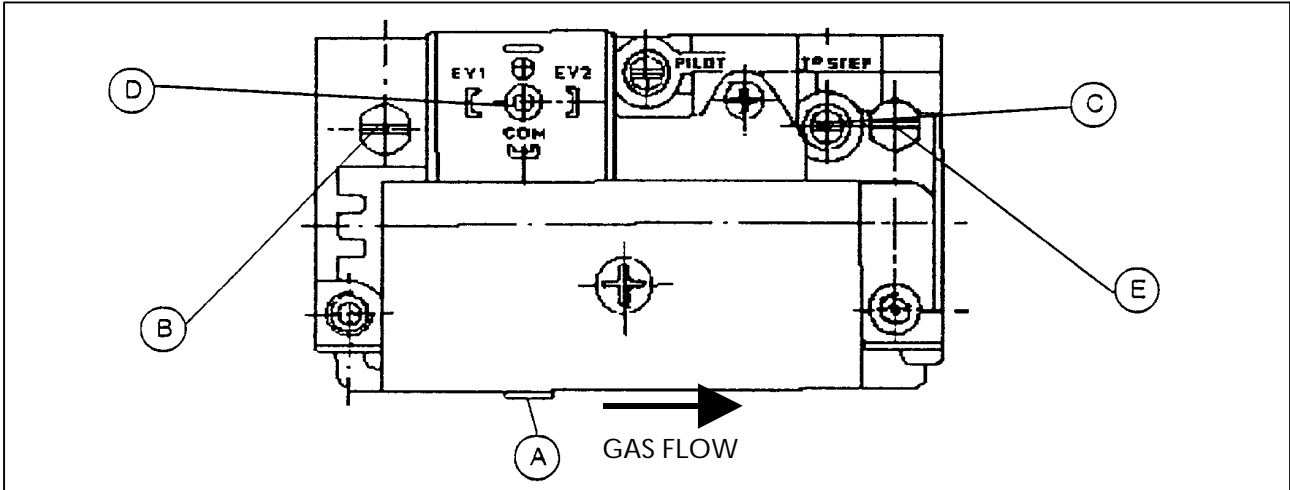

■ Figure 15
SIT 830 TANDEM VALVE

SIT 826 valve (models 50-60)

Specifications:

- Voltage supply: 230-240V - 50 Hz
- Operating temperature: 0°C up to +60°C

- | | |
|---|-------------------------------|
| a) Soft opening setting screw | e) Inlet gas pressure tap |
| b) Burner gas pressure setting screw | f) Outlet gas pressure tap |
| c) Setting screw cap | g) Electric supply connectors |
| d) Connector for electrical supply of the soft opening SMD coil | |

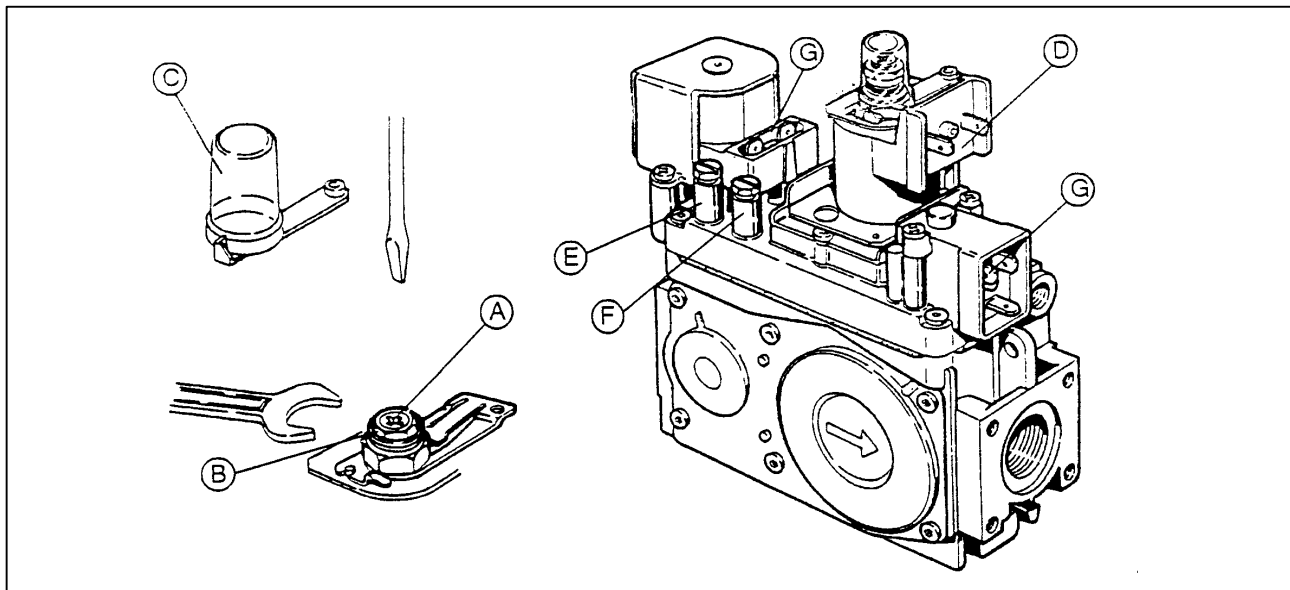

■ Figure 16
SIT 826 VALVE

FLAME CONTROL UNIT

An electronic control unit manages the flame ignition and monitors the presence of flame.

Specifications:

Safety time : 10 sec.
Pre-purge time : 30 sec.
Voltage supply : 230-240V - 50 Hz

CONTROL BOARD

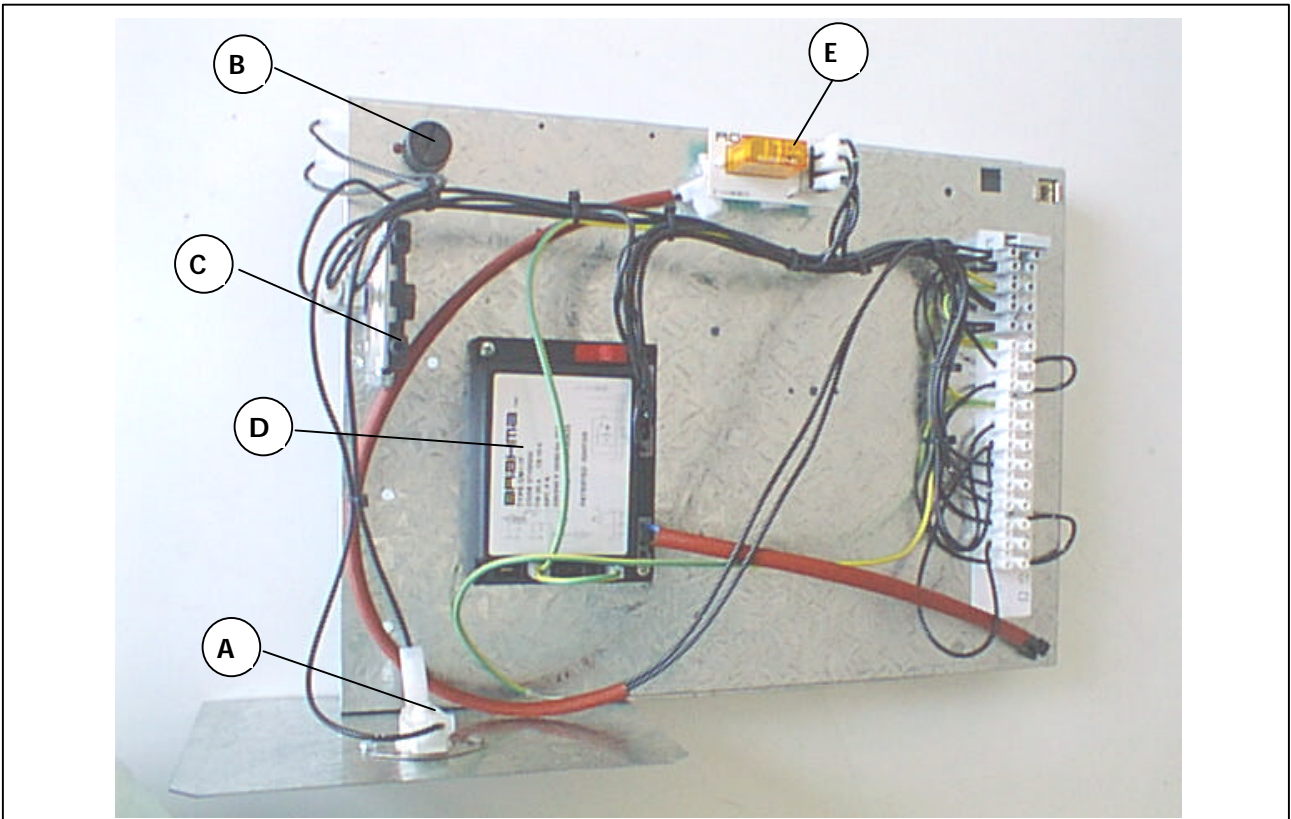

■ Figure 17

- A) Safety thermostat
- B) Temperature limit thermostat
- C) Air pressure switch
- D) Flame control unit
- E) Pressure switch control relay

OPERATING WIRING DIAGRAM

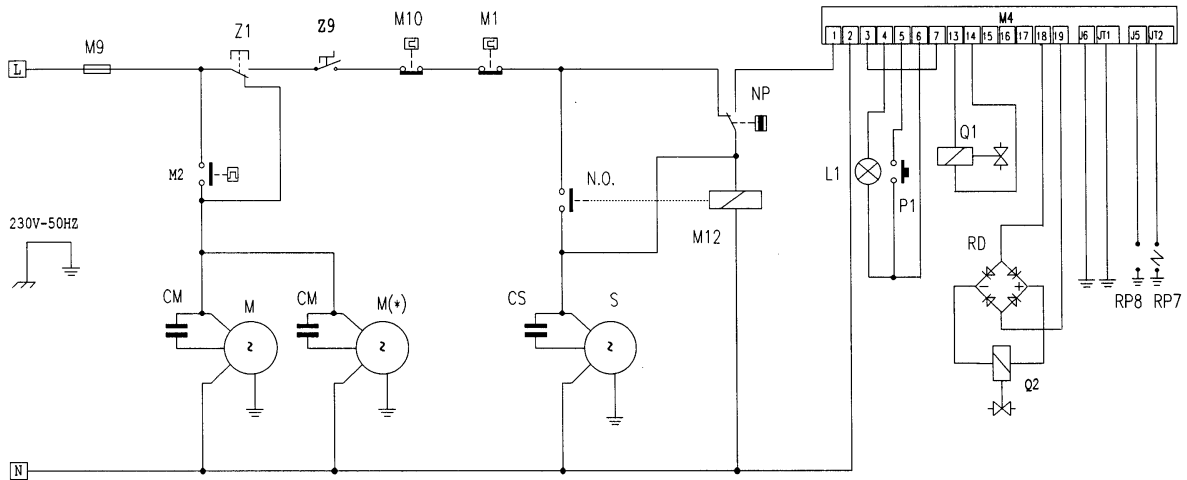

CM	air fan capacitor	M9	fuse 4A
CS	exhaust fan capacitor	P1	reset button
L1	lockout warning lamp	Q1	gas electrovalve
M	fan motor	Q2	soft opening coil
M1	temperature limit thermostat	RD	rectifier bridge (Models 50/60 only)
M10	safety thermostat	RP7	ignition electrode
M12	pressure switch control relay	RP8	flame sensor
M2	fan thermostat	S	exhaust fan motor
M(*)	second air fan motor (Models 50/60 only)	Z1	summer/winter switch (not supplied)
M4	flame control unit	Z9	room thermostat (not supplied)

■ Figure 18

INSTALLATION WIRING DIAGRAMS

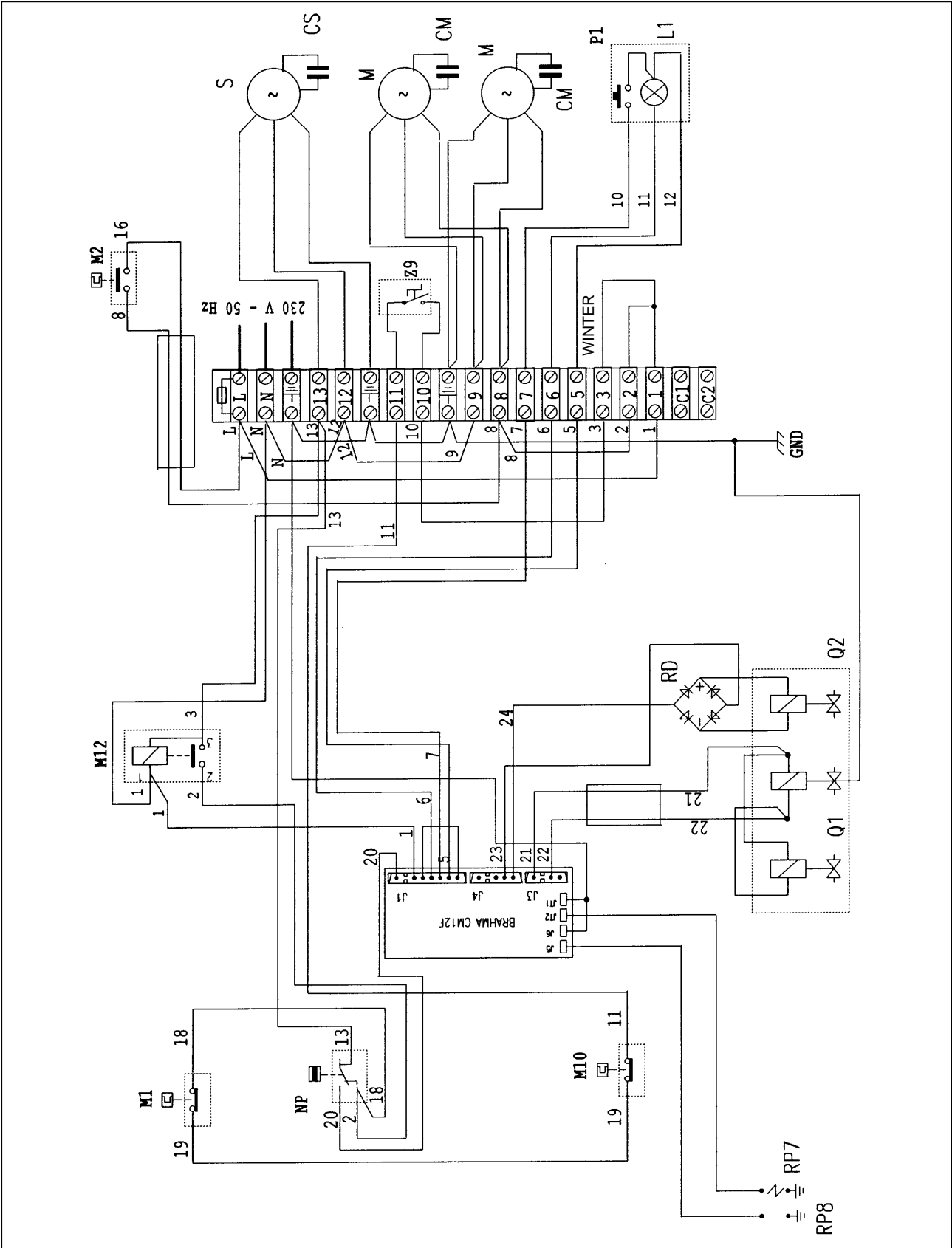

■ Figure 19

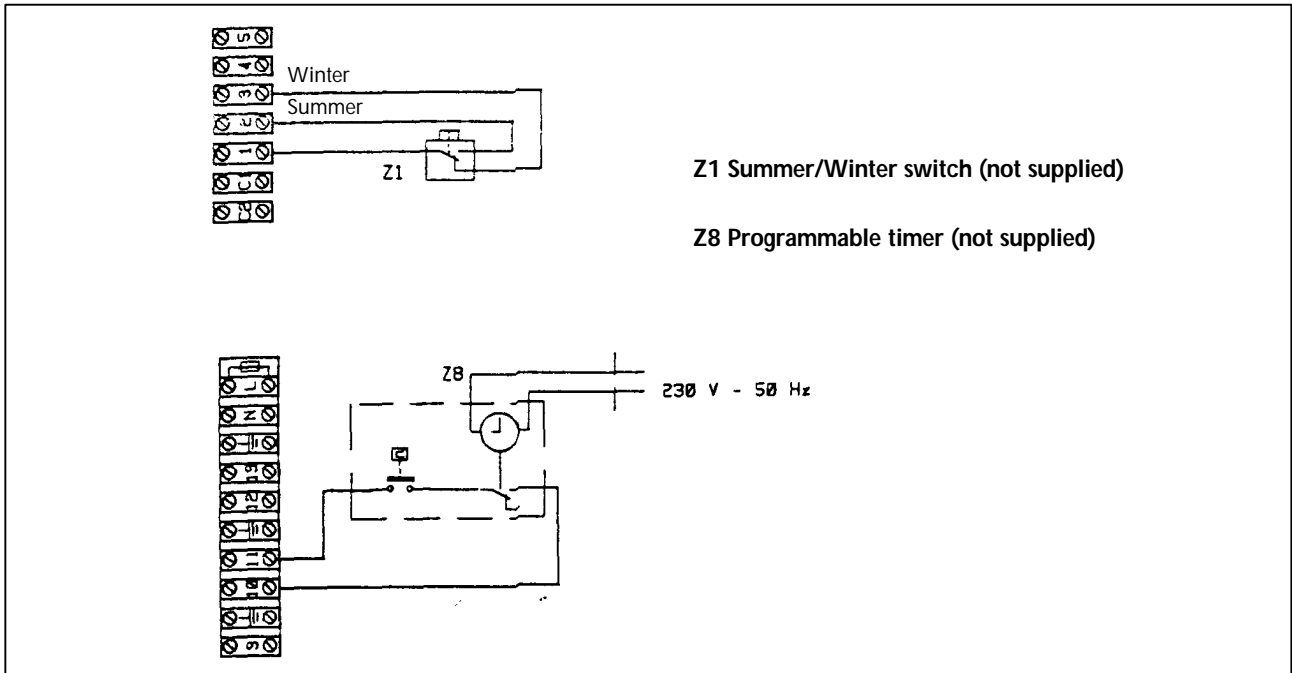

■ **Figure 20**
CONNECTION: SUMMER/WINTER SWITCH (NOT SUPPLIED) AND PROGRAMMABLE TIMER (OPTIONAL)

WIRING DIAGRAMS FOR MULTIPLE HEATERS

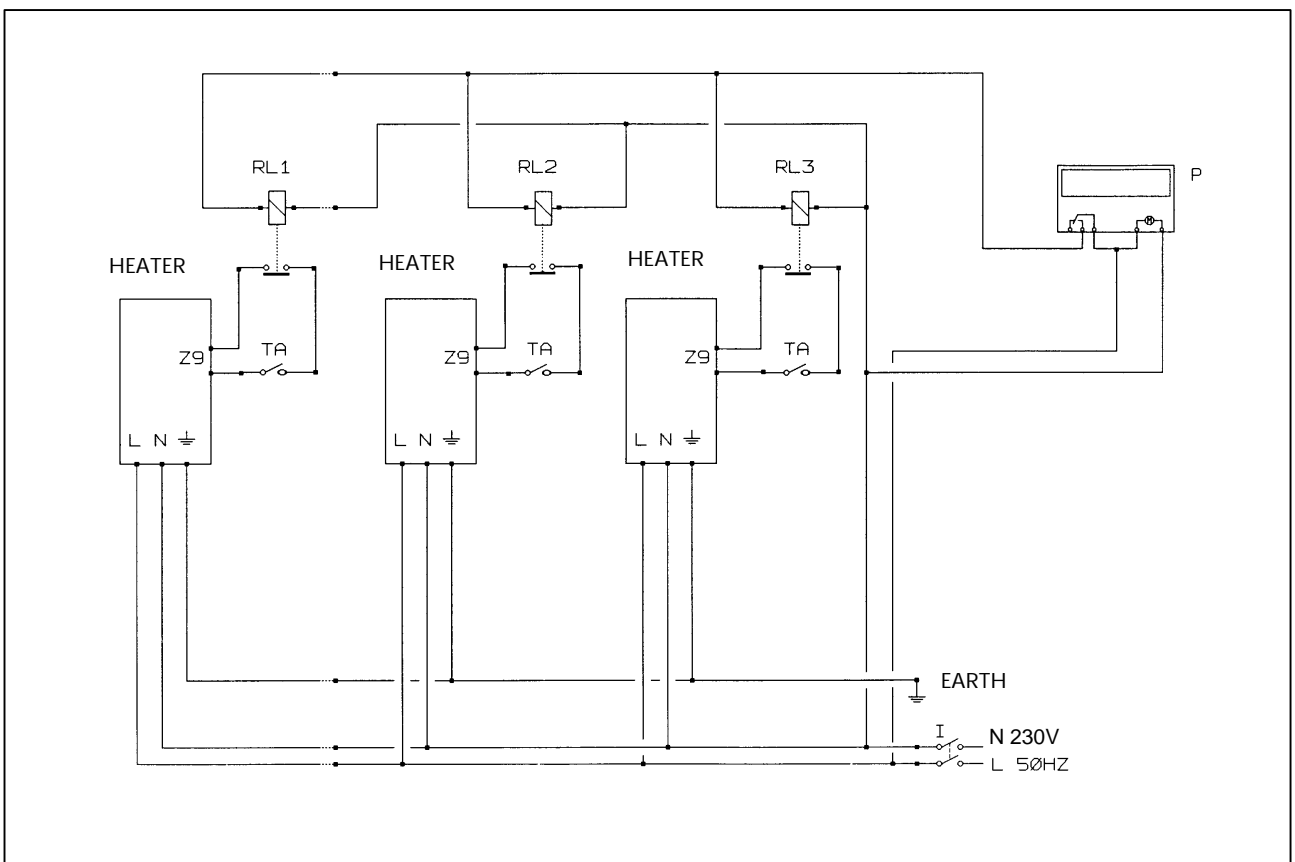

■ **Figure 21**
MULTIPLE HEATER INSTALLATION WITH ONE TIMER AND MORE ROOM THERMOSTATS

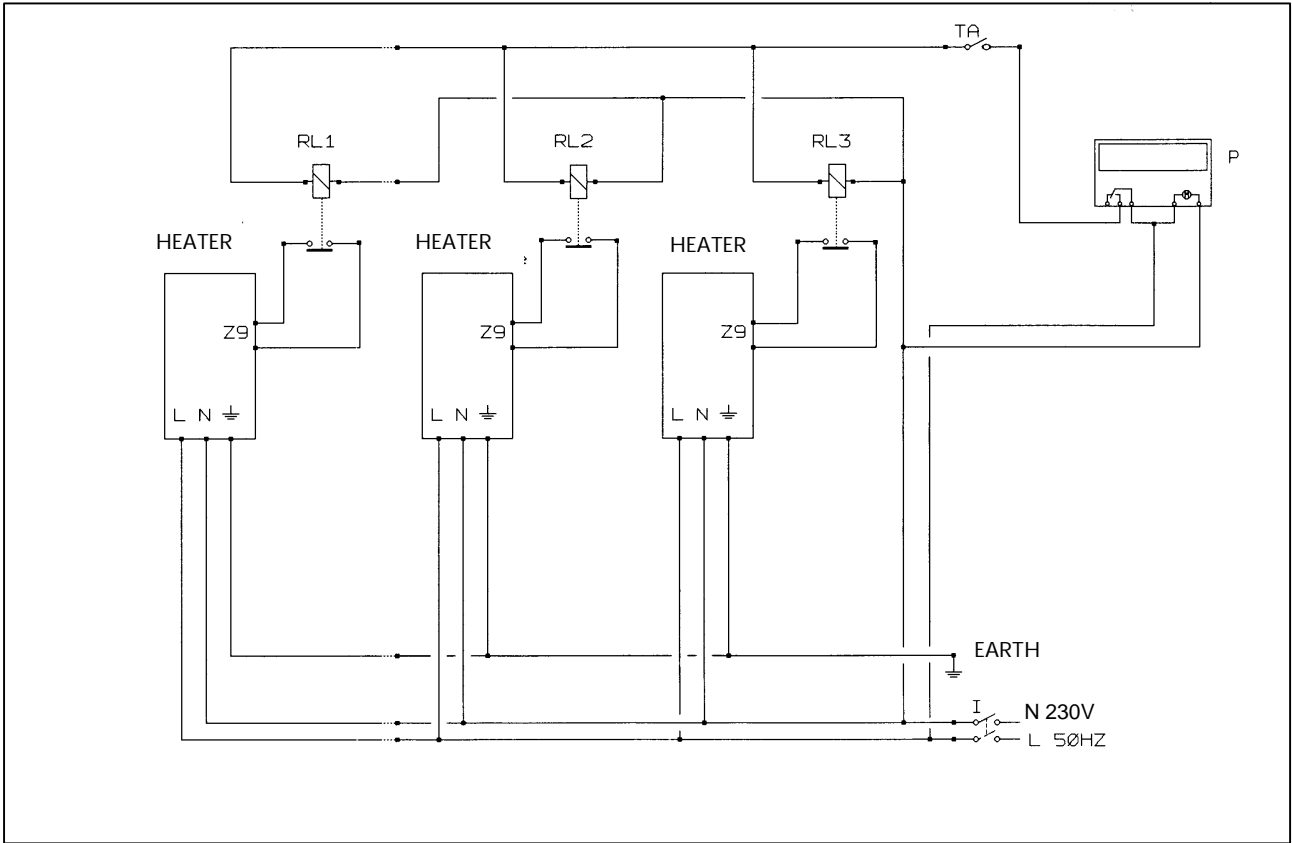

■ **Figure 22**
 MULTIPLE HEATER INSTALLATION WITH ONE TIMER AND ONE ROOM THERMOSTAT (MULTIPLE RELAY INSTALLATION)

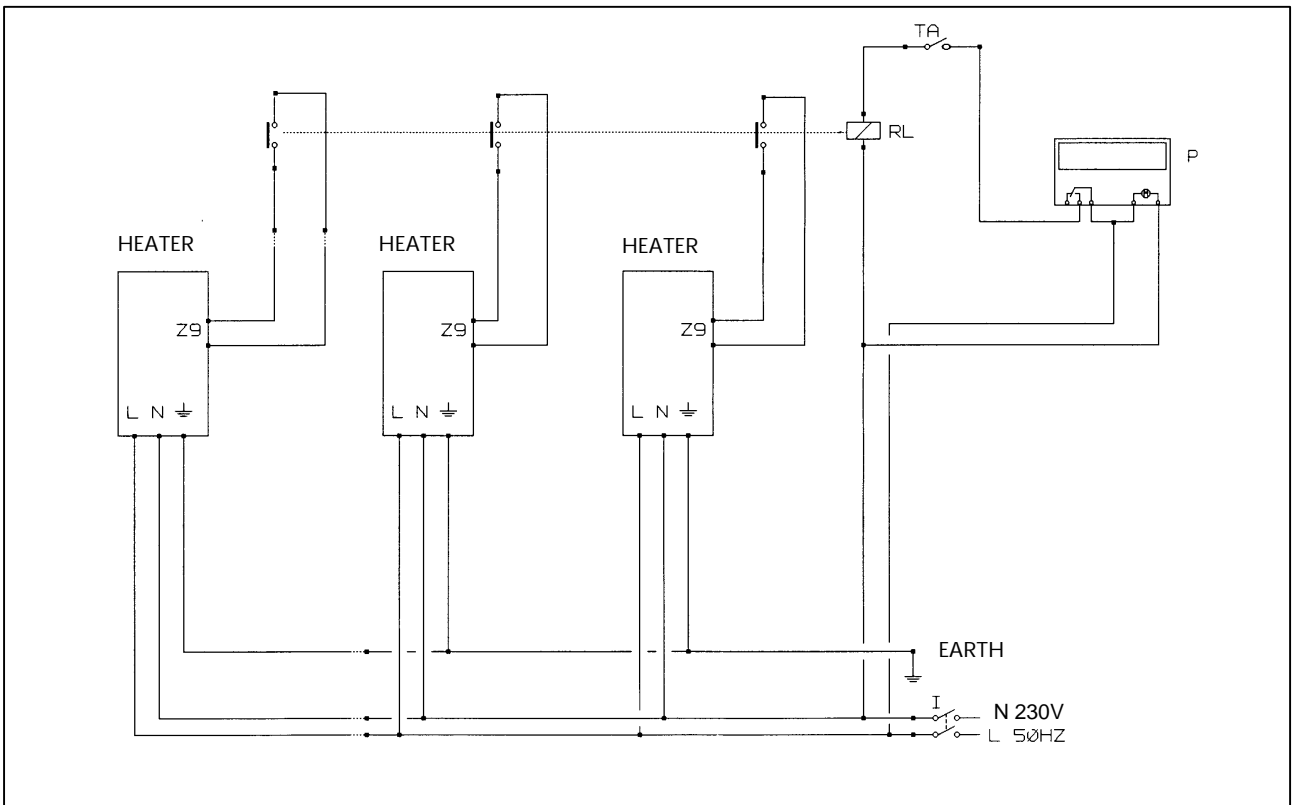

■ **Figure 23**
 MULTIPLE HEATER INSTALLATION WITH ONE TIMER AND ONE ROOM THERMOSTAT (SINGLE RELAY INSTALLATION)

Aiming to improve the quality of its products, Robur S.p.A. reserves the right to change the above instructions and drawings without prior notice.

Robur S.p.A.
Via Parigi 4/6
24040 Verdellino /Zingonia (BG) Italy
Tel. +39-035-888.111 - Fax +39-035-884.165