

Atmos Multi

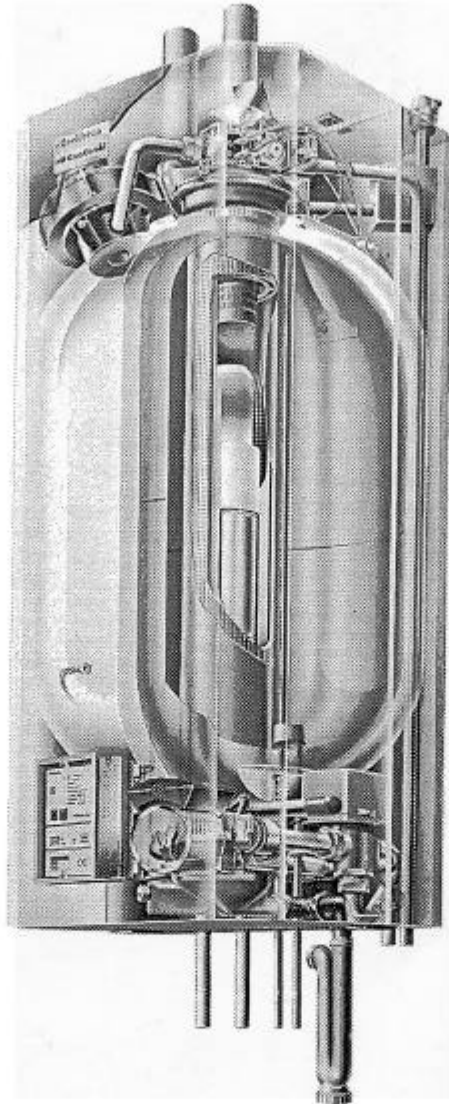

Installation & Servicing Instructions



Table of Contents

Section	Page	Section	Page
Introduction	1	8. Commissioning	25
1. Installation Regulation	2	▪ Filling the heating system	25
2. General Information	2	▪ Filling the domestic hot water	26
3. Technical Data	3	▪ Appliance operation	26
4. Schematic of Boiler	4	▪ System balancing	27
5. Operation and	6	9. System Shutdown	28
□ Appliance construction	6	▪ Central heating circuit	28
□ Operating principle	7	▪ Domestic hot water	28
□ Controls and function	8	▪ Draining the boiler	28
□ User's programme	9	▪ Disposal of appliance	28
6. Installation Requirements	9	10. Inspection & Servicing	28
▪ Gas supply	9	▪ Boiler pre-service inspection	29
▪ Electrical supply	9	▪ Auxiliary equipment	30
▪ Terminal location	10	▪ Servicing the boiler	30
▪ Flue system	10	▪ Completion	32
▪ Condensate disposal	11	11. Component Replacement	33
▪ Discharge pipes	12	12. Malfunctions	37
▪ Existing systems	14		
7. Boiler Installation	14	Appendices.	
▪ Unpacking the boiler	14	1. Spare part list	
▪ Minimum clearances	15	2. Combined safety & condensate discharge	
▪ Boiler location	15	3. Fault finding	
▪ Wall mounting the boiler	16	4. Guarantee stipulations	
▪ Connecting the flue system	17		
▪ Connecting the c/heating	18		
▪ Connecting the mains water	19		
▪ Connecting the discharge pipes	20		
▪ Connecting the domestic hot	21		
▪ Connecting the gas supply	21		
▪ Connecting the condensate	22		
▪ Connecting the electrical supply	22		

Introduction

The Atmos Multi gas fired storage combination boiler that meets the requirements of Statutory Instrument 'The Boiler (Efficiency) Regulations' and is deemed to meet the requirements of:

- ❑ Gas Appliance Directive 90/396 EEC
- ❑ Efficiency Directive 92/42/ EEC
- ❑ Low Tension Directive 73/23 EEC (modified from 93/68) and;
- ❑ Electromagnetic Compatibility Directive 89/396 EEC (modified from 93/68)

Atmos Heating Systems declare that the materials used in the manufacturer of this appliance are non-hazardous and that no substances harmful to health are contained within the appliance.

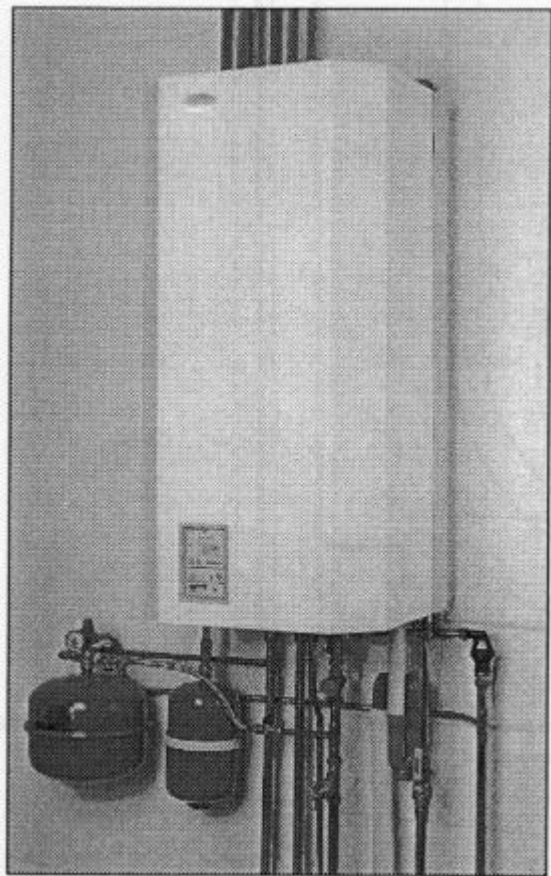

The Atmos Multi must be installed in accordance with these instructions and the regulations currently in force. Please read these instructions fully before installation and leave with the boiler for future reference.

Atmos Heating Systems accepts no responsibility for unsatisfactory performance of the appliance or flue arising from the failure to comply with these installation instructions.

On completion of installation the appliance must be commissioned and the following explained to the user:

- ❑ The operating principle of the appliance
- ❑ The appliance controls and display
- ❑ Starting up, filling and de-aerating the appliance
- ❑ Shutting down and draining
- ❑ Annual inspection and maintenance

Atmos Heating Systems have a policy of continuing improvement in the design and performance of its products. The right is therefore reserved to vary specifications without notice.

For advice or information contact Atmos Heating Systems by telephone or e-mail.

Atmos Heating Systems is part of the Benchmark scheme. All our boilers include the Benchmark Logbook and we advise all our installations to be carried out to Benchmark standards.

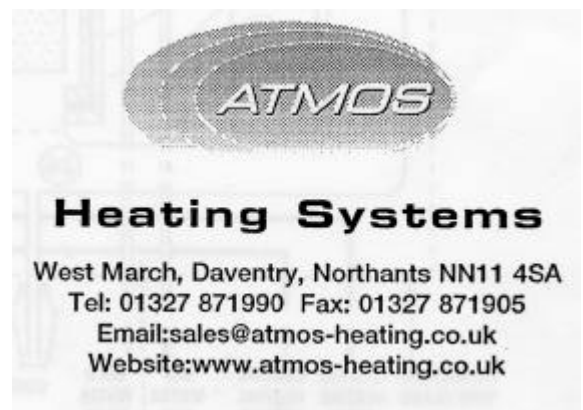

1. Installation Regulations.

1.1 A qualified registered installer in accordance with the Gas Safety (Installation and Use) Regulations; October 1994 must only install this appliance. Failure to install appliances correctly could lead to prosecution.

1.2. The manufacturer instructions must not be taken as overriding statutory requirements.

1.3 The installation of this appliance must be in accordance with the relevant requirements of the Gas Safety (Installation and Use) Regulations 1984 as amended, Building Regulations, Building Standards (Scotland), IEE Wiring Regulations (BS 7671), Health and Safety Document No.635 (Electricity at Work Regulations) and local Water Authority bye laws.

1.4 Installation should also be in accordance with the relevant recommendations contained within the current versions of the following British Standards.

- ❑ BS 6798 Specification for installation of gas fired hot water boilers of rated input not exceeding 60 kW.
- ❑ BS 5449 Central Heating for Domestic Premises.
- ❑ BS 5546 Installation of gas hot water supplies for domestic purposes.
- ❑ BS 5440 Flues and Ventilation for gas appliances of rated input not exceeding 60 kW. (Part 1 Flues).
- ❑ BS 5440 Flues and Ventilation for gas appliances of rated input not exceeding 60kw (Part 2 Air Supply).
- ❑ BS 6891 Installation of low pressure gas pipework installations up to 28mm (R1).

Reference should also be made to British Gas Guidance Notes for the Installation of Domestic Gas Boilers.

1.5. To ensure that the installation will perform to the highest standards, the system and components should conform to any other relevant British Standards in addition to those mentioned in these instructions.

1.6. For Installation in Ireland the appliance must be installed in compliance with I.S.813 'Installation of gas appliances'.

1.7. Asbestos and CFC's are not used in the manufacture of these products.

2. General Information.

2.1 The Atmos Multi is a wall mounted, fully automatic gas fired condensing combination boiler designed to provide 'unvented' domestic hot water at mains pressure via an integral hot water storage cylinder.

2.2 Classified as an 'Unvented hot water system' the installation of the Atmos Multi falls within the scope of the Building Regulations 1995 (Part G.). These require that a competent person as defined in the Approved Document G3 must only undertake the installation of an unvented system.

2.3 For central heating applications the Atmos Multi is suitable only for use on a fully pumped, pressurised, sealed primary system with a design (cold) pressure of between 0.5 and 2.5 bar.

2.4 The boiler may be installed in any room or internal space without the need for purpose made ventilation, although attention is drawn to the current IEE Wiring Regulations with respect to installation in a room containing a bath or shower. In such installations, it must not be possible for a person using the bath or shower to touch any mains electricity fed switch or boiler control.

2.5 In areas where the temporary hardness of the supplied water exceeds 200mg/litre, a proprietary in-line scale control device such as the 'Hydroflow' (available from Atmos Heating Systems) should be fitted in the cold feed to the boiler.

2.6 Although fitted with an automatic air release valve it should be ensured that the boiler's heat exchanger is not a natural collecting point for air. Air vents must be fitted at the highest positions of the heating flow and return pipes and at any other point in the system where air is likely to collect.

2.7 The Atmos Multi is suitable to accept pre-heated water such as that supplied from solar panel installations.

2.8 To ensure economic use of domestic hot water, it is recommended that pipe runs between the boiler and taps be in 15mm copper, as short as possible and, where practical, be insulated to reduce heat loss.

2.9 Where the boiler is intended for use on **Propane gas** the boiler must not be installed in a room or internal space below ground level.

3. Technical Data

	Natural Gas & Propane		Natural Gas	Propane
	24/80	24 / 80 Plus	32 / 80 Plus	32 / 80 Plus
CONDENSING MODE (Return < 55°C)				
Heat Output to radiators kW min - max	7.3 - 22.5	7.3 - 22.5	9.8 - 29	9.8 - 29.9
Maximum heat to radiators Btu/hr	76.800	76.800	99.000	102.000
Gross efficiency max - min	98 - 91%	98 - 91%	98 - 91 %	98 - 91%
NON-CONDENSING MODE (80/60°C flow/return)				
Heat Output to radiators kW min - max	6.9 - 21.5	6.9 - 21.5	9.3 - 27.6	9.3 - 28.5
Maximum heat to radiators Btu/hr	73.400	73.400	94.200	97.300
Gross efficiency max - min	93 - 87%	93 - 87%	93 - 86%	93 - 86%
Seasonal efficiency (Sedbuk certified) %	91.3	91.3	91	91
Gas flow rate m ³ /hr natural gas min/max	0.8 - 2.6	0.8 - 3.3	1.1 - 3.5	0.4 - 1.25
Flue gas temperature min/max°C	35/100°C	35/100°C	40/110°C	40/110°C
HOT WATER SYSTEM				
Maximum heat to hot water kW	17.4	26.4	27.6	28.5
Hot water flow rate maximum litres/min at 2bar	25	25	25	25
Reheat time from 10 to 60°C minutes	20	12	11	10
70% reheat time minutes	17	10	9	9
Hot water at 40°C instantaneously (litres)	133	133	133	133
Hot water per hour at 40°C (litres)	450	700	725	750
Hot water per hour at 40°C (gallons)	100	150	160	165
EMISSIONS				
NOx (average) emission ppm	18	18	19	19
CO (average) emission ppm	10	10	20	20
GC Number	41-249-02	41-249-03	41-249-04	41-249-04

COMMON DATA

Hot water temperature setting range	60 to 70°C
Central heating setting range	60 to 90°C
Hot water tank capacity	80 litres
Primary water capacity	2.2 litres
Hot water expansion vessel capacity	5 litres
C/ heating expansion vessel capacity	8 to 18 litres
Maximum supply pressure	12 bar
Electrical Connection	220/240V
Outlet pressure hot and cold water	3.5 bar
CONNECTIONS	
Air supply pipe diameter	80 mm
Flue pipe diameter	80 mm
Heating flow and return	22 mm
Hot water outlet	15 mm
Cold water supply	22 mm
Gas pipe connection	½" BSPM
Safety Valve discharge connection	22 mm
Condensate discharge drain connection	32 mm
Underfloor heating flow connection	½" BSPF
DIMENSIONS AND WEIGHT	
Height	1080 mm
Width	525 mm
Depth	495 mm
Minimum distance above floor	600 mm
Weight empty	70 kg
Weight full	150 kg

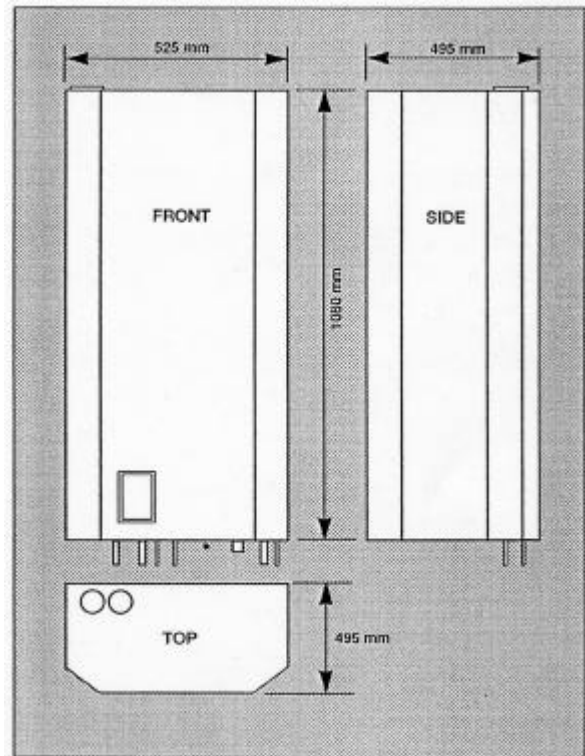

4. Schematic of Atmos Multi Boiler

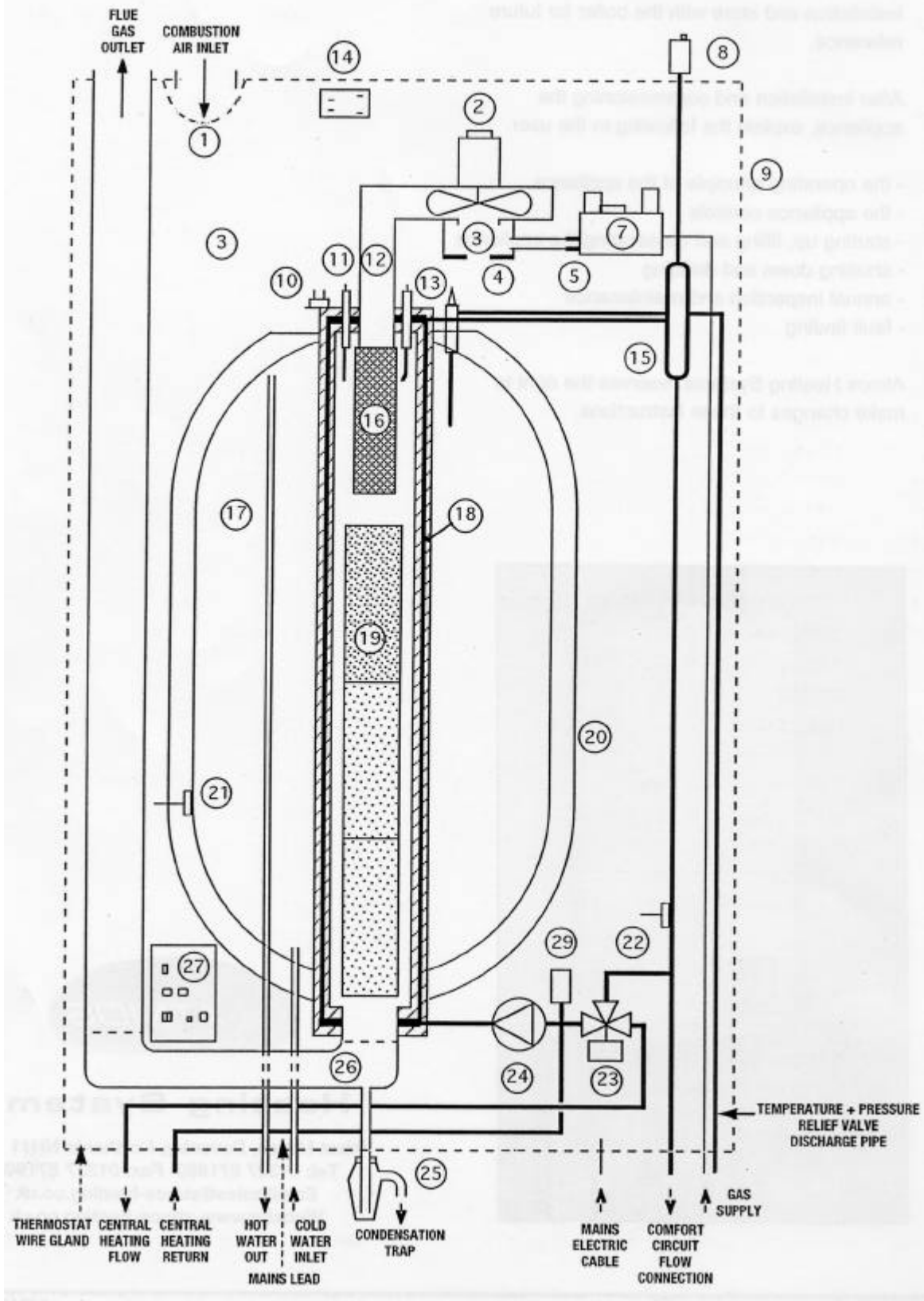

Key

		Type
1	AIR INLET FILTER	ATMOS
2	FAN	ALCATEL/SEL RG 148/1200-3612, 325 VDC
3	GAS/AIR MIXING CHAMBER	ATMOS
4	CATCHMENT PLATE	ATMOS
5	GAS INJECTION NOZZLE	ATMOS
7	GAS VALVE	HONEYWELL VR 4605 VA1009 220/240 VAC
8	AUTOMATIC AIR VENT	TACO 3/8"
9	CASING	ATMOS
10	HIGH LIMIT THERMOSTAT	THERM-O-DISC 36TX E31 L 105°C
11	IONISATION PROBE	ATMOS
12	INLET CASTING	ATMOS
13	IGNITION ELECTRODE	ATMOS
14	IGNITION TRANSFORMER	ANSTOSS ZIG 2S
15	AIR SEPARATOR	ATMOS
16	BURNER	FURIGAS PREMIX
17	HOT WATER TANK	ATMOS - 80 LITRE COPPER
18	HEAT EXCHANGER	ATMOS - EXTRUDED ALUMINIUM
19	FLUE GAS RESTRICTOR	ATMOS
20	INSULATION SHELL	ATMOS (CARIL)
21	HOT WATER TEMPERATURE SENSOR	ATMOS
22	HEATING WATER TEMPERATURE SENSOR	ATMOS
23	THREE-WAY VALVE	ERIE TYPE 679 220/240 VAC
24	CENTRAL HEATING PUMP	ATMOS
25	SIPHON	ATMOS
26	OUTLET CASTING	ATMOS
27	CONTROL UNIT	ATMOS
29	CENTRAL HEATING WATER PRESSURE SENSOR	HUBA CONTROL TYPE: 690.99002
	FLUE GAS OUTLET CONNECTION	Ø 80 MM
	AIR SUPPLY CONNECTION	Ø 80 MM
	CENTRAL HEATING SUPPLY PIPE	Ø 22 MM
	CENTRAL HEATING RETURN PIPE	Ø 22 MM
	HOT WATER PIPE	Ø 15 MM
	COLD WATER PIPE	Ø 15 MM
	CONDENSATION DISCHARGE	Ø 32 MM
	COMFORT CIRCUIT HEATING CONNECTION	1/2" BSPF
	GAS CONNECTION	1/2" BSPM
	ROOM THERMOSTAT CONNECTION	24 VAC / 0.12 A
	MAINS LEAD	220 / 230 V

5. Operation and construction

The Atmos Multi is a fully automatic, gas fired, high efficiency central heating boiler providing unvented domestic hot water at mains pressure via an integral 80 litre copper hot water storage tank.

5.1 Construction of the appliance

A heat exchanger consisting of three concentric channels is positioned in the centre of the boiler's integral hot water tank. (Fig.1).

- ❑ Hot flue gas released from a fully modulating, pre-mix burner positioned at the top of the heat exchanger, is driven downwards through the heat exchanger's middle channel.
- ❑ The second surrounding channel is divided into eight smaller central heating water channels, which together promote the transfer of heat from the heat exchanger to water within the boiler's primary circuit.
- ❑ The third surrounding channel is divided into small air channels. These together with the inner copper wall of the hot water tank forms a double partition between the central heating and stored hot water.

While the hot water tank is completely insulated by means of insulation shell sections, the hot water tank itself along with the boiler's other components is housed behind a removable outer steel appliance casing, constructed in such a manner to ensure the enclosed appliance space is ventilated.

Operation of the Atmos Multi boiler is controlled and monitored by an electronic control unit that sends and processes information to and from the boiler's various temperature and control components. Along with controlling the boiler's operation the control unit also provides a diagnostic programme that simplifies fault finding by automatically sending a fault code to a 'Status/error code display' window located on the control unit's fascia.

Central heating & Hot water circuit

When there is a demand for domestic hot water or central heating, the water within the boiler primary circuit is pumped through the heat exchanger from the

bottom to top via the central heating water channels to a three way valve.

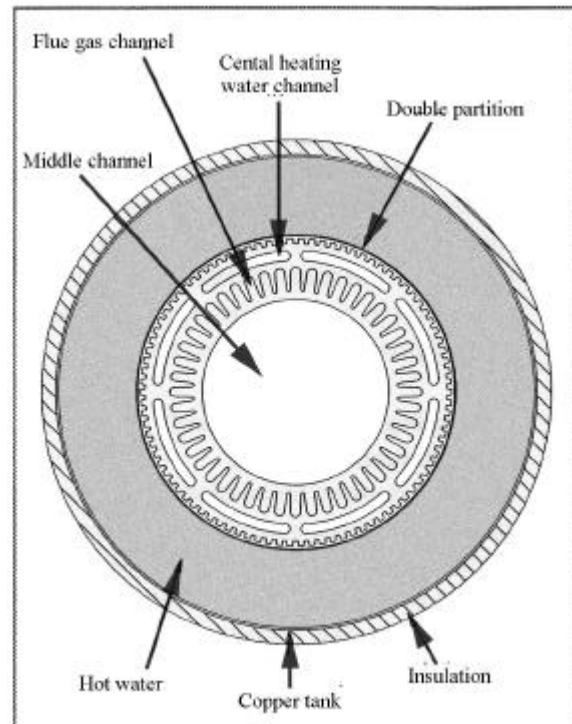

Figure 1 : Appliance Cross-Section

If there is a demand for hot water only, water within the primary circuit circulates through the heat exchanger only.

If there is a demand for central heating only, the three-way valve changes position allowing the heated primary water to flow from the heat exchanger to the central heating system.

Where there is a demand for both domestic hot water and central heating the three-way valve stays in a mid-position, supplying heated water to both systems.

Flue gas circuit

The burners combustion air fan drives hot flue gases produced by the combustion process from the top to the bottom of the heat exchanger. Cooling of the flue gases occur as they flow through the flue gas channels towards their point of exit. On cooling the water vapour suspended within the flue gas condenses, transferring its latent heat as sensible heat to the cooler water within the heat exchanger. The resultant condensate

then falls to the bottom of the heat exchanger where it is automatically discharged via the boiler's condense drain point.

5.2 Operating principle of the appliance

❑ No heat demand

The appliance will carry out a self-test every 24 hours when the connected to an available electrical supply. For this test the boiler's integral central heating pump will run for 3 minutes and the three-way valve will switch to central heating in order to prevent the pump from seizing.

❑ Meeting the heat demand (continuous comfort mode)

If there is demand for heating and domestic hot water at the same time, the hot water demand has priority over the heating demand. This is achieved by constant regulation of the three-way valve from the control unit. The 'continuous comfort' mode may be switched off if not required.

The central heating is controlled using a standard 24V room thermostat or modulating room thermostat. The domestic hot water temperature is controlled by a 'user' setting, which is adjusted via the control unit.

❑ Heat supply

When there is a demand for central heating, the boiler's integral central heating pump and combustion fan are automatically switched on. Burner ignition occurs on the combustion fan reaching its regulated speed. If no flame signal is detected after 5 seconds, three more attempts for burner ignition will be made within a 15-second period, after which the appliance will shut down.

On a loss of flame the appliance will carry out four restart attempts, after which the appliance will shut down. If the temperature of the central heating water reaches 90°C, the burner will automatically be extinguished. The appliance has an anti-cycling time of 3 minutes during which the burner will not re-ignite. The anti-cycling period may be changed via the control panel to 6 minutes or alternatively, switched off.

On reaching the heating demand the burner will shut down and the central heating pump continues to run for a further one-minute period after which, the three-way valve will switch to domestic hot water heating. The pump will then run in hot water heating mode for 20 minutes (Factory setting). The pump running times may be adjusted to suit individual system requirements (see separately available Atoms Multi Service Manual).

An insufficient heating water flow rate will be detected by the high limit thermostat, which on activation will cause the appliance to shut down.

❑ Combustion

The appliance is equipped with a continuously modulating burner. The burner's heat input may be manually set to suit individual system requirements by adjustment of the fan pressure via a mechanical gas-air connection. The appliance heat input automatically reduces as the central heating flow temperature reaches 80°C or higher.

❑ Most Efficient Start

Most Efficient Start is a comfortable energy saver, which ensures that the home is heated as efficiently as possible. When there is a central heating demand the appliance always starts heating the home on a low burner heat input. The amount of time at which the burner continues to operate at low input depends upon the heating demand of the heating system.

After either first connecting the appliance to the power supply, resetting following shut down or following a 180 minute period with no heat demand, the burner will operate on a low heat input for 3 minutes, thereafter it is self adjusting.

5.3 Controls and function.

The function mode of the appliance and the central heating water pressure are indicated on the electronic control unit's front fascia (fig 2), located at the bottom left of the appliance

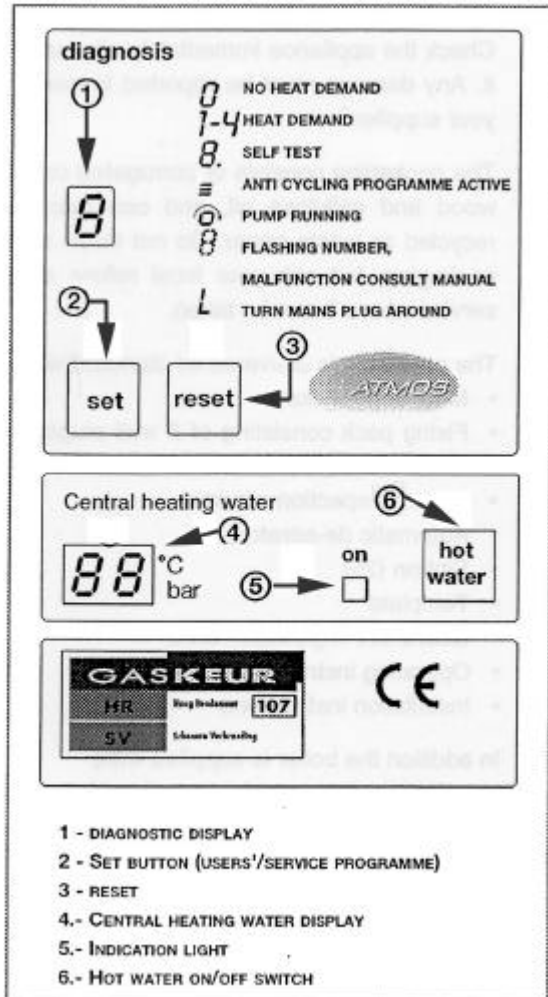

Figure 2 Control unit fascia

□ Diagnostic display (fig 2 (1))

The boiler's operating status is indicated on the diagnostic display. The various status codes are explained in table 1. A flashing display or letter symbol indicates that a boiler malfunction or appliance lockout has occurred. The procedure to follow is given in Section 12 of these instructions.

0	-	STANDBY, NO HEAT DEMAND
1	-	HOT WATER DEMAND
2	-	CENTRAL HEATING DEMAND
3	-	HEAT DEMAND HW AND CH
4	-	HEAT DEMAND HW AND CH, SUPPLY TO BOTH
1 to 4	-	SEE 1-4 WITH BURNER IN OPERATION
5	-	FROST PROTECTION ACTIVE
6	-	PRE AND POST FLUSHING TIME
7	-	IGNITION PHASE
8	-	SELF TEST (8.8. APPEARS ON THE CENTRAL HEATING DISPLAY AND THE BOILER INDICATION LIGHT COMES ON)
≡	-	ANTI-CYCLING SWITCHING ON
≡	-	(ALTERNATED BY NUMBERS 1 - 4)
⊙	-	SECONDARY OPERATION PUMP INTERNAL - HOT WATER
⊙	-	(4 ROTATING SEGMENTS)
⊙	-	SECONDARY OPERATION PUMP EXTERNAL - CH -
⊙	-	(6 ROTATING SEGMENTS).

Table 1: Status reports

□ Central Heating Display (fig 2 (4))

The central heating display may be set to indicate either the central heating water pressure (factory setting) or central heating water temperature. (See 'User's programme' page 9)

If the central heating water pressure is too low or too high, a warning symbol 'C' is shown on the diagnostic display. Further information is given in Section 12 of these instructions

□ Hot water button (fig 2 (6))

If required the heating of domestic hot water may be switched off using the hot water button. Pressing the button once will turn off the indicator light and curtail the hot water demand.

□ Set button (fig 2 (2))

The set button is used to initiate an integral programme to allow changes to be made to the boiler's factory settings and other installation and service activities. To protect against accidental use the set button has to be depressed for a period of 5 seconds before activation occurs. Further information on this subject can be found in the separately available Atmos Multi Service Manual.

❑ **Reset button.** (fig 2 (3))

A lockout situation following a malfunction is cancelled using the reset button. The button is also used to exit the 'User's programme'.

5.4 User's programme

Along with giving operation and fault status codes down to component level the electronic control also permits the manual setting of the boilers operational perimeters.

While the factory set parameters are suitable for 90% of installations, in some cases such as the elderly, infirm or very young for example, a lower radiator surface temperature or domestic hot water temperature may be desirable.

The Atmos Multi in-built user's programme allows the user or installer to tailor suit certain operational perimeters such as the domestic hot water temperature, to the end users requirements.

Access to the user's programme is gained by pressing the control unit's 'Set' button for a period of 5 seconds until a letter 'b' appears in the diagnostic display window. Incremental scrolling through the operational perimeters is then obtained by re-pressing the 'Set' button.

The current setting for the selected operational perimeter appears in the central heating water display window. Pressing the 'Hot water' button enables the setting to be changed to the required value.

The user programme is terminated automatically after five minutes from when the last input action was carried out. Alternatively, exit from the programme is achieved by pressing the 'Reset' button.

Operational perimeters accessible via the users' programme are given in Table 2, the factory settings being underlined.

HOT WATER TEMPERATURE CONTROL	1-2-3
MAXIMUM HEATING TEMPERATURE	60-75- <u>90</u> [°C]
STANDARD CH-WATER PRESSURE INDICATION [BARS]	
CONTINUOUS COMFORT:	OFF- <u>ON</u>
MES MAXIMUM LOW COMBUSTION TIME	OFF-5- <u>10</u> -15 [MIN.]
ANTI-CYCLING MECHANISM FOR CENTRAL HEATING	OFF- <u>3</u> -5 [MIN.]

Table 2 : Users' programme settings

Further information on setting operation perimeters is given in the Atmos Multi Service Manual.

6. Installation Requirements.

6.1 Gas supply

The gas meter and supply pipe must be capable of delivering the required quantity of gas to the boiler (refer to Technical Data page 3) in addition to the demand from any other appliances within the property. On final connection of the gas supply to the boiler, the properties complete gas installation, including the meter, must be tested for gas soundness and purged as described in BS6891.

6.2 Electrical supply

The boiler requires a 230/240 V~50 Hz mains supply fused at 3amp

The Atmos Multi is supplied factory wired complete with 1.2m of mains cable. All electrical connections to the mains supply must be made in full accordance with the current I.E.E. regulations.

The boiler must be earthed and connected via a double pole isolating switch fused to 3 amp or alternatively, by the use of a 3 amp fused three pin plug and unswitched shuttered socket outlet. The point of connection must be readily accessible, adjacent to the appliance and provide complete electrical isolation for the boiler and control system.

6.3 Flue terminal clearances.

The flue terminal must be sited with minimum clearance distances as specified in figure 3.

A terminal guard (available from Atmos Heating Systems) must be fitted if the terminal is sited less than 2m above ground level.

Where the flue terminates within 1m of a plastic or painted gutter or within 500mm of painted eaves then protection should be provided in the form of an aluminium shield at least 1m in length, fitted to the underside of the gutter or painted surface.

Please note !

Due to the low flue gas temperature, 'pluming' will occur at the flue terminal. Care should be taken to ensure that the discharge plume will not cause annoyance to the customer or neighbours. It is generally recommended that flues should discharge vertically at roof level, where pluming is not normally a problem

6.4 Flue system.

The flue system must be installed in accordance with BS5440:1. Horizontal flue gas discharge pipe runs must always be installed with a minimum 0.5% incline towards the point of termination. This incline will prevent condensation from gathering in the flue gas discharge pipe, and will also reduce the chance of icicles forming over horizontal pipe ends in extreme weather conditions. On horizontal terminations the air supply pipe must be led to outside with a minimum 0.3% angle to prevent the ingress of rainwater. Similarly, provisions should be made to prevent the ingress of rainwater into the air supply pipe on vertical terminations.

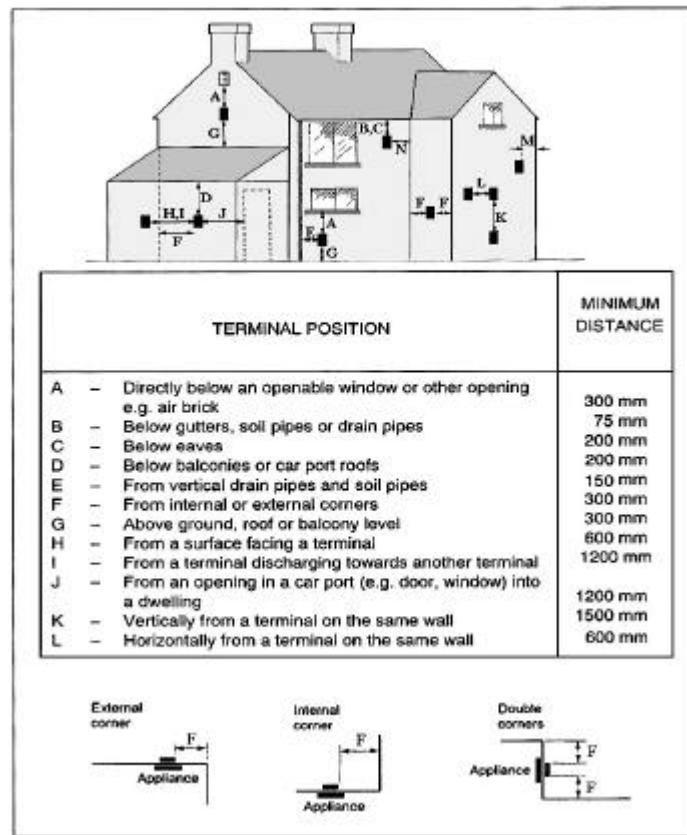

Figure 3: Flue terminal locations

Depending upon the boiler location and flue configuration required, two different flue systems are available for use with the Atmos Multi boiler:

- ❑ 125/80mm concentric system for use on vertical roof systems up to a maximum equivalent length of 64m, and;
- ❑ 80/80 twin pipe system which enables separate air intake and flue gas discharge pipes to be fitted to the appliance, allowing a combined total equivalent flue length of 64m

The maximum equivalent flue length of the flue system must not be exceeded. If exceeded the boiler will not malfunction but its heat-output capacity will be reduced. The connected gas/air regulator will however, always ensure optimum combustion is maintained.

Examples of various flueing options and configurations are given in figure 4.

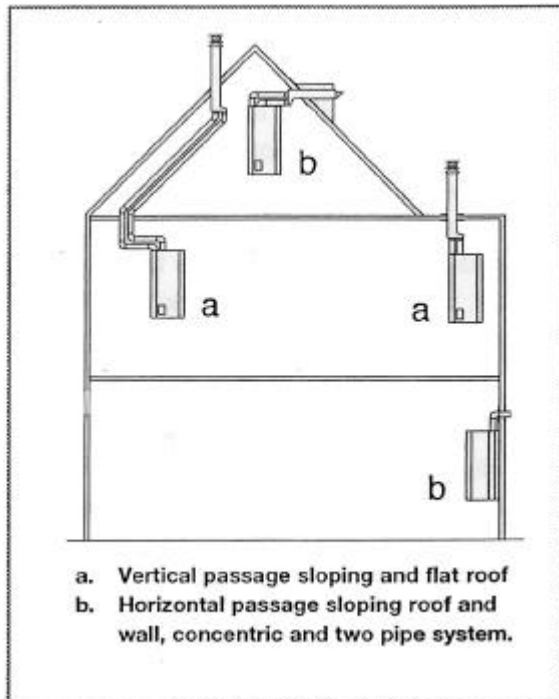

Figure 4: Examples of flueing options.

The equivalent length of the required flue system's configuration can be calculated from the resistance factors given for the individual flue components in table 3. In the worked example (fig 5) the maximum permitted combined length for a 80mm dia. twin flue is 64metres at a pressure of 100 Pa. Account has already been taken of the resistance of the balanced flue terminal. This can therefore be ignored in the calculation.

STRAIGHT LENGTH OF 1M	Ø 80 MM:	1 M
BEND 90°	Ø 80 MM:	3 M
BEND 45°	Ø 80 MM:	1 M

Table 3. Flue resistance factors

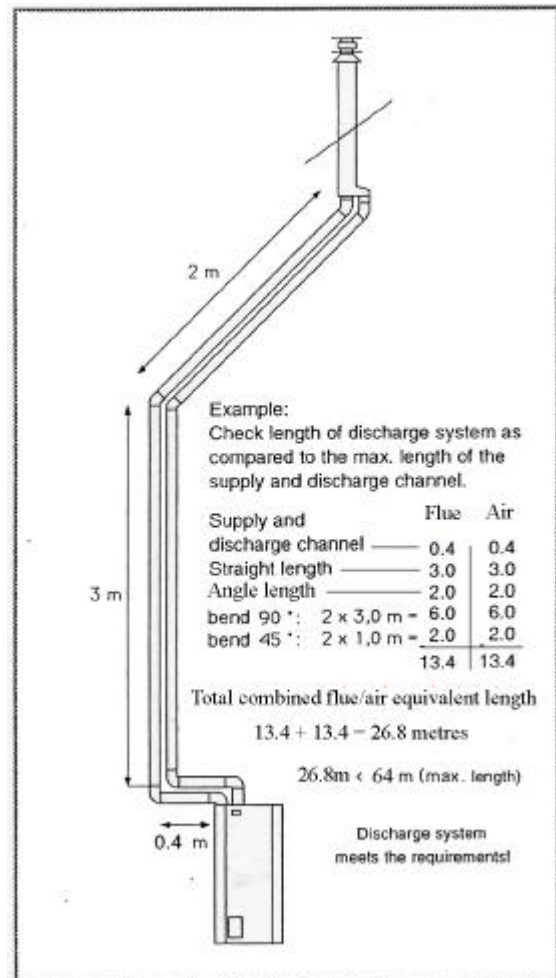

Figure 5: Worked flue length example.

6.5 Condensate disposal.

Provisions must be made for the safe disposal of condensate produced when the Atmos Multi is in operation. The condensate drainage pipework must be run in an acid resistant material such as plastic waste pipe. Copper or steel pipe must not be used. The pipework must incorporate a minimum 1:20 downward slope towards its point of termination, which ideally should be an internal soil or waste pipe to avoid the possible risk of freezing. Alternatively, where this not possible the condensate may be discharged into an external gully or purpose-built soakaway.

The condensate pipework must be protected against freezing and any pipework external to the property must be encased in waterproof insulation and be restricted to a maximum length of 3m.

6.5 Discharge pipes.

It is a requirement of Building Regulation G3 that any discharge from an unvented system should be visible at both the tundish and final point of discharge. Where this is not possible or practical however, the discharge must be clearly visible at one of these locations.

The discharge pipe from the tundish should terminate in a safe place where there is no risk to persons in the vicinity of the discharge.

While it is permissible to combine the discharge pipes from the Atmos Multi temperature & pressure relief valve and expansion pressure relief valve, the tundish and Atmos Multi boiler must be located in the same space. The tundish must also be within 500mm of the combined temperature & pressure relief valve and installed in a vertical position.

While a minimum 300mm of vertical discharge pipe must exist below the tundish, the discharge pipe itself should be of metal construction and, unless its total equivalent length exceeds 9m, be one pipe size larger than the nominal outlet of the combined temperature & pressure relief valve.

Where the total equivalent length of the discharge pipe exceeds 9m the pipe must be increased by one pipe size for each additional 9m length. For example a discharge pipe having an equivalent length of between 9 and 18m must be two pipe sizes larger than the nominal outlet of the combined temperature & pressure relief valve, between 18 and 27m three pipe sizes larger, and so on. Bends must be taken into account when calculating the flow resistance. See Figure 6 and Table 4 for a typical discharge arrangement and worked example.

Note. An alternative approach for sizing discharge pipes would be to follow BS 8700: 1987 *Specification for design installation, testing and maintenance of services supplying water for domestic use within buildings and their curtilages. Appendix E, section E2 and tables 21.*

The discharge pipe must be installed with a continuous fall towards its point of termination, which ideally should be below a fixed grating and above the water seal in a trapped gully. Where this is not possible or practical then the discharge pipe may terminate either:

- ❑ At low level discharge above external surfaces such as car parks, hard standings, grassed areas and so on, providing that termination is a maximum of 100mm above the surface and a wire cage or similar guard is fitted to prevent contact with any discharge, while still maintaining visibility, or;
- ❑ At high level into a metal hopper and metal down pipe with the end of the discharge pipe being clearly visible or alternatively, onto a flat roof capable of withstanding high temperature discharges of water. Such termination however, must not be within 3m of any plastic guttering and the tundish must be clearly visible in order to detect any occurrence of discharge.

In cases where a single common discharge pipe serves a number of units, such as in a block of flats, the number of units served should be limited to a maximum of six. The common discharge pipe should be at least one pipe size larger than the largest individual discharge pipe to be connected.

Where the Atmos Multi is installed in a property where discharge from the unit may not be apparent, such as in the case of blind, infirm or disabled people, then consideration should be given to the installation of an audible electronically operated device to warn when discharge takes place.

Combined Safety discharge and condensate pipe

Subject to the approval of the Local Building Inspector, the Safety discharge pipe and condensate discharge pipe may be combined into a single common discharge pipe. A schematic layout for such an arrangement is given in Appendix 2 of these instructions.

Figure 6: Typical discharge arrangement

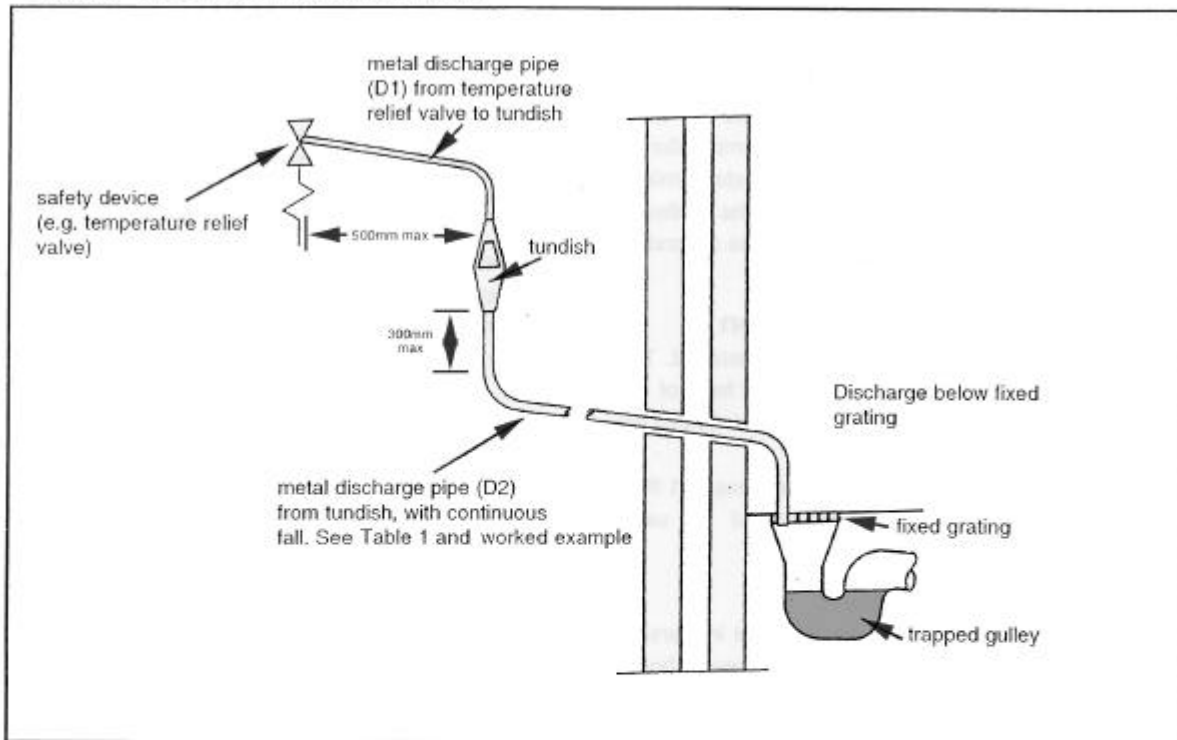

Table 4. Sizing of copper, discharge pipe. D2 for common temperature relief valve outlet sizes

Valve outlet size	Minimum size of discharge pipe D1*	Minimum size of discharge pipe D2* from tundish	Maximum resistance allowed, expressed as a length of straight pipe (i.e. no elbows or bends)	Resistance created by each elbow or bend
G1/2	15mm	22mm	up to 9m	0.8m
		28mm	up to 18m	1.0m
		35mm	up to 27m	1.4m
G3/4	22mm	28mm	up to 9m	1.0m
		35mm	up to 18m	1.4m
		42mm	up to 27m	1.7m
G1	28mm	35mm	up to 9m	1.4m
		42mm	up to 18m	1.7m
		54mm	up to 27m	2.3m

*See 3.5, 3.9, 3.9(a) and Diagram 1

Worked example:

The example below is for a G 1/2 temperature relief valve with a discharge pipe (D2) having 4 No. 22mm elbows and length of 7m from the tundish to the point of discharge.

From Table 1

Maximum resistance allowed for a straight length of 22mm copper discharge pipe (D2) from a G 1/2 temperature relief valve is: 9.0m
 Subtract the resistance for 4 No. 22mm elbows at 0.8m each =3.2m

Therefore the maximum permitted length equates to 5.8m which is less than the actual length of 7m.

Therefore calculate the next largest size (28mm) .

Maximum resistance allowed for a straight length of 28mm-pipe (D2) from a G 1/2 temperature relief valve is: 18m

Subtract the resistance for 4 No. 28mm elbows at 1.0 m each = 4m Therefore the maximum permitted length equates to 14m. As the actual length is 7m a 28mm (D2) copper pipe will be satisfactory.

water inlet manifold, an 8 litre blue expansion vessel, safety valve and pipe connections and;

6.6 Existing systems.

All re-circulatory water systems are subject to corrosion unless an appropriate water treatment is applied. To prevent the risk of corrosion sludge accumulates within an existing system causing boiler noise and circulation problems along with possible pump and valve damage, existing heating systems must be thoroughly flushed to ensure that all sludge and debris is removed prior to installing the boiler.

Where a cleaning agent is used for this purpose only Sentinel X400 is recommended. Atmos Heating Systems do not recommend the any other cleaning agent. The use of non-recommended cleaning agents will invalidate the boiler's guarantee.

Note. When after flushing and cleaning of the system has taken place there is any possibility of any debris remaining in the system, it is recommended that a 'Y' strainer is fitted on the boiler Return pipe.

7. Boiler Installation.

7.1 Unpacking

Due to the boilers dry weight of 75kg it is recommend that either a sack barrow or two men are employed to carry the boiler to its chosen position. The boiler must be carried and stored horizontally on the wooden pallet provided. Under no circumstances must it be stored vertically.

The appliance is protected by a cardboard box and delivered as standard with:

- ❑ Mounting bracket
- ❑ Fixing pack consisting of 2 wall plugs, 2 bolts and 2 washers
- ❑ Burner inspection window
- ❑ Automatic de-aerator
- ❑ Siphon
- ❑ Template
- ❑ Guarantee registration card, Operating instructions and Installation instructions

In addition the boiler is supplied with;

- ❑ WRAC mains water kit including UV3 cold

- ❑ Robokit sealed system expansion vessel including wall bracket and safety valve.

Using a knife, cut open the bottom tray of the box and remove the top box from the bottom tray (fig. 7).

Figure 7: Unpacking boiler

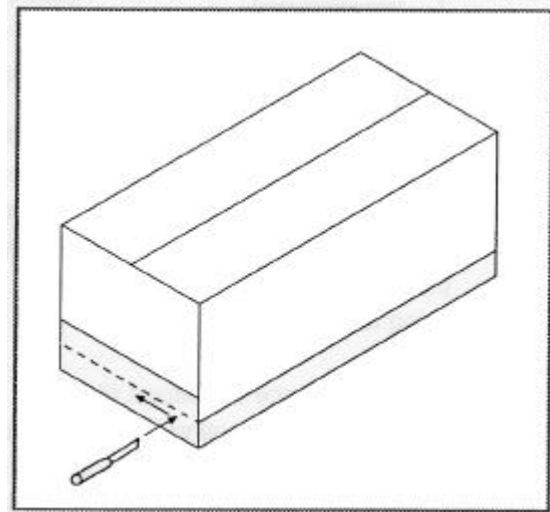

Check the appliance immediately after unpacking. Any damage must be reported immediately to your supplier.

The packaging consists of corrugated cardboard, wood and cellulose oil, and can therefore be recycled as waste paper. Do not throw away the packaging, but ask the local refuse collection service where it can be taken.

Remove the appliance casing to prevent accidental damaged during installation as follows (fig. 8):

- i) Remove the two screws 'a' of the control panel.
- ii) Unclick the catches 'b' at the top and bottom of the appliance and remove case by lifting upwards.

Figure 8: Removing the appliance case.

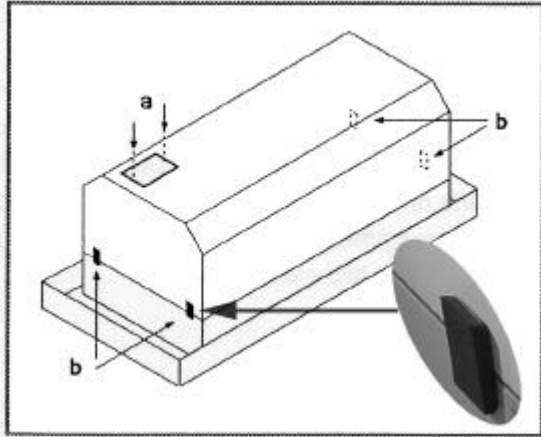

7.2. Minimum clearances.

For servicing and maintenance purposes, a minimum clearance of 600mm to the front, 150mm above, 750mm below and 100mm to either side of the boiler case is required. (fig. 9 & fig 10)

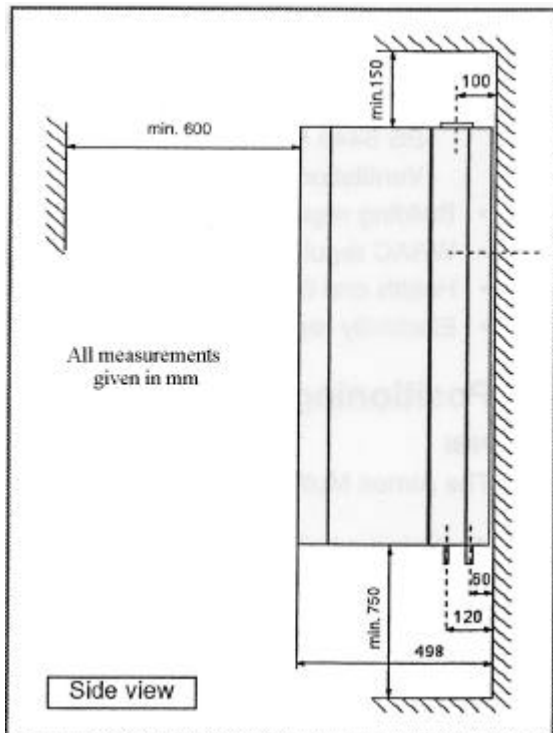
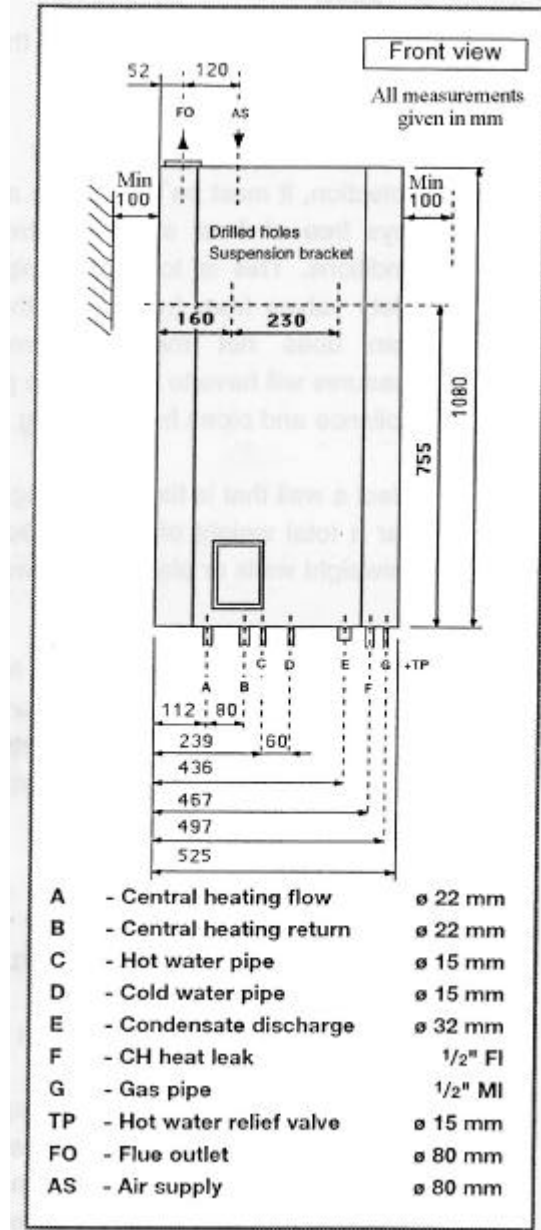

Figure 9: Dimensions & minimum clearances

Figure 10: Dimensions & minimum clearances



7.3 Boiler location.

The Atmos Multi is not suitable for external installations.

While the appliance itself is provided with integral frost protection it must however, be installed in a room that stays free of frost even in extremely cold conditions. This is to prevent pipes or the safety valves from freezing. If the selected room does not

meet this requirement, measures must be taken to protect the safety valves and pipes against freezing.

The appliance must be installed on a flat vertical wall that is capable of taking the weight of the boiler. Do not fix directly onto low load bearing or plasterboard walls.

For low load bearing and plasterboard walls a special designed mounting frame incorporating support legs should be employed. Contact Atmos Heating Systems for this optional item.

On a lightweight block wall, heavy duty Rawplugs must be used in place of the supplied wall plugs and bolts.

The boiler may be fitted on or adjacent to a wall comprising of a combustible material without the need for a special thermal insulation barrier.

Due to the appliance being self-ventilating, it remains relatively cool during operation. Generally there is no requirement to provide purpose made ventilation to an airing cupboard or compartment in which the appliance is installed

A cupboard or compartment used to enclose the appliance must however, be designed and constructed specifically for the purpose and comply with Building Regulations. The cupboard or compartment must also be of sufficient size to permit access for inspection and servicing or removal of the boiler.

7.4. Wall mounting the boiler

Taking into account the clearances required for servicing and maintenance, tape the provided template onto the chosen wall position, ensuring it is level and the correct way up.

Mark the position of the fixing holes for the boiler mounting bracket. Drill the fixing holes using a 16mm drill bit and fit the mounting bracket using the supplied fixing plugs and bolts.

Warning : The fixings supplied are suitable only for brick or solid block walls. When full the Atmos Multi weighs 150kg and must not be fitted directly onto walls with low load bearing capacities.

Fit the appliance onto the mounting bracket as follows (fig. 11):

- a. Place the mounting indication point level with the top side of the mounting bracket and position the corners of the back of the casing level with each end of the mounting bracket.
- b. Put the bottom of the boiler against the wall.
- c. Carefully lower the appliance onto the wall bracket.

Note!

A lifting handle with red plastic covers on each end is provided for lifting the boiler onto the mounting bracket. Do not lift with other parts of the boiler, as it may cause damage. To comply with Health & Safety Regulations, Atmos Heating Systems recommend that the boiler be lifted into position by the use of two men.

Figure 11: Mounting the boiler

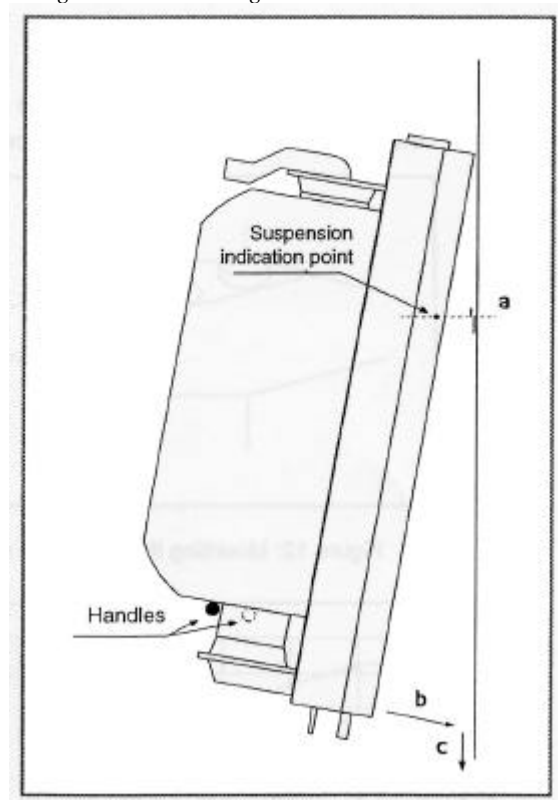

For concentric and vertical roof systems refer to separate installation instructions supplied with the flue assemblies.

7.5. Connecting the flue system.

Prior to connection of the boiler's flue system please refer to sections 6.3 & 6.4 of these instructions.

The flue and air duct supplied by Atmos Heating Systems are an integral part of the boiler and care must be taken on their installation to ensure that all joints are airtight and correctly made.

The standard horizontal flue kit supplied with the boiler consists of a twin pipe terminal plate, an 850mm length of 80mm diameter aluminium duct and two 90° bends.

The flue and air ducts may be extended by means of extensions, (available on request from Atmos Heating Systems) to a maximum combined length of 64m. The use of each additional 90° or 45° bend however, reduces the maximum permitted flue length by 3m and 1m respectively.

The duct and fittings are push fitted together being sealed by the fittings integral 'O' ring. (fig 12).

On assembly it must be ensured that aluminium duct is square and burr free prior to being pushed into the fitting. Failure to do so may result in damage to the sealing 'O' ring.

When connecting to the twin pipe terminal plate it is important to ensure that the plate is fitted the correct way up and the flue discharge and air inlet ducts are connected to the correct terminal. (fig 13)

On installing the flue system it is recommended that a 85mm diameter core drill is used when cutting through the properties external wall.

Figure 12: Twin pipe joint



Figure 13: Twin pipe terminal plate

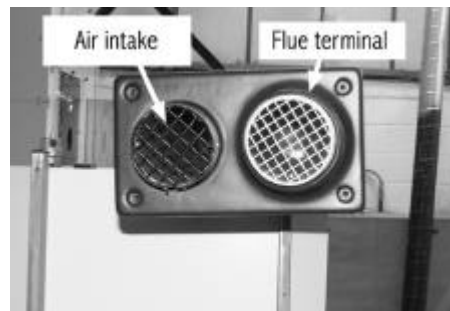

The system must comply with the requirements of BS5449 and to avoid corrosion and leaks, be airtight, closed and connected in accordance with Benchmark procedure.

7.6. Connecting the central heating circuit.

Important Note!

The Atmos Multi is suitable for use on a sealed heating system only. It must not be connected to an open vented heating system.

22mm diameter connections for the central heating circuit flow and return pipes are located on the underside of the appliance. (fig 14) The flow pipe being colour coded red, the return pipe colour coded blue.

Figure 14: Boiler flow & return connections.

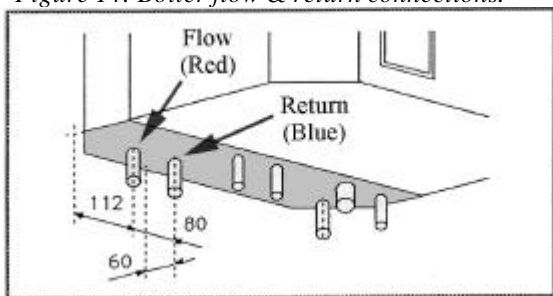

Locate and fit the separately supplied automatic air vent to the boiler's top right corner (fig 15). Once fitted loosen the automatic air vent's cover cap.

Figure 15: Automatic air vent

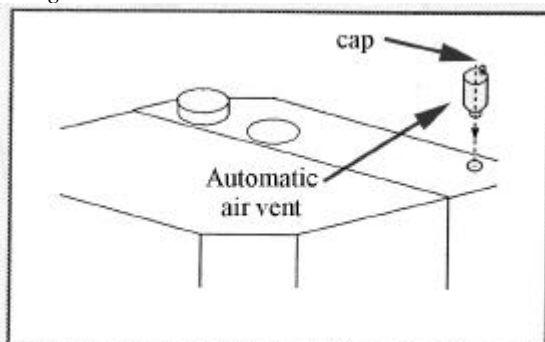

Before connection to the central heating system the system must be thoroughly flushed in accordance with the guidance given in BS7593.

When connecting the boiler to a heating system containing plastic pipework the following must be noted:

- ❑ In a floor heating system, the plastic hoses/pipes used must either meet BS7291 having a class 'S' rating or DIN 4726/4729 having an air permeability less than 0.1 g/m³ at 40°C.
- ❑ In a radiator system, the plastic hoses/pipes used must either meet BS7291 having a class 'S' rating or DIN 4726/4729 having an air permeability less than 0.1 g/m³ at 85°C in a twenty four hour period.

Connection of the Atmos Multi to a heating system containing non-diffusion barrier oxygen permeable plastic pipe or class 'H' plastic pipe will invalidate the boilers guarantee.

It is important that there is a by-pass on the central heating circuit to ensure that the system water is able to flow through the boiler's heat exchanger at all times. This may be achieved by leaving at least one radiator permanently open. Alternatively, a pressure differential regulator valve (fig 16) that provides an automatic system by pass is available on request from Atmos Heating Systems.

Figure 16: Pressure differential regulator valve

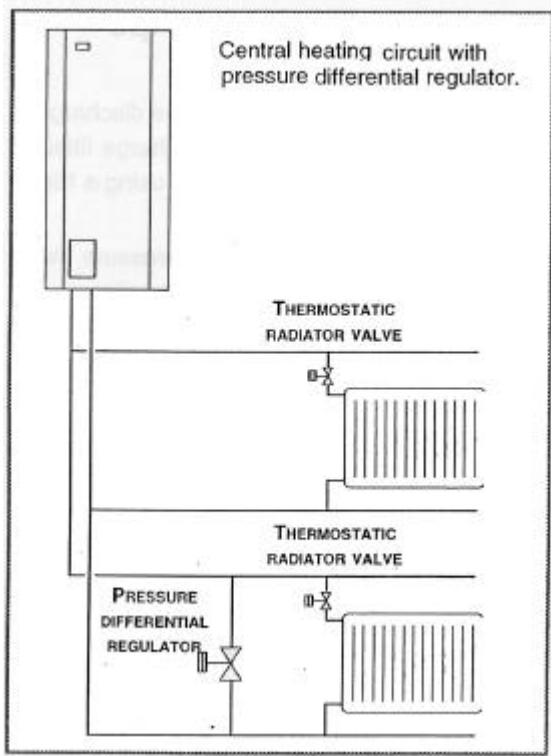

A sealed system 'Robokit' is supplied with each Atmos Multi boiler. Expansion vessels are available in 8,12 or 18 litre sizes with the Robokit, and are coloured RED. Table 5 provides guidance

to the size of expansion vessel required for systems fitted with steel panel radiators in a two-storey house. Consult Atmos Heating Systems for further information and advice for non-standard systems.

Note. The red primary expansion vessel must not be confused with the blue secondary expansion vessel intended for use on the domestic hot water circuit.

Table 5: Required expansion vessel

Expansion vessel size in litres	System primary water capacity	Approximate system output	Approximate number of radiators
8	90 litres	10 kW(34,000 Btu/hr)	8
12	140 litres	15 kW(51,000 Btu/hr)	12
18	200 litres	20 kW(68,000 Btu/hr)	16

Where required, the boiler offers the facility for an independent towel rail circuit to be installed via the purpose supplied towel rail connection (fig 16a) This allows for the separate heating of a radiator when the boiler is operating in either central heating or hot water mode. To prevent hot water circulation within the central heating system when the boiler is operating in domestic hot water only mode, the towel rail circuit return must be the last connection on the return pipe to the boiler.

Note. When utilised, the towel rail circuit must be carefully balanced to avoid short-circuiting of the main central heating system.

Figure 16a Towel rail connection

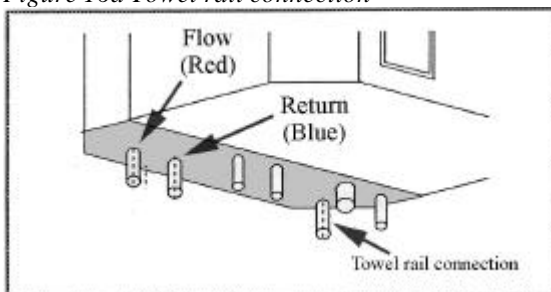
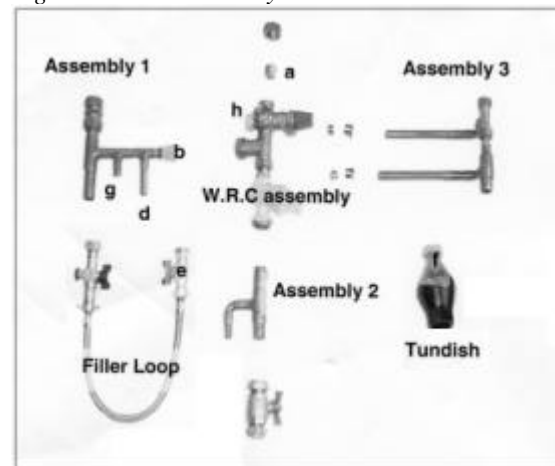

Figure 17: Pre-assembly kit



From the pre-assembly kit (fig 17) select the **Assembly 1** and fit to the 22mm central heating return on the boiler, utilising the 22mm compression straight connector supplied.

Using the wall bracket supplied, fit the **Red** expansion vessel to the wall in close proximity to the boiler. Connect the expansion vessel to the 15mm pipe connection g. This can be with either 15mm copper tube or alternatively, using optional

flexible hose connections available as an optional extra from Atmos Heating Systems. The connection to the expansion vessel utilises a ¾ female x ½ male threaded adaptor and the washer provided must be fitted internally. The other end has a 15mm compression fitting.

The mains pressure kit must be assembled as shown in fig 18 in the following manner:

Figure 18: Mains pressure kit assembly

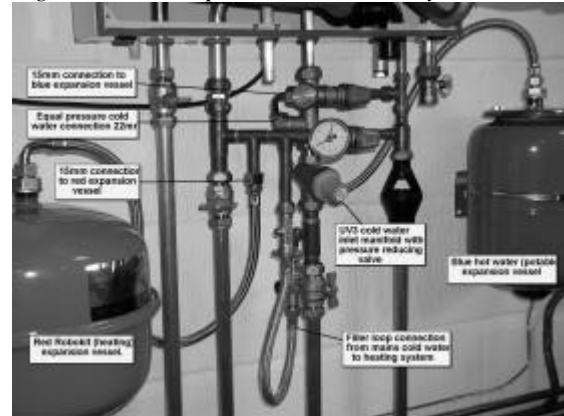

Fit the filler loop from the cold water main to the second 15mm pipe connection d, ensuring that the loop is fitted in the right direction as indicated on the arrow stamped on the non-return valve.

Fit the heating system safety valve into the ½" BSPF connection, pointing in the direction shown ready for connection into the discharge pipe. (fig 18)

7.7.Connecting the mains cold water.

Each Atmos Multi boiler is supplied with a mains pressure kit comprising the following components:

- ❑ UV3 manifold including pressure reducing valve pre-set at 3.5 bar. (Altecnic)
- ❑ ½" Caleffi safety relief valve set at 6bar.
- ❑ 8 litre blue potable expansion vessel (Altecnic)
- ❑ Expansion vessel mounting bracket.
- ❑ 22mm x 15mm compression reducing set.
- ❑ Black plastic tundish. (Altecnic), and;
- ❑ ¼" BSPM drain cock.

- ❑ Connect the UV3 manifold to the boilers 15mm cold water inlet supply pipe (colour coded blue), using the 22mm x 15mm compression reducing set supplied.
- ❑ Connect the 22mm incoming cold water main supply to the inlet of the UV3 combined 22mm stop tap and pressure reducing valve.
- ❑ Locate and fit the 6bar safety relief valve, by push fitting into its fixing socket on the UV3 manifold. A small grub screw located in the side of the manifold is provided to lock the valve in position, by means of the Allen key provided.
- ❑ The 22mm branch 'E' is provided for the cold water system of the house, where equal hot and cold water pressures are required. If this facility is not required, the branch may be blanked off using the blanking plug provided.
- ❑ Locate and fit the supplied ¼" BSPM drain-off cock to the manifold's socket 'G'. The fitting of this drain off cock enables 90% of the water content of the hot water tank to be drained.
- ❑ Fix the Blue 8 litre potable expansion vessel adjacent to the 'primary' heating expansion vessel using the wall brackets provided.
- ❑ Connect the potable expansion vessel's ¾" boss to connection 'H' on the UV3 manifold using 15mm

copper pipe.

Important Note!

Under no circumstances must any valve be installed between the expansion vessel and connection 'H' on the UV3 manifold.

- ❑ Connect the 6 bar safety valve discharge pipe as described in Section 7.6 of these instructions.

Warning! Failure to install the above components correctly is dangerous, and renders the system unsafe. Furthermore the copper tank guarantee is invalidated.

7.8.Connecting the safety discharge pipes.

The safety discharge pipes must be assembled as shown in fig 19 in the following manner:

Figure 19: Safety discharge pipes

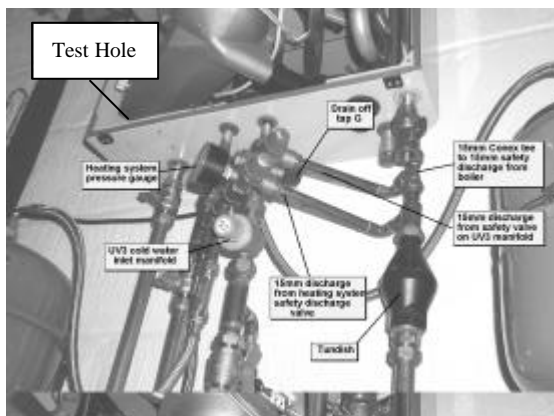

- ❑ Connect the boiler's integral temperature & pressure relief valve discharge outlet and the discharge outlet of the 6 bar pressure relief valve fitted to the UV3 manifold, by means of a 15mm

copper tee and pipe.

- ❑ Connect the black tundish as illustrated. The tundish must be located in a position where it is clearly visible to the householder and away from any electrical devices or wires.
- ❑ Connect the 'primary' heating expansion vessel's pressure relief valve discharge outlet to the under side of the tundish using a 22mm x15mmx 22mm copper tee
- ❑ A straight vertical pipe with a minimum length of 300mm must be provided below the tundish before the fitting of any bends.
- ❑ The discharge pipe must be ran to an external drain, terminating in a safe place where there is no risk to persons in the vicinity of the discharge. The discharge pipe must consist of metal, preferably copper.
- ❑ If the length of discharge is more than 9m equivalent length (a bend has an equivalent length of 0.8m) a larger pipe must be fitted. (see Section 6.5 of these instructions).
- ❑ The discharge pipe must have a continuous fall towards its point of termination, in order to drain effectively.

- ❑ The discharge pipe point of termination should ideally be below a fixed grating and above the water seal in a trapped gully. If this is not possible then refer to Section 6.5 of these instructions for acceptable alternative discharge terminations.

- ❑ The discharge pipe must not be used for any other purpose.

7.9.Connecting the domestic hot water supply.

The cold water inlet and hot water outlet connection points for supplying domestic hot water are located on the underside of the appliance (fig 20). The cold water inlet being colour coded blue, the water outlet colour coded red.

Figure 20: Hot water connections.

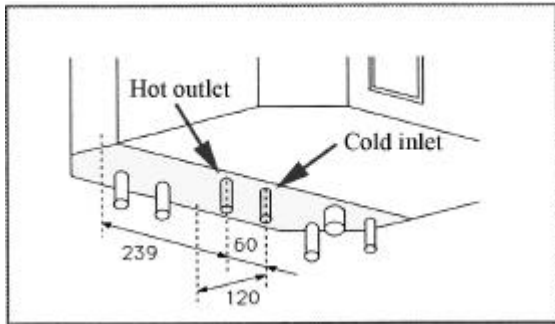

The cold water inlet to the boiler must be made via the UV3 manifold. The properties hot water supplies are connected to the boiler via the 15mm diameter hot water outlet connection.

The boiler's minimum domestic hot water temperature setting is 60°C., the installation of a thermostatic mixing valve is recommended to reduce the hot water temperature at the tap.

7.9 Hot water secondary circulation.

While there is no separate secondary return connection on the boiler, a secondary re-circulation loop may be installed. Where required, the secondary return should be taken to the cold water feed of the storage tank, immediately after the UV3 manifold. The return must not pass through the UV3 manifold. If the secondary return loop has a volume in excess of 1 litre, a larger potable expansion vessel should be used. Contact Atmos Heating Systems for further advice.

A non-return valve must be fitted to the return loop to prevent the back flow of cold water to the hot water taps. (Fig 20a)

Figure 20a Hot water secondary circulation

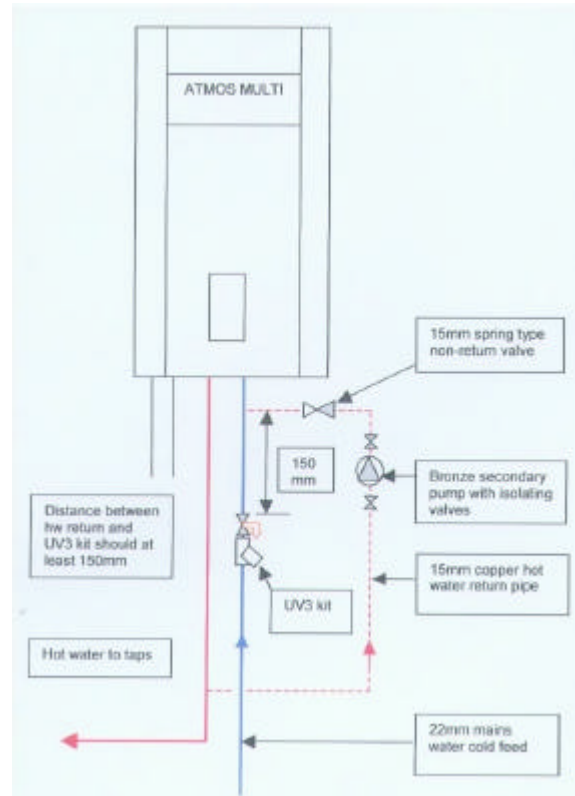

7.10. Connecting the gas supply.

The gas pipe inlet connection is located on the underside of the appliance being colour coded in yellow. (Fig 21)

Figure 21: Gas inlet connection

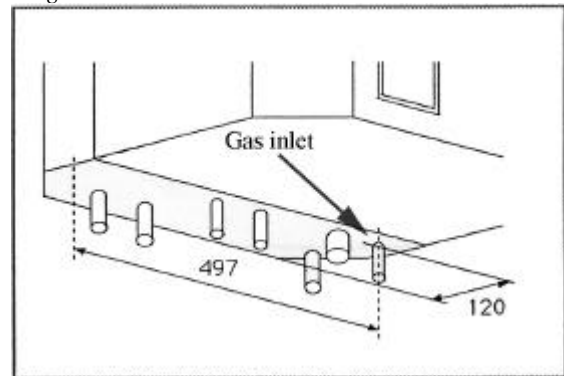

Check the boiler's data plate to ensure that the appliance has been set for the correct gas supply. The boiler is available for either Natural Gas (G20) or propane (G31).

For Natural gas the supply pipe must have a minimum diameter of 22mm. The meter governor should deliver a dynamic pressure of 20mbar for natural gas or 37mbar for propane.

The ¼ turn gas tap provided must be fitted immediately to the boiler to enable complete gas isolation to the boiler during maintenance and servicing work.

To prevent the ingress of foreign matter and possible damage to the gas-regulating block, the gas supply pipe must be checked for contaminants prior to connection to the boiler.

On final connection of the gas supply to the boiler, the complete gas installation, including the meter, must be tested for gas soundness and purged as described in BS6891.

7.11. Connecting the condensate siphon

The connector for the condensate water discharge is located on the underside of the appliance (fig. 22).

Figure 22: Condensate connection.

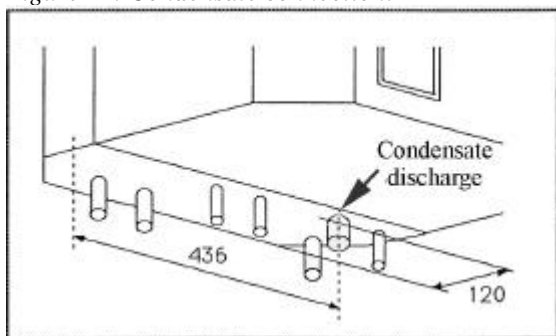

Locate and connect the supplied siphon to the boiler's condensate drain connection via 32mm dia plastic pipe. The siphon should be fitted so its outlet is angled towards the rear wall and left with an open connection to the purposely installed 32mm dia condensate drainage pipe work. (fig 23)

For condensate drainage pipework refer to Section 6.5 of these instructions.

Figure 23: Condensate discharge arrangement.

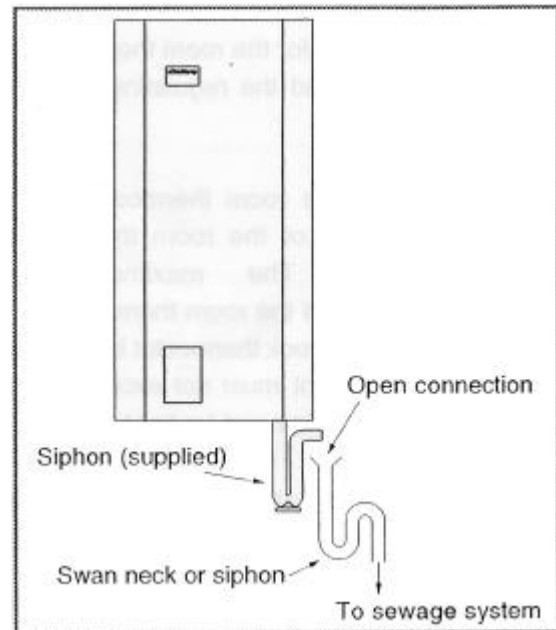

7.12. Connecting the mains electricity.

Warning! The electrical wiring of the Atmos Multi is complete and must not be changed or adapted in any

All electrical connections to the mains supply must be made in full accordance with the current I.E.E. regulations.

The boiler must be earthed and connected via a double pole isolating switch fused to 3 amp or alternatively, by the use of a 3 amp fused three pin plug and unswitched shuttered socket outlet

Where possible, it is recommended that the appliance is protected against electrical surges by the fitting of an anti-surge device.

On connection it is essential that correct polarity be observed. If polarity is reversed, the control unit will lock and a malfunction alert 'L' will be displayed on the control panel. Should this occur, the wiring must be reversed to its correct polarity and the boiler re-started

A facility for the connection for a 24V AC room is

located behind the control unit front fascia.

Important Note!

Under no circumstances must any electrical power be input to the room thermostat terminals.

Care must also be taken to avoid induced voltages caused by the running of the thermostat cables along side other main voltage cables.

Where a 'wireless' room thermostat is employed consult the thermostat's manufacturer instructions for installation.

A wiring diagram of the Atmos Multi is given as figure 24.

On connection the room thermostat's heat accelerator must be set at 0.12A. The maximum permissible resistance of the room thermostat circuit is 22 Ohms. Where a clock thermostat is employed, the closed-circuit current must not exceed 20mA when there is no demand for heat.

It is recommended that the room thermostat is not set lower than 15°C during the winter months.

Figure 24: Atmos Multi wiring diagram.

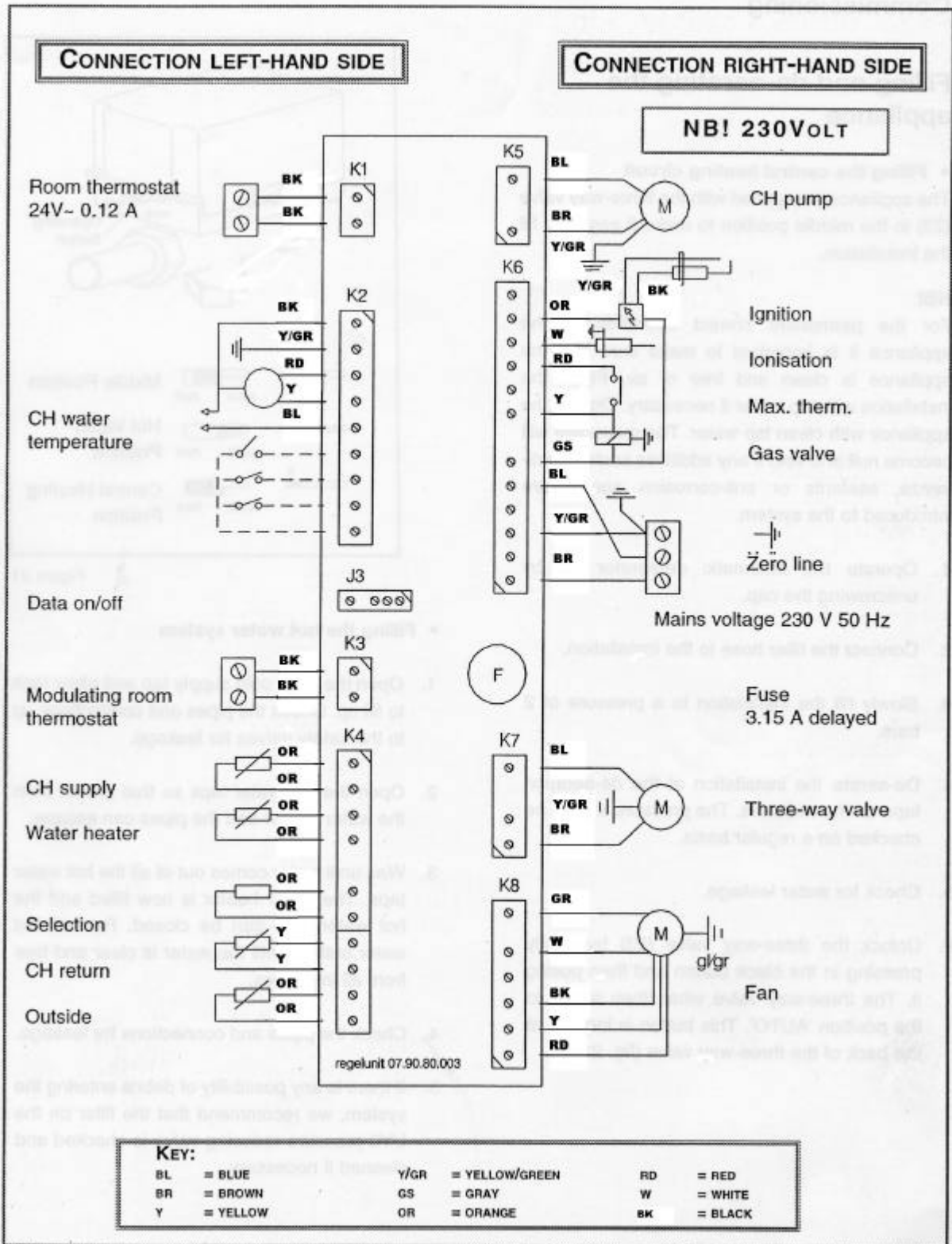

8. Commissioning.

every boiler and advise that they are filled in during the commissioning procedure.

Note: We include Benchmark Logbooks with

8.1 Filling the heating system.

Warning! The Atmos Multi must not be operated in a waterless condition.

On completion of the boiler installation and ensuring that all water connections are correctly made and tight, the boiler may be filled with clean water by fitting the supplied filling hose and opening the two Robokit manual filling valves. (fig 25)

Figure 25: Filling hose connection.



On filling:

- ❑ Ensure that the boiler's automatic air vent sealing cap is loose.
- ❑ Slowly fill the installation until a system pressure of 2bar is obtained.
- ❑ Vent each system radiator and purpose fitted air vent in turn starting with the lowest in the system. The system pressure should be regularly monitored during this process and topped up when required.
- ❑ Air must be vented from the boiler pump by unscrewing the pump's integral vent plug (fig 26) and allowing water to bleed for a few seconds, taking care not to allow water to splash onto the boiler's electric parts. This process may have to be repeated two or three times during the filling process.

Figure 26: Venting the pump



- ❑ Test the operation of the system's outlet safety valve by turning the valve knob anti-clockwise until water is released, at which point the valve must be closed and re-set.
- ❑ Continue to fill the system until all air has been expelled, leaving the system pressure at a nominal 2bar.
- ❑ Check the system for water soundness, rectifying where necessary and remove the system filling hose.

Figure 27: Three-way valve

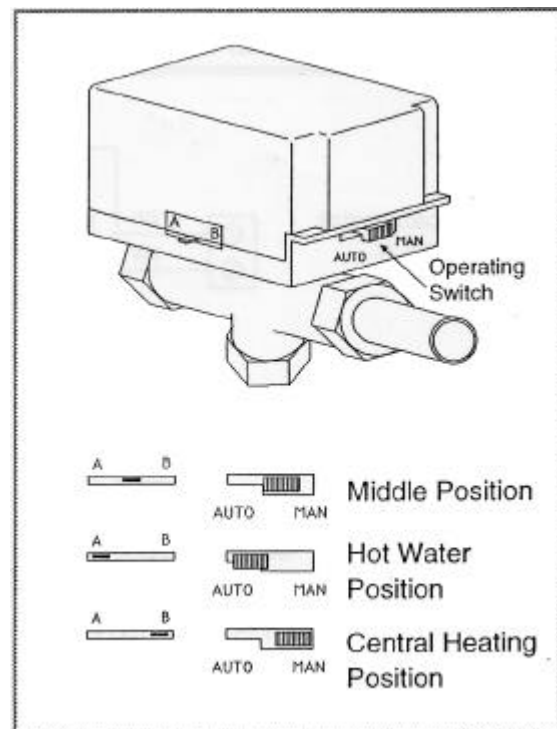

To aid filling the boiler is supplied with its integral three way valve locked in the middle position. On completion the valve must be unlocked by lightly

pressing and then pulling the black button located on the rear of the valve. (fig. 27).The three way valve will then return to the 'Auto' position.

Where required Sentinel X100 may be added to the system water in accordance to its manufacturer instructions. Atmos Heating Systems do not recommend the use of any other inhibitor or additive. The use of a non-recommended inhibitor or additive will invalidate the boiler's guarantee.

Note! For existing central heating systems the final system water must have a pH value of between 6.5 and 8.

8.2 Filling the domestic hot water system.

- ❑ Open the UV3 combined stop tap and pressure reducing valve and allow the storage tank to fill with water. Check the pipework and connections up to the safety valves for leaks.
- ❑ Vent the domestic hot water system by opening all hot water outlets until water is discharged.
- ❑ Turn off the hot water outlets once the discharge water is clear and free from impurities.
- ❑ Check the system for water soundness, rectifying where necessary.

Note! If there was any possibility of debris entering the domestic hot water circuit during filling, the filter on the UV3 pressure-reducing valve must be removed and cleaned as necessary. (fig 28)

8.3 Appliance operation.

The appliance may be put into operation by the follow procedure:

- ❑ With the appliance manual gas tap in the 'off' position, switch on the electrical supply to the boiler. If a letter 'L' appears on the diagnostic display the boiler has been wired with reversed polarity.
- ❑ Check that the water pressure in the central heating circuit is approximately 2 bar at the appliance. If the central heating water pressure is below 0.5 bar or higher than 3 bar a letter 'C'

Figure 28: UV3 cold water filter



alternating with the work status of the appliance will be shown by a warning report on the diagnostic display. (see Section 12.). If this report is shown the appliance will only run at its minimum capacity.

- ❑ Switch off the domestic hot water heating by pressing the 'Hot water' button on the operating panel. The 'on' indication light will go out.
- ❑ Open the appliance gas tap and purge the gas supply if necessary via the measurement nipple provided for measuring the pre-pressure (fig. 29).

Figure 29:

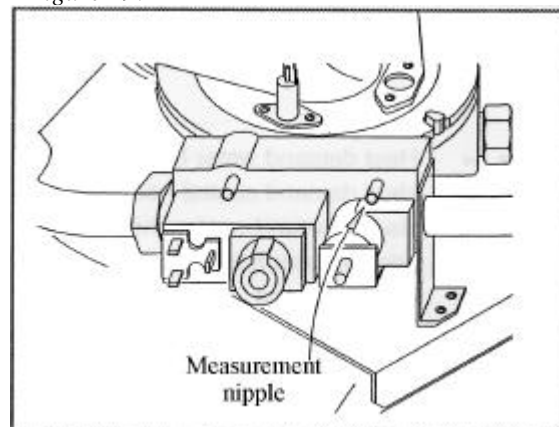

- ❑ Set the room thermostat at its highest position. The appliance will now start (status report Code 2°). If the hot water temperature is under 8°C, the frost protection will cut in and the boiler will automatically

revert to raising the hot water temperature above 15°C (status report Code 3•).

Note! If air is still present in the gas supply, the boiler's burner may attempt to ignite once or several times. After four start attempts a flame malfunction will be indicated (flashing 3•). If this occurs, unlock the control unit by pressing the reset button. The appliance will now run for the first 3 minutes at the lowest capacity and will switch to its maximum capacity until the central heating water temperature has fallen below 80°C. The appliance modulates between 80°C and 90°C.

❑ If the boiler's burner fails to ignite after 3 reset attempts, re-purge the gas supply, using the pre-pressure measurement nipple. Otherwise consult the Atmos Multi Service Manual.

❑ Ensure that the appliance is functioning correctly by undertaking the following inspections and noting the results and work carried out on the Service Card located on the front of the boilers storage tank insulation shells:

1. Visual inspection of the combustion flame
2. Measurement of the gas flow rate by watch & meter.
3. Measurement of either the O₂ or CO₂ percentage concentration within the flue gases by flue gas analysis.
4. Measurement of gas pre-pressure

❑ The procedure required to undertake inspections 1, 2 & 3 are detailed in Section 10 of these instructions. The procedure for inspection 4 is as follows:

❖ The measurement of gas pre-pressure must be taken during burner operation at maximum heat input via the measurement nipple provided on the gas valve. (fig 22). The gas pre pressure reading must be at least 20mbar.

❑ Check the burner's gas rate by stopwatch and meter. On the maximum input of 24kW or 32kW (depending on boiler model) the time taken to use 24 litres or 32 litres of gas respectively should be 33 seconds (± 2seconds.)

Note! The appliance burner pressure is factory set and sealed. The burner pressure can only be measured using precisely calibrated CO₂ or O₂

measuring instruments. If an inaccuracy is found when checking the appliance gas rate then consult the separately available Atmos Multi Service Manual or contact Atmos Heating Systems.

❑ Set the room thermostat to its minimum setting.

❑ Switch on the hot water heating by pressing the hot water button. The 'on' indication light will illuminate. The three-way valve will switch over to the water heater position and the burner will ignite to the stored domestic hot water. (status report Code 1•).

❑ While the stored domestic water is heating, check that expansion water is entering the tundish of the discharge system.

❑ Reset the room thermostat back to the desired position.

Note!

If during the heating of the stored domestic water the room thermostat also makes a demand for heating, the hot water and central heating demand will be met simultaneously (status report Code 4•).

The following codes may also appear on the diagnostic display during the commissioning process:

- (1•) Heat demand water heater
- (2•) Heat demand central heating
- (3•) Heat demand water heater and C/heating, priority water heater heating
- (4•) Heat demand water heater and C/heating, supply to both.

8.4 System balancing.

For efficient boiler operation the heating system must be correctly balanced to ensure that all

radiators are heating up evenly and a required temperature differential of 20°C is present between the boiler's heating flow and return connections.

The required water flow rate through the appliance is 0.8 m³/h and 1.2 m³/h for the Atmos Multi 24 and 32 models respectively. The maximum permissible system resistance to enable the boiler pump to achieve these flow rates is 3.1m and 2.1m respectively. (fig 30)

Figure 30: Available pump outputs

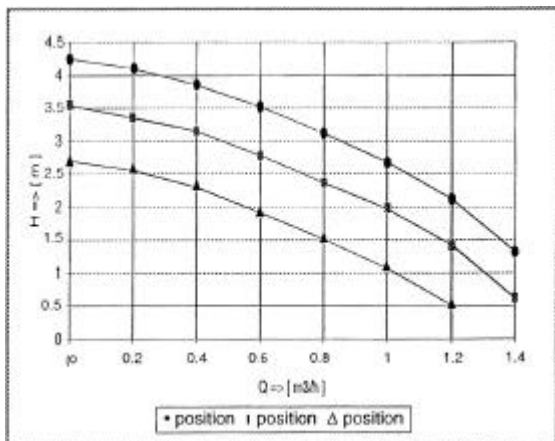

9. System shutdown.

9.1 Central heating circuit.

- ❑ Leave the appliance connected to the main electrical supply.
- ❑ Turn the room thermostat to its minimum setting. The domestic water heater will remain at its set temperature setting.

Note! On shutting down the central heating system it is recommended not to set the room thermostat lower than 15°C during the winter months. To prevent the installation from freezing it is recommended leave all radiator valves fully or partially open.

9.2 Domestic hot water.

- ❑ Leave the appliance connected to the main electrical supply.
- ❑ Switch off the domestic hot water by pressing the 'Hot water' button. The 'on' indication light will go out. (The stored water is protected against freezing in winter months by an automatic frost protection that activates on a

water temperature of 15°C).

Note! The heating and domestic hot water installation must be independently protected from frost. The boiler's built-in frost protection facility will only safeguard the appliance itself.

9.3 Draining the boiler

Hot water tank

- ❑ Turn off the cold water mains stop tap and open the domestic hot taps.
- ❑ Connect a flexible hose from the black drain tap on the UV3 manifold, into the tundish. The water from the hot water tank will now flow into the waste pipe via the funnel of the Safety Valve group.

Alternatively, the tank may be drained via the safety valve on the UV3 manifold. The valve head should be rotated through 90° and held open until water stops flowing.

Central heating circuit.

- ❑ Switch off the boiler electrical supply.
- ❑ Set the three-way valve (fig 27) at the middle position by pressing in the black button until it locks
- ❑ Allow the installation to drain using the purpose fitted drain cocks.

9.5 Disposal of the appliance

The Atmos Multi is made of a number of primary materials, especially copper, aluminium and steel. These materials can easily be separated and recycled at the end of the life span of the appliance. Therefore do not throw away the appliance, but make enquiries at your local council or a scrap dealer.

10. Routine Inspection and Servicing.

To ensure continued efficient operation of the Atmos Multi it must be checked and serviced as necessary at regular intervals. The frequency of servicing depends upon the individual installation conditions and usage, but must be a minimum of once per year.

The extent of the servicing required is determined by the operating condition of the appliance when

tested by a fully qualified engineer.

Only competent engineers such as a Corgi registered installer must carry out any service work.

10.1 Boiler pre-service inspection.

Warning!

Turn off the boiler electrical supply before removing the appliance casing. The fan, gas valve, three-way valve and central heating pump are mains fed with 220V

The annual inspection of the boiler comprises of the following:

1. Visual inspection of the flame
2. The measurement of the O₂ or CO₂ concentration in the flue gas
3. Measuring the gas rate.
4. Inspecting the ionisation flow.
5. Inspecting the air inlet filter.
6. Inspecting the siphon.

Note! The inspection results and any servicing work undertaken must be noted on the service card located on the front of the hot water storage tank insulation shells.

1. Visual inspection of the flame

The flame must be assessed after one minute of combustion at the low position or high position.

❑ *Low position*

Viewed from top to bottom on the combustion seat the burner flame picture must have the presence of a light blue flame.

A completely red flame indicates that the supplied air/gas mixture is gas rich, an entirely dark blue flame indicates an air rich mixture.

If the flame picture is correct there is no need to measure the O₂ or CO₂ concentration of the flue gas and point 2 of the inspection can be left aside. If the flame picture is not correct, the O₂ or CO₂ percentage of the flue gas must be measured.

❑ *High position*

Viewed from top to bottom on the combustion seat the burner flame picture must have the presence of an entirely blue flame. The air/gas mixture setting of the high position are determined by the setting of the low position.

If the flame picture is not correct, the O₂ or CO₂ percentage of the flue gas must be measured.

2. Measuring the O₂ or CO₂ concentration of the flue gas.

The O₂ or CO₂ measurement of the flue gas must be undertaken using an analyser calibrated to a precision of < 0,2%.

Measurements of the flue gas O₂ or CO₂ concentration must be taken at both the burner's low and high input capacity settings. The low input setting must be the first measurement.

On initial start up the burner fires on high input capacity prior to reverting to low input capacity for 3 minutes. After which period the burner again reverts back to high input capacity.

The measured O₂ or CO₂ must fall within the limits given in table 6.

Table 6. O₂ and CO₂ limits

	O ₂ %	CO ₂ %
HIGH POSITION	4,5 - 5,5	8,6 - 9,2
LOW POSITION	5,5 - 7,0	7,8 - 8,6

Note the measured values on the service card situated in the inside of the appliance. Compare the new values with those measured when the appliance was put into operation and/or during the previous inspections. If the differences between the two values are considerable, consult the Atmos Multi Service Manual or contact Atmos Heating Systems.

3. Measuring the gas rate.

Check the burner's gas rate by stopwatch and meter. On the boilers maximum burner input of 24kW or 32kW (depending on boiler model) the time taken to use 24 litres or 32litres of gas respectively should be 33 seconds (± 2 seconds.)

Note! If the flue's 80mm-diameter gas discharge duct is longer than 10 metres at the gas rate will be adversely affected and the measured time will in this case increase by 2%.

Note the measured value on the appliance service card. Compare the measured time with the value(s) recorded last time the appliance was put into operation and/or the previous annual inspection.

If the measured time falls outside of the tolerances, inspect the air supply and flue gas discharge system and the heat exchanger of the appliance for soiling, and clean where necessary (see Section 10.3).

5. Measuring CO² percentage of the flue gases.

Use a Flue gas analyser with a precision of <0.2% to check the CO² percentage of the Flue gases.

Flue gas samples can be taken from the test hole at the left-hand side of the outlet casing. (See fig. 19)

6. Inspecting the Ionization flow.

The ionisation flow of the burner can be read off via the Service Programme of the control unit. Consult the Atmos Multi Service Manual for the access procedure for the Service Programme. The ionisation flow should be greater than 30 for both the low and high positions. If there are differences the ionisation probe must be examined and replaced as necessary (see Section 11.4).

7. Inspecting the air inlet filter.

The air inlet filter situated on the appliance's combustion air inlet must be inspected for damage and cleaned or replaced where necessary.

8. Inspecting the siphon.

Remove the siphon cap at the bottom of the appliance and check the cap for the presence of aluminium oxide.. If a quantity of aluminium oxide is present, the heat exchanger will require cleaning (see Section 5.2). The siphon cap must be firmly replaced following inspection.

10.2 Auxiliary equipment inspection.

The annual inspection of the boiler's auxiliary equipment comprises of checking the following:

1. Operation of safety relief valves
2. Operation of pressure reducing valve
3. Expansion vessels pre-charge

1. Safety relief valves.

Three safety relief valves are fitted to the system, two are external to the boiler and one internal. The valves operation may be checked by rotating the cap of the valve through 90°, which will result in a discharge of water from the valve. If there is no discharge, check that the system is correctly pressurised, if so replace the defective valve. Check that there is no discharge leak when the valves are returned to their closed position.

2. Pressure reducing valve

Turn off the cold water supply and remove the pressure reducing valve's head from the UV3 manifold. Check the gauze filter and clean or replace as necessary.

Check the water pressure at the valve outlet is no higher than 3.5bar. If the pressure is higher than 3.5bar then recalibrate or replace the valve as necessary.

3. Expansion vessels

□ Domestic hot water vessel. (Blue)

Turn off the mains cold water supply stop tap and depressurise the hot water system. Apply a suitable air pressure gauge to the vessels air valve. The pressure should be 3.5bar. If below 3.5bar the vessel must be re-pressurised or replaced.

❑ Heating system vessel (Red)

Isolate the boiler and depressurise the heating system. Follow the procedure for the domestic hot water vessel ensuring the pre charge pressure is as stated on the expansion vessel label. (Normally 1.5 bar)

10.3 .Servicing the boiler.

Warning! Before servicing the boiler, isolate the electrical supply and close the boiler's gas service control tap. Allow the boiler to cool before commencing work.

Gas soundness checks must always be carried out following servicing of any gas-carrying component.

Following servicing work, electrical system safety checks must always be undertaken using a suitable instrument prior to reinstating the electrical supply to the appliance.

Correct boiler servicing comprises of the following:

1. Cleaning the appliance outlet casting.
2. Inspecting the burner unit.
3. Cleaning the heat exchanger.
4. Inspect air supply/flue gas discharge system.
5. Unvented hot water tank inspection.

1. Cleaning the outlet casting

Using a 8mm socket, release the 3 fixing nuts securing the outlet casting to the base of the heat exchanger and remove the casting by gently separating it from the push fit connection with the condensate trap. (fig 31)

Remove the flue baffle by turning its base locking 'T' bar through 90°.

Inspect the outlet casting and baffle, cleaning where necessary.

Figure 31: Outlet casting

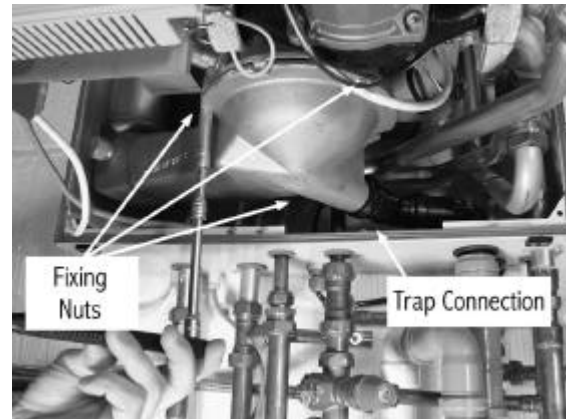
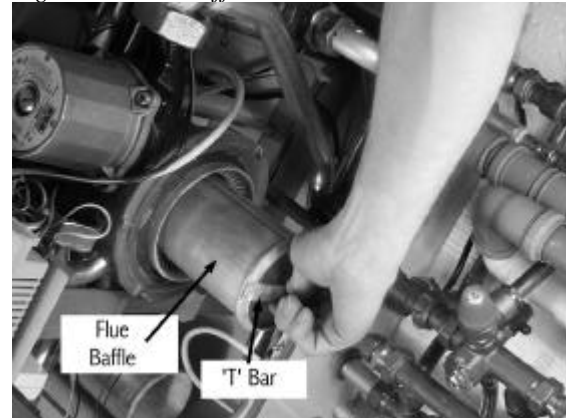

Figure 32: Flue baffle



2. Inspecting the burner unit

Disconnect the gas supply from the gas valve via the connecting joint union and release the 3 fixing nuts securing the burner to the inlet casting, using an 8mm socket. (fig 33)

Disconnect the push on electrical connections to the fan, high temperature thermostat, ignition electrode and ionisation electrode.

Figure 33: Removing burner assembly.

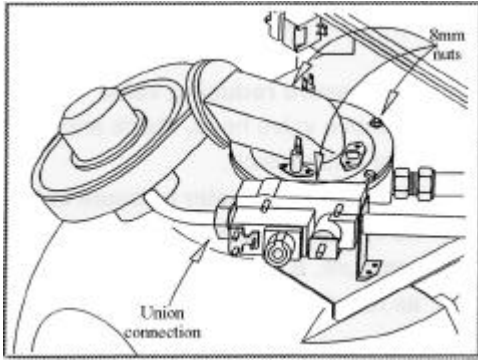

Lift and remove the burner assembly from the appliance.

Inspect the ignition electrode and check the electrode's distances between the burner and earth pin are 5mm and 3.5mm respectively. (fig 34). Replace or adjust the electrode as necessary

Inspect the ionisation electrode and check the distance between the electrode and the burner is 10mm. Replace or adjust the electrode as necessary

Figure 34: Ignition electrode.

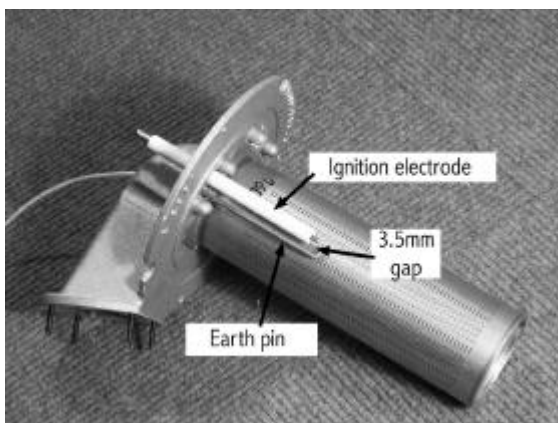

Inspect the fan and the inner grating of the burner and clean where necessary using a soft brush or compressed air.

Inspect the inlet casting sealing gasket and replace if necessary. (fig 35)

Figure 35: Inlet casting seal



3. Cleaning the heat exchanger.

Inspect the heat exchanger from the topside of the appliance and remove any deposits from the heat exchanger and fins using a soft brush.

Important!

The heat exchanger must be cleaned on at least every third service inspection.

Do not use a brush with metallic bristles, as this will damage the heat exchanger.

A purpose made heat exchanger cleaning brush (article number 93.98.12.410) is available on request from Atmos Heating Systems.

Re-assemble the boiler, fitting the burner assembly, flue baffle and outlet casting in reverse order to dismantling. Ensure all components are correctly sealed and located.

4. Inspection of air/flue gas discharge system.

Inspect the air supply /flue discharge system throughout its entirety ensuring that it is in sound condition with no damage to the pipework or joints.

Inspect the terminals and their position ensuring they are clear and unobstructed, taking remedial action where necessary.

5. Unvented hot water tank inspection.

Remove the hot water tank's insulation shell ensuring it is intact and free from damage replace if necessary.

Visually examine the domestic hot water tank for

signs of damage or water leaks, taking remedial action where necessary.

10.4. Completion of inspection and servicing.

On completion of the annual inspection and service the boiler must be checked for correct operation and all controls returned to their original settings, as found.

Where applicable check the Sentinel X100 inhibitor concentration level within the system water, topping up when necessary.

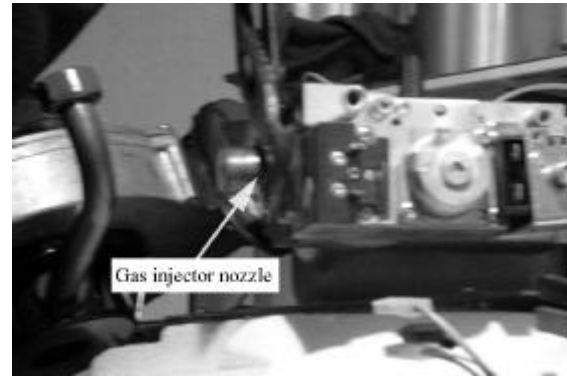

Figure 38

11. Component Replacement.

Warning! When replacing components, isolate the electrical supply and close the boiler's gas service control tap. Allow the boiler to cool before commencing work.

The replacement of the following components does not require draining of the boiler.

11.1 Gas Valve.

Disconnect the gas supply from the gas valve to the burner assembly via the connecting joint union and remove the valves 'Push' on electrical connections. (fig 36)

Unscrew and remove the gas injector nozzle from the gas valve assembly. (fig 37)

Release the valves four fixing bracket retaining bolts using an 8mm spanner and remove gas valve. (fig 38) Fit replacement gas valve in reverse order.

Figure 36

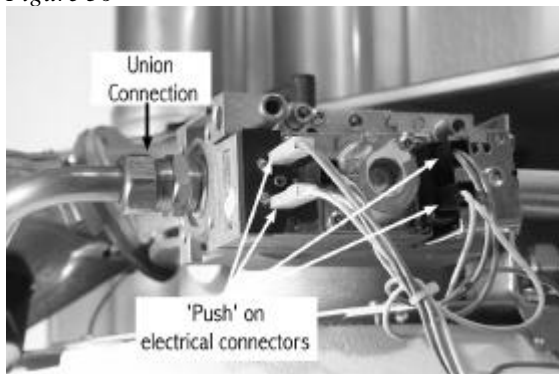
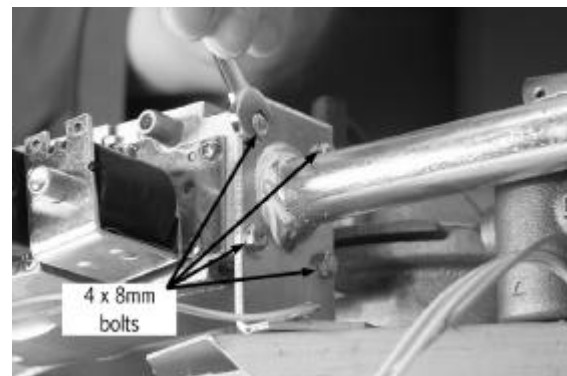

Figure 37



Reinstate boiler operation and check gas valve settings (Refer to section 10.1)

11.2 Fan

Disconnect the gas supply from the gas valve to the fan via the connecting joint union. (fig 36) and remove gas supply tube from the fan inlet connection.

Release the four nuts securing the fan to the burner manifold using a 7mm socket. (fig 39)

Fit replacement fan in reverse order.

Figure 39.

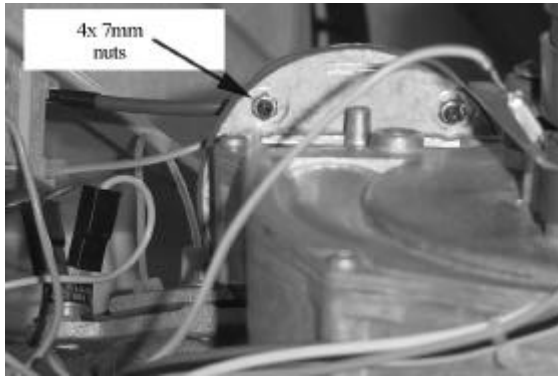

11.3 Ignition transformer.

Disconnect the 'push' on electrical connections and release the transformers two cross-headed fixing screws. (fig 40)

Fit new transformer in reverse order ensuring correct connection of the power supply to terminals 1 & 2 and ignition out from terminals 3 & 4.

Warning! Incorrect connection to the transformer terminals will result in blowing the boiler control unit.

Figure 40

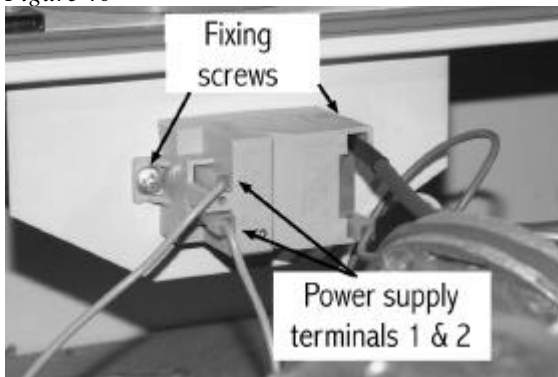

11.4 Burner, Ignition electrode, Ionisation electrode and Sight glass.

Disconnect and remove the boiler burner assembly (Refer to section 10.3)

❑ **Burner.** Detach the burner from the manifold by releasing the three fixing nuts using an 8mm socket. (fig 41). Fit the new burner in reverse order replacing the burner manifold gasket.

❑ **Ignition electrode.** Detach the ignition electrode from burner manifold by releasing the two cross-headed fixing screws. (fig 41) Fit the new electrode in reverse order checking that the electrode's

distances between the burner and earth pin are 5mm and 3.5mm respectively.

❑ **Ionisation electrode.** Detach the ionisation electrode from burner manifold by releasing the two cross-headed fixing screws. (fig 41) Fit new electrode in reverse order checking that a 10mm gap exists between the electrode and burner.

❑ **Sight glass.** Detach the sight glass from burner manifold by releasing the two cross-headed fixing screws. (fig 41) Fit new sight glass in reverse order replacing the sealing gasket.

Figure 41

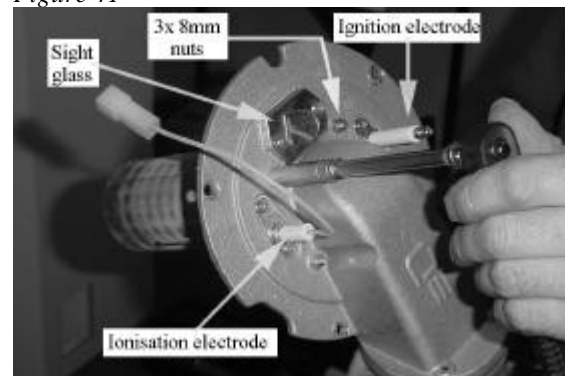

11.5 High limit thermostat.

Disconnect the thermostat's 'push' on electrical connections and unscrew the thermostat from its fitting using a 17mm socket (fig 42).

Fit replacement thermostat in reverse order.

Figure 42.

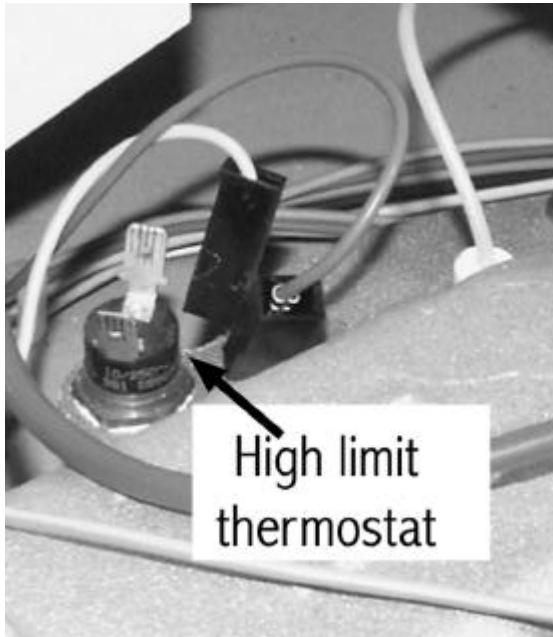

11.6 Pressure sensor.

Disconnect the pressure sensor 'push' on electrical connections and gently unscrew from its fitting by hand. (fig 43).

Fit replacement pressure sensor in reverse order.

Figure 43

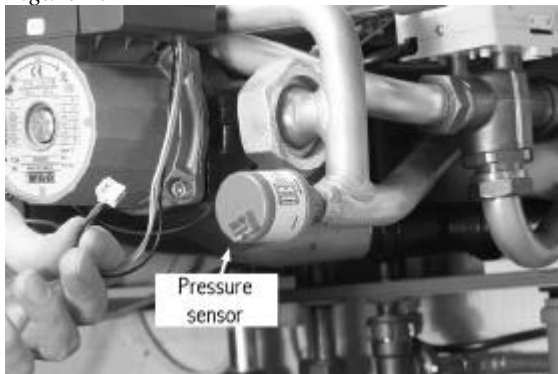

11.7 Hot water temperature sensor.

Disconnect the sensor's electrical connections and unscrew the hot water temperature sensor from its fitting using an 8mm spanner .(fig 44).

Fit the replacement sensor in reverse order.

Figure 44

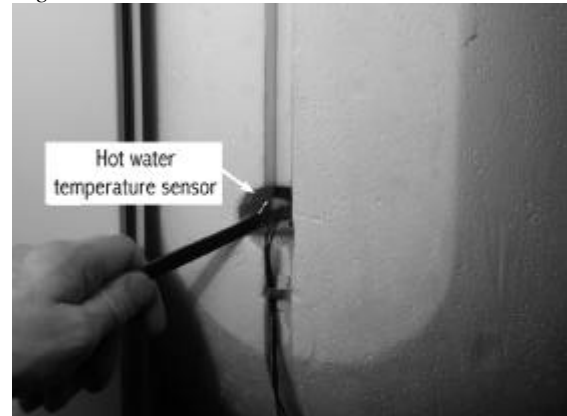

11.8 Control Unit.

Disconnect the electrical supply cable to the boiler from the mains isolation switch.

Remove the boiler components 'plug' in electrical connections from the control unit (fig 46) and remove control panel by gently pulling it forwards.

Fit replacement control panel in reverse order checking that correct polarity is maintained on connection to the mains isolation switch.

Note! The replacement of the following components requires the boiler to be drained.

For draining the boiler refer to section 9.3 and section 8.1 for re-filling the boiler.

11.9 Pump head.

Disconnect the electrical connections from the pump terminal block. (fig 45).

Release the two bolts securing the pump head using a 5mm-hexagon key. and remove the pump head from the pump body.

Fit replacement pump head in reverse order. The pump must be vented via its vent plug on refilling of the boiler.

Figure 45

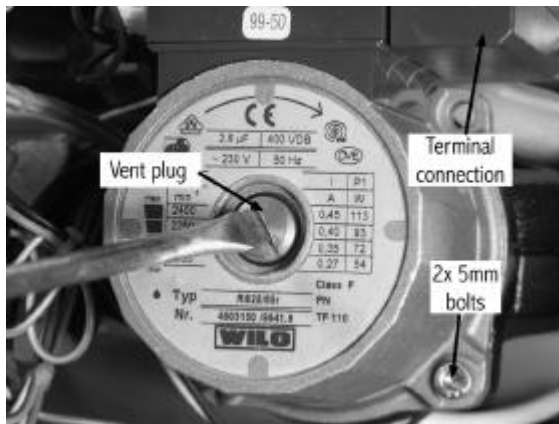

11.10. Three way valve.

Unplug the three-way valve's electrical connections from the boiler control unit (fig 46)

Disconnect the three compression pipe connections To the valve and remove valve. (fig 47)

Fit replacement three way valve in reverse order.

Figure 46

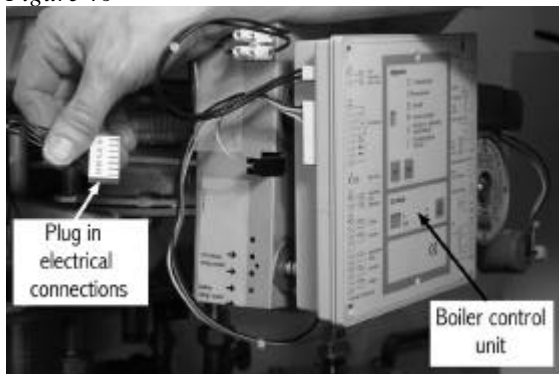
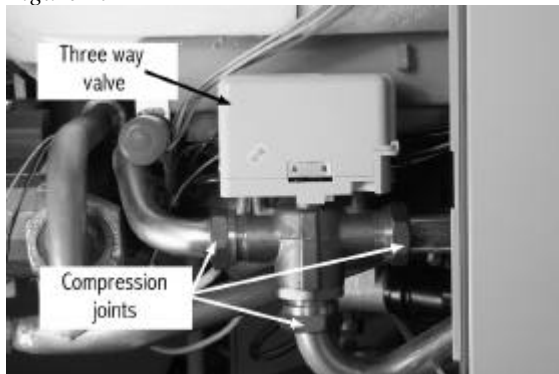

Figure 47



11.11 Heating water temperature sensor.

Disconnect the heating hot water temperature sensor electrical connections and unscrew the sensor from its fitting using a 15mm spanner (fig 48).

Fit the replacement sensor in reverse order.

Figure 48



11.12 Temperature & pressure relief valve.

Drain the domestic hot water system (refer to section 9.3)

Release the valve's outlet 22mm compression fitting to the discharge pipe. (fig 49)

Unscrew the temperature & pressure relief valve and remove.

Fit replacement valve in reverse order using a sealant suitable for potable water.

Figure 49

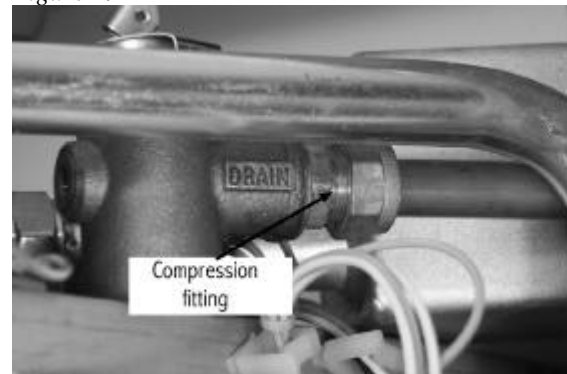

11.13. Hot water tank.

Disconnect and remove the following boiler components:

- Gas valve
- Fan/burner assembly
- High limit thermostat

- ❑ Temperature & pressure relief valve
- ❑ Boiler control unit
- ❑ Pump, and;
- ❑ Front section of insulation shell.

Disconnect the top water connection (fig 50) and bottom water connections to the tank. (fig 51 & 52)

Disconnect and remove the tank's top and bottom retaining brackets by releasing their fixing screws situated on both sides of the tank. (fig 53)

Remove hot water tank and fit replacement in reverse order.

Figure 50

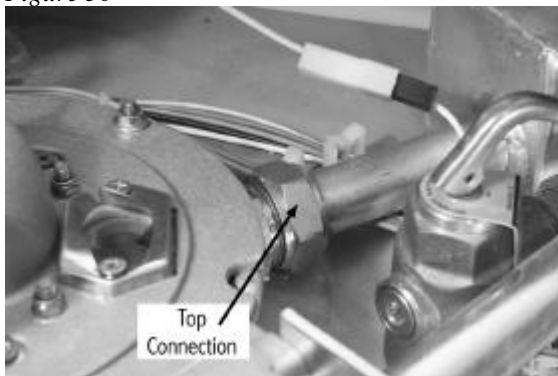

Figure 51

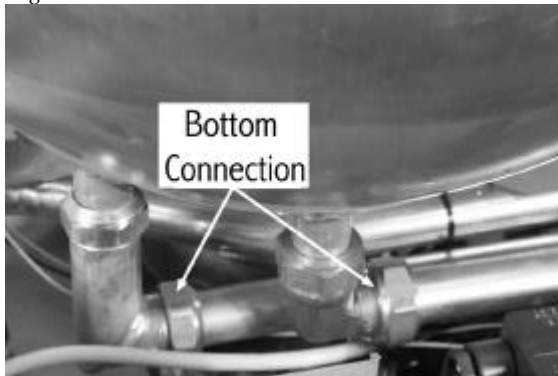

Figure 52

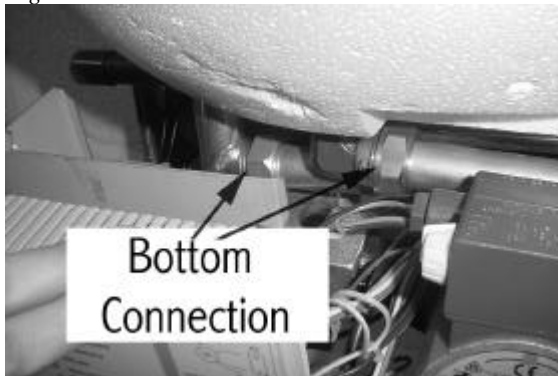
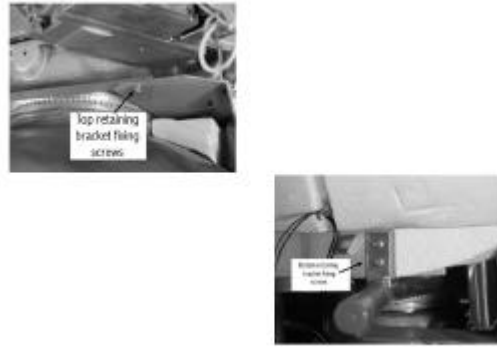

Figure 53



12. Malfunctions.

A malfunction can be caused by the failure of the central heating installation or appliance to function correctly.

The Atmos Multi has three types of malfunctions that can be reported via the diagnostic display, being.:

- Warning report
- Block report
- Malfunction report

❑ **Warning report.** A letter appearing on the diagnostic display for 1 second in every 5 identifies a warning report. The appliance continues to operate, but the function to which the report relates will be shut down or ignored. (fig 54)

Figure 54: Warning report

L	- Turn mains plug around
n	- Mains or reference voltage too low
F	- Mains frequency error
H	- Internal error
E	- Appliance type recognition error
C	- Central heating temperature sensor error*
* Simultaneously on the Central Heating water temperature display: HH sensor tripped/temperature > 118 °C LL sensor tripped/temperature < -10 °C.	

❑ **Block report.** A block is an error that occurs, but which does not cause the appliance to shut down. The appliance waits until the block has been resolved and then continues to operate normally. A permanently lit letter on the diagnostic display indicates a block. (fig 55)

Figure 55: Block report

8 b	- water heater sensor value incorrect (value < - 10 °C or > 118 °C)
8 c	- CH pressure incorrect, the capacity is limited to low capacity (value between -0.1 and 0.5 or 3 and 4 bars)
8 d	- CH return sensor incorrect (value < - 10 °C or > 118 °C)
8 h	- Outside sensor value incorrect (value < - 10 °C or > 118 °C).
8	is a status announcement

□ **Malfunction reports.** A malfunction is an error that occurs causing the appliance to be shut down by the control unit and locked. The appliance can only be unlocked by pressing the reset button. A flashing number or letter on the diagnostic display indicates a malfunction. (fig 56)

Figure 56: Malfunction report

2	- Fan (3) defective
3	- Incorrect ionisation (flame) signal
3	- No ionisation (flame) signal during start up procedure
4	- Ionisation signal absent during heat supply
4	- Ionisation signal remains present for too long after heat supply
6	- Gas valve control defective
7	- Insufficient flow of CH water during water heater heating
7	- Insufficient flow of CH water during home heating
8	- Maximum thermostat (10) cuts out and CH pressure is lower than 0.5 bars
9	- Maximum thermostat (10) cuts out and CH water temperature is lower than 80 °C.
9	- Safety malfunction regulating unit
Letter	- Internal malfunction regulating unit
No display	- No voltage

On resolving a malfunction press the reset button once. If the appliance does not unlock, press the reset button again after approximately 15 seconds. If the malfunction persists, consult the Atmos Multi Service Manual