

# ATAG Multipass PP Overpressure flue gas system Cascade



## Product list

- + Overpressure
- + Modulair PP elements
- + Compact built-in possibilities
- + Easy to use
- + Light in weight
- + Solutions for different kinds of cascade systems
- + Suitable for open and room sealed systems
- + Saves cost
- + Exclusive for ATAG Boilers (51 and 60kW)

# Multipass General

## Systems

ATAG supplies basic systems for cascade installations. The discharge can be positioned on the left as well as on the right side of the cascade.

Every basic set contains all boiler collectors and the end hood with condensate drain. The system can be added to as needed. In the overview we assumed a vertical length of 4.5 meters. This length should be mentioned when ordering so that the length is that what you need. With other lengths(see table) and/or if you discharge through a chimney the needed parts have to be chosen at the table "Parts PP Overpressure flue gas system".

### Open boilers

This flue gas system is for a cascade of boilers in a sufficient vented boiler room. The mentioned system examples are including air intake filters.

### Room sealed boilers

For room sealed systems one can use the same parts as for the air intake system as are used for the flue gas system. An overpressure discharge valve is not necessary in the air intake system.

The connection for the flue gas and air intake system can be made on the left as well as on the right side of the cascade.

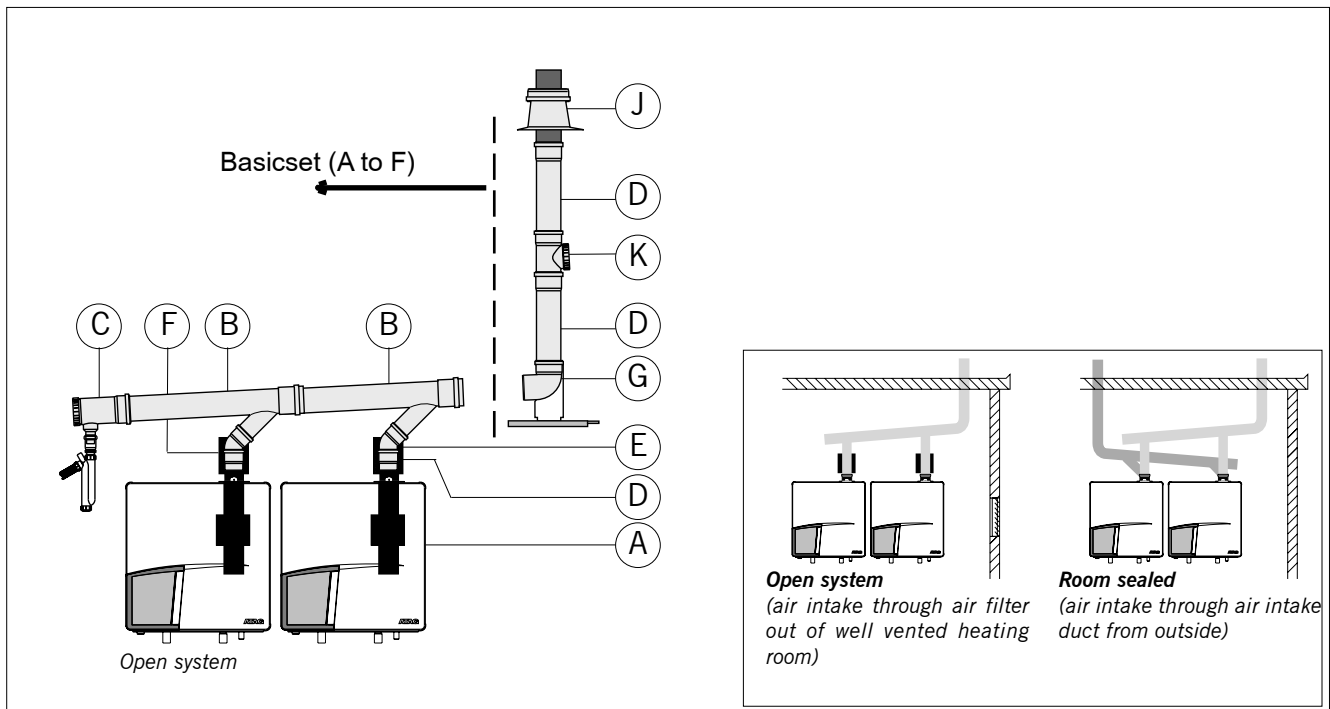

# Cascade System

number of boilers	A	B	C	D	E	F	G	H min.	I min.
2 x Q51S or Q60S	660	1360	1710	700	173	110	240	2065	700
3 x Q51S or Q60S	660	2060	1710	700	210	125	240	2165	700
4 x Q51S or Q60S	660	2760	1975	700	247	160	340	2355	700
5 x Q51S or Q60S	660	3460	1975	700	284	200	340	2655	700
6 x Q51S or Q60S	660	4160	1975	700	321	200	340	2655	700

*Dimensions Cascade System*

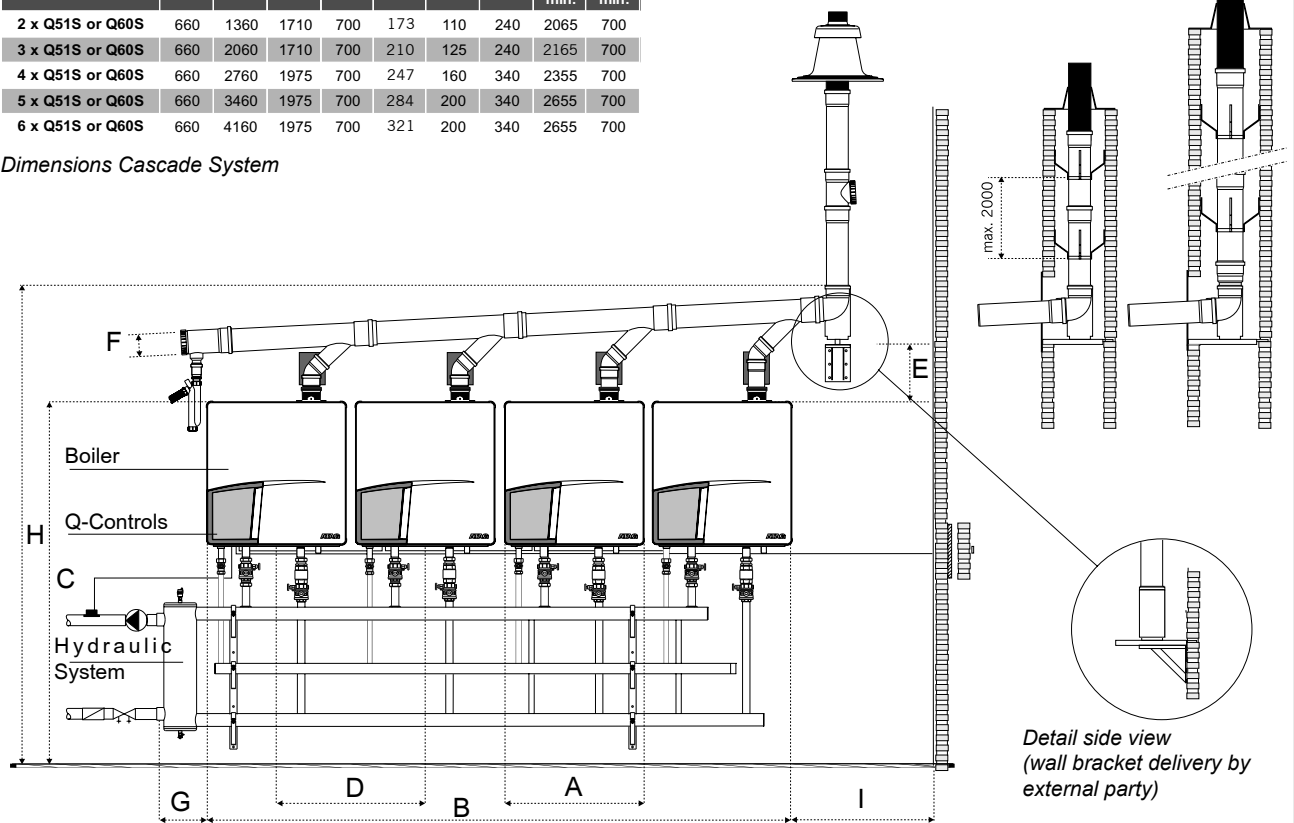

*Cascade system 4 x Q51S/Q60S boiler (dimensions in mm)*

**Cascade Total system** consists off:

**CV-boilers** (51 and 60 kW)

**Hydraulic system**

**PP Overpressure flue gas system**

**Q-Controls**

**CE** 0063BQ3021 Gastec CE-testdocument

**Important:**

- The ATAG PP Overpressure flue gas system is only suitable for the ATAG Q51S and the ATAG Q60S boilers.
- All components of the PP Overpressure flue gas system are provided with a CE-number. The CE-approval will be invalid, when there are parts used without a CE-number.

# Dimensionering

Onderstaande tabel toont de maximale afvoerlengte van 2 t/m 6 toestellen in cascade. Voor 2 t/m 4 toestellen in cascade is een grotere afvoerlengte te behalen door de diameter van het verticale afvoerkanaal te vergroten. Voor het toevoerkanaal bij gesloten opstelling moeten dezelfde waarden gehanteerd worden.

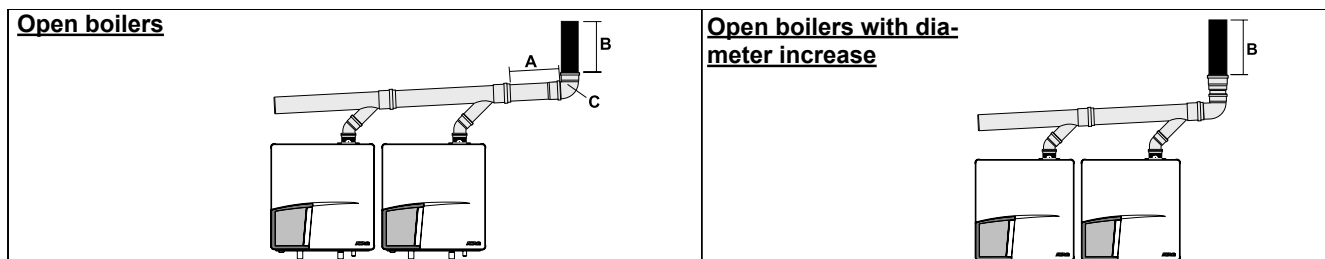

Open boilers								
Number of boilers	Collector diameter (mm)	Maximum length flue gas duct A+B+C	Reduction through the use of 1x 87° bend	Reduction through the use of 1x 45° bend	Increase diameter flue gas duct (mm)	Maximum length flue gas duct B	Reduction through the use of 1x 87° bend	Reduction through the use of 1x 45° bend
<b>Q60S</b>								
2	110	18	4	1	125	26*	5	2
3	125	14	5	2	160	28*	7	2
4	160	37	7	2	200	40*	3	2
5	200	40	3	2	x	x	x	x
6	200	40	3	2	x	x	x	x
<b>Q51S</b>								
2	110	26	4	1	125	40*	5	2
3	125	20	5	2	160	40*	7	2
4	160	40	7	2	200	40*	3	2
5	200	40	3	2	x	x	x	x
6	200	40	3	2	x	x	x	x

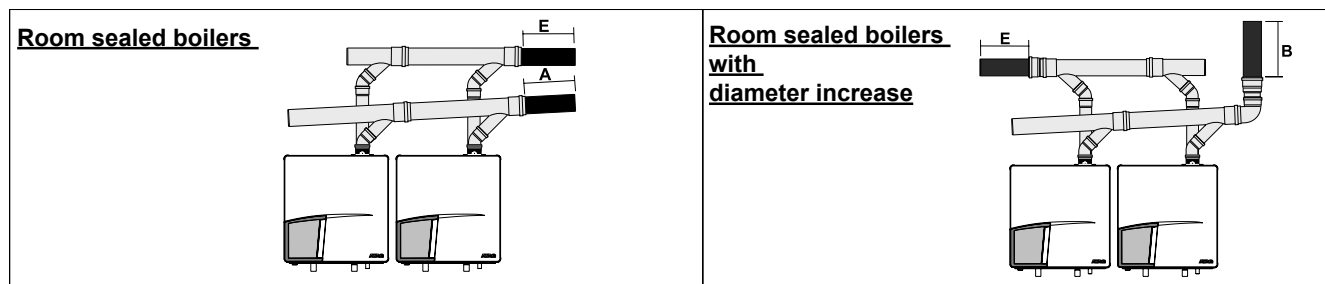

Room sealed boilers								
number of boilers	Collector diameter (mm)	Common length of flue gas and air intake duct A+E	Reduction through the use of 1x 87° bend	Reduction through the use of 1x 45° bend	Increase diameter flue gas duct (mm)	Common length of flue gas and air intake duct B+E	Reduction through the use of 1x 87° bend	Reduction through the use of 1x 45° bend
<b>Q60S</b>								
2	110	15	4	1	160	40*	7	2
3	125	10	5	2	200	34*	3	2
4	160	31	7	2	200	40*	3	2
5	200	40	3	2	x	x	x	x
6	200	40	3	2	x	x	x	x
<b>Q51S</b>								
2	110	23	4	1	125	33*	5	2
3	125	16	5	2	160	35*	7	2
4	160	40	7	2	200	40*	3	2
5	200	40	3	2	x	x	x	x
6	200	40	3	2	x	x	x	x

diameter- and length of flue gas duct (length and reductions in meters)

\* Bend and reducer directly mounted on collector.

table 2

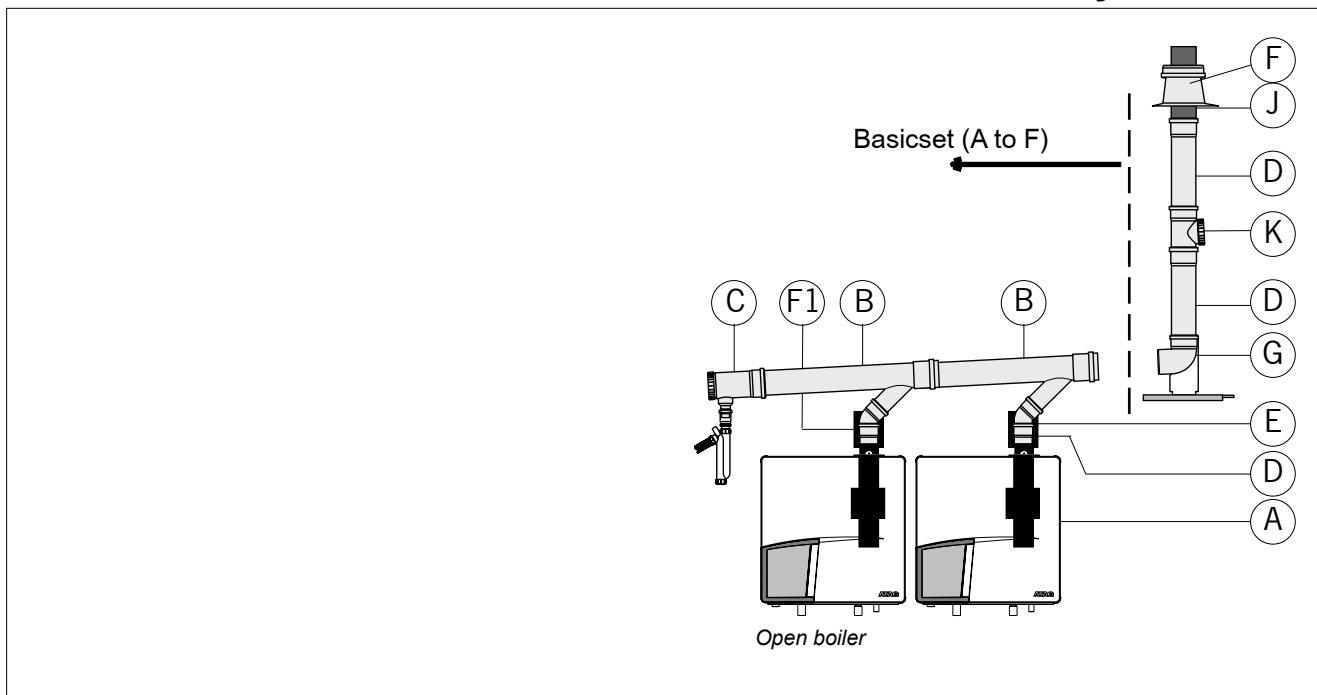

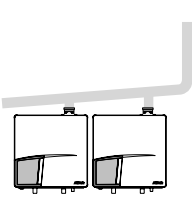
System	Pos.nr.	Description	Art.numb.	Nr
DCA2004U System for 2 boilers 	Basicset A to F		DCA2004U	
	A	1 Cascade over pressure valve $\varnothing$ 80	RO0800PU	2
	B	2 Collector PP $\varnothing$ 110/ $\varnothing$ 80,L=700	RC1170PU	2
	C	1 End Cover PP $\varnothing$ 110 with syphon	RE1100PU	1
	D	1 Pipe $\varnothing$ 80 X 250 mm	RP0803PU	2
	E	1 Elbow PP $\varnothing$ 80 X 45°	RB0845PU	2
	F	1 Air intake filter	DFL080KU	2
	Extension for vertical exhaust 4,5 mtr		order seperately	
	G	1 Chimney bend PP $\varnothing$ 110 x 87°	RS1187PU	1
	D	8 Pipe PP $\varnothing$ 110 mm x 2000 mm	RP1120PU	1
	D	7 Pipe PP $\varnothing$ 110 mm x 1000 mm	RP1110PU	2
	J	1 Discharge pipe PP UV $\varnothing$ 110	RU1100PU	1
	K	2 Chimney inspection piece PP 110	RI1100PU	1
	L	1 Distance holder $\varnothing$ 110 (PP 6x)	RA1100PU	2

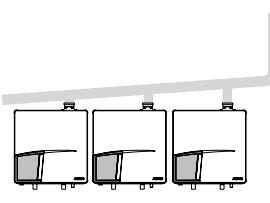
System	Pos.no.	Description	Art.numb.	numb-er.
DCA3004U System for 3 boilers 	Basicset A t/m F		DCA3004U	
	A	1 Cascade over pressure valve $\varnothing$ 80	RO0800PU	3
	B	4 Collector PP $\varnothing$ 125/ $\varnothing$ 80,L=700	RC1370PU	3
	C	2 End Cover PP $\varnothing$ 125 with syphon	RE1300PU	1
	D	1 Pipe $\varnothing$ 80 X 250 mm	RP0803PU	3
	E	1 Elbow PP $\varnothing$ 80 X 45°	RB0845PU	3
	F	1 Air intake filter	DFL080KU	3
	Extension for vertical exhaust 4,5 mtr		order seperately	
	G	1 Chimney bend PP $\varnothing$ 125x 87°	RS1387PU	1
	D	1 Pipe PP $\varnothing$ 125 mm x 2000 mm	RP1320PU	1
	D	2 Pipe PP $\varnothing$ 125 mm x 1000 mm	RP1310PU	2
	J	12 Discharge pipe PP UV $\varnothing$ 125	RU1300PU	1
	K	11 Chimney inspection piece PP 125	RI1300PU	1
	L	2 Distance holder $\varnothing$ 125 (PP 6x)	RA1300PU	2

### Installatievoorbeelden

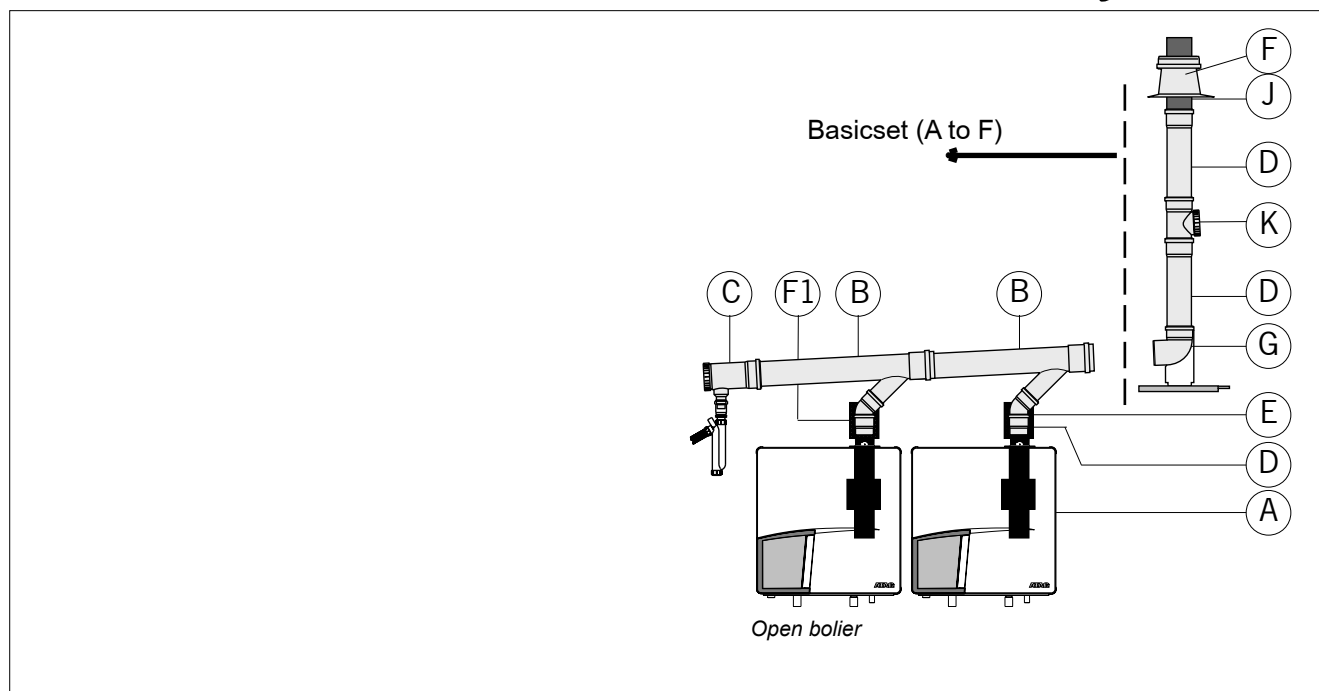

System	Pos.no.	Description	Art.num.	number
DCA4004U System for 4 boilers	Basicset A t/m F		DCA4004U	
	A	1 Cascade over pressure valve $\varnothing$ 80	RO0800PU	4
	B	6 Collector PP $\varnothing$ 160/ $\varnothing$ 80,L=700	RC1670PU	4
	C	3 End Cover PP $\varnothing$ 160 with syphon	RE1600PU	1
	D	1 Pipe PP $\varnothing$ 80 X 250 mm	RP0803PU	4
	E	1 Elbow PP $\varnothing$ 80 X 45°	RB0845PU	4
	F	1 Air intake filter	DFL080KU	4
	Extension for vertical exhaust 4,5 mtr		order seperately	
	G	3 Chimney bend PP $\varnothing$ 160x 87°	RS1687PU	1
	D	16 Pipe PP $\varnothing$ 160 mm x 2000 mm	RP1620PU	1
	D	15 Pipe PP $\varnothing$ 160 mm x 1000 mm	RP1610PU	2
	J	3 Discharge pipe PP UV $\varnothing$ 160	RU1600PU	1
	K	4 Chimney inspection piece PP 160	RI1600PU	1
	L	3 Distance holder $\varnothing$ 160 (PP 6x)	RA1600PU	2

System	Pos.no.	Description	Art.num.	Number
DCA5004U System for 5 boilers	Basicset A t/m F		DCA5004U	
	A	1 Cascade over pressure valve $\varnothing$ 80	RO0800PU	5
	B	8 Collector PP $\varnothing$ 200/ $\varnothing$ 80,L=700	RC2070PU	5
	C	4 End Cover PP $\varnothing$ 200 with syphon	RE2000PU	1
	D	1 Pipe PP $\varnothing$ 80 X 250 mm	RP0803PU	5
	E	1 Elbow PP $\varnothing$ 80 X 45°	RB0845PU	5
	F	1 Air intake filter	DFL080KU	5
	Extension for vertical exhaust 4,5 mtr		order seperately	
	G	4 Chimney bend PP $\varnothing$ 200x 87°	RS2087PU	1
	D	20 Pipe PP $\varnothing$ 200 mm x 2000 mm	RP2020PU	1
	D	19 Pipe PP $\varnothing$ 200 mm x 1000 mm	RP2010PU	2
	J	4 Discharge pipe PP UV $\varnothing$ 200	RU2000PU	1
	K	5 Chimney inspection piece PP 200	RI2000PU	1
	L	4 Distance holder $\varnothing$ 200 (PP 6x)	RA2000PU	2

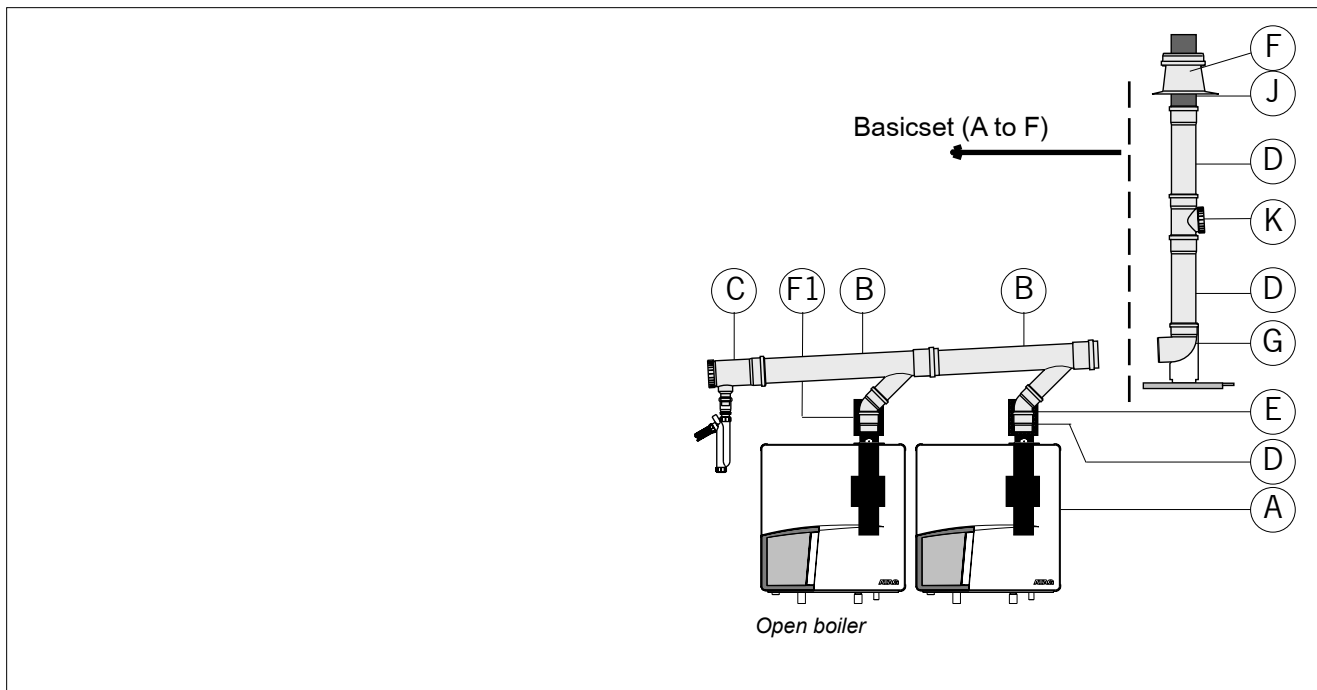

### Installatievoorbeelden



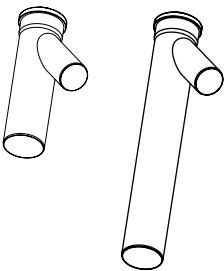

System	Pos.nr.	Description	Art.num.	Number
DCA6004U System for 6 boilers		Basicset A t/m F	DCA6004U	
	A	1 Cascade over pressure valve $\varnothing$ 80	RO0800PU	6
	B	8 Collector PP $\varnothing$ 200/ $\varnothing$ 80,L=700	RC2070PU	6
	C	4 End Cover PP $\varnothing$ 200 with syphon	RE2000PU	1
	D	1 Pipe $\varnothing$ 80 X 250 mm	RP0803PU	6
	E	1 Elbow PP $\varnothing$ 80 X 45°	RB0845PU	6
	F	1 Air intake filter	DFL080KU	6
		Extension for vertical exhaust 4,5 mtr	order seperately	
	G	4 Chimney bend PP $\varnothing$ 200x 87°	RS2087PU	1
	D	20 Pipe PP $\varnothing$ 200 mm x 2000 mm	RP2020PU	1
	D	19 Pipe PP $\varnothing$ 200 mm x 1000 mm	RP2010PU	2
	J	4 Discharge pipe PP UV $\varnothing$ 200	RU2000PU	1
	K	5 Chimney inspection piece PP 200	RI2000PU	1
	L	4 Distance holder $\varnothing$ 200 (PP 6x)	RA2000PU	2

System	Pos.nr.	Description	Art.num.	Number
DCA4004U System for 4 boilers		Basisset A to F	DCA4004U	
Birds eye view of 4 boilers in cascade. Mounted back to back	A	1 Cascade over pressure valve $\varnothing$ 80	RO0800PU	4
	B	5 Collector PP $\varnothing$ 160/ $\varnothing$ 80,L=350	RC1670PU	3
	B	6 Collector PP $\varnothing$ 160/ $\varnothing$ 80,L=700	RC1670PU	1
	C	1 End Cover PP $\varnothing$ 160 with syphon	RE1600PU	1
	D	1 Pipe $\varnothing$ 80 X 250 mm	RP0803PU	4
	D	2 Pipe $\varnothing$ 80 X 500 mm	RP0803PU	4
	E	1 Elbow PP $\varnothing$ 80 X 45°	RB0845PU	4
	F	1 Air intake filter	DFL080KU	4
		Extension for vertical exhaust 4,5 mtr	order seperately	
	G	1 Chimney bend PP $\varnothing$ 160x 87°	RS1687PU	1
	D	8 Pipe PP $\varnothing$ 160 mm x 2000 mm	RP1620PU	1
	D	7 Pipe PP $\varnothing$ 160 mm x 1000 mm	RP1610PU	2
	J	1 Discharge pipe PP UV $\varnothing$ 160	RU1600PU	1
	K	2 Chimney inspection piece PP 160	RI1600PU	1
	L	1 Distance holder $\varnothing$ 160 (PP 6x)	RA1600PU	2

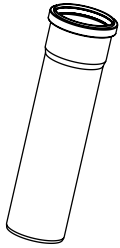
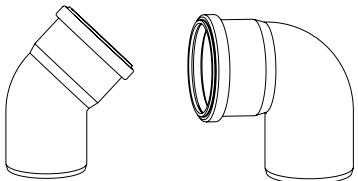
Enclosed example is a cascade in which the boilers are mounted back to back. Here also standard plastic flue gas parts can be used.

	Pos.nr.	Description	Art. Number
	<b>A</b>	<b>Boiler flue gas pipe</b>	
	1	Cascade over pressure valve ø 80	RO0800PU
	<b>B</b>	<b>Collector modules</b>	
	1	<b>Collector PP ø 110 / ø 80, L=350</b>	RC1135PU
	2	Collector PP ø 110 / ø 80, L=700	RC1170PU
	3	Collector PP ø 125 / ø 80, L=350	RC1335PU
	4	Collector PP ø 125 / ø 80, L=700	RC1370PU
	5	Collector PP ø 160 / ø 80, L=350	RC1635PU
	6	Collector PP ø 160 / ø 80, L=700	RC1670PU
	7	Collector PP ø 200 / ø 80, L=350	RC2035PU
8	Collector PP ø 200 / ø 80, L=700	RC2070PU	
	<b>C</b>	<b>End Cover with syphon</b>	
	1	End Cover PP ø 110 with syphon	RE1100PU
	2	End Cover PP ø 125 with syphon	RE1300PU
	3	End Cover PP ø 160 with syphon	RE1600PU
4	End Cover PP ø 200 with syphon	RE2000PU	
	<b>D</b>	<b>Pipe</b>	
	1	Pipe PP ø 80 X 250 mm	RP0803PU
	2	Pipe PP ø 80 X 500 mm	RP0805PU
	3	Pipe PP ø 80 X 1000 mm	RP0810PU
	4	Pipe PP ø 80 X 2000 mm	RP0820PU
	5	Pipe PP ø 110 X 250 mm	RP1103PU
	6	Pipe PP ø 110 X 500 mm	RO1105PU
	7	Pipe PP ø 110 X 1000 mm	RP1110PU
	8	Pipe PP ø 110 X 2000 mm	RP1120PU
	9	Pipe PP ø 125 X 250 mm	RP1303PU
	10	Pipe PP ø 125 X 500 mm	RP1305PU
	11	Pipe PP ø 125 X 1000 mm	RP1310PU
	12	Pipe PP ø 125 X 2000 mm	RP1320PU
	13	Pipe PP ø 160 X 250 mm	RP1603PU
	14	Pipe PP ø 160 X 500 mm	RP1605PU
	15	Pipe PP ø 160 X 1000 mm	RP1610PU
	16	Pipe PP ø 160 X 2000 mm	RP1620PU
	17	Pipe PP ø 200 X 250 mm	RP2003PU
	18	Pipe PP ø 200 X 500 mm	RP2005PU
	19	Pipe PP ø 200 X 1000 mm	RP2010PU
20	Pipe PP ø 200 X 2000 mm	RP2020PU	
	<b>E</b>	<b>Bends</b>	
	1	Bend PP ø 80 X 45°	RB0845PU
	2	Bend PP ø 80 X 87°	RB0887PU
	3	Bend PP ø 110 X 45°	RB1145PU
	4	Bend PP ø 110 X 87°	RB1187PU
	5	Bend PP ø 125 X 45°	RB1345PU
	6	Bend PP ø 125 X 87°	RB1387PU
	7	Bend PP ø 160 X 45°	RB1645PU
	8	Bend PP ø 160 X 87°	RB1687PU
	9	Bend PP ø 200 X 45°	RB2045PU
10	Bend PP ø 200 X 87°	RB2087PU	

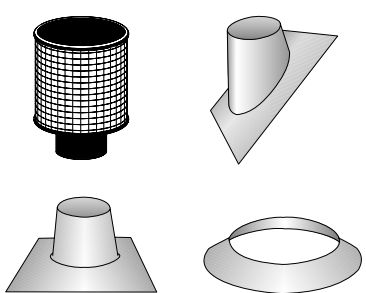
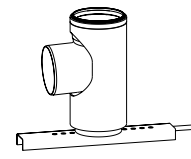
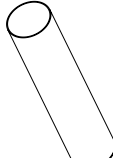
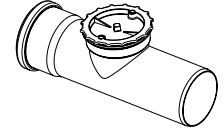
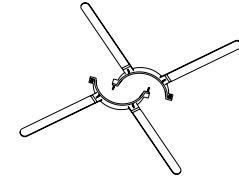

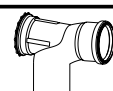
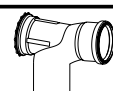
	Pos. nr.	Description	Art.numb.
	<b>F</b>	<b>Accessories</b>	
	1	Air filter	DFL080KU
	2	Flat roof sealing plate $\varnothing$ 110 X 45°	DD4510SU
	3	Flat roof sealing plate $\varnothing$ 163 X 45°	DD4516SU
	4	Flat roof sealing plate $\varnothing$ 203 X 45°	DD4520SU
	5	Flat roof sealing plate $\varnothing$ 110 X 90°	DD9010SU
	6	Flat roof sealing plate $\varnothing$ 163 X 90°	DD9016SU
	7	Flat roof sealing plate $\varnothing$ 203 X 90°	DD9020SU
	8	Rain brim for roof slate $\varnothing$ 110 mm	DRR010SU
	9	Rain brim for roof slate $\varnothing$ 163 mm	DRR016SU
10	Rain brim for roof slate $\varnothing$ 203 mm	DRR020SU	
	<b>G</b>	<b>Chimney bend</b>	
	1	Chimney bend PP $\varnothing$ 110 X 87°	RS1187PU
	2	Chimney bend PP $\varnothing$ 125 X 87°	RS1387PU
	3	Chimney bend PP $\varnothing$ 160 X 87°	RS1687PU
4	Chimney bend PP $\varnothing$ 200 X 87°	RS2087PU	
	<b>J</b>	<b>Exhaust pipe</b>	
	1	Exhaust pipe PP UV $\varnothing$ 110	RU1100PU
	2	Exhaust pipe PP UV $\varnothing$ 125	RU1300PU
	3	Exhaust pipe PP UV $\varnothing$ 160	RU1600PU
4	Exhaust pipe PP UV $\varnothing$ 200	RU2000PU	
	<b>K</b>	<b>Chimney inspection piece</b>	
	1	Chimney inspection piece PP $\varnothing$ 80	
	2	Chimney inspection piece PP $\varnothing$ 110	RI1100PU
	3	Chimney inspection piece PP $\varnothing$ 125	RI1300PU
	4	Chimney inspection piece PP $\varnothing$ 160	RI1600PU
5	Chimney inspection piece PP $\varnothing$ 200	RI2000PU	
	<b>L</b>	<b>Distance holder</b>	
	1	Distance holder $\varnothing$ 110 (PP 6x)	RA1100PU
	2	Distance holder $\varnothing$ 125 (PE 6x)	RA1300PU
	3	Distance holder $\varnothing$ 160 (PE 6x)	RA1600PU
4	Distance holder $\varnothing$ 200 (SS 6x)	RA2000RU	
	<b>M</b>	<b>End cover</b>	
	1	End cover PP $\varnothing$ 110	RD1100PU
	2	End cover PP $\varnothing$ 125	RD1300PU
	3	End cover PP $\varnothing$ 160	RD1600PU
4	End cover PP $\varnothing$ 200	RD2000PU	
	<b>N</b>	<b>Reducer</b>	
	1	Reducer PP $\varnothing$ 110 / $\varnothing$ 125 M	RV1113PU
	2	Reducer PP $\varnothing$ 125 / $\varnothing$ 160 M	RV1316PU
3	Reducer PP $\varnothing$ 160 / $\varnothing$ 200 M	RV1620PU	
	<b>P</b>	<b>Wall terminal</b>	
		Wall terminal $\varnothing$ 110 / $\varnothing$ 160	
		Wall terminal $\varnothing$ 125 / $\varnothing$ 185	
		Wall terminal $\varnothing$ 160 / $\varnothing$ 225	
	Wall terminal $\varnothing$ 200 / $\varnothing$ 300		
	<b>Q</b>	<b>Boiler inspection piece</b>	
		boiler inspection piece PP $\varnothing$ 80 x 87°	RT0887PU

# Ingenious Flues



A unique feature of this system is the overpressure non-return valve that is put into every Cascade boiler. This replaces the standard plastic flue pipe and incorporates a built-in siphon connected to the boiler's common siphon for condensate drainage. The way this operates is very simple. When the boiler is off, the valve is closed, preventing potential wind pressure reaching the boiler and avoiding re-circulation of flue gasses where multiple boilers are connected to a common flue gas duct.

The two-stage operation of the valve keeps resistance very low and even on low load, the boiler fan pushes the valve open completely. When the valve is closed, condensate from the common flue gas duct is diverted via the built-in siphon to the common boiler siphon.

## Unique Selling Points:

- + **Overpressure**
- + **Modulair PP elements**
- + **Compact built-in possibilities**
- + **Easy to use**
- + **Light in weight**
- + **Solutions for different kinds of cascade systems**
- + **Suitable for open and room sealed systems**
- + **Saves cost**
- + **Exclusive for ATAG Boilers (51 and 60kW)**



**ATAG**  
Heating

• ATAG Heating UK Ltd. • Unit 3 • Beaver Trade Park • Quarry Lane • Chichester • West Sussex • PO19 8NY •  
• Phone: 01243 815 770 • Fax: 0124 839 596 • info@atagheating.co.uk • www.atagheating.co.uk •

• Total Energy Management Ltd. • Unit 9 • Ballybritt Industrial Estate • Monivea Road • Galway • Ireland •  
• (091) 769174 • (091) 769485 • info@tem.ie • www.tem.ie •