

Gas Fired Storage Water Heaters

**Installation guide, operation
and service manual**

Propane and Butane

HI-FLO RANGE

Models L32/143, L65/169, L81/251, L62/309, L54/399,
Permanent Pilot, Piezo Ignition 'E'/'F' Series

STANDARD RANGE

Models L24/31, L32/35, L40/36, L63/71, L84/74
Permanent Pilot, Auto Ignition 'G' Series



Working towards
a cleaner future





Reproduction of any information in this publication by any method is not permitted unless prior written approval has been obtained from Andrews Water Heaters.

Andrews Storage Water Heaters have been designed and manufactured to comply with current International standards of safety. In the interests of the health and safety of personnel and the continued safe, reliable operation of the equipment, safe working practices must be employed at all times. The attention of U.K. users is drawn to their responsibilities under the Health and Safety Regulations 1993.

All installation and service on the Andrews Water Heater must be carried out by properly qualified personnel, and therefore no liability can be accepted for any damage or malfunction caused as a result of intervention by unauthorised personnel.

The Andrews Water Heaters policy is one of continuous product improvement, and therefore the information in this manual, whilst completely up to date at the time of publication, may be subject to revision without prior notice.

Further information and assistance can be obtained from:

Andrews Water Heaters

Wood Lane, Erdington, Birmingham B24 9QP

Tel: 0845 070 1055 Fax: 0845 070 1059

Sales: 0845 070 1056

Technical: 0845 070 1057

Service: 0845 070 1058

Email: andrews@andrews-waterheaters.co.uk

www.andrewswaterheaters.co.uk

**THE ANDREWS WATER HEATERS COVERED IN THIS MANUAL
ARE FOR USE WITH PROPANE AND BUTANE GASES ONLY**

SECTION 1	GENERAL AND SAFETY INFORMATION	
	General Information	2
	British Standards	2
	Health and Safety Regulations 1993	3
	Effectiveness in Combating Legionellae	3
SECTION 2	TECHNICAL DATA	
	Standard Range	4
	Hi-Flo Range	5
SECTION 3	INSTALLATION	
	Introduction	6
	Assembling the Draught Diverter	6
	Location	6
	Gas Supply	7
	Installation of LPG Supply	8
	Electrical Supply - Auto Ignition - Standard Range	10
	Flue Systems	11
	Air Supply and Ventilation	13
	Water Quality and Treatment	14
	Water Connections - Hydrojet System	15
	Vented Systems, Standard Range	16
	Unvented Systems, Standard Range	18
	Vented Systems, Hi-Flo Range	20
	Unvented Systems, Hi-Flo Range	23
SECTION 4	COMMISSIONING	
	Standard Range - Permanent Pilot Models	26
	Hi-Flo Range - Permanent Pilot Models	28
	Standard Range - Auto Ignition	30
SECTION 5	OPERATION	
	Standard Range - Auto Ignition	33
	Hi-Flo Range	33
SECTION 6	SERVICING	
	Introduction	34
	Pre-Service Operations	34
	Burner Assembly, Standard Range	34
	Burner Assembly, Hi Flo Range	35
	Gas Control Valve, Standard Range	35
	Gas Control Valve, Hi Flo Range	35
	Flue Ways	36
	Cleaning the Storage Vessel	36
	Magnesium Anode(s)	37
	Safety Valve	37
	Re-start	37
SECTION 7	REPLACING COMPONENTS, Hi-Flo RANGE	
	Gas Control Valve	38
	User-Adjustable Control Thermostat	38
	Thermopile/Pilot Burner/Pilot Restrictor	39
	Burner	39
SECTION 8	FAULT FINDING	40
SECTION 9	PARTS LISTS AND ILLUSTRATIONS	
	Standard Range	44
	Hi Flo Range L32/143, L65/169, L81/251	46
	Hi Flo Range L62/309, L54/399	48
	Unvented Systems Kit	49
	24v Auto System Kit	52

GENERAL INFORMATION

The Andrews Water Heater has been designed for use with PROPANE or BUTANE GAS only and is manufactured to give an efficient, reliable and long service life.

To ensure the continued, trouble-free operation of your heater at maximum efficiency, it is essential that correct installation, commissioning, operation and service procedures are carried out strictly in accordance with the instructions given in this manual. By law, installation and commissioning of the heater must be carried out by properly qualified personnel.

The heater(s) must be installed in accordance with the following requirements;
The current GAS SAFETY (INSTALLATION AND USE) REGULATIONS
The current BUILDING REGULATIONS
The Water Supply (WATER FITTINGS) REGULATIONS 1999

Additionally, installation should be performed in accordance with all relevant requirements of the Gas Supplier, Local Authority and recommendations of the British Standards and Codes of Practice detailed below.

BRITISH STANDARDS AND CODES OF PRACTICE

STANDARD RANGE

BS 6700: 1997	Specification for design, installation, testing and maintenance of services supplying water for domestic use within buildings and their curtilages. This standard supersedes the following British Standards and Codes of Practice: CP99, CP310, CP324, 202, CP342 Part 2, Centralised Hot Water Supply.
BS 5440	Installation of flues and ventilation for gas appliances of rated output not exceeding 60kW.
Part 1:2000	Specification for installation of flues.
Part 2:1989	Specification for installation of ventilation for gas appliances.
BS 5546:1990	Installation of gas hot water supplies for domestic purposes.
BS 6891	Installation of low pressure gas pipework of up to 28mm in domestic premises.
BS 7206:1990	Specification for unvented hot water storage units and packages.
I/M2	Purging procedures for non-domestic gas installations.
I/M5	Soundness testing procedures for industrial and commercial gas installations.
I/M11	Flues for commercial and industrial gas fired boilers and air heaters.
I/M16	Notes on installation of gas pipework (excluding 25mm and below).

Hi-Flø RANGE

As STANDARD RANGE plus:

BS 6644: Installation of gas fired hot water boilers of rated inputs between 60kW and 2MW.

IGE/UP/10 Pt.1
Edition 2

Installation of Gas Appliances in Industrial and Commercial Premises

NOTE:

Consideration should be given to amendments or updates to the above standards.

It is the duty of manufacturers and suppliers of products for use at work to ensure, so far as is practicable, that such products are safe and without risk to health when properly used and to make available to users, adequate information about their safe and proper operation.

Andrews Water Heaters should only be used in the manner and purpose for which they were intended and in accordance with the instructions in this manual. Although the heaters have been manufactured with paramount consideration to safety, certain basic precautions specified in this manual must be taken by the user.

It is imperative that all users of the heater must be provided with all the information and instruction necessary to ensure correct and safe operation.

Water systems in buildings have been associated with outbreaks of Legionnaires' Disease, particularly in health care facilities where occupants are significantly more susceptible to infection.

In recognition of the risks in hospitals, a Code of Practice for the Control of Legionellae in Health Care premises has been issued by the Department of Health (1991). Codes of Practice applicable to other premises have been published by other organisations, principally the Health and Safety Executive (HS)(G70) and the Chartered Institute of Building Services Engineers (CIBSE, TM13).

All Codes of Practice draw attention to the design and operation of water systems with reference to avoidance of factors that favour colonisation by Legionellae bacteria. These factors include stagnation, lukewarm conditions (20°C to 45°C) and the accumulation of debris, scale and corrosion in the base of tanks and calorifiers.

Andrews Water Heaters has commissioned an independent evaluation of their products to investigate their resistance to build-up of legionellae bacteria.

Experiments were conducted to determine whether, following a substantial challenge by legionellae pneumophila, after overnight and stagnation conditions, the system was rendered free from viable recoverable legionellae. It was found that at 61°C, following a challenge of approximately 107 organisms per litre, within one hour, more than 99.999% of organisms had been killed. After a subsequent stagnation period, sampling did not reveal any residual contamination. The design of the base of the water heater precludes legionellae colonisation, even after build-up of debris. The burner positioning ensures that the water at the bottom of the heater reaches the same, or higher temperature as in the rest of the heater.

Based on data obtained through experiment, the Andrews Water Heater can be described as legionellae resistant as it is considered unlikely that, at the temperature tested, the organism would colonise the water heater and present a possible health risk.

HEALTH AND SAFETY REGULATIONS 1993

EFFECTIVENESS IN COMBATING LEGIONELLAE

SECTION 2

TECHNICAL DATA

STANDARD RANGE

ANDREWS MODEL NO.		L24/31	L32/35	L40/36	L63/71	L84/74
Storage Capacity	l gal	109 24	145 32	182 40	286 63	382 84
Recovery thro' 44°C/80°F	l/h gal/h	141 31	163 35	163 36	322 71	336 74
Recovery thro' 56°C/100°F	l/h gal/h	113 25	127 28	131 29	258 57	269 59
Heat Input Gross	kW Btu/h	9.5 32,414	11.0 37,532	11.0 37,532	22.0 75,064	22.0 75,064
Heat Input Net	kW Btu/h	8.6 29,343	10 34,120	10 34,120	20 68,240	20 68,240
Gas		LPG CAT I ₃				
Inlet Gas Pressure	Propane	mbar ins wg.	37 14.86	37 14.86	37 14.86	37 14.86
	Butane	mbar ins wg.	28 11.26	28 11.26	28 11.26	28 11.26
Gas Flow Rate	m ³ /h ft ³ /h	0.36 12.74	0.41 14.64	0.41 14.64	0.83 29.28	0.83 29.28
Gas Connection	Rc (in BSP Int)	1/2	1/2	1/2	1/2	1/2
Flue Gas Temp	°C	180	180	185	125	130
Flue Gas Volume	m ³ /h	16	16	23	28	34
Gas Injector Orifice Diameter	mm in	1.5 0.059	1.6 0.063	1.6 0.063	2.25 0.089	2.25 0.089
Flue Size (Secondary)	mm in	100 4	100 4	100 4	125 5	125 5
Cold Water Feed Connection	R (in BSP/Ext)	1	1	1	1	11/4
Hot Water Flow Connection	R (in BSP/Ext)	1	1	1	1	11/4
*Return Connection	Rp (in BSP/Int)	3/4	3/4	3/4	3/4	3/4
Drain Port Size	R (in BSP/Ext)	3/4	3/4	3/4	3/4	3/4
Max. Working Pressure	bar lbf/in ²	10 150	10 150	10 150	10 150	10 150
Max. Test Pressure	bar lbf/in ²	20 300	20 300	20 300	20 300	20 300
Weight Empty	kg lb	43 94	57 126	65 144	110 244	181 400
Weight Full	kg lb	151 334	202 446	247 544	396 874	562 1240
Shipping Weight	kg lb	44 98	59 131	68 150	120 264	194 428
Shipping Dimensions Depth	mm in	546 211/2	587 231/8	587 231/8	692 271/4	914 36
Shipping Dimensions Width	mm in	486 19 1/8	537 21 1/8	537 21 1/8	651 25 5/8	762 30
Shipping Dimensions Height	mm in	1194 47	1245 49	1499 59	1575 62	1829 72

**Hi-Flo
RANGE**

ANDREWS MODEL NO.		L32/143	L65/169	L81/251	L62/309	L54/399
Storage Capacity	l gal	145 32	295 65	386 81	282 62	245 54
Recovery thro' 44°C/80°F	l/h gal/h	649 143	788 169	1140 251	1403 309	1812 399
Recovery thro' 56°C/100°F	l/h gal/h	517 114	613 135	913 201	1122 247	1449 319
Recovery thro' 72°C/130°F	l/h gal/h	399 88	472 104	699 154	862 190	1117 246
Heat Input Gross	kW Btu/h	41.8 142,622	49 167,188	76 259,312	92.5 315,610	122 416,264
Heat Input Net	kW Btu/h	38 129,656	44 150,128	69 235,428	84 286,608	111 378,732
Gas		LPG CAT I ₃				
Inlet Gas Pressure	Propane mbar ins wg.	37 14.86	37 14.86	37 14.86	37 14.86	37 14.86
	Butane mbar ins wg.	28 11.26	28 11.26	28 11.26	28 11.26	28 11.26
Gas Flow Rate Propane	m ³ /h ft ³ /h	1.61 57	1.89 66.87	2.93 103.7	3.58 126.25	4.71 166.50
Gas Flow Rate Butane	m ³ /h ft ³ /h	1.26 44.6	1.48 52.24	2.29 81.04	2.79 98.63	3.68 130.08
Gas Connection	Rc (in BSP Int)	3/4	3/4	3/4	3/4	3/4
Flue Gas Temp	°C	125	125	170	190	170
Flue Gas Volume	m ³ /h	57	67	104	126	167
Gas Injector Orifice Diameter	mm in	1.60 0.063	1.70 0.067	1.85 0.073	1.78 0.070	1.78 0.070
Flue Size (Secondary)	mm in	150 6	150 6	200 8	200 8	250 10
Cold Water Feed Connection	R (in BSP/ExI)	11/2	11/2	11/2	11/2	11/2
Hot Water Flow Connection	R (in BSP/ExI)	11/2	11/2	11/2	11/2	11/2
*Return Connection	Rp (in BSP/Int)	3/4	3/4	3/4	3/4	3/4
Drain Port Size	R (in BSP/Ext)	3/4	3/4	3/4	3/4	3/4
Max. Working Pressure	bar lbf/in ²	10.3 150	10.3 150	10.3 150	10.3 150	10.3 150
Max. Test Pressure	bar lbf/in ²	20 300	20 300	20 300	20 300	20 300
Weight Empty	kg lb	190 419	200 441	289 687	294 515	269 594
Weight Full	kg lb	335 738	488 1091	656 1447	618 1135	514 1134
Shipping Weight	kg lb	199 438	230 492	316 697	287 566	293 645
Shipping Dimensions Depth	mm in	902 35 1/2	914 36	914 36	914 36	914 36
Shipping Dimensions Width	mm in	768 30 1/4	762 30	762 30	762 30	762 30
Shipping Dimensions Height	mm in	1270 50	1960 77	2210 87	1960 77	1960 77

* If the water heater is to be used on an unvented system, the combined temperature/pressure relief valve must be fitted directly into the tank. The secondary return is then connected to the drain port via a suitable tee.

INTRODUCTION

THE LAW REQUIRES THAT INSTALLATION IS CARRIED OUT BY A PROPERLY QUALIFIED PERSON

Installations must be carried out in accordance with Gas safety (Installation and Use) Regulations 1998, Building Regulations, The Water Supply (Water Fittings) Regulations 1999 and any requirements of the local Gas Authority, Local Authority, Water and Fire Authorities and the current British Standards and Codes of Practice listed in Section 1.

The fittings pack supplied with the heater contains the items listed below.

- 1 - Installation and Service Manual.
- 1 - Coupler Socket $\frac{3}{4}$ in BSP.
- 1 - Gas Cock.
- 1 - Drain Cock.
- 1 - Flue Adaptor Socket (Where required).
- 2 - Cap End $1\frac{1}{2}$ in BSP (Hi-Flo only).
- 2 - $1\frac{1}{2}$ in x 3in Nipples (L32/143 Model only).
- 1 - Warranty Card.

ASSEMBLING THE DRAUGHT DIVERTER

The draught diverter must be assembled with the legs provided.

Attach the legs to the draught diverter with the nuts and bolts provided. Fit the draught diverter (1) as shown in Fig.1 to the water heater using the screws provided.

For Standard Range fit the draught diverter to the top of the water heater using the location holes.

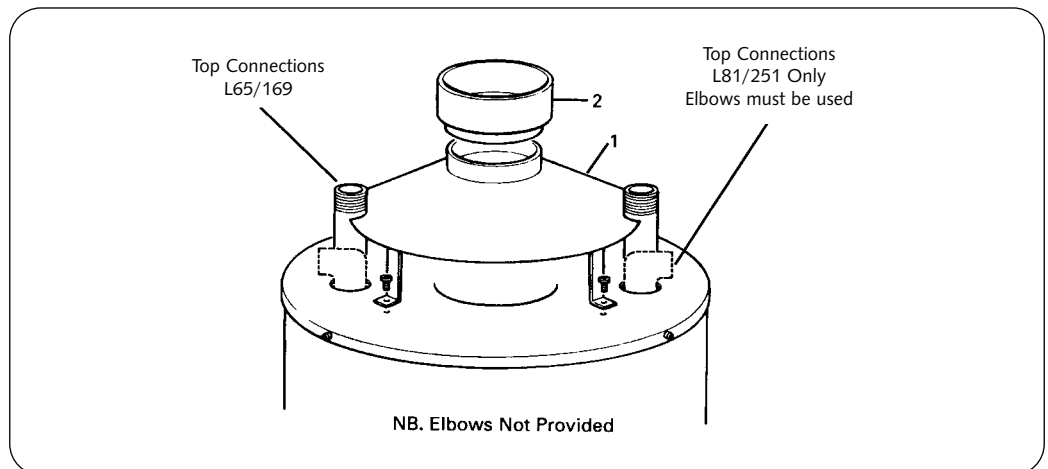

Fig. 1
Draught Diverter
Assembly

In some cases, it may be necessary to drill the fixing holes in the top cover to fit the draught diverter to the water heater. By using the draught diverter as a template, position carefully over the flueway and mark the hole positions to be drilled 4mm.

Fit the adaptor socket (2) and caulk into the draught diverter as shown in Fig. 1.

LOCATION

The location selected for installation of the heater must allow the provision of a satisfactory flue, adequate air supply, drain facilities and must be well illuminated.

A purpose built boiler room or compartment is strongly recommended.

A manual valve for isolation of the boiler room should be installed in the gas supply; it should be clearly identified and readily accessible for use at all times.

If a purpose built boiler room is not available, measures should be taken to protect the heater from damage and prevent any extraneous matter from being stored on or around the heater.

See BS 6644 Clauses 4, 5 and 6 for details.

The heater must not be installed in any location which contains a bed, bath or shower.
The heater must not be installed in a basement or cellar.
There must be easy access to the boiler room and heater at all times.

A clearance of 800mm (31½ in) for Hi-Flo and 300mm for Standard Range should be left at the front of the heater for removal of the burner.

Clearances at the sides and rear of the heater should be at least 305mm (12in).

Service clearances for removal of the anodes and flue baffles should be provided as detailed below. Note! Where restricted headroom is a problem, articulated anodes can be supplied. Andrews Part No. C333.

STANDARD RANGE

Models L24/31, L32/35, L40/36	762mm (30 in)
Model L63/71	1143mm (45 in)
Model L84/71	1270mm (50 in)

HI-FLO RANGE

Model L32/143	597mm (23½ in)
Model L81/251	1300mm (52 in)
Models L65/169, L62/309, L54/399	1143mm (45 in)

The floor on which the heater is installed must be non-combustible, flat, level and of sufficient strength to withstand the weight of the heater filled with water (see Section 2, Technical Data) and should satisfy the requirements of the Local Authority and Building Regulations.

NOTE:

If the heater is in an exposed position and out of use during a period of heavy frost, it is recommended that the whole system is drained down to prevent damage due to the formation of ice inside the storage vessel.

THE ANDREWS WATER HEATERS COVERED IN THIS MANUAL MUST ONLY BE USED WITH PROPANE OR BUTANE GAS.

Contact Calor Gas who will provide the appropriate type and size of LPG supply vessel and ensure it's safe location and installation.

The installation of the gas supply must conform to LPGA Code of Practice, 22 LPG Piping Systems: Design and Installation plus the requirements of British Standards and Codes of Practice listed in Section 1 of this manual.

Andrews water heaters are unregulated and a second stage regulator must be installed to give an inlet pressure to the appliance as follows:

PROPANE: 37mbar (14.86 in wg)
BUTANE: 28mbar (11.26 in wg)

Gas Supply Cock, Standard Models

Fit the gas supply cock immediately upstream of the gas control thermostat using a suitable jointing compound and connect to the gas supply. Do not apply heat in close proximity to the gas thermostat as damage to the control will result. A pressure test point nipple is fitted to the gas control thermostat at the gas inlet to test the incoming gas pressure.

LOCATION

GAS SUPPLY

GAS SUPPLY

Gas Supply Cock, Hi-Flo Models

Fig 2.

Fit the gas cock immediately upstream of the gas control valve using a suitable jointing compound and connect to the gas supply. An inlet nipple complete with pressure test point nipple is factory fitted to the gas control valve to avoid possible damage.

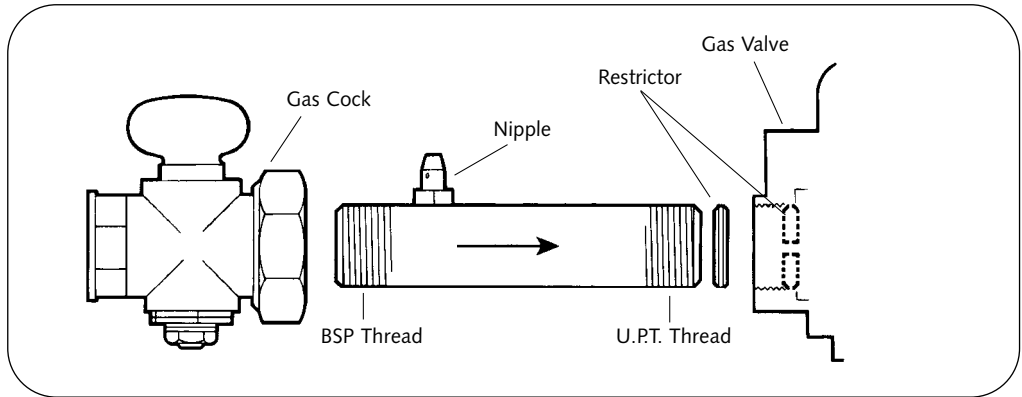

Fig 2.

Where the water heater(s) is(are) installed in a boiler house or purpose built compartment, a manually operated valve for the boiler house must be fitted in accordance with the Gas Safety (Installation and Use) Regulations 1998. The valve must be easily identified and readily accessible.

After installation, the system should be pressure tested for soundness and purged in accordance with BS 6891 or IM/2 and IM/5 as appropriate.

INSTALLATION OF THE LPG SUPPLY

Fig. 3

When using propane or butane cylinders connect a minimum number of cylinders as listed below, together with a manifold before connecting to the union. Use a minimum pipe size of 3/4 in bore.

One cylinder	All Standard Range Models
Two cylinders	Hi Flo Models L32/143, L65/169, L81/251
Three cylinders	Hi Flo Model L62/309
Four cylinders	Hi Flo Model L54/399

WARNING!

PROPANE AND BUTANE CYLINDERS MUST BE USED AND STORED IN ACCORDANCE WITH 'THE HIGHLY FLAMMABLE LIQUIDS AND LIQUIFIED PETROLEUM GASES REGULATIONS 1972', AND SHOULD COMPLY WITH LPG CODE OF PRACTICE 7, 'STORAGE OF FULL AND EMPTY LPG CYLINDERS AND CARTRIDGES.

Bulk Storage Vessel Installation

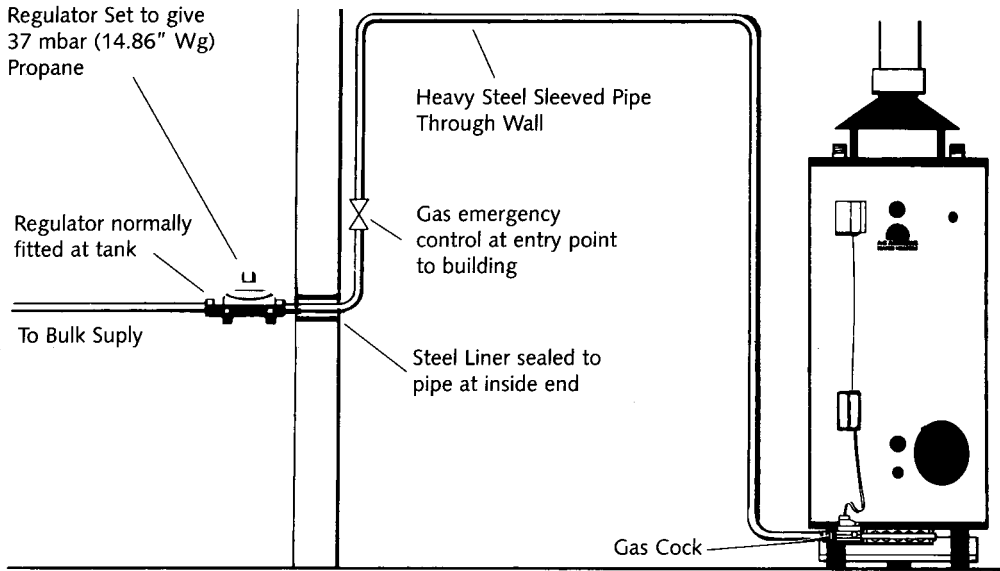

Cylinder Installation

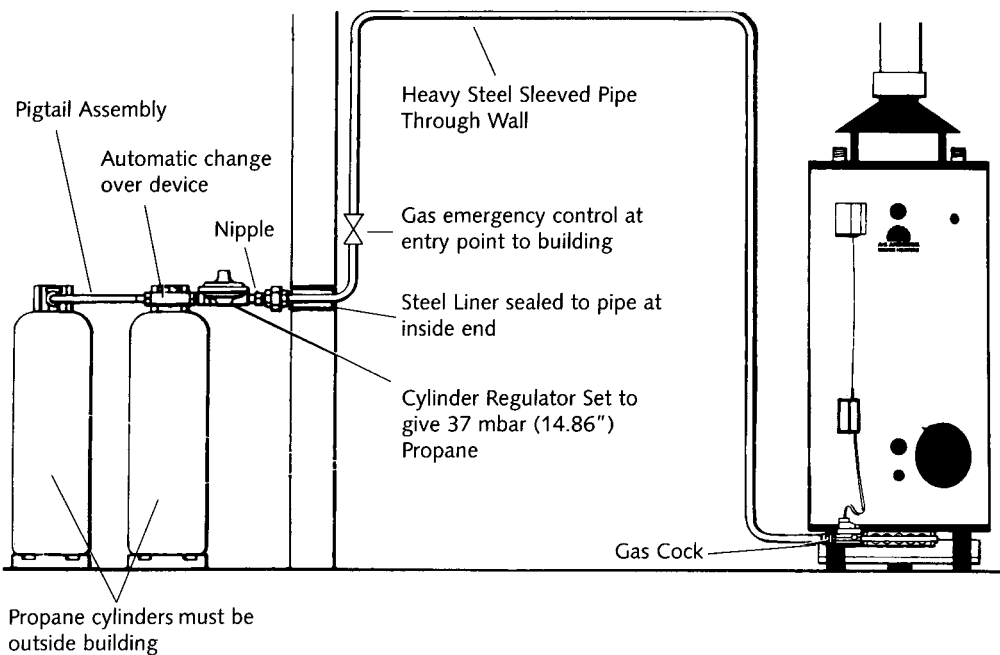

Fig 3.

**ELECTRICAL
SUPPLY-
AUTO IGNITION
UNIT**

STANDARD RANGE MODELS

External wiring to the water heater(s) must be installed in accordance with current I.E.E. Regulations for the wiring of buildings and to any Local Regulations that may apply.

The Auto Ignition Heater is designed to operate from a 220/240V, 1Phase supply. The fuse rating is 5 amps.

The method of connection to the mains electricity supply should facilitate complete electrical isolation of the appliance, preferably by use of an unswitched shuttered socket outlet in conjunction with a fused three pin plug, both complying with the requirements of BS 1363.

Alternatively, a fused double pole switch or fused spur box serving only the heater may be used.

The point of connection to the mains electricity supply should be readily accessible and adjacent to the appliance.

Fig 4.

Connect the electrical supply to the main control panel terminal block via the cable glands in the base of the control panel. Mains input cable should be 0.75mm², 3 core, and should be connected to the mains supply as detailed above.

It is recommended that screen cable is used where the volt-free contacts are to be connected from an external supply. This will eliminate the risk of possible interference from nearby high voltage cables.

A separate data sheet is available for Automatic Ignition Control System. Contact Andrews Water Heaters.

Fig 4.

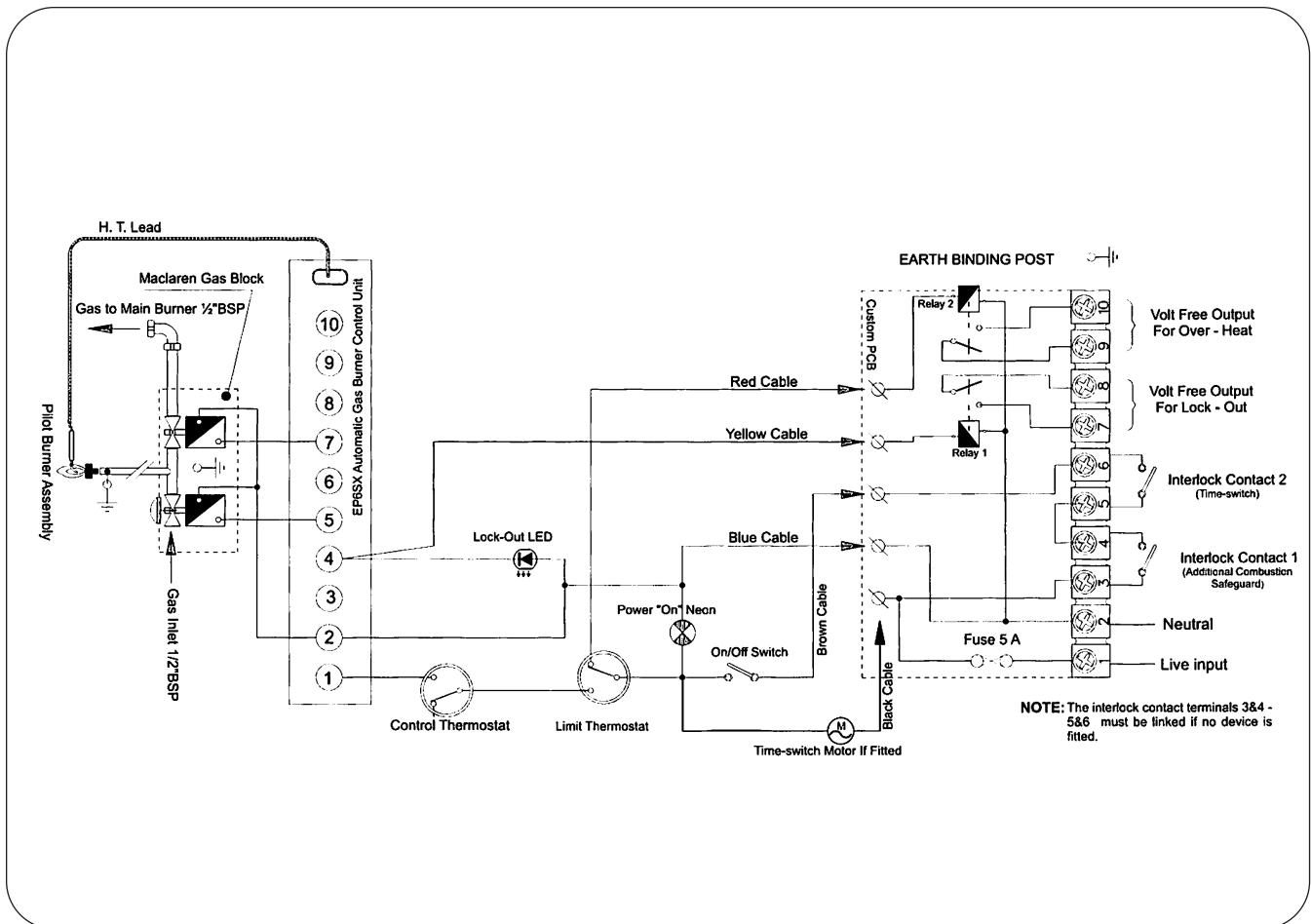

FLUE SYSTEMS

Detailed recommendations for flue installation are given in BS 6644, BS5440 Pt 1 and British Gas publication IM/11 - Flues for Commercial and Industrial Gas Fired Boilers and Air Heaters. See also IGE/UP/10 Pt1.

The flue connection is designed for BS 835 type heavy duty flue, but light quality flue pipe, mild steel or stainless steel sheet may be used using the appropriate adapter. Flue pipes etc. shall be fitted socket-up to keep any condensate within flue and appliance. Flues up to 200mm (8in) diameter should be fitted with a suitable British Gas Certified terminal.

Fig 5a.

The terminal position is most important and must be at least 1000mm (40in) above roof surfaces or at least 600mm (24in) above any parapet and clear of any adjacent obstruction as well as being clear of any openable windows, ventilators or features which could allow re-entry of flue products into the building. Pressure areas should also be avoided to prevent blowdown. See recommendations in BS 6644 and IGE/UP10Pt1. BS 5440 Part 1 also provides useful additional advice.

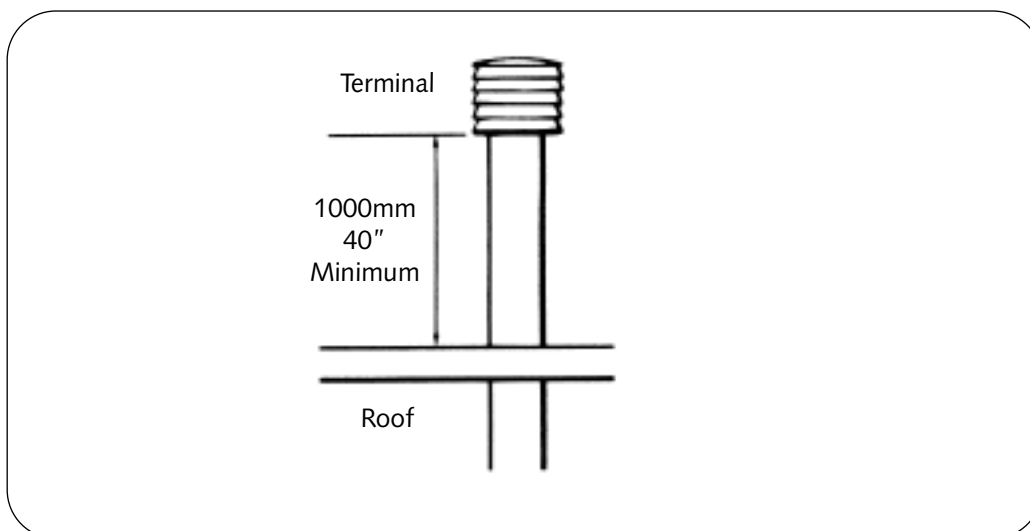

Fig 5a.
Terminal

Flue materials, including jointing materials and fittings shall be asbestos-free, robust, durable, corrosion resistant and non-combustible and shall comply with BS 5854 and BS 715 or BS 4076 as appropriate, as well as being of a type accepted by the Local Gas Authority.

When passing up through or adjacent to combustible materials, measures shall be taken to prevent the temperature of the combustible material from exceeding 60°C (150°F). The flue shall not be closer than 50mm (2in) to any combustible material except when passing through, when it must be enclosed by a non-combustible sleeve and separated from the sleeve by not less than 25mm (1in) air space.

Flues shall be of a size not less than specified in Section 2, Technical Data (i.e. nominal flue size) and fitted so that there is no risk to persons in the building or from accidental damage.

Fig 5b.

If using an existing brick chimney, it should be swept and checked for soundness before connecting the flue and should take the shortest possible route and rise continuously to the terminal avoiding the use of 90° bends where a change of direction is required. Horizontal and very shallow runs of flue should be avoided since they impede the flow of gases and increase local cooling.

FLUE SYSTEMS

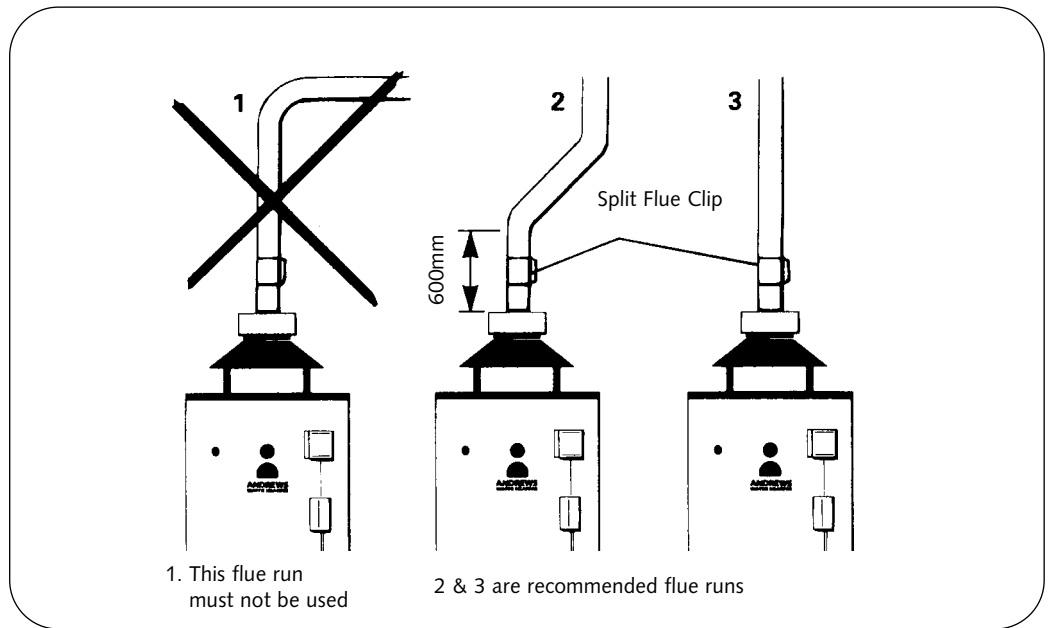

Fig 5b.

*A minimum of 600mm of vertical flue directly above the draught diverter should be provided where possible on all natural draught flue installations. If this dimension cannot be achieved please contact Andrews Water Heaters. Please note this is not required where a common flue header is used on multiple installations.

Fig 6.

Common flues may be used on multiple installations only if all the heaters are of the same burner system and fuel type and should be sized to ensure complete evacuation of the flue products from the installation.

Where one flue is to be used more regularly or for longer periods than the others in the group, it should be connected at the point nearest to the main flue. See BS 6644 Clause 20 for further information and recommendations on this as well as general flue requirements.

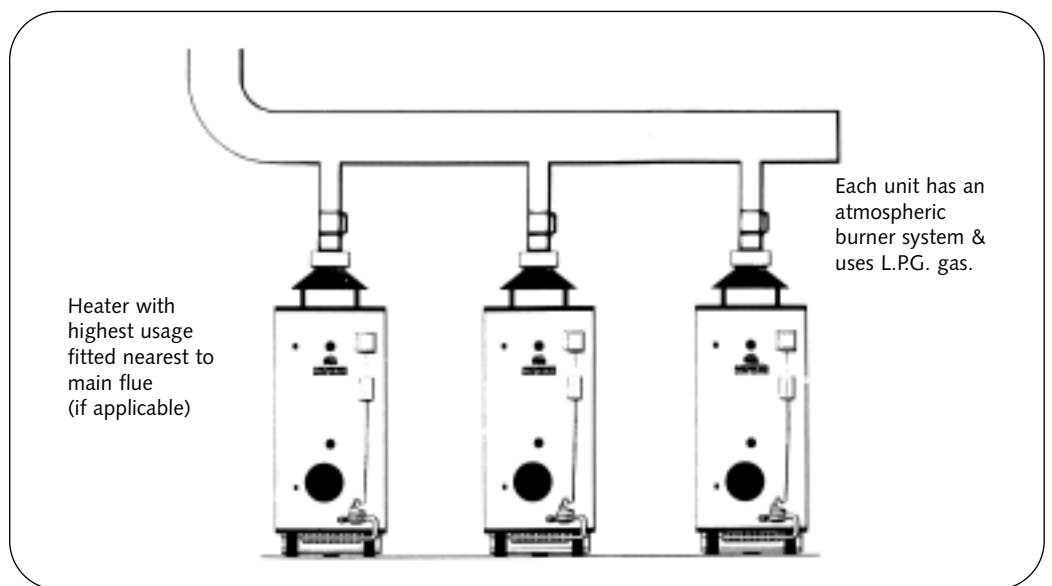

Fig 6.

Fit a flue clip or flange joint close to the diverter so that it is secure but can be disconnected for servicing. The weight of the flue must be borne by securing clips, etc. and not by the heater.

Minimum Heights from Roof to Base of Flue Terminal

Type of Roof		Not within 1.5m (5ft) of a vertical surface of a structure ≠ on the roof			Within 1.5m (5ft) of a vertical surface of a structure ≠ on the roof	
		Internal Route		External Route	Internal Route	External Route
		On Ridge	Not on Ridge			
Pitched	Pitch exceeding 45°	At or above ridge level	1m (3.3 ft) above roof intersection	1m (3.3 ft) above roof intersection	The base of the terminal should be 600 mm (24 in) above the level of the top of the structure	
	Pitch not exceeding 45°		600 mm (24 in) above roof intersection	The base of the terminal should be 600 mm (24 in) above the level of the adjacent roof edge		
Flat	With parapet	Not applicable	600 mm (2 ft) above roof intersection			
	Without parapet		250 mm (10 in) above roof intersection			

For all installations, please refer to the table below for calculating requirements. Detailed recommendations for the air supply are given in BS 5440 Part 2, BS 6644 Clause 19 and IGE/UP/10 Pt1.

The following notes are provided for general guidance only.

Ventilation shall prevent the heater environment from exceeding 32°C (90°F).

The purpose provided space in which the heater(s) are installed must have permanent air vents communicating directly with the outside air, at high and low level. Where communication with the outside air is possible only by means of high level air vents, ducting down to floor level for the lower vents must be used.

For an exposed building, air vents must be fitted on at least two sides, preferably on all four sides.

Air vents should have negligible resistance and must not be sited in any position where they are likely to- be easily blocked or flooded, or in any position adjacent to an extraction system which is carrying flammable vapour.

Grilles or louvres should be so designed that high velocity air streams do not occur within the space housing the heater(s).

The grilles should have a total minimum free area for the water heater(s) in addition to any other requirements as follows:-

Where the heater is to be installed in a room the following permanent ventilation is required:

5cm² per kW in excess of 7kW Net for installations up to 54kW Net.

For installations exceeding 60kW the following permanent ventilation is required:

Low Level (inlet) 540cm² plus 5cm² per kilowatt in excess of 54kW total Net input.

High Level (outlet) 270cm² plus 2.5cm² per kilowatt in excess of 54kW total Net input.

Where the heater is to be installed in a compartment, permanent air vents are required in the compartment at high and low level. These air vents must either communicate with a room or internal space or be direct to outside air.

The minimum effective areas of the permanent air vents required in the compartment are as follows:-

Position of Air Vents	Air Vent Areas	
	Air from room or internal space	Air direct from outside
High Level	10cm ² per kW Net	5cm ² per kW Net
Low Level	20cm ² per kW Net	10cm ² per kW Net

Note:- Both air vents must communicate with the same room or internal space or must both be on the same wall to outside air.

AIR SUPPLY AND VENTILATION

AIR SUPPLY AND VENTILATION

IMPORTANT!

1. The effective area requirements specified in the table are related to the net heat input of the heater(s) and are equivalent to those specified in BS 6644 and IGE/UP10 Pt1.
2. The free area of the grilles should not be less than the size of the recommended ventilation opening.
3. The supply of air to a space housing the heater(s) by mechanical means should be:
 - (a) Mechanical inlet with natural extraction.
 - (b) Mechanical inlet with mechanical extraction.

NOTE! Natural inlet with mechanical extraction must not be used.

Where a mechanical inlet and mechanical extraction system is used, the design extraction rate must not exceed one third of the design inlet rate.

All mechanical ventilation systems must be fitted with automatic gas shut off safety systems which cut off the supply of gas to the heater(s) in the event of failure of either the inlet or extract fans.

The requirements for air supply by mechanical ventilation are given in BS 6644 Clause 19.3 and IGE/UP/10 Pt1.

The permanent air vents shall be sited away from any extract fans. Where an extract fan is fitted, check for spillage at the draught diverter as detailed in BS 5440 Part 1 Appendix B. It may be necessary to increase the ventilation area to compensate for the extract fan.

4. The vapours emitted by halogen based compounds can, if drawn into the combustion air, cause corrosion of the gas burner, thermocouple and storage vessel. Therefore, if heaters are to be installed in locations where halogens are likely to be present, they should be isolated from such compounds and ventilated from and to outside uncontaminated atmosphere.

Some of the vulnerable areas are:

- (a) Hairdressing salons and adjoining rooms and basements
- (b) Establishments where dry cleaning solutions are used or stored.
- (c) Degreasing plants using hydrocarbon solvents.
- (d) Premises where refrigerant gases are used or stored.

WATER QUALITY AND TREATMENT

Where extreme conditions of water hardness exist, scale can form in any water heating equipment, especially when the heater is working under conditions of constant heavy demand and at high temperatures.

Each water heater is fitted with one or more magnesium anode(s) which protect the tank from corrosion caused by electrolytic action. Magnesium anodes are sacrificial in that they corrode as they protect. When the anode has eroded to less than 50% of its original diameter, it may not offer protection. The anodes should be inspected annually and replaced as necessary. Frequency of anode replacement will vary dependent on water quality.

Andrews Water Heaters offer Correx™ UP powered anodes as an alternative to the standard magnesium anodes. These anodes do not need maintenance or replacement. The potentiostat which regulates the current to the Correx™ anode, features an indicator light which shows green to indicate correct function and red to indicate malfunction. These anodes are available as an optional extra on all Andrews heaters.

In hard water areas, scale formation can occur in hot water systems and hot water heaters and the higher the temperature and volume of water used, the more problematic the scale build-up can be. Water treatment is normally recommended when the hardness reaches 100 - 150ppm (7 - 10 degrees Clark) and above. This problem can be minimised by reducing the water temperature in the heater and by fitting suitable water pre-treatment equipment.

When installing Andrews Water Heaters in hard water areas we would recommend that a water treatment specialist is consulted.

WATER CONNECTIONS

Hydrojet System

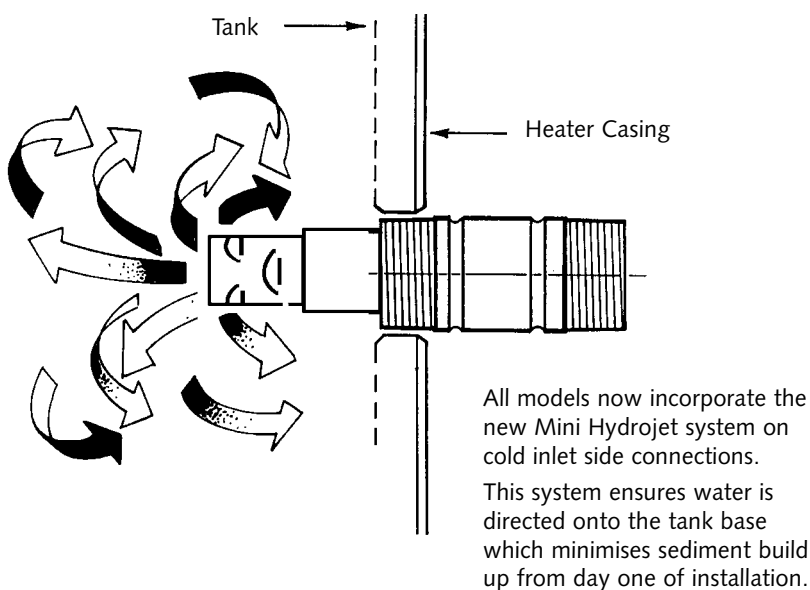
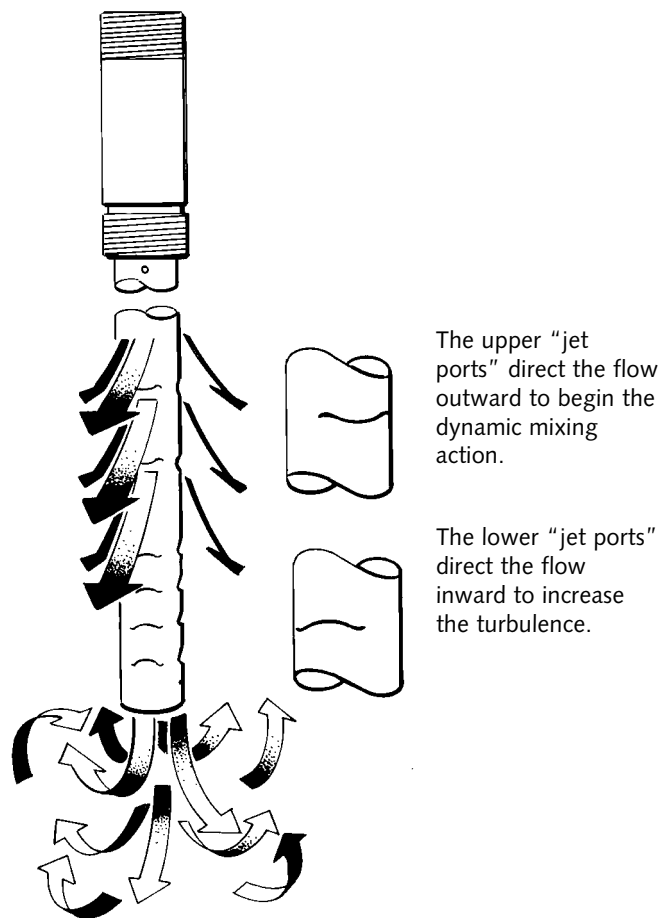

Mini Hydrojet Inlet Nipple (Side Cold Inlet Connection)

The heater is fitted with the Hydrojet Total Performance System incorporated in the cold inlet dip tube. The tube is designed to increase turbulence and reduce sediment build up, reduce thermal stacking and increase delivery.

WATER CONNECTIONS

VENTED SYSTEMS, STANDARD RANGE

The water heater must be supplied from a cold water feed cistern and the hot water supply pipe must be fitted with an open vent pipe in accordance with BS 5546 and BS 6644.

The Water Supply (Water Fittings) Regulations 1999 must be observed when installing the system.

The cold water feed cistern must have an actual capacity greater than the hourly recovery rate of the heater or heaters to which it is fitted, the minimum actual capacity allowed for a feed cistern being 227 litres (50 gallons).

The actual cistern capacity is the capacity to the normal water line of the cistern.

All cisterns should be manufactured to the relevant British Standard.

The distance from the normal water line to the top of the cistern should comply with that specified by the Water Authorities.

The cold water inlet and hot water outlet connection nipples are identified on top of the heater.

Connect the cold water feed and hot water outlet to these nipples with union adaptors for ease of servicing.

CAUTION!

DO NOT APPLY HEAT TO THESE NIPPLES IF MAKING CAPILLARY SOLDERED JOINTS AS THEY ARE FITTED WITH PLASTIC INSERTS. MAKE THE CAPILLARY JOINTS TO THE PIPES BEFORE CONNECTING TO THE HEATER. A DRAIN COCK IS SUPPLIED WITH THE HEATER AND THIS SHOULD BE FITTED TO THE APPROPRIATE BOSS AS SHOWN ON THE DRAWING.

After installation of the water system, open the main water supply valve, flush the system and fill the heater.

Open the hot taps to allow air to escape from the system.

When the water is free of air, close the taps and check for leaks at the gas control thermostat, drain cock and the pipe connections at the top of the heater.

All water connections for Standard Range are shown in Fig 7.

Typical water service layout for Standard Range single heater vented system is shown in Fig 8.

Typical water service layout for Standard Range multiple heater vented system is shown in Fig 8A.

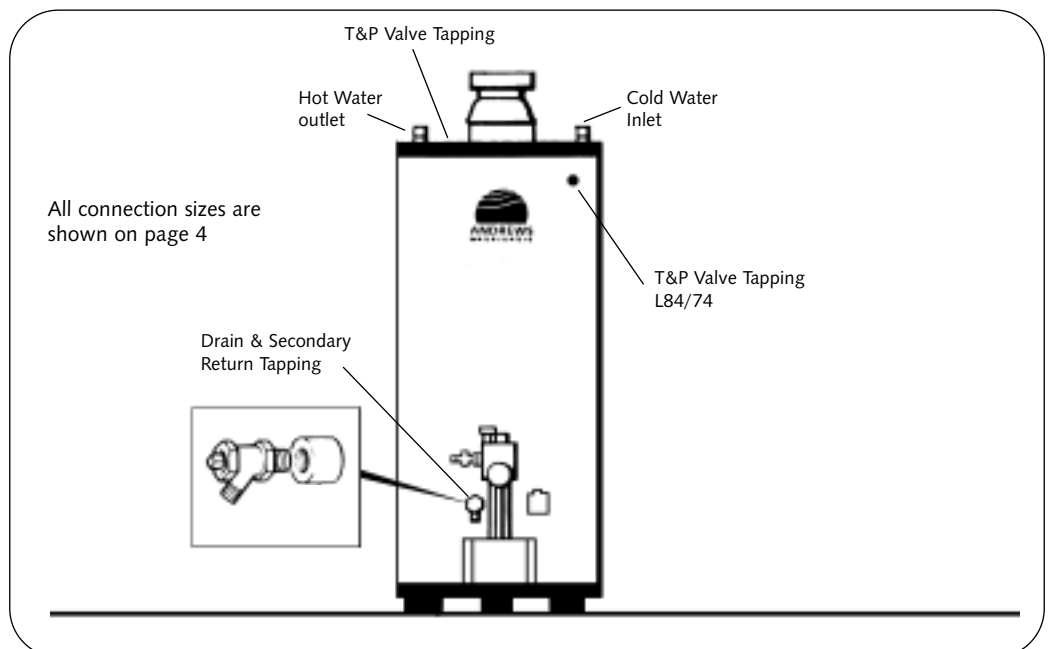

Fig 7.

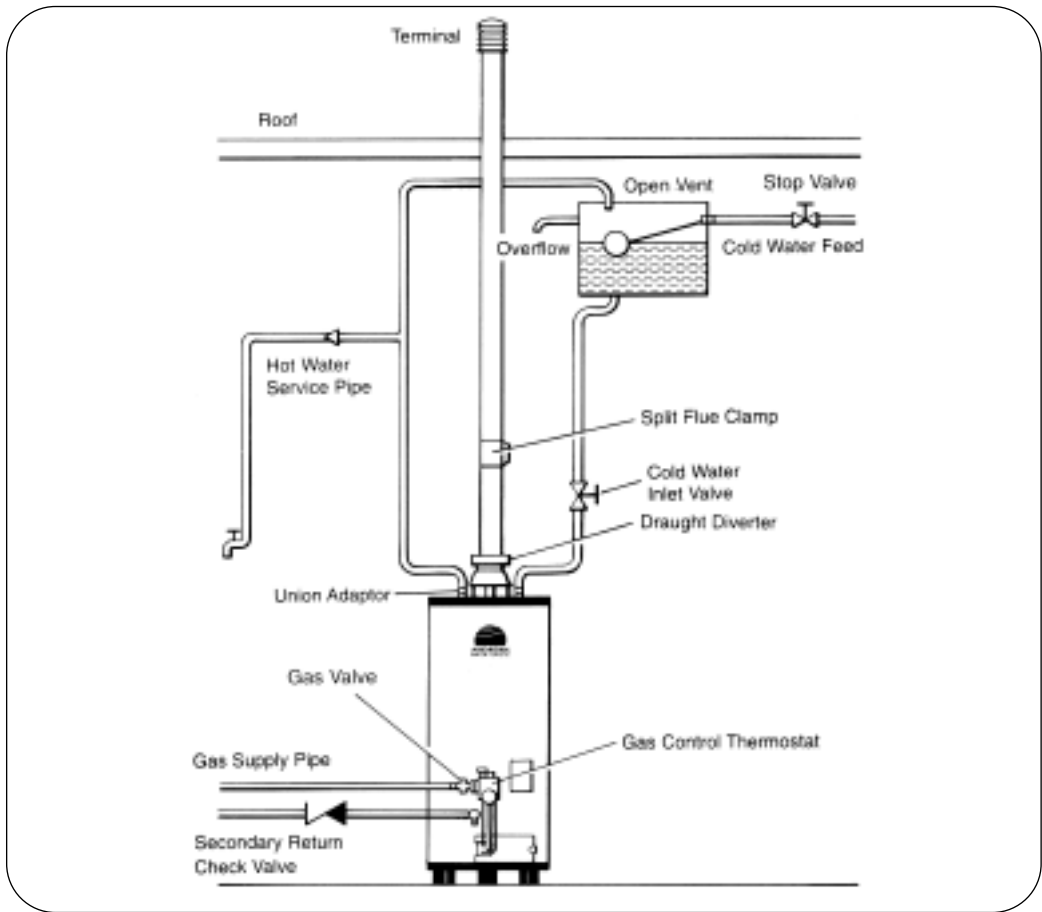

Fig 8.

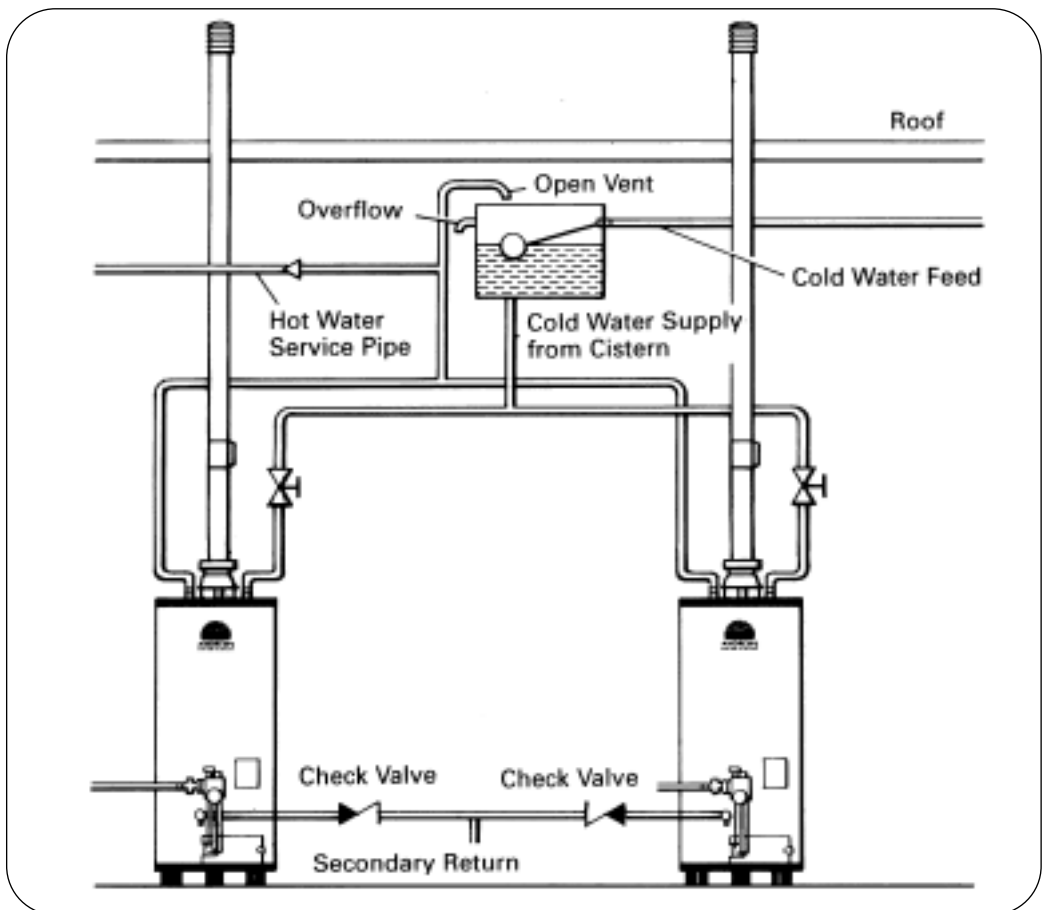

Fig 8a.

WATER CONNECTIONS

UNVENTED SYSTEMS, STANDARD RANGE

Unvented Systems should be fitted by an Approved Installer. When used in an unvented system, the Andrews Water Heater will supply hot water at a pressure of 3.5bar (50.8lbf/in²) provided that this pressure is available at the mains feed. During conditions of no-flow, system pressure may rise to a maximum of 6bar (87lbf/in²) whilst the burner is operating. When testing the system, it is recommended that a maximum test pressure of 8.62bar (125lbf/in²) is employed.

Fig. 9

The heater can be used on unvented hot water storage systems, with the addition of an Unvented Systems Kit, part number B171 available from Andrews Water Heaters. See Parts List Page 49. The Wall Mounting Kit is available as an optional extra.

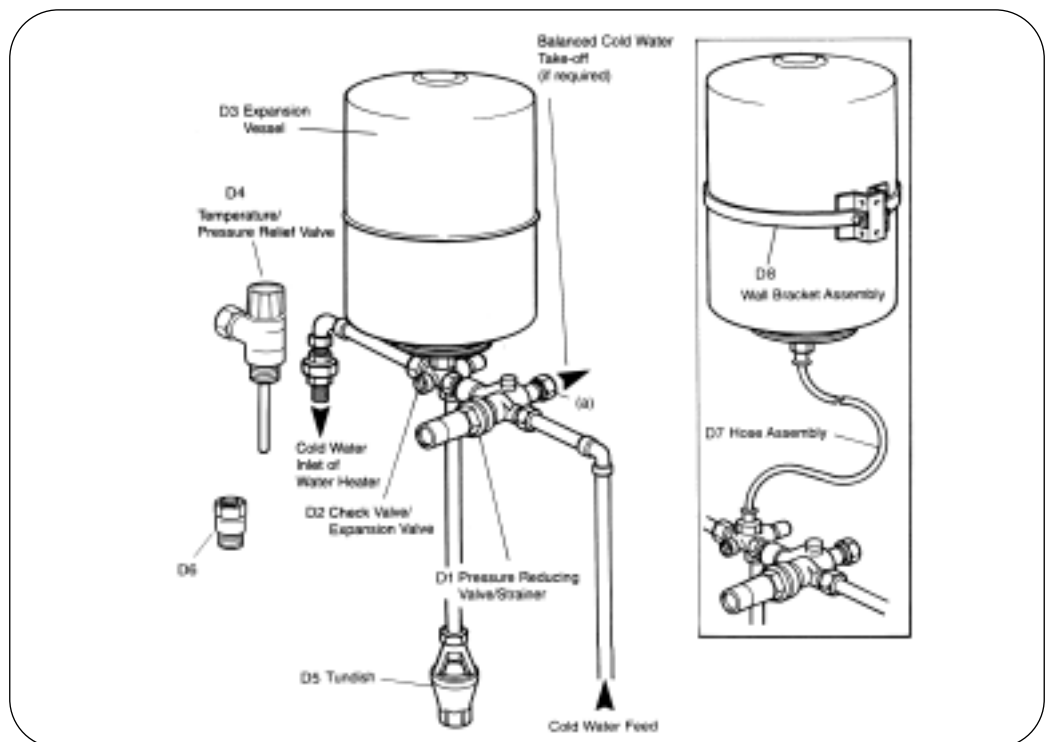

Fig 9.

Item D4 must be fitted into the temperature relief port in the water heater tank. D6 Adaptor - For use with D4 on heater models L40/36, L63/71 & L84/74. When assembling items D1 and D2, ensure that the flow arrows marked on the components are pointing in the direction of flow i.e. towards the water heater.

The cold water for services may be drawn from the 22mm compression port on item D1 (a). The water pressure at this point will be similar to that available at the hot water outlet of the water heater. If port (a) is not used, it should be sealed with the blanking plug supplied.

If higher flow rates are required for the cold water services, a suitable tee fitting should be fitted to the pipework, upstream of item D1.

The pipework fitted to the tundish outlet should be at least 28mm diameter and should be terminated at a suitable drain (see Building Regulations 1992 Approved Document G3).

All fittings and materials must be suitable for use with drinking water and listed in the current Water Research Centre "Materials and Fittings Directory".

Installation of unvented hot storage water systems must comply with Part G3 of the Building Regulations 1992.

Typical water service layout for Standard Range single heater unvented system is shown in Fig 10.

Typical water service layout for Standard Range multiple heater unvented system is shown in Fig 11.

WATER CONNECTIONS

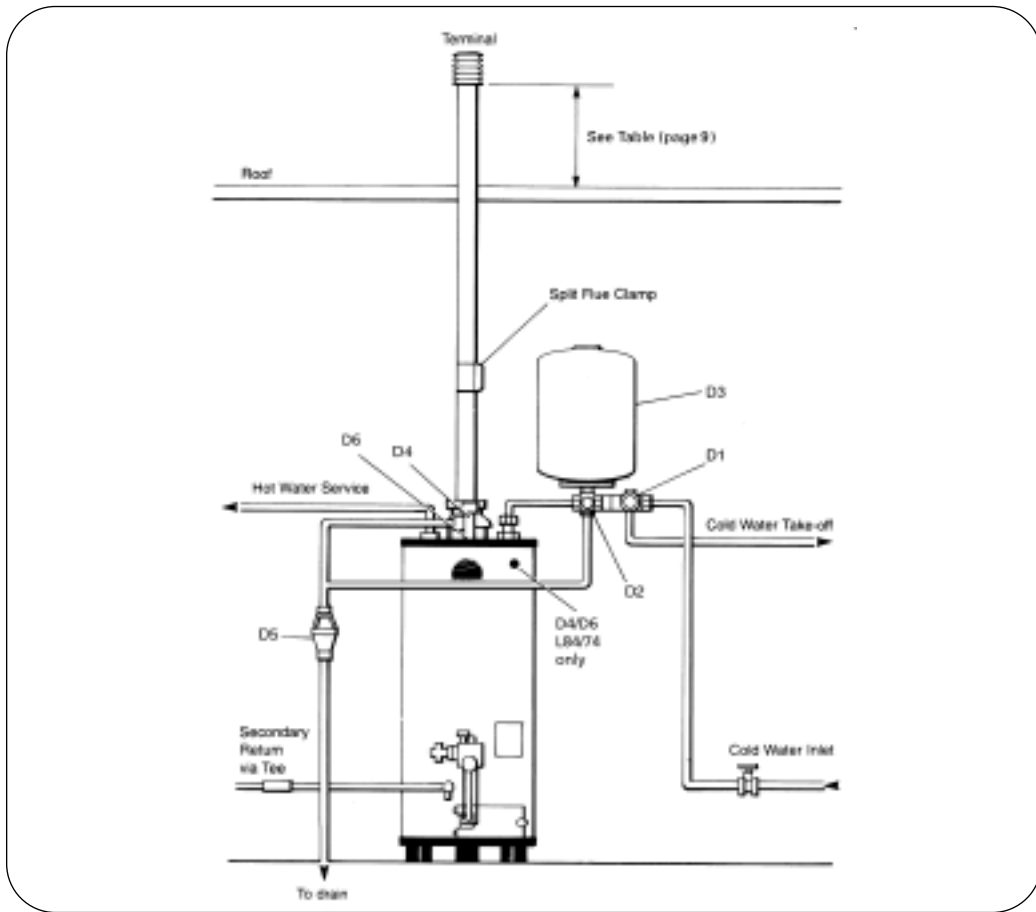

Fig 10.

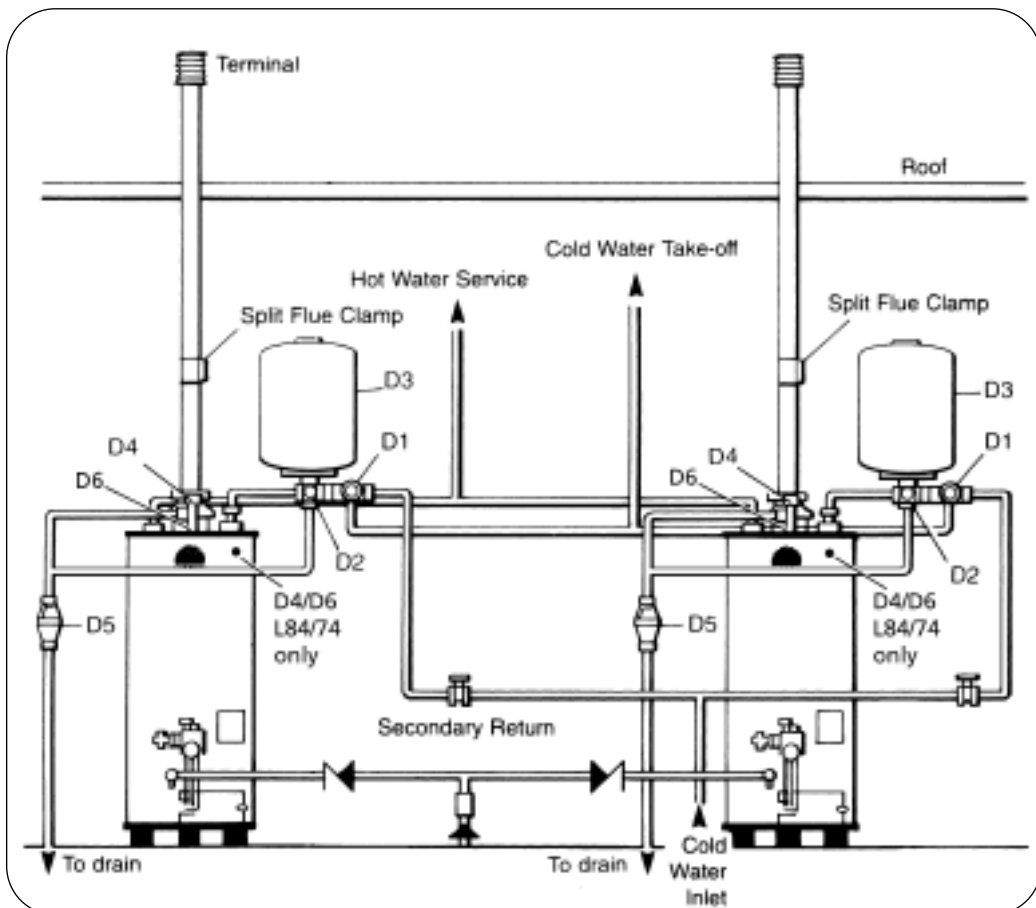

Fig 11.

WATER CONNECTIONS

VENTED SYSTEMS, Hi-Flo RANGE

The water heater must be fed from a cold water feed cistern or static water tank.

A safety valve must be fitted as specified in BS 6644 Clause 9. (see also Section 2, Technical Data)

The safety valve must be fitted either directly to an upper tank tapping or not further than 1 metre along the outlet flow pipe of size not less than the safety valve.

There must be no valve separating the heater from the safety valve.

The size of the discharge pipe must be not less than the nominal size of the safety valve outlet. It should be self-draining and any water discharged must be visible and create no hazard to persons in or about the building.

A low pressure open vented system can be used or where the natural circulating pressure is insufficient, pumped circulation can be employed.

The heater must be fitted with an open vent pipe which is not valved and which rises continuously to the open vent. It should be sized with reference to Technical Data, BS 6644 Clauses 9 and 10 and CP 342. Local Regulations and Bye-Laws must be observed when installing the system.

Water draw-off dead legs should comply with CP 342 Part 2, Table 1 and BS 6700.

Fig 12.

Models L65/169, L81/251. Optional top inlet/outlet water connections

Select the cold/hot location required (i.e. top inlet/outlet or front inlet/outlet) and, using a suitable jointing compound, blank off the two ports not required.

All Models. Front inlet/outlet water connections

Models 32/143. Optional rear inlet/outlet water connections

Assemble onto the 3/4 BSP thread, the 3/4 BSP couplet socket (1) and drain cock using a suitable jointing compound. Select the Cold/Hot location required and using a suitable jointing compound, blank off the two ports not required.

Models 32/143, 62/341, 54/418, 54/440

A 3/4 BSP thread connection is available at the top of the heater, this is suitable for a Automatic Air Vent if required (Not supplied).

NOTE

When using a secondary return circuit, see Fig 11 for the locations of the return tappings.

It is recommended that all water connections be made to the heater(s) using union fittings for ease of servicing. Pipe support intervals should comply with CP 342, Part 2 Table 4.

After Installation of the water system, open the main water supply valve, flush the system and fill the heater. Open the hot taps to allow air to escape from the system. When the system is free of air, close the taps and check for leaks at the gas control thermostats, drain cock and pipe connections on the heater.

Typical water service layout for Hi-Flo Range single heater vented system is shown in Fig 13.

Typical water service layouts for Hi-Flo Range multiple heater vented systems are shown in Figs 14 and 15.

WATER CONNECTIONS

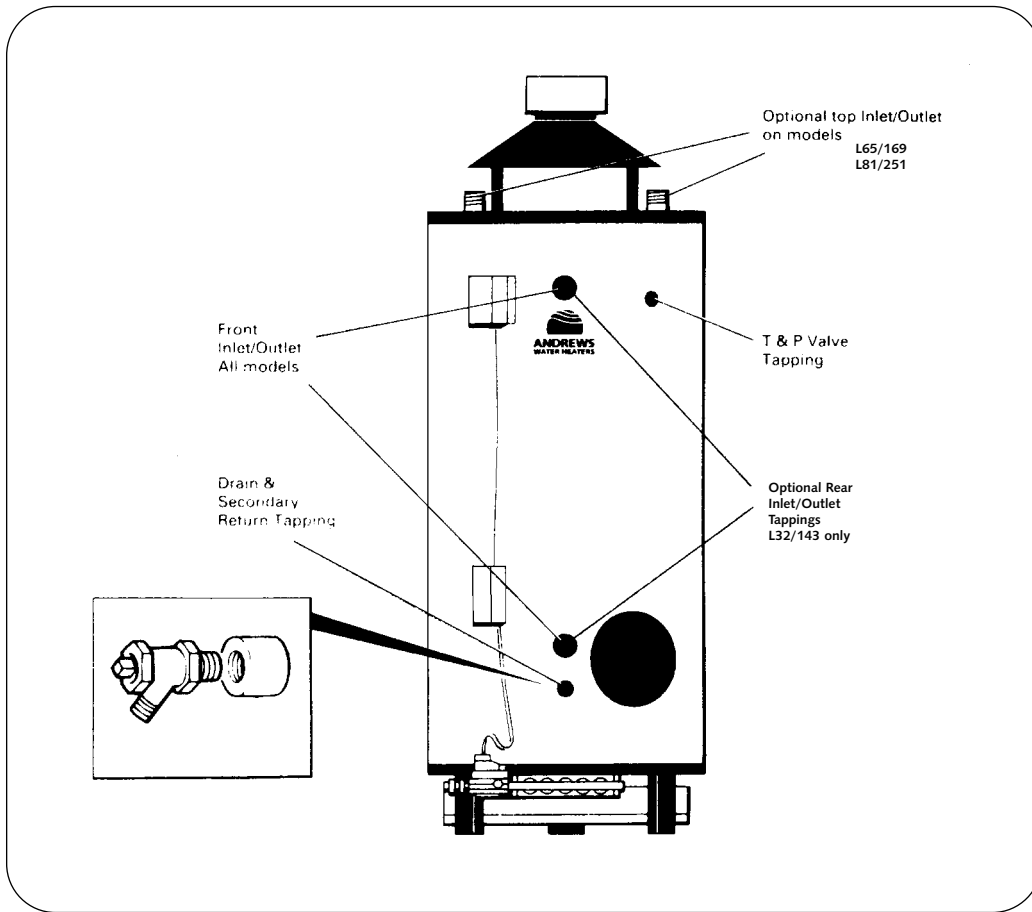

Fig 12.

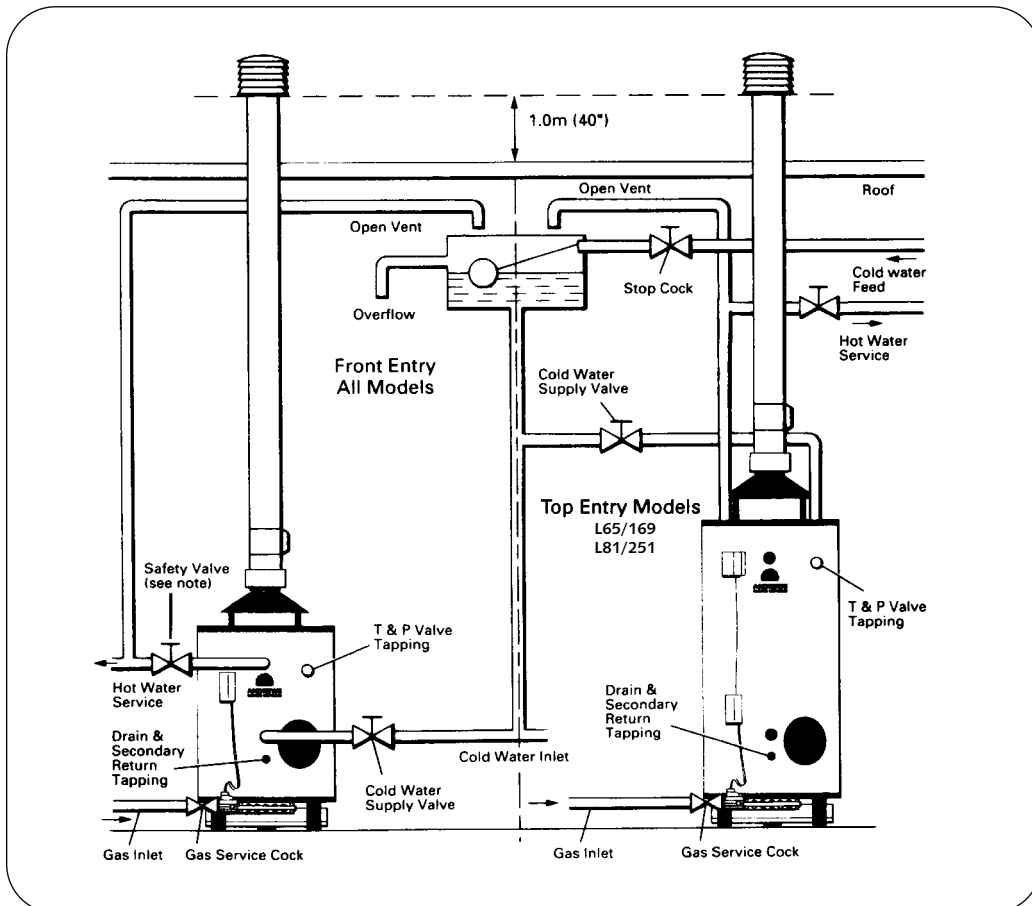

Fig 13.

WATER CONNECTIONS

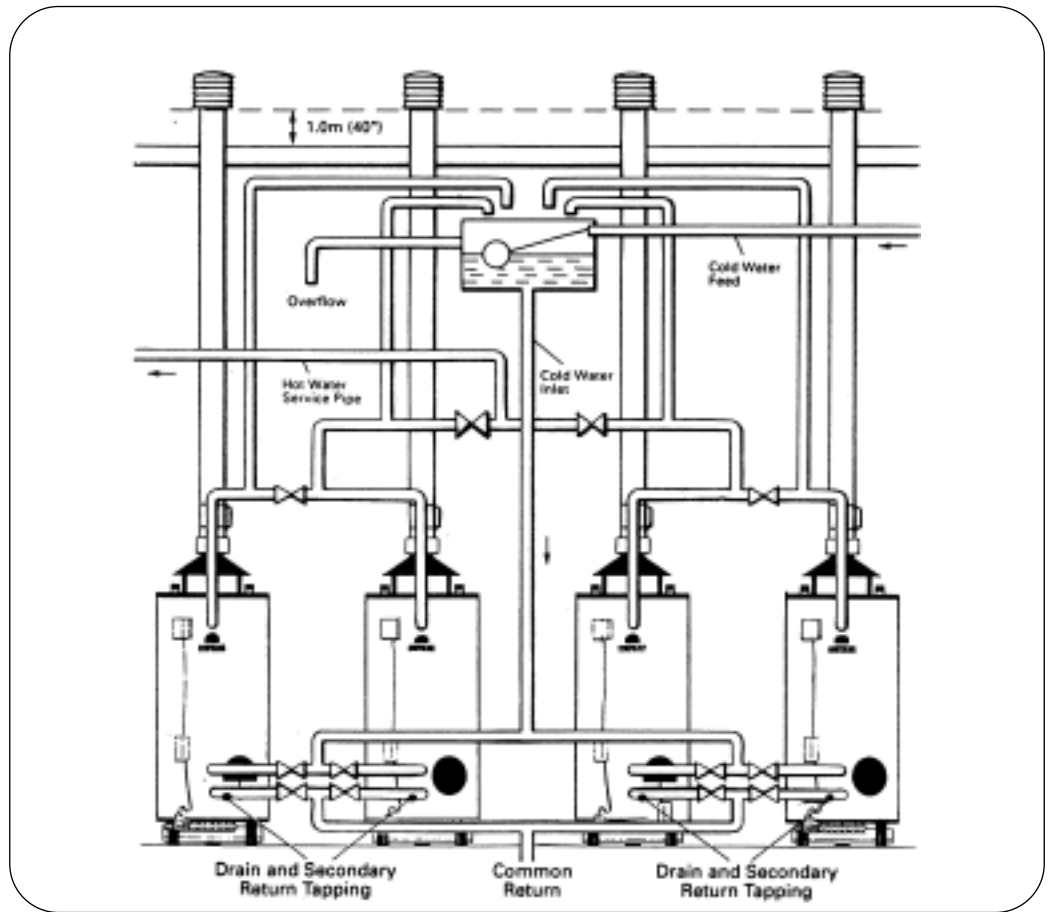

Fig 14.

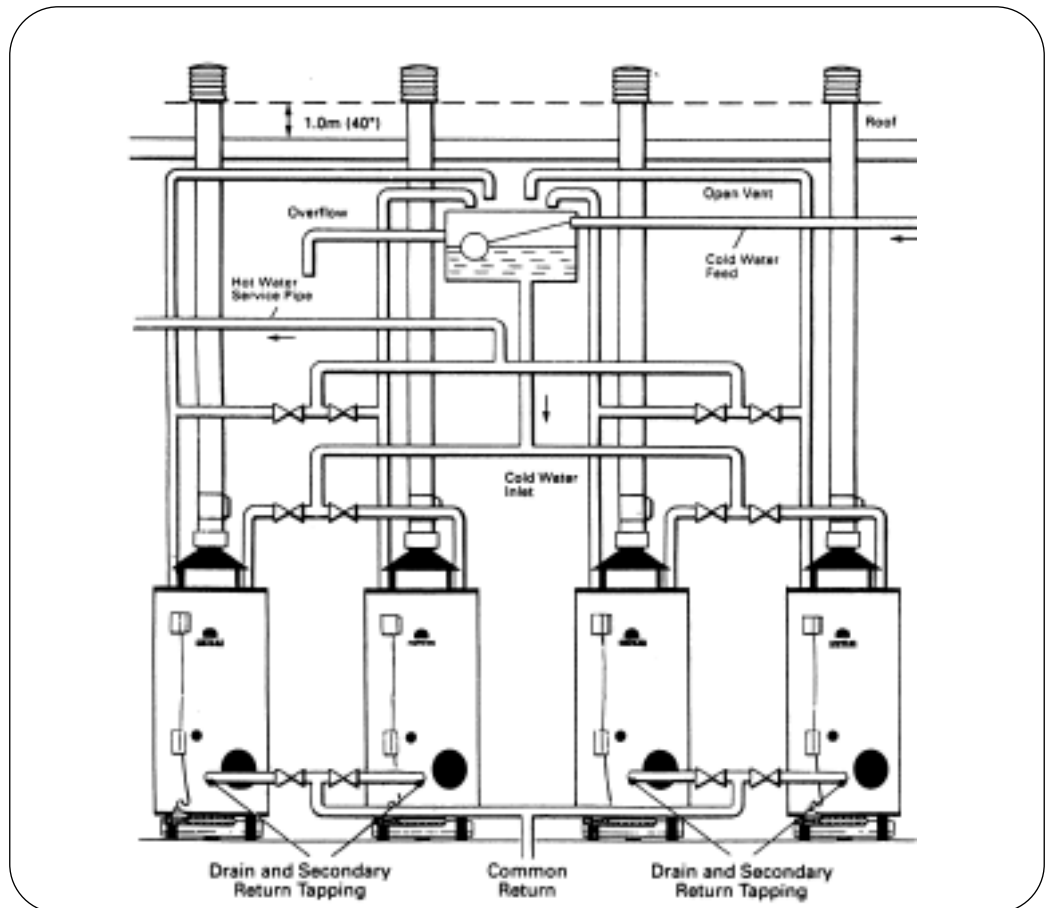

Fig 15.

UNVENTED SYSTEMS, Hi-Flo RANGE

Unvented Systems should be fitted by an Approved Installer

When used in an unvented system, the Andrews Water Heater will supply hot water at a pressure of 3.5bar (50.8lbf/in²) provided that this pressure is available at the mains feed. During conditions of no-flow, system pressure may rise to a maximum of 6bar (87lbf/in²) whilst the burner is operating. When testing the system, it is recommended that a maximum test pressure of 8.62bar (125lbf/in²) is employed.

Fig 16.

The heater can be used on unvented hot water storage systems, with the addition of an Unvented Systems Kit, part number B172 available from Andrews Water Heaters. See Parts List Page 49. The Wall Mounting Assembly is available as an optional extra.

WATER CONNECTIONS

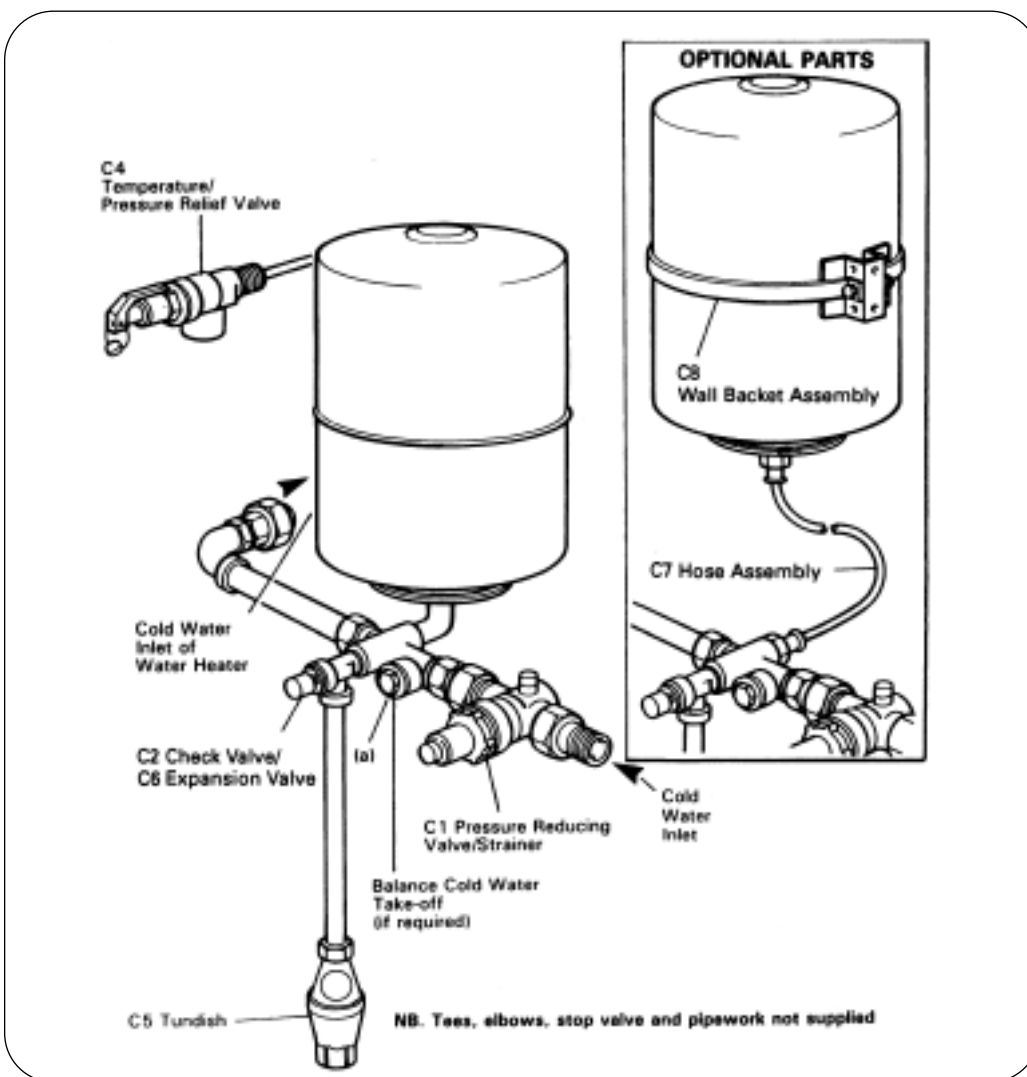

Fig 16.

Item C4 must be fitted into the temperature relief port in the water heater tank.

When assembling items C1 and C2, ensure that the flow arrows marked on the components are pointing in the direction of flow i.e. towards the water heater.

The cold water for services may be drawn from the 22mm compression port on item C1 (a). The water pressure at this point will be similar to that available at the hot water outlet of the water heater. If port (a) is not used, it should be sealed with the blanking plug supplied.

WATER CONNECTIONS

If higher flow rates are required for the cold water services, a suitable tee fitting should be fitted to the pipework, upstream of item C1.

The pipework fitted to the tundish outlet should be at least 28mm diameter and should be terminated at a suitable drain (see Building Regulations 1992 Approved Document G3).

All fittings and materials must be suitable for use with drinking water and listed in the current Water Research Centre "Materials and Fittings Directory".

Installation of unvented hot storage water systems must comply with Part G of the Building Regulations 1992.

Typical water service layout for Hi-Flo Range single heater unvented system is shown in Fig 17.

Typical water service layouts for Hi-Flo Range multiple heater unvented systems are shown in Figs 18 and 19.

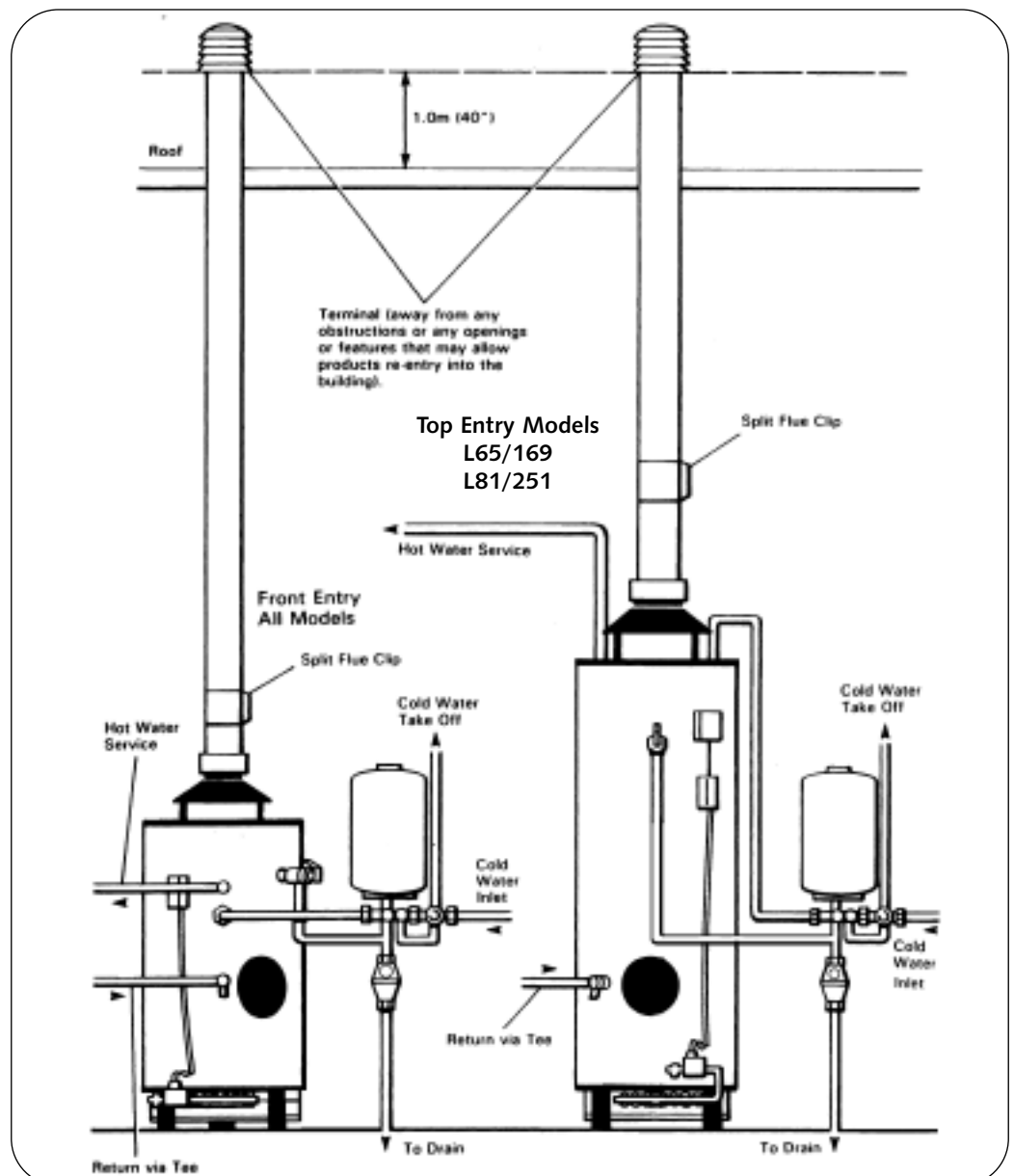

Fig 17.

WATER CONNECTIONS

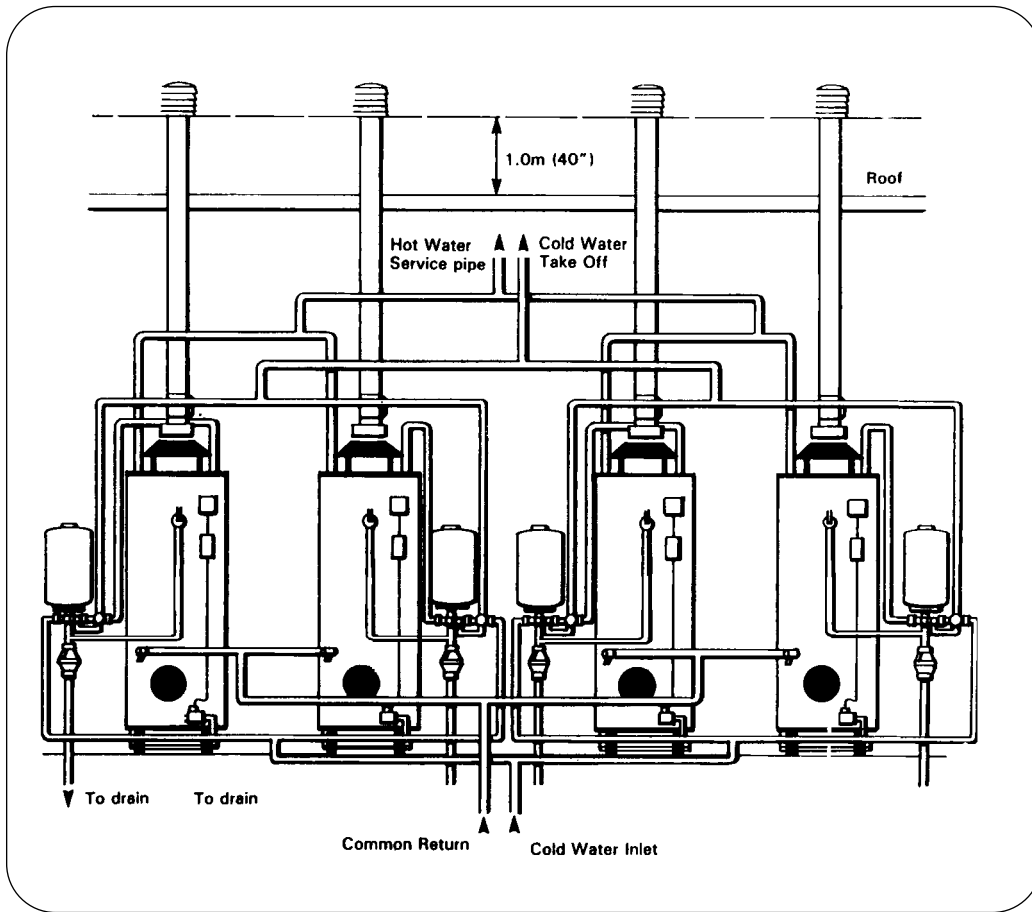

Fig 18.

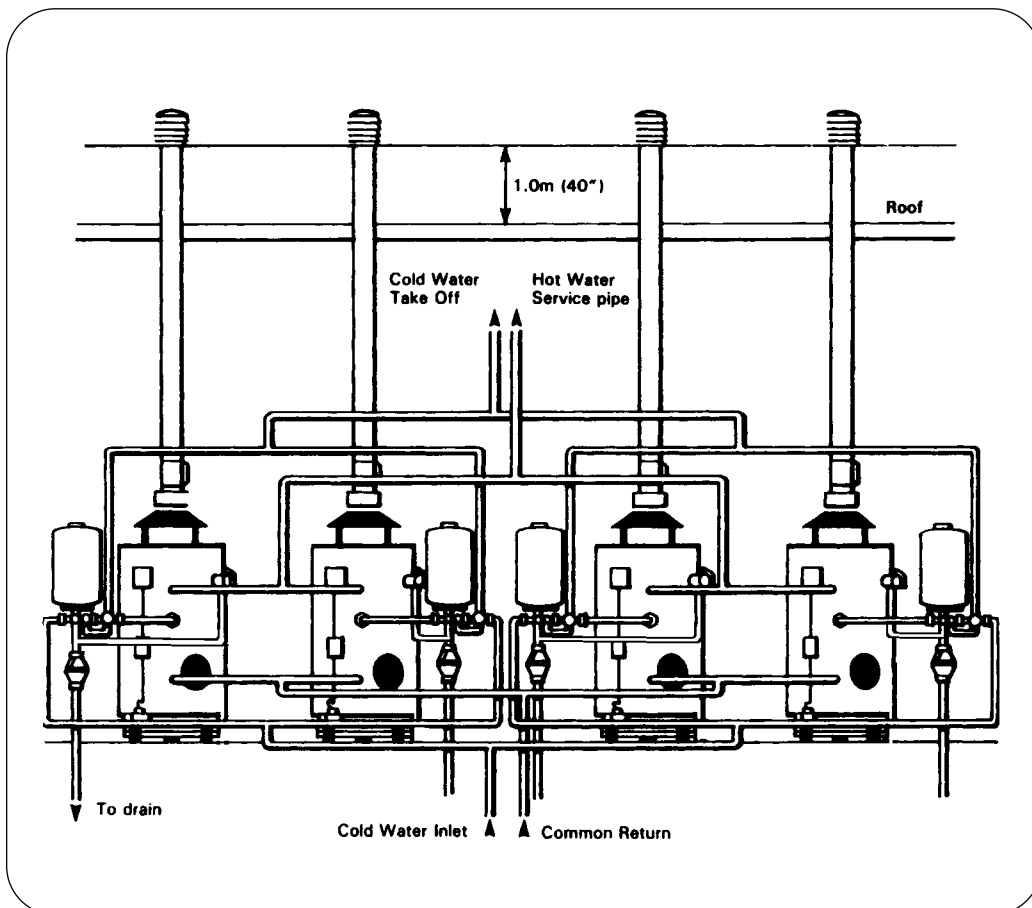

Fig 19.

**STANDARD
RANGE
PERMANENT
PILOT MODELS**

CAUTION! DO NOT OPERATE THE WATER HEATER UNTIL THE STORAGE VESSEL IS COMPLETELY FILLED WITH WATER, WITH WATER RUNNING FROM ALL HOT TAPS.

Open the main gas supply cock after all connections to the gas control are completed and test all connections, using proprietary leak detection fluid.

Lighting the Burner

1. Remove outer cover and slide inner cover to right. (On L63/71 and L84/74 Models, raise the inspection port cover). Wait for 3 minutes for any unburnt gas to vent.
2. Turn the gas control knob to pilot.
3. Fully depress the RED button and light the pilot burner. With the pilot burner alight, hold the red button in for 20 seconds. When the red button is released, the pilot should remain lit. If not, wait for 3 minutes then repeat this operation.
4. Close and refit covers.
5. Set temperature indication dial to required temperature as follows:

Setting	1	2	3	4
Approx. Water Temperature	105°F (41°C)	120°F (49°C)	135°F (57°C)	150°F (66°C)

6. Turn the gas control knob to ON and the burner should light. If not, WAIT FOR AT LEAST 3 MINUTES AND REPEAT FROM STEP 1.

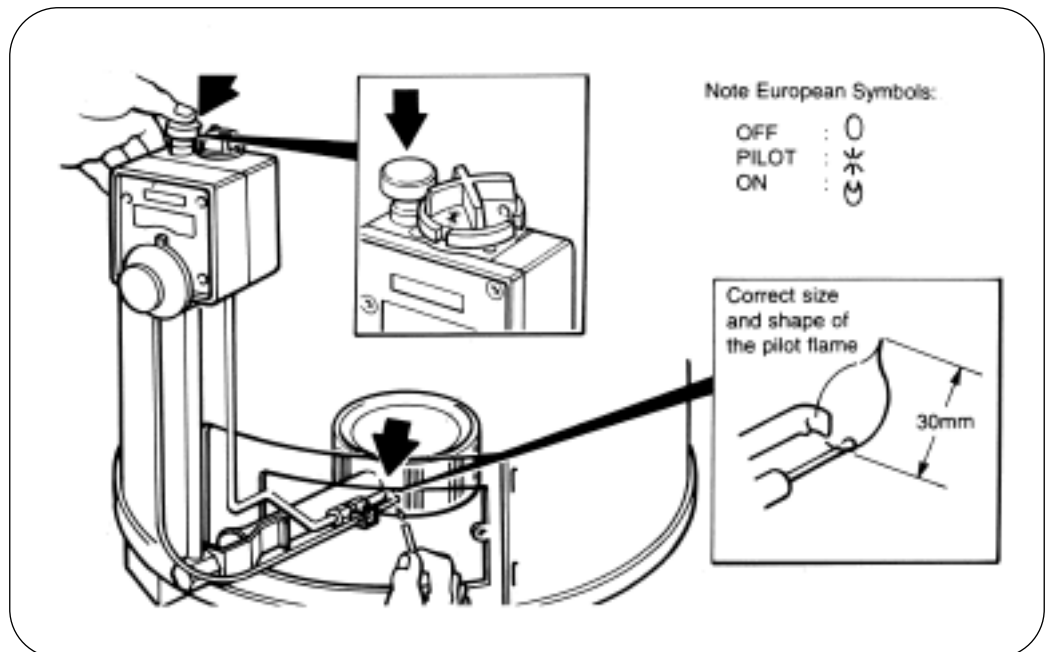

Fig 20.

Shutting Off The Burner

For long periods only (7 days or more) turn gas control knob to PILOT, depress slightly and turn clockwise to OFF. Turn off the gas service cock. For shorter periods, leave the heater under thermostat control.

NOTE! If the pilot goes out for any reason, turn off heater and wait for 3 minutes before relighting.

Checking Main Burner Pressure

1. Turn burner OFF as above.
2. Release bleed screw A one turn and connect pressure gauge tube.
3. Light burner as described above.
4. By means of the external in-line regulator, set burner pressure for gas being used in accordance with the data plate.
5. Remove pressure gauge tube and tighten bleed screw.
6. Leak test using leak detection fluid.

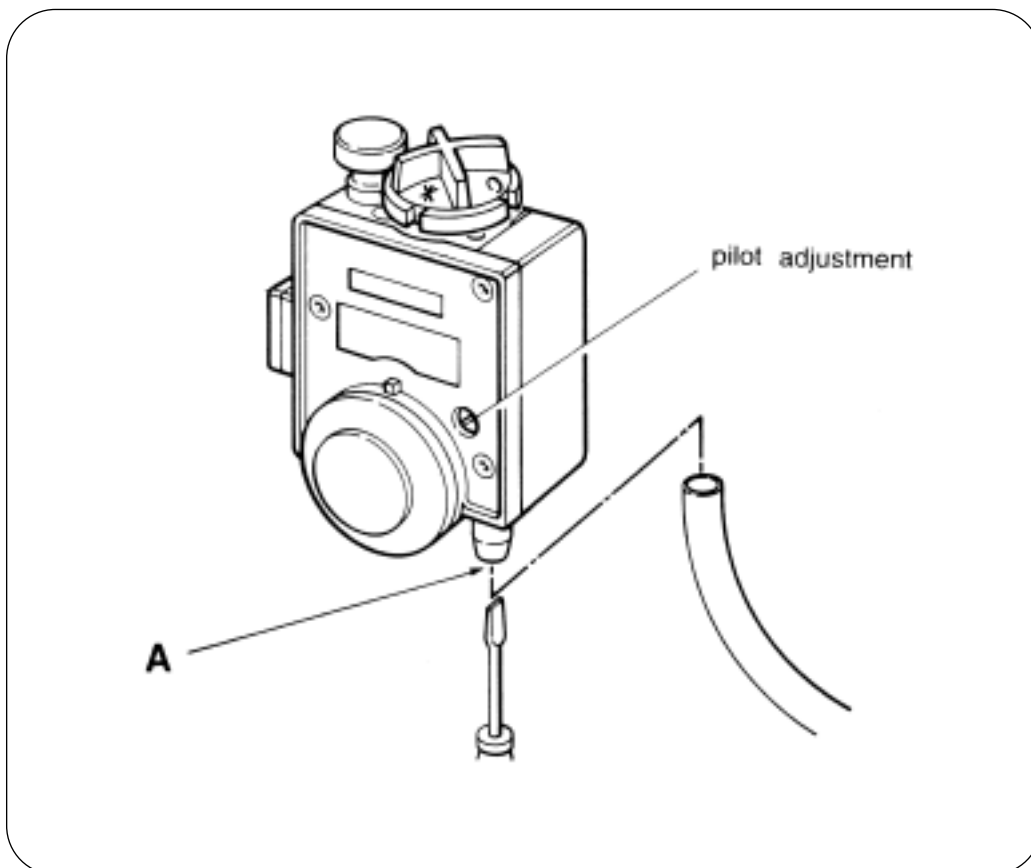

Fig 21.

HI-FLO RANGE**Lighting the Burner**

Open the main gas supply cock after all connections to the gas control are completed and using a manometer, test all connections up to the gas control inlet. Purge air from pipework and ensure there are no loose connections to burner or pilot pipe.

1. Ensure gas supply is on.
2. Turn gas control knob to PILOT position.
3. Depress knob and activate piezo igniter.
4. Keep knob pressed in for a further 40 seconds after pilot lights, then release knob and check that pilot remains lit. If not, turn off then wait 3 minutes before repeating from step 2. Observe via the view port.
5. Turn control knob to ON and turn control thermostat dial to required water temperature. The burner will now light.
6. Check pilot and gas connections for soundness with leak detection fluid whilst burner is alight. Turn off, seal any leakages, then re-test.

WARNING! if pilot goes out, do not attempt to relight gas until at least 3 minutes have elapsed.

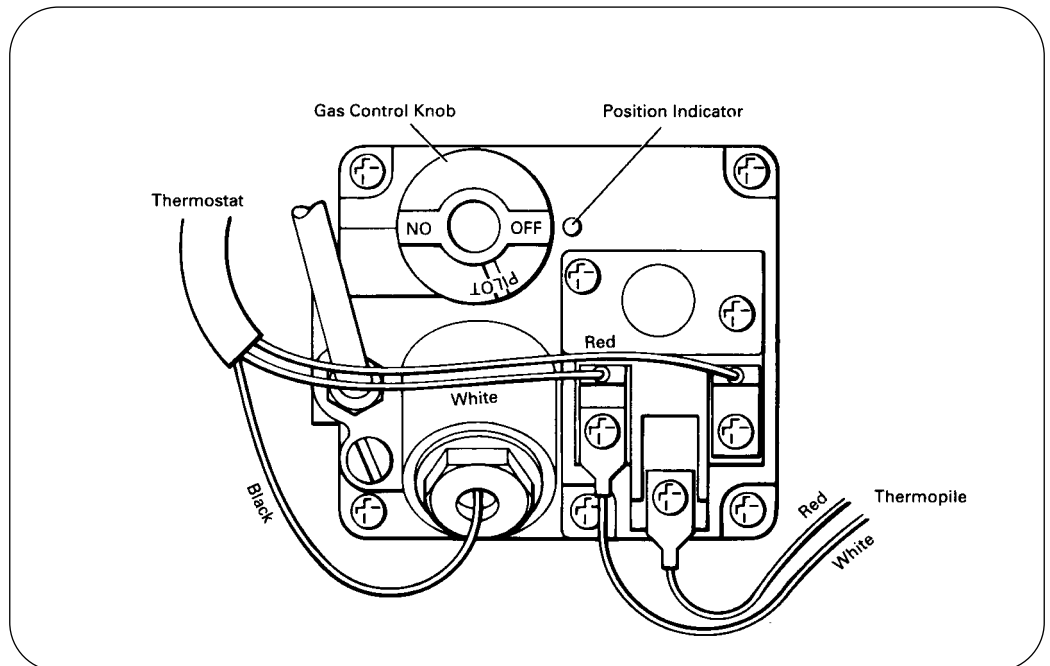

Fig 22.

Shutting Off The Burner

For long periods only, (7 days or more) turn control knob to PILOT, partially depress knob, then turn clockwise to OFF. Turn off gas service cock. For shorter periods leave heater under thermostat control.

Checking Incoming Gas Pressure

1. Turn gas control knob clockwise to OFF.
2. Release bleed screw A and connect pressure gauge tube.
3. Light burner as described above.
4. With the main burner running, the incoming gas pressure must be as follows:

PROPANE	37 mbar (14.86 in W.g.)
BUTANE	28 mbar (11.26 in W.g.)

The service governor should be adjusted if necessary to give the above values.

5. Turn the gas control to OFF, remove the pressure gauge, tighten the bleed screw and check for gas leaks using a leak detection fluid.

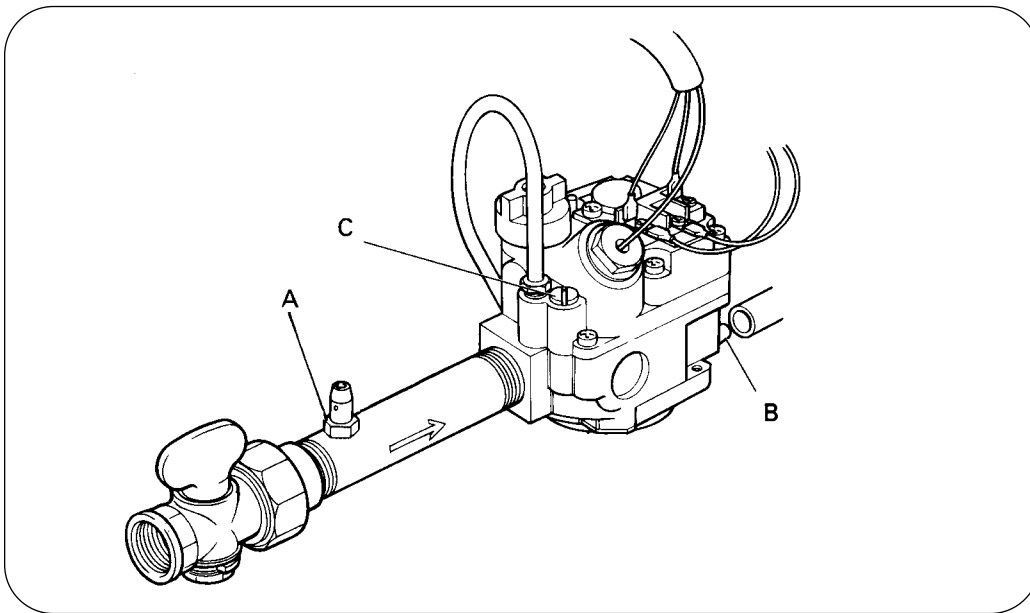

Fig 23.

Checking Main Burner Pressure

1. Turn gas control knob clockwise to OFF.
2. Release bleed screw A and connect pressure gauge tube.
3. Light burner as described above.
4. With the main burner running, check that the burner pressure is as stated on the data plate and in Section 2, Technical Data.
5. Turn the main gas control knob to OFF, remove the pressure gauge, tighten the bleed screw and test for gas leaks (when the burner is re-lit) with a leak detection fluid.

Checking Correct Shape and Size of Pilot Flame

No adjustment is provided for the pilot. The restrictor (C) of the multifunctional control should be fully open (turned fully anti-clockwise).

When viewed from the front of the heater, the pilot flame should appear as shown in Fig. 24.

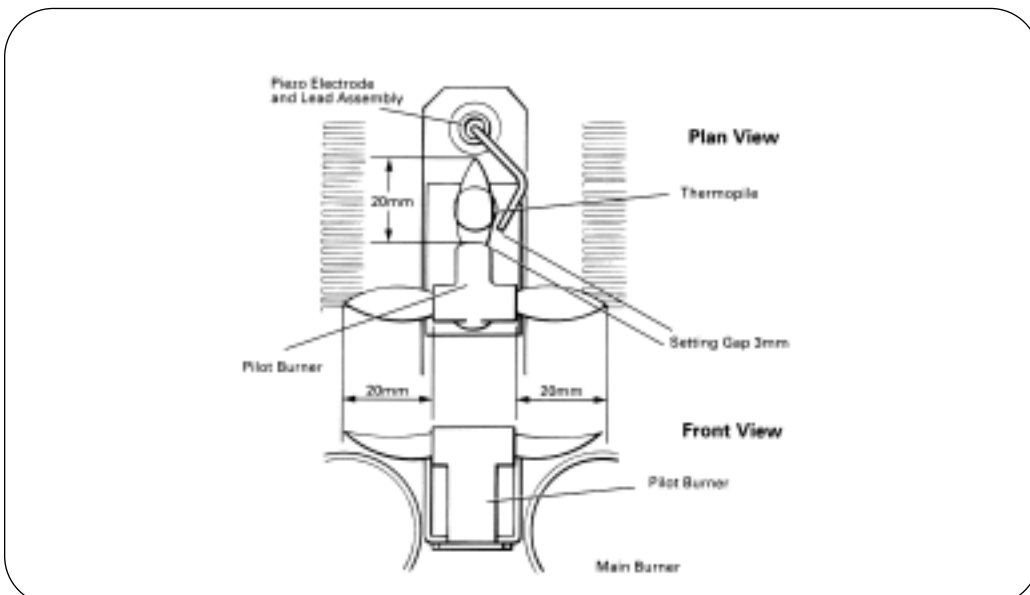

Fig 24.

**STANDARD
RANGE
AUTO IGNITION
MODELS**

Lighting the burner

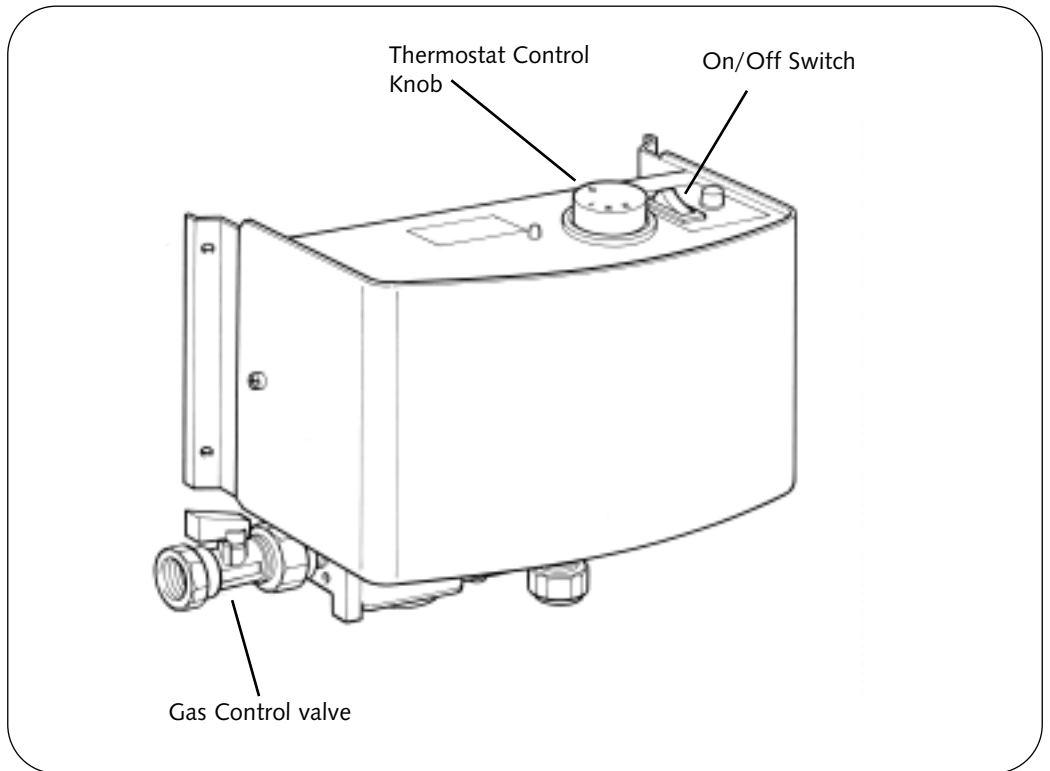

Fig 25.

1. Ensure gas supply is on.
2. Set thermostat control knob to the required water temperature. (See below).
3. Ensure time switch if fitted is in the ON position.
4. Move electrical ON/OFF switch to ON and the burner will light.
5. Check pilot and main gas connections at gas control valve using leak detection fluid whilst burner is alight. Turn OFF, seal any leakages then re-test.

Shutting OFF burner

To shut OFF the burner move switch to OFF then turn OFF the gas service cock.

The water heater should only be turned OFF for long periods, eg holidays, or in an emergency. Otherwise the heater should be left to operate under normal thermostat control.

NB. When using a time control ensure the heater is not turned OFF before the final water draw off occurs. This will ensure the water in the tank is left in a hot condition.

THERMOSTAT SETTING	1		2		3	
APPROX WATER TEMP.	104°F	40°C	131°F	55°C	158°F	70°C

Checking main burner pressure

1. Turn gas supply OFF.
2. Release bleed screw A one turn and connect pressure gauge tube.
3. Light burner as described above.
4. By means of the external in-line regulator, set burner pressure for gas being used in accordance with the data plate.
5. Remove pressure gauge tube and tighten bleed screw.
6. Leak test using leak detection fluid.

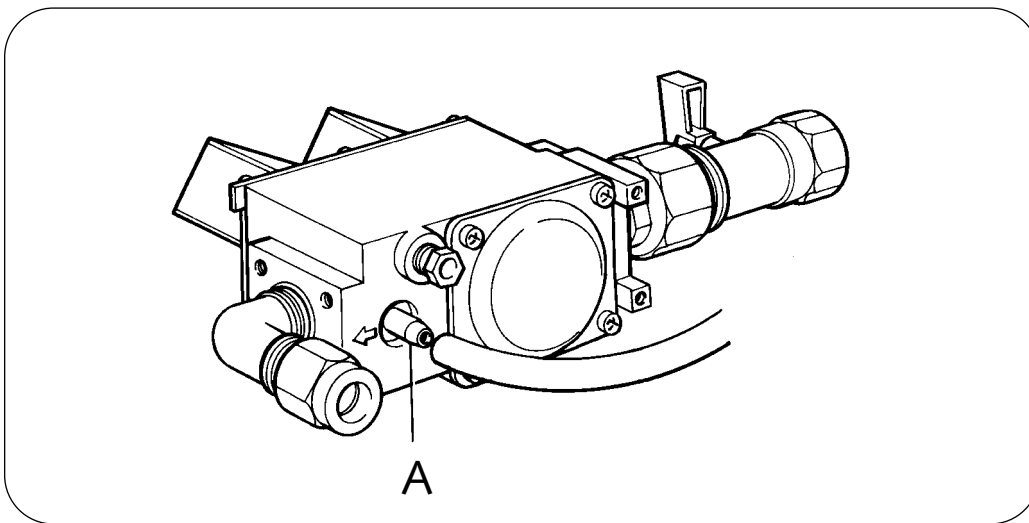
**Fig 24.****Checking for Spillage at the Draught Diverter**

If an extract fan is fitted, (see Air Supply and Ventilation) carry out a spillage check as set out in BS 5440 Part 1, Appendix B. If spillage does occur, increase the ventilation area until the products clear well. If an openable window is in the boiler house or room containing the heater(s), turn on the extract fan and heater(s). Open the window fully, and, using a stiff card, gradually reduce the opening until the appliance(s) just spills. Then increase the opening until the products clear well. Measure the opening for the additional area required.

ALL STANDARD AND HI FLO MODELS

When satisfactory commissioning and testing has been achieved, hand this manual to the User or Purchaser and explain the method of economic and efficient operation.

Explain that:

1. Other than for long shutdown periods, the heater must be left operating normally.
2. It is important that the control thermostat is set at the lowest temperature consistent with the user's needs.

Ensure that the user or purchaser is fully conversant with the lighting, shutdown and general operating procedures, including the emergency procedure. (See p.32).

Advise that any air vents must be kept clear and items must not be placed or stored in the vicinity of the heater.

Advise of precautions necessary to prevent damage to the heater and systems in the event of the system remaining inoperative during frost conditions.

Advise the user or purchaser that for continued efficient and safe operation of the heater, it is important that magnesium anodes are inspected annually and that adequate servicing is carried out at regular intervals by the installer or by the local gas authority.

STANDARD RANGE**HI-FLO RANGE****ALL MODELS****INSTRUCTING THE USER**

**USERS
SAFETY GUIDE**

For your safety read before lighting the appliance

WARNING

1. Always follow manufacturers instructions when lighting the appliance. Failure to do so may result in damage to property, personal injury or loss of life.
2. Before lighting check all round the appliance area for gas. Be sure to check at low level because some gas (i.e. LPG) is heavier than air and will settle on the floor.
3. Do not make any attempt to re-light the appliance if the main burner has extinguished. Wait at least 5 minutes to allow for any unburnt gas to disperse. Ventilate the area if possible.

FOR YOUR SAFETY IF YOU SMELL GAS

1. Turn off gas supply and open windows.
2. Do not operate electrical switches.
3. Extinguish any naked flames.
4. Contact gas supplier if the smell of gas persists.

FOR YOUR SAFETY

Do not store or use petrol, aerosol or other flammable vapours or liquids in the vicinity of this or any other atmospheric gas appliance.

WARNING

Hotter water increases the risk of scalding. Before changing the temperature refer to instruction manual or data label. Hot water can produce third-degree burns in:
6 seconds at 140°F (60°C)
30 seconds at 130°F (54°C)

When properly installed and adjusted, the heater will require minimal attention. Should it become necessary to completely drain the heater, close the cold water inlet valve and open a hot water tap to allow air to enter the system. Fit a suitable hose to the drain cock and open.

Whenever the heater is filled with cold water, condensation will form on the storage vessel surfaces when the burner is lit. This is normal and will disappear when the heater warms up.

The gas control fitted to the heater has a built-in limit thermostat (ECO). In the event of high water temperature, the gas supply will be shut off automatically. The high temperature condition must be identified and rectified before the heater can be relit. A replacement gas control valve must be an identical model with the same code number Robertshaw R110RTS.

Auto-Ignition Unit, Operating Sequence. Standard Range

1. When the control thermostat senses too-cool water, a signal is sent to the control sequence unit.
2. Gas is allowed to pass to the pilot and simultaneous ignition begins.
3. When the pilot flame is established, the main gas solenoid is allowed to slowly open and the main burners or burner is lit.
4. When the control thermostat is satisfied, both pilot and main gas solenoids are closed.

Operating Sequence

1. With the pilot lit, the solenoid coil holds the inlet gas port on the gas valve open.
2. The knob on the gas valve is set to the ON position.
3. The control thermostat is set to the desired water temperature, 49°C to 82°C (120°F to 180°F). To set the thermostat, remove the outer cover and turn the adjustment dial to the required temperature.
4. The thermostat should now be in a closed position allowing the current generated by the pilot-energised thermopile to open the main burner valve.
5. The gas valve has a slow burning feature. Burners will light several seconds after setting the thermostat.
6. Burners will continue to heat water until the preset temperature is reached. As the thermostat opens, the thermopile current is interrupted and the main gas valve will close.

ECO (Energy Cut-Off)

The heater is equipped with an ECO (Energy Cut-Off) device, fitted to the control thermostat. This is a temperature sensitive switch which opens at high temperature, shutting off gas to the burners, including the pilot in an overheat condition. If the pilot goes out and is associated with high water temperature, the ECO is probably operational and the cause of overheating should be investigated.

Temperature Stratification (Stacking)

When small amounts of hot water are drawn repeatedly, the thermostat responds to each feed of cold water and activates the main burners. Each time this occurs, more heat may be put back in the tank than was drawn off. As this continues, water in the upper level of the tank gets hotter than the thermostat setting. This hotter water does not mix completely with the cold inlet water but rises in a 'chimney effect' to the top of the tank. Many repetitions of this over a short time period result in accumulation of excessively hot water in the upper part of the tank, even when the thermostat control is within limits. This is known as stacking.

To counter this condition, an upper thermostat phial is fitted (not on Model L32/143) which senses abnormally hot water and shuts down the main burner until the water cools.

Most modern commercial pipe installations include a circulating pump which keeps hot water moving continuously throughout the heater. This stabilises temperatures in the water heater tank and throughout the pipe system.

**STANDARD
RANGE
FOR AUTO
IGNITION SEE
BELOW**

HI-FLO RANGE

INTRODUCTION**Servicing must be carried out by a properly qualified person**

Whilst giving these instructions for the care of the Heater, it is recommended that checks are carried out by the installer or local gas authority, at least annually. Ensure good ventilation by keeping the heater free of extraneous materials and clear of dust and lint. Keep pipework, flue and tops of heaters clear of any combustible materials. A water softener or lime inhibitor should be employed in hard water areas. The heater should be inspected every few months via the hand hole cleanout and lime or silt deposits removed. Failure to do so will shorten heater life and may invalidate the warranty.

NOTE! The cleanout hole gasket must be renewed whenever the cover is removed.

PRE-SERVICE OPERATIONS**Before servicing, carry out the following operations.**

- 1) Turn off the gas service cock.
- 2) Turn off the cold water supply to the heater.
- 3) Turn on the hot water draw-off taps served by the water heater, or, for multiple installations, turn off the hot water outlet connection valve and secondary return valve.
- 4) Drain down using the drain valve on the heater.

BURNER ASSEMBLY STANDARD RANGE**The burner assembly should be checked and cleaned annually.**

1. Depress catch under the gas control knob and turn to OFF. Remove outer burner cover and slide inner door to right. On L63/71 and L84/74 models, the inner cover must be lifted out.
2. Disconnect pilot tube, thermocouple and main burner supply tube from bottom of control valve. Withdraw burner assembly from heater.
3. Remove screw securing pilot assembly to main burner supply tube.
4. Remove gland nut securing pilot tube to pilot assembly. Withdraw pilot tube and remove pilot restrictor. Clean pilot restrictor with acetone and blow through pilot burner with compressed air.
5. Remove main burner pipe locknut and remove the pipe. Remove main jet and clean with acetone. Blow through main burner with compressed air. **CLEAN ORIFICES WITH WOOD SPLINTER. DO NOT USE SHARP METALLIC OBJECTS.**
6. Re-assemble in reverse order of steps 2 - 5, but note: **DO NOT OVERTIGHTEN THE THERMOCOUPLE CONNECTION. SCREW IN FINGER TIGHT THEN TIGHTEN A FURTHER 1/4 TURN USING A SPANNER.**
7. Turn gas control knob to PILOT and depress. Using leak detection fluid, check joints at both ends of the pilot supply tube. Seal if necessary. **DO NOT EXAMINE WITH A NAKED FLAME.**
8. Allow 3 minutes for unburned gas to disperse. Light the pilot and check flame is correct. (see Section 4, Commissioning). Slide inner door to left (replace on Models L63/71 and L84/74) and turn gas control knob to ON. The main burner will light.
9. Check main burner connection tube at control valve with leak detection fluid and seal if necessary. Replace outer cover.

The burner assembly should be checked and cleaned annually.

NOTE! Models L62/309 and L54/399 are fitted with an anchor bracket between the burner manifold and heater body. Take out 2 screws to remove.

1. Turn gas control valve knob to OFF and disconnect union joint from gas service cock.
2. Disconnect thermostat connections (black, red and white wires) from gas control valve.
3. Remove two screws and slide out burner assembly.
4. Disconnect pilot tube and thermopile connections from gas valve. Remove two screws and withdraw pilot/thermopile assembly.
5. Unscrew two wing nuts and remove draught shield. Remove four screws and disconnect manifold from burner tray.
6. Clean burners by brushing internally and externally and by blowing through with compressed air. Do not remove individual burners from the burner tray.
7. Remove the burner and pilot injectors and clean with acetone. CLEAN ORIFICES WITH WOOD SPLINTER. DO NOT USE SHARP METALLIC OBJECTS.
8. Re-assemble in reverse order but note:
 - i) The flueways and combustion chamber must be cleaned first.
 - ii) Use an approved jointing compound when re-fitting burner injectors.
9. Light heater in accordance with lighting instructions. All gas joints must be checked using leak detection fluid. Turn off and seal any leakages. DO NOT EXAMINE WITH A NAKED FLAME.
10. Re-light the heater and set the thermostat to the user's requirements.

The gas control valve should be checked and service by a qualified person, fully conversant with this item.

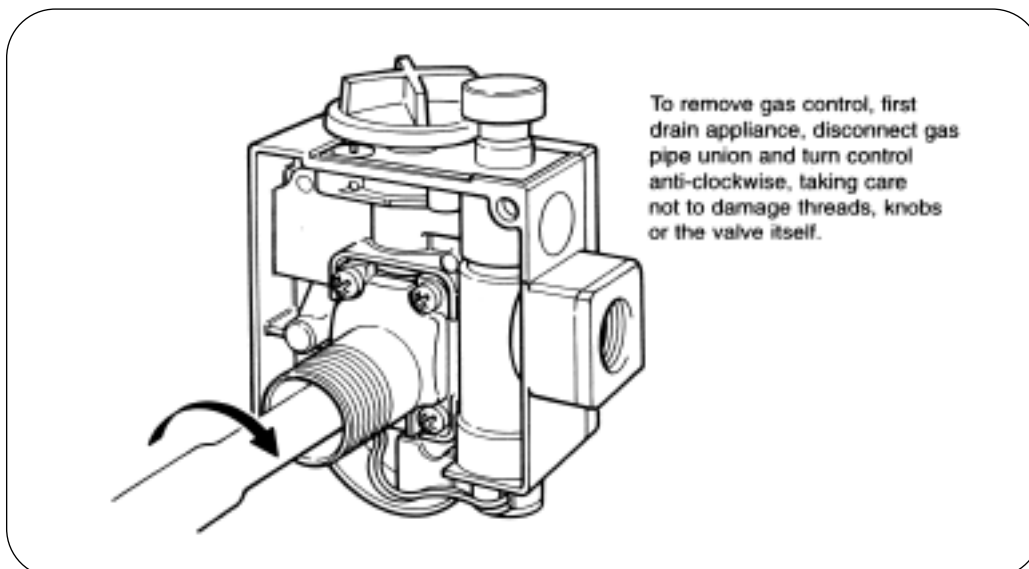

The gas control valve should be cleaned and checked. Remove any debris from the valve inlet filter using a soft brush or by blowing with low pressure air.

After servicing, check:-

1. Soundness of any gas joints broken or disturbed and seal any leaks.
2. Burner pressure/gas rate at maximum thermostat setting.
3. Operation of heater is correct. Reset controls to user's requirements.

BURNER ASSEMBLY
HI-FLO RANGE

GAS CONTROL VALVE
STANDARD RANGE

Fig 27.

GAS CONTROL VALVE
HI-FLO RANGE

FLUE WAYS STANDARD RANGE

The flue ways should be checked and cleaned annually.

1. Depress catch under control knob and turn to OFF. Remove outer burner cover and slide inner door to right. On L63/71 and L84/74 models, the inner cover must be lifted out.
2. Disconnect burner gas tube, pilot tube and thermocouple at gas control.
3. Remove burner assembly complete with pipes and thermocouple lead.
4. Remove split flue clip from flue and lift off draught diverter.
5. Inspect and clean secondary flue installation as necessary.
6. Lift out baffle from inside central flue way. (not Model L84/74)
7. Clean flue way with a brush and remove deposits from underside of storage vessel and from flue baffle.
6. Re-assemble in reverse order. **IT IS IMPORTANT THAT THE BURNER IS CORRECTLY LOCATED IN THE CENTRE OF THE COMBUSTION CHAMBER. DO NOT OVERTIGHTEN THE THERMOCOUPLE CONNECTION. SCREW IN FINGER TIGHT THEN TIGHTEN A FURTHER 1/4 TURN USING A SPANNER.**
7. Re-light heater and carry out relevant commissioning procedures as detailed in Section 4.

FLUE WAYS HI-FLO RANGE

The flue ways should be checked and cleaned annually.

1. Remove burner as described in Burner Assembly, Hi-Flo Range.
2. Remove the split clamp and raise the flue system to clear the draught diverter socket.
3. Remove securing screws and remove top cover complete with draught diverter and adaptor ring.
4. Remove top insulation and keep safe.
5. Remove flue collector cover.
6. Remove flue baffles and brush flue tube using 75mm diameter brush with minimum length of 1.4m.
7. Remove deposits from tank top and burner compartment. Replace baffles.
8. Re-assemble collector cover, insulation, top cover, flue system and burner assembly.
9. Carry out relevant commissioning procedures as detailed in Section 4.

NOTE! For models L65/169 and L81/251, where top inlet/outlet connections are used, both hot and cold connections must be disconnected before removing the top cover.

CLEANING THE STORAGE VESSEL ALL MODELS

The storage vessel should be checked and cleaned annually.

Scale formation in the base of the vessel may occur, particularly in hard water areas and is normally associated with high usage and high water temperatures. It is characterised by a rumbling noise when the main burner is lit. Scale formation in the base of the vessel will affect the efficiency of the water heater and reduce the life of the storage vessel.

It should be noted that the failure of the storage heater vessel due to scale formation on the base will not be covered by the terms of the warranty.

Any scale formation which cannot be removed by normal means of cleaning should be removed by chemical descaling. See below

DESCALING

When descaling the heater, attention is drawn to the following guidelines.

CAUTION!

DUE TO THE CORROSIVE NATURE OF DESCALING FLUID, IT IS ESSENTIAL THAT SUITABLE PROTECTIVE CLOTHING IS USED AND ADEQUATE VENTILATION AVAILABLE.

1. Turn gas control to OFF and isolate gas supply.
2. Close water inlet valve and drain heater tank.
3. Remove magnesium anode(s). It is recommended that new anode(s) is(are) fitted.
4. Add suitable hydrochloric acid based descale fluid. The requirement is normally 5 litres for Standard Models and 10 litres for Hi-Flo Models, or more dependant on amount of limescale present.
5. After a minimum of one hour, restore gas supply and turn on main gas burner for 2 minutes maximum.
6. Isolate gas supply and drain descale fluid through drain port.
7. Open cold water feed valve and fill heater tank.
8. Drain and flush out heater for 20 minutes minimum.
9. Replace anode(s).
10. Restore gas supply and re-light heater.

IMPORTANT!

Remove Correx anode(s) if fitted and plug off the connections using 3/4" BSP plugs. (Hi-Flo models only). Refit the Correx anode(s) when the descaling operation is complete.

Magnesium sacrificial anode(s) is (are) fitted to the top of the storage vessel. The anode(s) will prevent corrosion of the storage vessel. Anode condition should be checked annually and replaced if excessive wear is present.

1. Withdraw each anode using a 11/16in AF socket spanner. A new anode measures 21mm diameter.
2. An anode should be replaced, if, at any point along its length, the diameter is reduced to half, or less of original. Particular attention should be paid to the ends.
3. If the anode is encrusted with limescale, it should be either wire brushed to reveal bright metal or replaced.

Where Correx™ anodes are fitted, no maintenance is necessary.

Check the condition and operation of the safety valve as described below.

During Servicing

Examine the safety valve for deposits or let-by. Clean or replace as necessary.

When Re-Commissioning

Operate the safety valve, ensuring no let-by when the valve is reset and reseated.

NOTE! For adjustable valves, reduce the rating until the valve operates and gives full flow. Reset the valve and check for let-by. For lever operation valves, operate lever and check for let-by when reseated.

Re-light and carry out commissioning checks as detailed in Section 4, Commissioning. Set the thermostat control to the required user setting.

**MAGNESIUM
ANODE(S)
ALL MODELS****SAFETY
VALVE
HI-FLO RANGE****RESTART
ALL MODELS**

**GAS
CONTROL
VALVE**

NOTE! Models L62/309 and L54/399 are fitted with an anchor bracket between the burner manifold and the heater body. Remove two screws to release the anchor bracket.

1. Turn gas control knob and gas service cock to OFF.
2. Disconnect pilot feed pipe, thermocouple and thermostat leads from gas valve.
3. Disconnect union joint from gas service cock.
4. Unscrew two wing nuts and remove draught shield. Remove four screw located at each end of the burner manifold and withdraw gas control/burner manifold as a unit.
5. Unscrew the control valve from the burner manifold noting position of the parts.
6. Remove gas service cock union from the control valve.
7. Re-assembly is reverse of above. The joints between the gas cock union and the control valve to burner manifold must be made using an approved jointing compound suitable for natural gas. The gas valve must be fitted so that it is square relative to the centre line of the injectors.
8. Re-commission the heater as detailed in Section 4, Commissioning.

Please note that when replacing the gas control valve on heater models L32/143 & L65/169 a restrictor must be fitted at the bottom of the gas valve inlet thread.

**USER-
ADJUSTABLE
CONTROL
THERMOSTAT
WITH LIMIT
SENSOR PHIAL
AND OVERHEAT
ECO**

NOTE! These instructions apply to all models but Model L32/143 is not fitted with a limit sensor phial.

1. Turn off the gas control and the service cock.
2. Drain the heater.
3. Remove front cover from control thermostat.
4. Disconnect black, red and white leads and withdraw.
5. Remove phial guard by removing two screws.
6. Remove the clips locating the thermostat capillary.
7. Unscrew gland nut securing limit phial and pull out the phial.
8. Rotate control thermostat/limit phial unit anti-clockwise using a smooth jawed spanner and withdraw.
9. Re-assembly is reverse of above. The joint between control thermostat and tank must be made using an approved jointing compound.
10. Re-commission the heater as detailed in Section 4, Commissioning.

1. Turn gas control knob and gas service cock to OFF and disconnect union joint on the gas service cock.
2. Remove two wing nuts and remove front draught shield.
3. Disconnect thermopile and pilot supply pipe from gas control valve.
4. Remove two screws and withdraw burner assembly.
5. Remove two screws and withdraw pilot assembly.
6. Unscrew gland nut securing thermopile to its bracket and withdraw.
7. Unscrew pilot feed pipe nut and withdraw pipe. The pilot injector will be left in the pilot burner and may be withdrawn by inverting the burner and allowing it to fall out.
8. Re-assemble pilot assembly and connect pilot pipe only to gas control valve with the pilot assembly outside the heater. Turn on gas service cock. Turn gas control to PILOT and press knob, whilst testing pilot connection at gland nut for soundness with leak detection fluid. Seal any leakages and re-test. Turn gas control valve and service cock to OFF.
9. Re-assembly is reverse of steps 2 to 6.
10. All gas joints must be checked for soundness using leak detection fluid. Turn off and seal any leakages. **DO NOT EXAMINE WITH A NAKED FLAME.**
11. Re-light the heater and set thermostat to user's requirements.

**THERMOPILE/
PILOT
BURNER/PILOT
RESTRICTOR**

NOTE! Models L62/309 and L54/399 are fitted with an anchor bracket between the burner manifold and the heater body. Remove two screws to release the anchor bracket.

1. Turn off the gas control and the service cock. Disconnect union joint on service cock.
2. Remove two wing nuts and remove front draught shield.
3. Disconnect thermostat connections (black, red and white wires) from gas control valve.
4. Remove two screws and slide out burner assembly.
5. Disconnect pilot tube and thermopile connections from gas valve. Remove two screws and withdraw pilot/thermopile assembly.
6. Remove two screws to remove burner manifold and draught shields.
7. Remove two screws and remove burner fixing bracket.
8. Draw burner forwards to clear its rear location slot. Replace with new burner.
9. Re-assembly is the reverse of steps 2 to 7.
10. Light the heater in accordance with the lighting instructions. All gas joints must be checked for soundness using leak detection fluid. Turn off and seal any leakages. **DO NOT EXAMINE WITH A NAKED FLAME.**
11. Re-light the heater and set thermostat to user's requirements.

BURNER

**AUTO IGNITION
UNITS**STANDARD
RANGE

FAULT	ACTION
NO IGNITION AT PILOT	<ul style="list-style-type: none">(a) Check gas service cock is open.(b) Electrical ON/OFF switch is not ON.(c) Power to unit interrupted.(d) Thermostat set too low.(e) Check ECO for failure. Reset.(f) Check for 24V AC at intermittent pilot ignition control terminal No. 1. Replace control if faulty.(g) Faulty Solenoid Coil. Replace if faulty.

**PERMANENT
PILOT MODELS
STANDARD AND
HI-FLO RANGES**

FAULT	ACTION
PILOT LIGHTS BUT MAIN BURNER DOES NOT	<ul style="list-style-type: none"> (a) Check for 24V AC at intermittent pilot ignition control terminal No. 3. Replace control if faulty. (b) Faulty Solenoid Coil. Replace if faulty.
WATER DOES NOT GET HOT	<ul style="list-style-type: none"> (a) Check gas service cock is open. (b) Check water valves are open (c) Check pilot is alight (d) Check thermostat setting. reset to higher temperature (e) Check gas pressures at burner and at gas inlet to appliance. (f) Standard Range. Check cold dip inlet tube for damage.
PILOT FLAME FAILURE	<ul style="list-style-type: none"> (a) Try to light burner. (b) Pilot will not light. Wait 3 minutes then try again. <p>NOTE: If pilot flame has failed and water is over temperature, ECO has operated. In which case, determine cause of overheating.</p>
PILOT WILL NOT STAY ON	<ul style="list-style-type: none"> (a) Check gas is available (b) Check thermopile and ECO connections. Replace if necessary. (c) Check if inlet gas pressure is too high or too low. Pressure to multifunctional control should be 37 mbar (14.86in WG) Propane 28 mBar (11.26in WG) Butane. (d) Pilot jet blocked. Clean or replace pilot jet. (e) Faulty magnet coil. Replace multifunctional control. (f) ECO safety thermostat operating at too low a temperature. Replace faulty control.
BURNER WILL NOT LIGHT PILOT ESTABLISHED	<ul style="list-style-type: none"> (a) Thermostat setting too low. (b) Gas control knob not set to ON. (c) Check thermostat for failure to close. (d) Check gas control valve.

**PERMANENT
PILOT MODELS
STANDARD AND
HI-FLO RANGES**

FAULT	ACTION
THERMOPILE / THERMOCOUPLE BURNS OUT FREQUENTLY	(a) Check pilot connection for loose joints. (b) Check correct ventilation is available. (c) Check flue is clear and is correctly designed and flue terminal is correctly positioned. (d) Check for presence of halogen compounds.
HEATER SOOTING, YELLOW FLAME (POOR COMBUSTION)	(a) Check gas burner pressure and injector size. If possible, check heat input with meter and watch. (b) Clean burners and injectors. (c) Flue obstruction. Clean flue ways. (d) Check flue design and termination position. (e) Check for correct ventilation.
WATER TEMPERATURE TOO HIGH	(a) Reset thermostat to lower temperature. (b) Thermostat faulty. Check and replace if necessary. (c) Main gas valve not closing. Clean or replace.
WATER TEMPERATURE TOO LOW	(a) Reset thermostat to higher temperature. (b) Check gas pressures at burner and at gas inlet to heater. (c) Thermostat faulty. Check and replace if necessary.
NOT ENOUGH HOT WATER	(a) Check gas pressures at burner and at gas inlet to heater. (b) Check amount of water being used against recovery rate given on data plate. If usage too high, more heating capacity needed.
WATER DRIPPING FROM BASE OF HEATER	(a) Check if this stops when water in heater is hot. If yes, then condensation is the problem caused by incorrectly designed flue or by tank cooling excessively, i.e. more hot water being used than recovery rate of heater. If so, more heating capacity needed. (b) If water continues to drip when heater is hot, problem is leaking joint or storage vessel.
RUMBLING NOISE	(a) Scale formation in heater, consult water treatment specialist. Heater must be descaled and suitable water treatment provided to avoid re-occurrence.

**PERMANENT
PILOT MODELS
HI-FLO RANGES**

FAULT	ACTION
--------------	---------------

LOUD WHISTLING
NOISE

Check burner primary air shutter settings are correct to dimensions given below. If not reset to dimensions given below. If the whistling persists continue to reduce the settings until the whistling stops.

Heater Model	Air Shutter Dimension A in mm
L32/143	8
L65/169	5
L81/251	10
L62/309	8
L54/399	8

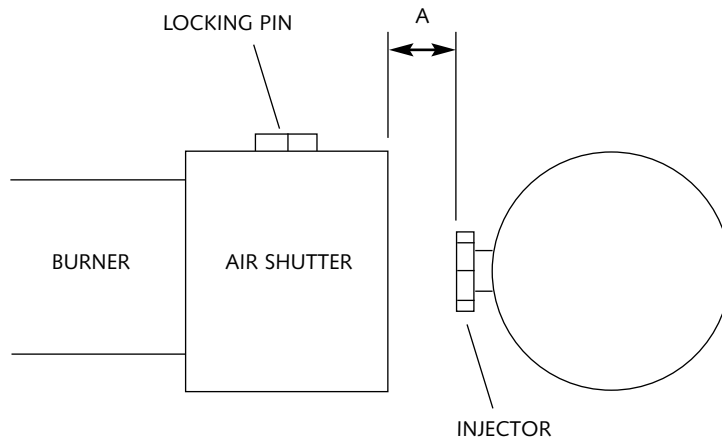

**STANDARD Models
L24/31, L32/35,
L40/36, L63/71**

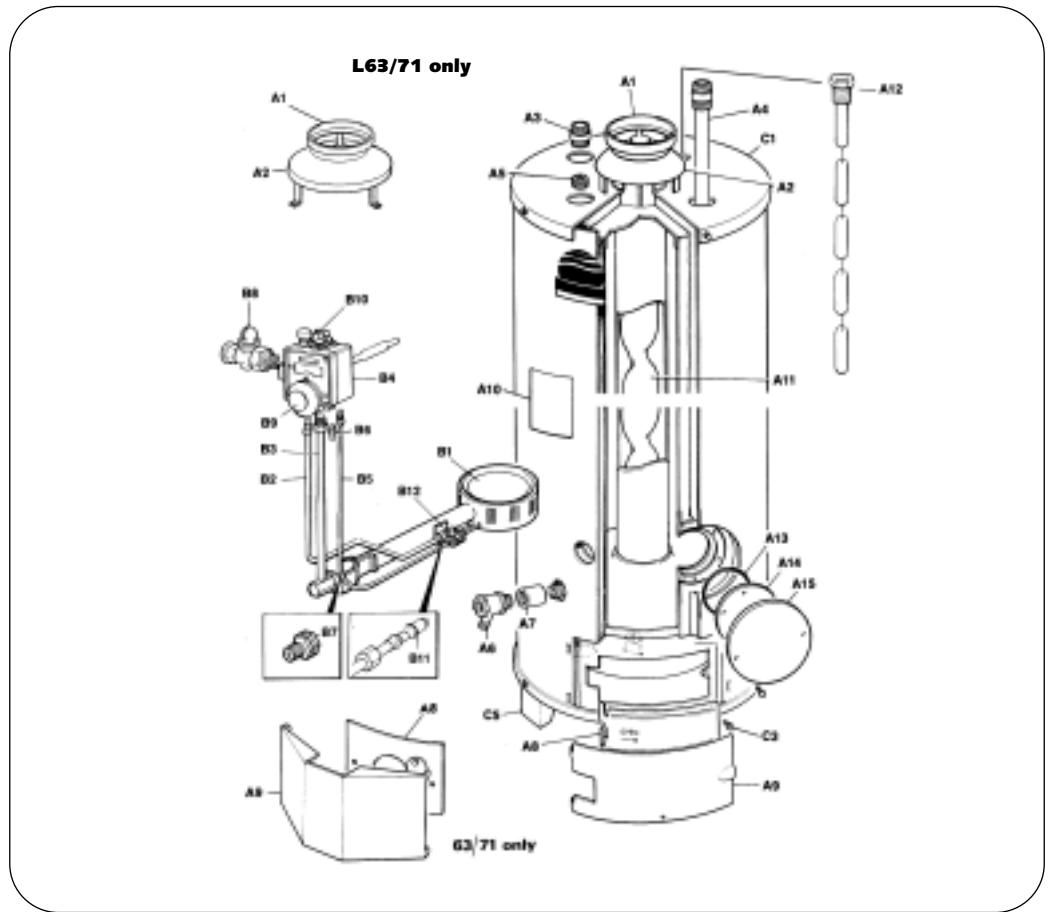

**STANDARD Model
L84/74**

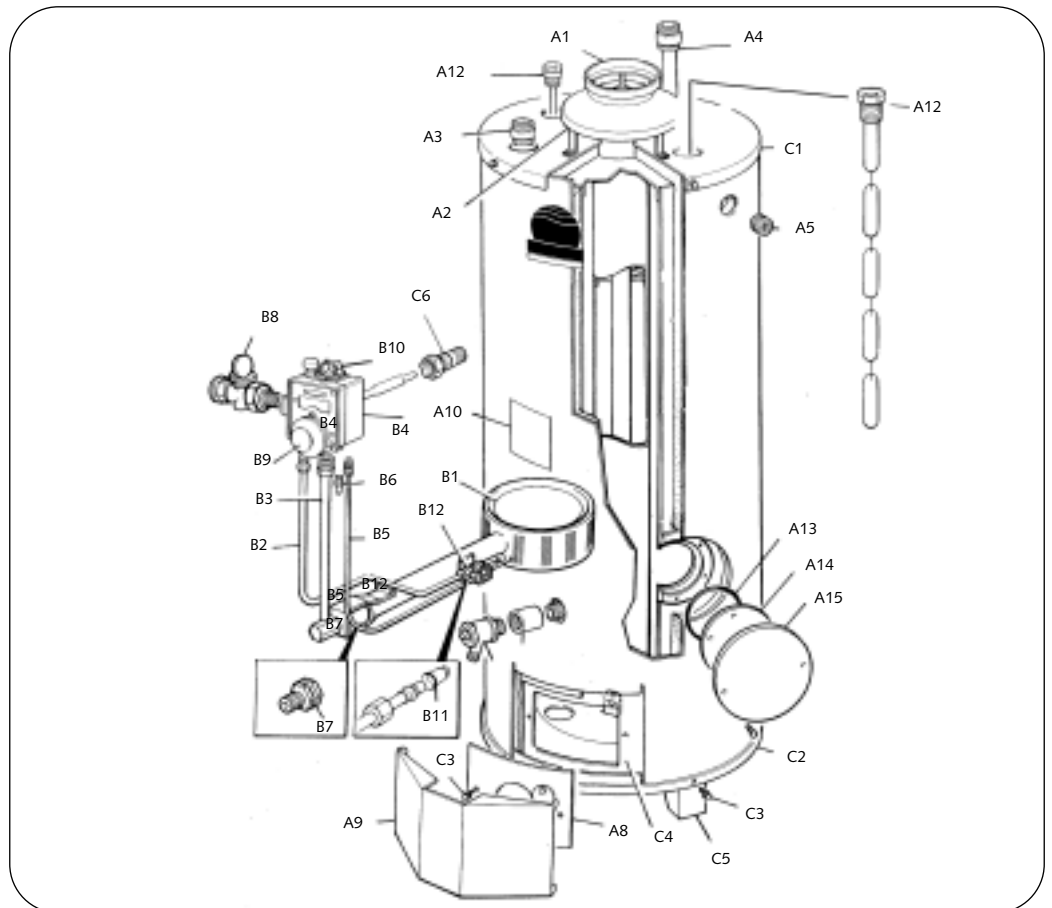

STANDARD MODELS

Model Ref.	L24/31	L32/35	L40/36	L63/71	L84/74	Description	Qty
	Part Numbers						
A1	C654	C654	C654	C657	C657	Adaptor Ring	1
A2	C653	C653	C655	C656	C658	Draught Diverter	1
A3	C285	C285	C285	C285	C690	Hot Outlet Nipple	1
A4	C286	C292	C293	C293	C691	Cold Inlet Dip Tube	1
A5	C641	C641	C641	C641	C641	Plug Return Connection	1
A6	C381	C381	C381	C381	C381	Drain Cock	1
A7	C103	C103	C103	C103	C103	Socket Coupler 3/4"	1
A8	C449	C449	C449	C660	C660	Cover, Combustion Chamber	1
A9	C450	C450	C451	C329	C329	Cover, Burner Access	1
A10	C735	C736	C737	C738	C739	Data Badge	1
A11	C671	C671	C672	C673	-	Flue Baffle	1
A12	C333	C333	C333	C333	-	Service Magnesium Anode	1
A12	-	-	-	-	C333	Service Magnesium Anode	2
A13	N/A	N/A	N/A	C299	C299	Cleanout Pad Seal	1
A14	N/A	N/A	N/A	C300	C300	Cleanout Pad	1
A15	N/A	N/A	N/A	C301	C301	Cleanout Pad Cover	1
B1	C815	C816	C817	C818	C819	Burner Assy. comprising items B2, B3, B5, B7, B12	1
B2	C405	C406	C406	C407	C407	Pilot Supply Pipe	1
B3	C828	C828	C828	C829	C829	Burner Supply Pipe	1
B4	C822	C822	C822	C822	C822	Multifunctional Control	1
B5	C132	C132	C132	C132	C132	Thermocouple	1
B6	C136	C136	C136	C136	C136	Pressure Test Nipple	1
B7	C820	C821	C821	C823	C823	Injector	1
B8	C382	C382	C382	C382	C382	Gas Cock	1
B9	C113	C113	C113	C113	C113	Knob Thermostat Control	1
B10	C114	C114	C114	C114	C114	Knob	1
B11	C316	C316	C316	C316	C316	Pilot Burner Jet Type N11	1
B12	C412	C412	C412	C412	C412	Pilot Burner c/w Jet, Pipe Electrode and Lead	1
C1	C464	C465	C465	C466	C670	Top Cover Outer Jacket	1
C2	C416	C417	C417	C668	B669	Base Assy. c/w Radiation Pan	1
C3	C689	C689	C689	C689	C689	Special Screw	10
C4	C661	C662	C662	C663	C664	Combustion Chamber	1
C5	N/A	N/A	N/A	C689	C698	Leg	3
C6	N/A	N/A	N/A	N/A	C772	Gas Control Extension Nipple	1

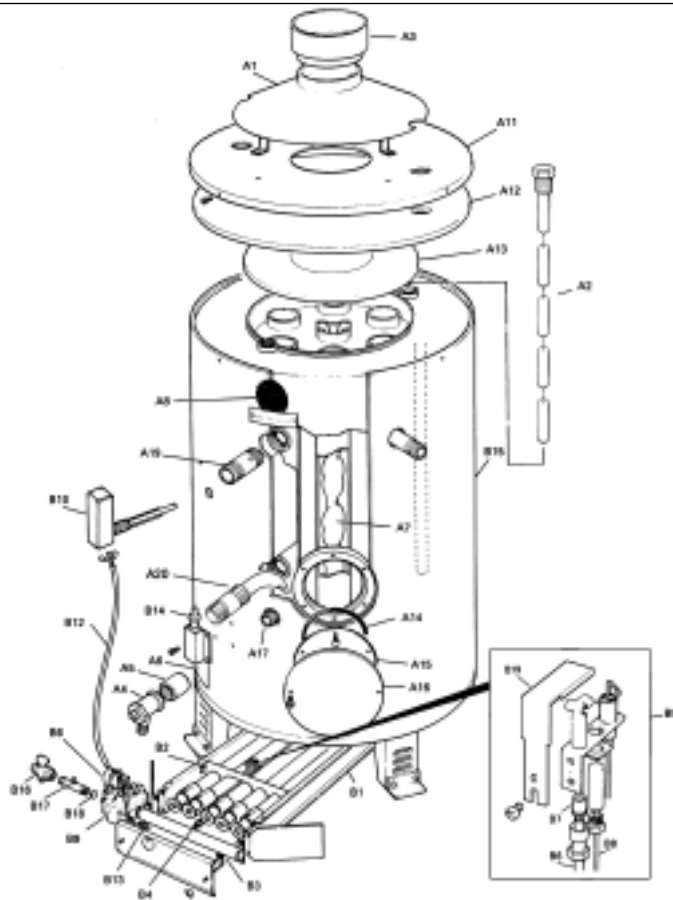

**Hi-Flo Model
L32/143**

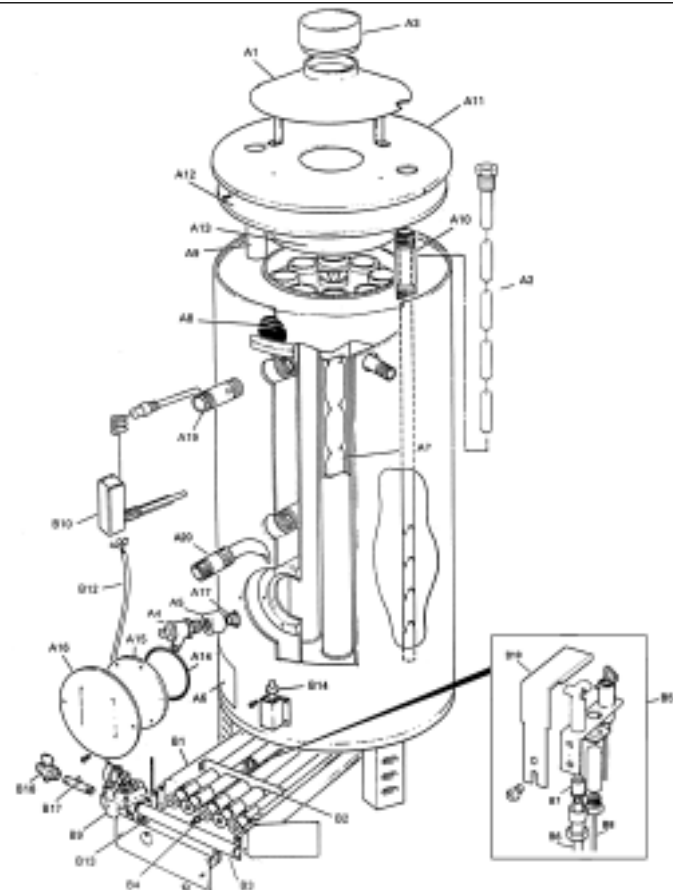

**Hi-Flo Models
L65/169, L81/251**

HI-FLO MODELS

Model	L32/143	L65/169	L81/251		
Ref.	Part Numbers			Description	Qty
A1	E023	C500	C501	Draught Diverter	1
A2	C333	C333	C333	Service Magnesium Anode	2
A3	C334	C334	-	Flue Connector, 150mm, BS 835	1
A3	-	-	C432	Flue Connector, 200mm, BS 835	1
A4	C381	C381	C381	Drain Cock, BS 2879, 3/4"	1
A5	C103	C103	C103	Socket Coupler, 3/4"	1
A6	E022	C494	C495	Data Badge	1
A7	C533	C536	C540	Flue Baffle	8
A8	C235	C235	C235	Andrews Label	1
A9	N/A	C479	C479	Hot Outlet Connection, 1 1/2" BSP	1
A10	N/A	E056	E055	Hydrojet Cold Inlet Connection (top) 1 1/2" BSP	1
A11	C486	C486	C486	Top Cover	1
A12	C488	C488	C488	Insulation Pad	1
A13	E391	C489	C489	Flue Box Top Cover	1
A14	C299	C299	C299	Cleanout Pad Seal	1
A15	C300	C300	C300	Cleanout Pad	1
A16	C301	C301	C301	Cleanout Pad Cover	1
A17	C247	C247	C247	Drain Tapping Connector, 3/4 BSP	1
A19	C534	C534	C534	Nipple, 1 1/2 " BSP	4
A20	E050	E050	E050	Hydrojet Cold Inlet Connection (side) 1 1/2" BSP	1
B1	E032	C565	C566	Burner Assy. comprising items B2 - B6 and B8 - B9	1
B2	C503	C503	C503	Burner Bar	5
B3	C505	C505	C505	Burner Manifold	1
B4	E 018	-	-	Injector 1.6mm	5
B4	-	C570	-	Injector 1.7mm	5
B4	-	-	C571	Injector 1.85mm	
B5	C576	C576	C576	Pilot Assy. c/w injector and electrode	1
B6	C508	C508	C508	Pilot Supply Pipe	1
B7	C316	C316	C316	Pilot Injector	1
B8	C552	C552	C552	Thermopile	1
B9	C575	-	-	Multifunctional Valve	1
B10	C512	-	-	Control Thermostat / Overheat ECO	1
B10	-	C539	C539	Control Thermostat with remote phial and ECO	1
B12	C513	C559	C559	Lead Assy. Thermostat to Gas Valve	1
B13	C136	C136	C136	Pressure Test Nipple	1
B14	C514	C514	C514	Piezo Igniter	1
B16	C498	C498	C498	Gas Cock 3/4" BSP FxF	1
B17	C578	C578	C578	Inlet Nipple 3/4" NPT/3/4" BSP	1
B18	C577	C577	-	Restrictor, Inlet 4.50mm	1
B19	E418	E418	E418	Pilot Shield	1

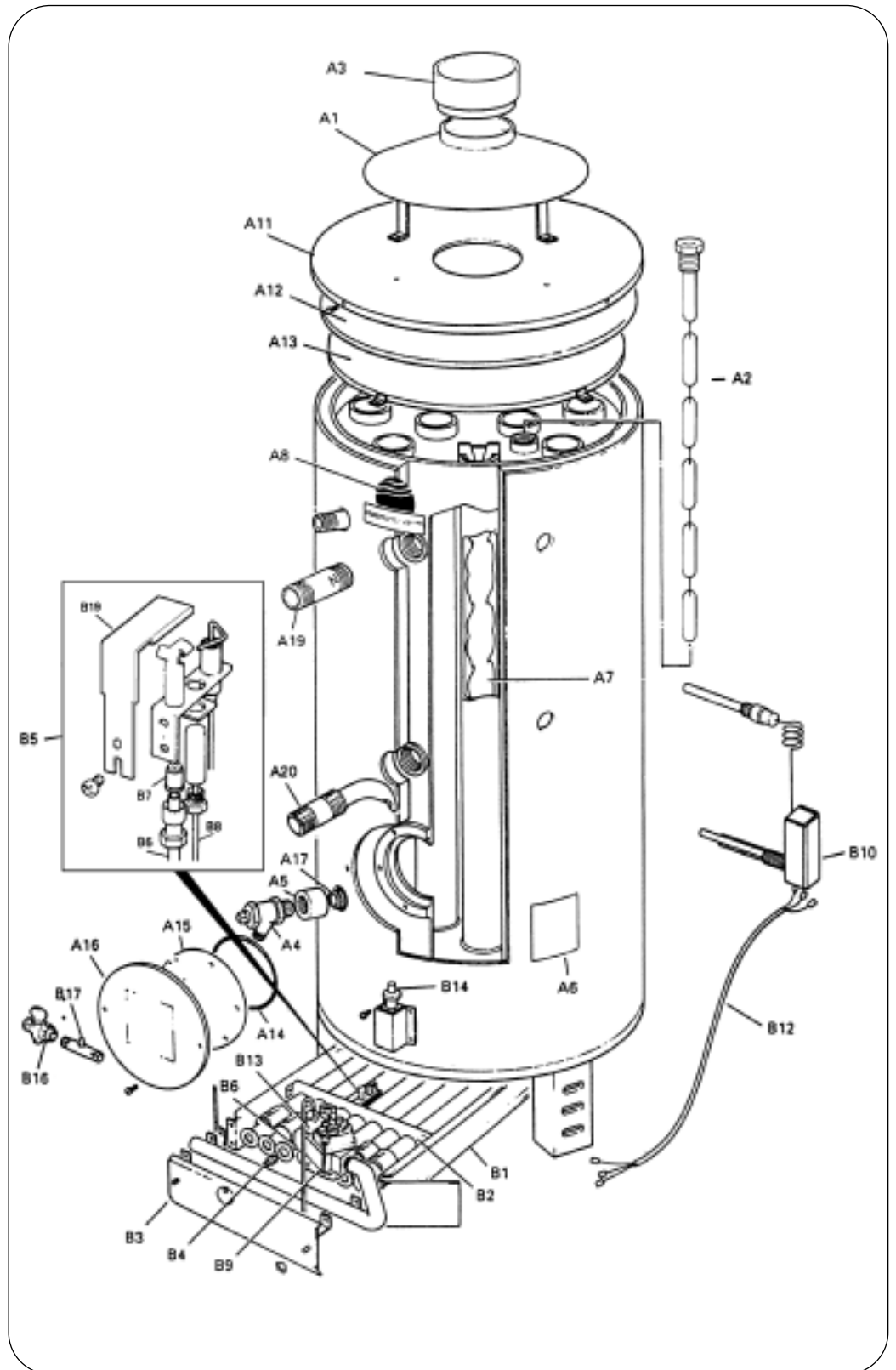

**Hi-Flo Models
L62/309, L54/399**

HI-FLO MODELS

Model	L62/309	L54/399		
Ref.	Part Numbers		Description	Qty
A1	C501	C548	Draught Diverter	1
A2	C333	C333	Service Magnesium Anode	2
A3	C432	-	Flue Connector, 200mm, BS 835	1
A3	-	C335	Flue Connector, 250mm, BS 835	1
A4	C381	C381	Drain Cock, BS 2879, 3/4"	1
A5	C103	C103	Socket Coupler, 3/4"	1
A6	C496	C497	Data Badge	1
A7	C543	-	Flue Baffle	11
	-	C540	Flue Baffle	16
A8	C235	C235	Andrews Label	1
A11	C487	C554	Top Cover	1
A12	C488	C488	Insulation Pad	1
A13	C490	E392	Flue Box Top Cover	1
A14	C299	C299	Cleanout Pad Seal	1
A15	C300	C300	Cleanout Pad	1
A16	C301	C301	Cleanout Pad Cove	1
A17	C247	C247	Drain Tapping Connector, 3/4 BSP	1
A19	C534	C534	Nipple, 1 1/2 " BSP	4
A20	E050	E050	Hydrojet Cold Inlet Connection (side) 1 1/2" BSP	1
B1	C567	C568	Burner Assy. comprising items B2 - B6 and B8 - B9	1
B2	C503	-	Burner Bar	7
B2	-	C503	Burner Bar	9
B3	C545	C550	Burner Manifold	1
B4	C572	-	Injector 1.78mm	7
	-	C572	Injector 1.78mm	9
B5	C576	C572	Pilot Assy. c/w injector and electrode	1
B6	C547	C576	Pilot Supply Pipe	1
B7	C316	C316	Pilot Injector	1
B8	C552	C552	Thermopile	1
B9	C575	C575	Multifunctional Valve	1
B10	C539	C539	Control Thermostat with remote phial and ECO	1
B12	C560	C560	Lead Assy. Thermostat to Gas Valve	1
B13	C136	C136	Pressure Test Nipple	1
B14	C514	C514	Piezo Igniter	1
B16	C499	C499	Gas Cock 3/4" BSP FxF	1
B17	C578	C578	Inlet Nipple 3/4" NPT/3/4" BSP	1
B19	E418	E418	Pilot Shield	1

**Unvented Systems
Kit - Standard
Range**

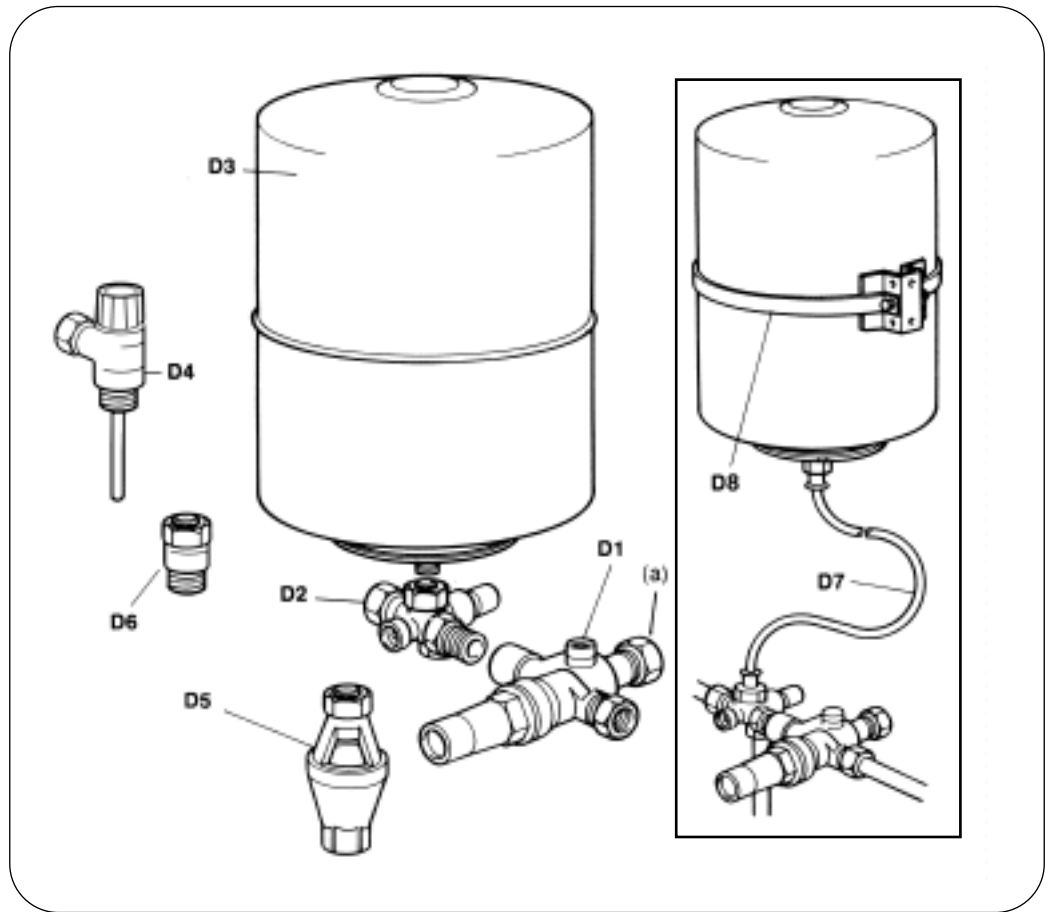

**Unvented Systems
Kit - Hi-Flo Range**

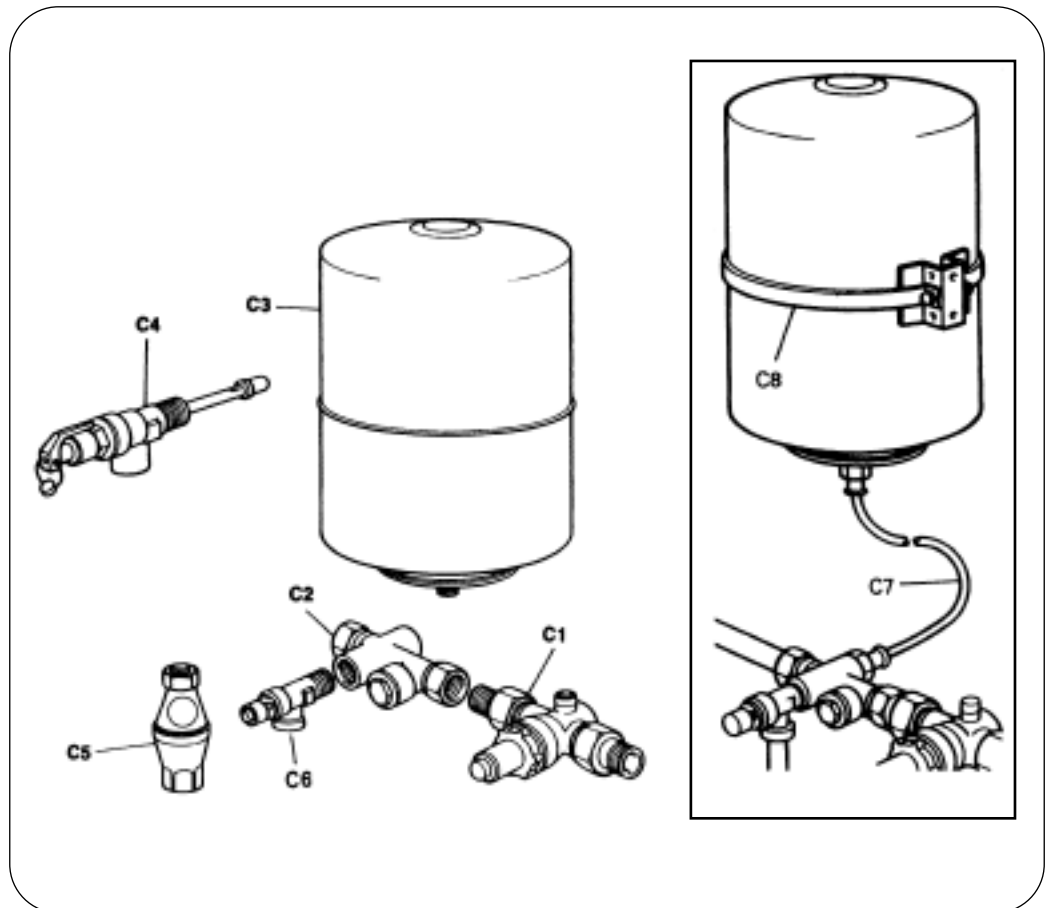

Ref.	Part No.	Description	Qty
	B171	Unvented Systems Kit Complete	1
D1	C780	Pressure Reducing Valve/Strainer	1
D2	C781	Check Valve / Expansion Vessel	1
D3	C782	Expansion Vessel	1
D4	C456	Temperature/Pressure Relief Valve	1
D5	C783	Tundish	1
D6	C772	Adaptor	1
	B173	Wall Mounting Kit for Expansion Vessel	
D7	C788	Hose Assembly	1
D8	C787	Wall Bracket Assembly	1

Unvented Systems Kit - Standard Range

Ref.	Part No.	Description	Qty
	B172	Unvented Systems Kit Complete	1
C1	C784	Pressure Reducing Valve/Strainer	1
C2	C785	Check Valve	1
C3	C782	Expansion Vessel	1
C4	C380	Temperature/Pressure Relief Valve	1
C5	C384	Tundish from Temperature/Pressure Valve	1
C6	C786	Expansion Valve	1
	B173	Wall Mounting Kit (Optional)	
C7	C788	Hose Assembly	1
C8	C787	Wall Bracket Assembly	1

Unvented Systems Kit - Hi-Flo Range

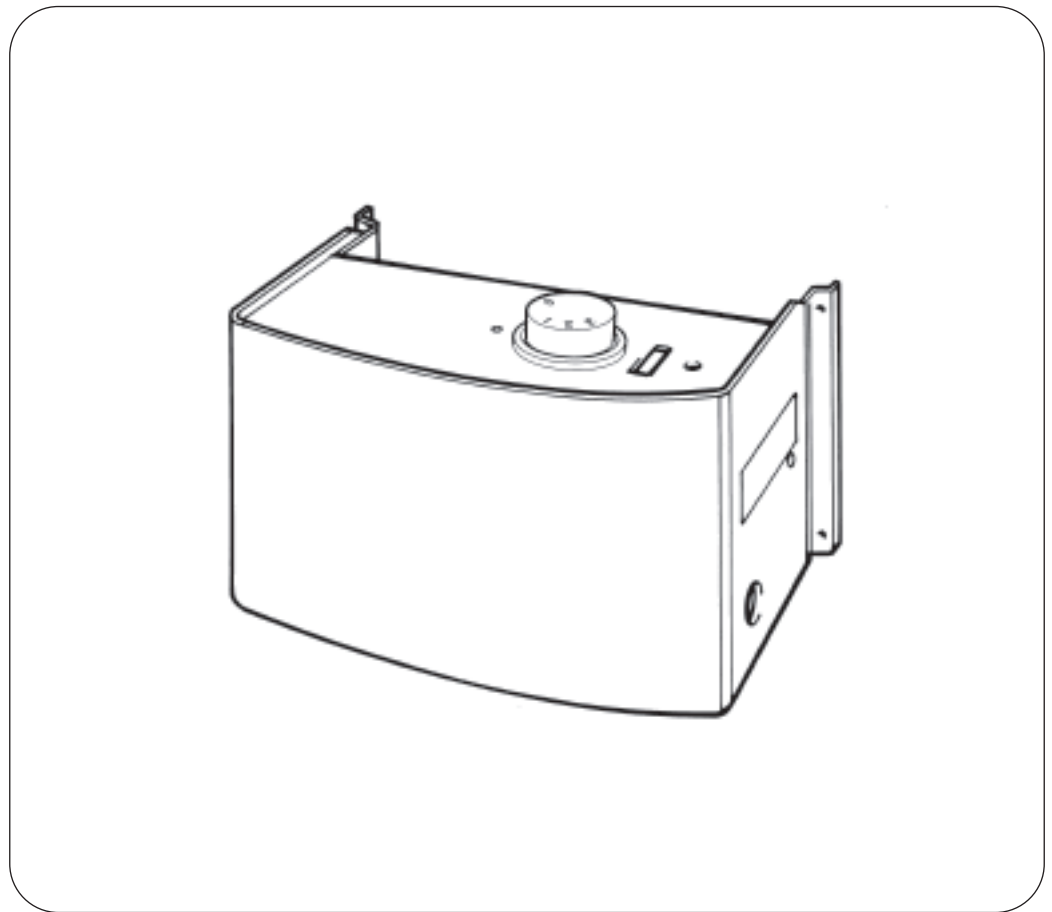
SECTION 9**PARTS LIST AND ILLUSTRATIONS****24 Volt Auto System
Kit B252
With Timer B253****24 Volt Auto
System Kit
Standard Range**

Part No.	Description	Qty
B217	240 Volt Auto System Kit Complete (nat gas)	1
C521	On/Off Switch	1
C641	Mains Indicator Light	1
G122	EP6 Control Module	1
E115	Transformer	1
E116	Limit Thermostat	1
E117	Control Thermostat	1
E120	Control Thermostat Knob	1
G059	230 volt Gas Valve	1
E126	230 volt Solenoid Coil	2
E127	Pilot Assembly (nat gas)	1
E128	Ignition/Flame Probe	1
E135	HT Lead 24"	1

PART OF BDR THERMEA

Baxi Commercial Division
Wood Lane, Erdington,
Birmingham B24 9QP
Email: andrews@baxigroup.com
www.andrewswaterheaters.co.uk

Sales:
0845 070 1056
Technical:
0845 070 1057

