

T/D 008

CORREX POWERED ANODES HI-FLO RANGE WATER HEATERS NAT GAS AND LPG

FITTING AND OPERATING INSTRUCTIONS FOR HI-FLO RANGE

THE INTRODUCTION OF THIS KIT HAS THREE MAIN ADVANTAGES TO BE CONSIDERED

- LOW MAINTENANCE COSTS (Correx is non-sacrificial, therefore no anode maintenance is needed).
- LOW RUNNING COSTS – LESS THAN 35kWH PER YEAR.
- BETTER PROTECTION PARTICULARLY IN AREAS OF LOW ELECTRICAL CONDUCTIVITY.

Wiring external to the water heater must be installed in accordance with the I.E.E. Regulations for the wiring of buildings and to any local regulations that may apply.

This kit is designed to run off 220/240V 1 ph 50 Hz permanent supply and the fuse rating is 3 Amp.

The method of connection to the mains electricity supply should facilitate complete electrical isolation of the appliance preferably by use of an unswitched shuttered socket outlet in conjunction with a fused three pin plug both complying with requirements of BS 1363/A.

Alternatively a fused double pole switch or fused spur box serving only the heater may be used.

The point of connection to the mains should be readily accessible and adjacent to the appliance.

A. To install the kit

- Drain down water heater.
- Remove cold inlet hydrojet nipple and replace with 1½ nipple supplied in fittings pack.
- Fit correx anodes into front hot and cold water connections using tees and bushes. If top water connections of heater are to be used (dependent on model type) cap off front connections with blanking caps (see Figs. 1 and 2). Note – leave existing magnesium anodes in position.
- Fix potentiostat to heater casing, using retaining bracket. (See Fig. 1)
- Connect output leads onto anode connections. Cut leads to required length and use two spade connectors provided. (See Fig. 1)
- Fit earth strap to 1½ BSP sq. tee optional hot outlet connection. Connect earth return at this point. Cut lead to required length and use spade terminal provided (see Fig. 1).
- Connect potentiostat mains input cable to a permanent 240V electrical supply via an unswitched spur outlet (fuse rating 3 Amps).

B. Test the installation

- Refill the water heater and check for leaks.
- Switch on electrical supply to correx powered anode.
- The green control lamp on the potentiostat indicates that the installation is functioning correctly.
- The red control lamp on the potentiostat indicates a fault. Switch off electrical supply before any repair work is carried out.

The installation is now complete.

FIG. 1

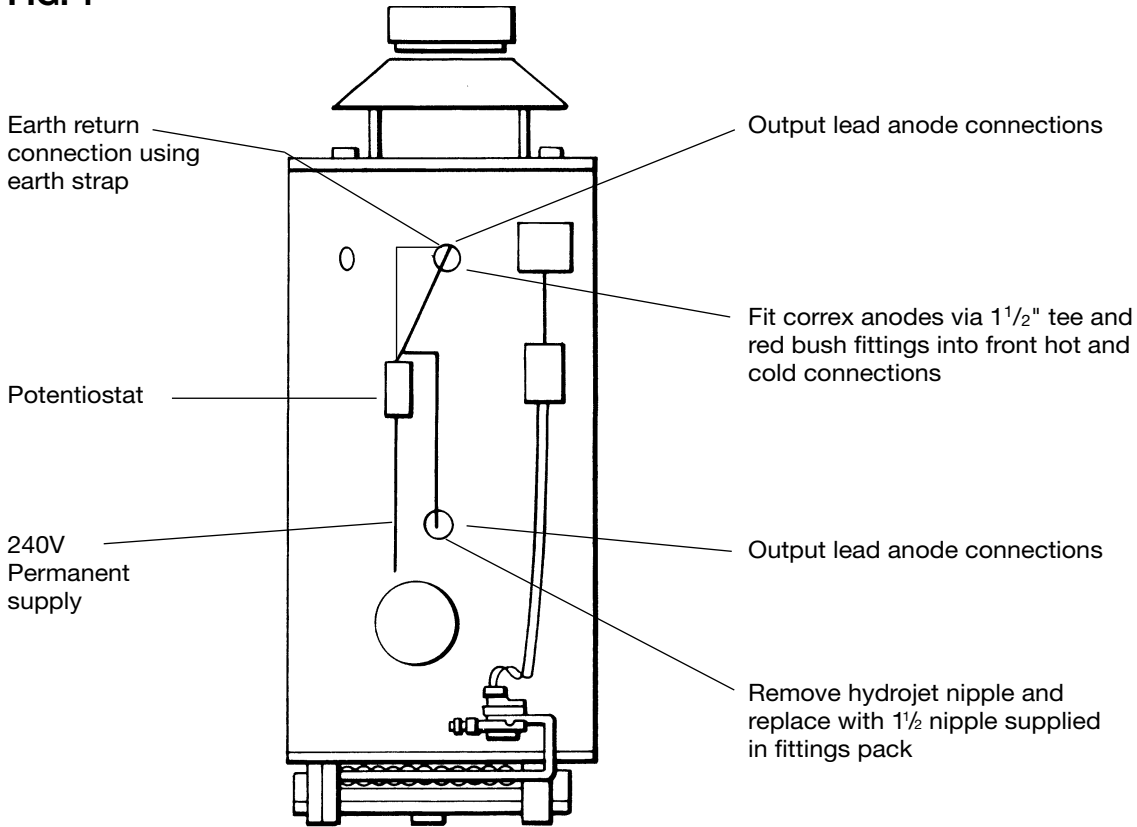

FIG. 2

HI-FLO RANGE WATER HEATERS NAT GAS AND LPG

MODEL	No. CORREX ANODES/SIZE
32/143	2 x 800mm
65/173	2 x 800mm
81/264	2 x 800mm
62/341	2 x 800mm
54/418	2 x 800mm
54/440	2 x 800mm
L32/143	2 x 800mm
L65/169	2 x 800mm
L81/251	2 x 800mm
L62/309	2 x 800mm
L54/399	2 x 800mm

Powered anode fittings pack – Part No. B184

- 2 – Correx powered anodes E048
- 1 – Potentiostat E010
- 2 – 1 1/2" BSP Sq. tees C856
- 2 – 1 1/2" x 3/4" BSP Red Bushes C857
- 1 – 1 1/2" Nipple C534
- 1 – Earth Strap E049
- 1 – Envelope containing spade and ring terminals fixing clamps/clips



Andrews Water Heaters
 Wood Lane, Erdington
 Birmingham B24 9QP
 Telephone: 0845 070 1058 Fax: 0845 070 1059
 E-mail: andrews@andrews-waterheaters.co.uk

Since it is our policy to strive for progressive design and performance all our equipment is subject to