

---

# ETS

## Electric boilers

### *Installation, Operating and Servicing Instructions*

#### **ETS 09 - 15**

Single phase

#### **ETS 09 - 15 - 24**

Tri phase



---

*excellence in hot water*

## CONTENTS

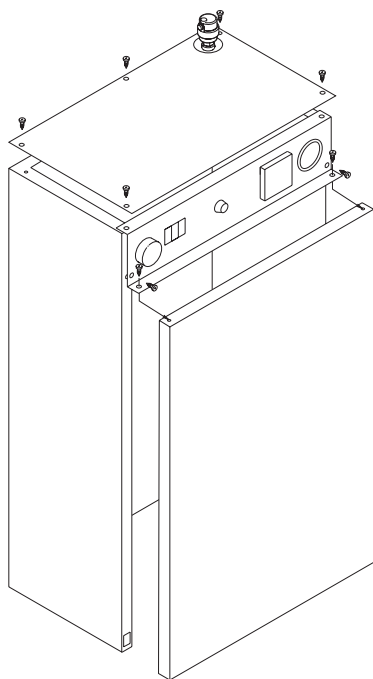

<b>INTRODUCTION</b>	2
<b>MANUAL HANDLING INFORMATION</b>	3
<b>USER INSTRUCTIONS</b>	4
<b>ELECTRICAL SPECIFICATION</b>	5
<b>PUMP CHARACTERISTICS</b>	6
<b>INSTALLATION</b>	7
<b>COMMISSIONING</b>	12
<b>COMPONENT REPLACEMENT</b>	13
<b>WIRING AND FAULT FINDING</b>	
ETS 09-15 Single phase : Control Circuit	18
ETS 09-15 Tri phase : Control Circuit	19
ETS 24 Tri Phase : Control Circuit	20
ETS 09-15 Single phase : Power Circuit	21
ETS 09-15 Tri phase : Power Circuit	22
ETS 24 Tri phase : Power Circuit	23
Honeywell Sundial Wiring Diagrams	24
ETS 09-15 Fault Finding	26
ETS 24 Fault Finding	27
<b>MAINTENANCE &amp; SERVICE LOG</b>	28

**Note :**

ACV reserves the right to modify the technical specifications and components of its products without prior notice.

## INTRODUCTION

### Introduction

The ETS is a wall hung electric system boiler with three models in the range :

- ETS 09 and 15 are available in either single phase or tri phase.
- ETS 24 is tri phase.

The boiler is equipped with all the necessary components to allow direct connection to a heating system without the need for a feed and expansion cistern. These components include; primary 8 litre expansion vessel (suitable for a system water content of up to 128 litres), pressure and temperature gauge, safety valve, circulating pump, low water pressure switch, control and high limit thermostats, on/off and power level switches.

The boiler heat exchanger is constructed from mild steel with welded joints and is insulated with a glass wool jacket and with aluminium cover. The steel casing has a white stove enamelled finish and a grey control panel.

Immersion heaters, constructed from stainless steel and mounted in the top of the boiler, provide the power source for the ETS Boiler. The ETS 09 and ETS 15 have 6 in total, and the ETS 24 has 10 (9 used with 1 spare).

The boiler is suitable for connection to most heating and hot water systems, with a maximum working pressure of 3bar and a maximum temperature of 85°C. The ETS can also be used in multiple boiler installations allowing greater outputs to be achieved.

Electrical connection access is located underneath the boiler, and connection glands for both the main power supply and optional external controls are provided, suitable for single or three phase electrical supply depending upon boiler output required. An internal 3 amp MCB is linked to the incoming electrical supply to provide the internal control circuit, from which optional controls can be connected e.g. internal or external timeclock, room thermostat or Honeywell Sundial controls.

The temperature of the boiler is controlled by a dual stage thermostat which is set by the user to give the desired boiler temperature. When the boiler has heated up to within 7°C of the set temperature, the thermostat switches off one power stage and therefore reduces the heat input.

Thanks to this simple but effective form of modulation, the ETS has longer working cycles and requires less stops and starts, thus resulting in a more even temperature across the boiler. It also means less wear and tear on components and, importantly it uses less power once it has reached working temperature.

The ETS Boilers have been manufactured to comply with the following standards BS EN60335-2-35:1998, BS EN55014-2:1997 and BS EN50081-1-1:1992.



## MANUAL HANDLING INFORMATION



The weight of this boiler is 36Kg, which could present a risk of injury.



We recommend that the boiler be handled by two people until it is securely fixed to a wall.



Care should be taken when loading and unloading the boiler to and from vehicles.



The safest route from the vehicle to the point of installation should be carefully assessed before unloading the boiler.



Mechanical lifting aids should be utilised whenever possible.

### REMOVING THE BOILER FROM THE PACKAGING

- Before lifting the boiler from the packaging, ensure that the installation area is clear and that there are no obstacles making installation difficult or unsafe.
- Lay the boiler on its back (as shown on the box side), open the box and remove the cardboard packaging.
- Remove the polythene cover and the polystyrene corner protection pieces.
- With the boiler still in the box, remove the boiler front cover panel screws "A" as described on page 7.
- Put the front cover panel safely aside to avoid damage.
- With the front cover panel removed, the two panel bottom retaining tabs on the casing can be seen - **these can be sharp** and care must be taken when lifting the boiler.
- With help from another person, lift the boiler from the packaging holding the lipped front edges of the side panels.
- Do not lift or carry the boiler using the top automatic air vent and bottom pump.

## USER INSTRUCTIONS

### User Data

All user controls are situated on the front panel of the boiler, there are no user controls inside the boiler casing. The following instructions assume that the boiler has been commissioned, and that the system is filled with water and has been fully vented.

### Setting Up

- Before switching on any electrical supplies to the boiler ensure that the combined temperature and pressure gauge reads at least 1 bar and the control thermostat is set to the desired temperature.
- If an internal time clock is fitted ensure that this is switched on (see "Optional Internal Time Clock") and if any other auxiliary controls are fitted e.g. programmer, room thermostats, cylinder thermostats etc, consult appropriate manufacturers' instructions to switch these on.
- Switch on any local means of isolation to boiler.
- Switch the boiler on using the ON/OFF switch (the red neon light on the switch should now glow).
- Turn on both power level switches - after a short period of time the boiler temperature should start to rise, indicated by the combined temperature and pressure gauge. If the boiler fails to operate, the overheat safety thermostat should be checked. Access to the thermostat reset button is obtained by unscrewing (anti-clockwise) the domed button cover on the front panel (a screwdriver is not required). The reset button can then be seen - press the button, a click should be heard and the button is reset. If no click was heard the device is not at fault and further investigation is required by a suitably qualified engineer.

- The internal clock or external programmer can now be set to allow on/off periods as desired. The ON/OFF switch and 2 power level switches should be left in the ON position during normal use.

NOTE : the power level switches will automatically switch on and off during normal boiler operation, depending on boiler temperature.

- If the boiler is not in regular daily use during cold periods, it is recommended that it be fitted with a frost sensing thermostat to override the timeclock and prevent the system from freezing.
- As with most boilers and heating appliances the casing and pipework can get hot during normal running so the boiler must not be covered and the surrounding area must be kept clear.

### Optional Internal Timeclock

- This operates on a 24-hour sequence. Around the outside of the clock there are a number of white tabs - these allow 15 minute switching times. To set a boiler cycle simply push outwards the number of tabs required for your heating period.

Remember : tab OUT = BOILER ON  
tab IN = BOILER OFF

The time of day is marked by an arrow on the inner part of the clock - set the outer time to coincide with this arrow.

On the centre part of the clock there is a switch. This has three positions :

- Switch down - timeclock off
- Switch middle - timeclock timed (normal position)
- Switch up - timeclock on constant.

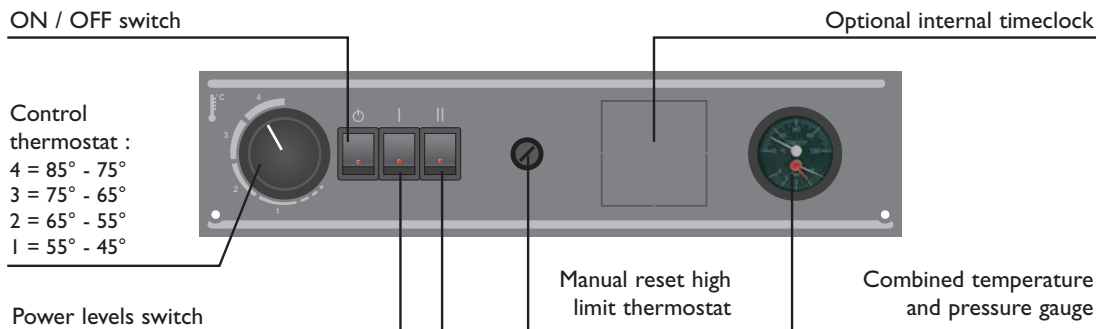

## ELECTRICAL SPECIFICATION

### Technical Data

MODEL	ETS 09 Single phase	ETS 09 Tri phase	ETS 15 Single phase	ETS 15 Tri phase	ETS 24 Tri phase
<b>Code</b>	00608708	00608808	00608908	00609008	00609108
<b>Gas Council N°</b>	EB 052 01	EB 052 01	EB 052 02	EB 052 02	EB 052 03
Nominal output (kw)	8.4	8.4	14.4	14.4	21.6
Height (mm)	720	720	720	720	720
Width (mm)	430	430	430	430	430
Depth (mm)	300	300	300	300	300
Weight empty (kg)	36	36	36	36	36
Weight full (kg)	49	49	49	49	49
No of elements	6	6	6	6	10 (*)
Element	1400 Watts	1400 Watts	2400 Watts	2400 Watts	2400 Watts
Water capacity (L)	13	13	13	13	13
Primary expansion vessel capacity (L)	8	8	8	8	8
Primary connections BSP	3/4"	3/4"	3/4"	3/4"	3/4"
Max working pressure (bar)	3	3	3	3	3
Primary pressure drop (mbar)	1	1	2	2	5
Max temperature (°C)	85	85	85	85	85
Nominal supply voltage (V)	230	3 x 400 + N	230	3 x 400 + N	3 x 400 + N
Nominal supply amps (total)	36	36	63	63	94
Nominal supply amps (per phase)	36	12	63	21	31
Protection against electric shock	Class I	Class I	Class I	Class I	Class I
IP rating	IPX I	IPX I	IPX I	IPX I	IPX I

(\*) Only 9 used 1 spare.

### ELECTRICAL SPECIFICATION

BOILER TYPE	ETS 09 Single phase	ETS 09 Tri phase	ETS 15 Single phase	ETS 15 Tri phase	ETS 24 Tri phase
<b>Code</b>	00608708	00608808	00608908	00609008	00609108
<b>Gas Council N°</b>	EB 052 01	EB 052 01	EB 052 02	EB 052 02	EB 052 03
<b>kW RATING (based upon 230 volts)</b>					
STAGE 1 POWER RELAY 1 (kW)	2.8	4.2	4.8	7.2	7.2
STAGE 1 POWER RELAY 2 (kW)	2.8	-	4.8	-	7.2
STAGE 2 POWER RELAY 1 (kW)	2.8	4.2	4.8	7.2	7.2
TOTAL kW <i>See table below</i>	8.4	8.4	14.4	14.4	21.6
NOMINAL VOLTAGE	230 V / 50 Hz	400 V / 50 Hz	230 V / 50 Hz	400 V / 50 Hz	400 V / 50 Hz

### Power variation (kW) relative to voltage

BOILER TYPE	ETS 09 Single phase	ETS 09 Tri phase	ETS 15 Single phase	ETS 15 Tri phase	ETS 24 Tri phase
220 V	7.6	-	13.1	-	-
230 V	8.4	-	14.4	-	-
240 V	9.0	-	15.6	-	-
3 x 380 V	-	7.6	-	13.1	19.5
3 x 400 V	-	8.4	-	14.4	21.6
3 x 415 V	-	9.0	-	15.6	23.3

The electrical installation of this boiler including cable sizes and protection devices and switches must comply with the current IEE Regulations.

## PUMP CHARACTERISTICS

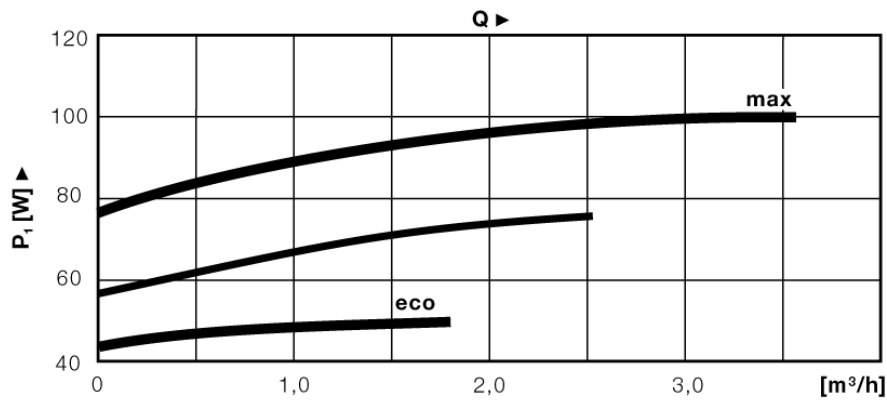
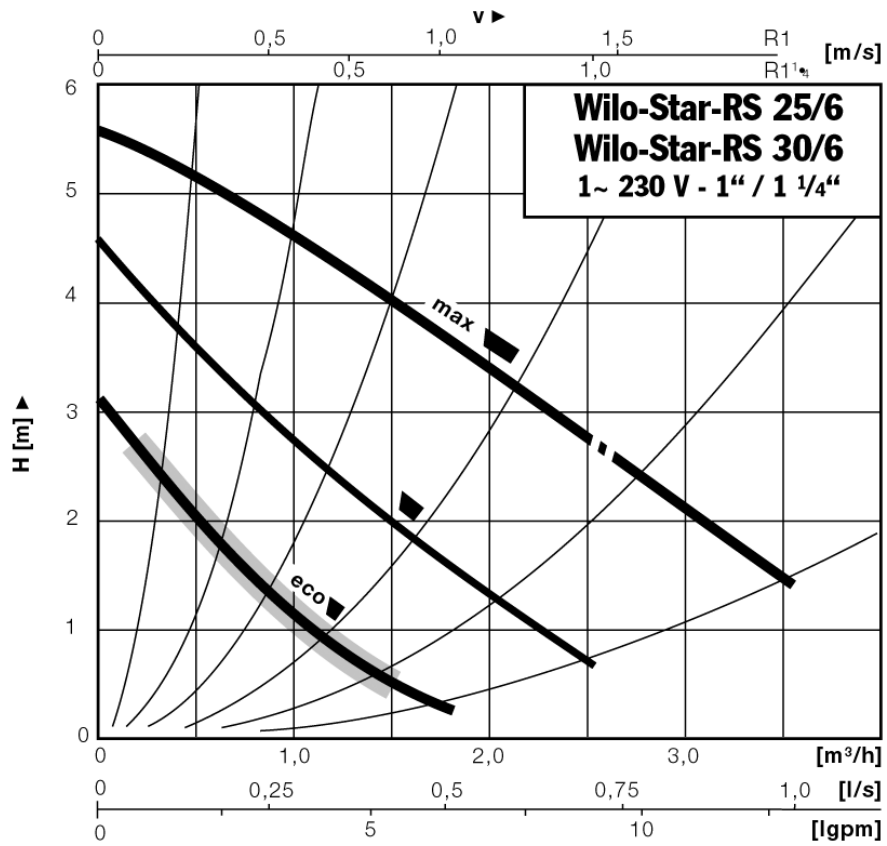

## WILO-STAR-RS 25/6 - 130 MM

### DESCRIPTION

- Screwed end single head pump
- Manual 3-speed control
- Non-overloading single phase motor

## INSTALLATION

### Dimensions

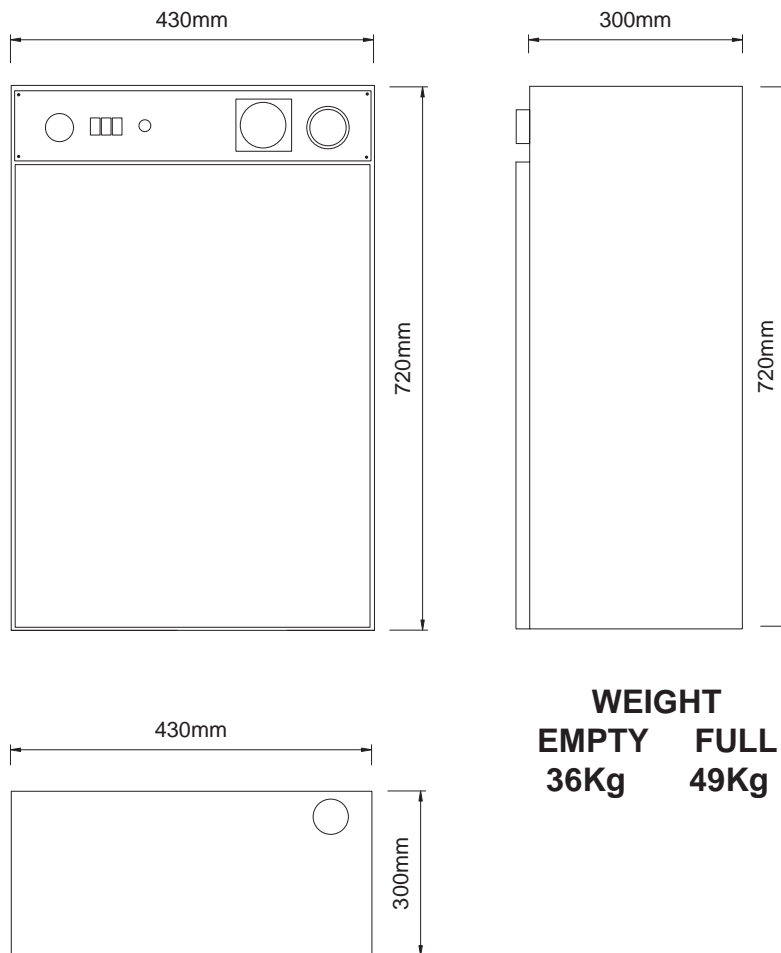

WEIGHT	
EMPTY	FULL
36Kg	49Kg

### Connecting to the System

The ETS boiler is designed to operate on a sealed system (ie. no open vent or feed and expansion cistern). Hot water expansion within the system is taken up by the internal 8 litre expansion vessel. This is suitable for systems up to 128 litres capacity. If the system capacity is more than this then an additional expansion vessel may be required. This can be fitted external to the boiler at a convenient place on the pipework.

Please note that the circulation pump is fitted to the flow connection.

### Safety Valve Connection

The boiler safety valve (set at 3 bar) must be piped to drain using metallic pipe (eg. copper) minimum size 15mm.

### Frost Protection

The boiler is **NOT** fitted with frost protection. If the boiler is being installed in a position where freezing could take place, then a suitable external frost thermostat should be fitted.



## INSTALLATION

### Mounting Boiler

- The boiler must be fixed to a non flammable wall.
- Observing the clearances shown below, drill 2 off 14mm x 100mm holes.
- Fit the 2 bolts supplied and hang the wall bracket.
- Fit washers and nuts
- Hang the boiler (see instructions on next page)

### Clearances and Fixings

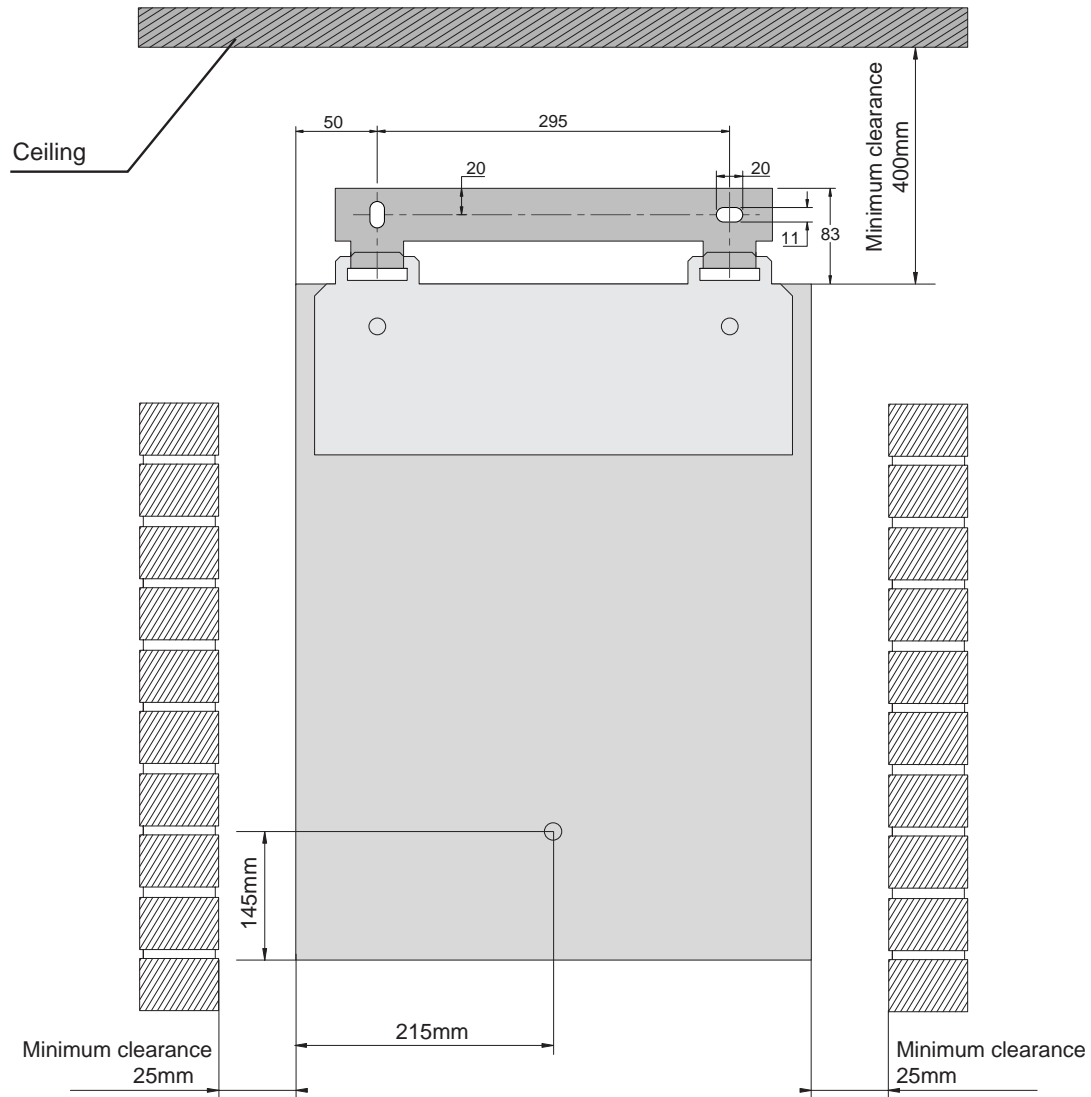

## INSTALLATION

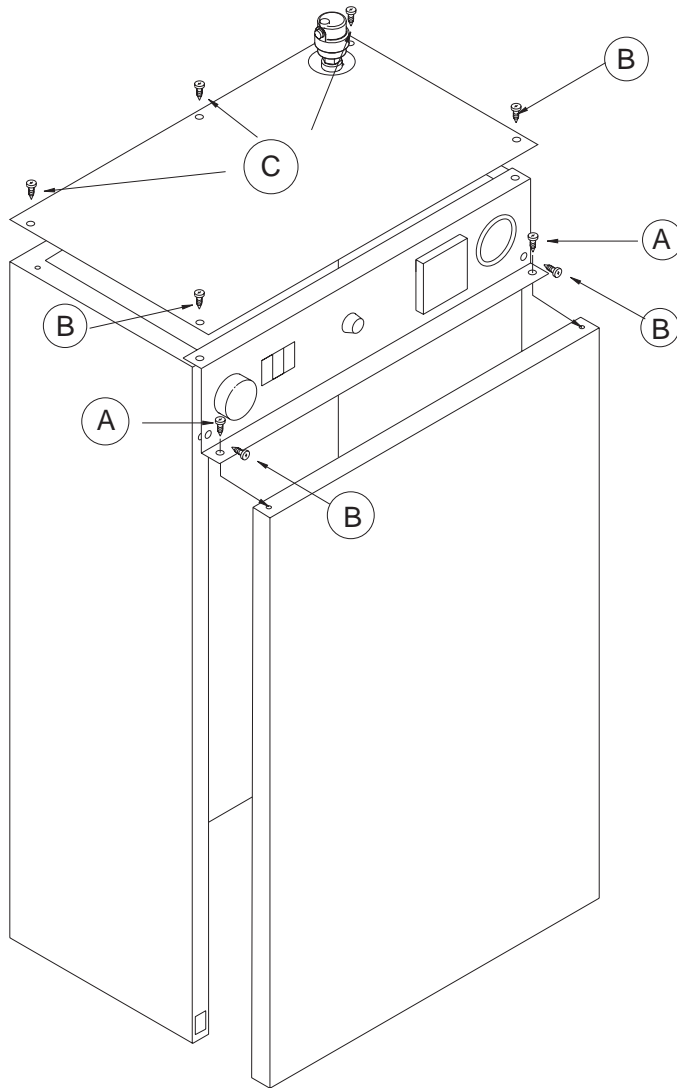

### Panel Removal

To mount the boiler, first remove the front cover panel :

- undo screws marked (A)
- tilt panel towards you and lift clear.

Then hang the boiler by positioning the hooks on the boiler over the wall bracket. Take care to ensure that the automatic air vent does not touch the bracket bolts.

The final fixing point can be found behind the pump - drill an appropriate hole and fit the bolt supplied together with the washer and nut.

For future maintenance only (not required when fitting the boiler) :

- To remove the control panel, undo screws marked (B) and draw panel towards you taking care not to pull off any connections to the rear of the panel.
- To remove the top cover, unscrew the automatic air vent then undo screws marked (C).

# INSTALLATION

## Pipework & System Connection

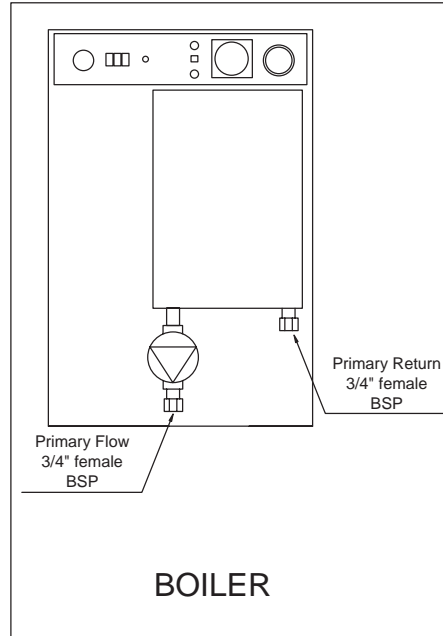
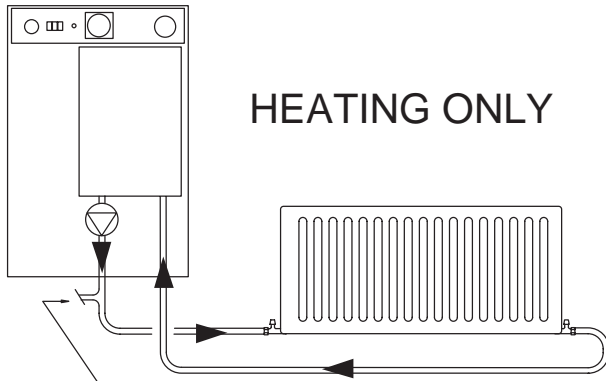

Suitable connection point for mains filling device Minimum size 15mm

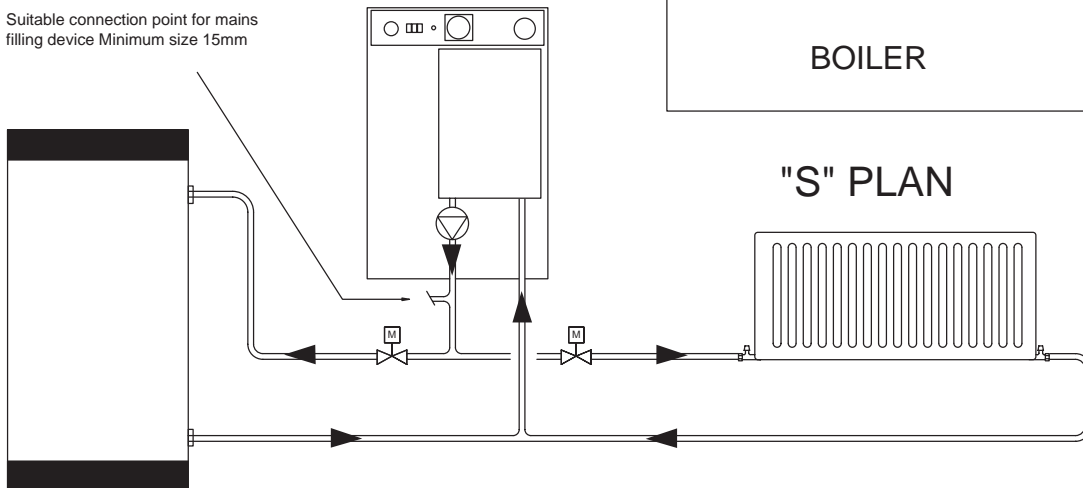

Suitable connection point for mains filling device Minimum size 15mm

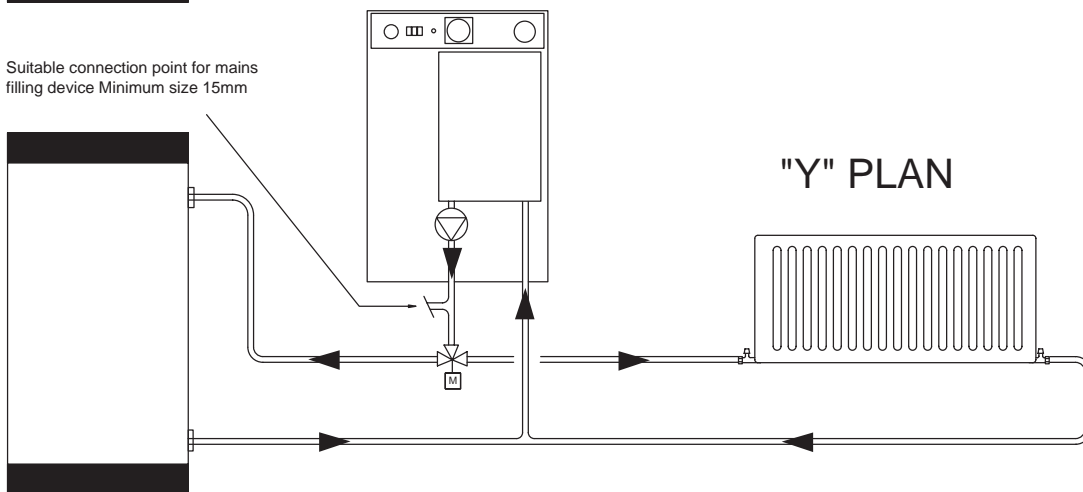

# INSTALLATION

## Electrical Connections

### 230V - 240V SP+N Installation

This appliance must be permanently connected to fixed wiring and must be earthed. The wiring must be carried out by a competent person and be in accordance with the current IEE Wiring Regulations. 2 Pole isolation must be provided with a minimum contact clearance of 3mm. The 2 Pole MCB must be readily accessible and adjacent to the appliance.

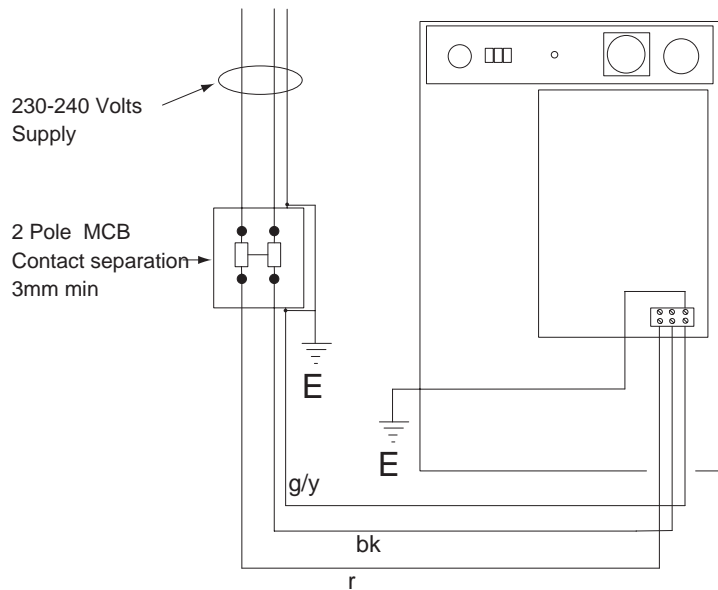

## Electrical Connections

### 400V TP+N Installation

This appliance must be permanently connected to fixed wiring and must be earthed. The wiring must be carried out by a competent person and be in accordance with the current IEE Wiring Regulations. 4 Pole isolation must be provided with a minimum contact clearance of 3mm. The 4 Pole MCB must be readily accessible and adjacent to the appliance.

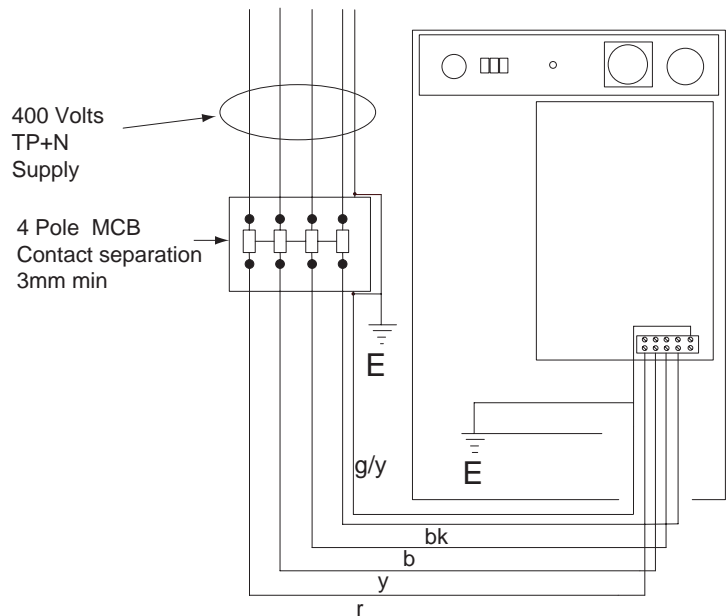

## COMMISSIONING

### Commissioning - Water

1. The system must be thoroughly cleansed prior to connection of the boiler. The system water should be treated to prevent general corrosion and deposition of scale or sludge in the boiler; please refer to BS7593. If installing the boiler onto an existing system, ACV recommend that an approved system cleaner is used.

2. Fill and pressurise the boiler and system to 1.5 bar, making sure to vent the boiler via the automatic air vent on top of the boiler. Note that the black dust cap on the air vent should be left loose to allow the auto vent to function.

3. Check for leaks.

For specialist advice on water treatment products, contact:

Fernox, Britannia Works  
Clavering, Essex CB11 4QZ  
Tel 01799 550811

### Commissioning - Electrical

The Electrical installation supplying this boiler must conform to the current IEE Regulations.

1. Remove the front panel and check all electrical connections for tightness.
2. Ensure all internal relays, contactors etc are secure on the DIN rails.
3. Set all panel control switches to off.
4. Check the power stage delay timer settings - Adjuster (A) is factory set to the 1 to 10 minute position which is the optimum setting for the boiler and should be verified during commissioning.

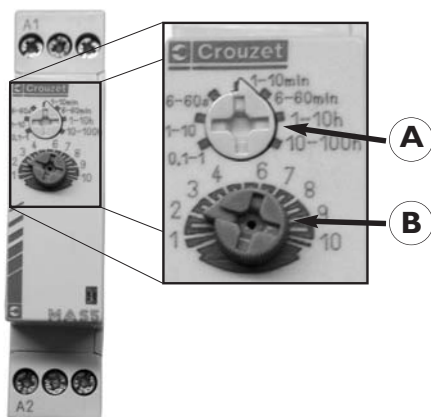

- Adjuster (B) is used to set the DELAY ON time of the following stage contactors, the available settings are in 1 minute increments if A is set to 1 to 10 minutes.

This function is particularly useful in areas where gradual switching of electrical load is required and the resulting maximum demand kept to a minimum. The timers add to the flexibility of the installation but must be optimised by a qualified engineer. The normal setting is 1.

5. Set internal MCB to off position.

6. Set the control thermostat to desired temperature.

### Starting the Boiler

1. Switch on the internal or external timeclock (if fitted)
2. Switch on internal MCB
3. Switch on local isolator to boiler
4. Turn the boiler on using the ON/OFF switch
5. Switch on the power levels switch stage 1, the first stage contactors will energise
6. Switch on the power levels switch stage 2, after a short delay the second stage contactors will energise. Note: the power stage delay timer settings should be verified as shown in item 4 under "Commissioning - Electrical"
7. The boiler temperature will now rise as indicated by the combined temperature and pressure gauge
8. The temperature will continue to rise until the control thermostat temperature setting is reached then the boiler will switch off.

Once these procedures have been followed the system can be left to operate normally by the following method.

1. Ensure that boiler thermostat is set to the desired temperature
2. Turn the boiler on using the ON/OFF switch
3. Turn on power level switch 1
4. Turn on power level switch 2
5. Set timeclock (if fitted) and/or external controls to desired boiler operating on/off times.

After one week of operation all electrical connections should be re-checked for tightness and the boiler water system checked for leaks and air and rectified if necessary.

## COMPONENT REMOVAL AND REPLACEMENT

### Parts Location and Numbers

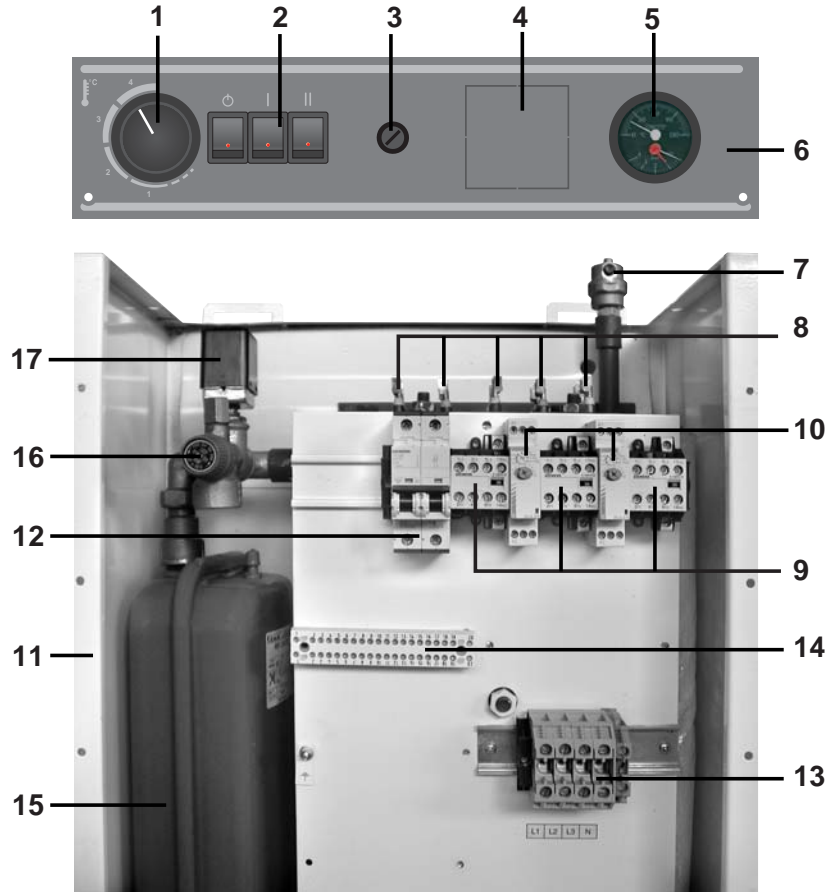

No.	Description	ACV Part	Gas council number
1	Control thermostat	54764014	E74- 998
2	Panel control switches	54428116	E75-007
3	Manual reset high limit thermostat	54764009	E75-000
4	Optional timeclock	54452000	E75-011
5	Combined temperature and pressure gauge	54441008	E74-998
6	Control panel (no parts)	21477053	E75-015
7	Automatic air vent	55445007	E75-014
8a	Element ETS 9	54428183	E75-012
8b	Element ETS 15/24	54428182	E75-013
9	20A Contactors	54452082	E75-005
10	Stage delay on timers	54428189	E75-006

No.	Description	ACV Part	Gas council number
11	Main boiler casing	21474065	E75-016
12	Control circuit MCB	54766015	E75-001
13	60A Terminals	54428179	E75-004
14	20 Way connector	54428199	E75-003
15	Expansion vessel	55301200	E75-010
16	Pressure safety valve	55426017	E75-008
17	Water pressure switch	557D3011	E75-009
-	Boiler casing lid	21475052	E75-017
-	Boiler casing front	21473052	E75-018
-	Circulating pump	557A4009	E75-002

# COMPONENT REMOVAL AND REPLACEMENT

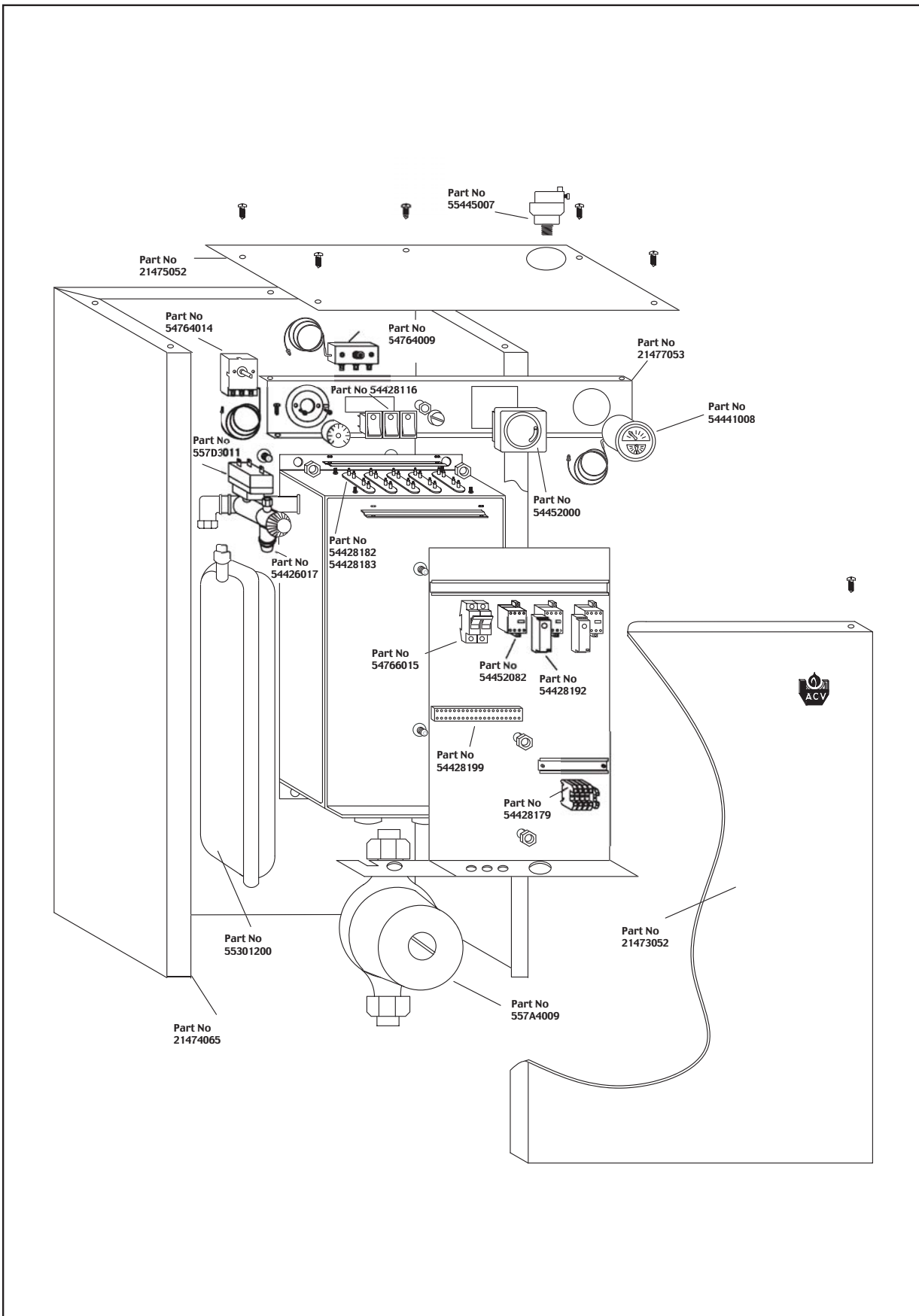

## COMPONENT REMOVAL AND REPLACEMENT

### Component Removal (Not requiring boiler draining)

#### Control Thermostat

ACV Part No 54764014

GC Part No E74-998

1. Isolate all electrical supplies to the boiler and remove the front panel fixing screws (2 off), then remove the control panel screws (4 off) and let panel hang forward.
2. Pull thermostat knob off the shaft and remove Phillips screws (2 off) holding bezel to panel. Disconnect the push-on electrical connectors from the thermostat body and remove from rear of panel.
3. Remove the capillary tube retaining clip from the control thermostat pocket next to elements, carefully remove the thermostat bulb.
4. Reverse the procedures to replace components.

#### Manual Reset High Limit Thermostat

ACV Part No 54764009

GC Part No E75-000

1. Isolate all electrical supplies to the boiler and remove the front panel fixing screws (2 off), then remove the control panel screws (4 off) and let panel hang forward.
2. Turn the black slotted domed cover on the control panel anti-clockwise and remove the lock nut holding the thermostat to the panel. Disconnect the push-on electrical connectors from the thermostat and remove the thermostat from the rear of the panel.
3. Remove the capillary tube retaining clip from the high limit thermostat pocket next to elements, carefully remove the thermostat bulb.
4. Reverse the procedures to replace components.

#### Combined Temperature and Pressure Gauge

ACV Part No 21477053

GC Part No E74-999

1. Isolate all electrical supplies to the boiler and remove the front panel fixing screws (2 off), then remove the control panel screws (4 off) and let panel hang forward.

2. Remove the capillary tube retaining clip from the thermostat pocket next to elements, carefully remove the thermostat bulb.
3. Undo the 14mm pressure gauge capillary nut on the pressure safety valve. Take care not to remove the miniature ball check valve. A small droplet of water may appear, this is normal.
4. Remove the gauge from the front of the control panel.
5. Reverse the procedures to replace components.

#### Timeclock

ACV Part No 54452000

GC Part No E75-011

1. Isolate all electrical supplies to the boiler and remove the front panel fixing screws (2 off), then remove the control panel screws (4 off) and let panel hang forward.
2. Disconnect the push-on electrical connectors from the timeclock.
3. On the front of the timeclock turn the 2 plastic slot screws anti-clockwise and pull the clock from the front of the panel.
4. Reverse the procedures to replace components.

#### Panel Control Switches

ACV Part No 54428116

GC Part No E75-007

1. Isolate all electrical supplies to the boiler and remove the front panel fixing screws (2 off), then remove the control panel screws (4 off) and let panel hang forward.
2. Disconnect the push-on electrical connectors from the rear of the switch. The switches are push fit through the front of the panel so must be pushed out from the back of the panel.
3. Reverse the procedures to replace components.



## COMPONENT REMOVAL AND REPLACEMENT

### Component Removal (requiring boiler draining)

#### Expansion Vessel

ACV Part No 55301200

GC No E75-010

1. Isolate all electrical supplies to the boiler.
2. Drain the heating system, (if isolating valves are fitted immediately below the boiler, then only the boiler requires draining).
3. Remove the vessel retaining bracket screws (2 off).
4. Undo the union on the top of the vessel and remove vessel from the boiler casing.
5. Reverse the procedures to replace the components.

#### Water Pressure Switch

ACV Part No 557D3011

GC No E75-009

1. Isolate all electrical supplies to the boiler.
2. Drain the heating system, (if isolating valves are fitted immediately below the boiler, then only the boiler requires draining).
3. Undo the 14mm pressure gauge capillary retaining nut and coupling from the pressure safety valve and pull aside the capillary tube.
4. Using a slim 14mm spanner on the brass part of the switch, remove the switch from the tee fitting - do not use any tools on the main switch body.
5. Using a suitable jointing compound, reverse the procedures to replace the components taking care to ensure that the jointing compound does not enter the pressure switch.

#### Pressure Safety Valve

ACV Part No 55426017

GC No E75-008

1. Isolate all electrical supplies to the boiler.
2. Drain the heating system, (if isolating valves are fitted immediately below the boiler, then only the boiler requires draining).
3. Undo the 14mm pressure gauge capillary retaining nut and pull the tube aside.

4. Remove the discharge pipe from the valve body.
5. Remove the two 17mm nuts holding the electrical component mounting plate, and move the plate to the right just enough to enable the anti-clockwise removal of the pressure safety valve.
6. Using a suitable jointing compound, reverse the procedures to replace the components taking care to ensure that the jointing compound does not enter the safety valve.

#### Automatic Air Vent

ACV Part No 55445007

GC No E75-014

1. Isolate all electrical supplies to the boiler.
2. Drain the heating system, (if isolating valves are fitted immediately below the boiler, then only the boiler requires draining).
3. Using a 17mm spanner remove the automatic vent and check valve.
4. Using a suitable jointing compound, reverse the procedures to replace the components taking care to ensure that the jointing compound does not enter the automatic air vent.
5. Remember to leave the black dust cap on the automatic air vent loose to allow correct operation of the vent.

#### Circulating Pump

ACV Part No 557A4009

GC No E75-002

1. Isolate all electrical supplies to the boiler.
2. Drain the heating system, (if isolating valves are fitted immediately below the boiler, then only the boiler requires draining).
3. Undo the pump unions above and below the pump, remove the pump.
4. Reverse the procedures to replace the components ensuring that the pump union gaskets are fitted to each end of the pump.

## COMPONENT REMOVAL AND REPLACEMENT

### Heating Elements

#### ETS 09

ACV Part No 54428183

GC No E75-012

#### ETS 15 and ETS 24

ACV Part No 54428182

GC No E75-013

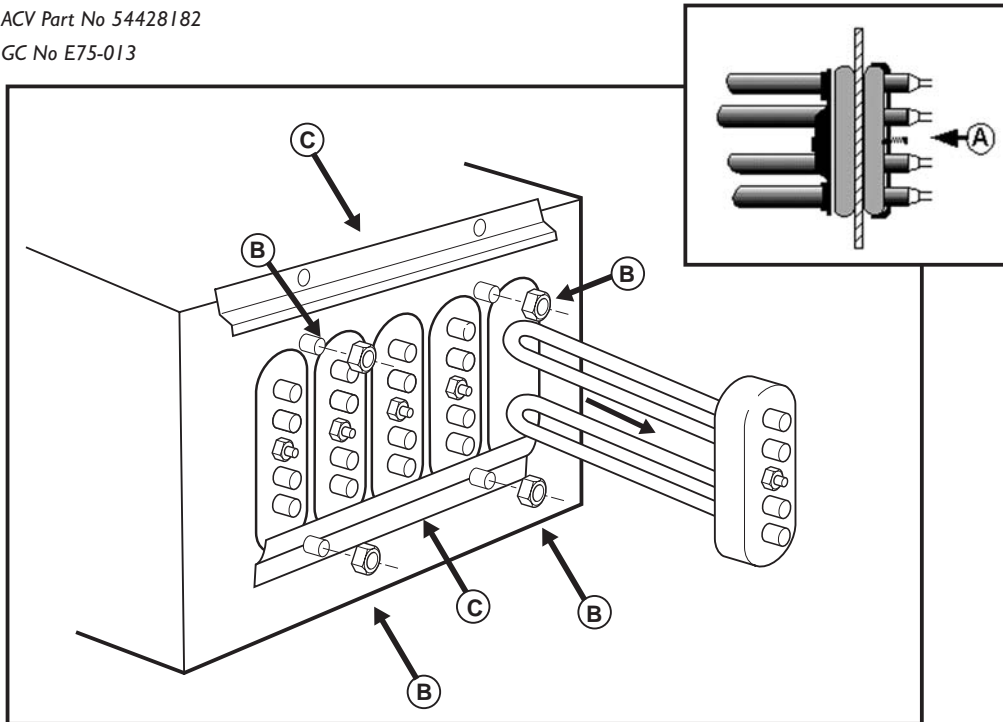

#### Procedure For Element Removal

1. Switch off all electrical supplies to the boiler and remove the panels.
2. Drain the boiler.
3. Disconnect the push-on electrical connectors from the elements taking note of the connecting order.
4. Use a 17mm socket to undo the four nuts from the element retaining plates (C) and remove the plates.
5. Use a socket to slacken the 10mm nut (A) and remove. Push the 10mm bolt into the boiler body (note: the bolt is captive and will not fall into the boiler body). This will de-compress the element gasket enabling the element to be withdrawn from the boiler.
6. Insert new element/s.
7. Refit the two element retaining plates (C) and nuts (B), tighten nuts (B). Then tighten the 10mm nut

on the element until the gasket is compressed and the element is tight in the boiler body.

8. Reconnect the push-on electrical connectors. Important - ensure that the connections are tight.
9. Refill the system and pressurise to 1 bar ensuring that ALL the air is removed from the system and boiler.
10. Reinststate the electrical supply and set the boiler thermostat to 40°C.
11. Run the boiler for approx 30min at this temperature checking for leaks around the element gaskets.
12. Check again for air in the system and the boiler, and vent if necessary. Set the timeclock and boiler thermostat appropriately.
13. Remember to leave the black dust cap on the automatic air vent loose to allow correct operation of the vent.

# WIRING DIAGRAMS - ETS 09-15 Single phase : Control Circuit

## ETS 09-15 Single phase : Control Circuit

Cable colour codes	
b	- blue
bk	- black
br	- brown
r	- red
w	- white
y	- yellow
o	- orange
v	- violet
p	- pink
gr	- grey

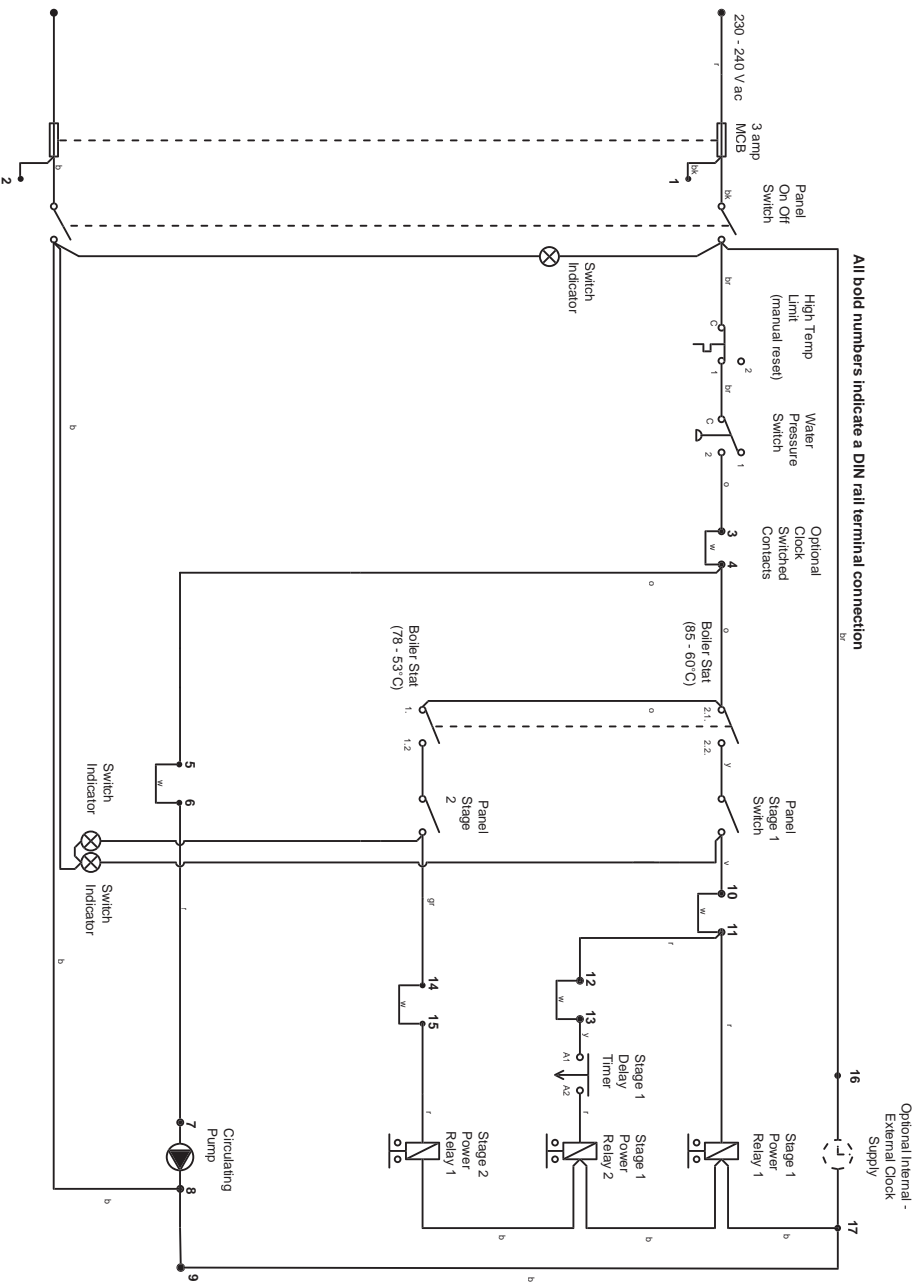

**PLEASE NOTE:** Due to the potential risk of **ELECTRIC SHOCK** this section of the manual is intended for use by a service engineer or qualified electrician, not the user.

# Tri phase : Control Circuit ETS 09-I5

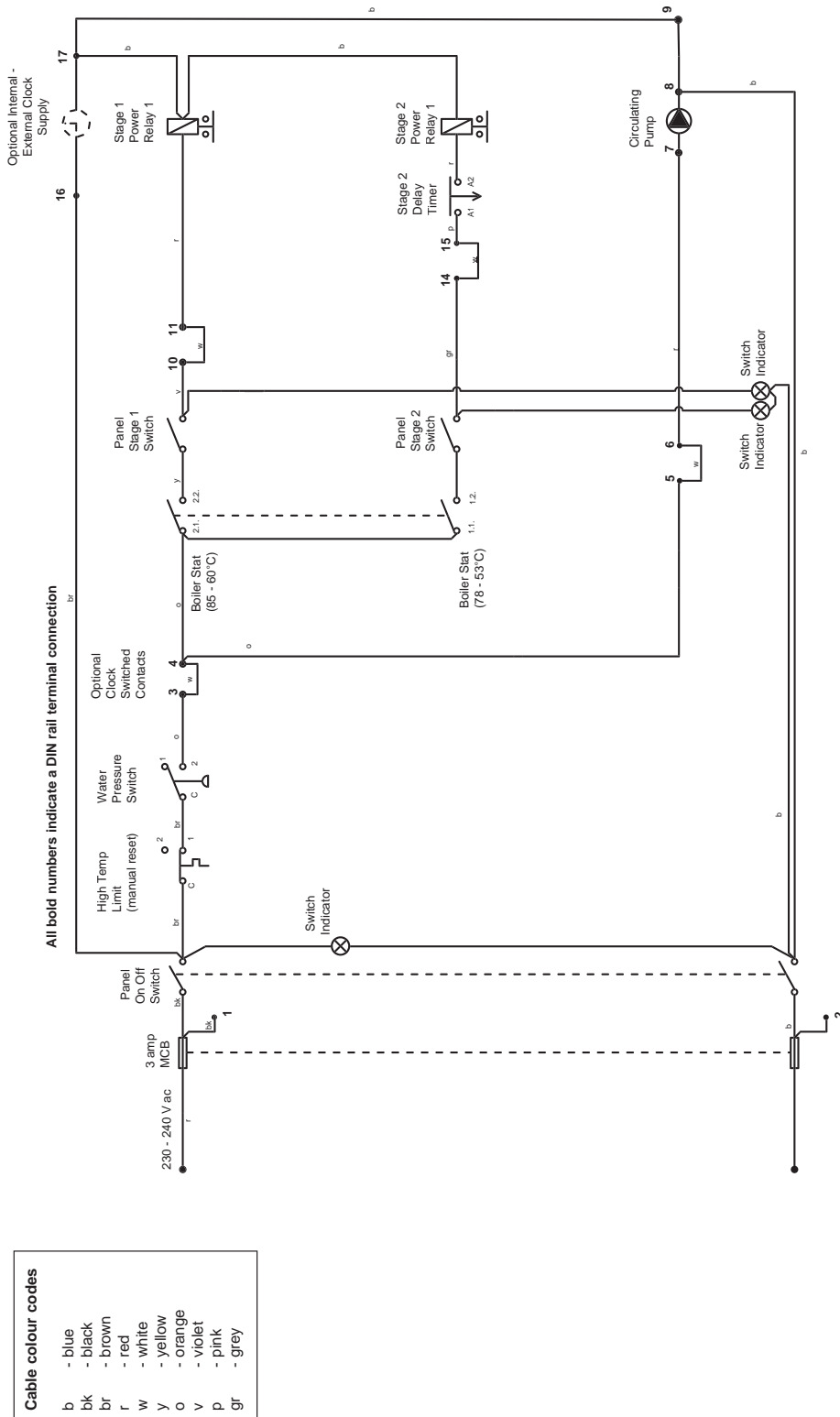

**PLEASE NOTE:** Due to the potential risk of ELECTRIC SHOCK this section of the manual is intended for use by a service engineer or qualified electrician, not the user.

# WIRING DIAGRAMS - ETS 24 Tri phase : Control circuit

## ETS 24 Tri phase: Control Circuit

Cable colour codes	
b	- blue
bk	- black
br	- brown
r	- red
w	- white
y	- yellow
o	- orange
v	- violet
P	- pink
gr	- grey

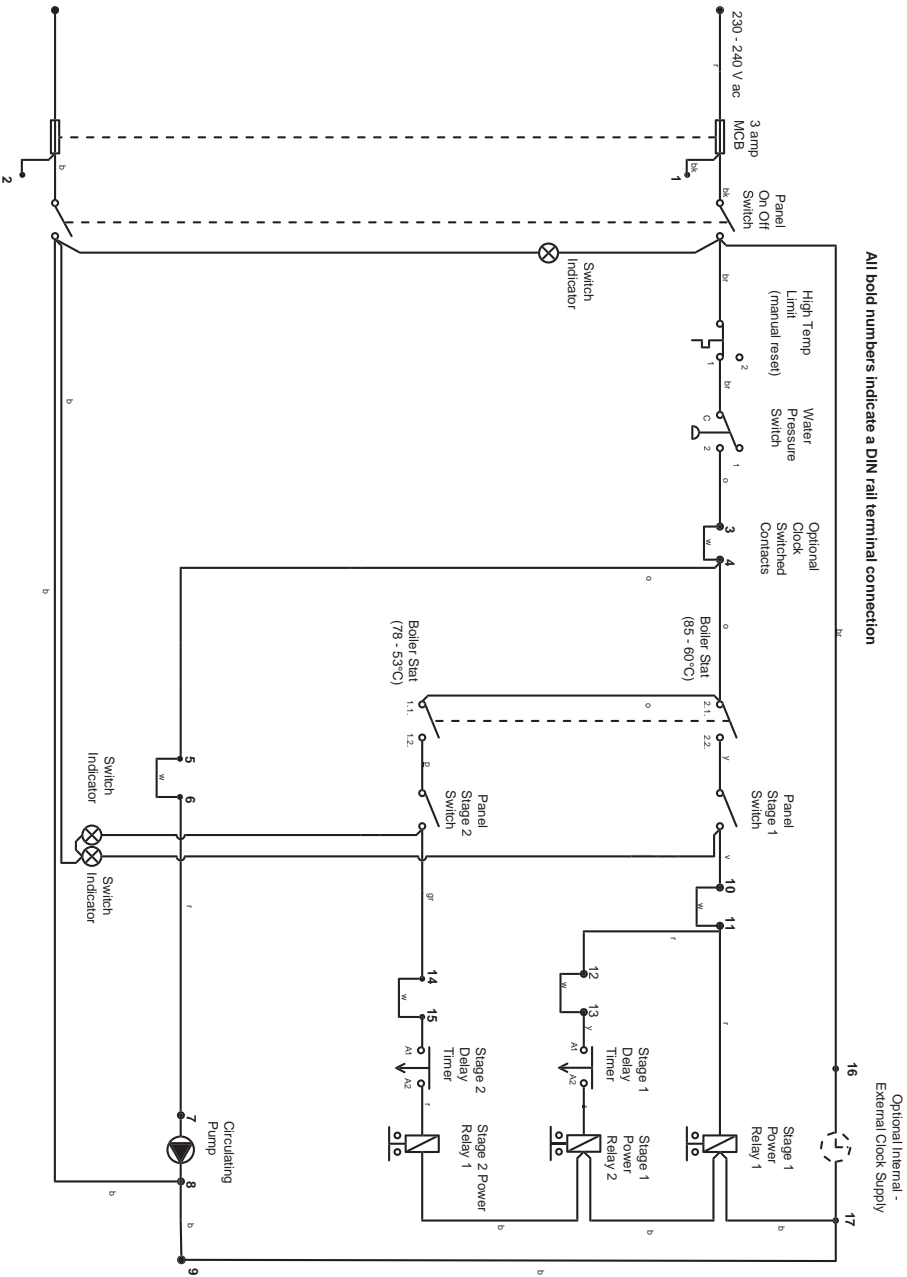

**PLEASE NOTE:** Due to the potential risk of **ELECTRIC SHOCK** this section of the manual is intended for use by a service engineer or qualified electrician, not the user.

# ETS 09-15 Single phase : Power Circuit

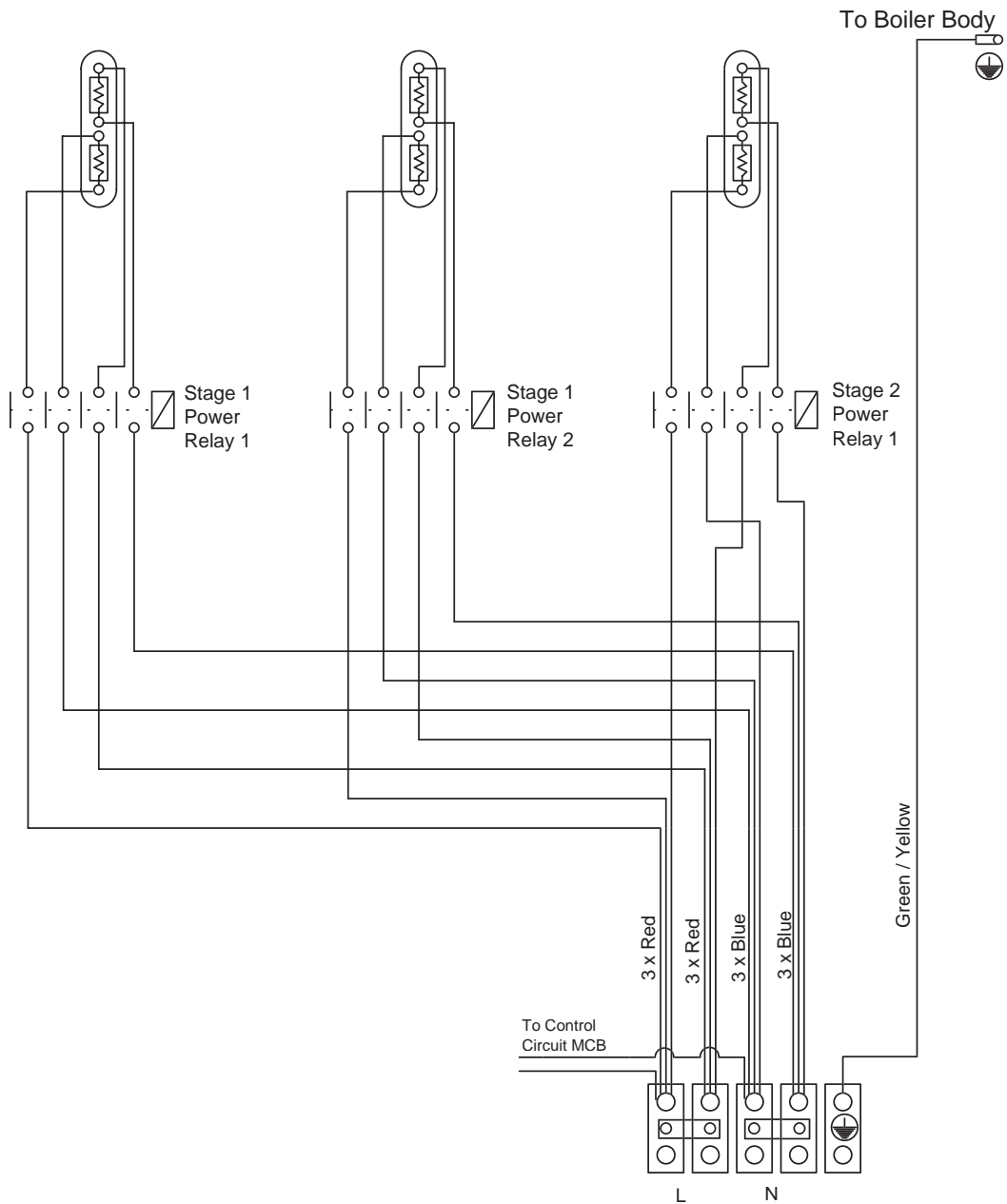

**PLEASE NOTE:** Due to the potential risk of ELECTRIC SHOCK this section of the manual is intended for use by a service engineer or qualified electrician, not the user.

# ETS 09-15 Tri phase : Power Circuit

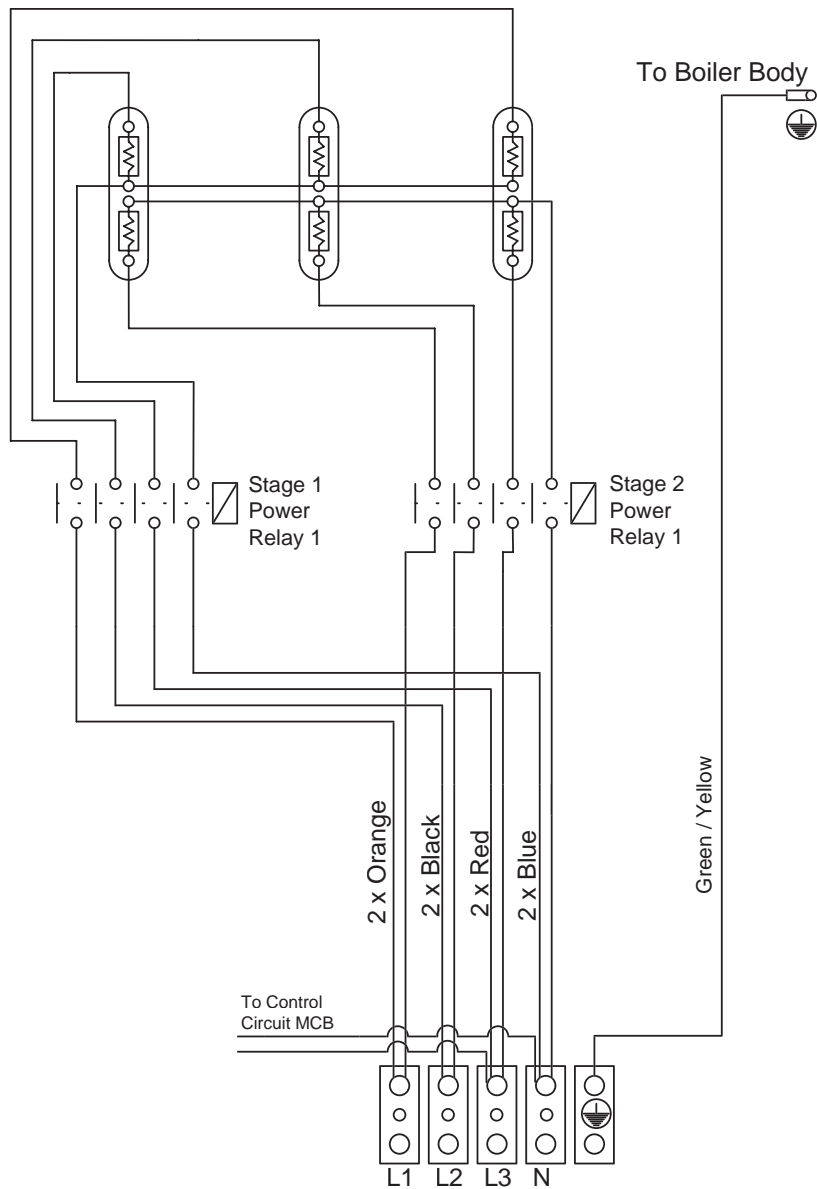

**PLEASE NOTE:** Due to the potential risk of ELECTRIC SHOCK this section of the manual is intended for use by a service engineer or qualified electrician, not the user.

# ETS 24 Tri phase : Power Circuit

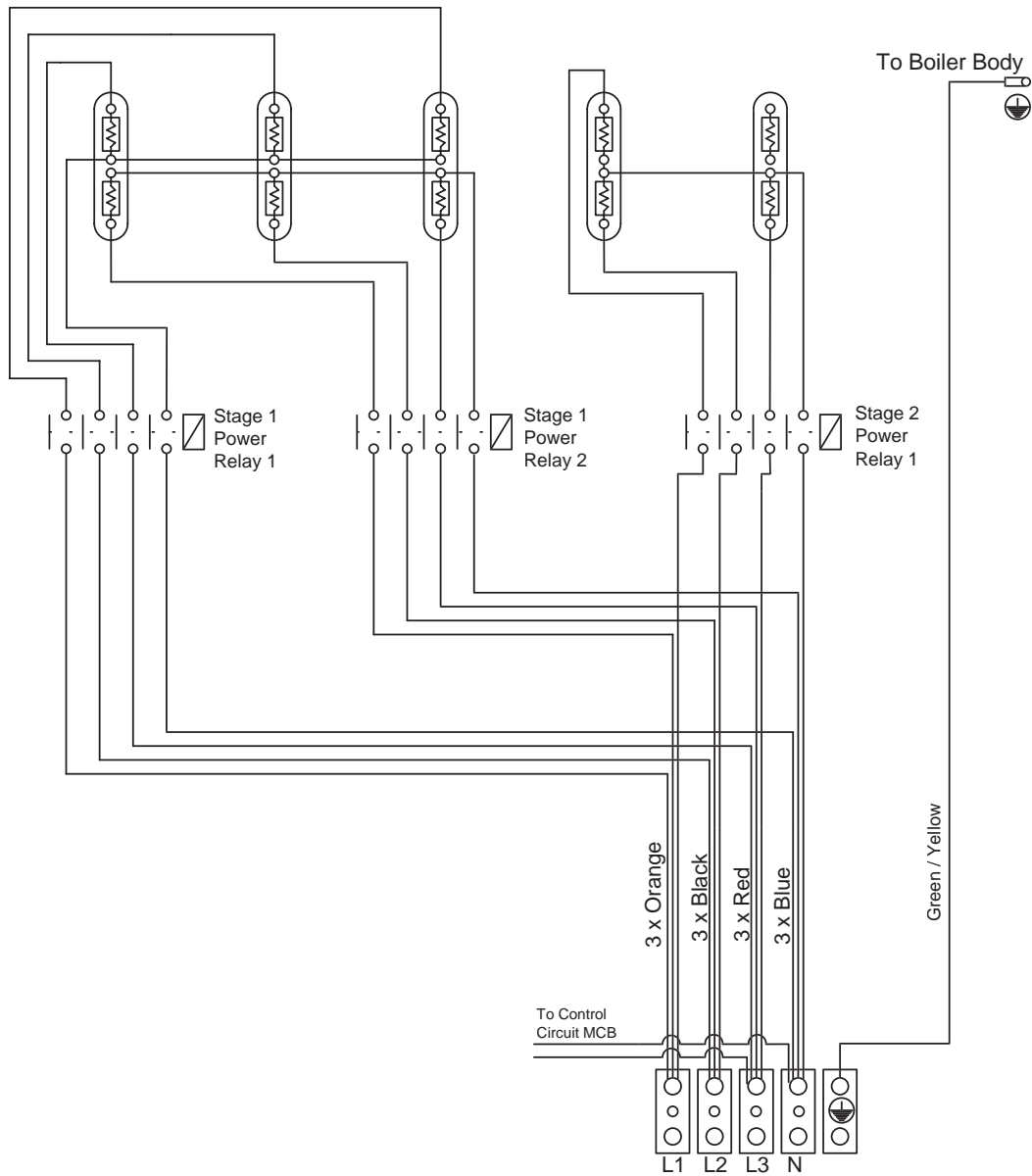

**PLEASE NOTE:** Due to the potential risk of ELECTRIC SHOCK this section of the manual is intended for use by a service engineer or qualified electrician, not the user.



# Honeywell Sundial Wiring Diagrams

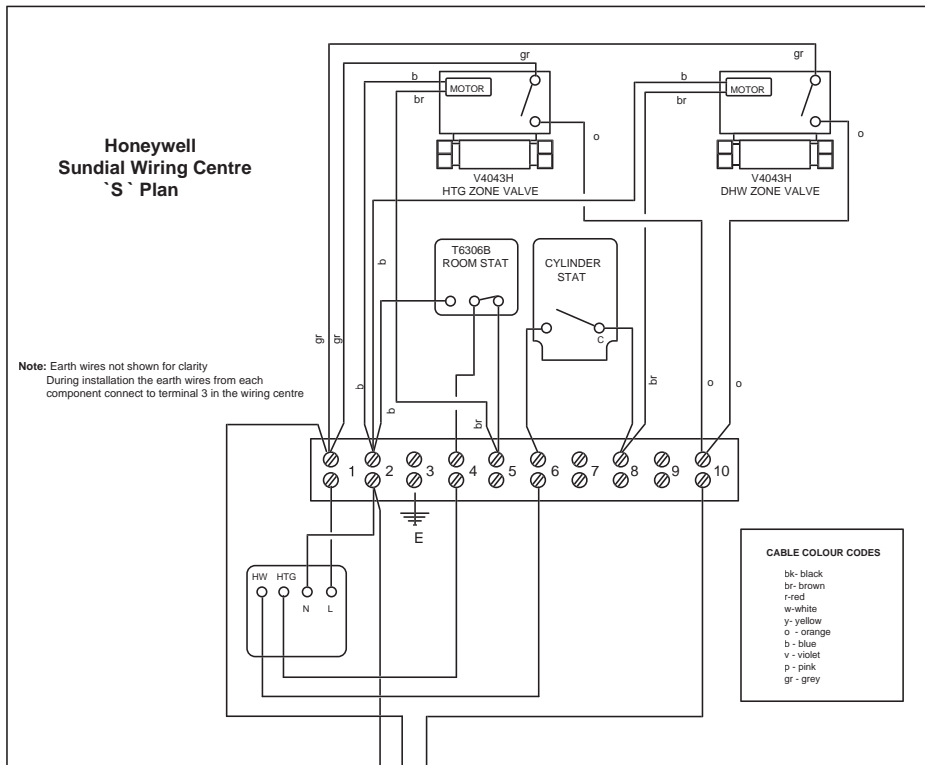

**Note:** All bold numbers indicate a DIN rail terminal connection

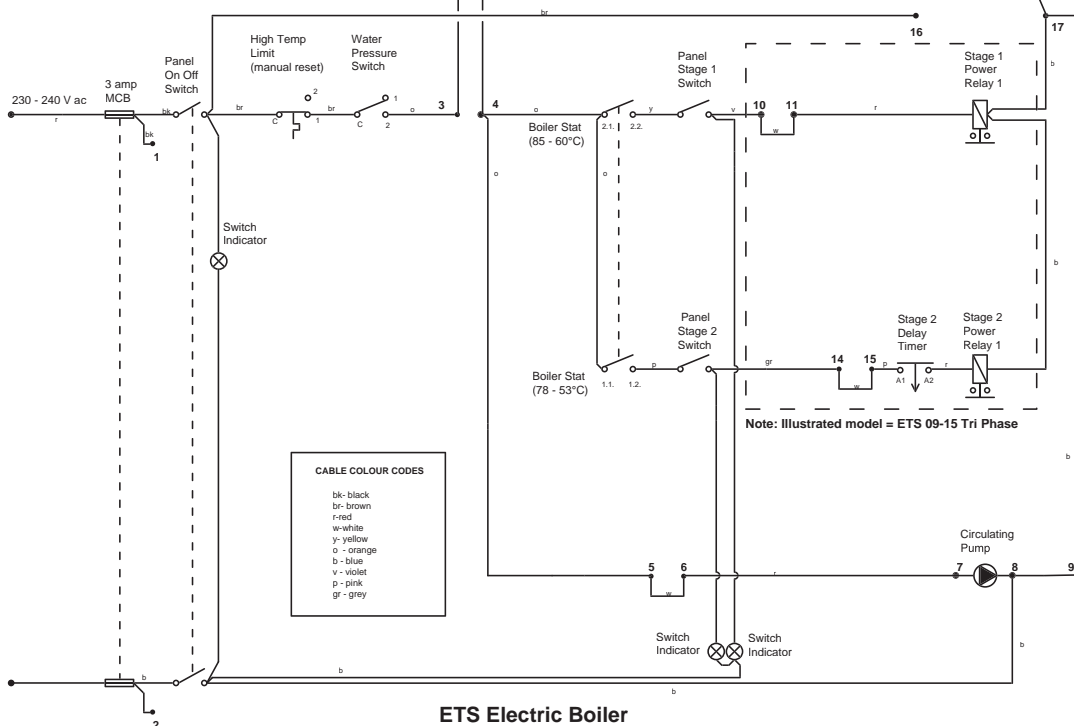

# Honeywell Sundial Wiring Diagrams

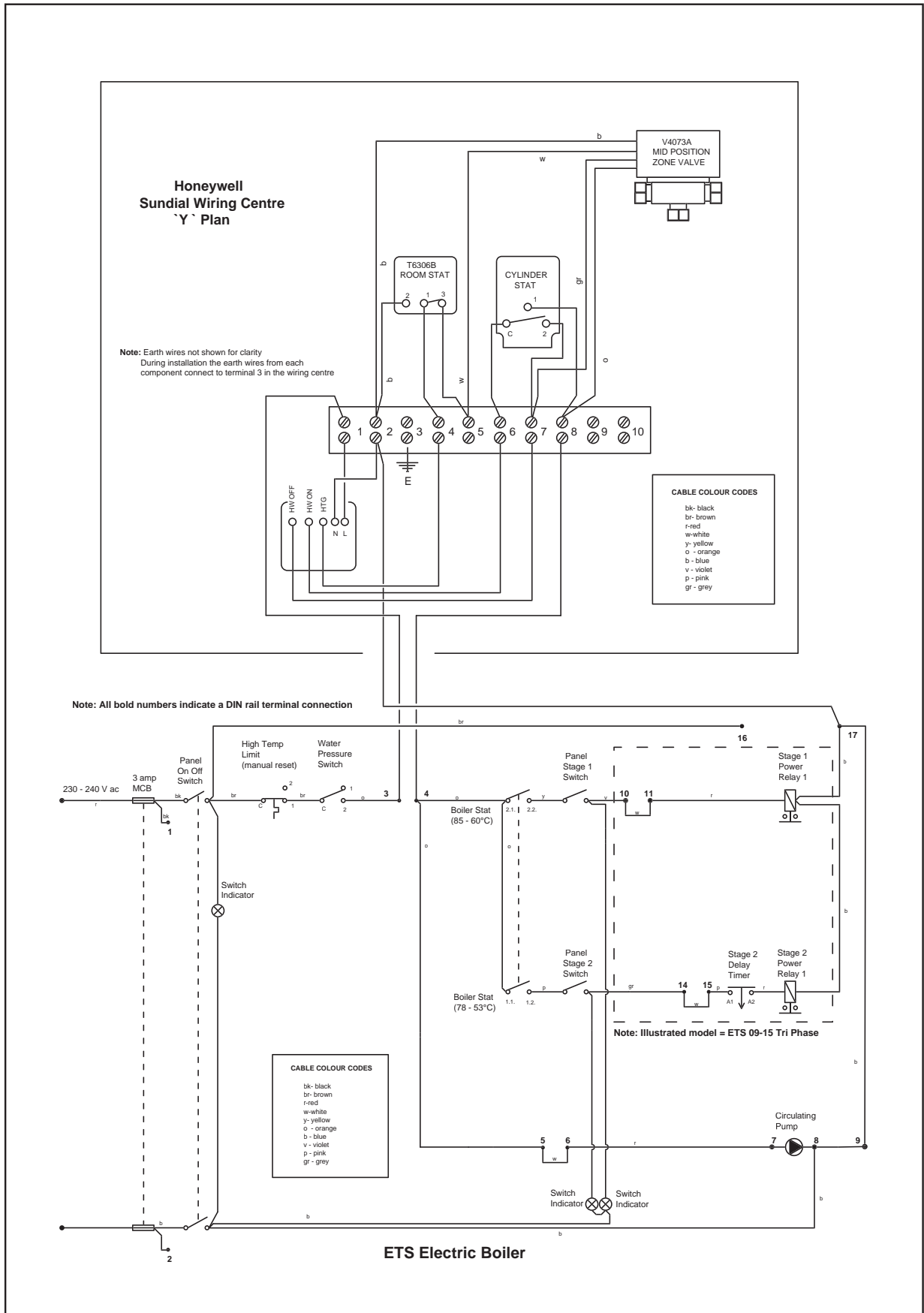

## FAULT FINDING ETS 09/15

Before carrying out any tests ensure voltage is present in the boiler and the timers calibration button B is set to minimum.

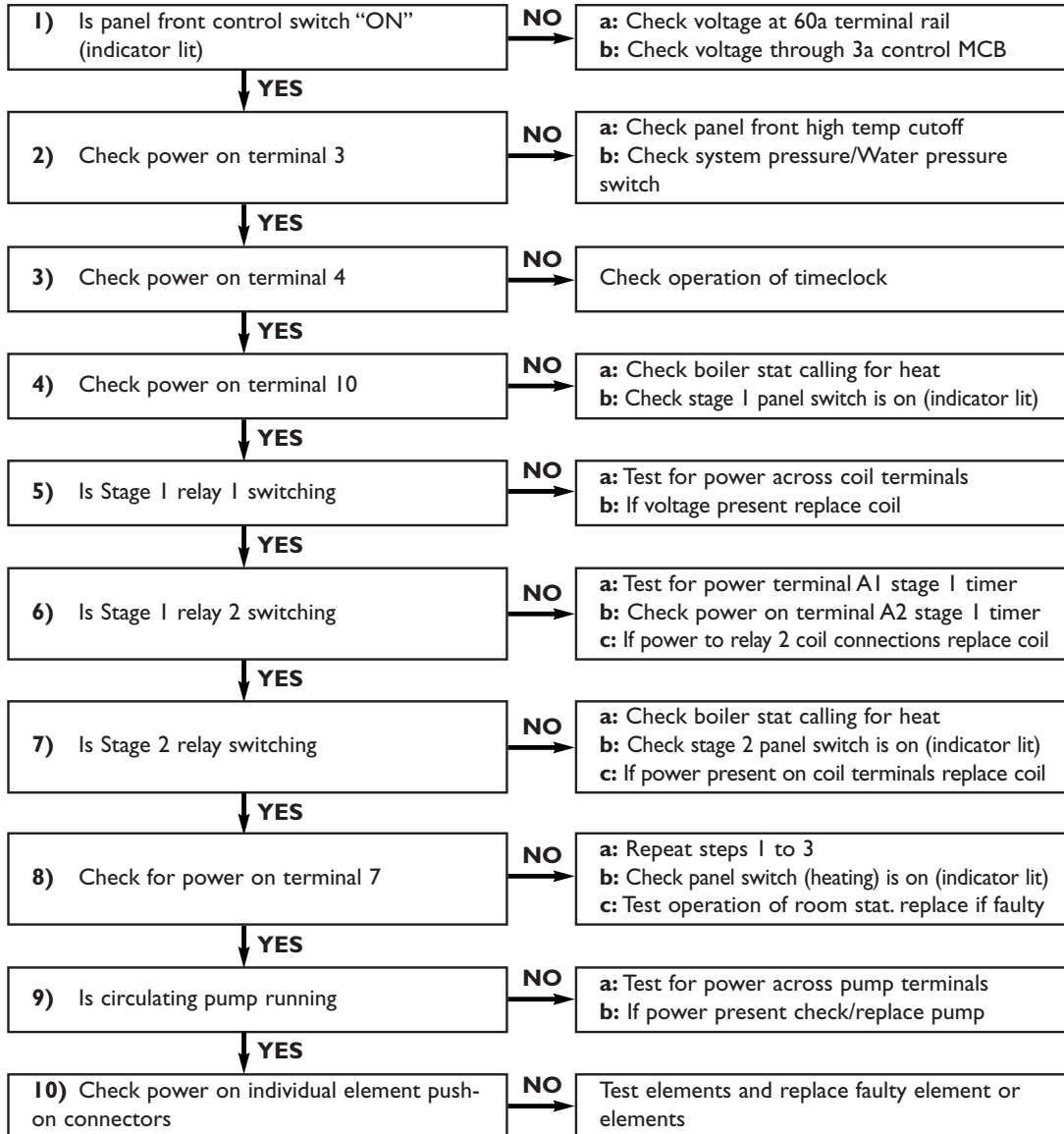

## FAULT FINDING ETS 24

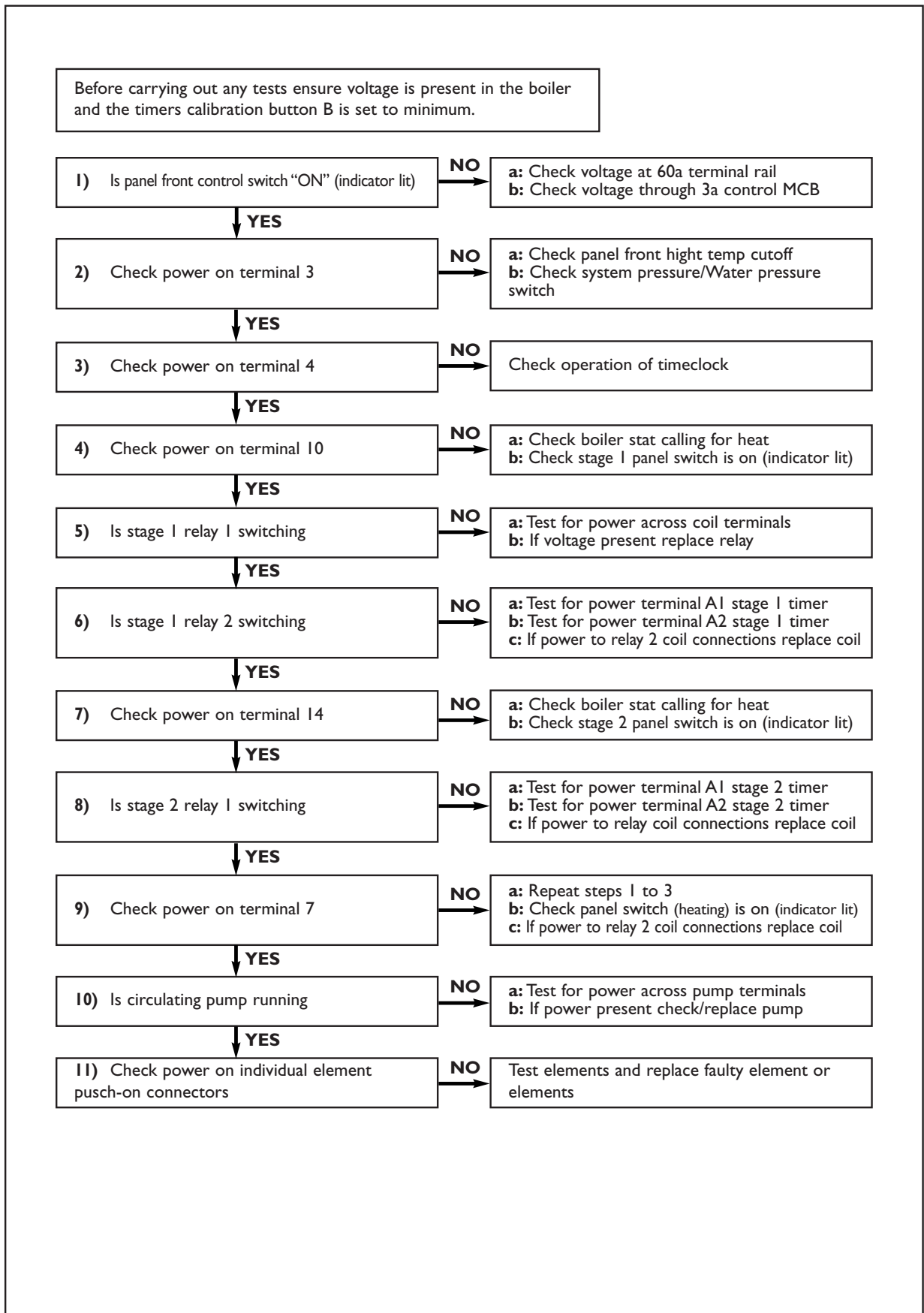

# MAINTENANCE

### Maintenance

For safety reasons it is recommended that the boiler is serviced annually and that servicing is carried out by a qualified service engineer.

Note: Before carrying out any work on the system ensure that the boiler is cool and all electrical supplies are isolated.

1. After removing front cover undo the four screws retaining the front control panel and gently let the panel suspend on the wiring to the rear of the panel. Undertake a visual inspection of the boiler looking out for signs of water leakage from joints, expansion vessel, and the area around the elements on top of the boiler.

2. Undertake a visual inspection of all cabling in the boiler casing checking for signs of overheating or burning.

3. Check all push-on electrical connectors for tightness and good connection to the relative components.

4. Using a correct fitting screwdriver check all electrical terminals on DIN rails and on all components for tightness.

5. Check the settings on the internal timers in accordance with the "Commissioning - Electrical" section.

6. Replace the control panel and the boiler front cover and refit screws.

7. Reinststate the electrical supply and follow the procedures set out in the commissioning section.

### SERVICE LOG

DATE	COMPANY	COMMENTS	INITIALS
		Initial commissioning visit	

**SERVICE LOG**

DATE	COMPANY	COMMENTS	INITIALS

---

**SERVICE LOG**

DATE	COMPANY	COMMENTS	INITIALS



*excellence in hot water*

www.acv-world.com

#### INTERNATIONAL

**ACV international n.v**  
KERKPLEIN, 39  
B-1601 RUISBROEK - BELGIUM  
TEL.: +32 2 334 82 20  
FAX: +32 2 378 16 49  
E-MAIL: international.info@acv-world.com

#### BELGIUM

**ACV BELGIUM nv/sa**  
KERKPLEIN, 39  
B-1601 RUISBROEK-BELGIUM  
TEL.: +32 2 334 82 40  
FAX: +32 2 334 82 59  
E-MAIL: belgium.info@acv-world.com

#### CHILE

**ALBIN TROTTER Y ACV LTDA**  
SAN PABLO 3800  
QUINTA NORMAL - SANTIAGO - CHILE  
TEL.: +56 2 772 01 69  
FAX: +56 2 772 92 62/63  
E-MAIL: chile.info@acv-world.com

#### CZECH REPUBLIC

**ACV CR SPOL. s.r.o**  
NA KRECKU 365  
CR-109 04 PRAHA 10 - CZECH REPUBLIC  
TEL.: +420 2 720 83 341  
FAX: +420 2 720 83 343  
E-MAIL: ceskarepublika.info@acv-world.com

#### DEUTSCHLAND

**ACV WÄRMETECHNIK GMBH & CO KG**  
GEWERBEGBIET GARTENSTRASSE  
D-08132 MÜLSEN OT. JACOB - DEUTSCHLAND  
TEL.: +49 37601 311 30  
FAX: +49 37601 311 31  
E-MAIL: deutschland.info@acv-world.com

#### ARGENTINA

**TECNO PRACTICA**  
ALFEREZ BOUCHARD 4857  
1605 CARAPACHAY - BUENOS AIRES  
TEL.: +54 11 47 65 33 35  
FAX: +54 11 47 65 43 07  
E-MAIL: jchas@tecnopractica.com

#### BRAZIL

**SIMETAL INDUSTRIA E COMERCIO DE FERRAMENTAS LTDA**  
RUA GERSON ANDREIS 535  
95112 - 130 CAXIAS DO SUL - BRAZIL  
TEL.: +55 54 227 12 44  
FAX: +55 54 227 12 26  
E-MAIL: export@simetal.com.br

#### BULGARIA

**PROXIMUS ENGINEERING LTD**  
7 BIAL KREM STR.  
9010 VARNA - BULGARIA  
TEL.: +359 52 500 070  
FAX: +359 52 301 131  
E-MAIL: info@proximus-bg.com

#### CHINA

**BEIJING HUADIAN HT POWER TECHNOLOGY DEVELOPMENT CO. LTD**  
ROOM B-912, TOWER B, COFCO PLAZA  
Nº. 8, JIANGUOMENNEI AVENUE  
BEIJING 100005 - PEOPLE'S REPUBLIC OF CHINA  
TEL.: +86 10 652 30 363/393 EXT 101  
FAX: +86 10 652 27 071  
E-MAIL: li.zheng@acv-world.com

#### DENMARK

**VARMEHUSET**  
FRICHSVEJ 40 A  
8600 SILKEBORG - DENMARK  
TEL.: +45 86 82 63 55  
FAX: +45 86 82 65 03  
E-MAIL: vh@varmehuset.dk

#### ESPAÑA

**ACV ESPAÑA**  
C/DE LA TEIXIDORA, 76  
POL. IND. LES HORTES  
E-08302 MATARÓ - ESPAÑA  
TEL.: +34 93 759 54 51  
FAX: +34 93 759 34 98  
E-MAIL: spain.info@acv-world.com

#### FRANCE

**ACV FRANCE sa**  
31, RUE AMPERE - Z.I MI - PLAINE  
F-69680 CHASSIEU - FRANCE  
TEL.: +33 4 72 47 07 76  
FAX: +33 4 72 47 08 72  
E-MAIL: france.info@acv-world.com

#### ITALIA

**ACV ITALIA**  
VIA PANA 92  
I-48018 FAENZA (RA) - ITALIA  
TEL.: +39 0546 64 61 44  
FAX: +39 0546 64 61 50  
E-MAIL: italia.info@acv-world.com

#### NEDERLAND

**ACV NEDERLAND bv**  
POSTBUS 350  
NL-2980 AJ RIDDERKERK - NEDERLAND  
TEL.: +31 180 42 10 55  
FAX: +31 180 41 58 02  
E-MAIL: nederland.info@acv-world.com

#### POLAND

**ACV POLSKA sp. z o.o.**  
UL. WITOSA 3  
87 - 800 WWOVCWAWEK - POLAND  
TEL.: +48 54 412 56 00  
FAX: +48 54 412 56 01  
E-MAIL: polska.info@acv-world.com

#### ESTONIA

**TERMOMX AS**  
TAHE 112A  
51013 TARTU - ESTONIA  
TEL.: +372 736 73 39  
FAX: +372 736 73 44  
E-MAIL: termomx@termomx.ee

#### GREECE

**ESTIAS**  
MARASLI STREET 7  
54248 THESSALONIKI - GREECE  
TEL.: +30 23 10 31 98 77 / +30 23 10 32 03 58  
FAX: +30 23 10 31 97 22  
E-MAIL: info@genikithermanson.gr

#### ÎLE MAURICE

**SOTRATECH**  
29, RUE MELDRUM  
BEAU BASSIN - ÎLE MAURICE  
TEL.: +230 46 76 970  
FAX: +230 46 76 971  
E-MAIL: stech@intnet.mu

#### LITHUANIA

**UAB "GILIUS IR KO"**  
SAVARNORIŲ PR. 192  
3000 KAUNAS - LITHUANIA  
TEL.: +370 37 308 930  
FAX: +370 37 308 932

#### MAROC

**CASATHERM**  
PLACE EL YASSIR  
20300 CASABLANCA - MAROC  
TEL.: +212 22 40 15 23  
FAX: +212 22 24 04 86

#### MOLDAVIA

**STIMEX - PRIM S.R.L.**  
STR BUCURESTI, 60A  
2012 CHISINAŪ - MOLDAVIA  
TEL.: +37 32 22 46 75  
FAX: +37 32 27 24 56  
E-MAIL: stimex@slavik.mldnet.com

#### PORTUGAL

**BOILERNOX LDA**  
RUA OUTEIRO DO POMAR  
CASAL DO CEGO, FRACÇÃO C,  
PAVILHÃO 3 - MARRAZES  
2400-402 LEIRIA - PORTUGAL  
TEL.: +351 244 837 239/40  
FAX: +351 244 823 758  
E-MAIL: boilernox@mail.telepac.pt

#### RUSSIA

**ACV RUSSIA**  
1/9, MALYI KISELNYI  
103031 MOSCOW - RUSSIA  
TEL.: +7 095 928 48 02 / +7 095 921 89 79  
FAX: +7 095 928 08 77  
E-MAIL: russia.info@acv-world.com

#### SLOVAK REPUBLIC

**ACV SLOVAKIA s.r.o.**  
PLUHOVÁ 49  
831 04 BRATISLAVA - SLOVAK REPUBLIC  
TEL.: +421 2 444 62 276  
FAX: +421 2 444 62 275  
E-MAIL: slovakia.info@acv-world.com

#### UK

**ACV UK Ltd**  
ST. DAVID'S BUSINESS PARK  
DALGETY BAY - FIFE - KY11 9PF  
TEL.: +44 1383 82 01 00  
FAX: +44 1383 82 01 80  
E-MAIL: uk.info@acv-world.com

#### USA

**TRIANGLE TUBE PHASE III**  
FREEWAY CENTER - 1 TRIANGLE LANE  
BLACKWOOD NJ 08012 - USA  
TEL.: +1 856 228 8881  
FAX: +1 856 228 3584  
E-MAIL: sales@triangletube.com

#### ÖSTERREICH

**PROTHERM HEIZUNGSTECHNIK GmbH**  
TRAUNJUFERSTRASSE 113  
4052 ANSFELDEN - ÖSTERREICH  
TEL.: +43 7229 804 82  
FAX: +43 7229 804 92  
E-MAIL: protherm@nexttra.at

#### ROMANIA

**SC TRUST EURO THERM SA**  
D.N. PIATRA NEAMT - ROMANIA  
km 2 C.P. 5 O.P. 3 jud. Neamt  
5600 PIATRA NEAMT - ROMANIA  
TEL.: +40 233 20 62 06  
FAX: +40 233 20 62 00  
E-MAIL: office@eurotherm.ro

#### SLOVENIA

**Z'MAJ d.o.o.**  
CESTA OF 49  
1420 TRBOVLJE - SLOVENIA  
TEL.: +386 356 32 830  
FAX: +386 356 32 831  
E-MAIL: jjeraj@zmaj.si

#### SWEDEN

**WÄRMEPRODUKTER I KLIPPAN AB**  
TEMPLAREGÅTAN 7  
26435 KLIPPAN - SWEDEN  
TEL.: +46 435 184 10  
FAX: +46 435 184 02  
E-MAIL: varmeprodukter.se@telia.com

#### TUNISIE

**SO.CO.ME CHAUMAX**  
BOÎTE POSTALE N°44  
1002 TUNIS - TUNISIE  
TEL.: +216 71 78 15 91  
FAX: +216 71 78 87 31

#### UKRAINE

**UKRTEPLOSERVICE LTD**  
PR. LAGUTENKO 14  
83086 DONETSK - UKRAINE  
TEL.: +38 062 382 60 47/48  
FAX: +38 062 335 16 89