

# delta pro & pro pack

*Installation, operating and  
maintenance instructions*



## IMPORTANT NOTES 3

Who should read these instructions	3
Symbols	3
Recommendations	3
Certification	3
Important notes	3

## DESCRIPTION 4

Working principle	4
Standard equipment	4
Optional equipment	4
Construction features	4
Description of the boiler	4

## USER GUIDE 6

Use of the boiler	6
Heating circuit pressure	6
Getting to know the control panel	6
Oil or gas burner lockout	7

## TECHNICAL CHARACTERISTICS 8

General	8
Maximum operating conditions	8
General characteristics	8
Domestic hot water performance	8
Burner chamber plate for oil or blown gas burner	8
Dimensions	9

## INSTALLATION 10

Boiler room	10
Optional balanced flue connection kit	10
B23 flue connection	10
Type of flue connection	11
Flue connection accessories	13
Domestic hot water connection	14
Heating connection	15
ACV BMV burner oil supply	16
ACV BG 2000-S burner gas supply	16

## ELECTRICAL CONNECTION 17

Electrical connection of the boiler	17
-------------------------------------	----

## OPTIONAL CONTROLS 18

Installing a high or low temperature heating system with Control Unit	18
---	----

## BMV OIL BURNER FEATURES 20

Description of the BMV oil burner	20
BMV oil burner settings	20

## BG 2000-S GAS BURNER FEATURES 21

ACV BG 2000-S premix burner	21
BG 2000-S gas burner settings	21
Gas categories	22

## COMMISSIONING AND MAINTENANCE 24

Filling the hot water and heating circuits	24
Boiler commissioning	24
Recommendation	24
Boiler maintenance	24
Burner maintenance	24
Maintenance of safety devices	24
Draining of the boiler	24
Draining the heating circuit	24
Draining the DHW circuit	24

## SPARE PARTS at the end of the instructions

## WHO SHOULD READ THESE INSTRUCTIONS

These instructions should be read by:

- the design engineer/consultant
- the user
- the installer
- the service engineer

## SYMBOLS



Essential instruction for the correct operation of the installation



Essential instruction for the safety of persons and the environment



Electrocution hazard:  
use a qualified technician



Burn hazard

## RECOMMENDATIONS



- Carefully read this manual before installing and bringing the boiler into service.
- It is prohibited to modify the interior of the appliance in any way, without the manufacturer's prior written agreement.
- The boiler must be installed by a qualified engineer, in accordance with the applicable local standards and codes.
- Failure to follow the instructions describing test operations and procedures could result in personal injury or a risk of environmental pollution.
- In order to ensure the appliance operates safely and correctly, it is important to have it serviced by an approved contractor.
- If there is a problem please contact your contractor for advice.
- In spite of the strict quality standards that ACV applies to its appliances during production, inspection and transport, faults may occur. Please notify your approved contractor immediately of any faults.
- Defective parts can only be replaced with original factory parts. You will find a list of spare parts and their ACV reference number at the end of this manual.
- BG 2000-S gas burners are pre-adjusted in the factory for natural gas [equivalent to G20].
- Specific regulation in Belgium:  
The CO<sub>2</sub>, gas flow, air flow and air/gas supply parameters are adjusted in the factory and cannot be changed in Belgium.



- Before carrying out any work on the boiler, it is important to isolate the electrical supply to the unit.
- The user must not attempt to gain access to the components inside the boiler or the control panel.

## CERTIFICATION

The products have received EC certification in accordance with the standards in force in various countries (European Directives 92/42/EEC "efficiency requirements", 90/396/EEC "appliances burning gaseous fuels"). These products have also been awarded the Belgian "HR+" (gas boiler) and "OPTIMAZ" (oil boilers) labels.



## IMPORTANT NOTES

### IF YOU SMELL GAS:

- Isolate the gas supply immediately.
- Ventilate the room (Open the windows).
- Do not use electrical appliances and do not operate switches.
- Notify your gas supplier and/or your installer immediately.

These instructions are an integral part of the equipment to which they relate and must be left for the user.

The product is to be installed and serviced by qualified technicians, in accordance with current regulations.

The manufacturer declines all liability for any damage caused as a result of incorrect installation or in the event of the use of appliances or accessories that are not specified by the manufacturer.



The manufacturer reserves the right to change the technical characteristics and features of its products without prior notice.



The availability of certain models as well as their accessories may vary according to markets.

## WORKING PRINCIPLE

The **Delta Pro** boiler is a high performance hot water producer using indirect heat transfer due to its Tank-in-Tank technology.

At the centre of the **Delta Pro** there is a stainless steel cylinder through which the flue tubes pass. It is surrounded by a mild steel shell containing the primary water (neutral fluid). The outer shell extends down to the combustion chamber and also surrounds the flue gas tubes. The heat exchange surface is therefore larger than that of traditional direct fired hot water boilers.

The gas or oil burner heats the primary fluid which indirectly heats the stainless steel cylinder containing the hot water. As with all Tank-in-Tank systems, the cylinder is corrugated over its full height and suspended in the boiler by its hot and cold water connections.

The fact that the cylinder expands and contracts as it is used and that cold water is not in contact with the intense heat of the burner flame prevents scale formation. This resistance to scale, along with the anti-corrosion properties of the stainless steel mean that sacrificial anodes are not needed.

The **Delta Pro** has a major advantage over other hot water boilers: it heats hot water with a primary circuit, which allows the primary fluid to also be used for heating.

## STANDARD EQUIPMENT

**DELTA PRO MODELS 25/45/55 HAVE THE FOLLOWING COMPONENTS AS STANDARD:**

- on/off switch
- summer/winter selector
- thermostat adjustable from 60 °C to 90 °C
- temperature-pressure gauge
- limit thermostat (auto-reset) 95 °C
- manual reset safety thermostat 103 °C
- primary safety valve 3 Bar
- hot water safety valve 7 Bar
- drain down valve
- body fully insulated with rigid polyurethane foam

**DELTA PRO PACK MODELS 25/45 HAVE THE FOLLOWING COMPONENTS AS STANDARD:**

- on/off switch
- summer/winter selector
- thermostat adjustable from 60 °C to 90 °C
- temperature-pressure gauge
- limit thermostat (auto-reset) 95 °C
- manual reset safety thermostat 103 °C
- primary safety valve 3 Bar
- hot water safety valve 7 Bar
- manual four-way valve (servomotor available as an option)
- circulator with automatic air eliminator
- primary expansion tank 10 litre
- hot water expansion tank 2 litre
- drain down valve
- body fully isolated with rigid polyurethane foam

## OPTIONAL EQUIPMENT

**DELTA PRO 25/45 & PRO PACK 25/45**

- Balanced flue kit (*except for Delta Pro 55*)
- Control Unit kit (*Delta Pro Pack only*)
- Servomotor (*Delta Pro Pack only*)

## CONSTRUCTION FEATURES

### CASING

The boiler is covered by a steel casing which has been scoured and phosphated before being stove enamelled at 220 °C.

### BOILER BODY

The boiler body containing the primary fluid is constructed with STW 22 steel. This is tested at a pressure of 4.5 bar (maximum service pressure = 3 bar).

### TANK-IN-TANK ACCUMULATOR/HEAT EXCHANGER

The internal ring-shaped inner tank is constructed from Chrome/Nickel 18/8 stainless steel and has a large heat exchange surface area to quickly heat the water. It is corrugated over its height by an exclusive manufacturing process and is entirely argon arc welded using the TIG (Tungsten Inert Gas) method.

### COMBUSTION GAS CIRCUIT

This includes:

- **The flue tubes:**  
The different **DELTA Pro** models include, depending on their power, 4 or 8 steel flue tubes with an internal diameter of 64 mm. Each tube is equipped with a stainless steel turbulator designed to improve thermal exchange and reduce flue gas temperature.
- **The sealed combustion chamber:**  
The combustion chamber of all the **DELTA Pro** models is entirely water cooled.

### INSULATION

The boiler body is fully insulated by rigid polyurethane foam with a high coefficient thermal insulation, sprayed-on without the use of CFCs.

## DESCRIPTION OF THE BOILER

**DELTA PRO 25/45/55 & PRO PACK 25/45 MODELS**

1. Flue reduction collar with easy access for servicing
2. Rigid polyurethane foam insulation
3. PVCC dip tube with cold water diffuser
4. Control thermostat and thermometer bulb
5. Burner chamber plate with refractory ceramic fibre insulation
6. 95 °C cut-off thermostat and manual reset safety thermostat bulb
7. Flue tubes
8. Turbulators
9. Stainless steel "Tank-in-Tank" hot water cylinder
10. Primary circuit (heating)
11. Combustion chamber
12. Boiler base
13. Heating flow
14. Heating return
15. Domestic hot water outlet
16. Domestic cold water supply
17. Primary hot water safety valve [7 bar]
18. Primary heating safety valve [3 bar]
19. Flue connection Ø 100 mm
20. Drain down valve

**DELTA PRO PACK 25/45 MODELS**

21. Hot water expansion tank [2 litres]
22. Heating circulator with built-in automatic air eliminator
23. Four-way mixer valve (optional motor)
24. Heating expansion tank [10 litres]

## Delta Pro 25/45/55 models

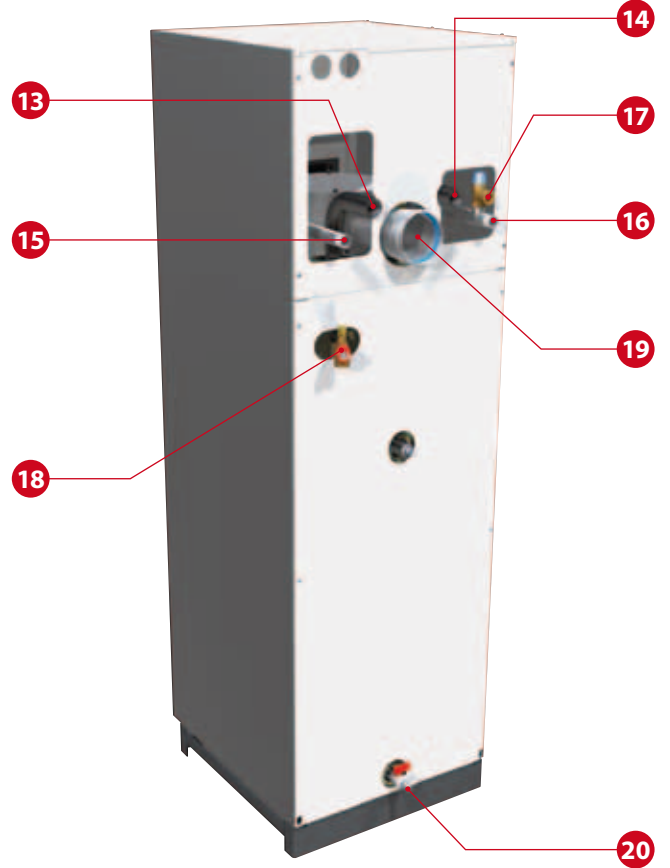
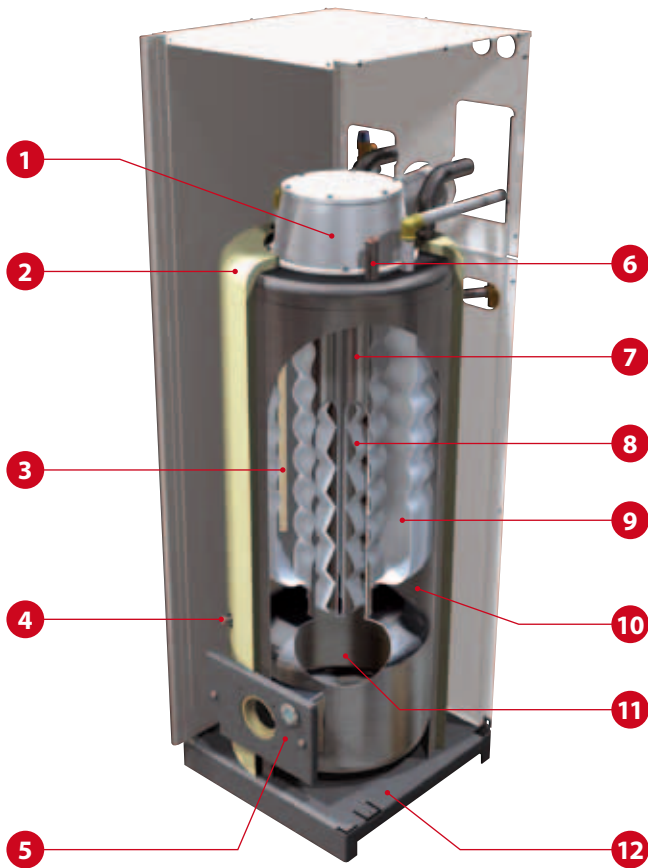

## Delta Pro Pack 25/45 models

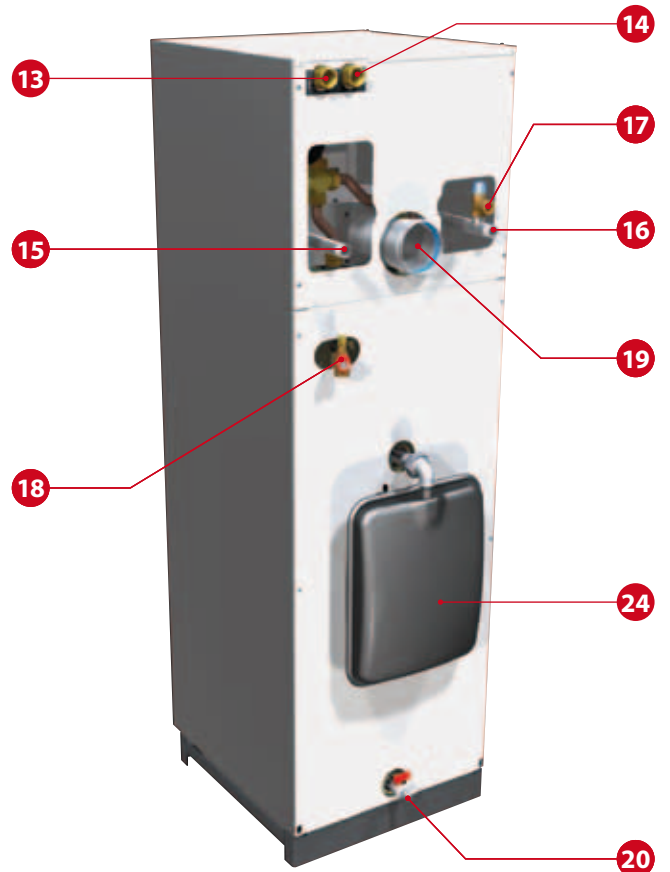
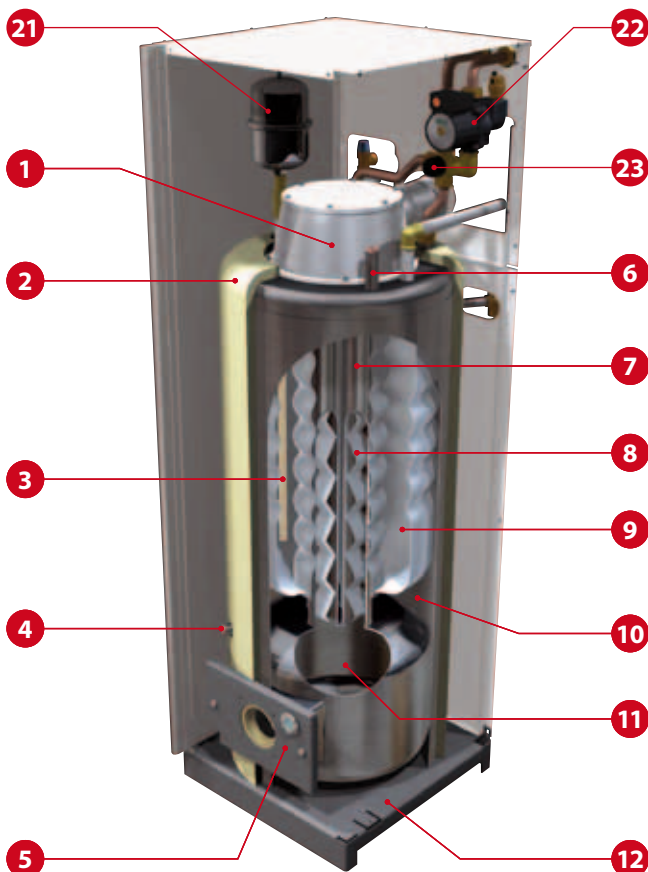

## USE OF THE BOILER



Please get your system serviced every year by a qualified technician. More frequent servicing may be required depending on boiler use. If this is the case, consult your installer for advice.

### Starting the burner:

In normal operation, the burner starts automatically as soon as the boiler drops below the temperature setpoint.



Before the boiler is serviced, switch off the electrical supply with the external isolator. Also switch the general switch on the control panel to "OFF".

## HEATING CIRCUIT PRESSURE

The heating circuit pressure must be at least 1 bar and must be regularly checked by the end user. Always make sure that the appliance is off when refilling the system. To do this, use the ON/OFF switch. For further information, please contact your installer.

A safety valve is provided under the appliance. If the pressure of the installation exceeds 3 bars, this valve opens and water from the system is drained off. If this happens, please contact your installer.



Water from the safety valve may be extremely hot and cause very severe burns.

## GETTING TO KNOW THE CONTROL PANEL

### 1 - Control thermostat

If the boiler is only used for producing hot water, the boiler temperature may be adjusted between 60 °C and 90 °C.

If the boiler is used for hot water and heating, the boiler's control thermostat will generally be set to 80 °C for optimum operating conditions.

### 2 - General switch

This switch is used for starting and shutting down the boiler.

### 3 - Summer/Winter selector

This is used to turn the heating circulator on and off (if connected directly to boiler wiring).

### 4 - Temperature-pressure gauge

This gauge displays the boiler temperature and the pressure inside the primary circuit. The temperature should not exceed 90 °C. If it is higher than this, the boiler should be shut down and the thermostat settings checked. If the problem persists, call a technician. The pressure should not fall below 1 bar. If it does, consult the "Heating system pressure" paragraph further on in this section.

### 5 - ACV controller (optional)

Refer to the controller instructions if you have this option.

### 6 - Manual reset safety thermostat

If the boiler temperature exceeds 103 °C, this safety device will shut down the boiler and the overheat warning light will come on. To restart, the boiler temperature must fall below 60 °C. Unscrew the cover and press the restart button using a pen or a similar pointed object, then replace the cover. If the problem persists, turn the boiler off and call a technician.





## OIL OR GAS BURNER LOCKOUT

The safety warning light on the burner indicates an operational fault. Wait five minutes and then reset the burner by pressing the "RESET" button on the burner.

If the burner does not restart, call a technician after making sure that it is not a power cut or that the oil/gas is off.



ACV BMV1 (FV) & BMV2 (FV) oil burners



If the oil or gas burner is not working, turn off the power to the boiler using the external isolator before resetting the safety thermostat on the control panel.



Manual reset safety thermostat



Wait until the boiler temperature is below 60 °C before switching on.

If the problem persists, please contact your installer.

### Starting the burner:

In normal operation, the burner starts automatically as soon as the boiler drops below the temperature setpoint.



To make sure your system works correctly, please have it serviced every year by a qualified technician before the heating season.

## REPAIRING THE BURNER

For all burners, please refer to the servicing and repair sections in the burner manual.

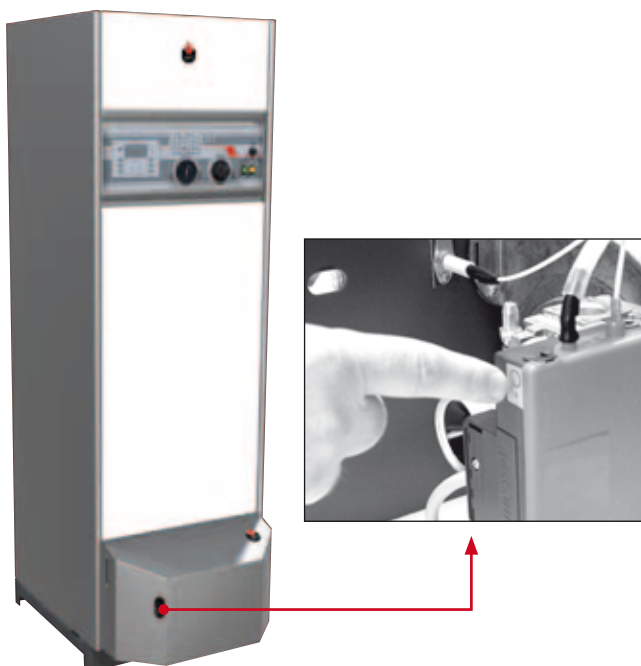

ACV BG 2000-S premix gas burners

# TECHNICAL CHARACTERISTICS

## GENERAL

The units are delivered fully assembled, tested and packed on a timber base with shockproof edges; the package is protected by a heat-shrunk plastic film. Upon receipt and after unpacking, check the equipment for transport damage. For transport purposes, refer to the dimensions and weights given below:

## MAXIMUM OPERATING CONDITIONS

### Maximum service pressure (tank full of water)

- Heating circuit: 3 bar
- Hot water circuit: 10 bar

### Test pressure (tank full of water)

- Heating circuit: 4.5 bar
- Hot water circuit: 13 bar

### Operating temperature

- Maximum temperature: 90°C

### WATER QUALITY

- Chlorides: < 150 mg/l

- $6 \leq \text{ph} \leq 8$

## BURNER CHAMBER PLATE [OIL OR BLOWN GAS]

The burner chamber plate has 4 threads (M 8) for attaching the burner. It is protected from heat by a blanket insulation.

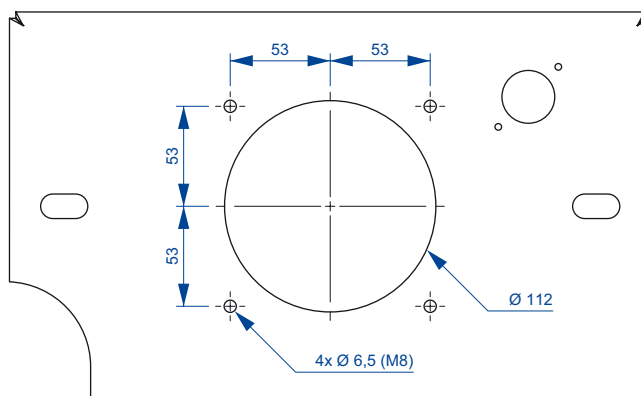

## GENERAL CHARACTERISTICS

		Delta Pro & Pro Pack 25	Delta Pro & Pro Pack 45	Delta Pro 55
Input power [Input]	<b>kW</b>	27,9	50,0	61,0
Useful nominal power [output]	<b>kW</b>	26,0	45,0	55,0
Max. useful output 80/60°C	<b>%</b>	89,6	90	90,1
Total capacity	<b>L</b>	158	127,5	151
Primary capacity	<b>L</b>	83	62,5	68
Heating connection	<b>Ø</b>	1" [F]	1" [F]	1" [F]
Domestic hot water connection	<b>Ø</b>	3/4" [M]	3/4" [M]	3/4" [M]
DHW cylinder heat exchange surface	<b>m<sup>2</sup></b>	1,59	1,99	2,46
Heating circuit pressure drop	<b>mbar</b>	15	25	37
Flue gas circuit pressure drop	<b>mbar</b>	0,25	0,30	0,45

## DOMESTIC HOT WATER PERFORMANCE

		Delta Pro & Pro Pack 25	Delta Pro & Pro Pack 45	Delta Pro 55
<b>System operating at 80°C</b>				
Peak flow rate at 40°C [ΔT = 30°C]	<b>L/10'</b>	268	316	362
Peak flow rate at 40°C [ΔT = 30°C]	<b>L/60'</b>	806	1284	1533
Continuous flow rate at 40°C [ΔT = 30°C]	<b>L/h</b>	645	1161	1405
<b>Tank refill time at 60°C</b>				
Initial heating time	<b>Minutes</b>	32	16	16
After drawing off 140 litres at 45 °C	<b>Minutes</b>	15	9	7



## DIMENSIONS

	A [mm]	B [mm]	C [mm]	D [mm]	E [mm]	F [mm]	ØG [mm]	H [mm]	I [mm]	J [mm]	K [mm]	L [mm]	M [mm]	Kg (*)
<b>Delta Pro 25</b>	1760	540	584	1386	360	200	100	220	1445	1445	928	1400	—	145
<b>Delta Pro 45</b>	1760	540	584	1386	390	200	100	220	1445	1445	928	1400	—	168
<b>Delta Pro 55</b>	1760	540	584	1586	390	200	100	220	1645	1645	928	1600	—	200
<b>Delta Pro Pack 25</b>	1760	540	584	1386	360	63	100	220	1723	1445	—	1400	128	145
<b>Delta Pro Pack 45</b>	1760	540	584	1386	390	63	100	220	1723	1445	—	1400	128	168

(\*) Empty weight without burner

Delta Pro 25/45/55

Delta Pro Pack 25/45

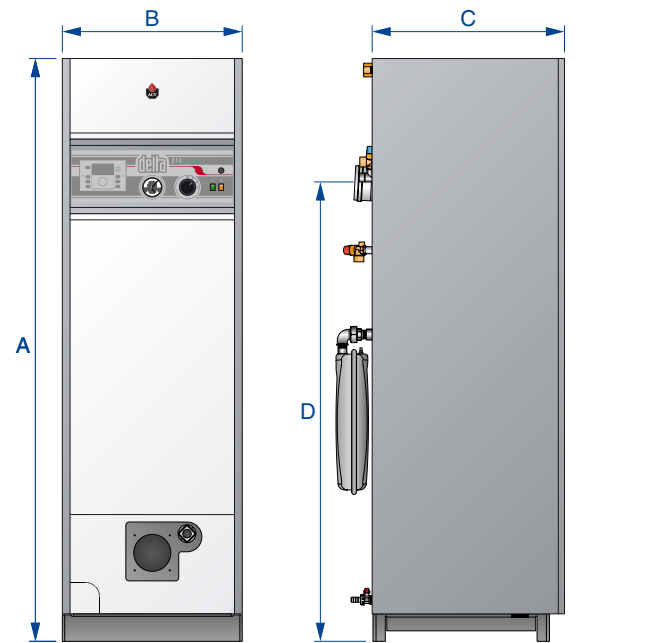
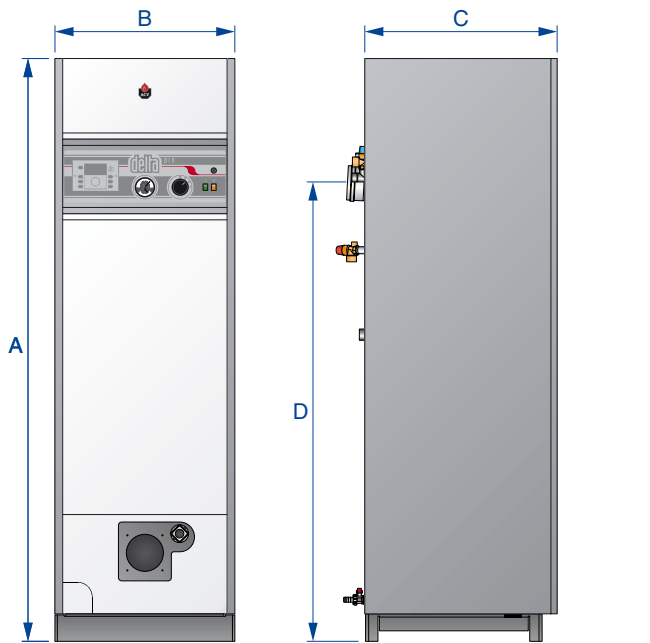

## BOILER ROOM

- The flue connection must be carried out in compliance with the standards in force, for example NBN D51-003, taking account of local energy supplier and fire regulations as well as regulations relating to "noise pollution".
- Make sure that all air vents are unobstructed.
- Do not store flammable products in the boiler room.
- Make sure that corrosive products, such as paint, solvents, chlorine, salt, soap and other cleaning products, are not stored near to the boiler.
- The boiler must be placed on a non-combustible surface.

### Accessibility

The boiler room must be large enough to allow good access to the boiler. The following minimum distances are required around the boiler: (500 mm in front, 200 mm to the sides, 150 mm behind and 700 mm above).

## OPTIONAL BALANCED FLUE CONNECTION KIT

Delta Pro balanced flue (code: 10800194)

Available only for Delta Pro & Pro Pack 25/45 models.

### Balanced flue kit components:

### Codes

One upper rear casing	<b>21479456</b>
One silicon hose	<b>49437026</b>
One balanced flue adapter Ø 100/150 mm	<b>507F3047</b>
One brass nipple	<b>53437039</b>
One Master-Neo hose Ø 80 mm — L. 2,300 mm	<b>537D6171</b>
One PVC collar Ø 80/50 mm	<b>537D6092</b>
One PPS collar Ø 100/80 mm	<b>537D6172</b>
One elbow Ø 80 mm	<b>537D6352</b>
One measuring unit with condensate collector Ø 100/150 mm	<b>537D6226</b>



## B23 FLUE CONNECTION



### IMPORTANT:

The boiler is to be installed by a qualified engineer, in accordance with current regulations.



The diameter of the Flue must not be smaller than that of the boiler's flue reduction collar.

### Boiler room ventilation

The boiler room must be fitted with top and bottom vents.



The tables below give the values defined according to Belgian regulations.

Given that regulations vary from one country to the next, these tables are given for information only.

Each installer must ensure that boiler room ventilation complies with current regulations.

### Design of boiler room ventilation [See page 12]

	Min. fresh air requirement m <sup>3</sup> /h	Top vent [A] dm <sup>2</sup>	Bottom vent [B] dm <sup>2</sup>	Draught regulator [C] Ø mm
<b>Delta Pro &amp; Pro Pack 25</b>				
BMV1	37	1,5	1,5	100
BG 2000-S/25	37	1,5	1,5	100
<b>Delta Pro &amp; Pro Pack 45</b>				
BMV2	66	1,5	1,5	100
BG 2000-S/45	66	1,5	1,5	100
<b>Delta Pro &amp; Pro Pack 55</b>				
BMV2	80	1,5	1,8	100
BG 2000-S/55	80	1,5	1,8	100

### Flue diameter

	Height 5 m Ø mm	Height 10 m Ø mm	Height 15 m Ø mm
<b>Delta Pro &amp; Pro Pack 25</b>			
BMV1	120	100	100
BG 2000-S/25	120	100	100
<b>Delta Pro &amp; Pro Pack 45</b>			
BMV2	160	140	125
BG 2000-S/45	160	140	125
<b>Delta Pro &amp; Pro Pack 55</b>			
BMV2	180	150	135
BG 2000-S/55	180	150	135

## TYPE OF FLUE CONNECTION

- B23** : Connection to a flue with the combustion air taken directly in the boiler room.
- B23P** : Connection to an exhaust system of the combustion products designed to operate with positive pressure.
- C13** : Connection by pipes with horizontal terminals that simultaneously take in combustion air for the burner and discharge combustion products outside through openings that are either concentric or close enough together to be subjected to similar wind conditions.
- C33** : Connection by pipes with vertical terminals that simultaneously take in fresh air for the burner and discharge the combustion products outside through openings that are either concentric or close enough together to be subjected to similar wind conditions.
- C43** : Connection by two ducts to a collective duct system serving more than one appliance; this system of collective ducts features two ducts connected to a terminal unit that simultaneously takes in fresh air for the burner and discharges the combustion products outside through openings that are either concentric or close enough together to be subjected to similar wind conditions. **[Only if the boiler is fitted with an ACV BG 2000-S premix boiler].**

- C53** : Connection to separate ducts for the supply of combustion air and for venting the combustion products; these ducts may end in zones with different pressure levels. **[Only if the boiler is fitted with an ACV BG 2000-S premix boiler].**
- C83** : Connection with single-line or dual-line system. This system comprises a flue with normal outlet to discharge the combustion products. The appliance is also connected by a second line with a terminal, which takes in fresh air for the burner from outside the building. **[Only if the boiler has an ACV BG 2000-S premix burner].**



**Due to the high efficiency of our boilers, the flue gases are released at low temperature. As a result, there is a risk of condensation in these flue gases, which could damage some flues. To avoid this risk, it is strongly recommended to line the flue and allow for condensate removal. Please contact your installer for more information.**

Models	Burners	Connection type						
		B23	B23P	C13	C33	C43	C53	C83
Delta Pro 25 / 45 / 55	BMV	●						
Delta Pro Pack 25 / 45								
Delta Pro 25 / 45	BMV / FV	●		●	●			
Delta Pro Pack 25 / 45								
Delta Pro 25 / 45	BG 2000-S	●	●	●	●	●	●	●
Delta Pro Pack 25 / 45								
Delta Pro 55	BG 2000-S	●	●					
Delta Pro 25 / 45	BG 2000-SV	●	●	●	●	●	●	●
Delta Pro Pack 25 / 45								



**For concentric connection, the total length of the flue must be no more than 6 metres and no less than 1 metre (including the terminal).**

**For double pipe connection (only with gas) :**  
**Gas = 10 metres + 4 pipe bends**

## Flue connection options

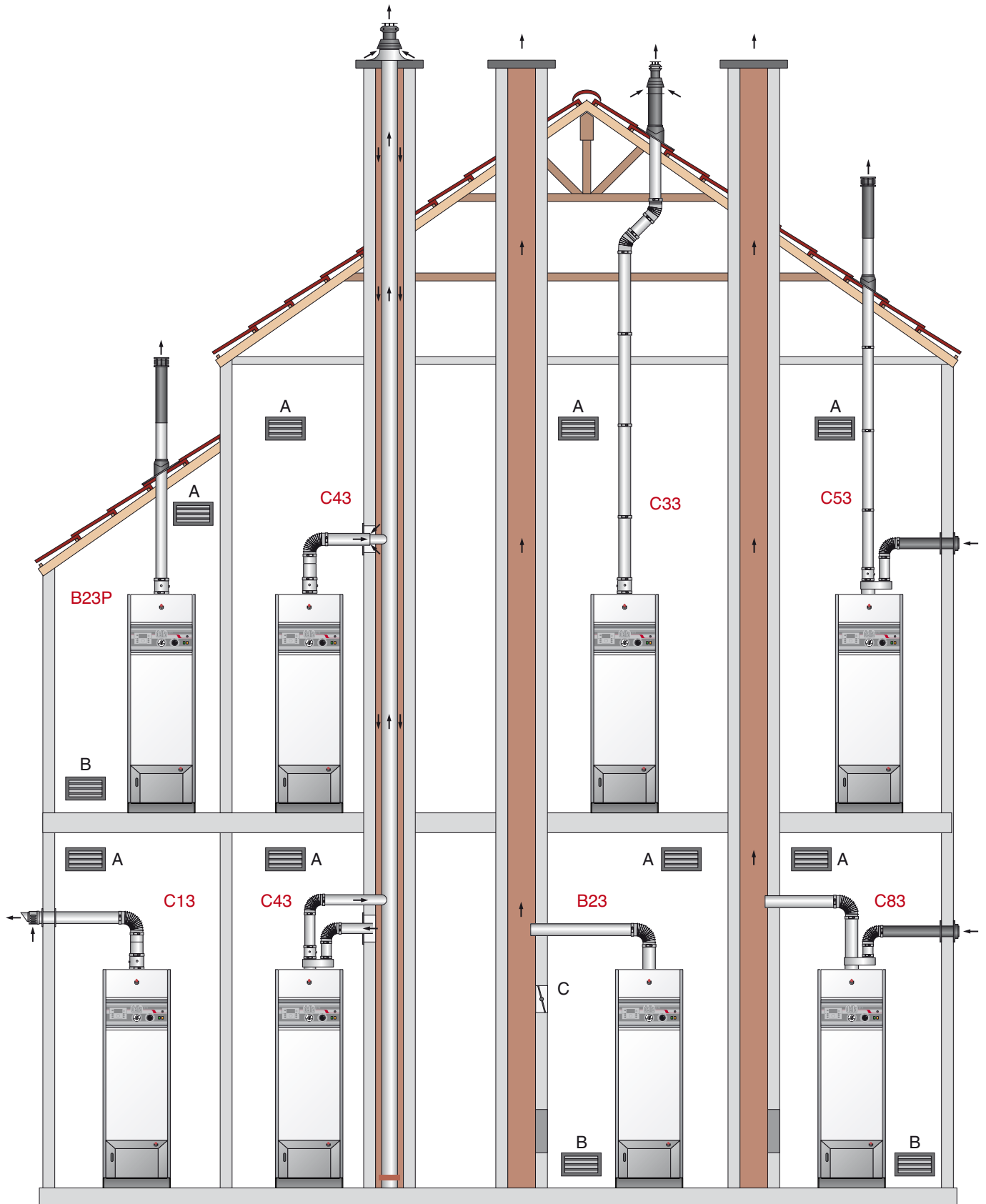

## FLUE CONNECTION ACCESSORIES

Concentric Stainless steel - Stainless steel Ø 100/150 mm

### A TERMINALS

Code	Item	SIZE
537D6197	Vertical terminal	1515 mm
537D6198	Horizontal terminal with wall plates	795 mm

### B DUCTS

Code	Item	SIZE
537D6199	Length 250 mm	210 mm
537D6200	Length 500 mm	460 mm
537D6201	Length 1000 mm	960 mm

### C ADJUSTABLE DUCT

Code	Item
537D6202	Length adjustable from 325 to 400

### D PIPE BENDS

Code	Item
537D6203	43°-45° bend
537D6204	87°-90° bend

### E CONDENSATION MEASURING AND COLLECTION DEVICE

Code	Item	SIZE
537D6226	Condensate collector and measuring tube	140 mm

### F ACCESSORIES

Code	Item	SIZE
537D6208	Flat roof flashing (base Ø 430 mm)	110 mm
537D6209	Adjustable flashing	
537D6210	Attachment Ø 150 mm	

### G ADAPTER

Code	Item	SIZE
537D6207	Parallel concentric adapter Ø 100/150 mm - 2 x Ø 100 mm	205 mm

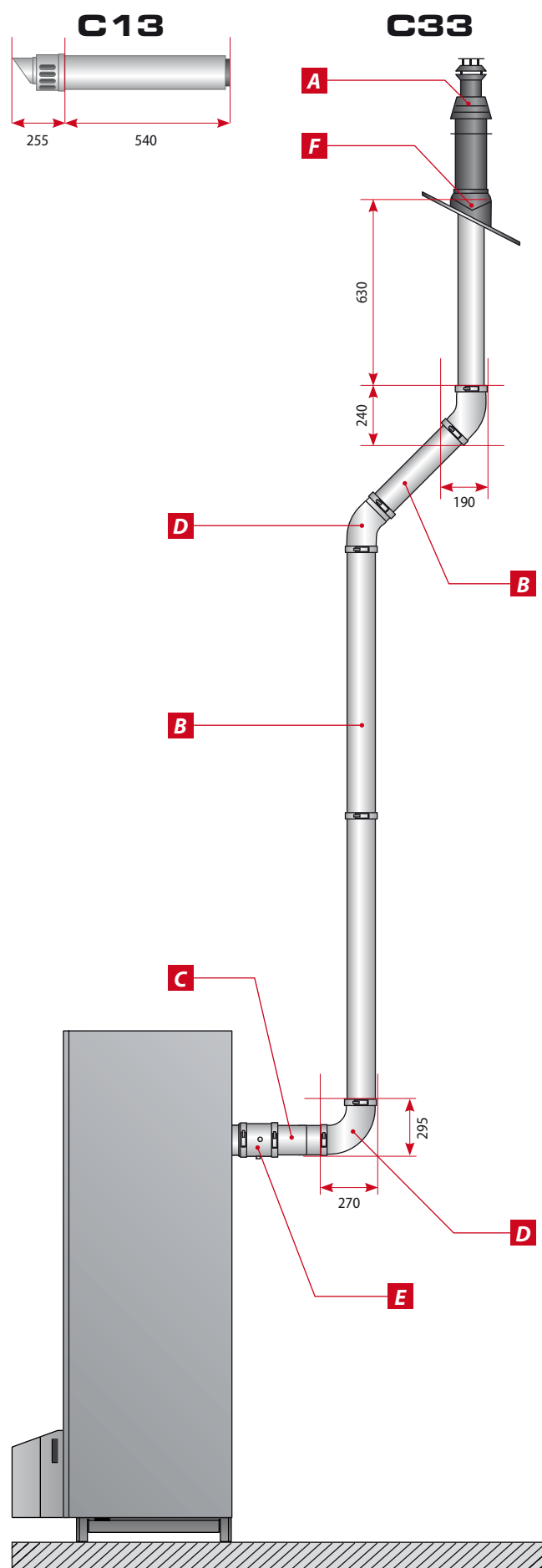

## DOMESTIC HOT WATER CONNECTION

### EXAMPLE OF CONNECTION WITH THERMOSTATIC MIXER VALVE

1. 7 bar hot water safety valve (as standard)
2. Pressure reducer
3. Temperature control valve
4. Hot water circulator (optional)
5. Non-return valve
6. Hot water expansion tank (as standard on Pro Pack, 2 litres)
7. Cold water feed valve
8. Hot water outlet
9. Drain down valve
10. Syphon valve
11. Isolating valve

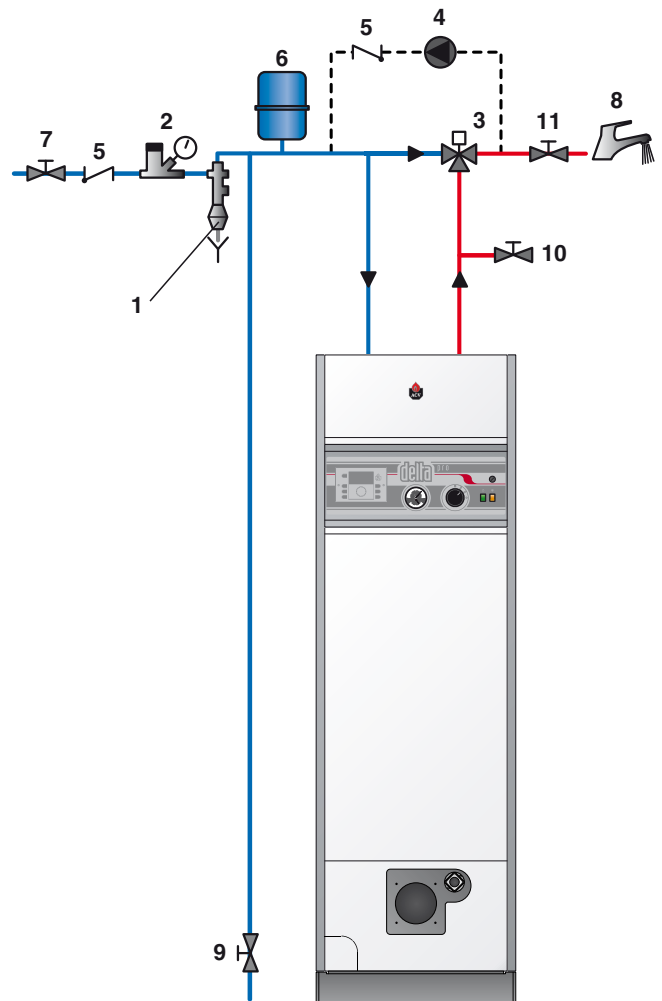

#### IMPORTANT

It is essential that the DHW cylinder is filled and pressurised before filling the heating circuit.

#### Pressure reducer

If the water mains pressure is greater than 6 bar, a pressure reducer calibrated to at least 4.5 bar must be fitted (UK regulations apply).

#### Hot water safety valve

The hot water safety valve is at 7 bar; valve discharge must be connected to drain (UK regulations apply).

#### Hot water expansion tank (as standard on Pro Pack, 2 litres)

Installing a hot water expansion tank avoids any risk of pressure surges due to water hammer or pressure variations.

#### Optional hot water circulation

If the tank is situated a long way from the point of use, then installing a closed return circuit can provide a faster supply of hot water at all times.



#### IMPORTANT

As a safety measure against burns, we strongly recommend installing a thermostatic mixer.

### Optional fittings available

Pressure reducer	Ø 3/4"
Temperature mixing valve	Ø 3/4"
Expansion tank	5 litres



If there is a risk of low pressure in the hot water circuit (installation of a Delta Pro & Pro Pack on the roof of a building), it is essential to install a vacuum breaker device onto the cold water supply.



## HEATING CONNECTION

### EXAMPLE OF A BASIC CIRCUIT CONNECTION

1. Four-way motorisable mixer valve (as standard on Pro Pack)
2. Circulator (as standard on Pro Pack)
3. Heating isolating valve
4. System filling valve
5. 3 bar heating safety valve (as standard)
6. Primary expansion tank (as standard on Pro Pack)
7. Control unit (optional)
8. Drain down valve (as standard)

### DRAIN VALVE

The safety valves must be connected to the drain.



### DELTA PRO PACK HYDRAULIC KIT

This hydraulic kit is factory assembled on **Delta Pro Pack 25** and **Delta Pro Pack 45** models comprising:

- A circulator with automatic air eliminator built in.
- A four-way manual motorisable valve (servomotor available as an option).
- A primary 10 litre expansion tank.
- A hot water 2 litre expansion tank.

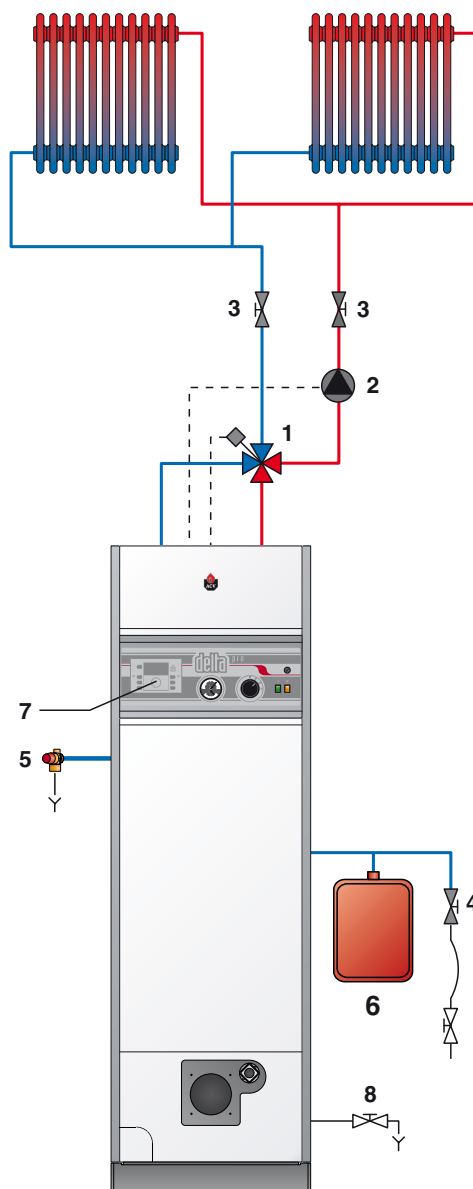

## OIL SUPPLY FOR ACV BMV BURNERS

Supply construction and installation must be in accordance with current regulations.

The oil pipe must be brought sufficiently close to the burner so that the hoses can be connected without stretching. On the supply side of the line, fit a filter with a quick closing valve.

### Oil supply with return

Height H	Ø 6 mm	Ø 8 mm	Ø 10 mm
0,0 m	17 m	53 m	100 m
0,5 m	15 m	47 m	100 m
1,0 m	13 m	41 m	199 m
1,5 m	11 m	34 m	184 m
2,0 m	19 m	28 m	168 m
2,5 m	17 m	22 m	153 m
3,0 m	15 m	15 m	137 m
3,5 m	13 m	19 m	122 m

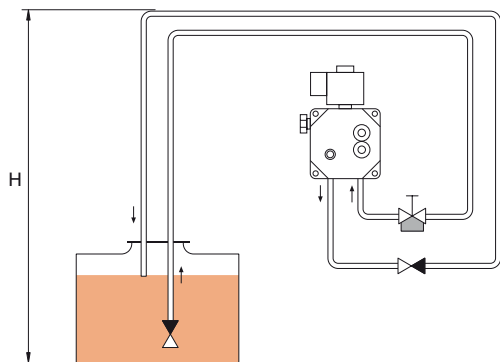

For further information regarding the oil supply, please consult the technical manual supplied with the burner.



If a different burner is installed, please refer to the manufacturer's technical manual.

## GAS SUPPLY FOR ACV BG 2000-S BURNERS

- The **Delta Pro & Pro Pack** boilers combined with an **ACV BG 2000-S** burner have a  $\text{Ø } 3/4''$  [F] gas connection for connection of a gas supply valve.
- The gas connections must comply with all applicable standards (in Belgium: NBN D51-003).
- If there is a risk of dirt stemming from the gas network, place a gas filter upstream of the connection.
- Purge the gas pipe and carefully check that there are no leaks on the boiler's internal and external pipes.
- Check the system's gas pressure. Please refer to the technical data table.
- Check the gas pressure and consumption when commissioning the appliance.

## ELECTRICAL CONNECTION

### SUPPLY PRINCIPLE

The boiler uses a single phase supply at 230 V - 50 Hz. A mains isolator with 6A mcb (5A fuse) must be fitted outside the boiler to allow the power to be shut off during servicing and before any repairs are carried out.

### COMPLIANCE

The installation must comply with current regulations.

### SAFETY

The hot water circuit must be connected separately to earth.



The power to the boiler must be isolated before any work is carried out on it.

1. Boiler supply
2. On/off switch
3. Safety thermostat [103°C max.]
4. Summer/winter selector
5. Control thermostat [60/90°C]
6. Cut-off thermostat [95°C max.]
7. Connection terminal
8. Burner connection plug [7 pin]
9. Room thermostat connection (optional)
10. Connection of the heating circulator [optional except for on Pro Pack]

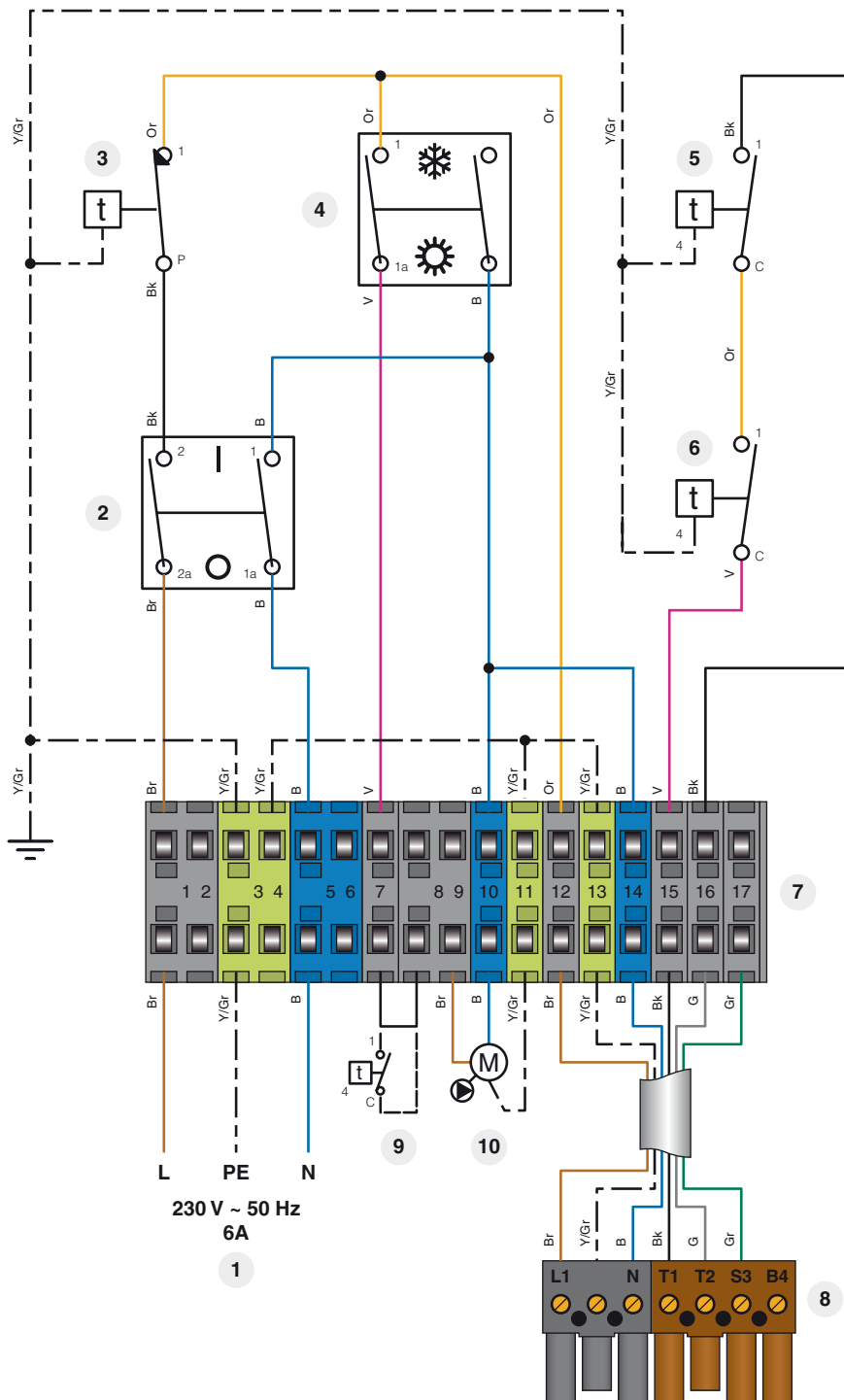

- B. Blue
- Br. Brown
- Bk. Black
- G. Grey
- Gr. Green
- Or. Orange
- V. Violet
- Y/Gr. Yellow/Green

## INSTALLATION OF A HIGH OR LOW HEATING CIRCUIT WITH CONTROL UNIT

### SCHEMATIC DIAGRAM

The heating (high temperature or floor heating) is controlled by the AF200 outside temperature detector supplied with the Control Unit and by the RFF room detector or RS Zone Unit.





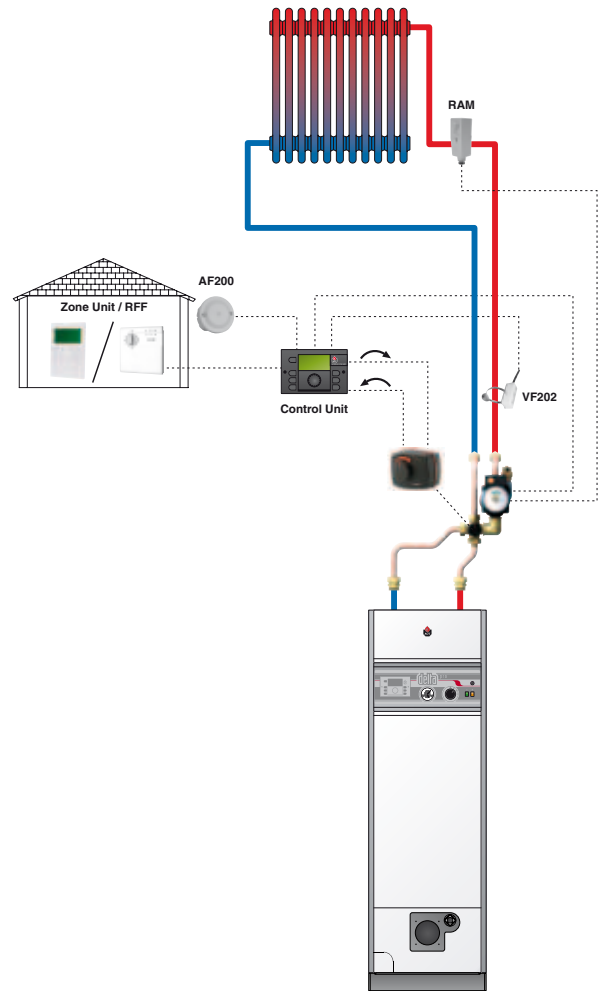

The detectors are connected to a controller that can be built into the boiler.

This controller operates the four-way valve and the circulator depending on requirements (calculated from the outside temperature) and on the start temperature measured by a third detector.

- The system provides a high level of comfort as the start temperature is constantly adapted to heating requirements.
- Built-in timer with setting of heating times (day) and lower temperature times (night).
- The room detector allows the user to adjust the comfort setpoint to their specific requirements.



### Equipment required as options

	Codes	Descriptions
	10800030	Control Unit : Supplied with an AF200 outside detector and a 2 kΩ KVT bulb sensor
	10800108	AF200 2 kΩ outside temperature sensor : Included with control unit
	10800056	RS Zone Unit : Remote control + room sensor
ou 	10800120	RTF room sensor
	10800045	VF202 2 kΩ contact sensor : For outlet on controlled circuit
	10510900	RAM 5409 contact thermostat : Obligatory to protect floor heating circuits
	10800199	ARA661 servomotor : Motor for four-way valve

Wiring diagram for the intermediate base for connection to the Control Unit

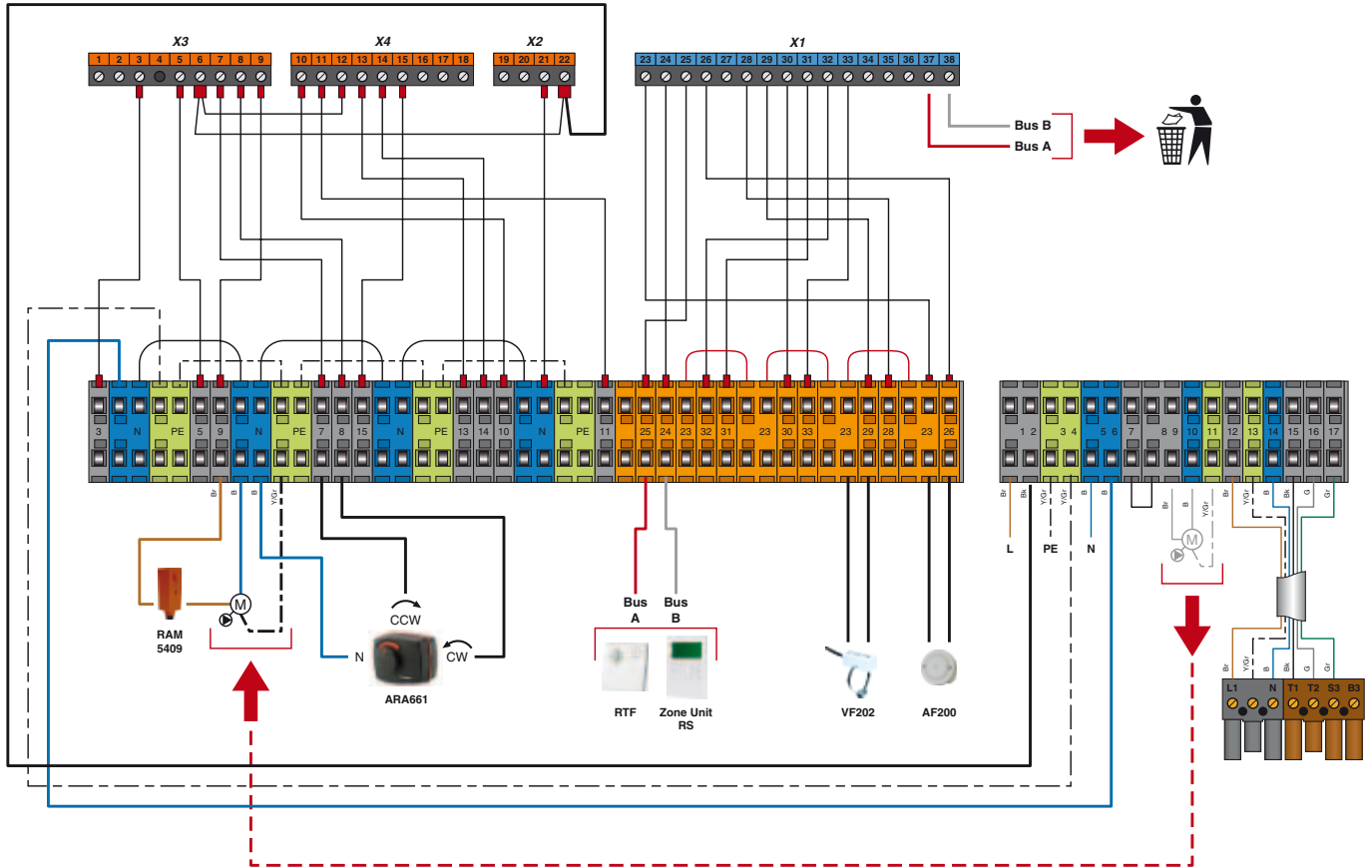

Control Unit hydraulics menu

Parameters	Descriptions
P02	OFF
P04	OFF
P05	OFF

Menu chauffage du Control Unit

Parameters	Descriptions
P01	OFF

# BMV OIL BURNER FEATURES

## DESCRIPTION OF THE BMV OIL BURNER

For our **DELTA Pro & Pro Pack** boilers, we have opted for the latest technology of **ACV BMV1** and **BMV2** boilers, which involves a third-generation transparent flame burner. The advantages of this burner construction lie in operation saving the maximum amount of energy with very low emissions of harmful substances (approval according to EN 267:1999-11, category 3, the German 'Blue Angel' environmental label, according to RAL-UZ 9, approval in accordance with the Swiss Air Purity Act (LRV) a fan that can withstand extreme pressure and a structure that is easy to service. We draw your attention to the fact that installation, commissioning and servicing should be carried out by a specialist company. These installation and servicing instructions contain important information on this subject. To make sure the system operates at all times in such a way as to save energy and release few harmful substances, we recommend that you have your burner inspected every year by a specialist company.



For further information, please consult the technical manual supplied with the burner.

## BMV OIL BURNER SETTINGS

Burner		Delta Pro & Pro Pack 25		Delta Pro & Pro Pack 45		Delta Pro 55
		BMV1	BMV1 FV	BMV2	BMV2 FV	BMV2
Input power	<b>kW</b>	27,9	27,9	50,0	50,0	61,0
Nozzle	<b>Gal/h</b>	0,60	0,60	1,25	1,25	1,35
Nozzle angle		45° H	45° H	60° H	60° H	60° H
Oil flow	<b>kg/h</b>	2,35	2,35	4,22	4,22	5,14
Pump pressure	<b>bar</b>	12	12	10	10	11
Air reducer	<b>%</b>	25 - 30	—	67 - 72	—	90 - 95
Air inlet	<b>%</b>	30 - 35	24 - 28	57 - 62	75 - 80	88 - 93
Nozzle line	<b>mm</b>	6 - 8	6 - 8	12 - 14	13 - 15	17 - 19
Blast tube pressure	<b>mbar</b>	2,0 - 2,5	2,0 - 2,5	2,2 - 2,7	2,0 - 2,5	2,8 - 3,3
Flue gas temperature net value	<b>°C</b>	138	138	164	164	140

1. Control box
2. Nozzle line protection
3. Electrical connection
4. Attachment bracket
5. Blast tube
6. Ignition unit
7. High-voltage ignition cables
8. Oil pump
9. Oil supply line connection
10. Oil return connection
11. Motor condenser
12. Motor
13. Pump/nozzle connecting pipe
14. Indication lamp / reset button
15. Burner casing
16. Nozzle line adjustment screw
17. Air reducer (except BMV1 FV and BMV2 FV)
18. Air inlet

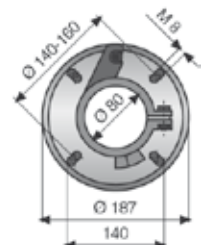
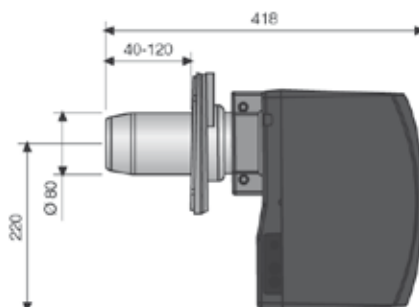
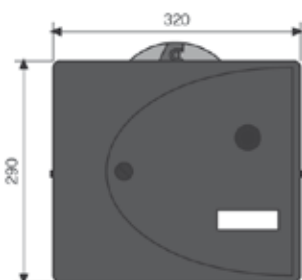
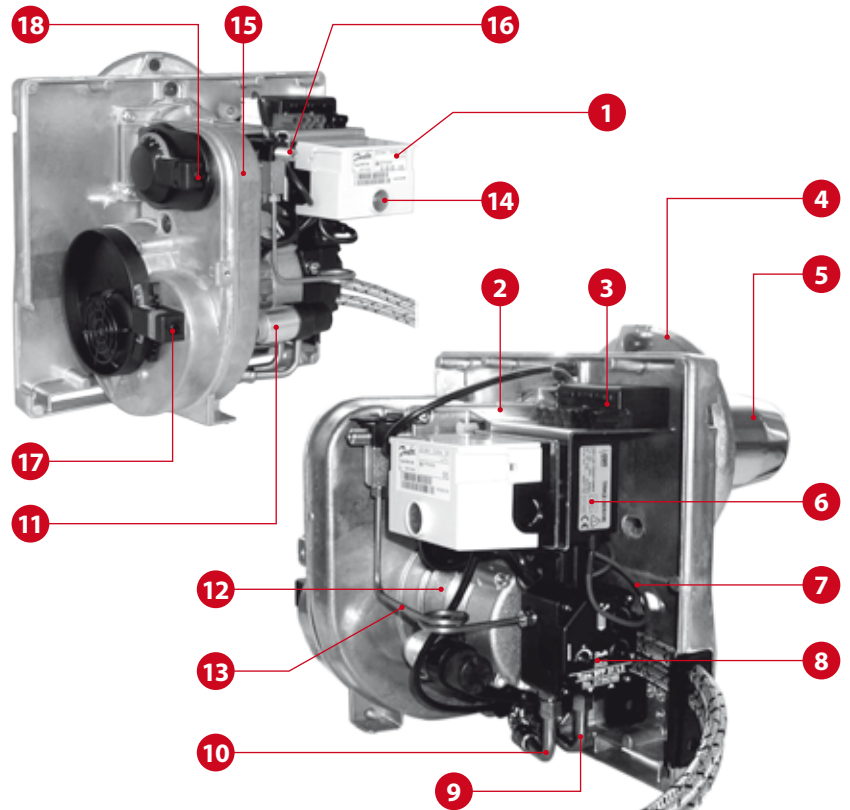



## ACV BG 2000-S PREMIX GAS BURNER

The **BG 2000-S** air/gas premix burner has a Honeywell gas valve, a venturi tube and an electric control relay. The gas valve has been specially designed for low NOx air/gas premix burners with automatic ignition and ionisation flame detection.

The output pressure of the gas valve is equal to the air pressure at the neck of the venturi tube, less the limit of the offset adjustment. The fan takes in the combustion air through the venturi tube into which the gas inlet opens. As it passes through, the air creates a differential across the neck of the venturi tube and draws in the gas at the venturi tube outlet. A perfect air/gas mix passes through the fan and is then to the burner tube.

The electric control relay attached to the gas valve ensures that the burner flame is ignited and controlled correctly.

This principle guarantees safe and quiet operation:

- In the event of low air flow, the differential across the venturi tube falls, the gas flow rate diminishes, the flame extinguishes and the gas valve closes: the burner is then in lockout.
- In the event of flue blockage or restriction, the air flow rate falls, then the same reactions as those described above causing burner lockout.

### Air/gas mix control principle

- A. Air
- B. Gas
- C. Venturi tube
- D. Fan
- E. Air – Gas mix
- F. Offset adjustment screw
- G. Gas flow rate adjustment screw

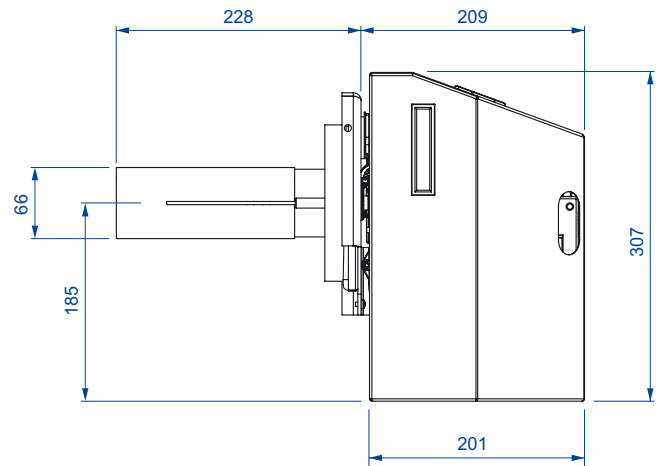
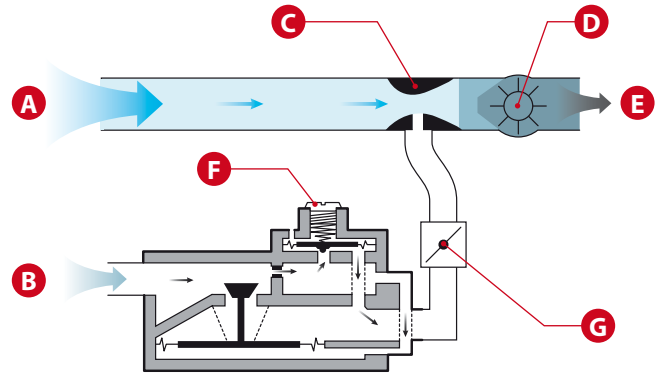

The BG 2000-S burner is preset in the factory for natural gas.

**Conversion to propane: PROHIBITED IN BELGIUM.**  
Conversion kit attached to the burner including:  
- Cover plate.  
- Information plate.  
- Settings sticker.  
- Installation instructions.

## GAS BURNER SETTINGS

Burner		Delta Pro & Pro Pack 25		Delta Pro & Pro Pack 45		Delta Pro 55
		BG 2000-S/25	BG 2000-SV/25	BG 2000-S/45	BG 2000-SV/45	BG 2000-S/55
Input power	<b>kW</b>	27,9	27,9	50,0	50,0	61,0
CO <sub>2</sub> natural gas	<b>%</b>	9,0	9,0	9,0	9,0	9,0
CO <sub>2</sub> propane	<b>%</b>	11,0	11,0	11,0	11,0	11,0
Gas connection	<b>Ø</b>	3/4" [F]	3/4" [F]	3/4" [F]	3/4" [F]	3/4" [F]
Fan speed	<b>rpm</b>	3400	3400	4400	4400	4100
Gas flow rate [G20 - 20 mbar]	<b>m<sup>3</sup>/h</b>	2,95	2,95	5,29	5,29	6,45
Gas flow rate [G25 - 25 mbar]	<b>m<sup>3</sup>/h</b>	3,43	3,43	6,15	5,29	7,51
Gas flow rate [G31 - 37/50 mbar]	<b>m<sup>3</sup>/h</b>	1,14	1,14	2,05	2,05	2,50
Flue gas temperature net value	<b>°C</b>	151	151	178	178	150

# BG 2000-S GAS BURNER FEATURES

## GAS CATEGORIES

		I2E(S)B	I2H3B/P	I2H3P	I2E3B/P	I2Er3P	I2L3B/P	I2L3P	I3P
<b>G20</b>		20 mbar	20 mbar	20 mbar	20 mbar	20 mbar			
<b>G25</b>		25 mbar				25 mbar	25 mbar	25 mbar	
<b>G30</b>			30 - 50 mbar		30 - 50 mbar		30 - 50 mbar		
<b>G31</b>			30 - 50 mbar	37 - 50 mbar	30 - 50 mbar	37 - 50 mbar	30 - 50 mbar	37 - 50 mbar	37 mbar
<b>BE</b>	Belgium	●							●
<b>CH</b>	Switzerland		●	●					
<b>CZ</b>	Czech republic		●	●					
<b>DE</b>	Germany				●				
<b>DK</b>	Denmark		●						
<b>EE</b>	Estonia		●						
<b>ES</b>	Spain			●					
<b>FR</b>	France			●		●		●	
<b>GB</b>	Great Britain			●					
<b>GR</b>	Greece		●	●					
<b>IE</b>	Ireland			●					
<b>IT</b>	Italy		●	●					
<b>LU</b>	Luxembourg				●				
<b>LT</b>	Lithuania		●						
<b>NL</b>	Netherlands						●	●	
<b>PL</b>	Poland				●				
<b>PT</b>	Portugal			●					
<b>SI</b>	Slovenia		●	●					
<b>SK</b>	Slovakia		●	●					
<b>SE</b>	Sweden		●						

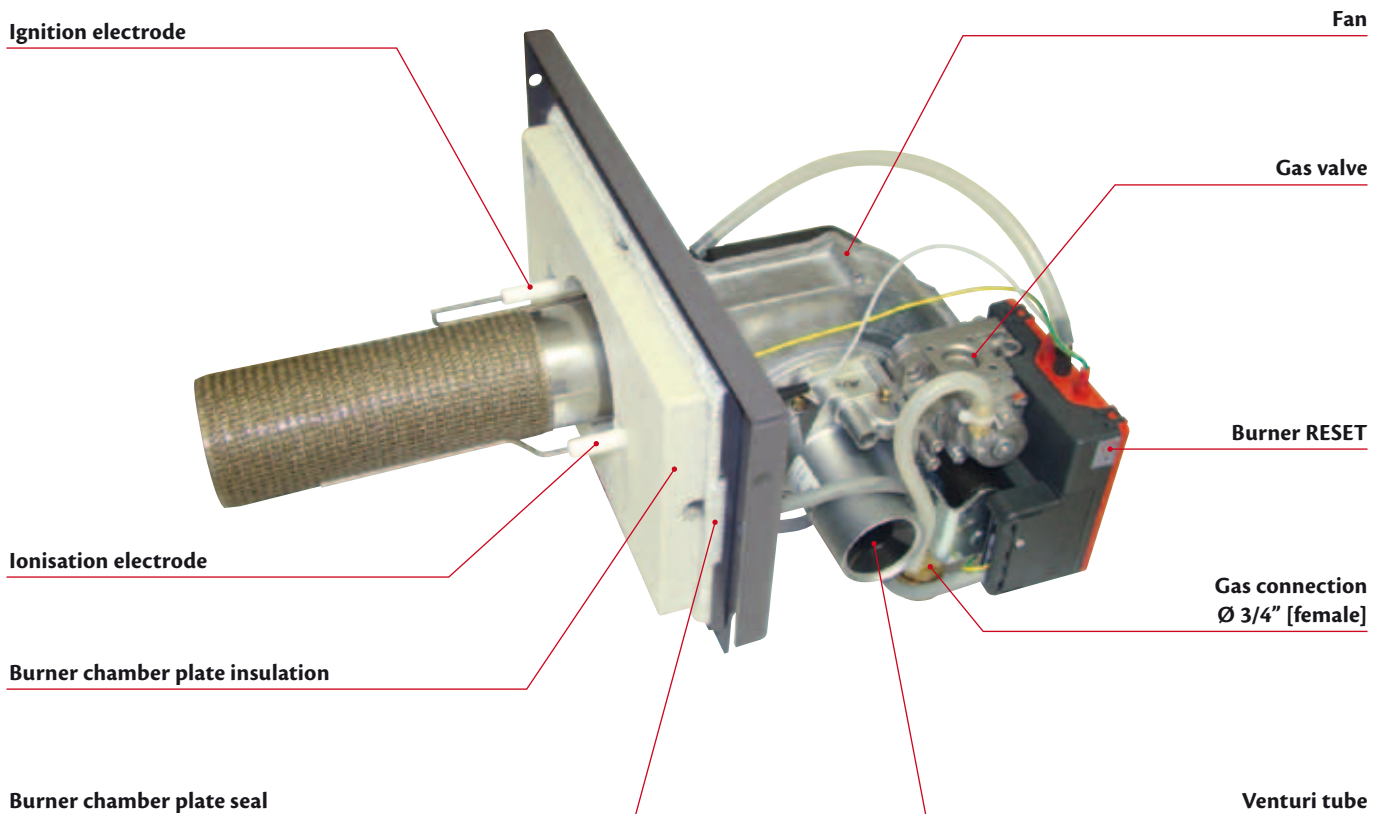
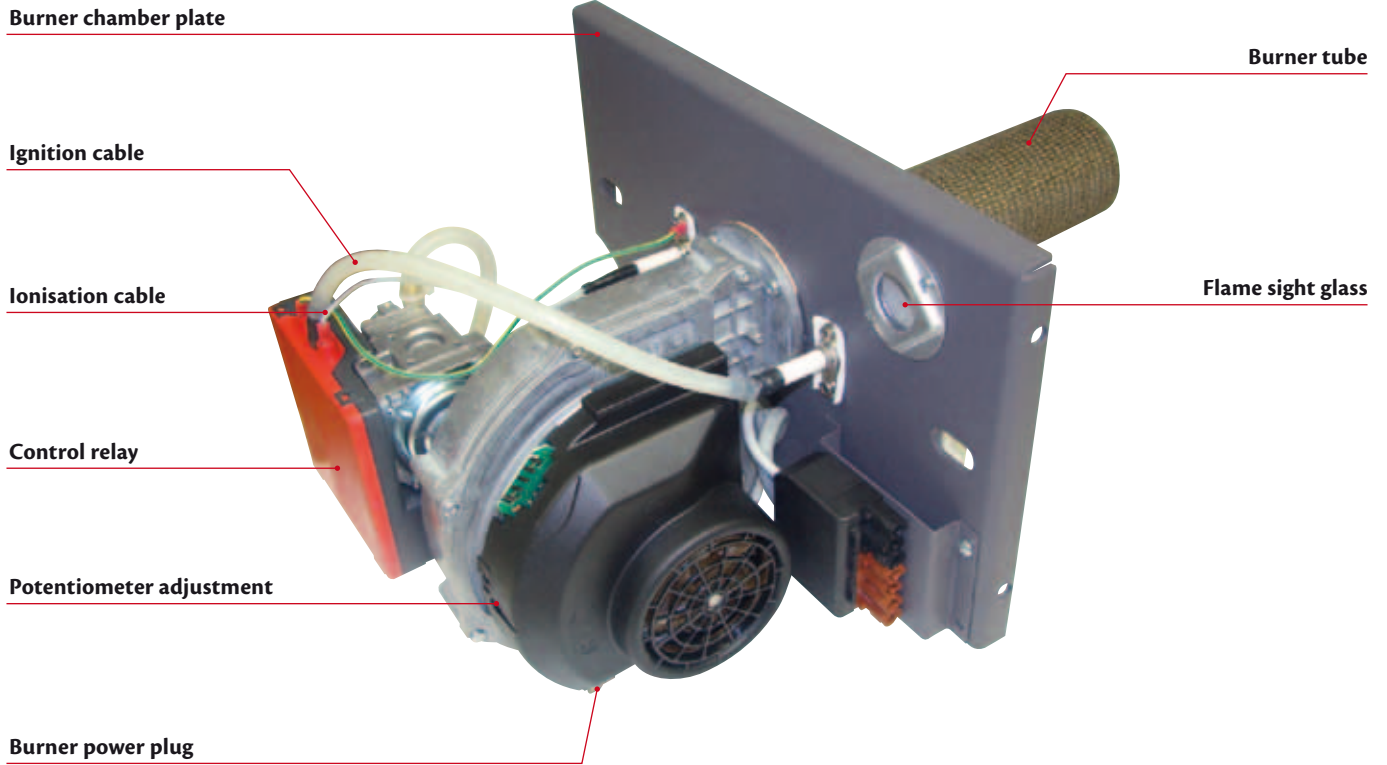

## FILLING OF DHW AND HEATING CIRCUITS



### IMPORTANT

It is essential that the DHW cylinder is filled and pressurised before filling the heating circuit.

1. Fill the DHW circuit and bring it up to pressure.
2. Fill the heating circuit taking care not to exceed the 2 bar pressure limit.
3. Vent the air from the top of the boiler.
4. After venting the air from the system, bring the pressure up to the static head plus 0.5 bar.

#### Head of the heating system:

- 10 m ⇒ heating circuit pressure = 1.5 bar
- 15 m ⇒ heating circuit pressure = 2 bar

## BOILER COMMISSIONING

1. Check the gas or oil supply connection and make sure there are no leaks.
2. Check the boiler power connection, the boiler room ventilation and ensure that there are no leaks in the combustion gas discharge pipes or the burner chamber plate.
3. Set the boiler thermostat or potentiometer to between 60°C and 90°C.
4. Set the Summer/Winter selector to the desired position.
5. Put the ON/OFF switch to the ON position.
6. Carry out the required venting, measurement and setting procedures.

## RECOMMENDATION

ACV advises that boilers should be serviced at least once a year. This service and any boiler inspections must be carried out by a qualified technician.

## BOILER MAINTENANCE

1. Switch off the power at the external isolator and shut off the gas or oil supply.
2. Set the on/off switch on the control panel to the OFF position.
3. Remove the top cover of the boiler (A).
4. Take off the top of the Flue reduction (B).
5. Remove the turbulators (C) from the flue pipes (D) for cleaning.
6. Remove the burner chamber plate [E].
7. Brush the flue pipes (D).
8. Clean the combustion chamber (F) and the burner.
9. Check the condition of the burner chamber plate insulation [H] and replace if necessary.

## BURNER MAINTENANCE

Refer to the burner's service and repair instructions.

## MAINTENANCE OF SAFETY DEVICES

- Check that all thermostats and safety devices are working properly: boiler thermostat, cut-off thermostat and manual reset safety thermostat.
- Check the safety valves of the heating and DHW circuits.

## DRAINING OF THE BOILER



Water flowing out of the drain cock is very hot and can cause severe burns. Keep people away from discharges of hot water.

## DRAINAGE OF THE HEATING CIRCUIT

1. Turn the ON/OFF switch on the control panel to the OFF position, isolate the boiler's external electrical supply and close the gas or oil supply valve.
2. Close the isolating valves (3) on the heating circuit.
3. Connect a flexible hose to the drain valve (8).
4. Open the drain valve (8) to empty the heating circuit.

## DRAINAGE OF THE DHW CIRCUIT

1. Turn the ON/OFF switch on the control panel to the OFF position, isolate the boiler's electrical supply and close the gas or oil supply valve.
2. Lower the heating circuit pressure until the gauge indicates zero pressure.
3. Close the valves (7 and 11).
4. Open the valves (9 and 10) (9 first then 10).
5. Let the hot water circuit empty into the drain.



The drain valve (9) must be at ground level to allow the cylinder to drain.



Water flowing out of the safety valve or the safety unit may be extremely hot and could cause severe burns.

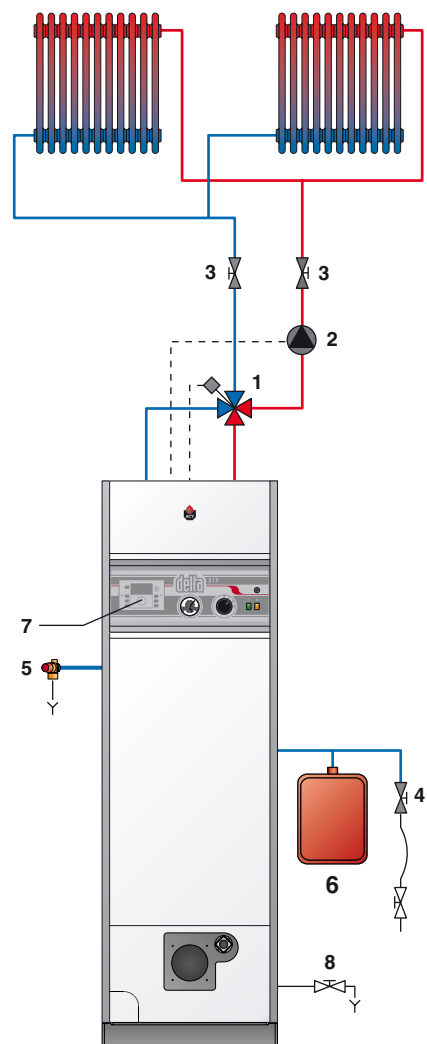
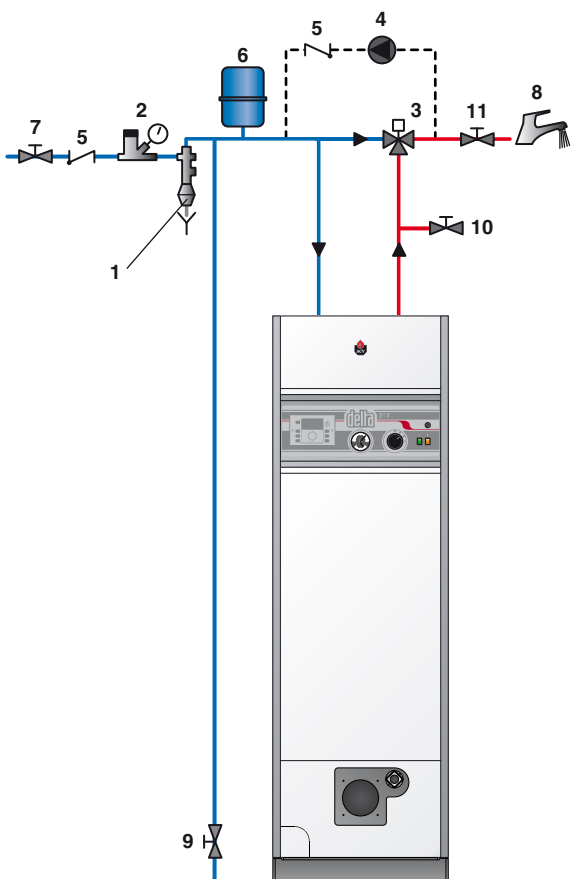
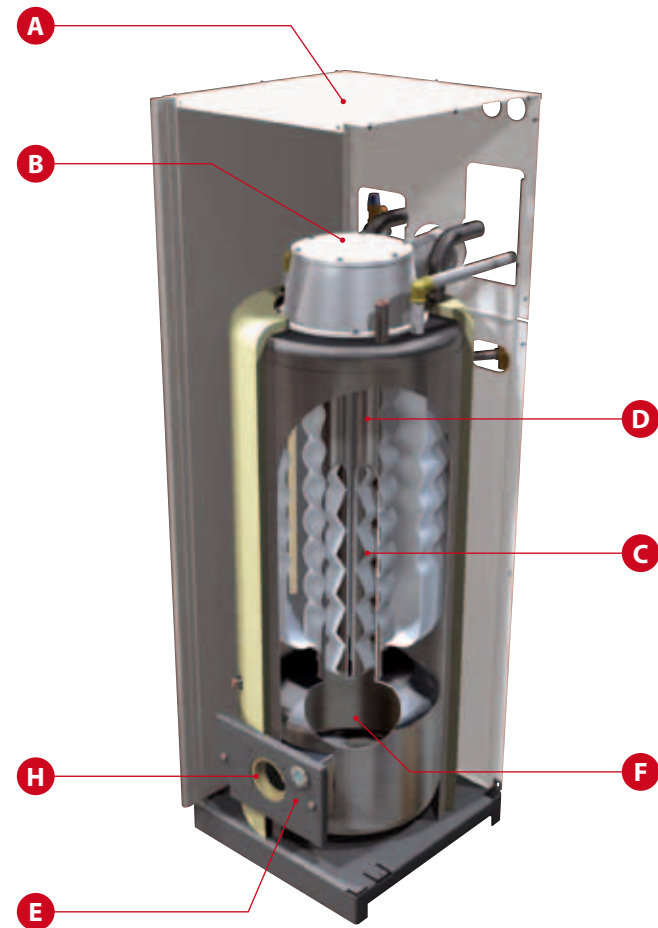

Handwriting practice area with horizontal dotted lines.



54322000

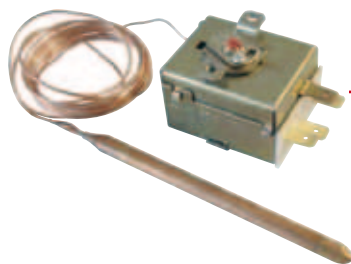

54764009



54441008

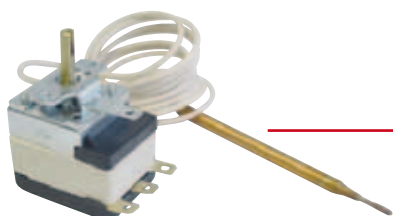

54442045



54764021



54766016



54766017



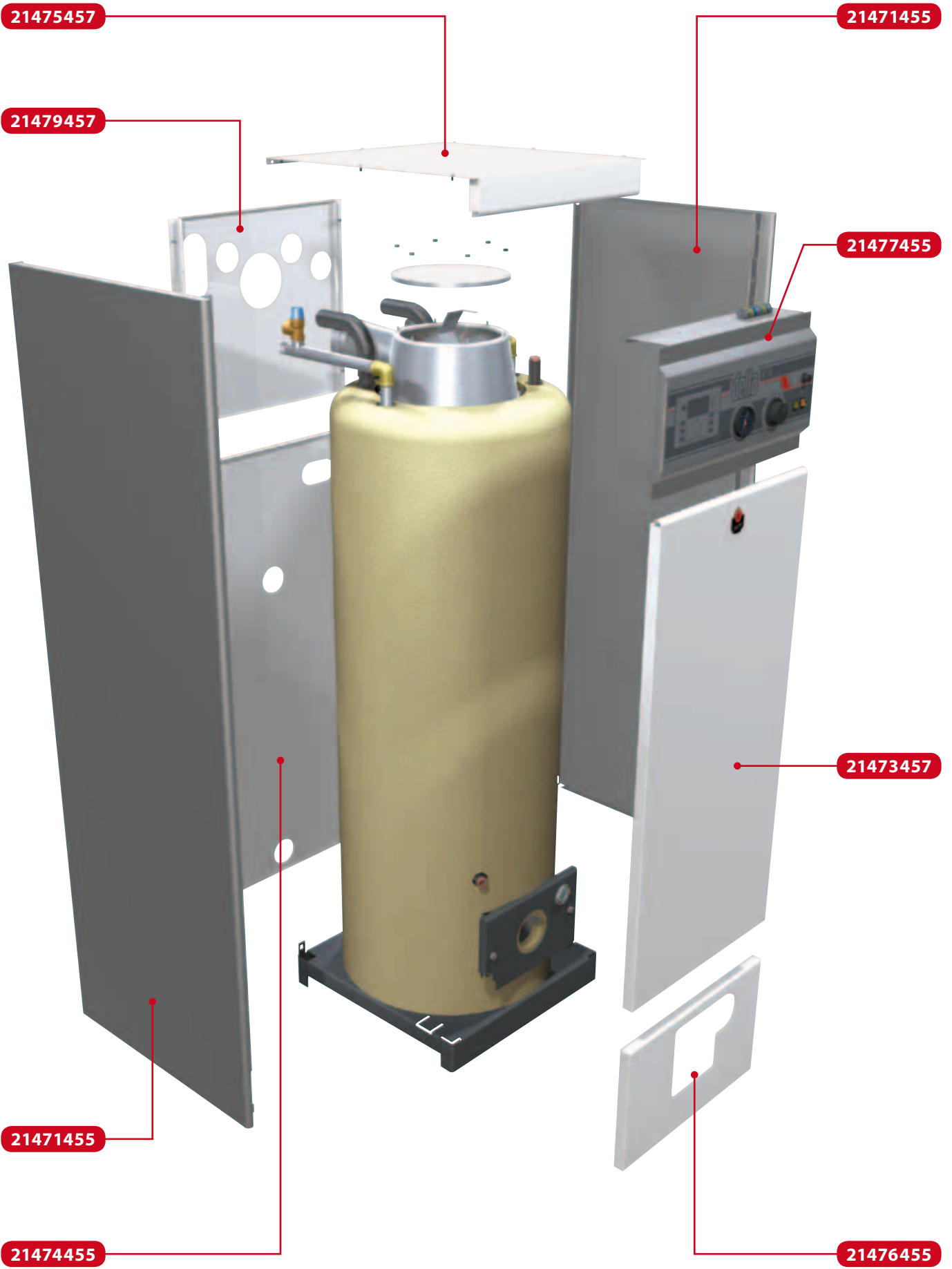

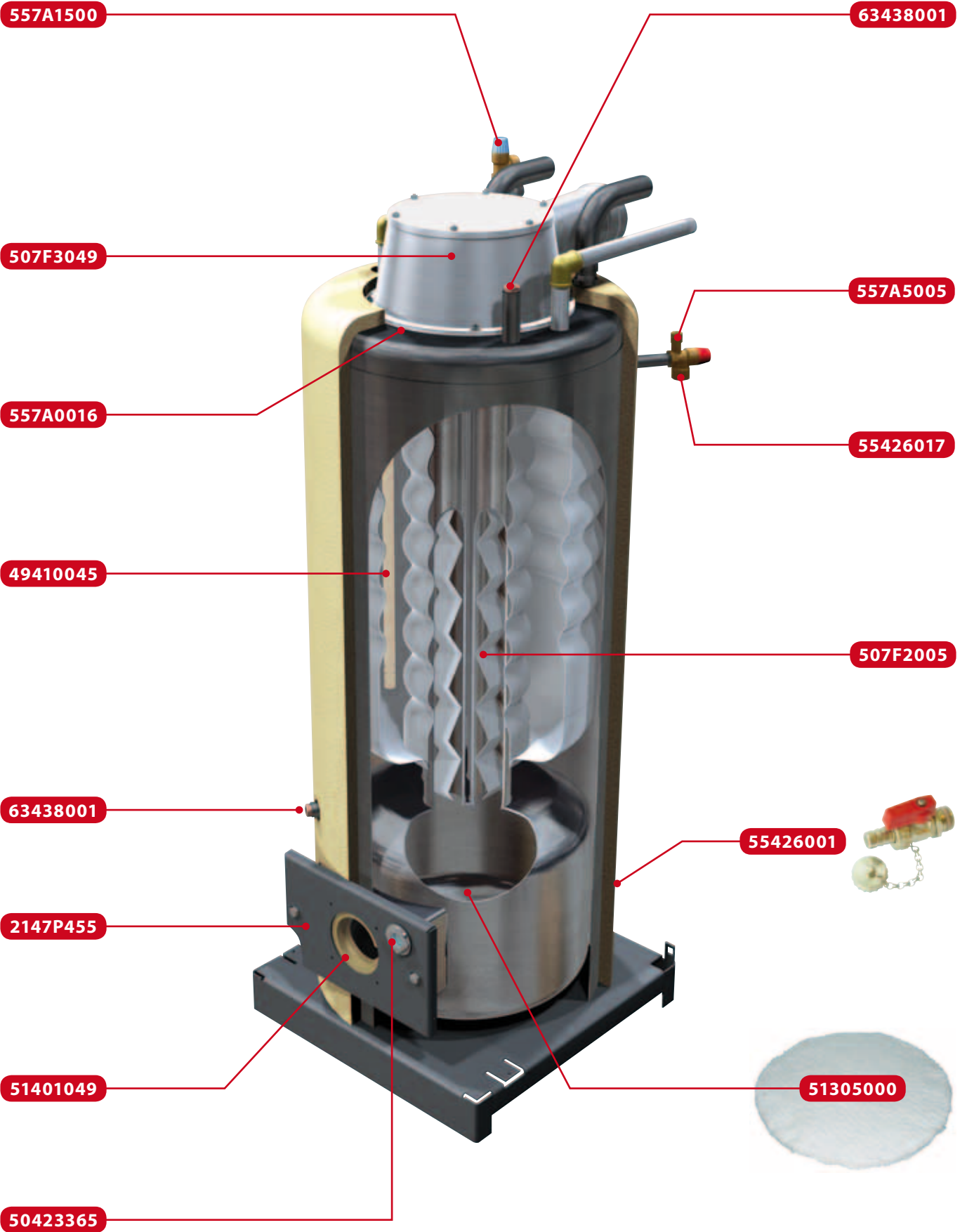

SPARE PARTS

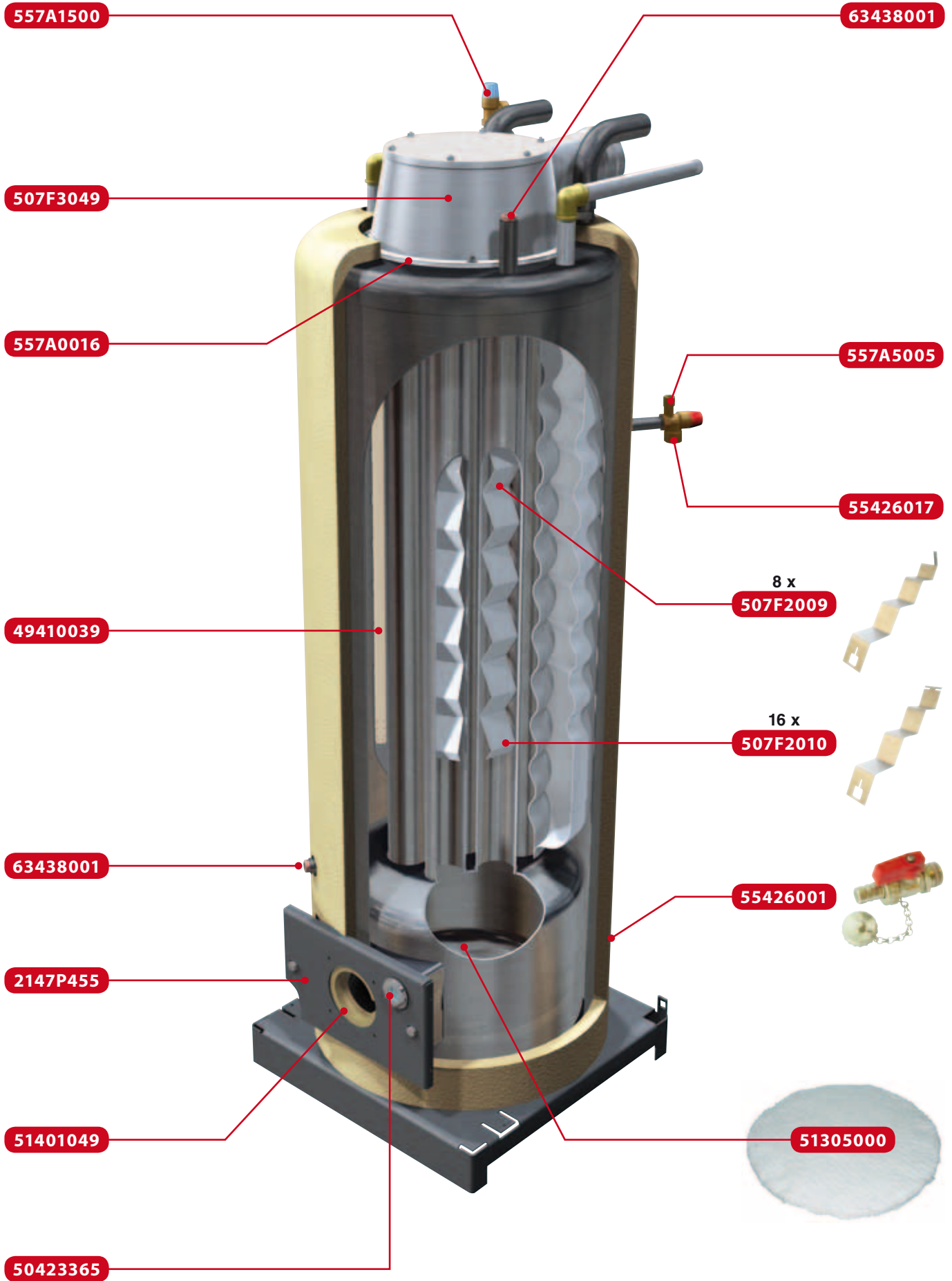

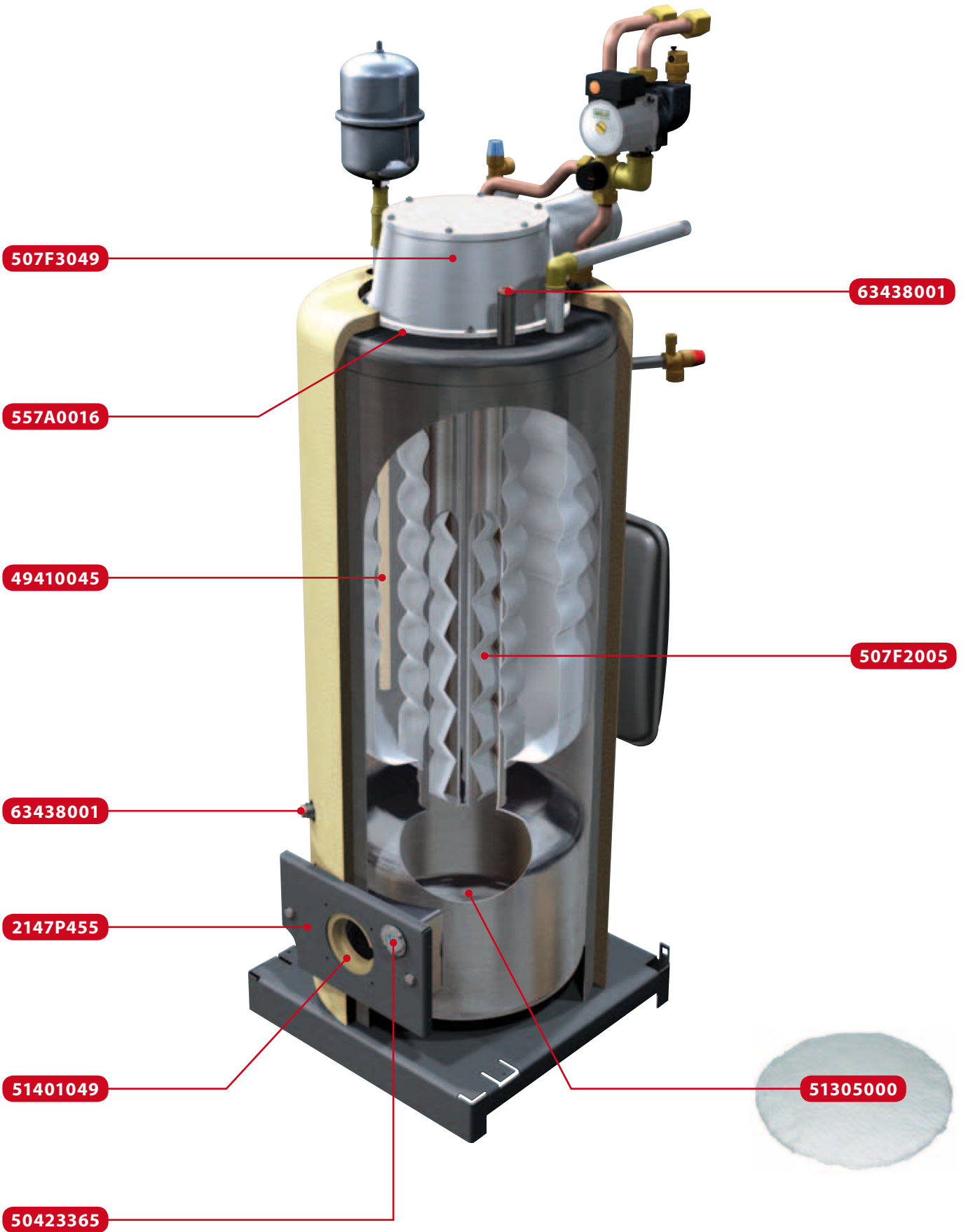

SPARE PARTS



